



# A Sensitivity Study of Commercial Aircraft Engine Response for Emergency Situations

*Jeffrey T. Csank*  
*Glenn Research Center, Cleveland, Ohio*

*Ryan D. May*  
*ASRC Aerospace, Inc., Cleveland, Ohio*

*Jonathan S. Litt and Ten-Huei Guo*  
*Glenn Research Center, Cleveland, Ohio*

## NASA STI Program . . . in Profile

Since its founding, NASA has been dedicated to the advancement of aeronautics and space science. The NASA Scientific and Technical Information (STI) program plays a key part in helping NASA maintain this important role.

The NASA STI Program operates under the auspices of the Agency Chief Information Officer. It collects, organizes, provides for archiving, and disseminates NASA's STI. The NASA STI program provides access to the NASA Aeronautics and Space Database and its public interface, the NASA Technical Reports Server, thus providing one of the largest collections of aeronautical and space science STI in the world. Results are published in both non-NASA channels and by NASA in the NASA STI Report Series, which includes the following report types:

- **TECHNICAL PUBLICATION.** Reports of completed research or a major significant phase of research that present the results of NASA programs and include extensive data or theoretical analysis. Includes compilations of significant scientific and technical data and information deemed to be of continuing reference value. NASA counterpart of peer-reviewed formal professional papers but has less stringent limitations on manuscript length and extent of graphic presentations.
- **TECHNICAL MEMORANDUM.** Scientific and technical findings that are preliminary or of specialized interest, e.g., quick release reports, working papers, and bibliographies that contain minimal annotation. Does not contain extensive analysis.
- **CONTRACTOR REPORT.** Scientific and technical findings by NASA-sponsored contractors and grantees.

- **CONFERENCE PUBLICATION.** Collected papers from scientific and technical conferences, symposia, seminars, or other meetings sponsored or cosponsored by NASA.
- **SPECIAL PUBLICATION.** Scientific, technical, or historical information from NASA programs, projects, and missions, often concerned with subjects having substantial public interest.
- **TECHNICAL TRANSLATION.** English-language translations of foreign scientific and technical material pertinent to NASA's mission.

Specialized services also include creating custom thesauri, building customized databases, organizing and publishing research results.

For more information about the NASA STI program, see the following:

- Access the NASA STI program home page at <http://www.sti.nasa.gov>
- E-mail your question via the Internet to [help@sti.nasa.gov](mailto:help@sti.nasa.gov)
- Fax your question to the NASA STI Help Desk at 443-757-5803
- Telephone the NASA STI Help Desk at 443-757-5802
- Write to:  
NASA Center for AeroSpace Information (CASI)  
7115 Standard Drive  
Hanover, MD 21076-1320

NASA/TM—2011-217004



# A Sensitivity Study of Commercial Aircraft Engine Response for Emergency Situations

*Jeffrey T. Csank*  
*Glenn Research Center, Cleveland, Ohio*

*Ryan D. May*  
*ASRC Aerospace, Inc., Cleveland, Ohio*

*Jonathan S. Litt and Ten-Huei Guo*  
*Glenn Research Center, Cleveland, Ohio*

National Aeronautics and  
Space Administration

Glenn Research Center  
Cleveland, Ohio 44135

---

April 2011

## Acknowledgments

The authors would like to thank Diana Drury of ASRC Aerospace Corporation, who handled the version control system through the iterations of this work, and to the NASA Aviation Safety Program's Integrated Resilient Aircraft Control project for funding this work.

Trade names and trademarks are used in this report for identification only. Their usage does not constitute an official endorsement, either expressed or implied, by the National Aeronautics and Space Administration.

*Level of Review:* This material has been technically reviewed by technical management.

Available from

NASA Center for Aerospace Information  
7115 Standard Drive  
Hanover, MD 21076-1320

National Technical Information Service  
5301 Shawnee Road  
Alexandria, VA 22312

Available electronically at <http://www.sti.nasa.gov>

# A Sensitivity Study of Commercial Aircraft Engine Response for Emergency Situations

Jeffrey T. Csank  
National Aeronautics and Space Administration  
Glenn Research Center  
Cleveland, Ohio 44135

Ryan D. May  
ASRC Aerospace, Inc.  
Cleveland, Ohio 44135

Jonathan S. Litt and Ten-Huei Guo  
National Aeronautics and Space Administration  
Glenn Research Center  
Cleveland, Ohio 44135

## Abstract

This paper contains the details of a sensitivity study in which the variation in a commercial aircraft engine's outputs is observed for perturbations in its operating condition inputs or control parameters. This study seeks to determine the extent to which various controller limits can be modified to improve engine performance, while capturing the increased risk that results from the changes. In an emergency, the engine may be required to produce additional thrust, respond faster, or both, to improve the survivability of the aircraft. The objective of this paper is to propose changes to the engine controller and determine the costs and benefits of the additional capabilities produced by the engine. This study indicates that the aircraft engine is capable of producing additional thrust, but at the cost of an increased risk of an engine failure due to higher turbine temperatures and rotor speeds. The engine can also respond more quickly to transient commands, but this action reduces the remaining stall margin to possibly dangerous levels. To improve transient response in landing scenarios, a control mode known as High Speed Idle is proposed that increases the responsiveness of the engine and conserves stall margin.

## Nomenclature

<i>Accel</i>	Acceleration Schedule
<i>alt</i>	Altitude (ft)
<i>BL</i>	Baseline Limits
<i>BW</i>	Bandwidth
<i>C-MAPSS40k</i>	Commercial Modular Aero-Propulsion System Simulation 40k
<i>dTamb</i>	Degrees Rankine from standard day temperature
<i>EGT</i>	Exhaust gas temperature (degrees Rankine)
<i>EP</i>	Extended Power
<i>EPR</i>	Engine Pressure Ratio
<i>FAA</i>	Federal Aviation Administration
<i>FastER</i>	Fast Engine Response
<i>Fnt</i>	Net Thrust (lbf)
<i>GM</i>	Gain Margin

HPC	High Pressure Compressor
HSI	High Speed Idle control mode
$K_i$	Integral Gain
$K_p$	Proportional Gain
LPC	Low Pressure Compressor
MAS	Modified Acceleration Schedule
$MAX$	Maximum function
$MIN$	Minimum function
MN	Mach number
MP	Maximum Power
$N_c$	Core Speed (revolutions per minute)
$N_{c\dot{}}$	Core Acceleration (revolutions per minute per second)
$N_f$	Fan Speed (revolutions per minute)
NL	No Limits
PI	Proportional plus Integral
PM	Phase Margin
$P_{s3}$	Compressor Discharge Static Pressure (psia)
$P_{xx}$	Total pressure at station $XX$ (psia)
$RU$	Ratio Unit ( $W_f/P_{s3}$ )
rpm	Revolutions per minute
$SLS$	Sea Level Static: environmental condition defined as an altitude of 0 ft and Mach number 0.0
$T_c$	Time constant (s)
$T_d$	Dead Time (s)
$T_{de}$	Time Delay (s)
$T_r$	Rise Time (s)
$T_s$	Settling Time (s)
$T_{xx}$	Temperature at station $XX$ (degrees Rankine)
VSV	Variable Stator Vane
$W_{bleed}$	Mass flow rate of air through the Variable Bleed Valve (lbm/s)
$W_{cust}$	Mass flow rate of air through the customer bleed valve (lbm/s)
$W_f$	Fuel flow rate (lbm/s)
$W_{xx}$	Mass flow rate through the engine at station $XX$ (lbm/s)

## I. Introduction

Research is on-going to investigate the use of an aircraft's engines to stabilize and control a distressed aircraft. For the engine to be used as a flight control effector, the engine may be required to perform beyond its current limitations: producing thrust greater than maximum rated power or responding faster to the pilot's throttle command. A sensitivity study is conducted using the Commercial Modular Aero-Propulsion System Simulation 40k (C-MAPSS40k) (Ref. 1) to determine the effect of extending or removing the engine controller's safety limits to enable the engine to operate beyond its nominal design range. Note that this study avoids major changes to the engine controller; all modifications will preserve the structure and form of the existing baseline controller (Ref. 2) and work within the constraints of the existing engine actuation.

It has been shown that in some emergencies the engines can serve as flight control actuators to improve the capabilities of the aircraft (Refs. 3 and 4). However, conservative engine controller design severely restricts maximum engine performance capability. The controller design is necessarily conservative because it is designed to provide safe operation throughout the flight envelope, regardless of the age of the engine. However, in emergency situations, this need to preserve safety margins can be traded for increased performance to improve the immediate survivability of the aircraft. This sensitivity study seeks to quantify how to make these trade-offs for the aircraft engine.

Previously, a sensitivity study was performed using the Commercial Modular Aero-Propulsion System Simulation (C-MAPSS), that considered both increasing the responsiveness of the engine and overspeed operation (Ref. 5). The engine modeled in C-MAPSS (Ref. 6) is a 90,000 lbf thrust class engine that is similar in design and architecture to the 40,000 lbf thrust class engine of C-MAPSS40k. The engine controller architecture is similar in that each imposes limits on various engine parameters such as shaft speeds and combustor pressure. The one difference of note is that the C-MAPSS controller actively limits the turbine temperature ( $T48$ ) while C-MAPSS40k does not contain such a limit. In commercial aviation, the management of engine temperature is typically left to the pilots; however reporting is required when temperatures exceed a maintenance threshold.

According to Reference 5, during overspeed operation, also referred to as overthrust, the C-MAPSS engine outputs, such as the rotor speeds, engine pressure ratio ( $EPR$ ), turbine temperature, static combustor pressure, and thrust, varied linearly with the throttle input. It was also noted that the engine limits, mainly rotor speeds, might need to be increased in order for C-MAPSS to reach the desired thrust level, but that increasing the rotor speed limits will have a negative impact on engine life.

While the overthrust case was briefly explored, the majority of Reference 5 focused on increasing the responsiveness of the engine to both small and large throttle transients. For small throttle transients of  $5^\circ$ , it was shown that simply increasing the controller bandwidth did not increase the performance of the engine due to the engine controller limits. However, doubling the controller bandwidth and disabling all of the controller limits allowed a significant reduction in the settling time. When reviewing the resulting data it was found that although all the limits were disabled, the nominal  $T48$  threshold was violated only for a brief period. These brief excursions in turbine temperature generally do not cause catastrophic failure; rather they deteriorate the engine at an accelerated rate. Thus, momentarily exceeding the nominal  $T48$  limit may be acceptable in an emergency scenario if the amount of risk to the engine is acceptable. The large throttle transients required the same type of changes made for the small throttle transients with an additional modification to the acceleration schedule.

This study was conducted using C-MAPSS40k to further the results obtained previously using C-MAPSS. C-MAPSS40k is a 40,000 lbf thrust class, two spool, physics-based, component level, high bypass turbofan engine simulation and closed loop controller modeled in the MATLAB/Simulink (The MathWorks, Inc.) environment (Ref. 1). The C-MAPSS40k open loop engine schematic is shown in Figure 1. Figure 1 shows the rotor speeds ( $N_f$  and  $N_c$ ), the Variable Stator Vanes (VSV), the pressures, temperatures, and flows at each of the engine's stations, as well as the flow through the Variable Bleed Valve ( $W_{bleed}$ ), turbine cooling bleeds ( $W_{28}$ ,  $W_{29}$ ,  $W_{31}$ ,  $W_{32}$ ), and customer bleed flow ( $W_{cust}$ ). C-MAPSS40k has the ability to control the engine thrust using either fan speed ( $N_f$ ) or Engine Pressure Ratio ( $EPR$ ), which is the exit pressure of the low pressure turbine ( $P_{50}$ ) divided by the pressure at the inlet ( $P_2$ ).

The C-MAPSS40k simulation package includes a representative generic commercial jet engine controller (Ref. 2). The aircraft engine controller can be separated into two functions: a power management controller, which is responsible for providing thrust and good transient performance, and a protection logic controller responsible for protecting the engine from exceeding any of its physical limits. Figure 2 shows a diagram of the C-MAPSS40k control system, and highlights the power management and protection logic controllers. As shown in Figure 2, the power management controller converts the throttle input to a setpoint ( $EPR$  or  $N_f$ ), calculates the error (difference between setpoint and feedback), and determines the fuel flow rate required to drive the engine to its setpoint using a PI controller with integrator wind-up protection. The protection logic controller protects the engine from physical damage

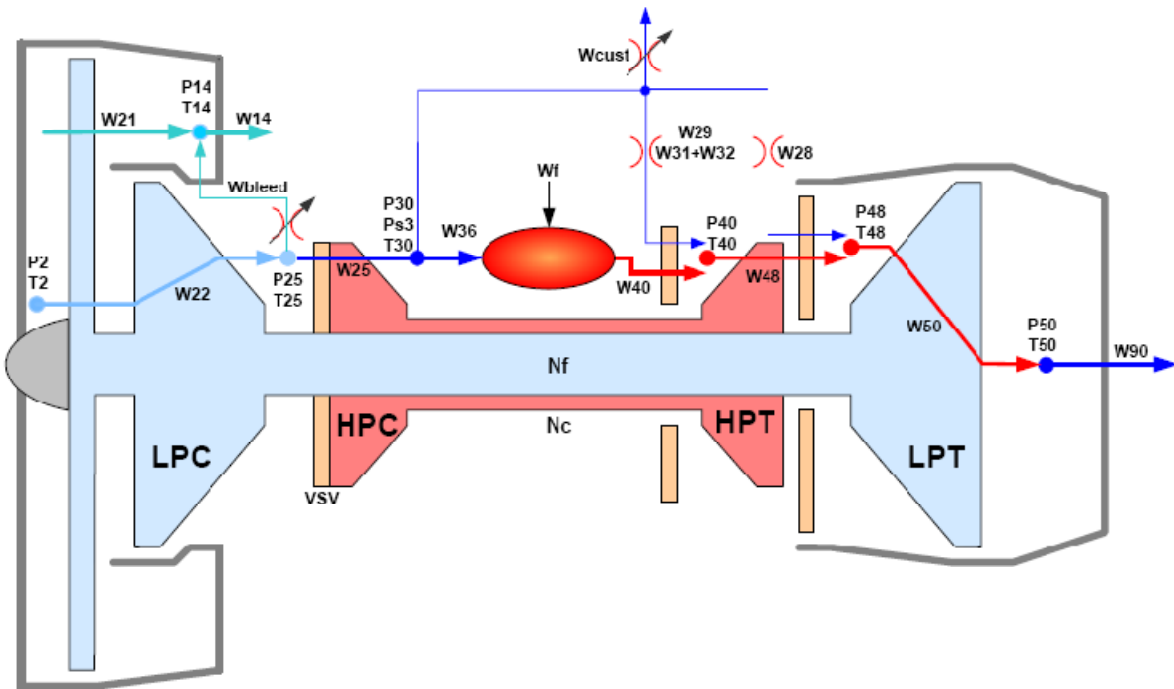

Figure 1.—C-MAPSS40k engine schematic.

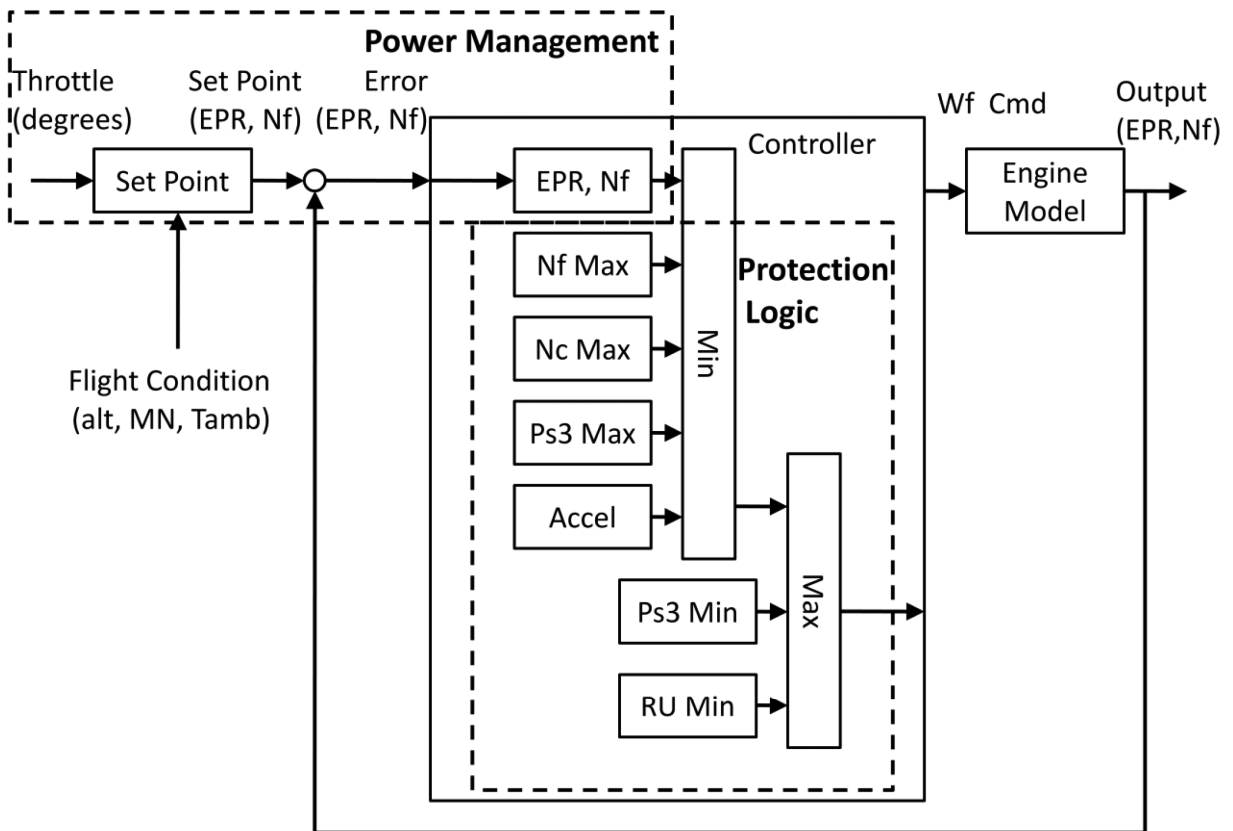

Figure 2.—C-MAPSS40k control system.



and maintains operation within acceptable bounds (e.g., it avoids compressor surge and stall and prevents combustor flameout) through the use of individual limit controllers, also referred to as limiters. The aircraft engine controller contains the following limiters: maximum fan speed ( $N_f \max$ ), maximum core speed ( $N_c \max$ ), maximum combustor static pressure ( $Ps3 \max$ ), maximum core shaft acceleration based on an acceleration schedule ( $Accel$ ), minimum combustor static pressure ( $Ps3 \min$ ), and minimum ratio unit ( $RU \min$ ) which is the fuel flow divided by the static combustor pressure. A *MIN-MAX* scheme is employed to select the fuel flow rate command from the limit controller closest to its limit, or the power management command in cases where no limits are in danger of being violated. This selection scheme also serves to provide a smooth transition between the protection logic and power management controllers.

This paper reports the results of the sensitivity study for C-MAPSS40k designed to determine the effect of operating the engine at conditions beyond its current limitations. This paper extends the type of overthrust analysis performed in Reference 5 to include the risk of engine failure due to producing additional thrust. In addition, this paper proposes a new control algorithm to increase the responsiveness of the aircraft engine when operating at low power. Section II contains a description of the scenarios considered in the sensitivity study. The details on the overthrust control mode, including the engine limits of interest and how much additional thrust can be obtained, are found in Section III. Section IV has details on increasing the responsiveness of the engine, known as fast engine response. The work is summarized in Section V.

## II. Sensitivity Study Scenarios

The purpose of this sensitivity study is to help determine how far the engine control limits can be extended during an emergency that imposes high risk to the aircraft. In such situations, it is posited that the increased risk taken by the engine actually decreases the aircraft risk, resulting in the minimal system risk, however such system analysis is beyond the scope of this paper. Specifically, there are a few scenarios in which engine control modification is being considered to provide additional performance. The two scenarios of interest for this study are: 1) a take-off incursion, where the distance for lift-off is suddenly decreased, and 2) a rudder/tail failure, where the effectiveness of the rudder control surface or vertical stabilizer is reduced. These two scenarios are depicted in Figure 3 taken from Reference 5.

In the take-off incursion scenario, the remaining runway distance an aircraft has to reach the take-off speed is suddenly decreased due to an object entering the runway; alternately, the pilot notices that the aircraft is attempting to take off on a runway that is too short. To correct this situation, it has been proposed to increase the thrust beyond the engine's maximum nominal thrust level (Ref. 5) which is depicted on the left side of Figure 3. The additional thrust the engine produces would accelerate the aircraft at a higher rate, enabling the aircraft to reach its takeoff speed in a shorter distance. The concern with producing the additional thrust is that it might require an increase in the turbine temperatures and rotor speeds beyond their current limits.

In the rudder/tail failure scenario, the aircraft has experienced either airframe or internal damage (loss of hydraulics), which reduces the effectiveness of the flight control surfaces. This is also illustrated in Figure 3. To help control the yaw angle of the aircraft in the case of rudder/tail failure, it has been proposed to increase the responsiveness of the engine (Ref. 5). Increasing the responsiveness of the engine corresponds to higher accelerations which may lead to a decrease in high pressure compressor (HPC) surge margin.

The engine response for each of the emergency scenarios, overthrust and fast engine response, will be investigated separately. Each of these scenarios will be simulated at different environmental conditions. Three different altitudes have been chosen at which to perform the study: one near sea level, John F. Kennedy International Airport (JFK) at an altitude of 13 ft; the international airport with the highest takeoff altitude in the continental United States, Denver International Airport (DEN), at 5,431 ft; and one in between, McCarran International Airport (LAS), at an altitude of 2,181 ft. Each test will be conducted for both a standard day and a hot day, as well as for a 50 hr engine and an end of life engine.

## Requirements via Scenario Analysis *Using Aircraft Flight Simulator*

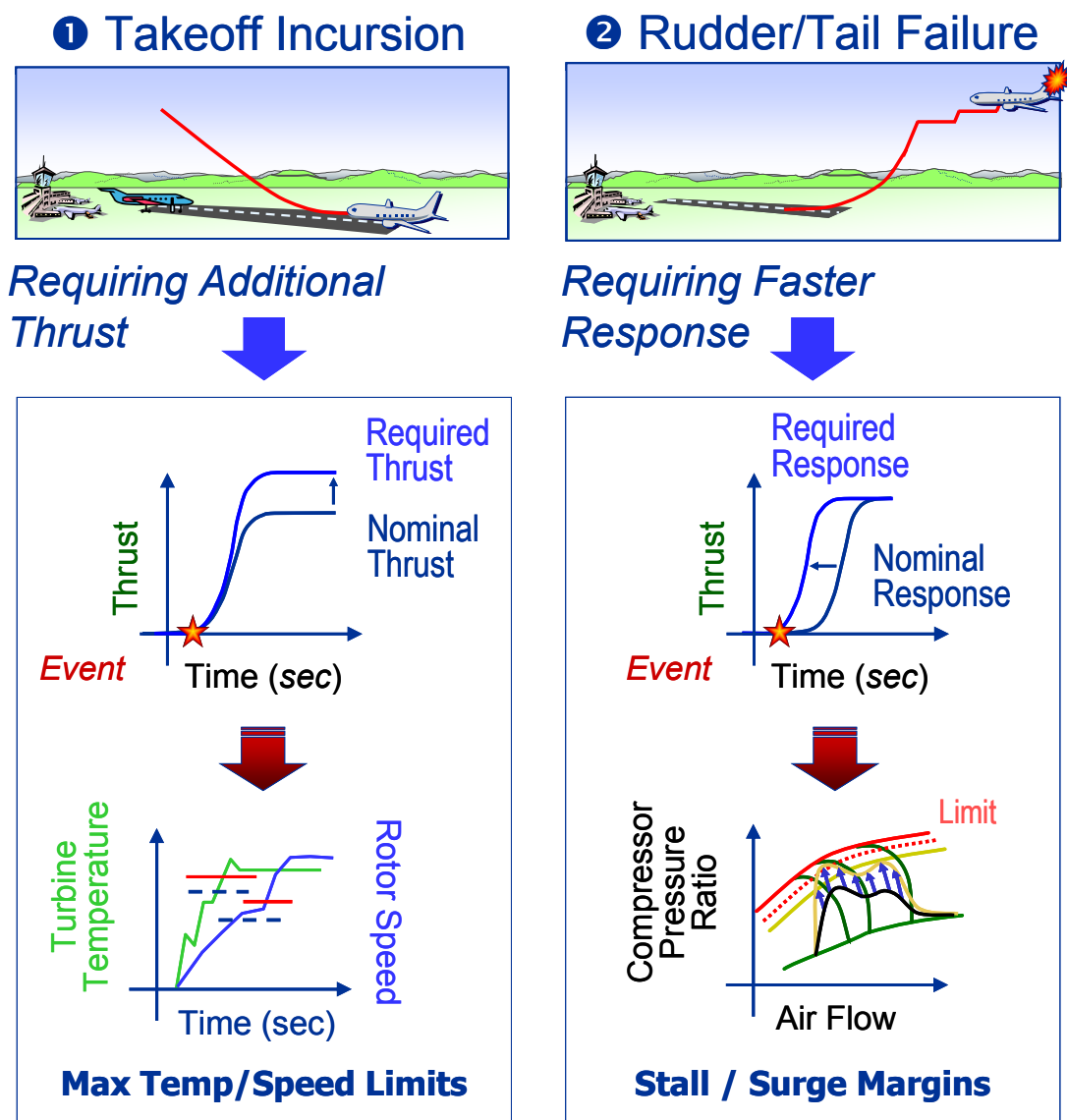

Figure 3.—The two emergency scenarios and corresponding engine responses. Figure from Reference 5.

### III. Overthrust (Runway Incursion)

For the overthrust situation, the engine is commanded to produce additional thrust, which correlates to a requirement for the engine to produce a higher *EPR* or fan speed. Therefore, the engine setpoints are extended to demand the additional power, but this also implies that the engine will be operating at speeds, temperatures, and pressures greater than the maximum ratings designed to ensure long engine life.

As discussed earlier, the C-MAPSS40k simulation has several protection logic controllers to ensure safe operation of the aircraft engine, shown in Figure 2. For the overthrust operation, the limits of interest are the maximum fan speed, maximum core speed, and maximum combustor pressure. The maximum fan and core speed limiters protect against disk burst or blade failure, while the maximum combustor pressure

protects from exceeding the combustor casing pressure limit (Ref. 2). For the sensitivity study, the maximum combustor pressure will not be extended as even momentary excursions outside of the combustor pressure range can cause sudden catastrophic damage. Another limit to monitor is the turbine temperature limit; when exceeded this leads to turbine blade erosion. In C-MAPSS40k there is no turbine temperature limit, rather an exhaust gas temperature ( $T50$ ) maintenance guideline exists, but there is no automatic limit protection; violating the guideline is at the pilot's discretion. The measurable exhaust gas temperature is typically used to approximate the temperature inside the turbines. The temperature maintenance guideline is usually violated in cases when the engine is over-fueled, (Ref. 7) which is required to produce additional thrust. In this study, the guideline will not be relaxed but the  $T50$  temperature will be monitored to determine the effect the various control limit modifications have on the exhaust gas temperature. The relevant C-MAPSS40k engine's limits and maintenance guidelines for the overthrust scenario are listed in Table 1.

TABLE 1.—C-MAPSS40k ENGINE'S NOMINAL LIMITS/MAINTENANCE GUIDELINES

Fan speed ( $N_f$ )	4,200 rpm
Core speed ( $N_c$ )	12,200 rpm
Combustor static pressure ( $P_{s3}$ )	433 psi
Exhaust gas temperature ( $T50$ )	1,500 °R

The first step in allowing the engine to produce additional thrust (by design), is to extend the control system's setpoints. The thrust profile indicates the amount of thrust desired as a function of the throttle position at a particular flight condition. From the thrust profile, the setpoint profile ( $EPR$  or fan speed) used to control the engine is created. The thrust profile, and corresponding setpoints, will be extended to provide additional power above maximum at each flight condition. This study will use C-MAPSS40k with  $EPR$  as the controlled variable. A 20 percent extension is arbitrarily chosen as a target. The C-MAPSS40k throttle range is from  $40^\circ$  to  $80^\circ$ , therefore the extended power range will be from a maximum throttle position of  $80^\circ$ , corresponding to 100 percent power, to  $90^\circ$  corresponding to 120 percent of maximum nominal power. Note that since the  $EPR$  profile is extended, the engine may not produce exactly the requested 120 percent maximum thrust.

There are two steps taken to determine which variables may limit the amount of additional thrust the engine can produce and the life cost of producing additional thrust. The first step is to maintain the nominal engine limits and command the additional 20 percent thrust. Ideally, this scenario would indicate the power the engine can produce without an increase in risk of failure. The second step is to remove the limits, except for the combustor static pressure limit, and command the additional 20 percent thrust. This will indicate by how much, if any, each limit must be increased to reach the desired thrust, and the amount of risk associated with this new operating point.

First, consider the engine response for a 50 hr engine at McCarran airport on a standard day (2,181 ft, 0.17 Mach, 0.0 °R from standard day temperature). The responses for maximum power (MP), extended power with the baseline limits (EP BL), and extended power with no limits (EP NL) are shown in Figure 4. At this flight condition, the 120 percent of maximum thrust can be reached without extending the current engine limits. In Figure 4, there is a slight difference between the EP BL and EP NL response from 100 percent max power to 120 percent max power. For the EP BL, since the limits remain unchanged, the limiters are free to become active and affect the thrust response, whereas for the EP NL, only the  $EPR$  setpoint controller can affect the thrust response; therefore there may be small differences in the transient to the new thrust level.

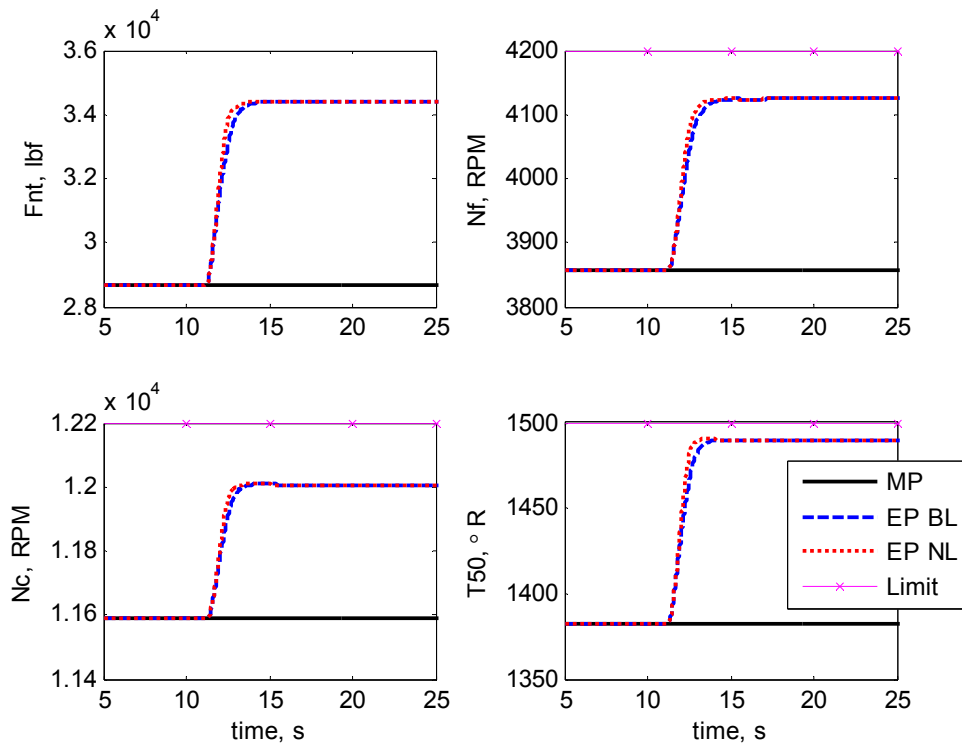

Figure 4.—Overthrust scenario comparing engine outputs at McCarran (2,181 ft, 0.17 Mach, +0 °R from standard day temperature, 50 hr engine).

Now consider the response for a 50 hr engine at Denver on a hot day (5,431 ft, 0.17 Mach, +48 °R from standard day temperature), which is shown in Figure 5. Figure 5 shows that with the baseline engine limits, the core speed limit restricts the amount of additional thrust the engine can produce. Additionally, even with the core speed limit in effect, the exhaust gas temperature maintenance guideline (1500 °R) is exceeded. In order for the engine to produce the desired 120 percent maximum power thrust, both the fan speed and core speed limits would have to be extended and a higher turbine temperature would have to be accepted.

The thrust, fan speed, core speed, and low pressure turbine temperature outputs for the extended power with baseline limits and extended power with the limits removed are shown in Table 2. Note that the two flight conditions printed in bold in Table 2 (13ft, 0.17 Mach, +0 °R from standard day temperature for both a 50 hr engine and end of life engine) are actually limited by the combustor pressure limit, which is not under consideration for modification. In Table 2, any individual variable above its limit for the flight condition is highlighted, and any variable that is limited is italicized. To reach 120 percent maximum power for all conditions, the fan speed limit would have to increase from 4,200 to 4,365 rpm (103.9 percent  $N_f max$ ), the core speed limit would have to increase from 12,200 to 12,530 rpm (102.7 percent  $N_c max$ ), and the  $T_{50}$  limit from 1,500 to 1,724 °R (114.9 percent  $T_{50} max$ ). Requesting additional thrust while maintaining the baseline engine limits results in a maximum exhaust gas temperature of 1,655 °R. Note that in the EP BL case the thrust may not be able to reach 120 percent due to the new temperature limiter. It is also worth restating the fact that the engine is controlled based on EPR, not thrust; thus, the thrust produced may exceed the desired 120 percent maximum thrust for the EP NL case.

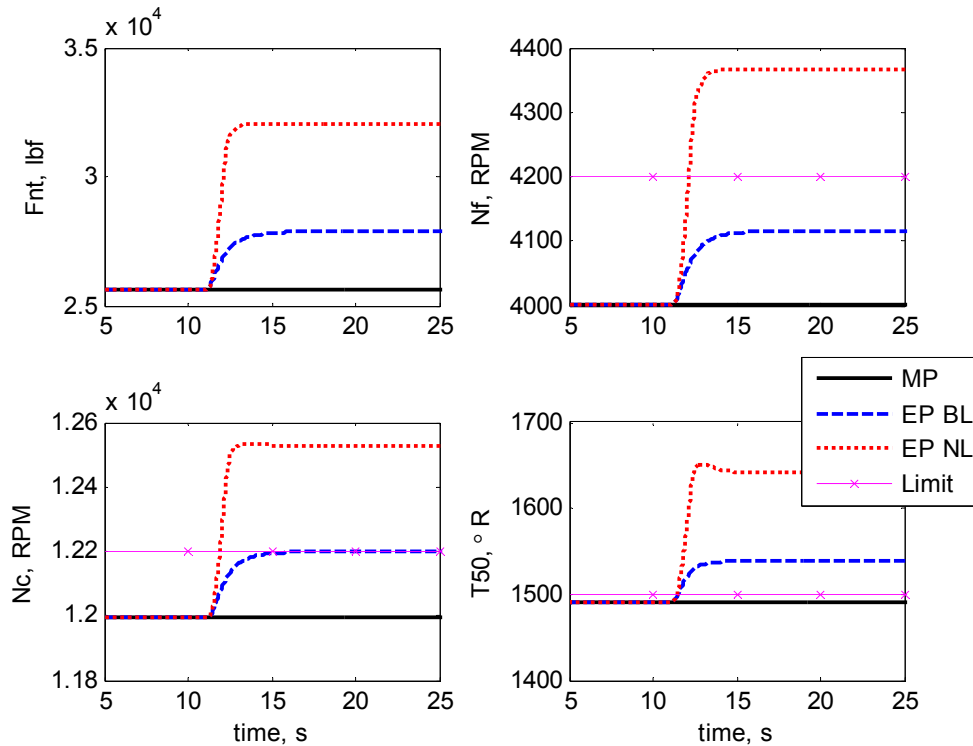

Figure 5.—Overthrust scenario showing engine outputs at Denver (5,431 ft, 0.17 Mach, +48 °R from standard day temperature, 50 hr engine).

TABLE 2.—CRITICAL ENGINE OUTPUTS FOR OVER THRUST OPERATION

Engine life	Flight condition, alt, MN, dTamb	Extended power base line limits				Extended power no limits			
		Thrust, percent	Nf, rpm	Nc, rpm	T50, °R	Thrust, percent	Nf, rpm	Nc, rpm	T50, °R
50 hr	<b>13 ft / 0.17 / 0 °R</b>	<b>119</b>	<b>4019</b>	<b>11911</b>	<b>1460</b>	<b>119</b>	<b>4019</b>	<b>11911</b>	<b>1460</b>
	2181 ft / 0.17 / 0 °R	120	4124	12004	1490	120	4124	12004	1490
	5431 ft / 0.17 / 0 °R	117	4200	12026	1504	121	4260	12104	1531
	13 ft / 0.17 / 48 °R	116	4073	12200	1548	121	4128	12298	1571
	2181 ft / 0.17 / 48 °R	112	4090	12200	1544	122	4212	12402	1595
	5431 ft / 0.17 / 48 °R	109	4116	12200	1540	125	4365	12530	1642
End of life	<b>13 ft / 0.17 / 0 °R</b>	<b>119</b>	<b>4014</b>	<b>11823</b>	<b>1540</b>	<b>119</b>	<b>4014</b>	<b>11823</b>	<b>1540</b>
	2181 ft / 0.17 / 0 °R	120	4113	11925	1565	120	4113	11925	1565
	5431 ft / 0.17 / 0 °R	118	4200	11961	1586	121	4246	12018	1607
	13 ft / 0.17 / 48 °R	120	4114	12200	1655	121	4119	12208	1657
	2181 ft / 0.17 / 48 °R	117	4137	12200	1652	122	4201	12305	1679
	5431 ft / 0.17 / 48 °R	113	4169	12200	1648	125	4351	12444	1724

To determine if these new operating conditions are acceptable, an example risk function is implemented similar to the one proposed in Reference 8. This risk function, which is a probabilistic model of engine life based on rotor speeds and turbine temperatures, will determine the probability of engine failure for a specified operating time at the given condition. Although a runway incursion may only require the additional thrust for a few minutes, the overthrust function may be utilized for long periods during flight in order to overcome drag due to aircraft damage. For this study, the risk function assumes that the engine will have to operate in the overthrust condition for 90 min. The 90 min time is a worst case estimate for a distressed plane flying over the continental United States to find an appropriate airport at which to land. Unfortunately the data necessary to determine true engine risk values are not readily available, thus the risk function implemented is approximate and will only allow trends to be discovered. Actual values for specific limits would necessitate detailed engine study and testing prior to implementation and control law development. The reader is referred to Reference 8 for more information regarding the risk function implementation and its limitations. For the purposes of this sensitivity study, we will proceed as if the risk model is accurate, however this approximation must be noted.

The thrust and risk values for maximum power, extended power with baseline limits, and extended power with no limits are shown in Table 3. In Table 3 any condition that produced a risk greater than 10 percent is highlighted. From Table 3, the extended power with baseline engine limits risk reaches up to 18.83 percent risk of failure for an end of life engine on a hot day, even though none of the active limits are exceeded. To prevent this excessive risk we can observe, from Table 2, that in this case *T50* is beyond its maintenance guideline by more than 150 °R. In order to allow us to take advantage of the additional thrust capability and ensure that the risk of operation does not exceed the risk level deemed acceptable (Ref. 9) a *T50* limiter can be added to the controller. The addition of the *T50* limiter will prevent the engine from reaching 120 percent full power in some cases, but does increase the safety by limiting the risk of engine failure to a level deemed acceptable by the pilot/flight controller.

Table 4 compares the thrust, *T50*, and risk for the extended power using the baseline limits but with the addition of a *T50* limiter. By setting the *T50* limit to 1,600 °R, the risk can be reduced from approximately 15 percent to less than 5 percent, as highlighted in Table 4. However, the reduction in risk also corresponds to a reduction in the thrust produced by approximately 2,000 to 3,000 lbf.

TABLE 3.—THRUST AND RISK FOR MAX POWER AND OVERTHRUST OPERATION

Engine life	Flight condition, alt, MN, dTamb	Max power		Extended power current limits		Extended power no limits	
		Thrust, percent	Risk, percent	Thrust, percent	Risk, percent	Thrust, percent	Risk, percent
50 hr	13 ft / 0.17 / 0 °R	100	0.001	119	0.568	119	0.568
	2181 ft / 0.17 / 0 °R	100	0.001	120	2.256	120	2.256
	5431 ft / 0.17 / 0 °R	100	0.002	117	3.862	121	8.061
	13 ft / 0.17 / 48 °R	100	0.017	116	3.993	121	9.087
	2181 ft / 0.17 / 48 °R	100	0.160	112	4.177	122	28.831
	5431 ft / 0.17 / 48 °R	100	1.348	109	4.503	125	99.956
End of life	13 ft / 0.17 / 0 °R	100	0.002	119	1.528	119	1.528
	2181 ft / 0.17 / 0 °R	100	0.003	120	3.913	120	3.913
	5431 ft / 0.17 / 0 °R	100	0.014	118	9.096	121	16.714
	13 ft / 0.17 / 48 °R	100	0.804	120	14.827	121	15.953
	2181 ft / 0.17 / 48 °R	100	1.603	117	16.262	122	45.324
	5431 ft / 0.17 / 48 °R	100	2.225	113	18.830	125	100.000

TABLE 4.—THRUST, EGT, AND RISK FOR OVERTHRUST OPERATION

Engine life	Flight condition, alt, MN, dTamb	Extended power current limit			Extended power current limit and T50 limited		
		Thrust, percent	T50 °R	Risk percent	Thrust percent	T50 °R	Risk percent
50 hr	13 ft / 0.17 / 0 °R	119	1460	0.568	119	1460	0.568
	2181 ft / 0.17 / 0 °R	120	1490	2.256	120	1490	2.256
	5431 ft / 0.17 / 0 °R	117	1504	3.862	117	1504	3.862
	13 ft / 0.17 / 48 °R	116	1548	3.993	116	1548	3.993
	2181 ft / 0.17 / 48 °R	112	1544	4.177	112	1544	4.177
	5431 ft / 0.17 / 48 °R	109	1540	4.503	109	1540	4.503
End of life	13 ft / 0.17 / 0 °R	119	1540	1.528	119	1540	1.528
	2181 ft / 0.17 / 0 °R	120	1565	3.913	120	1565	3.913
	5431 ft / 0.17 / 0 °R	118	1586	9.096	118	1586	9.096
	13 ft / 0.17 / 48 °R	120	1655	14.827	108	1600	2.654
	2181 ft / 0.17 / 48 °R	117	1652	16.262	106	1600	3.105
	5431 ft / 0.17 / 48 °R	113	1648	18.830	105	1600	4.086

TABLE 5.—RISK AS A FUNCTION OF DESIRED OPERATING TIME

Engine life	Flight condition, alt/MN/dTamb	Extended power no limits				
		15 min	30 min	45 min	60 min	90 min
50 Hr	13 ft / 0.17 / 0 °R	0.001	0.003	0.016	0.069	0.568
	2181 ft / 0.17 / 0 °R	0.001	0.008	0.062	0.274	2.256
	5431 ft / 0.17 / 0 °R	0.002	0.028	0.224	1.002	8.061
	13 ft / 0.17 / 48 °R	0.002	0.031	0.254	1.135	9.087
	2181 ft / 0.17 / 48 °R	0.004	0.109	0.900	3.991	28.831
	5431 ft / 0.17 / 48 °R	0.066	2.426	18.542	60.331	99.956
End of Life	13 ft / 0.17 / 0 °R	0.001	0.006	0.042	0.185	1.528
	2181 ft / 0.17 / 0 °R	0.001	0.014	0.107	0.478	3.913
	5431 ft / 0.17 / 0 °R	0.003	0.059	0.485	2.167	16.714
	13 ft / 0.17 / 48 °R	0.002	0.056	0.461	2.060	15.953
	2181 ft / 0.17 / 48 °R	0.006	0.193	1.591	6.974	45.324
	5431 ft / 0.17 / 48 °R	0.198	7.163	46.246	93.912	100.000

The desired operation time is an additional factor for the overthrust scenario. Table 5 contains the risk for the extended setpoint and no limit case for different desired operating times, to show the effect the operating time has on risk. As the desired operating time increases, the risk of failure also increases. For instance, at 5,431 ft, 0.17 Mach, on a hot day with a 50 hr engine, if 120 percent of maximum power is requested for 15 min, there is a 0.066 percent chance of a failure, however if the time is increased to 90 min there is a 99.956 percent chance of a failure using the risk function described earlier (Ref. 8). In addition, the ambient temperature also plays a big role; notice that at the same altitude and Mach number, the risk increases for the hotter day. The reason for this is that the engine has to work harder to produce the required thrust on hotter days, especially at higher altitudes.

In order for the engine to generate additional thrust at a given condition, the risk of engine failure will rise, mainly due to increased speeds and temperatures. The addition of the T50 limiter and an estimated operation time can ensure the engine does not exceed the risk level determined by the flight controller, minimizing the overall aircraft risk while maximizing the engine performance.

## IV. Fast Engine Response (FastER)

Fast Engine Response (FastER) is concerned with how quickly the engine can follow the throttle input. There are two different throttle transients of interest, small and large. In the rudder/tail failure case discussed earlier, the throttles are used collectively for longitudinal control and differentially for lateral/directional control. In an emergency situation, small throttle transients (generally less than 5° of throttle movement) have been shown to dampen out the phugoid mode, (Ref. 10) and stabilize the aircraft. The small throttle transient response is dominated by the tuning of the PI setpoint controller. To increase the performance of the closed loop system, the controller bandwidth is increased by increasing the integral term of the PI controller. The concern with increasing the bandwidth of the controller is the effect on the stability of the system, measured in terms of gain margin and phase margin. Increasing the bandwidth leads to a reduction in the gain margin and phase margin and could even degrade the performance if the margins are low enough. This is usually seen as an excessive amount of overshoot, which increases the settling time, and possibly results in oscillations about the setpoint.

The second type of throttle command of interest is a large change, from flight idle to full power. This type of throttle command would most likely be seen during an aborted approach or landing. The acceleration schedule is designed to protect the high pressure compressor from stalling during these large throttle transients. To increase the responsiveness of the engine for a large throttle transient, the acceleration schedule can be modified at the cost of stall margin reduction.

For either range of throttle transient, the performance is measured in terms of the following metrics and is shown in Figure 6:

- Time Constant (Tc): Time in seconds for the engine to reach 63.2 percent of the difference between the final thrust value and the initial thrust value, measured from when the engine response to a throttle step change begins.
- Delay Time (Tde): Time in seconds from when the throttle transient is initiated to 50 percent of the difference between the final thrust and initial thrust values.
- Dead Time (Td): Time in seconds from when the throttle transient is initiated to when the engine initially responds to the command.
- Settling Time (Ts): Time in seconds from when the throttle transient is initiated to the time when the output is within 2 percent of the difference between the final thrust and initial thrust values.
- Rise Time (Tr): Time in seconds it takes to transition from 10 to 90 percent of the difference between the final thrust and initial thrust values.

The following three sections, respectively will discuss the results of the sensitivity study for small transients, large transients, and finally for a new control mode known as High Speed Idle (HSI).

### A. Linear Controller (Small Throttle Commands)

The bandwidth of the linear setpoint controller is modified to increase the responsiveness of the engine for small throttle transients. An increase in the linear controller's bandwidth should lead to an increase in the closed loop performance (decrease settling time, rise time, etc.) but at the cost of gain margin and phase margin.

The performance and stability margins of the closed loop system for changes in the controller bandwidth are shown in Table 6. Table 6 compares the rise time, settling time, gain margin (GM) in decibels, and phase margin (PM) in degrees, for a 50 hr and an end of life engine at three approach conditions for the nominal PI controller and various controllers where the bandwidth is increased by modifying the integral term. While there is minimal change in the gain margin, modifications that cause the phase margin to decrease below the 45° design point are highlighted.



The results shown in Table 6 indicate that the lower the gain margin and phase margin are pushed, the better the performance. Increasing the integrator term by a factor of 1.6 results in phase margins below 40°, but does not have a significant improvement in the performance over increasing the integrator by a factor of 1.4, which results in a phase margin above 40°. Figure 7 shows an example of an engine with the integrator increased by a factor of 2.4, decreasing the phase margin to 24.82°. The response has a large overshoot, resulting in the same settling time as the nominal response; thus there is no advantage to increasing the integrator term to this extreme, especially considering the loss in stability margin.

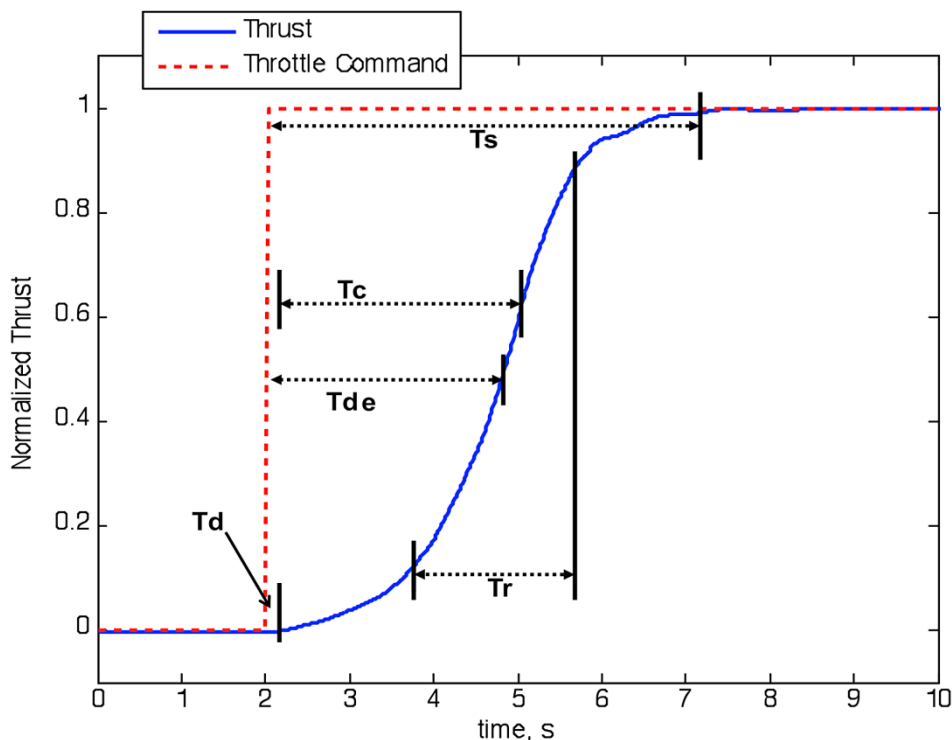

Figure 6.—Illustration of the performance metrics used for FastER.

TABLE 6.—CLOSED LOOP COMPARISON FOR CHANGES MADE TO THE PI CONTROLLER FOR A 5° THROTTLE TRANSIENT

Flight condition, alt/MN/dTamb	50 hr engine				End of life engine			
	Tr, s	Ts, s	GM dB	PM, °	Tr, s	Ts, s	GM, dB	PM, °
Nominal performance								
2013 ft / 0.26 / 48 °R	1.62	2.52	16.17	47.54	1.70	2.64	16.46	48.63
4181 ft / 0.26 / 48 °R	1.64	2.56	15.73	46.47	1.74	2.68	16.28	50.00
7431 ft / 0.26 / 48 °R	1.71	2.59	16.25	49.49	1.77	2.71	16.43	50.49
Integral term increased by factor of 1.2								
2013 ft / 0.26 / 48 °R	1.43	2.23	15.86	43.81	1.50	2.32	16.15	44.83
4181 ft / 0.26 / 48 °R	1.46	2.28	15.43	43.01	1.53	2.37	15.97	46.20
7431 ft / 0.26 / 48 °R	1.52	2.32	15.95	45.80	1.56	2.40	16.15	47.02
Integral term increased by factor of 1.4								
2013 ft / 0.26 / 48 °R	1.31	2.05	15.52	40.29	1.37	2.13	15.82	41.24
4181 ft / 0.26 / 48 °R	1.32	2.08	15.11	39.70	1.40	2.17	15.65	42.62
7431 ft / 0.26 / 48 °R	1.40	2.14	15.63	42.30	1.44	2.20	15.88	43.71
Integral term increased by factor of 1.6								
2013 ft / 0.26 / 48 °R	1.20	1.92	15.18	36.97	1.26	1.99	15.49	37.88
4181 ft / 0.26 / 48 °R	1.23	1.96	14.79	36.57	1.28	2.02	15.32	39.25
7431 ft / 0.26 / 48 °R	1.31	2.02	15.29	38.99	1.32	2.07	15.59	40.58

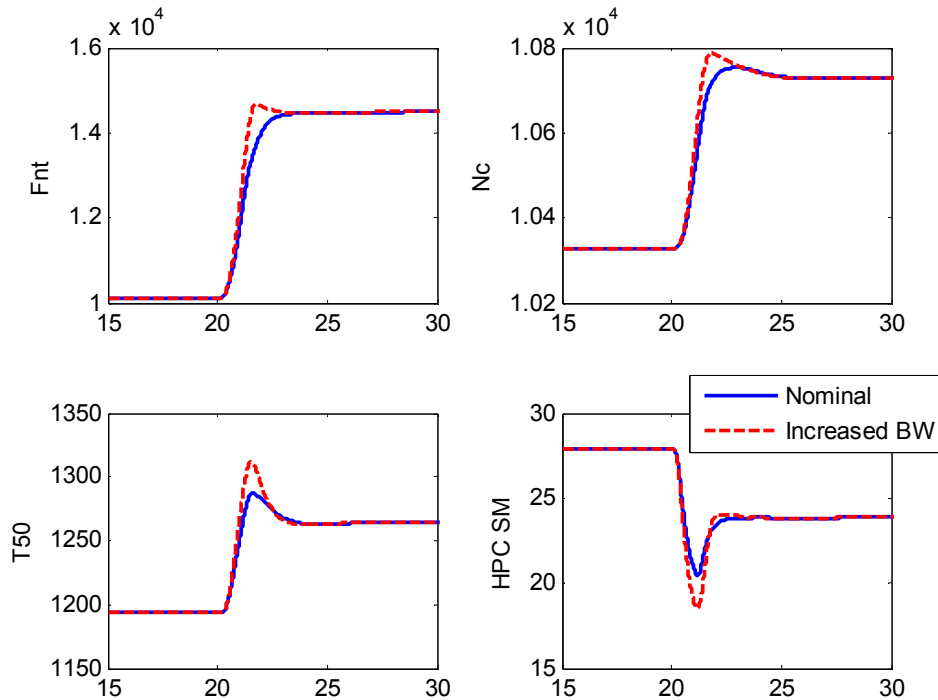

Figure 7.—Plot showing the effect of increasing the bandwidth to a value that decreases the phase margin below  $40^\circ$ . The integrator gain corresponding to the wider bandwidth system was increased by a factor of 2.4 over the baseline, which reduced the phase margin from  $48.24^\circ$  in the nominal case to  $24.82^\circ$ .

## B. Acceleration Schedule (Large Throttle Commands)

The acceleration schedule is designed to protect an end of life engine from stalling the high pressure compressor during a quick throttle transient from flight idle to full power. The acceleration schedule used in C-MAPSS40k was designed based on core acceleration versus core speed ( $Nc\dot{dot}$  versus  $Nc$ ). Figure 8 shows the baseline acceleration schedule for C-MAPSS40k along with a modified acceleration schedule (MAS). The modified acceleration schedule is the nominal acceleration schedule shifted by some value. In Figure 8, an example offset of 300 rpm per second is used, but any suitable value can be chosen. By modifying the acceleration schedule, the performance can be increased at the cost of reducing the stall margin.

In this study, the stall margin value is an indirect measurement of risk. One of the uncertainties that the acceleration schedule must account for is normal engine-to-engine variation. Since a below average engine must be able to accelerate safely, the schedule must be designed to accommodate a  $3\sigma$  variation in stall margin to essentially guarantee that no engine will stall. If the standard deviation install margin due to engine-to-engine variation is 1 percent, then in the worst case 99.86 percent of all engines will accelerate safely for a 3 percent designed minimum stall margin, as shown in Figure 9. Any adjustment of the acceleration schedule for faster response means that the below average engines are more likely to stall. This increased acceleration can be related to risk through a probability distribution function, where the risk of stalling is the portion of the distribution below 0 percent stall margin. The C-MAPSS40k simulation stalls when the surge margin reaches 0 percent. The percent of engines that stall increases as the designed stall margin value decreases. If there is overwhelming confidence that a specific engine is above average, then using a more aggressive acceleration schedule is acceptable.

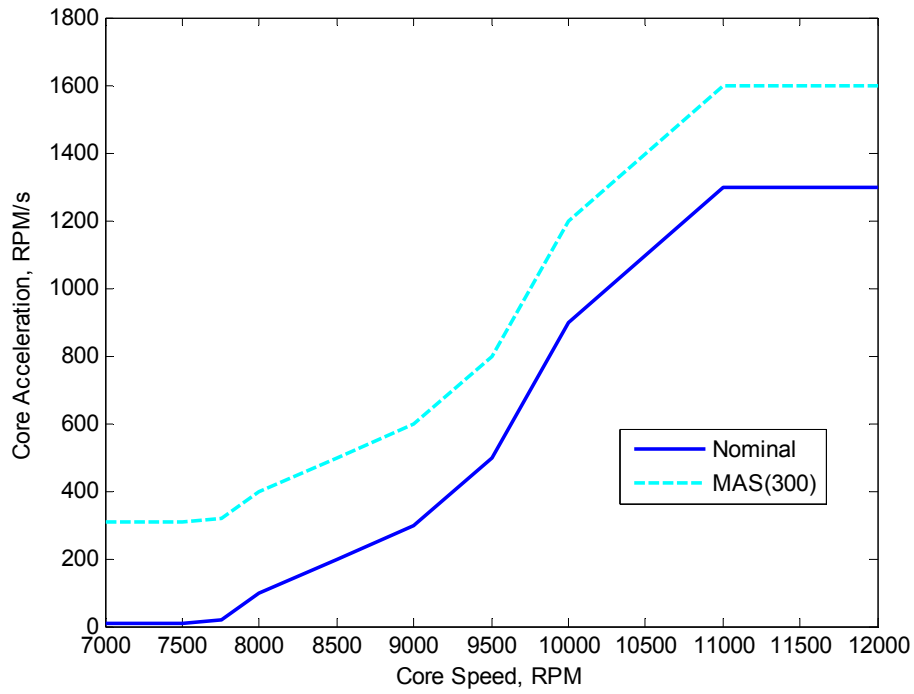

Figure 8.—Nominal and an example modified acceleration schedule value of 300 rpm/s (MAS(300)).

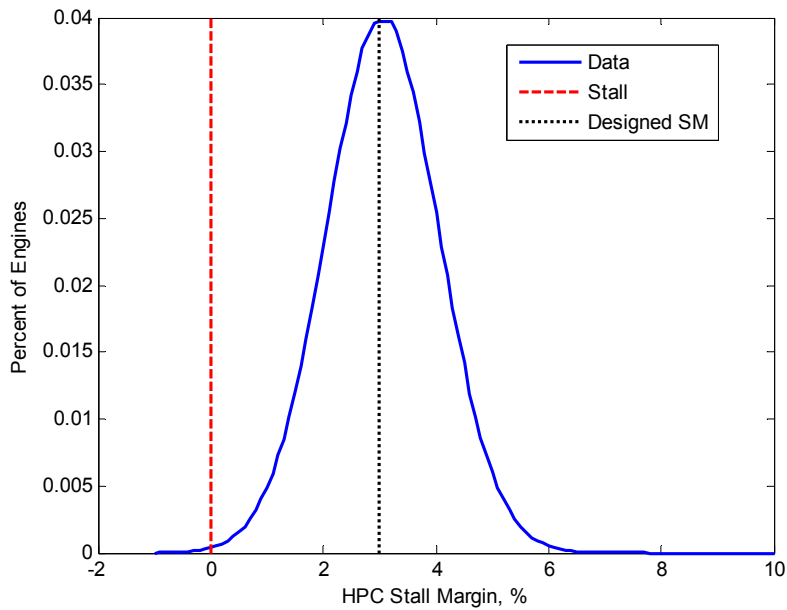

Figure 9.—Plot of the expected engine-to-engine variation in stall margin in an active fleet, indicating the need to retain a required minimum stall margin.

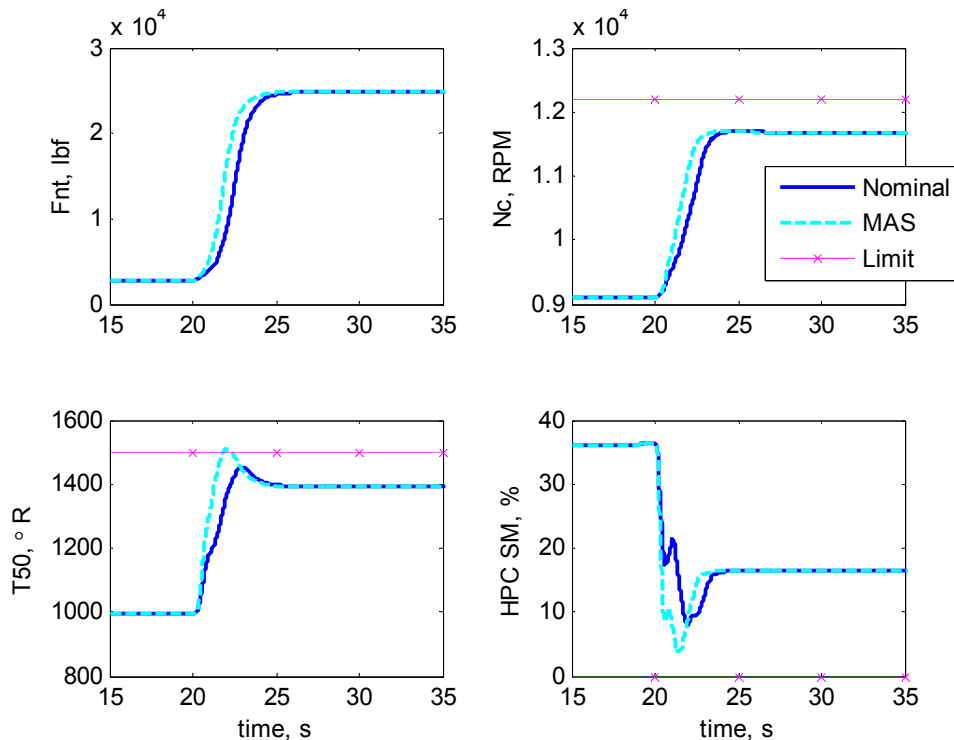

Figure 10.—Current response and response with the modified acceleration schedule (7,431 ft, 0.26 Mach, standard day temperature, 50 hr engine).

The engine response using the proposed modified acceleration schedule compared to the baseline response is shown in Figure 10. The quicker thrust response is associated with an increase in  $T50$ ,  $N_c$ , and a reduced HPC stall margin.

Table 7 compares the dead time, rise time, time constant, settling time, and minimum stall margin for the current acceleration schedule and the proposed MAS (300). Comparing the settling times and stall margins for the nominal and MAS response in Table 7, the performance of the engine increases (decreased settling time) with a reduction in the stall margin with the end of life engine, in some cases the stall margin is below zero meaning the engine would stall. Further investigation into Table 7 indicates that at some flight conditions the performance could still be increased by increasing the offset to the nominal schedule, while at other flight conditions the stall margin is less than 1.0 percent and a more conservative offset should be utilized. A lookup table for the offset value added to the nominal acceleration schedule can be created based on the flight condition, engine degradation level, and the acceptable minimum stall margin. This type of function would allow for more performance increase while still ensuring safe operation since the table would be designed to provide an average engine with the desired stall margin. For the case of an end of life engine where the minimum stall margin with the baseline acceleration schedule is less than 1.0 percent, no offset would be added to the engine since stalling the engine will likely lead to failure of the aircraft to land successfully.

One of the shortcomings with the modified acceleration schedule is that the increase in performance correlates with a reduction in stall margin. The nominal acceleration schedule shown in Figure 8 is designed such that the core acceleration is severely limited at lower core speeds, such as at flight idle conditions. If the core speed could be increased at flight idle conditions, then with no modification of the acceleration schedule the allowed core acceleration would be increased, allowing an increase in the performance of the engine without a reduction in the minimum stall margin. There would be no loss in the minimum stall margin since the performance is still bounded by the nominal acceleration schedule; the difference is the initial condition of the transient. This idea of increasing the idle power level is known as high speed idle, and is the subject of the next section.

TABLE 7.—C-MAPSS40K PERFORMANCE WITH MODIFIED ACCELERATION SCHEDULE FOR  
A THROTTLE TRANSIENT FROM FLIGHT IDLE TO FULL POWER

Flight condition, alt, MN, dTamb	Nominal performance					MAS (300)				
	Td, s	Tr, s	Tc, s	Ts, s	SM, percent	Td, s	Tr, s	Tc, s	Ts, s	SM, percent
50 hr engine										
2013 ft / 0.26 / 0 °R	0.385	2.010	2.175	4.150	11.926	0.325	1.740	1.960	3.505	7.705
4181 ft / 0.26 / 0 °R	0.385	2.085	2.280	4.405	10.480	0.325	1.800	2.020	3.700	6.272
7431 ft / 0.26 / 0 °R	0.370	2.235	2.400	4.690	8.147	0.325	1.950	2.065	3.940	3.851
2013 ft / 0.26 / 48 °R	0.520	3.105	2.985	6.205	9.117	0.400	2.925	2.635	5.365	3.787
4181 ft / 0.26 / 48 °R	0.520	3.240	3.000	6.460	7.577	0.385	3.060	2.635	5.605	2.313
7431 ft / 0.26 / 48 °R	0.505	3.285	3.000	6.655	5.329	0.385	3.060	2.605	5.770	0.300
End of life engine										
2013 ft / 0.26 / 0 °R	0.385	2.055	2.055	4.180	7.360	0.340	1.785	2.005	3.520	3.237
4181 ft / 0.26 / 0 °R	0.385	2.130	2.145	4.465	5.955	0.340	1.845	2.050	3.715	1.746
7431 ft / 0.26 / 0 °R	0.385	2.295	2.205	4.840	3.631	0.325	1.995	2.125	4.015	-0.61
2013 ft / 0.26 / 48 °R	0.520	2.985	2.850	6.220	4.394	0.400	2.775	2.695	5.290	0.679
4181 ft / 0.26 / 48 °R	0.595	3.135	3.165	6.805	2.817	0.415	2.895	2.860	5.665	-1.20
7431 ft / 0.26 / 48 °R	0.550	3.150	3.225	6.955	0.591	0.400	2.910	2.845	5.770	-3.61

### C. High Speed Idle

As proposed in the previous section, an increase in the idle core speed could lead to faster transients for large throttle movements without a reduction in the nominal minimum stall margin, due to the higher starting point. The challenge associated with this approach is that increasing the core speed, or flight idle condition, results in a higher fan speed that corresponds to more thrust being produced. During approach, when the throttle is at flight idle, producing additional thrust will likely increase the speed of the aircraft as well as the distance required to land. Note that the aircraft’s control surfaces may be able to spoil some additional thrust, but not a significant amount.

One way to increase the core speed and not produce a large amount of additional thrust is to change the variable stator vane (VSV) input. The VSV is at the inlet of the high pressure compressor shown in Figure 1 and is nominally scheduled as a function of the corrected core speed. Using off-nominal VSV commands results in a change in the high pressure compressor operating point. By moving to a less efficient point on the map we can force the power management controller to increase the fuel flow rate, and therefore the core speed, in order to maintain the desired *EPR* or *Nf* setpoint. Since most of the thrust is produced by the fan, this adjustment does not produce a large increase in thrust. For an altitude of 4,181 ft, 0.26 Mach, standard day temperature, a 50 hr engine, and a fixed idle fuel flow rate (open loop), the baseline engine outputs are compared to the outputs with a 5° decrease in the VSV, shown in Figure 11. Figure 11 indicates that modifying the VSV causes a decrease in the thrust, fan speed, combustor static pressure, and low pressure turbine exit pressure (*P50*), and an increase in both the core speed and exhaust gas temperature.

For closed loop operation using *EPR* as the setpoint, modifying the VSV angle decreases *P50*, decreasing *EPR*, which causes an error between the desired and actual *EPR*. The fuel flow rate increases to drive the *EPR* to the setpoint and the thrust increases to approximately the same thrust level as with nominal control. With the modified VSV schedule, the core speed is higher and therefore the transition time from flight idle to full power will be shorter due to the higher idle core speed.

For some flight idle conditions, the ratio unit (*RU*) limiter will be active instead of the *EPR* controller. The *RU* value multiplied by the current combustor static pressure is the fuel flow rate determined by the *RU* control limiter. Modifying the VSV decreases the combustor static pressure, which will decrease the fuel flow rate. Therefore, the *RU* min value has to be increased to offset the pressure loss due to modifying the variable stator vane angle and to create the high speed flight idle condition when the *RU* limiter is active.

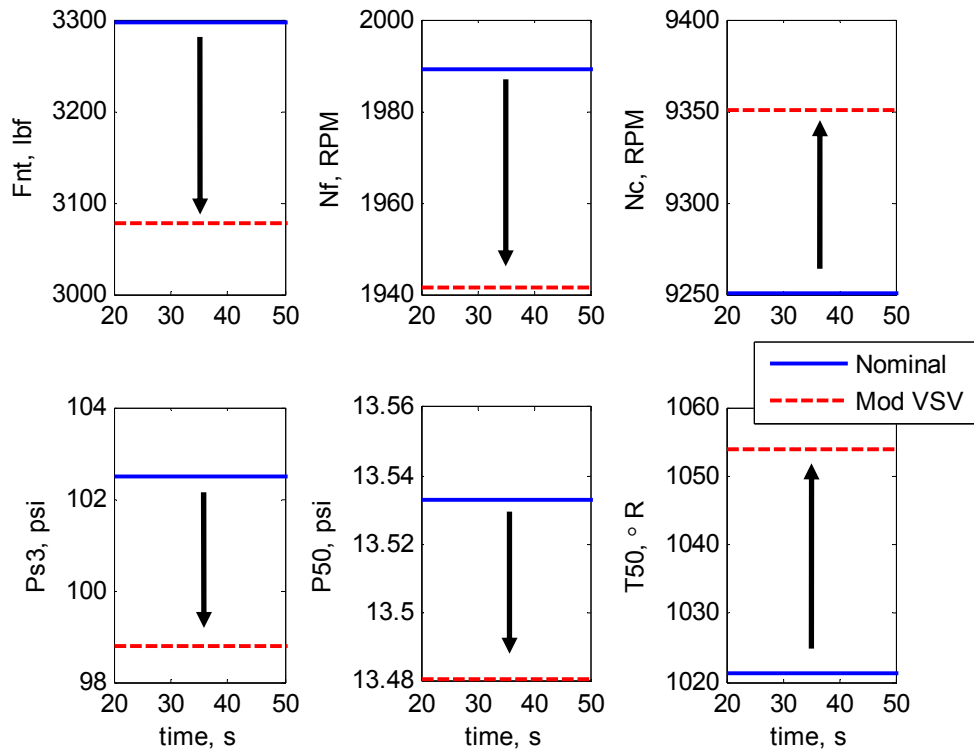

Figure 11.—Open loop engine outputs comparing the nominal engine outputs and modified VSV (Mod VSV) for a constant fuel flow.

In addition to the VSV and *RU* min modifications, the modified acceleration schedule is included in the high speed idle control mode to provide the best results. Figure 12 compares the response for the nominal, MAS with a function that determines the offset values based on the operating condition, and high speed idle controllers at 2,013 ft, 0.26 Mach, 48 °R above standard day temperature, for a 50 hr engine. Table 8 contains the dead time, rise time, delay time, time constant, setting time, and minimum stall margin for three flight conditions for the nominal response, MAS, and high speed idle.

Table 8 indicates that high speed idle produces a better response than MAS but with a slightly lower stall margin remaining. The stall margin for high speed idle could be increased by reducing the modification made to the MAS acceleration schedule.

Another way to increase the performance of the high speed idle control mode is to further decrease the efficiency of the engine by bleeding some of the core flow during idle conditions. Increasing the customer bleed flow should increase the core speed further, resulting in a higher idle condition. The customer bleed valve is shown in Figure 1, and reduces the flow through the core (*W36*). The *Nf*, *Nc*, net thrust, *Ps3*, *P50*, and *T50* engine outputs with a constant fuel flow (open loop) for both the nominal engine configuration and with the bleed valve active are shown in Figure 13. Figure 13 indicates that the core speed increases while the net thrust decreases with the customer bleed valve active.

The results of the high speed idle with MAS and bleed valve are compared against both the nominal engine response and high speed idle with MAS for a large throttle transient in Figure 14. Figure 14 shows the increase in core speed with HSI-Bleed and approximately the same thrust at idle. The high speed idle with bleed valve clearly has the fastest thrust response at the flight condition shown in Figure 14.

Table 9 contains the performance metrics and stall margins for the nominal, FastER, high speed idle, and high speed idle with customer bleed valve engine responses. Table 9 indicates that in terms of settling time and stall margin, high speed idle with customer bleed valve provides the best response.

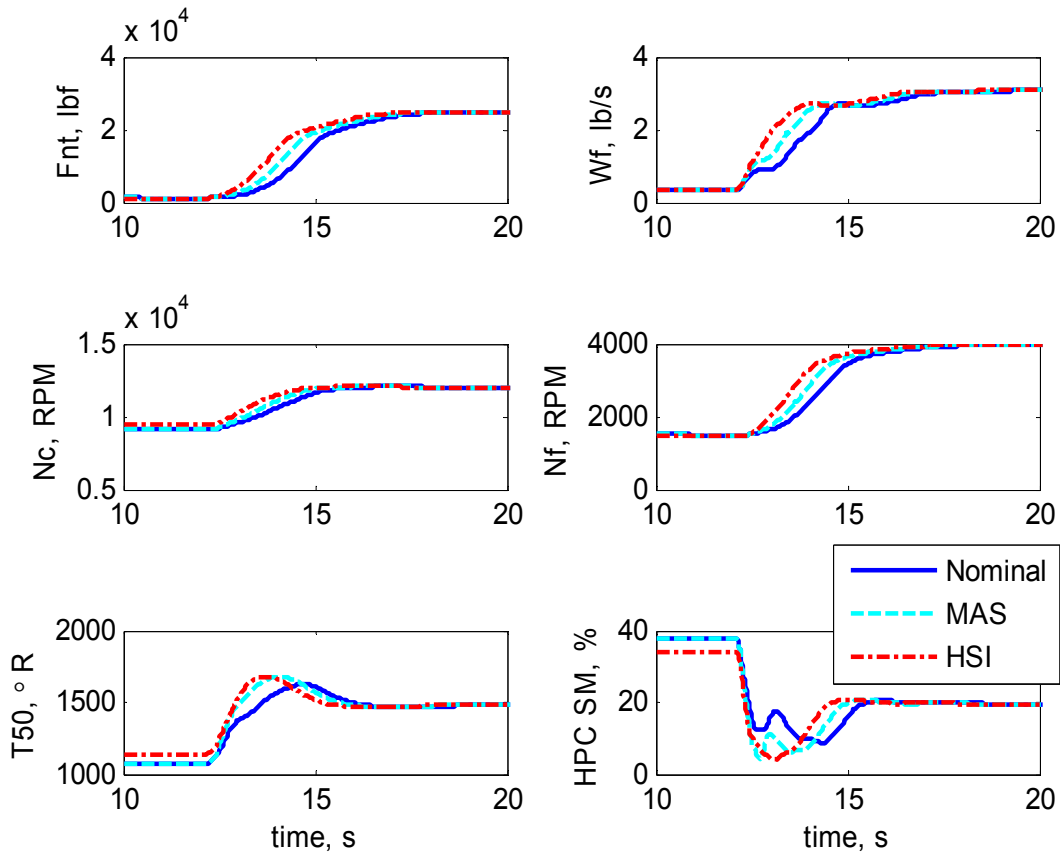

Figure 12.—Comparison of Nominal, Modified Acceleration Schedule (MAS), and High Speed Idle (HSI) responses for flight idle to full power throttle transient (2,013 ft, 0.26 Mach, 48° above standard day temperature, 50 hr engine).

TABLE 8.—COMPARISON OF NOMINAL, MODIFIED ACCELERATION SCHEDULE, AND HIGH SPEED IDLE DATA FOR A THROTTLE TRANSIENT FROM FLIGHT IDLE TO FULL POWER

Operating condition, alt/MN/dTamb	Td, s	Tr, s	Tde, s	Tc, s	Ts, s	SM, percent
Nominal						
2013 ft / 0.26 / 48 °R	0.520	3.105	3.205	2.985	6.205	9.117
4181 ft / 0.26 / 48 °R	0.520	3.240	3.220	3.000	6.460	7.577
7431 ft / 0.26 / 48 °R	0.505	3.285	3.220	3.000	6.655	5.329
MAS						
2013 ft / 0.26 / 48 °R	0.390	2.910	2.280	2.175	5.175	4.147
4181 ft / 0.26 / 48 °R	0.405	3.090	2.445	2.310	5.550	5.777
7431 ft / 0.26 / 48 °R	0.450	3.210	2.820	2.640	6.105	5.160
High speed idle with MAS						
2013 ft / 0.26 / 48 °R	0.360	2.865	1.905	1.815	4.815	3.792
4181 ft / 0.26 / 48 °R	0.360	3.060	2.010	1.935	5.130	4.146
7431 ft / 0.26 / 48 °R	0.375	3.165	2.235	2.130	5.505	4.907

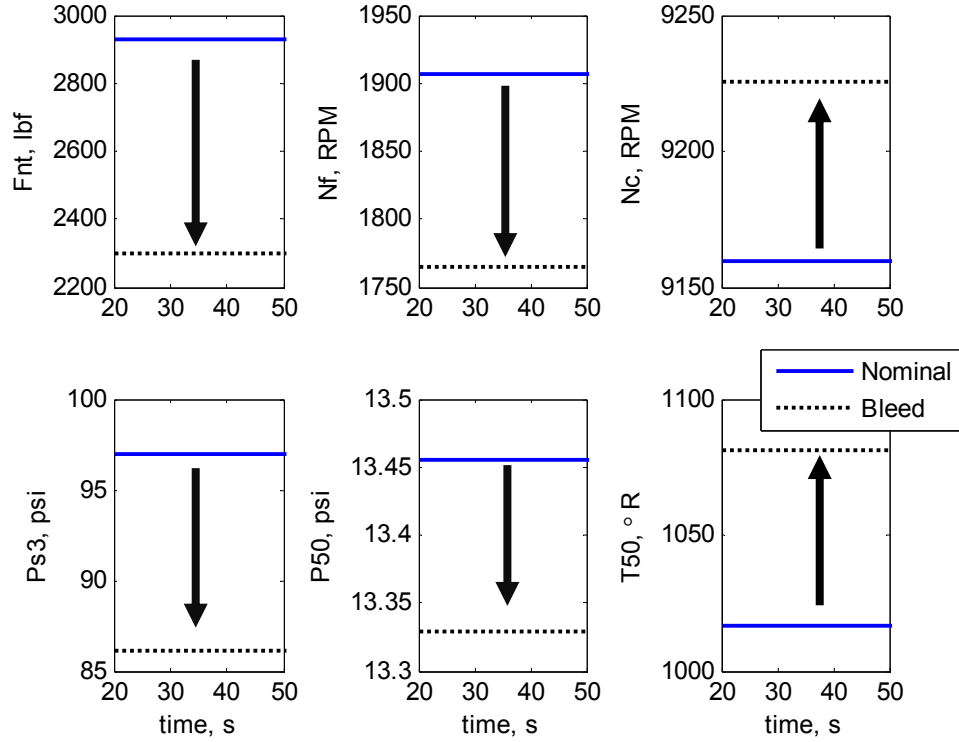

Figure 13.—Engine outputs showing the effect of bleeding off 10 lb/s from the core flow (4,181 ft, 0.26 Mach, standard day temperature, 50 hr engine).

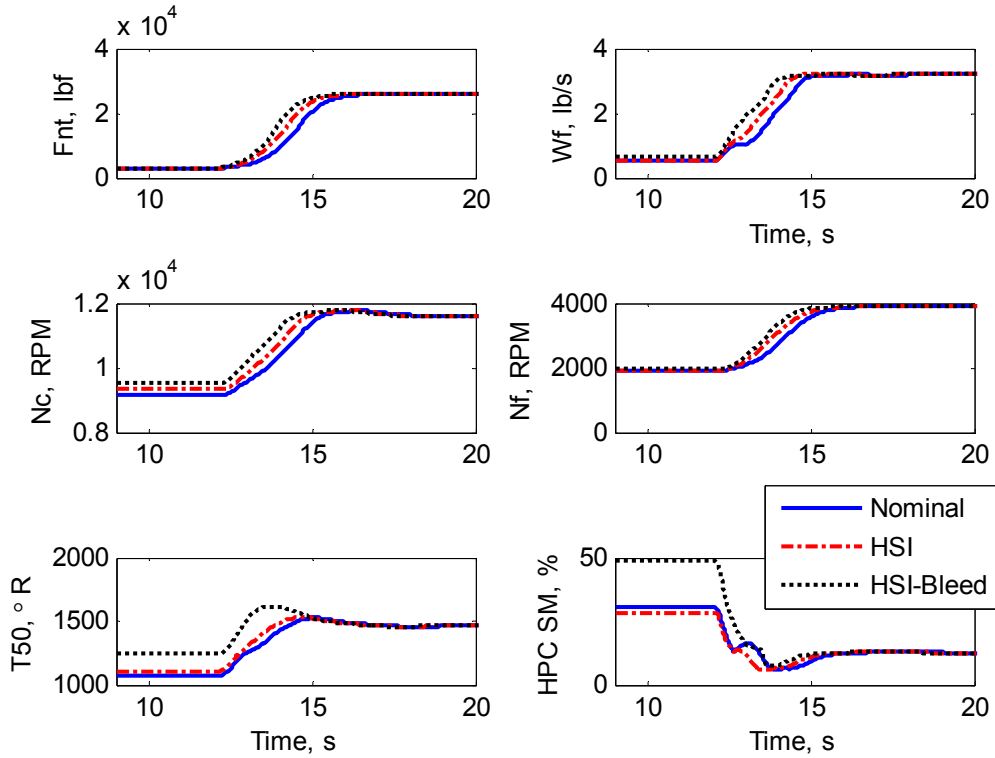

Figure 14.—Engine response comparing nominal, high speed idle with MAS (HSI), and high speed idle with MAS and customer bleed (HSI-bleed) (4,181 ft, 0.26 Mach, standard day temperature, end of life engine).



TABLE 9.—RESPONSE OF AN END OF LIFE ENGINE COMPARING THE NOMINAL, MAS, HIGH SPEED IDLE, AND HIGH SPEED IDLE WITH CUSTOMER BLEED VALVE, FOR A THROTTLE TRANSIENT FROM FLIGHT IDLE TO FULL POWER

Operating condition, alt, MN, dTamb	Td, s	Tr, s	Tde, s	Tc, s	Ts, s	SM, percent
Nominal						
2013 ft / 0.26 / 0 °R	0.385	2.055	2.440	2.265	4.180	7.360
4181 ft / 0.26 / 0 °R	0.385	2.130	2.530	2.37	4.465	5.955
7431 ft / 0.26 / 0 °R	0.385	2.295	2.590	2.475	4.840	3.631
MAS						
2013 ft / 0.26 / 0 °R	0.34	1.785	1.81	1.665	3.52	3.237
4181 ft / 0.26 / 0 °R	0.34	1.845	1.855	1.71	3.715	1.746
7431 ft / 0.26 / 0 °R	0.325	1.995	1.87	1.9	4.015	-0.605
High speed idle with MAS						
2013 ft / 0.26 / 0 °R	0.345	1.980	2.070	1.92	3.675	7.221
4181 ft / 0.26 / 0 °R	0.360	2.040	2.145	2.01	3.915	5.790
7431 ft / 0.26 / 0 °R	0.360	2.145	2.235	2.115	4.200	3.502
High speed idle with MAS and bleed valve						
2013 ft / 0.26 / 0 °R	0.360	1.830	1.815	1.65	3.450	6.915
4181 ft / 0.26 / 0 °R	0.345	1.890	1.845	1.71	3.615	5.887
7431 ft / 0.26 / 0 °R	0.345	2.010	1.890	1.785	3.870	4.306

## Summary

This paper presents the results of a sensitivity study using the Commercial Modular Aero-Propulsion System Simulation 40k (C-MAPSS40k) to obtain additional performance from a commercial aircraft engine in terms of additional thrust production and faster engine response during critical high risk situations. The main idea is to accept an increase in the risk of engine failure, but in return minimize the overall risk to the vehicle. This paper specifically investigates the risk of failure for either an increase in thrust production beyond the rated maximum, or an increase in the responsiveness of the engine to the pilot's throttle command.

For the overthrust scenario, this study indicates that additional thrust production is possible using the current controller architecture with an increase in the risk of failure due to increased turbine temperatures. To limit the amount of risk taken, a turbine temperature limit could be added to the control structure for overthrust operation only. In addition, the time for which the additional thrust is requested has a large impact on the risk of failure. It is worth restating that the risk model considered in the study of engine overthrust is only representative of the trends observed in the deterioration of an engine due to excessive temperatures and speeds. If and when a more accurate model is developed, these tests should be repeated.

In the fast engine response scenario, three different methods of increasing the responsiveness are proposed. The first is to modify the linear proportional integral controller implemented in C-MAPSS40k, which specifically addresses small throttle transients. This method involved modifying the integrator term, thus increasing the bandwidth, which causes a decrease in the stability margins (gain and phase). It was determined, based on the original design specification, that increasing the integral term by 40 percent would be the greatest modification that could be made and still maintain an appropriate amount of phase margin. Modification of the proportional integral controller will be used for any size throttle command, and is the only effective controller modification for small throttle commands when the protection logic controllers are not limiting the engine response.

The second method of increasing the responsiveness of the engine is to modify the acceleration schedule. This method involves adding an offset to the nominal acceleration schedule, which increases the performance at the cost of reduced stall margin. This method does work, but if the available stall margin is low, this method does not provide much improvement, thus it is only helpful for large throttle command at flight conditions where the available minimum stall margin is relatively high.

The final method to increase the responsiveness of the engine is to implement a high speed idle controller along with the other techniques. The idea behind the high speed idle control mode is to operate the engine at a higher core speed for a given amount of thrust during critical periods when increased responsiveness is warranted. Two modifications made to increase the core speed while maintaining the same thrust are to change the variable stator vane schedule, and to increase the flow rate through the customer bleed valve. In addition, the Ratio Unit minimum limiter is increased to ensure a higher idle power level, in terms of core speed. The data indicate that at worst there is a small reduction in the stall margin, while achieving a performance improvement in terms of decreased settling time, time constant, rise time, etc.

## References

1. May, R.D., Csank, J., Lavelle, T.M., Litt, J.S., and Guo, T.-H., "A High-Fidelity Simulation of a Generic Commercial Aircraft Engine and Controller," AIAA-2010-6630, 46<sup>th</sup> AIAA/ASME/SAE/ASEE Joint Propulsion Conference & Exhibit, Nashville, TN, July 25-28, 2010.
2. Csank, J., May, R.D., Litt, J.S., and Guo, T.-H., "Control Design for a Generic Commercial Aircraft Engine," AIAA-2010-6629, 46<sup>th</sup> AIAA/ASME/SAE/ASEE Joint Propulsion Conference & Exhibit, Nashville, TN, July 25-28, 2010.
3. Burcham, F.W., Jr, and Fullerton, C.G., "Controlling Crippled Aircraft—With Throttles," NASA TM-104238, 1991.
4. Burcham, F.W., Jr., Fullerton, C.G., and Maine, T.A., "Manual Manipulation of Engine Throttles for Emergency Flight Control," NASA/TM—2004-212045, January 2004.
5. Litt, J.S., Frederick, D.K., and Guo, T.-H., "The Case for Intelligent Propulsion Control for Fast Engine Response," AIAA-2009-1876, AIAA Infotech@Aerospace Conference, Seattle WA, June 6-9, 2009.
6. DeCastro, J.A., Litt, J.S., and Frederick, D.K., "A Modular Aero-Propulsion System Simulation of a Large Commercial Aircraft Engine," AIAA-2008-4579, 44th AIAA/ASME/SAE/ASEE Joint Propulsion Conference & Exhibit, Hartford, CT, July 21-23, 2008.
7. Jaw, L., and Mattingly, J.D., *Aircraft Engine Controls: Design, System Analysis, and Health Monitoring*, American Institute of Aeronautics and Astronautics, Inc., Virginia, 2009.
8. Litt, J.S., Sharp, L.M., and Guo, T.-H., "A Risk Assessment Architecture for Enhanced Engine Operation," AIAA-2010-3469, AIAA Infotech@Aerospace 2010, April 20-22, 2010, Atlanta, Georgia, July 2010.
9. Guo, T., and Litt, J.S., "Risk Management for Intelligent Fast Engine Response Control," AIAA-2009-1873, AIAA Infotech@Aerospace Conference, Seattle WA, June 6-9, 2009.
10. National Transportation Safety Board, "Aircraft Accident Report, United Airlines Flight 232, McDonnell Douglas DC-10-10, Sioux Gateway Airport, Sioux City, Iowa, July 19, 1989," PB90-910406, NTSB/AAR-90/06, 1990.

REPORT DOCUMENTATION PAGE			Form Approved OMB No. 0704-0188		
<p>The public reporting burden for this collection of information is estimated to average 1 hour per response, including the time for reviewing instructions, searching existing data sources, gathering and maintaining the data needed, and completing and reviewing the collection of information. Send comments regarding this burden estimate or any other aspect of this collection of information, including suggestions for reducing this burden, to Department of Defense, Washington Headquarters Services, Directorate for Information Operations and Reports (0704-0188), 1215 Jefferson Davis Highway, Suite 1204, Arlington, VA 22202-4302. Respondents should be aware that notwithstanding any other provision of law, no person shall be subject to any penalty for failing to comply with a collection of information if it does not display a currently valid OMB control number.</p> <p>PLEASE DO NOT RETURN YOUR FORM TO THE ABOVE ADDRESS.</p>					
<b>1. REPORT DATE (DD-MM-YYYY)</b> 01-04-2011		<b>2. REPORT TYPE</b> Technical Memorandum		<b>3. DATES COVERED (From - To)</b>	
<b>4. TITLE AND SUBTITLE</b> A Sensitivity Study of Commercial Aircraft Engine Response for Emergency Situations			<b>5a. CONTRACT NUMBER</b>		
			<b>5b. GRANT NUMBER</b>		
			<b>5c. PROGRAM ELEMENT NUMBER</b>		
<b>6. AUTHOR(S)</b> Csank, Jeffrey, T.; May, Ryan, D.; Litt, Jonathan, S.; Guo, Ten-Huei			<b>5d. PROJECT NUMBER</b>		
			<b>5e. TASK NUMBER</b>		
			<b>5f. WORK UNIT NUMBER</b> WBS 284848.02.05.03.10		
<b>7. PERFORMING ORGANIZATION NAME(S) AND ADDRESS(ES)</b> National Aeronautics and Space Administration John H. Glenn Research Center at Lewis Field Cleveland, Ohio 44135-3191			<b>8. PERFORMING ORGANIZATION REPORT NUMBER</b> E-17666		
<b>9. SPONSORING/MONITORING AGENCY NAME(S) AND ADDRESS(ES)</b> National Aeronautics and Space Administration Washington, DC 20546-0001			<b>10. SPONSORING/MONITOR'S ACRONYM(S)</b> NASA		
			<b>11. SPONSORING/MONITORING REPORT NUMBER</b> NASA/TM-2011-217004		
<b>12. DISTRIBUTION/AVAILABILITY STATEMENT</b> Unclassified-Unlimited Subject Categories: 07 and 63 Available electronically at <a href="http://www.sti.nasa.gov">http://www.sti.nasa.gov</a> This publication is available from the NASA Center for AeroSpace Information, 443-757-5802					
<b>13. SUPPLEMENTARY NOTES</b>					
<b>14. ABSTRACT</b> This paper contains the details of a sensitivity study in which the variation in a commercial aircraft engine's outputs is observed for perturbations in its operating condition inputs or control parameters. This study seeks to determine the extent to which various controller limits can be modified to improve engine performance, while capturing the increased risk that results from the changes. In an emergency, the engine may be required to produce additional thrust, respond faster, or both, to improve the survivability of the aircraft. The objective of this paper is to propose changes to the engine controller and determine the costs and benefits of the additional capabilities produced by the engine. This study indicates that the aircraft engine is capable of producing additional thrust, but at the cost of an increased risk of an engine failure due to higher turbine temperatures and rotor speeds. The engine can also respond more quickly to transient commands, but this action reduces the remaining stall margin to possibly dangerous levels. To improve transient response in landing scenarios, a control mode known as High Speed Idle is proposed that increases the responsiveness of the engine and conserves stall margin.					
<b>15. SUBJECT TERMS</b> Turbofan; Control; Risk; Sensitivity analysis; Engine control					
<b>16. SECURITY CLASSIFICATION OF:</b>			<b>17. LIMITATION OF ABSTRACT</b>	<b>18. NUMBER OF PAGES</b> 28	<b>19a. NAME OF RESPONSIBLE PERSON</b> STI Help Desk (email:help@sti.nasa.gov)
<b>a. REPORT</b> U	<b>b. ABSTRACT</b> U	<b>c. THIS PAGE</b> U			<b>19b. TELEPHONE NUMBER (include area code)</b> 443-757-5802



