

A Short Review on Basalt Fiber

Kunal Singha

Department of Textile Engineering, Panipat Institute of Engineering & Technology, Harayana, India

Abstract A hard, dense, inert rock found worldwide, basalt is an igneous rock, which is solidified volcanic lava. Cast basalt liners for steel tubing shows very high abrasion resistance in various industrial applications. In recent years, continuous basalt fibers extruded from naturally fire-resistant basalt are attracting attention as a replacement for asbestos fibers. In the last decade, basalt has emerged as a contender in the fiber reinforcement of composites. Some manufacturer of basalts claims it offers performance similar to S-2 glass fibers at a price point between S-2 glass and E-glass, and may offer manufacturers a less-expensive alternative to carbon fiber. Basalt fibre (BF) is capable to withstand very high temperature and can act as fire blocking element.

Keywords Cast Basalt, Fiber Reinforcement of Composites, S-2 Glass Fibers, Basalt Fibre (BF), Fire Blocking Element

1. Introduction

Today a significant growth is observed in the manufacture of composite materials. Intensively developed polymer composite materials (PCM) are used in different sectors of industry and technology. They are successfully replacing traditional construction materials and also permit the conditions that exclude use of metals. One of the basic reinforcing elements of composite materials is fibers. Glass fibers are widely used for making composites; carbon fibers are among the most effective and promising reinforcing fibers for creating PCM used in conditions of high loads. By producing of glass fiber especially scarce component are used - oxide boron (B_2O_3). Carbon fibers at their high cost have no prospects of mass application. In present time a several work is executed on development of modern continuous fibers from basalt stones. By industrial production of basalt fibers on the basis of new technologies their cost is equal and even less than cost of glass fiber. Thus basalt fibers and materials on their basis have the most preferable parameter a ratio of quality and the price in comparison with glass & carbon fibers, and other types of fibers[1]. Basalt originates from volcanic magma and flood volcanoes, a very hot fluid or semifluid material under the earth's crust, solidified in the open air. Basalt is a common term used for a variety of volcanic rocks, which are gray, dark in colour, formed from the molten lava after solidification[1- 4]. Basalt rock-beds with a thickness of as high as 200 m have been found in the East Asian countries. Russia has unlimited basalt reserves.

There are large deposits of these rocks in the Ural, Kam

chatka, Far East, Sakhalin, Kola Peninsula, Northwest Siberia, and the Transcaucasian. Basalt fiber is a material made from extremely fine fibers of basalt, which is composed of the minerals plagioclase, pyroxene, and olivine. Plagioclase is an important series of minerals within the feldspar family. The pyroxenes are a group of important rock-forming inosilicate minerals found in many igneous and metamorphic rocks. Inosilicates (from Greek[genitive: inos], fiber), or chain silicates, have interlocking chains of silicate tetrahedra with either SiO_3 , 1:3 ratio, for single chains or Si_4O_{11} , 4:11 ratio, for double chains. Igneous rock is formed through the cooling and solidification of magma or lava. Metamorphic rock is the result of the transformation of an existing rock type, the protolith, in a process called metamorphism, which means "change in form". The mineral olivine is a magnesium iron silicate with the formula $(Mg,Fe)_2SiO_4$. The mineral levels and chemical makeup of basalt formations can differ significantly from location to location. Moreover, the rate of cooling, when the original flow reached the earth's surface, also influenced the crystal structure. Its ready availability from mines and open-air quarries around the world, only a few dozen locations contain basalt that has been analyzed and qualified as suitable for manufacture of continuous thin filaments. Basalt formations in the Ukraine are particularly well suited to fiber processing. Basalt Rock fibers have no toxic reaction with air or water, are non-combustible and explosion proof. When in contact with other chemicals they produce no chemical reactions that may damage health or the environment. It has good hardness and thermal properties, can have various application as construction materials. Basalt is a major replacement to the asbestos, which poses health hazards by damaging respiratory systems. Basalt base composites can replace steel (1 kg of basalt reinforces equals 9.6 kg of steel) as light weight concrete can be get from basalt fiber[1-6]. As it is made of basalt rock is really cheap and has several excellent properties (good mechanical

* Corresponding author:

kunalsingha28@gmail.com (Kunal Singha)

Published online at <http://journal.sapub.org/textile>

Copyright © 2012 Scientific & Academic Publishing. All Rights Reserved

strength, excellent sound and thermal insulator, non-flammable, biologically stable, etc.). It has been made label-free material in the US and Europe. Also, particles or fibrous fragments due to abrasion are too thick to be respirable but care in handling is recommended.

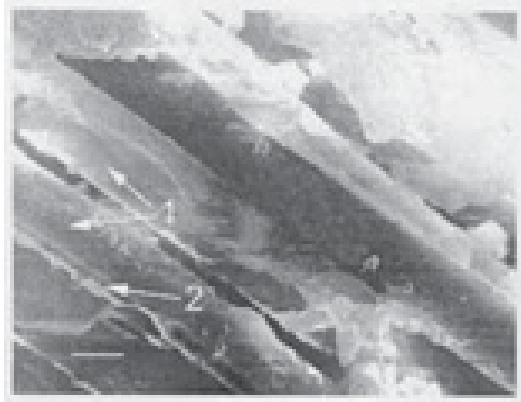

(a)

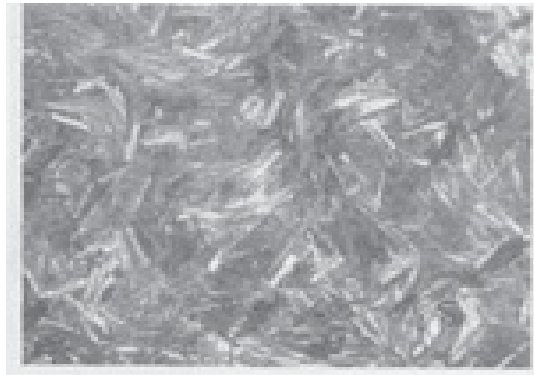

(b)

Figure 1. Structure of basalt-filled plastics: a) anisotropic; b) isotropic. 1) Basalt fiber, 2) Sections of polymer film[6]

2. Chemical Composition of Basalt Rock

Chemical Composition of Basalt rocks	%
SiO ₂	52.8
Al ₂ O ₃	17.5
Fe ₂ O ₃	10.3
MgO	4.63
CaO	8.59
Na ₂ O	3.34
K ₂ O	1.46
TiO ₂	1.38
P ₂ O ₅	0.28
MnO	0.16
Cr ₂ O ₃	0.06

3. Spinning of Basalt Fiber

As natural product basalt stones are found in different compositions, only certain compositions can be used for making continuous filaments with a diameter range of 9 to 24 microns. SiO₂ content about 46% (acid basalt) in basalt rocks are suitable for fiber production. In a single step process basalt continuous filaments (BCF) can be prepared from basalt rocks by melting and extrusion process. The BF was produced by Junkers technology (Toplan Ltd., Tapolca, Hungary). Basalt fiber is produced in a continuous process like glass fibers. Figure 2 shows the Junkers type BF production by melt blowing. Quarried basalt rock is crushed, washed and loaded into a bin attached to feeders that transfer the material into melting baths in gas-heated furnaces. The process is much simpler than glass fiber processing as basalt fiber has a less complex composition. Glass is typically 50 percent silica and consists of boron oxide, aluminum and several other minerals - materials that must be fed independently into a metering system before entering the furnace. Unlike glass, basalt fibers feature no secondary materials. The process requires a single feed line to carry crushed basalt rock into the melt furnace. As basalt stone is procured from nature, basalt fiber manufacturers have less direct control over the purity and consistency of the raw basalt stone. Mineral levels and chemical composition of basalt formations can differ significantly from one location to other location. Basalt and glass are both silicates, molten glass, when cooled, forms a noncrystalline solid, the rate of cooling, and also influenced the crystal structure. Crushed basalt enters the furnace, the material is liquefied at a temperature of 1500 °C (glass melt point varies between 1400 °C and 1600°C). Opaque basalt absorbs rather than transmits infrared energy unlike glass which is transparent. Use of overhead gas burners used in conventional glass furnaces is more difficult for uniformly heat the entire basalt mix. With overhead gas, the melting basalt must be held in the reservoir for extended periods of time - up to several hours - to ensure a homogenous temperature. Basalt producers have employed several strategies to promote uniform heating, including the immersion of electrodes in the bath. Finally, a two-stage heating scheme is employed, featuring separate zones equipped with independently controlled heating systems. Only the temperature control system in the furnace outlet zone, which feeds the extrusion bushings, requires great precision, so a less sophisticated control system may be used in the initial heating zone[2, 4]. Basalt fibers are typically produced by two different technologies. The so-called blowing technology with centrifugal cylinders (e.g. Junkers method) is used for manufacturing cheap fibers with 60–100 mm length and 8–20 μm diameter, primarily used as insulating materials in the construction and automotive Industries. The BF used in the thermoplastic and thermoset composites reported here was produced by the so-called Junkers technology (Toplan Ltd., Tapolca, Hungary). The basalt melt coming from the 1580°C furnace is fed to a horizontal shaft fiber spinning machine. This has three centrifugal heads and consists of one accelerating and two fibrillizing cylinders[8,

9]. The fibers formed as a result of the centrifugal force are blown off with high-pressure air as depicted in figure 1 & 2.

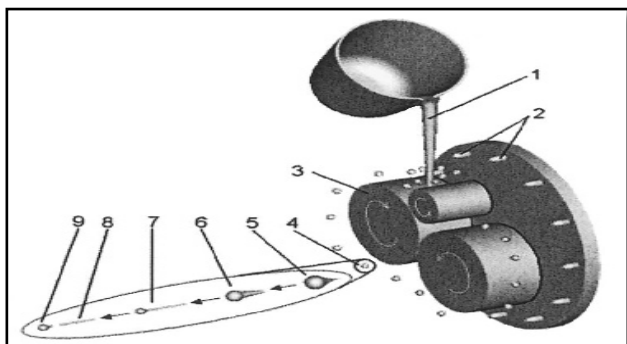

Figure 2. Scheme of the Junkers type BF production by melt blowing: 1 -molten basalt rock, 2 - blowing valves, 3 - fibrillizing cylinder, 4 -droplets, 5-7 fiber formation, 8 -fiber, 9 -fiber head[7]

For more demanding applications continuous fibers, which can be processed by textile technologies, are prepared by spinneret technology from the melt - similarly to traditional glass fiber production (Figure 3). These continuous fibers of 10–14 μm diameter can be obtained in the form of rovings containing different numbers of elementary fibers. Short fibers can be produced directly from crushed basalt stones and the technology is very simple so the fibers are very cheap, but they have relatively poor and uneven mechanical properties. An important application of basalt fibers is the substitution for asbestos, e.g. in car brake pads, due to its high temperature resistance[8, 13].

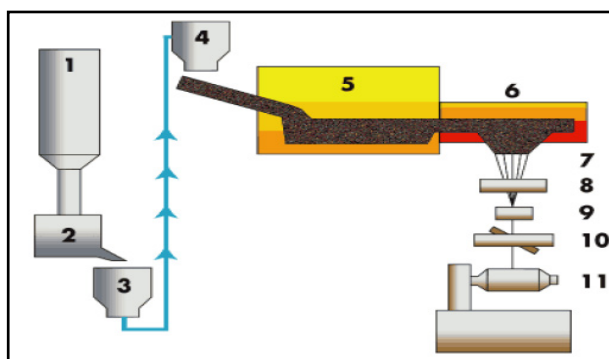

Figure 3. Diagram of basalt fiber spinning: 1) Crushed stone Silo, 2) Loading station, 3) Transport system, 4) batch charging station, 5) Initial melt zone, 6) Secondary controlled heat zone, 7) Filament forming, 8) Sizing applicator, 9) Strand formation, 10) Fiber tensioning, 11) Winding

From furnace, molten basalt is fed through feeder channel and feeder window communicates with the recuperator. The feeder has a window with a flange connected with slot-type bushing and is heated by furnace waste gases. The melt flows through electrically heated platinum/rhodium bushing with 200 holes (500 is possible). The fibers are drawn from the melt under hydrostatic pressure and subsequently cooled to get hardened filaments. Silane based sizing liquid is applied to impart strand lubricity, integrity and resin compatibility. Filaments 'strand' are collected together and forwarded to wound on take up device. Basalt twisted yarn is produced by twisting the basalt roving. Continuous basalt filaments are

chopped to a specific fiber length in a dry cutting process to get staple fiber. The moisture content of final fiber is less than 1% and with sizing add on it ranges from 1.0% - 2.0%. Though the Junkers type BF production by melt blowing technology is very efficient and cheap but the disadvantages are also there. Molten basalt is cooled down gradually from very high temperature to get fiber and hence smaller or larger "heads" remain at their ends depending on fiber length and affect adversely to the strength and toughness of fiber. Molten basalt is non-homogeneous in nature and shows nonuniform temperature distribution during production stage. Precise temperature maintenance and control system at multiple stages is needed. Instead of conventional heating microwave heating can be used for proper heat distribution and lower preheating time. The main problem in manufacturing of basalt fibers is the gradual crystallisation of various structural parts like plagioclase, magnetite and pyroxene. This arises mainly because of difference in the crystallisation temperature (T_c) of the different components, which varies from 720°C - 1010°C (magnetite T_c - 720°C, pyroxene T_c - 830°C and plagioclase T_c - 1010°C). Fresh basalt fibers are practically amorphous when the rapidly quenched, due to the action of high temperature these fibers develop the ability to crystallize partially. A slow cooling of these fibers leads to more or complete crystallization to form an assembly of minerals. Trivalent rare earth ions present in basalt have same size as the divalent calcium ions. So the rare earth elements fit into the crystal lattices of calcium bearing rock forming minerals such as pyroxene (CaMgSiO_3) and plagioclase ($\text{CaAl}_2\text{SiO}_8$). Research works are being carried out to develop the means to draw the as-spun, spun filaments between rollers to modify the physical properties and to apply the surface finishes to the filaments to suit the specific applications. The fibers may be used either as a filament or staple fiber as per the requirement. Basalt roving (Figure 4a) is produced by assembling a bundle of strands into a single large strand.



Figure 4. (a) Basalt fiber (b) Preforms for composite

Manufactured basalt fibers have a fineness of 9 μ - 22 μ (chopped fibers 10 μ - 17 μ) and 320tex - 4800 tex for roving. Possibility of the production of basalt and glass fabric for the electrical insulation and construction application has been demonstrated (Figure 4b). The magnitude of specific volume electrical resistance was found one order higher than that of the glass cloth[4, 7, 9-10].

3.1. Characteristics of Basalt Fiber

Rock wool fibers can be characterized by their acidity modulus, M_s , which describes the ratio of acidic to basic

oxides. If $M_s < 1.2$, the fiber is called slag wool, the base material of which is cinder. But they are very brittle and show a poor chemical resistance. If $M_s = 1.2 - 1.5$, the fiber is considered to be a mineral wool, the base materials of which are basic volcanic rock and cinder. These fibers are brittle, but have acceptable insulation properties; hence their significance in the construction industry is high. If $M_s > 1.5$, the fiber is called rock wool and if its base material is basalt then it is named basalt wool (basalt fiber, BF). Due to the conditions of its formation, basalt has several excellent properties. Like high elasticity modulus, excellent heat resistance, its fibers have a significant capability of heat and acoustic damping and are outstanding vibration isolators [7]. Like many other minerals and 100% inorganic colour of basalt varies from dark gray to black. The natural golden-brown appearance of fabrics, as it is can be used for decorative purposes. Basalt fibers has attracted its attention for its high modulus, high strength, corrosion resistance, high temperature resistance, extended operating temperature range and easy to handle. The basalt has low density like 2.8 g/cc to 2.9 g/cc, which is much lower than metal (steel) and closer to carbon and glass fibers though cheaper than carbon fiber and high strength than glass fiber. Hence basalt is suitable as low weight cheaper tough composite materials. Moisture regains and moisture content of basalt fibers is less than 1%. The main advantage of basalt fibers are resistance to alkaline environment as it can withstand pH up to 13 - 14 and relatively less stability in strong acids. They can retain up to 92% of their properties in 2 (N) NaOH and up to 75% of their properties in 2 (N) HCl acid and results in weight loss of only 5.0% and 2.2% respectively but these conditions lead to severe damage in the case of glass fibers. Figure 5-7 shows the comparison of damage of basalt, carbon and glass fibre

under alkaline condition. Basalt materials have strong resistance against the action of fungi and micro-organisms. Easy damage of fabrics after weaving happened due to poor bending property of basalt results in and, further, needs to be stabilized with some coating. Basalt material is extremely hard and has hardness values between 5 to 9 on Mohr's scale, which results in better abrasion properties. Even continuous abrasion of the basalt fiber-woven fabrics over the propeller type abraders do not generate fine fibers or splitting of fibers by fracture and results only in breaking of individual fibers from the woven structure which eliminates possibility of causing hazards related to respiration. The fractures in the fiber mainly occur due to the non-homogeneities in the fiber volume. Basalt fibers exhibit catastrophic failures at specific places depending upon the critical defect size present in the fibers. Since the defects are present randomly in the fibers, this also leads to mutually independent, multiple failures. Reheating at lower temperatures and weathering the crystallized basalt materials results in the formation of un-consolidated layers of substances (regolith) especially over the exterior surface, mainly because of the reduction reactions. Basalt fibers have an excellent thermal properties compared to that of glass (E-type) and can easily withstand the temperature of 1100°C - 1200°C for hours continuously without any physical damage. Unstressed basalt fibers and fabrics can maintain their integrity even up to 1250°C, which makes them superior compared to glass and carbon fibers. The good insulation property of basalt was recognized earlier, that is why it is a widespread insulation material in the construction industry, processed in the form of rockwool [4, 7- 8, 10-13]. Table 1-2 describes the comparison of mechanical and thermal properties of basalt and other important fibres for composites.

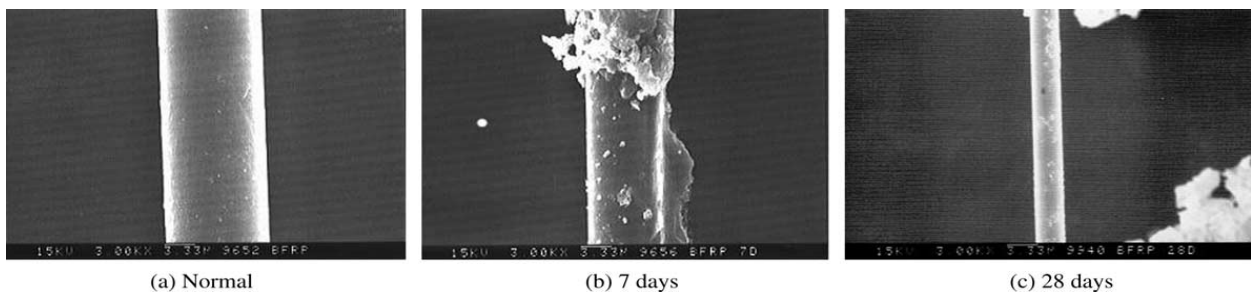

Figure 5. SEM images (3KX) of basalt fibers under NaOH solution [12]

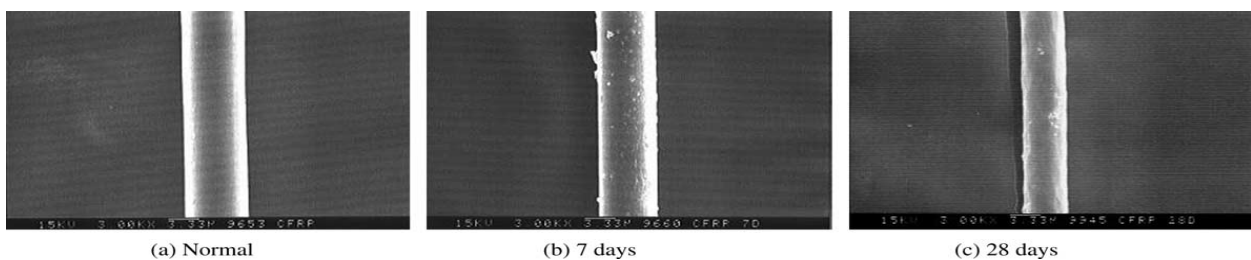

Figure 6. SEM images (3KX) of carbon fibers under NaOH solution [12]

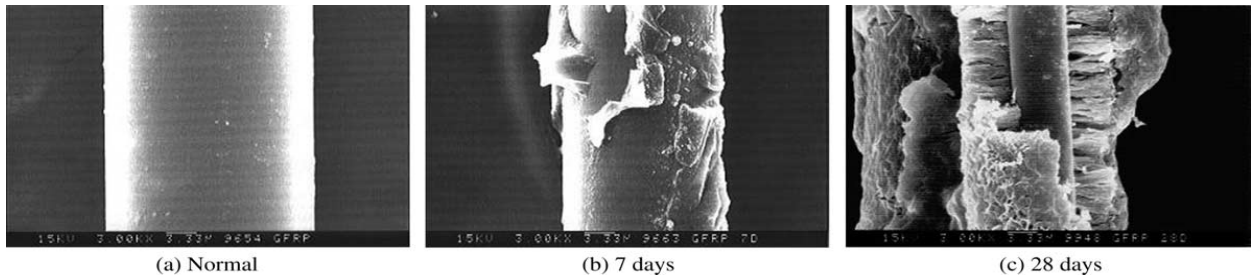

Figure 7. SEM images (3KX) of glass fibers under NaOH solution[12]

Table 1. Mechanical and physical properties of basalt fiber[20]

Properties	Continuous Basalt fiber	Glass fiber (E-glass)	Glass fiber (S-glass)	Carbon fiber
Breaking Strength (Mpa)	3,000 – 4,840	3,100– 3,800	4,020–4,650	3,500– 6,000
Modulus of Elasticity (Gpa)	79.3 – 93.1	72.5 – 75.5	83 - 86	230 - 600
Breaking Extension (%)	3.1	4.7	5.3	1.5 ~2.0
Fiber Diameter (μm)	6 - 21	6 - 21	6 - 21	5 - 15
Linear Density (tex)	60-4,200	40-4,200	40-4,200	60-2,400
Temperature Withstand ($^{\circ}\text{C}$)	-260....+700	-50....+380	-50....+300	-50....+700

Table 2. Thermal properties of basalt fiber[10]

Thermal properties	Basalt	E-glass
Maximum operating temperatures	980 $^{\circ}\text{C}$	650 $^{\circ}\text{C}$
Sustained operating temperatures	700 $^{\circ}\text{C}$	480 $^{\circ}\text{C}$
Minimum operating temperatures	-2.60 $^{\circ}\text{C}$	-60 $^{\circ}\text{C}$
Thermal conductivity	0.031-0.038 W/m K	0.034-0.04 W/m K
Melting temperature	1,280 $^{\circ}\text{C}$	1,120 $^{\circ}\text{C}$
Thermal expansion coefficient	8.0 ppm/ $^{\circ}\text{C}$	5.4 ppm/ $^{\circ}\text{C}$

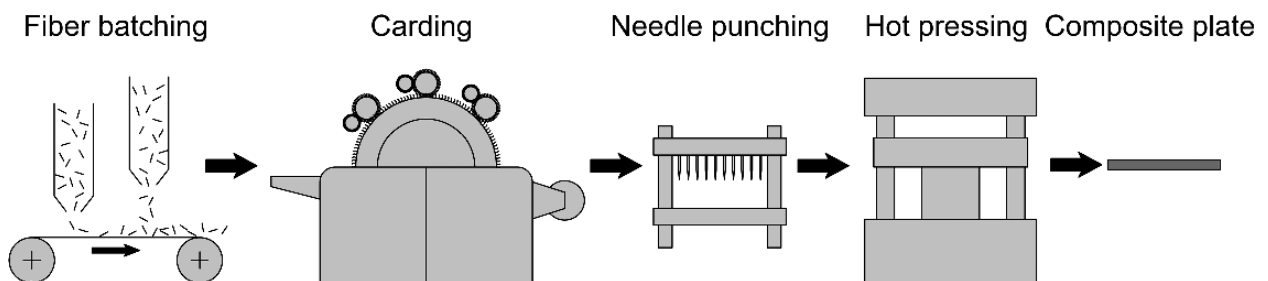

Figure 8. Manufacturing process of composite plates

4. Manufacturing of Composites

The composites were produced by pressing technique. Glass and continuous basalt (BF-S) fibers were chopped to a length of 60 mm for carding. PP fibers were used as matrix material and acted as carrying fibers. PP fibers were fed into carding machine (BEFAMA 3K type multi-cylinder carding machine) together with the basalt and glass fibers. The

nominal fiber content was 30 mass percentage (m%) in each case. The carded pre-fabricates were needle punched and as a result became more consistent and contained less air inclusions. Three millimeter thick plates were produced from the materials prepared in the way mentioned above with pressing on a Schwabenthan Polystat 300S type pressing machine, at the temperature of 200 $^{\circ}\text{C}$ and pressure of 20 bar. The manufacturing process can be seen in Figure 8[8].

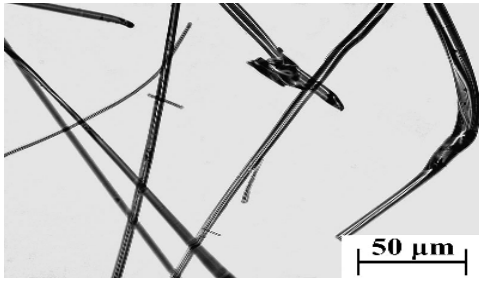

Figure 9. Optical micrograph of blown basalt (BF-B) fibers

Spun and blown basalt fibers and their PP matrix composites were investigated. The composites were manufactured by hot pressing technology from carded and needle punched prefabricate using PP fiber as matrix material. Glass and blown basalt fibers were treated with reaction product of maleic acid-anhydride and sunflower oil while spun basalt fibers had a surface coating of silane coupling agent. Fibers were investigated with tensile tests while composites were subjected to static and dynamic mechanical tests. Blown basalt fibers have relatively poor mechanical properties, while spun basalt fibers are comparable with glass fibers regarding geometry and mechanical performance[8].

4.1. Hybrid Composite

Continuous basalt fiber is well compatible with other materials and many complex materials can be made with them. Combination of continuous basalt fiber with carbon fiber can be used as reinforce concrete, asphalt concrete, building constructions. Continuous basalt fiber and carbon fiber have rather high characteristics, and they are significantly cheaper than materials made only from carbon fiber, and that opens up a wide prospect for their mass application. Basalt fiber properties, like stability in high temperatures, acids and especially alkalies make basalt fiber called-for in construction as:

- Reinforcing material for concrete and asphalt concrete covers of motor roads, takeoff and landing strips and taxiway of airfields.

- Chemical - and corrosion-resistant reinforcement, the strength of which exceeds the strength of a alloy steel several times.

- Incombustible and fireproof composites for nuclear and thermal power plants, oil-processing and chemical factories, dwarf wall (fire-resistant constructions) of skyscrapers and other important industrial objects where the beginning and spreading of fire are inadmissible.

- Chemical- and wear-resistant covers, composites.

- Filters for industrial and domestic gutter filtration, filters for smoke and dust emissions of industrial enterprises.

Hybrid composites contain two or more different types of reinforcement fibers with different mechanical and other properties. The purpose of hybridization is to achieve a composite architecture which synergizes the properties of both materials and lowers the cost. Structures of hybrid composites may be classified as interply hybrids, intraply hybrids, intimately mixed (intermingled) hybrids, selective placement and super hybrid composites. Brittle inorganic fibers and ductile organic fibers are often combined to make hybrid composites such as palm/glass, tong glass/mineral fiber, aramid/glass, etc. 3D woven basalt/aramid hybrid composites (Figure 10) with similar fiber volume fraction and dimension were designed and fabricated, namely interply and intraply hybrid composites. 3D woven composites shows better mechanical and physical properties compared with their 2D woven and also have a reasonable cost due to their relatively simple resin impregnation process and high performance because of their resistance to delamination. 3Dcomposites is well known for its ballistic impact damage resistance and low velocity impact tolerance. Low velocity impact properties of 3D woven composites are important when tools are dropped on the surface of a composite or when the material is impacted by debris, fragments, or projectiles. Low velocity impact properties of 3D woven basalt/aramid hybrid composites were tested. The interply hybrid composite had higher ductile indices, lower peak load, and higher specific energy absorption in both warp and weft directions than those of the intraply hybrid composite[14].

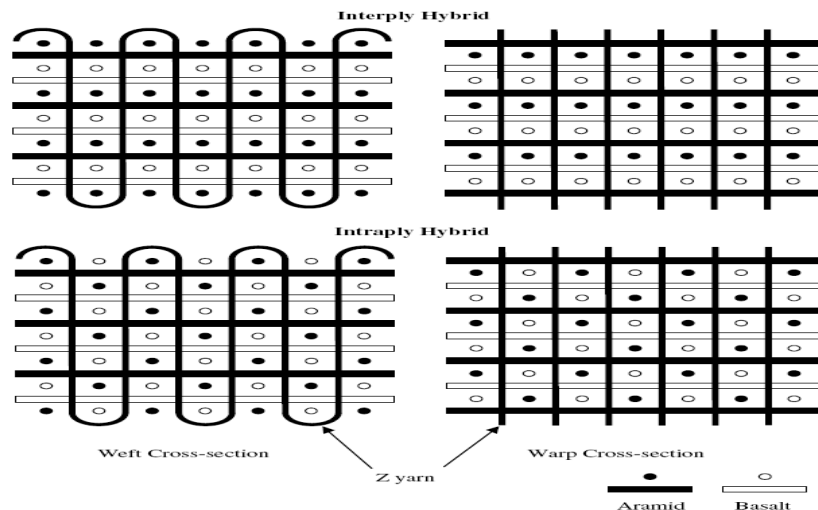

Figure 10. 3D woven basalt/aramid hybrid composites with similar fiber volume fraction and dimension[14]

Hybridization of carbon fiber with basalt fiber significantly increases production of carbon-fiber-reinforced plastics, which allows expanding the areas of application of these effective materials for special purposes, in machine building, auto and rail transport, in the river and marine fleet, etc. Hybridization of carbon fibers with 30-40% basalt fibers will stimulate the development of the basalt fiber, yarn, and fabric sector, which will reduce their cost and expand the areas of application particularly for roads and transportation. Cost of the hybrid composites is much lower than the cost of carbon-fiber-filled plastics and the physicochemical characteristics increase, approaching the characteristics of the stronger carbon-fiber-filled plastic. Hybridization of CF with GF is less effective than with BF. When CF is combined with 40% GF, the strength and hardness of the carbon-fiber-filled plastic decreases by 50 and 44%, respectively. The combination of CF with 40% BF thus decreases the mechanical characteristics of the hybrid CF by a total of 12-14%, increases the water resistance by 70%, and reduces the cost sharply, by several times [15].

5. New Approach: Modification of Basalt Fiber Manufacturing Line

It is reported that basalt fibers can be used as reinforcing materials in a polypropylene (PP) matrix. Fracture toughness of composite increases as a result of reinforcing due to brittle character of basalt fiber. The toughness of the composite increased compared to the matrix due to the gravels appeared at the end of basalt fibers. It has been pointed out that the gravels are results of the Junkers production technology. The observations have also been proven by electron microscopic images (Figure 11, 12).

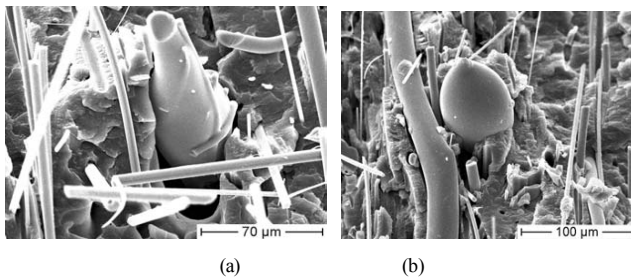

Figure 11. SEM picture of the presence of fiber heads (gravels) in the composite

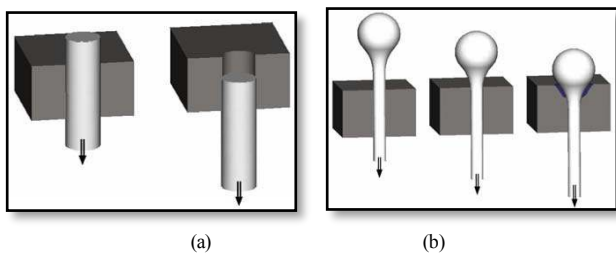

Figure 12. (a) Fiber pullout from the matrix without fiber head, (b) model of the toughness increase caused by fiber head during fiber pullout

The production of basalt fibers with more or less gravels was attempted by the further examination of gravels and the

optimization of the technology (further modification of the e.g. temperature of the melt, disk speed, air flow rate etc.). A model has been outlined for investigation of influence of change of technological parameters on basalt fiber production. The model aims at providing guidelines how the parameters of the Junkers technology (i.e. basalt melt temperature, r.p.m. of fiberization disks, velocity of air jets etc.) influence the geometry of basalt fibers produced. The formation of basalt fibers is a very complex process. The basalt melt originated from the gas-heated furnace operating at melting temperature of approx. 1580°C is lead to a fiberization equipment comprising three rotating disks of horizontal axis (Fig. 13a). First the melt is run to an accelerating disk of smaller diameter and higher speed. The accelerating disk forwards the melt to two consecutive fiberization disks (Fig. 13b). A melt layer develops on the surface of the fiberization disks. The fiber formation process shows certain analogy with the operation of rotary disk atomizers. Due to the centrifugal forces, droplets protrude from the melt layer. When reaching a critical size, the droplets are detached from the disks, hauling fibers along.



(a)

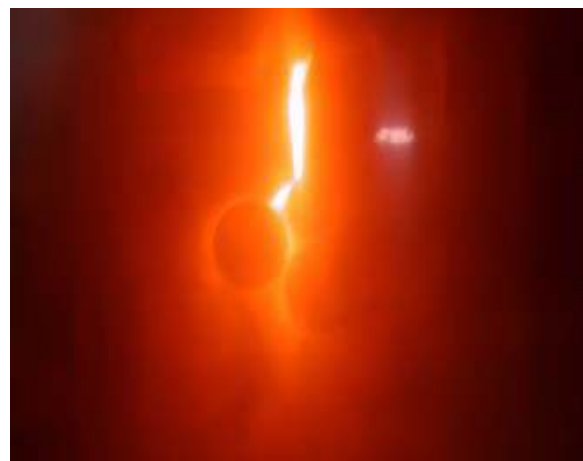

(b)

Figure 13. a) the process of fiber spinning, the accelerating disk is above, the centrifugal disks are below, b) formation of a melt film

A model has been presented for formation of a droplet from a motionless liquid layer. It has been pointed out that the size of initial basalt droplets is inversely proportional to the r.p.m. of the fiberization disks. Therefore, the alteration

of disk speed is concluded to be an effectual way of fiber and gravel geometry[13].

6. Applications of Basalt Fiber

Considering the competition in the market and the ever-increasing economic and environmental requirements for reinforcements in polymer composites, the reinforcement potential of newer and newer fibers is investigated in the leading research institutes of the world. Basalt fiber is a possible polymer reinforcing material and can be applied in polymer matrix composites instead of glass fiber. Basalt fiber can be reinforced in thermosetting polyester matrix composites. It was established that the surface treatment of basalt fiber with silanes improved the adhesion to the matrix, reflected also in the bending strength of the composites. Single basalt fiber treated with 3-aminopropyltriethoxy-silane and dimethoxysilane increased the interfacial shear strength. The increasing application of basalt is noticed as an insulating material in the construction and automotive industry and less hazardous than asbestos fiber. Basalt fabrics are produced for the structural, electro-technical purposes. Structural applications include electromagnetic shielding structures, various components of automobiles, aircraft, ships and household appliances. Fabrics of varying surface densities are made depending upon the application type and are in the range 160 g/m² to 1100 g/m² for the insulation type of applications. Basalt fibers reinforced in the glass matrix can be viably used for opto-mechanical applications. Processing of basalt fibers does not require special equipment or technologies - all known processes including pultrusion, filament winding, SMC/BMC as well as conversion into regular textile, non-woven, UD and multi-axial fabrics can be used. Wide application of our basalt fiber in following industry fields: building, automotive industry, boat building, wind mill blades manufacturing etc[16].

6.1. Nuclear Power Engineering

Basalt materials do not absorb the radioactive radiations, which makes them to consider as the potential material in production and transformation of radioactive materials, in nuclear power plants. Protective cap using geo-composites in the waste disposal sites, incorporating basalt materials, can offer the best protection for the human health and environment against the radioactive wastes[5].

6.2. Civil Construction and Concrete Reinforcements

Requirements of the moderate strengthening in the civil structures and high fire resistance can be met with basalt fibers while FRP strengthening can be considered for pure strengthening. Applicability of basalt fibers as a strengthening for concrete structural materials has been studied for durability, mechanical properties and flexural strength. Basalt filaments incorporated unidirectional rods are used as the reinforcement of concrete slabs in hydraulic engineering and

construction in seismically hazardous regions. There are two methods, wet and dry, for production of basalt cloth that allows one to prepare cloth of different types. Basalt fibers in a basalt cloth form a regular pattern in which they are cross-linked by means of organic additives, mostly thermo reactive resins. The basalt cloth is a porous material which allows easy impregnation; furthermore, it exhibits a high chemical stability and sealing, anticorrosion and fire-proof properties, and finds multiple uses in the production of insulating materials, in the automotive industry, civil engineering, etc. The basalt cloth can also be used as a reinforcing material, as stabilizing or separating layers, as a material for surface finish, or for sound insulation. For floating concrete pontoons, steel is used, with time salt water is penetrating into concrete and will come into contact with the steel reinforcement causing to rust and crack the concrete. Designing of new reinforcement which is a non corrosive, non magnetic and non electric leading material and has a longer life can replace the steel reinforcement[2, 17-18].

6.3. Basalt Fiber Composites-Tissues, Plastics, Prepregs And Laminates

A very high Young's modulus, ultimate tensile strength and good wetting properties of basalt filaments can be utilized for making high performance composites. Basalt fiber tissue is a non-woven material, composed of uniformly distributed basalt fibers, bound by organic additives like thermosetting resins. Its porosity makes easy to impregnate and also possesses better resistance against atmospheric agents, UV rays, acids, and alkalis. Different binders like foro-phenolic, melamine, latex, urea formaldehyde or PVA can be used for making basalt tissues. Basalt tissues can be used as soft roofing and water proofing using bituminous coatings, geotextiles, anti-corrosion material, plastic foams with PU foam linings, tissue tapes for joining two boards, batter plate separators and etc. Basalt plastics based on various thermosetting binders, phenolic polyesters through the laying out method, suitable for automobile, aircraft, ships and households appliances. Basalt fiber reinforced plastics are more suitable for painting because of their better surface quality. This, also, can be electroplated without imparting any pretreatment to this material[4, 19].

6.4. Electro-technical Application

Basalt fabrics for electro-technical purposes are used as a base for the production of insulation materials, have superior properties to conventional fiber glass material. Preliminary metallization of the fabrics result in shielding properties of electromagnetic radiations. Basalt can be used over a wide temperature range from about -260°C/-200°C to 650°C/800 °C compared to E-glass which can be used from - 6°C to 450°C/600°C. It can replace asbestos in almost all applications because of its heat insulating properties. Because of its good insulating properties, it can replace glass materials. Tapes made from the basalt material can be used in the electrical cables as the insulation material against fire haz-

ards during power transmission. Even at very low temperatures, the basalt fibers attain their properties, which make this material suitable for low temperature insulations. In power industries the basalt fiber is used in following cases: fire resistant cable construction components as fillers, braiding, tapes etc. In transformer stations: screens, protection, and insulation; motor insulation: tapes etc.[4, 9, 17].

6.5. Industrial Applications

Basalt fibers, as a sewing thread, attract major attention in the high temperature application for stitching of filter bags for hot media, filter bags intended for highly aggressive chemical environment. Incombustible basalt fabrics inserts in industrial ventilators increase their fire safety. Automobile, aircraft, ship and household appliances using basalt are made with incorporating thermosetting resins such as epoxy and phenolic resins in the form of prepegs, laying out. Lubricated, chopped fibers are used in car brakes etc. the ability to recycle the basalt fibers to different forms solves the problem of disposal of the scraps, and different degraded components obtained from various applications. Basalt fibers reinforced cardboard with suitable binders like PVA can be used for cryogenic applications that are required for storing biological materials in liquid nitrogen atmosphere. Basalt fibers can also be used in the various agricultural applications like, land drainage pipes, pipes for irrigation and hosing, raising vegetable and seeding, and agricultural machine construction[20].

6.6. Hot Gas Filtration

The development of new high-temperature synthetic fibers like basalt has led to increased use of hot gas filtration for industrial applications. Glass fiber materials can be operated at 30°C-260°C, but they have certain shortcomings. Polyimide fibers possess good performance characteristics but are inclined to severe shrinkage at 260°C. Membrane filters made from glass fabrics covered with porous fluoropolymer have low permeability, which results in higher operating costs for filtration. Fabrics made from polytetrafluoroethylene (PTFE) fibers demonstrate excellent performance they are expensive and also shrink at elevated temperatures. Basalt composite filter fabrics can be successfully used for cleaning corrosive hot gases, or waste air containing hot particles having temperatures over 800°C and also long lasting[21].

7. Conclusions

The basalt fiber is now being a popular choice for the material scientist for the replacement of steel and carbon fiber due to its high rigidity and low elongation or extension at break. Its supreme tenacity value makes it as a useful reinforcement material in the present and also for the future era to come.

REFERENCES

- [1] <http://basaltfm.com/eng/index/html>; dt 12/10/2010.
- [2] Gajanan Deshmukh; Basalt - The Technical Fibre; Man-made Textiles in India; July 2007; 258-261.
- [3] <http://www.seminarprojects.com/Thread-basalt-rock-fibre-brf>; dt 14/10/2010.
- [4] D Saravanan; Spinning the Rocks - Basalt Fibres; Journal of the Institution of Engineers (India): Textile Engineering Division, Feb2006, Vol. 86, p39-45.
- [5] S. E. Artemenko, Y. A. Kadykova; Polymer composite materials based on carbon, basalt, and glass fibres; Fibre Chemistry, Vol. 40, No. 1, 2008
- [6] V. V. Pakharenko, I. Yanchar, V. A. Pakharenko, V. V. Efanova; Polymer composite materials with fibrous and disperse basalt fillers; Fibre Chemistry, Vol. 40, No. 3, 2008.
- [7] Tibor Czighny; Polymer composites, 2005, Part IV, 309-328, DOI: 10.1007/0-387-26213-X_17, Chapter 17, Discontinuous Basalt Fiber-Reinforced Hybrid Composites.
- [8] T. Czigány, T. Deák, P. Tamás; Discontinuous basalt and glass fiber reinforced PP composites from textile prefabricates: effects of interfacial modification on the mechanical performance; Composite Interfaces, Vol. 15, No. 7-9, pp. 697-707 (2008).
- [9] Jean Marie Nolf. 'Basalt Fibres - Fire Blocking Textiles; Technical Usage Textile, no 49(3rd qrt), 2003,pp 38 - 42.
- [10] Ms. Hireni Mankodi Sr.Lecturer; New reinforced material for textile composite - basalt fiber; www.fibre2fashion.com, dt 12/10/2010.
- [11] A. A. Dalinkevich, K. Z. Gumargalieva, S. S. Marakhovsky, A. V. Soukhanov; Modern basalt fibrous materials and basalt fiber-based polymeric composites; *Journal of Natural Fibers*, 6, 248-271, 2009
- [12] J. Sim, C. heolwoo Park, D. Y. Moon; Characteristics of basalt fiber as a strengthening material for concrete structures; Composites: Part B 36 (2005) 504-512
- [13] Tibor Czighany, János Vad; Kornél Pölöskei; Basalt fiber as a reinforcement of polymer Composites; *Periodica polytechnica ser. Mech. Eng. Vol. 49, No. 1, PP. 3-14 (2005).*
- [14] X. Wang B. Hu, Y. Feng F. Liang J. Mo, J. Xiong, Y. Qiu; Low velocity impact properties of 3D woven basalt/aramid hybrid composites; *Composites Science and Technology* 68 (2008) 444-450.
- [15] S. E. Artemenko, Yu. A. Kadykova ; Hybrid composite materials; Fibre Chemistry, Vol. 40, No. 6, 2008.
- [16] <http://www.basfiber.com/application> dt. 12/10/2010.
- [17] A G Novitskii, V V Sudakov; An unwoven basalt-fibre material for the encasing of fibrous insulation : an alternative to glass cloth; *Refractories and Industrial Ceramics*; vol 45, no 4, 2004, pp 234 - 241.
- [18] www.sfmarina.com/basalt.pdf; dt. 14/12/2010; Breaking waves and breaking news introducing the unique reforcetech; reinforced concrete pontoon; Presentation given to the audience at Gothenburg Boatshow; February 2010; Lars G Odhe; SF Marina System – The Breakwater company.

- [19] R.V. Subramanian and H.F. Austin; Silane coupling agents in basaltreinforced polyester composites; International journal of adhesion and adhesives; Volume 1, Issue 1, July 1980, Pages 50-54.
- [20] http://www.npo-vulkan.com/index_en.php, 15/10/2010.
- [21] [http:// www.filtsep.com](http://www.filtsep.com); Basalt use in hot gas filtration; January/February 2005