



## A Simple Model for Cluster Efficiency

**Katic, I.; Højstrup, J.; Jensen, N.O.**

*Published in:*  
EWEC'86. Proceedings. Vol. 1

*Publication date:*  
1987

*Document Version*  
Publisher's PDF, also known as Version of record

[Link back to DTU Orbit](#)

*Citation (APA):*  
Katic, I., Højstrup, J., & Jensen, N. O. (1987). A Simple Model for Cluster Efficiency. In W. Palz, & E. Sesto (Eds.), *EWEC'86. Proceedings. Vol. 1* (pp. 407-410). A. Raguzzi.

---

### General rights

Copyright and moral rights for the publications made accessible in the public portal are retained by the authors and/or other copyright owners and it is a condition of accessing publications that users recognise and abide by the legal requirements associated with these rights.

- Users may download and print one copy of any publication from the public portal for the purpose of private study or research.
- You may not further distribute the material or use it for any profit-making activity or commercial gain
- You may freely distribute the URL identifying the publication in the public portal

If you believe that this document breaches copyright please contact us providing details, and we will remove access to the work immediately and investigate your claim.

A SIMPLE MODEL FOR CLUSTER EFFICIENCY

I.KATIĆ, J.HØJSTRUP, N.O.JENSEN

SUMMARY

A theoretical model, for the calculation of the output from wind farms, is described. The model takes into account the characteristics of the turbines, and is intended to be used for optimizing the cluster configuration for a given site, where the distribution of wind speeds and velocities are known. When compared to similar, more sophisticated models, the results are generally in agreement. Full-scale measurements of wake interactions between the two Nibe turbines are presented and the results discussed. Model calculations, carried out for the Nibe machines, show the importance of the increased turbulent mixing downstream of a turbine.

1. INTRODUCTION

A wind turbine extracts energy from the wind and consequently retards the wind field behind the turbine. When we get sufficiently far downstream, the wind speed will have returned to its original value. Another turbine positioned in the wake of the first one will produce less energy for a given free-stream wind speed. An example of this is illustrated in Fig. 1. This shows measured power curves for the Nibe A-turbine in undisturbed flow and with the B-turbine running upstream at a distance of five rotor diameters. Obviously, the power reduction is significant and strongly dependent on the wind direction. When planning clusters of wind turbines this power reduction must be accounted for in order to be able to estimate the yearly production for the different cluster configurations possible at a given site. Several factors must be included if the power reduction for a cluster is to be calculated. These are:

- distribution of wind speed and direction
- characteristics of the wind turbines
- characteristics of the wake of the turbines.

Most previous investigations of the power reduction for different cluster configurations neglect the influence of topography and prevailing wind directions as well as the turbine characteristics.

I.Katić, J.Højstrup, N.O.Jensen  
Department of Meteorology and Wind Energy  
Risø National Laboratory  
DK-4000 Roskilde  
DENMARK

However, they use detailed and rather complicated descriptions for the wake profile. Hence, they are more suitable for theoretical studies than for actual planning purposes with real turbines.

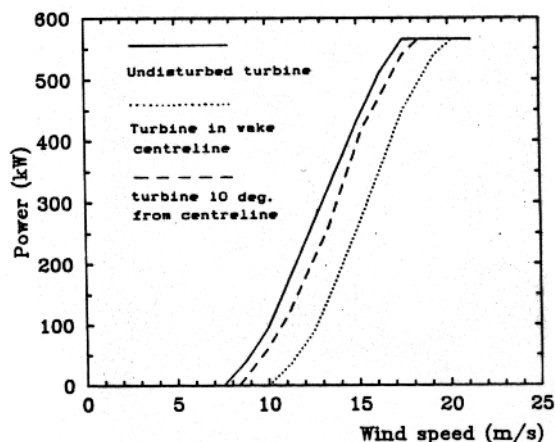

Nibe wake: Power reduction for A turbine

Fig. 1. Output versus wind-speed curve for the Nibe A-turbine when operating in wake of the B-turbine.

2. DESCRIPTION OF MODEL

The model presented here is a further developed version of a wake decay model proposed by N.O.Jensen [1]. Like most other models for wind farm calculation, it is based on the description of a single wake, in terms of an initial velocity deficit, and a wake decay coefficient. However, it differs from most similar models in the following ways:

- 1) The wake velocity profile is described in a very idealized way, by letting the wind velocity be constant inside the wake.
- 2) The actual characteristics of the turbines in the farm can be incorporated in the model, thus the different behaviour of stall- and pitch-regulated machines can be modelled.

3) In combination with the wind atlas method, the model can estimate the average yearly output of a wind farm, if a sufficiently detailed map of the area around the farm is available, and if the frequency distribution of the wind in eight direction sectors is known.

) The program can be run on a personal computer with a reasonable execution time.

### 2.1 Wake description

The wake behind a turbine is assumed to have a start diameter equal to the turbine diameter, and to spread linearly as a function of downwind distance. This simplification means that the wake velocity cannot be found very accurately at all downwind positions, but by adjusting the spread angle to fit data at distances larger than about four diameters, only the calculation of the near-wake zone will involve large errors. As wind turbines are seldom put closer together than this distance, it is not necessary to make accurate calculations here.

Inside the wake the velocity is considered constant, instead of using the commonly seen Gaussian distribution. This simplification is made because the aim of the model is to give an estimate of the energy content in the wind field seen by the downwind turbines, rather than to describe the velocity field accurately.

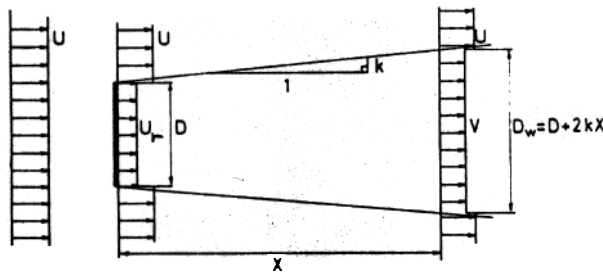

Fig. 2. Schematic view of wake description

With symbols defined in Fig. 2, a balance of momentum gives:

$$D^2 U_r + (D_w^2 - D^2) U = D_w^2 V$$

The wake velocity is found by the expression

$$V/U = 1 - 2a / (1 + 2kX/D)^2$$

a is defined as the initial velocity deficit  $1 - U_r/U$  but can also be expressed as

$$a = (1 - \sqrt{1 - C_t})/2$$

where  $C_t$  is the thrust coefficient of the turbine. Hence, the velocity deficit of the wake at a given position X is:

$$1 - V/U = (1 - \sqrt{1 - C_t}) / (1 + 2kX/D)^2$$

The problem of interacting wakes is solved by assuming the kinetic energy deficit of a mixed wake to be equal to the sum of the energy deficits for each wake at the calculated downwind position.

The resulting velocity by summation of two wakes is thus found by:

$$(1 - V/U)^2 = (1 - V_1/U)^2 + (1 - V_2/U)^2$$

Here,  $V_1$  and  $V_2$  represent the two original wake velocities.

Because the velocity deficits are squared, the total velocity deficit in the wake from a line, or from several rows of turbines, will quickly reach an equilibrium level, typically after 3-4 turbines or rows. This seems to be in good agreement with wind tunnel results [2]. The same formula is used to calculate the ground effect by placing an image wind turbine beneath the real turbine.

Because the thrust coefficient of a turbine normally is dependent on the wind speed, the initial velocity deficit will also be, and thus the calculated relative velocity deficit will only be valid for one wind speed. Together with the power versus wind speed characteristics, it means that the farm efficiency can be totally different for different wind speeds. For example, if the speed after the first row of turbines is reduced to below the cut-in speed, the efficiency is close to zero. In contrast, for a wind speed higher than the rated speed, the efficiency can exceed one if the power curve of a single turbine has a negative slope after the rated speed. When designing wind farms it is therefore important to estimate the occurrence of the whole range of operating wind speeds and directions.

The method of calculation for a wind farm with the Risø method can be divided into the following steps.

- 1) The type of wind turbine is chosen, and radius, hub height, power and thrust curves are given as data for the program.
- 2) The geometry of the cluster is given in terms of coordinates for each turbine. It is possible to align the coordinate system along the main axis of the cluster and later to turn it into the required geographical orientation.
- 3) Now a preliminary calculation can be made for different wind speeds and directions, to assure that the wake interaction does not give rise to an unacceptably small efficiency for the cluster.
- 4) Parameters for the Weibull distribution of the site are given for each 45-degree direction sector together with the frequency of the wind occurring from that sector.
- 5) The annual average output is calculated by stepping through all wind speeds and directions. This is the most time-consuming calculation; on an Olivetti M24 PC with math-processor it takes about 15 minutes to calculate a cluster of 25 turbines.

As an output from the last calculation comes the production of a turbine at a given site if there were not wake interaction, and the production from an average turbine in the park, with wakes taken into account. The ratio between these is called the farm efficiency.

### 3. COMPARISON WITH OTHER MODELS

Some comparisons have been made, using test examples calculated by more sophisticated models from TNO, Holland and CEEB, Great Britain [3].

Although there are some differences at

certain wind directions, the overall results are the same. The differences can be explained mainly due to the simple wake profile of the Risø model, which gives an on-off like characteristic behaviour of the wake effect when the wind direction changes.

When comparing the models it is a problem how to determine the wake decay constant, which is influenced by a lot of factors, such as ambient turbulence level, turbine-induced turbulence, and atmospheric stability. However, the overall output for typical wind farm calculations is relatively insensitive to minor changes of the decay constant. This is because a small constant gives a large power reduction, but only in a narrow zone while a large constant gives a smaller reduction in a wider zone. The result is sensitive to the value chosen for calculation in specific directions only; when all directions are considered, the importance of the wake decay constant vanishes.

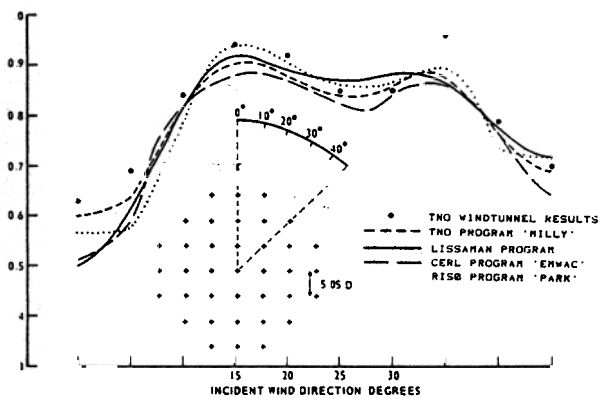

Fig. 3. Comparison of the Risø model with others

#### 4. NIBE WAKE MEASUREMENTS

Data from the Nibe site have been collected to investigate the behaviour of the wake from the two 630-kW machines.

The data used here were obtained from a data set of approximately 10,000 one-minute averages taken in wake interaction situations at Nibe during the first half of 1986. Instrumentation and site were described in [4]. Figure 4 shows the arrangement of masts and turbines; however, mast 0 does not exist but is shown to illustrate the free boundary-layer velocity profile.

The data are selected with both turbines running, and the direction sector is  $\pm 5$  degrees from the line connecting the turbines.

The incoming wind speed is calculated by using the B-turbine as the anemometer, and letting the speed at hub height be representative. From this speed the whole profile is calculated. The wind speed iso-curves shown on the figure are only a rough estimate of the actual length section of the wake, because only a few points are measured per curve. It is interesting to note that the wakes from the two machines seem to be almost similar, even though the incoming wind speed on the A-turbine is much smaller than on the B-turbine. This indicates that the wake decay constant is increasing after the A-machine because of increased mixing due to a higher turbulence level.

The problem of increased turbulence downstream of a turbine is also illustrated in Fig. 5, which shows the velocity profiles at the four masts, together with calculated wind speeds at hub height.

If the same decay constant of 0.075 is used before and after the A-turbine, it seems that the mixing rate after the A-machine is underestimated, a constant of 0.11 fits much better here. However, the measurements are all done within 4 diameters from the turbines, and may therefore not be expected to fit the model very precisely.

Also, the A-turbine differs from the B-turbine by having stays on the rotor, which may induce some additional turbulence.

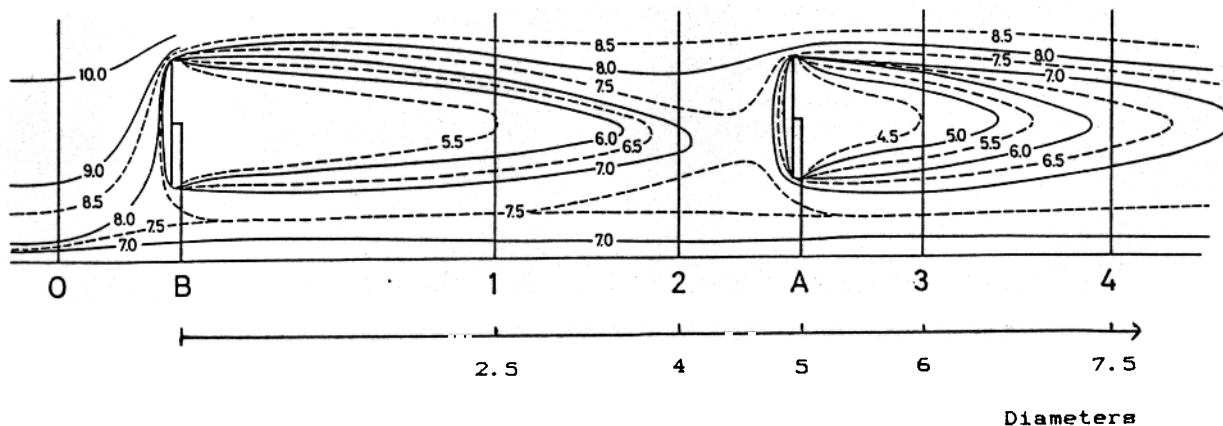

Fig. 4. Iso-curves for wind speed in the wake of Nibe turbines

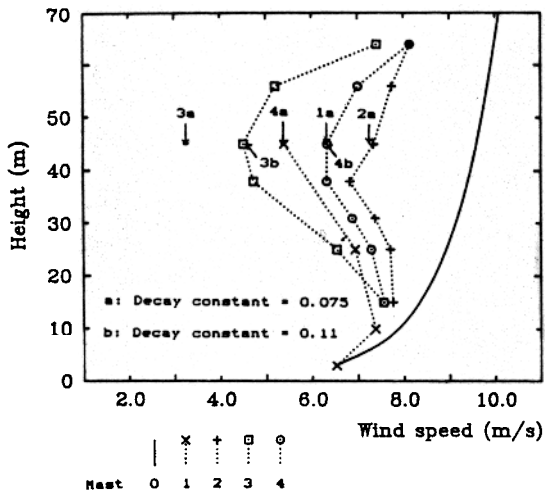

Fig. 5. Measured velocity profiles and computed centre-line velocities

### 5. CONCLUSION

Using the model presented for wind farm calculations, good agreement is found with more complete models and with the few measurements available.

Until more full-scale measurements are carried out it is difficult to conclude anything about the accuracy of the computations.

Since so many aspects concerning wakes need to be clarified, it does not seem worthwhile to extend the model at present.

The PC-program developed is believed to be a practical tool for wind farm developers as long as one is only interested in the mean energy production. Other aspects, like additional loads due to increased turbulence, or economics, must be treated separately.

### ACKNOWLEDGEMENTS

The data from Nibe used here has arisen from a collaborative project (described in [4]) with, and is used with the permission of the Central Electricity Generating Board, U.K., who received financial assistance for the enhancement of the Nibe measuring system from the Commission of the European Communities, the Department of Energy, U.K. and the National Board for Science and Technology, Ireland.

### BIBLIOGRAPHY

- [1] N.O.Jensen "A Note on Wind Generator Interaction" - Risø - 1983
- [2] S.A.Jensen and P.Ingham "Lokale læiveres indflydelse pa vindmøllers energiproduktion" - Danish Maritime Institute - 1984
- [3] J.F.Ainslie "Comparison of Wake Models for Computing Interactive Effects Between Wind Turbines" - CEBG - 1982
- [4] D.T.Swift-Hook, J.Højstrup, D.N.McIntosh, D.J.Milborrow, and G.J.Taylor "Nibe Wake Measurements project in Denmark" - In Proceedings of EWEC'84 - ed. W.Palz - published by H.S.Stephens and Associates - 1985