

In presenting the dissertation as a partial fulfillment of the requirements for an advanced degree from the Georgia Institute of Technology, I agree that the Library of the Institute shall make it available for inspection and circulation in accordance with its regulations governing materials of this type. I agree that permission to copy from, or to publish from, this dissertation may be granted by the professor under whose direction it was written, or, in his absence, by the Dean of the Graduate Division when such copying or publication is solely for scholarly purposes and does not involve potential financial gain. It is understood that any copying from, or publication of, this dissertation which involves potential financial gain will not be allowed without written permission.

A handwritten signature in dark ink, consisting of a series of loops and a long horizontal stroke at the end, positioned above a solid horizontal line.

7/25/68

A SIMULATION MODEL OF THE SOUTHERN
PULPWOOD PROCUREMENT SYSTEM

A THESIS

Presented to

The Faculty of the Graduate Division

by

Leslie Waits Rue

In Partial Fulfillment

of the Requirements for the Degree

Master of Science in Industrial Engineering

Georgia Institute of Technology

November, 1968

A SIMULATION MODEL OF THE SOUTHERN
PULPWOOD PROCUREMENT SYSTEM

Approved:

[Handwritten signature]

Chairman

[Handwritten signature]

[Handwritten signature]

Date approved by Chairman: Nov. 20, 1968

ACKNOWLEDGMENTS

The author wishes to express his sincere appreciation for the valuable criticism, guidance, and encouragement given by Mr. Nelson K. Rogers who acted as thesis advisor. Special thanks is given Dr. Joseph Krol and Professor Cecil Johnson for their service on the Reading Committee.

Thanks are also due to the Southern Executives Association for their financial support which made this research possible.

A special debt is owed to my wife who has offered continuous encouragement throughout this research.

TABLE OF CONTENTS

	Page
ACKNOWLEDGMENTS	ii
LIST OF TABLES	v
LIST OF ILLUSTRATIONS	vi
SUMMARY	vii
Chapter	
I. INTRODUCTION	1
II. LITERATURE SURVEY	6
A Previous Attempt to Simulate the System	
Pulpwood Procurement Systems	
Changes in Pulpwood Procurement Systems	
Simulation Literature	
Conclusions of Literature Survey	
III. PROCEDURE	14
Plan of Attack	
Scope of the Model	
The Modeling Language	
Data for the Model	
IV. MODEL FORMULATION	17
General Description	
Initial Conditions	
Driving Force of the Model	
Mill Procurement Sector	
Independent Woodyards Sector	
Dealer Woodyards Sector	
Company Woodyards Sector	
Independent Harvesters Sector	
Dealer Harvesters Sector	
Company Harvesters Sector	

TABLE OF CONTENTS (Continued)

Chapter	Page
V. MODEL EXPERIMENTS	71
Driving Functions Used	
Parameter Combinations Tested	
Results of Experiments	
VI. CONCLUSIONS AND RECOMMENDATIONS.	85
APPENDIX	88
BIBLIOGRAPHY.	94

LIST OF TABLES

Table		Page
1.	Parameter Values Associated With Run Numbers	75
2.	Significant Results of Zero Consumption Change Experiments	76
3.	Significant Results of Experimentation With Ramp Function	78
4.	Significant Results of Experimentation With Step Function.	79
5.	Significant Results of Experimentation With Sine Function.	82

LIST OF ILLUSTRATIONS

Figure		Page
1.	Basic Flows of the Model	18
2.	Seasonal Inventory Change	23
3.	Flow Diagram of Mill Procurement Sector.	29
4.	Flow Diagram of Independent Woodyards Sector	35
5.	Flow Diagram of Dealer Woodyards Sector.	42
6.	Flow Diagram of Company Woodyards Sector	50
7.	Flow Diagram of Independent Harvesters Sector	57
8.	Flow Diagram of Dealer Harvesters Sector	64
9.	Flow Diagram of Company Harvesters Sector	70

SUMMARY

This research was undertaken in conjunction with a research grant awarded to the School of Industrial Engineering at Georgia Institute of Technology by the Southern Executives Association to study the systems and transportation aspects of pulpwood harvesting. The objective of this research was to formulate a scientific basis for determining whether or not the present harvesting system in the South, which is composed largely of independent producers, should be continued over the long run.

The philosophy and techniques of industrial dynamics were applied in this research. The DYNAMO computer simulation language was used to build a mathematical model of the actual system. Simulation experiments on the model led to the formulation of the decision basis sought.

The results of the experiments performed on the model led to the decision that the overall present pulpwood harvesting system must move in the direction of larger company operated harvesting systems. A system composed of large company harvesting operations reacts much faster to changes in mill consumption rates. This system also has a much greater capability for increasing productivity per crew than does the present system.

Because average parameter values were used in this model of the general case, it is strongly recommended that individual mills experiment with this model using data representative of their current procurement system. The results obtained will provide information pertaining to the response capabilities of the

procurement system of that particular mill.

The capabilities of the model are much greater than were exhibited in this research. The model can be used to experiment with almost any phase of the present procurement system.

CHAPTER I

INTRODUCTION

The demand for paper and woodpulp products has increased greatly during the past several decades. In 1964, Chidester (1) reported that each American consumed 450 pounds of paper per year -- more than double the consumption in 1940 and five times the consumption of 1920. Chidester further stated that annual consumption is increasing at a rate of better than three per cent a year. Beggs (2) predicted that the American consumption of all grades of paper and paperboard will increase from about 42 million tons in 1964 to about 64 million tons in 1975. This would represent an annual average increase in consumption of 3.9 per cent as compared with a 3.6 per cent increase since 1953.

Likewise, over this same period of time, the growth of the pulpwood industry in the South has been spectacular. In 1920, there were 24 pulp mills operating in the South with an average mill production capacity of 41 tons of pulp per day (3). In 1966, 87 mills were in operation and average mill capacity had increased to approximately 744 tons per day (4). In 1920, the South's share of the nation's total pulp production was six per cent. By the end of 1966, the combined capacity of southern pulp mills represented fifty-eight per cent of total national production capacity (4). Hodges (5) predicted that the national pulpwood production will double by the year 2000 with the South accounting for more than 60 per cent of the total production.

Thus, it can be concluded that while the South is currently accomplishing the large-scale task of producing and collecting wood for pulping, the task will grow substantially greater in the future.

Accompanying this industry-wide growth have been improved harvesting methods. Provision of the raw material and its harvesting operations have evolved in the same general pattern as for agricultural products. In the early stages, manual labor with hand tools and animal power of some type predominated. These early harvesting methods were gradually phased out by light machinery and small power tools. Heavy equipment is now replacing much of the light machinery and small power tools.

However, the organization for acquiring pulpwood in the South has changed very little since its beginning. In the early 1920's, pulpwood companies began appointing local merchants as wood buyers (6, p. 3). These merchants purchased wood from local producers and transported it to the mill. In 1961, Britt (7) estimated that eighty-eight per cent of all pulpwood procurement in the United States was harvested by independent producers and that sixty-three per cent was routed to a mill through a woodyard dealer. These percentages are possibly even higher for Southern pulpwood procurement systems today. In 1963, Hamilton stated, "In the Southeast, paper companies do not harvest wood themselves, not even on company lands. Instead, an elaborate, although apparently efficient, system of wood brokers (dealers) and contractors (producers) meets the needs of the area." Basically, this latter contractor is the small-scale independent producer using a chain-saw and stake truck system.

Unfortunately, pulpwood harvesting is only a part-time occupation for many of the independent producers. Many small farmer-landowners on whom the industry depends for the major portion of its stumpage supply harvest pulpwood during the winter because they are engaged with farming activities during the summer (8). Also, many of these independent producers prefer not to sell pulpwood except when they themselves are able to supervise the cutting. As a result, many independent producers often wait until the winter, when they have more time, to cut and sell their wood. Thus, because pulpwood harvesting is not a full-time occupation with many independent producers, the individual producer does not produce at a rate which can be accurately predicted on an annual basis.

As is the case with most other industries, further technological progress is essential to the pulpwood industry if the industry is to sustain and increase economic growth in today's dynamic economy. Within the circle of technology is the circle of mechanization, a specific kind of change in production techniques.

Today, mechanized harvesting is in the late stages of a prolonged infancy. Most procurement environments have favored mechanization to make the job easier but have severely limited additional mechanization to make the job more productive (9). Most of the machinery used by producers to make the job easier has had several things in common: It has cost little; it was easy to operate and repair; it could be incorporated into existing operations with little adjustment; and it required little change in wood handling procedures at consolidation yards.

Most machinery capable of greatly increasing productivity also has certain

things in common: It is expensive; it is complicated to operate and repair; it usually requires complete reorganization of operations; and it may require changes in wood handling at consolidation yards (9).

It is readily evident that the machinery necessary to greatly increase productivity has been slow in arriving because it cannot be acquired, implemented, or adapted from existing systems by the independent producer. The average independent producer cannot meet any of the criteria required to own and operate this type machinery (9).

Thus, the industry has reached the critical point at which a decision must be made -- to continue the present system, composed largely of independent producers, and thereby sacrifice gains in productivity per producer, or to phase out the independent producer and move toward a system composed largely of company and non-independent dealer* producers.

The objective of this research is to formulate a scientific basis for making the above decision. The problem will be approached by constructing a mathematical model of the present system. Because the pulpwood procurement system, even in the single mill environment, is a large-scale and complex system, a computer simulation technique will be used to model the system. Industrial dynamics, a specific simulation technique, lends itself particularly well to this type system and, therefore, will be utilized in this research.

Once the model has properly been constructed, the variables having major

- - - - -

* A dealer is referred to as any non-company producers or consolidators who have contractual obligation of any sort with the mill.

impact on the system performance can be identified. Having identified these variables, the system can be redesigned using larger percentages of company producers. The outputs of each type of system can then be quantitatively compared. A basis for the decision ultimately sought in this research will emerge from the above comparisons.

In 1967 a research grant was awarded by the Southern Executives Association to Georgia Institute of Technology, School of Industrial Engineering, to study the "Systems Aspects of Harvesting and Transportation of Pulpwood." This research was formulated in coordination with Mr. N. K. Rogers, Project Director of the research group.

Although the industry is aware of the problem being investigated herein, very limited research has been performed in this area and certainly no final answers have been reached.

It is anticipated that this research effort will give management in the pulpwood industry significant insight as to which direction their industry should move in the coming years.

CHAPTER II

LITERATURE SURVEY

A search of literature shows that although much has been written about the various factors within the pulpwood procurement system, only one effort, by the Battelle Memorial Institute (10), has been made to relate them to each other in a quantitative model. Therefore, after first examining the Battelle effort mentioned above, the approach taken in this literature search was to investigate the basic types of pulpwood procurement systems and the changes currently taking place in these systems. Additional literature research was performed to aid in the selection of the technique to be used in approaching the problem.

A Previous Attempt to Simulate the System

In 1964, Battelle Memorial Institute, under sponsorship of the American Pulpwood Association, performed a research project (10) designed to fulfill the following broad objectives:

1. To define and improve the technology of pulpwood harvesting technology in the Southeast.
2. To make the flow of wood through the system more uniform.

The Battelle study utilized the industrial dynamics technique to model the basic procurement system in the Southeast. However, the Battelle model was limited to harvesting by independent producers and handling by independent

woodyards. Company and dealer woodyards and producers were completely eliminated from the model. The Battelle model showed that the major cause of the wood-shortage problem was the lag required by the wood-production system before it could respond to required changes in mill consumption rates (11). It was also noted that producers and woodyard operators were extremely reluctant to add to their production capacity. This reluctance to add to production capacity is basically a result of the following three factors: the relatively small scale of each operation, the risk associated with investing in extra capacity in the face of unsure future demand (6, p. 7) and the ambitions and goals of the producers (12). The Battelle model further showed that as long as wood orders continue to rise by ten per cent or more, producers will never "catch-up" with demand, and inventories will continue to fall until a wood shortage develops.

Battelle proposed a solution which involved removing the hauling function from the producers and assigning it to hauling specialists. Battelle reasoned that, because of their size, these hauling specialists would better be able to add extra trucks (the major cost of capacity acquisition) than the producers.

Although it did contribute significant information to this research, it is felt that the Battelle study was greatly over-simplified. This conclusion is based on the fact that only the independent woodyard-independent producer system was incorporated into the model.

Pulpwood Procurement Systems

As a result of the rapid growth of the paper industry, the pulpwood procurement system has grown in a haphazard manner, not by design but as a result of

the forces in the economic environment within which it exists.

Three systems of procuring pulpwood in the Southern states are outlined and described in the TAPPI Monograph Series No. 4 (13, p. 114). These systems are:

- (1) Woodyard-producer
- (2) Mill representative-producer
- (3) Company logging operations

The woodyard-producer system is basically the system described in the Battelle study and is the most widely used in the South (13, p. 114). Under this system, the woodyard operator contracts with the mill to ship an agreed volume of wood from his specified and protected territory. It is the woodyard operator's responsibility to organize wood production in his territory. This may even include financial aid by the woodyard operator to his producers for the purpose of purchasing equipment. Mills frequently maintain field expeditors who keep in contact with the woodyards.

The mill representative-producer system is similar in that the mills place resident supervisors in an area covering several counties. It is their function to develop wood production by contact with the woodland owners and producers. Advantages of this system are closer contact with the producers and very often better control over the flow of wood. The main disadvantage of the system is the large number of producers with whom the mill representative must maintain contact (6, p. 8).

The company logging operations system deals with the complete purchase

and logging by mill payroll personnel. Until recently, very little wood was procured in this manner, but the increased demand for pulpwood, the need to procure pulpwood from less favorable areas, the advantages of company crews logging fee lands, and interfering governmental regulations and restrictions have prompted several pulp companies to implement their purchased wood procurement with company operations (13, p. 119).

Company operations are the most reliable source of wood supply, but tend to be more expensive than either the woodyard-producer system or the mill representative-producer system (6, p. 8).

Albin (14) reported an extremely successful mill representative-producer system where wood quality was of the utmost importance. This system has consistently produced an adequate supply of high quality wood at a competitive price.

Evans (15) reported a large scale company logging operation where a large volume of wood was required and large company-owned forest resources were located close to the mill.

In reality, most mills do not receive their pulpwood through any one of the above procurement systems alone, but through one or more combinations of these systems.

Changes in Pulpwood Procurement Systems

Mechanization has brought many changes in the pulpwood procurement system. Jeffords (8) has stated, "The biggest advance in the trend of mechanization has been the development and growth of field woodyards." Although woodyards are not new to the South, mechanization has aided their widespread growth.

Woodyards are referred to here, may be operated by independents, dealers, or companies.

Jeffords also investigated the advantages of field woodyards to both the producer and the mill.

Silversides (16) stated:

One effect of mechanization in the forest will be the change from relatively free men working for themselves with comparatively little supervision and paid according to their output, to wage earners. Free men normally do not have the capital and are unable to earn enough to invest in large, costly machinery for themselves.

Silversides further described the extensive effects of mechanization on the financial and economic structure of the pulpwood industry.

In a highly mechanized operation, total cost is predominantly made up of the cost of capital equipment (6, p. 10). This is opposed to the labor intensive operation where labor costs make up the largest part of the total cost. The result of the mechanized system is rigidity in cost per unit related to the capacity of the mechanized system. As efficiency and productivity are stressed, the degree of mechanization is increased. Likewise as capital investments are increased, there is a trend toward the desire for maximum utilization (6, p. 10).

Referring to the change in the type of producers, Hodges (5) stated, "Out of this change is emerging a new type of producer in the South. A well-equipped, articulate businessman, he is efficient and dependable. He knows his job and gets it done."

Because of the large investments required, the independent producers of pulpwood are incapable of mechanization to any great degree. However, attempts

are being made to aid the independent producer. Lee (9) stated, "One company is seeking to promote mechanization by offering incentives to producers willing to invest in harvesting equipment."

Some other trends in woodhandling from woods to pulpmill were summarized in Dyer (17) generally as follows:

1. The total cost concept -- the idea that woodhandling from stump to pulping equipment should be considered as one realm.
2. Accelerated and even flow of wood to the mill all-year round. Large blocks of inventory need to be eliminated.
3. Chipped sawmill residue utilization will grow until transportation costs from sawmills to consuming pulp mills render this method uneconomical.
4. Pulpwood production is trending to eight foot length wood, peeled or rough, because of economies in handling by truck.
5. One of the highest cost factors in wood preparation is the double handling of wood. Wherever possible it should be avoided.
6. Mechanized logging methods are forcing mills to search for new methods of measuring wood.
7. New pulping techniques may force greater species segregation which promotes higher costs.

Simulation Literature

Because the present pulpwood procurement system is an extremely complex system, a modeling approach was selected to pursue the problem.

Having decided to use a modeling approach, the task became one of choosing

a technique which matched the nature of the problem. The dynamic implications of the present pulpwood procurement system and its environment led this author to choose computer simulation as the tool to be used.

Naylor (18) gives a definition that involves the common concepts of the simulation technique:

Simulation is a numerical technique for conducting experiments on a digital computer, which involves certain types of mathematical and logical models that describe the behavior of a business or economic system (or some component thereof) over extended periods of real time.

The industrial dynamics technique of J. W. Forrester (19) is a method of simulation in which many varied factors can be related within a single framework. Forrester states (19), p. vii, "Industrial Dynamics is a way of studying the behavior of industrial systems to show how policies, decisions, structure, and delays are interrelated to influence growth and stability." Also the industrial dynamics model provides a framework for the design of an improved system and guiding policy. Jarmain (20) has demonstrated the usefulness of the technique by applying it to many varied and widespread problems. Packer (21) also used the industrial dynamics methodology in a large scale problem involving resource acquisition and corporate growth, a condition that is expected to predominate in the pulpwood industry for some time (6, p. 11).

Conclusions of Literature Survey

Very little research which treats the present pulpwood procurement system as a system has been conducted. The Battelle research project proved to be oversimplified.

All other research has been aimed at one or more specific elements of the system. However, these research projects have aided the "systems" researcher by preparing the industry for change.

Thus, it is felt that any justifiable results which emerge from this research will extend the current knowledge in this field and will be looked on favorably by the pulp and paper industry.

CHAPTER III

PROCEDURE

Plan of Attack

This research was carried out in a series of fairly distinct steps. The steps are outlined below:

(1) The problem was identified and system boundaries were established at the appropriate level for study.

(2) The factors believed to be of major importance within the system were isolated.

(3) A mathematical model corresponding to the conceived present system was formulated.

(4) System behavior was simulated through time. The behavior of the model was compared with behavior which seems reasonable for the present real world system. The model was altered wherever discrepancies appeared.

(5) The model was analyzed to determine which factors play the most important parts in determining the system behavior.

(6) The model was tested under different producer-mill relationships to determine which relationships would be most beneficial to the industry.

(7) The results of the model experiments were related to the real world system, and their implications were discussed.

Scope of the Model

Pulpwood flow is controlled by orders representing decisions based on information about inventories and demand (sales). Therefore, the model will include material (wood) and order flow networks. Since labor is of primary interest to this research, a producer crew flow network will also be included.

The Modeling Language

The DYNAMO digital computer language was used in modeling the system. The primary reason for the choice of DYNAMO was its natural adaptability to the industrial dynamics technique. DYNAMO also has the following advantages:

- (1) It requires no extensive computer programming experience.
- (2) Simple coded words can be used to represent variables.
- (3) It is easy to "debug" and analyze.
- (4) It provides for feedback characteristics.
- (5) It provides for system delays.
- (6) It provides for complex nonlinear relationships.
- (7) Results can be easily interpreted by a person who is unfamiliar with the language itself.
- (8) Great computational speed provides efficient and economical computer usage (22, p. 18).

Data for the Model

The data used in establishing the parameters of the model were collected primarily through appropriate literature searches. The delays and constants used

were decided upon through consultation with Mr. Rogers and other members of the research group.

CHAPTER IV

MODEL FORMULATION

The quantitative simulation model written in DYNAMO will be presented in this chapter. Chapters six through nine of Jay W. Forrester's Industrial Dynamics (19) and sections 1.1 through 1.4 in chapter one of Alexander L. Pugh's Dynamo User's Manual (23) are suggested as preparatory material for the reader who is unfamiliar with the DYNAMO language.

General Description

Because the solution time interval must be at least one-half as short as the shortest delay in the model, the solution time interval "DT" is defined in the model as one-tenth of a week. The values of plotted variables were shown every two weeks. Each experiment was run for a period of two years.

The model is structured in three general sectors: a mill sector, a wood-yard sector, and a harvester* sector. The woodyard and harvester sectors are each broken down into three separate sectors, distinguishable by type of operator: independent, dealer, or company. Thus, the complete model is basically composed of seven sectors. Figure 1 illustrates the basic information and wood flows through the aggregate system. The arrows pointing down represent information flows and the arrows pointing up represent wood flows.

- - - - -

* Harvester is used in this paper as synonymous with the industry term "producer."

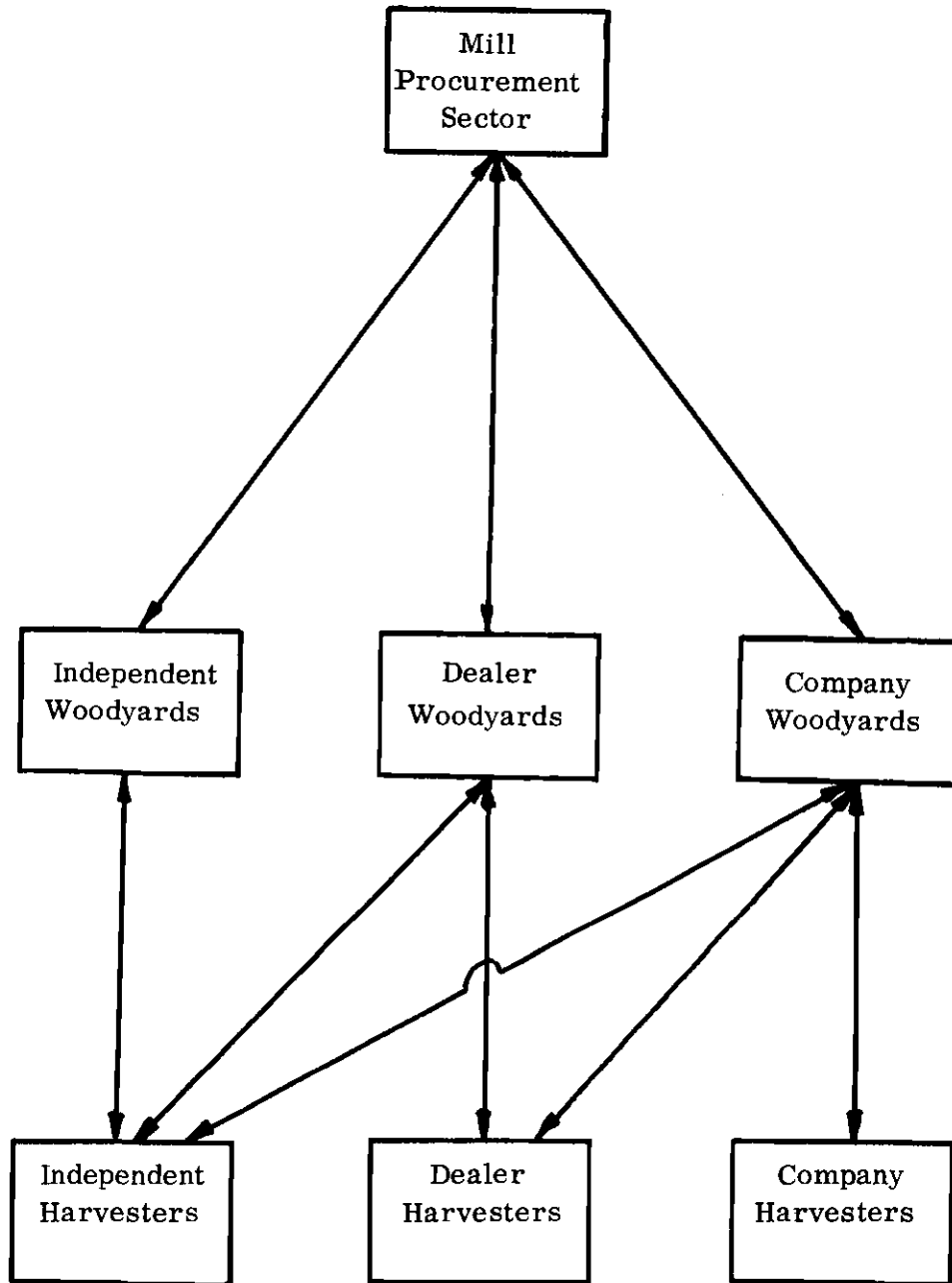

Figure 1. Basic Information and Wood Flows of the Model.

Each of the seven sectors will be described separately. The equations will be explained, and accompanied by a flow diagram for each sector.

Initial Conditions

It should be pointed out that all initial condition equations are defined in order to start the system in equilibrium, whether or not the system turns out to be stable or not. If the equilibrium point is unstable, any disturbance will initiate a growing departure from the initial conditions. The initial values have been stated in terms of the external inputs and the parameters of the system so that it is possible to change the values of parameters in the equations without making it necessary to respecify initial-value equations.

Driving Force of the Model

Orders sent from the mill procurement sector to the woodyards depend primarily on the rate at which wood is consumed at the mill. Therefore, the consumption by the mill acts as the basic driving force of the model.

The system reacts differently to different consumption fluctuations at the mill. Therefore, different consumption inputs will be experimented with to determine the different system responses. These experiments will be discussed in a later chapter.

Mill Procurement Sector

For the purposes of the model system, all orders for pulpwood originate

at the mill* procurement sector and all material flows terminate at this sector.

The unfilled orders at the mill are defined as a level that grows as a result of the orders received at the mill and diminishes as a result of the pulpwood shipments sent from the mill to the digesters (out of the system). Each time an order is shipped from the mill, this order is removed from the unfilled orders and filed. The orders received normal at the mill are equal to the rate of orders received times the minimum delay in handling orders.

**
 IL UOM. K=UOM. J+(DT)(ORM. JK-SSM. JK)
 12N UOM=(ORM)(DHM)
 12A UNM. K=(ORM. K)(DHM)

UOM - Unfilled Orders at Mill (cords)
 DT - Solution Time Interval (weeks)
 ORM - Orders Received at Mill (cords/week)
 SSM - Shipments Sent from Mill (cords/week)
 DHM - Minimum Delay in Handling at the Mill (weeks)
 UNM - Unfilled Orders Normal at the Mill (cords)

The actual inventory on hand at the mill procurement sector is defined as a level that grows as a result of inflowing wood and diminishes as a result of wood sent to the digesters (out of the system). Pulpwood flows into the mill procurement sector from three different sources: independent woodyards, dealer woodyards, and company woodyards.

- - - - -

* Mill will hereafter be used interchangeably with mill procurement sector.

** The numeric number denotes the form of the DYNAMO equation. The alphabetic designator denotes the type of DYNAMO equation. Note in particular that a N denotes an initial condition for the particular variable described.

52L IAM. KL=IAM. J+(DT)(PRCM. JK+PRDM. JK+PRIM. JK-SSM
 .JK)
 6N IAM=IDM

IAM - Inventory Actual at Mill (cords)
 DT - Solution Time Interval (weeks)
 PRCM - Pulp Received from Company Woodyards at Mill (cords/week)
 PROM - Pulp Received from Dealer Woodyards at Mill (cords/week)
 PRIM - Pulp Received from Independent Woodyards at Mill (cord/week)
 SSM - Shipments Sent from the Mill (cords/week)
 IDM - Inventory Desired at Mill (cords)

The mill would like to fill all its orders if possible; however, it cannot possibly ship more pulpwood to the digesters than it has in inventory at that particular time. To assure that the model does not try to ship more pulpwood than is presently in inventory, a clip function* is used. In determining the shipping rate tried, the unfilled orders are divided by the minimum delay in handling orders (the mill cannot possibly ship any faster than the minimum time that is required to process an order** and physically make the shipment to the digesters.) The minimum delay in handling an order was taken to be 1.4 weeks.

51R SSM. KL=CLIP(STM. K, NIM. K, NIM. K, STM. K)
 20A STM. K=UOM. K/DHM

- - - - -

* A clip function is interpreted in the following manner:

STM. K if NIM. K \geq STM. K
 SSM. KL=
 NIM. K if NIM. K < STM. K

SSM. KL equals STM. K if NIM. K is greater than or equal to STM. K. SSM. KL is equal to NIM. K if NIM. K is less than STM. K.

** Debark, chip, slash, etc.

20A NIM, $K=IAM \cdot K/DT$
 C DHM=1.4

SSM - Shipments Sent from the Mill (cords/week)
 STM - Shipping Rate Tried at the Mill
 NIM - Negative Inventory Limit Rate at Mill (cords/week)
 UOM - Unfilled Orders at Mill (cords)
 DHM - Minimum Delay in Handling at Mill (weeks)
 IAM - Inventory Actual at Mill (cords)
 DT - Solution Time Interval (weeks)

The inventory desired at the mill is defined as the sum of the inventory desired normal at the mill and the seasonal inventory change desired at the mill. The inventory desired normal at the mill is taken as that amount necessary to satisfy the mill consumption for two weeks. Because of labor fluctuations and varying weather conditions, the mill is forced to build up inventories accordingly, and thus try to prevent seasonal wood shortages. The seasonal inventory change^{*} is represented by a sine function and is shown, in graphical form, in Figure 2. The high point on the curve occurs just after winter and the low point occurs just after summer. Research has revealed this seasonal inventory change to be tantamount to changes of ± 10 per cent in consumption (11). It should be pointed out that the accuracy of simulating this seasonal inventory change is not an important factor to the aggregate model. The important fact is to recognize some reasonable seasonal inventory change.

7A IDM, $K=IDNM \cdot K+SIC \cdot K$
 6N IDM=IDNM
 12A IDNM, $K=(ORM \cdot K)(AIM)$

* The effects of weather may also be incorporated into the seasonal inventory change.

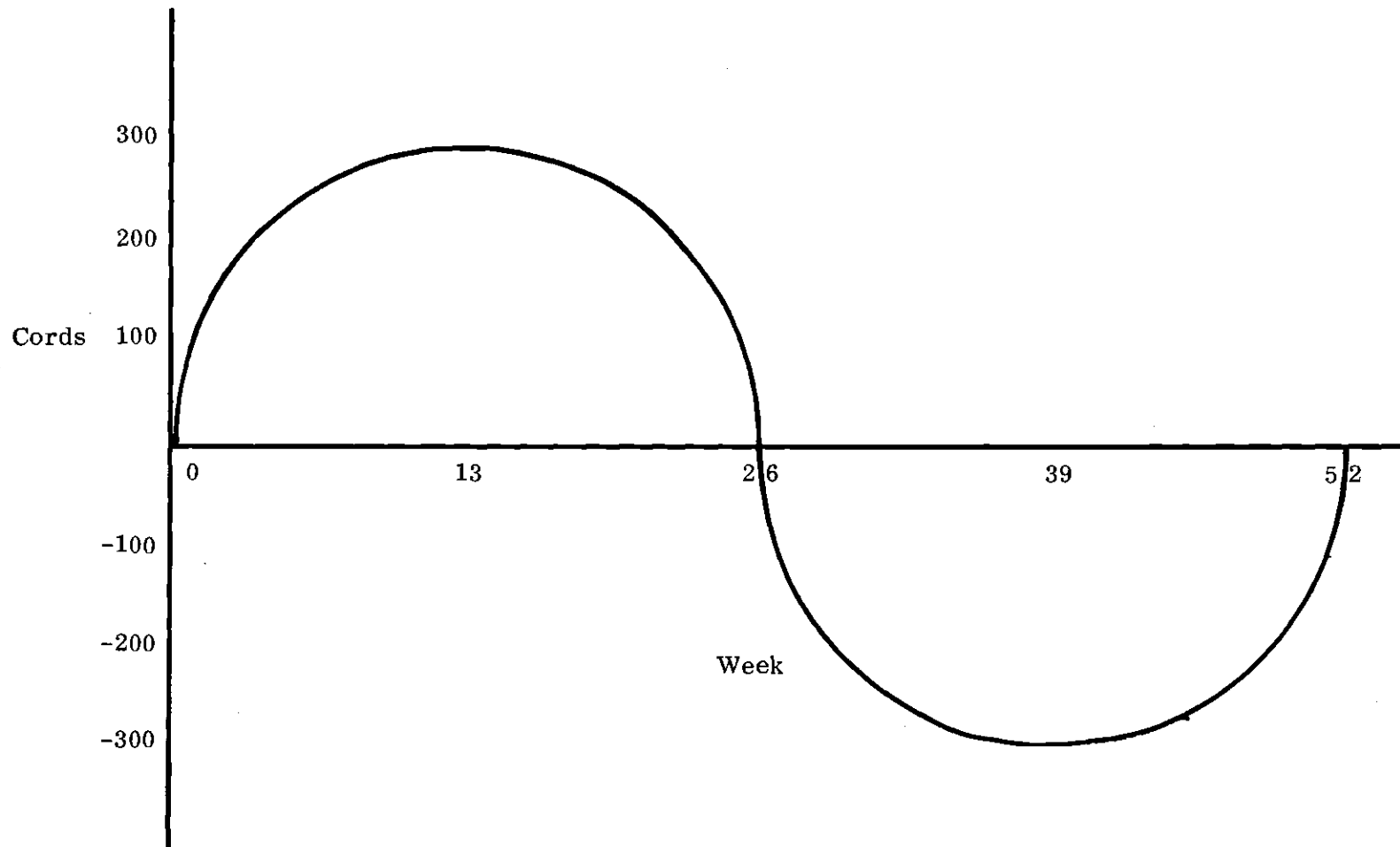

Figure 2. Seasonal Inventory Change.

C AIM=2
 31A SIC. $K=(310)\text{SIN}((2\text{PI})(\text{TIME. K})/52)$

IDM - Inventory Desired at Mill (cords)
 IDNM - Inventory Desired Normal at Mill (cords)
 SIC - Seasonal Inventory Change at Mill (cords)
 ORM - Orders Received at Mill (cords/week)
 AIM - Proportionality Constant Between Inventory and Orders
 Received at Mill (weeks)
 TIME - Calendar Time Measured in Weeks (automatically generated
 and available from DYNAMO compiler)

The order decision at the mill is based on the rate of orders received at the mill, the difference in the inventory desired and the inventory actual at the mill, and the difference in actual unfilled orders and unfilled orders normal at the mill. The mill orders enough wood to fill the orders received during that particular time interval, plus (minus) wood to balance, over a period of time, the difference in desired and actual inventories and the difference in actual unfilled and normal unfilled orders. The delay in adjusting the difference in inventories and unfilled orders was taken to be eight weeks.

25R ODM. $KL=ORM. JK+(1/DIM)(IDM. K-IAM. K+UOM. K-UNM. K)$
 C DIM-8

ODM - Order Decision at Mill (cords/week)
 ORM - Orders Received at Mill (cords/week)
 DIM - Delay in Adjusting Inventory at Mill (weeks)
 IDM - Inventory Desired at Mill (cords)
 IAM - Inventory Actual at Mill (cords)
 UOM - Unfilled Orders at the Mill (cords)
 UNM - Unfilled Orders Normal at the Mill (cords)

The total orders sent from the mill is an accumulation* of the order

- - - - -

* An accumulation and a level are defined to be one and the same.

decisions at the mill less the orders sent to the independent, dealer, and company woodyards during a certain time interval. The orders sent to the three respective woodyards will vary from mill to mill. Representative percentages have been used in this case. These representative percentages can easily be altered to better fit the data for any particular mill.

52L $TOSM. K = TOSM. J + (DT)(ODM. JK - OSIM. JK - OSDM. JK - OSCM. JK)$
 6N $TOSM = ORM$
 12R $OSIM. KL = (IWP)(TOSM. K)$
 C $IWP = .03$
 12R $OSDM. KL = (DWP)(TOSM. K)$
 C $DWP = .37$
 12R $OSCM. KL = (CWP)(TOSMIK)$
 C $CWP = .60$

TOSM - Total Orders Sent from Mill (cords)
 DT - Solution Time Interval (weeks)
 ODM - Order Decision at Mill (cords/week)
 OSIM - Orders Sent to Independent Woodyards from Mill (cords/week)
 OSDM - Orders Sent to Dealer Woodyards from Mill (cords/week)
 OSCM - Orders Sent to Company Woodyards from Mill (cords/week)
 IWP - Independent Woodyard Percentage of Total Orders Sent from Mill (1/weeks)
 DWP - Dealer Woodyard Percentage of Total Orders Sent from Mill (1/weeks)
 CWP - Company Woodyard Percentage of Total Orders Sent from Mill (1/weeks)

Once orders are sent to the respective woodyards, there is a communications delay in reaching each of these woodyards. Because these orders do not immediately reach their destination, a level of communication in process orders is formed for each of the different woodyards. A communication in process level is filled by the rate of orders sent to that particular woodyard and is depleted by the rate of requisitions (orders) actually received at that woodyard. The rate of

requisitions received at a particular woodyard is the output of a third-order delay function* which has the rate of orders sent to that particular woodyard as its input. The communication delay constant is less for the company woodyards than the independent and dealer woodyards. This is because the mill and the company woodyards have regular communication channels through which they communicate.

1L CPIM, K=CPIM, J+(DT)(OSIM, JK-RRIW, JK)
 13N CPIM=(TOSM)(IWP)(DCIM)
 1L CPDM, K=CPDM, J+(DT)(OSDM, JK-RRDW, JK)
 13N CPDM=(TOSM)(DWP)(DCDM)
 1L CPCM, K=CPCM, J+(DT)(OSCM, JK-RRCW, JK)
 13N CPCM=(TOSM)(CWP)(DCCM)
 39R RRIW, KL=DELAY3(OSIM, JK, DCIM)
 C DCIM=1
 39R RRDW, KL=DELAY3(OSDM, JK, DCDM)
 C DCDM=1
 39R RRCW, KL=DELAY3(OSCM, JK, DCCM)
 C DCCM=.5

CPIM - Communication in Process Orders to Independent Woodyards from Mill (cords)
 DT - Solution Time Interval (weeks)
 OSIM - Orders Sent to Independent Woodyards from Mill (cords/week)
 RRIW - Requisitions Received at Independent Woodyards from Mill (cords/week)
 TOSM - Total Orders Sent from Mill (cords)
 IWP - Independent Woodyard Percentage of Total Orders Sent from Mill (1/weeks)
 DCIM - Delay in Communications between Independent Woodyards and Mill (weeks)
 CPDM - Communication in Process Orders to Dealer Woodyards from Mill (cords)
 OSDM - Orders Sent to Dealer Woodyards from Mill
 RRDW - Requisitions Received at Dealer Woodyards from Mill (cords/week)
 DWP - Dealer Woodyard Percentage of Total Orders Sent from Mill (1/weeks)
 DCDM - Delay in Communications between Dealer Woodyards and Mill (weeks)

- - - - -

* A third-order delay function is explained in detail on page 90 of Forrester's Industrial Dynamics (19).

- CPCM - Communication in Process Orders to Company Woodyards from Mill (cords)
- OSCM - Orders Sent to Company Woodyards from Mill (cords/week)
- RRCW - Requisition Received at Company Woodyards from Mill (cords/week)
- CWP - Company Woodyard Percentage of Total Orders Sent from Mill (1/weeks)
- DCCM - Delay in Communications between Company Woodyards and Mill (weeks)

To fill the orders sent by the mill, there is wood flowing to the mill from the three different types of woodyards. These wood flows encounter transportation delays between the woodyards and the mill and therefore form an accumulation of pulpwood in transit between the woodyards and the mill. The transportation delays are represented by a third-order delay functions with the pulpwood sent from the woodyards as the inputs and pulpwood received at the mill as the outputs. In reality the delay constants will vary depending on the distance and mode of transportation. However, reasonable averages were taken as delay constants for the model. The transportation delay constant was taken to be greater for the independent woodyards. This is because the independent often has difficulty in securing railcars, barges, or longhaul trucks.

```

1L   PTIM. K=PTIM. J+(DT)(PSIW. JK- PRIM. JK)
13N  PTIM=(TOSM)(IWP)(DTIM)
1L   PTDM. K=PTDM. J+(DT)(PSDW. JK- PRDM. JK)
13N  PTDM=(TDSM)(DWP)(DTDM)
1L   PTCM. K=PTCM. J+(DT)(PSCW. JK- PRCM. JK)
13N  PTCM=(TOSM)(CWP)(DTCM)
39R  PRIM. KL=DE LAY3(PSIW. JK, DTIM)
C    DTIM=2
39R  PRDM. KL=DE LAY3(PSDW. JK, DTDM)
C    DTDM=1
39R  PRCM. KL=DE LAY3(PSCW. JK, DTCM)
C    DTCM=1

```

- PTIM - Pulpwood in Transit between Independent Woodyards and the Mill (cords)
- DT - Solution Time Interval (weeks)
- PSIW - Pulpwood Sent from Independent Woodyards to Mill (cords/week)
- PRIM - Pulpwood Received from Independent Woodyards at Mill (cords/week)
- TOSM - Total Orders Sent from Mill (cords)
- IWP - Independent Woodyard Percentage of Total Orders from Mill (1/weeks)
- DTIM - Delay in Transportation from Independent Woodyards to Mill (weeks)
- PTDM - Pulpwood in Transit between Dealer Woodyards and Mill (cords)
- PSDW - Pulpwood Sent from Dealer Woodyards to Mill (cords/week)
- PRDM - Pulpwood Received from Dealer Woodyards at Mill (cords/week)
- DWP - Dealer Woodyard Percentage of Total Orders Sent from Mill (1/weeks)
- DTDM - Delay in Transportation from Dealer Woodyards to Mill (weeks)
- PTCM - Pulpwood in Transit between Company Woodyards and Mill (cords)
- PSCW - Pulpwood Sent from Company Woodyards to Mill (cords/week)
- PRCM - Pulpwood Received from Company Woodyards at Mill (cords/week)
- CWP - Company Woodyard Percentage of Total Orders Sent from Mill (1/weeks)
- DTCM - Delay in Transportation from Company Woodyards to Mill (weeks)

A complete flow diagram of the mill procurement sector is shown in Figure 3.

Independent Woodyards Sector

The independent woodyards obtain wood from independent producers only.

In reality, there are exceptions to this case, but not enough to incorporate into the model. The exceptions are so small in number that they have a negligible effect on the aggregate model.

The unfilled orders at the independent woodyards are represented in the model by a level which grows as a result of the rate of requisitions received and diminishes as a result of wood sent to the mill. The unfilled orders normal are equal to the rate of orders received times the minimum delay in handling orders.

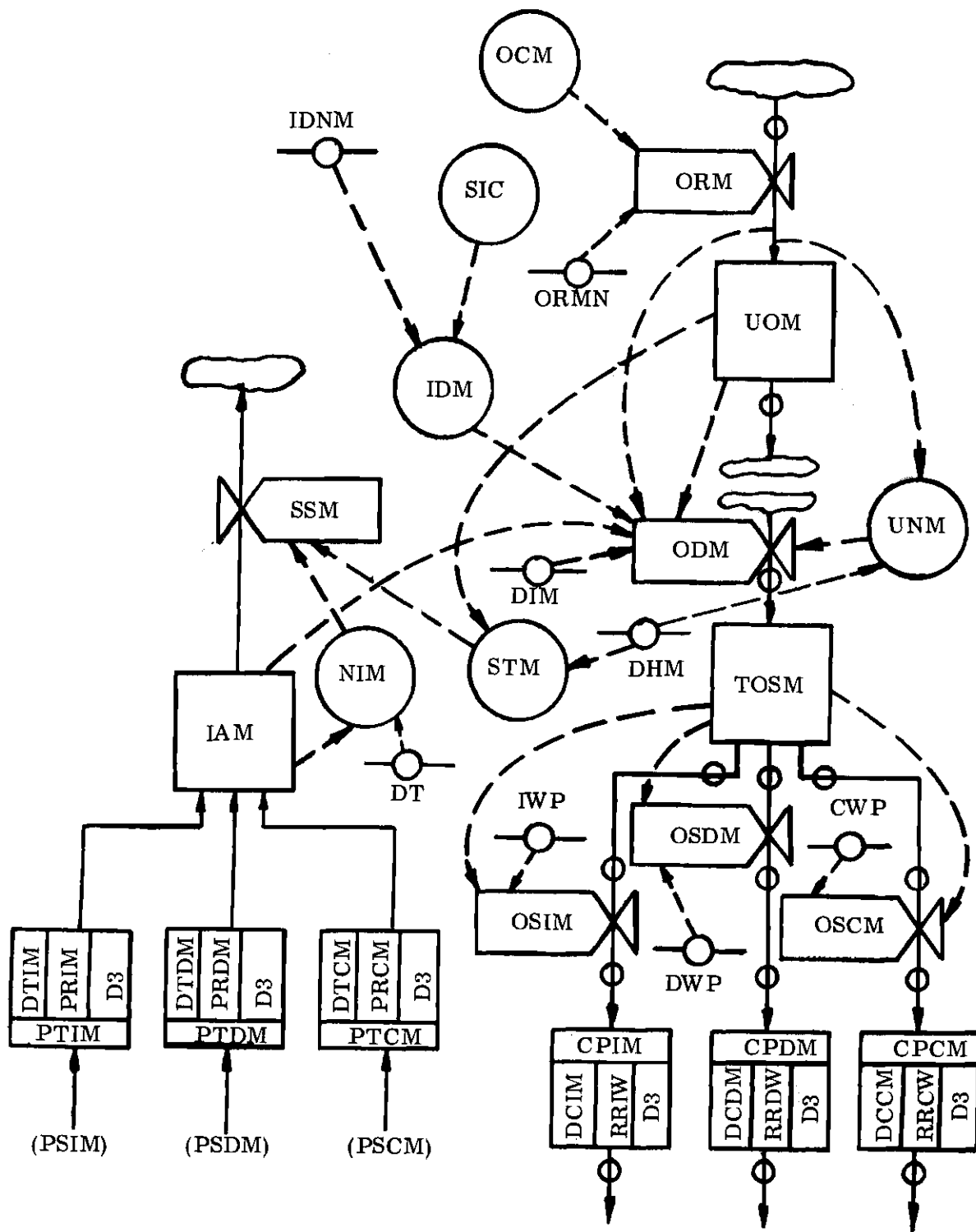

Figure 3. Flow Diagram of Mill Procurement Sector.

$$\begin{aligned}
 1L \quad & \text{UOIW. K} = \text{UOIW. J} + (\text{DT})(\text{RRIW. JK} - \text{PSIW. JK}) \\
 12N \quad & \text{UOIW} = (\text{RRIW})(\text{DHIW}) \\
 12A \quad & \text{UNIW. K} = (\text{RRIW. JK})(\text{DHIW})
 \end{aligned}$$

UOIW - Unfilled Orders and Independent Woodyards (cords)
 DT - Solution Time Interval (weeks)
 RRIW - Requisitions Received at Independent Woodyards from Mill (cords/week)
 PSIW - Pulpwood Sent from Independent Woodyards to Mill (cords/week)
 DHIW - Delay Due to Minimum Handling at Independent Woodyards (weeks)
 UNIW - Unfilled Orders Normal at Independent Woodyards (cords)

The inventory actual at the independent woodyards is represented as a level which increases by the rate of wood received from the independent harvesters and decreases by the rate of wood sent to the mill.

$$\begin{aligned}
 1L \quad & \text{IAIW. K} = \text{IAIW. J} + (\text{DT})(\text{PRIIW. JK} - \text{PSIW. JK}) \\
 6N \quad & \text{IAIW} = \text{IDIW}
 \end{aligned}$$

IAIW - Inventory Actual at Independent Woodyards (cords)
 DT - Solution Time Interval (weeks)
 PRIIW - Pulpwood Received from Independent Harvesters at Independent Woodyards (cords/week)
 PSIW - Pulpwood Sent from Independent Woodyards to Mill (cords/week)
 IDIW - Inventory Desired at Independent Woodyards (cords)

Ideally, the independent woodyards would like to fill all their orders in the minimum time. However, the woodyards can not possibly ship more wood than is in inventory at that same time period. Therefore, a clip function is used to prevent the model from shipping more wood than is present in inventory. The minimum order handling and shipping preparation time was taken as one week for the independent woodyards.

$$\begin{aligned}
 51R \quad & \text{PSIW. KL} = \text{CLIP}(\text{STIW. K}, \text{NIW. K}, \text{NIW. K}, \text{STIW. K}) \\
 20A \quad & \text{STIW. K} = \text{UOIW. K} / \text{DHIW}
 \end{aligned}$$

C DHIW=1
 20A NIIW. K=IAIW. K/DT

PSIW - Pulpwood Sent from Independent Woodyards to Mill (cords/week)
 STIW - Shipping Rate Tried at Independent Woodyards (cords/week)
 NIIW - Negative Inventory Limit Rate at Independent Woodyards
 (cords/week)
 UOIW - Unfilled Orders at Independent Woodyards (cords)
 DHIW - Minimum Delay in Handling at Independent Woodyard (weeks)
 IAIW - Inventory Actual at Independent Woodyard (cords)
 DT - Solution Time Interval (weeks)

The independent woodyards desire to have a certain supply of wood on hand at all times. However, they do not wish to have an excessive supply on hand because the wood will begin to rot if kept on the yard for any length of time. The amount of wood desired on hand is taken as .5 weeks supply.

12A IDIW. K=(AIW)(RRIW. K)
 C AIW=.5

IDIW - Inventory Desired at Independent Woodyards (cords)
 AIW - Proportionality Constant between Inventory Desired and Requisitions Received at Independent Woodyard (weeks)
 RRIW - Requisition Received at Independent Woodyards from Mill (cords/week)

The decision for the independent woodyards to order wood is based on the rate at which orders are being received, the difference between desired and actual inventories, and the difference between actual and normal unfilled orders. The woodyards want to order enough wood to fill the orders being received, and to balance, over a period of time, the difference between the inventory desired and the inventory actual and the difference between the actual unfilled orders and the normal unfilled orders. The period for adjusting the difference in desired and

actual inventories and actual and normal unfilled orders is taken as six weeks.

$$40R \quad ODIW.KL = RRIW.JK + (1/DIIW)(IDIW.K - IAIW.K + UOIW.K - UNIW.K)$$

$$C \quad DIIW = 6$$

- ODIW - Order Decision at Independent Woodyards (cords/week)
 RRIW - Requisition Received at Independent Woodyards from Mill (cords/week)
 DIIW - Delay in Adjusting Inventory at Independent Woodyards (weeks)
 IDIW - Inventory Desired at Independent Woodyards (cords)
 IAIW - Inventory Actual at Independent Woodyards (cords)
 UOIW - Unfilled Orders at Independent Woodyards (cords)
 UNIW - Unfilled Orders Normal at Independent Woodyards (cords)

Once the order decision has been made, there is a communications delay between the independent woodyards and the independent harvesters. The woodyards cannot always contact the harvesters when desired. This communications delay is represented in the model by a third-order delay function. The delay constant is taken to be one week. Because of the delay in communications, a level of communication in process orders from the independent woodyards to the independent harvesters is formed. The order decision rate at the independent woodyards serves as the input to the level and the rate of requisitions received from the independent woodyards at the independent harvester serves as the output. The communications delay is taken to be one week.

$$1L \quad CPIW.K = CPIW.J + (DT)(ODIW.JK - RRIIH.JK)$$

$$12N \quad CPIW = (RRIW)(DCIW)$$

$$39R \quad RRIIH.KL = DELAY3(ODIW.JK, DCIW)$$

$$C \quad DCIW = 1$$

- CPIW - Communication in Process Orders at Independent Woodyards (cords)
 DT - Solution Time Interval

- ODIW - Order Decision at Independent Woodyards (cords/week)
- RRIH - Requisitions Received from Independent Woodyards at Independent Harvesters (cords/week)
- RRIW - Requisitions Received at Independent Woodyard from Mill (cords/week)
- DCIW - Delay in Communications between the Independent Harvesters and the Independent Woodyards (weeks)

To fill the orders sent from the independent woodyards, there is wood flowing to the independent woodyards. A shorthaul trucking delay is encountered by the wood in transit to the independent woodyards, and because of the delay, an accumulation of wood in transit is formed. This accumulation is fed by the rate of wood sent to the independent woodyards from the independent harvesters and is drained by the rate at which wood is received at the independent woodyards. The transportation (shorthaul trucking) delay is between the independent harvesters and the independent woodyards is taken as .3 weeks. This shorthaul trucking delay may be slightly longer than in reality but was used for model formulation purposes. The difference will not affect the aggregate system.

$$\begin{aligned}
 1L \quad & PTIW.K = PTIW.J + (DT)(PSIHW.JK - PRIIW.JK) \\
 12N \quad & PTIW = (RRIW)(DTIW) \\
 39R \quad & PRIIW.KL = DELAY3(PSIHW.JK, DTIW) \\
 C \quad & DTIW = .3
 \end{aligned}$$

- PTIW - Pulpwood in Transit between Independent Harvesters and Independent Woodyards (cords/week)
- DT - Solution Time Interval (weeks)
- PSIHW - Pulpwood Sent to Independent Woodyards from Independent Harvesters (cords/week)
- PRIIW - Pulpwood Received from Independent Harvesters at Independent Woodyards (cords/week)
- RRIW - Requisitions Received at Independent Woodyards from Mill (cords/week)
- DTIW - Delay in Transportation from Independent Harvesters to Independent Woodyards (weeks)

A complete flow diagram of the independent woodyards sector is shown in Figure 4.

Dealer Woodyards Sector

The basic structure of the dealer woodyards sector is similar to that of the independent woodyards sector except that the dealer woodyards obtain wood from both independent and dealer harvesters. Because the dealer woodyards do have contracts with the mill, they are more dependable and generally react faster than do the independent woodyards.

The unfilled orders at the dealer woodyards are represented in the model by an accumulation of the requisitions received at the dealer woodyards less the pulp sent to the mill from the dealer woodyards. The unfilled orders normal equal the rate of orders received times the minimum delay in handling an order.

$$\begin{aligned} 1L \quad & \text{UODW. } K = \text{UODW. } J + (\text{DT})(\text{RRDW. } JK - \text{PSDW. } JK) \\ 12N \quad & \text{UODW} = (\text{RRDW})(\text{DHDW}) \\ 12A \quad & \text{UNDW. } K = (\text{RRDW. } JK)(\text{DHDW}) \end{aligned}$$

UODW - Unfilled Orders at the Dealer Woodyards (cords)
 DT - Solution Time Interval (weeks)
 RRDW - Requisitions Received at the Dealer Woodyards from
 the Mill (cords/week)
 PSDW - Pulpwood Sent from the Dealer Woodyards to Mill (cords/week)
 DHDW - Delay Due to Minimum Handling at Dealer Woodyards (weeks)
 UNDW - Unfilled Orders Normal at Dealer Woodyards (cords)

The inventory actual at the dealer woodyards is defined as a level which grows as a result of wood received from both the independent and dealer harvesters. The level diminishes as a result of the wood sent to the mill from the dealer woodyards.

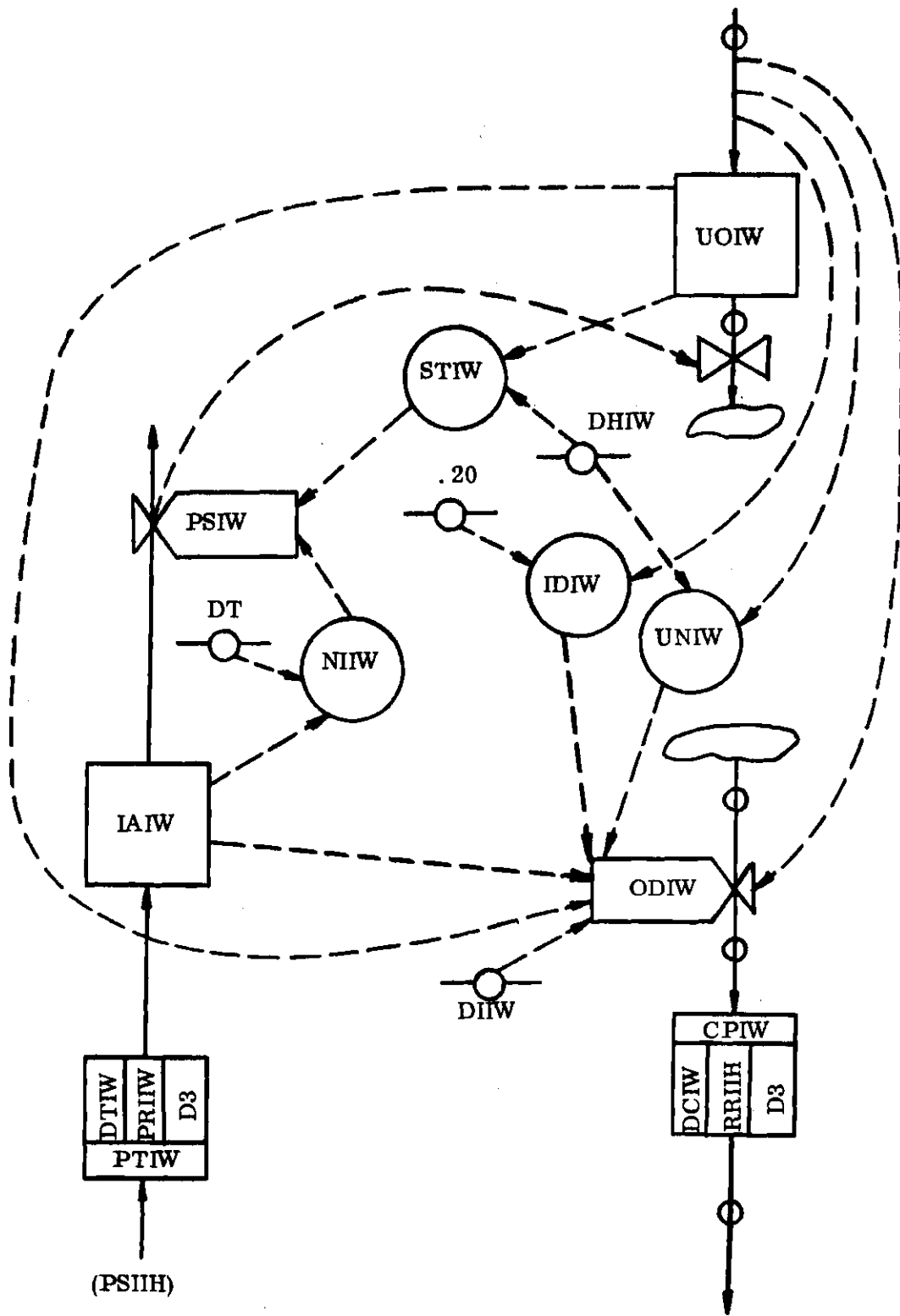

Figure 4. Flow Diagram of Independent Woodyards Sector.

52L $IADW.K = IADW.J + (DT)(PRIDW.JK + PRDDW.JK - PSDW$
 $.JK + 0)$
 6N $IADW = IDDW$

IADW - Inventory Actual at the Dealer Woodyards (cords)
 DT - Solution Time Interval (weeks)
 PRIDW - Pulpwood Received from Independent Harvesters at Dealer
 Woodyards (cords/week)
 PRDDW - Pulpwood Received from Dealer Harvesters at Dealer
 Woodyards (cords/week)
 PSDW - Pulpwood Sent from Dealer Woodyards to Mill (cords/week)
 IDDW - Inventory Desired at Dealer Woodyards (cords)

The dealer woodyards would ideally like to fill all unfilled orders in the minimum time possible. This can be done until all actual inventory is depleted. A clip function is used in the model to insure that the dealer woodyards do not ship more wood than is available in inventory at that particular time period. The minimum order processing and physical shipping time is taken to be one week.

51R $PSDW.KL = CLIP(STDW.K, NIDW.K, NIDW.K, STDW.K)$
 20A $STDW.K = UODW.K / DHDW$
 C $DHDW = 1$
 20A $NIDW.K = IADW.K / DT$

PSDW - Pulpwood Sent from Dealer Woodyards to Mill (cords/week)
 STDW - Shipping Rate Tried at Dealer Woodyards (cords/week)
 NIDW - Negative Inventory Limit Rate at Mill (cords/week)
 UODW - Unfilled Orders at Dealer Woodyards (cords)
 DHDW - Minimum Delay due to Handling at Dealer Woodyards (weeks)
 IADW - Inventory Actual at Dealer Woodyards (cords)
 DT - Solution Time Interval (weeks)

The dealer woodyards also desire to have a certain supply of wood on hand at all times. At the same time, the inventory on hand must not become so large that the wood remains on the yard for any length of time. Wood left on the yard will begin to rot after a relatively short period of time. In the model, the dealer

woodyards desire to have .5 weeks supply of wood on hand.

$$12A \quad \text{IDDW. K}=(\text{ADW})(\text{RRDW. K})$$

$$C \quad \text{ADW}=.5$$

- IDDW - Inventory Desired at Dealer Woodyards (cords)
 ADW - Proportionality Constant between Inventory Desired and Requisitions Received at Dealer Woodyards (weeks)
 RRDW - Requisitions Received at Dealer Woodyards from Mill (cords/week)

Once the dealer woodyards receive orders from the mill, they must place orders to their respective independent and dealer harvesters. The decision to place orders is based on the requisitions being received at that time period, the difference between desired inventory and actual inventory, and the difference between actual unfilled orders and normal unfilled orders. The dealer woodyards must order enough wood to fill the requisitions being received, and to balance, over a period of time, the difference between the desired and actual inventories and the difference between actual unfilled orders and normal unfilled orders. The period of adjusting the inventories and unfilled orders is taken to be six weeks.

$$40R \quad \text{ODDW. KL}=\text{RRDW. JK}+(1/\text{DIDW})(\text{IDDW. K}-\text{IADW. K}+\text{UODW. K}-\text{UNDW. K})$$

$$C \quad \text{DIDW}=6$$

- ODDW - Order Decision at Dealer Woodyards (cords/week)
 RRDW - Requisitions Received at Dealer Woodyards from Mill (cords/week)
 DIDW - Delay in Adjusting Inventory at Dealer Woodyards (weeks)
 IDDW - Inventory Desired at Dealer Woodyards (cords)
 IADW - Inventory Actual at Dealer Woodyards (cords)
 UODW - Unfilled Orders at Dealer Woodyards (cords)
 UNDW - Unfilled Orders Normal at Dealer Woodyards (cords)

The order decision rate flows into a level representing total orders sent

from dealer woodyards. Of the total orders sent from dealer woodyards, a certain percentage of these orders are sent to dealer harvesters and the remaining orders are sent to independent harvesters. The exact percentage of the orders to the respective harvesters will vary with each dealer woodyard. Representative average percentages are used in the model.

```

52L  TOSDW. K=TOSDW. J+(DT)(ODDW. JK-OSIDW. JK-OSDDW
      . JK-O)
6N   TOSDW=RRDW
12R  OSIDW. KL=(IHDP)(TOSDW. K)
C    IHDP=. 40
12R  OSDDW. KL=(DHDP)(TOSDW. K)
C    DHDP=. 60

```

TOSDW - Total Orders Sent from Dealer Woodyards (cords)
DT - Solution Time Interval (weeks)
ODDW - Order Decision at Dealer Woodyards (cords/week)
OSIDW - Orders Sent to Independent Harvesters from Dealer Woodyards (cords/week)
OSDDW - Orders Sent to Dealer Harvesters from Dealer Woodyards (cords/week)
RRDW - Requisition Received at Dealer Woodyards from Mill (cords/week)
IHDP - Percentage to Independent Harvesters from Dealer Woodyards (1/weeks)
DHDP - Percentage to Dealer Harvesters from Dealer Woodyards (1/weeks)

Once the orders have been sent to the respective harvesters, a communications delay in contacting the harvesters occurs. Because the orders are delayed in reaching the harvesters, a level of communication in process orders is formed for both the independent and dealer harvesters. The communications delay is represented in the model by a third-order delay function. The input for the delay function is the rate of orders sent to the respective harvesters from the dealer

woodyards. The output is the rate of requisitions received at the respective harvesters from the dealer woodyards. The communications delay constant, to both the independent and dealer harvesters, is taken to be one week.

1L $CPIDW, K=CPIDW, J+(DT)(OSIDW, JK-RRDIH, JK)$
 13N $CPIDW=(RRDW)(IHDP)(DCIDW)$
 39R $RRDIH.KL=DELAY3(OSIDW, JK, DCIDW)$
 C $DCIDW=1$
 1L $CPDDW, K=CPDDW, J+(DT)(OSDDW, JK-RRDDH, JK)$
 13N $CPDDW=(RRDW)(DHDP)(DCDDW)$
 39R $RRDDH, KL=DELAY3(OSDDW, JK, DCDDW)$
 C $DCDDW=1$

CPIDW - Communication in Process Orders to Independent Harvesters from Dealer Woodyards (cords)
 DT - Solution Time Interval (weeks)
 OSIDW - Orders Sent to Independent Harvesters from Dealer Woodyards (cords/week)
 RRDIH - Requisitions Received from Dealer Woodyards at Independent Harvesters (cords/week)
 RRDW - Requisitions Received at Dealer Woodyards from Mill (cords/week)
 IHDP - Percentage to Independent Harvesters from Dealer Woodyards (1/weeks)
 DCIDW - Delay in Communications between Independent Harvesters and Dealer Woodyards (weeks)
 CPDDW - Communication in Process Orders to Dealer Harvesters from Dealer Woodyards (cords)
 OSDDW - Orders Sent to Dealer Harvesters from Dealer Woodyards (cords/week)
 RRDDH - Requisitions Received from Dealer Woodyards at Dealer Harvesters (cords/week)
 DHDP - Percentage to Dealer Harvesters from Dealer Woodyards (1/weeks)
 DCDDW - Delay in Communications between Dealer Harvesters and Dealer Woodyards (weeks)

To fill the orders sent from the dealer woodyards, there is wood flowing to the woodyards from the harvesters. A transportation (shorthaul trucking) delay is encountered by the wood in transit from both independent and dealer harvesters

to the dealer woodyards. These transportation delays are represented by third-order delay functions. The input to each delay function is the rate of wood sent to the dealer woodyards from the respective harvesters. The output is the rate of wood received at the dealer woodyards from the respective harvesters. The transportation delay constants, from both the independent and dealer harvesters, are taken to be .3 weeks.

```

1L   PTIDW. K=PTIDW. J+(DT)(PSDIH. JK-PRIDW. JK)
13N  PTIDW=(RRDW)(IHDP)(DTDIH)
39R  PRIDW. KL=DELAY3(PSDIH. JK, DTDIH)
C    DTDIH=.3
1L   PTDDW. K=PTDDW. J+(DT)(PSDOH. JK-PRDDW. JK)
13N  PTDDW=(RRDW)(DHDP)(DTDDH)
39R  PRDDW. KL=DELAY3(PSDDH. JK, DTDDH)
C    DTDDH=.3

```

PTIDW - Pulpwood in Transit between Independent Harvesters and Dealer Woodyards (cords)

DT - Solution Time Interval (weeks)

PSDIH - Pulpwood Sent to Dealer Woodyards from Independent Harvesters (cords/week)

PRIDW - Pulpwood Received from Independent Harvesters at Dealer Woodyards (cords/week)

RRDW - Requisitions Received at Dealer Woodyards from Mill (cords/week)

IHDP - Percentage to Independent Harvesters from Dealer Woodyards (1/weeks)

DTDIH - Delay in Transportation between Dealer Woodyards and Independent Harvesters (weeks)

PTDDW - Pulpwood in Transit between Dealer Harvesters and Dealer Woodyards (cords)

PSDDH - Pulpwood Sent to Dealer Woodyards from Dealer Harvesters (cords/week)

PRDDW - Pulpwood Received from Dealer Harvesters at Dealer Woodyards (cords/week)

DHCP - Percentage to Dealer Harvesters from Dealer Woodyards (1/weeks)

DTDDH - Delay in Transportation to Dealer Woodyards from Dealer Harvesters (weeks)

A complete flow diagram of the dealer woodyards sector is shown in Figure 5.

Company Woodyards Sector

Generally, the largest portion of wood received at the mill comes from company woodyards. One reason for this is that the company woodyards receive pulpwood from all three classes of harvesters. Also, because they have better equipment, the company woodyards are usually more efficient in their operations.

The unfilled orders at the company woodyards are represented in the model by an accumulation of the orders received from the mill minus the shipments sent to the mill. The unfilled orders normal at the company woodyards are equal to the rate of orders received times the minimum delay in handling orders.

$$\begin{aligned}
 1L \quad & \text{UOCW. K} = \text{UOCW. J} + (\text{DT})(\text{RRCW. JK} - \text{PSCW. JK}) \\
 12N \quad & \text{UOCW} = (\text{RRCW})(\text{DHCW}) \\
 12A \quad & \text{UNCW. K} = (\text{RRCW. JK})(\text{DHCW})
 \end{aligned}$$

- UOCW - Unfilled Orders at the Company Woodyards (cords)
- DT - Solution Time Interval (weeks)
- RRCW - Requisition Received at Company Woodyards from Mill (cords/week)
- PSCW - Pulpwood Sent from Company Woodyards to Mill (cords/week)
- DHCW - Minimum Delay in Handling at Company Woodyards (weeks)
- UNCW - Unfilled Orders Normal at Company Woodyards (cords)
- PSCW - Pulpwood Sent from Company Woodyards to Mill (cords/week)
- STCW - Shipping Rate Tried at Company Woodyards (cords/week)
- NICW - Negative Inventory Limit Rate at Company Woodyards (cords/week)
- UOCW - Unfilled Orders at Company Woodyards (cords)
- DHCW - Minimum Delay in Handling at Company Woodyards (weeks)
- IACW - Inventory Actual at Company Woodyards (cords)

The company woodyards also desire to keep a certain supply of wood on

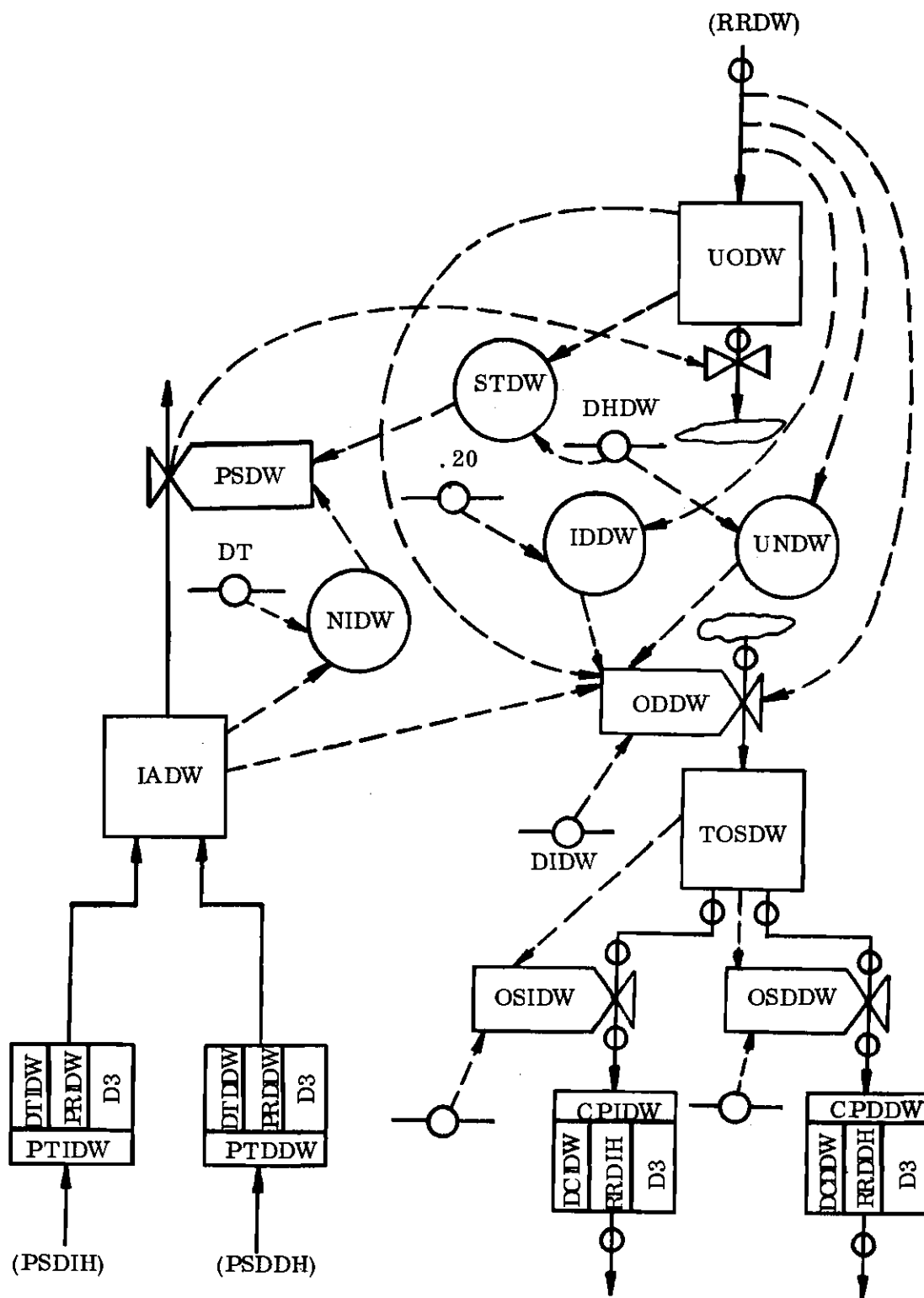

Figure 5. Flow Diagram of Dealer Woodyards Sector.

hand. The inventory desired on hand must be kept at a minimum to prevent the wood from remaining on the yard for any length of time. The woodyards desire some inventory so they will be prepared for any unexpected rises in demand. The inventory desired at the company woodyards is taken to be .5 weeks supply.

$$12A \quad IDCW, K = (ACW)(RRCW, K)$$

$$C \quad ACW = .5$$

IDCW - Inventory Desired at Company Woodyards (cords)
 ACW - Proportionality Constant between the Inventory Desired and the Requisitions Received at the Company Woodyards (1/weeks)
 RRCW - Requisitions Received at the Company Woodyards from the Mill (cords/week)

The decision order rate at the company woodyards is based on the rate of requisitions received at the company woodyards, the difference between actual and desired inventories, and the difference in the actual and normal unfilled orders. The company woodyards order enough wood to fill the incoming orders and to adjust, over a period of time, any difference in desired and actual inventories and any difference in actual and normal unfilled orders. The period of adjusting the inventories and unfilled orders is taken to be six weeks.

Inventory actual at the company woodyards is also represented in the model by an accumulation. This accumulation is fed by the rate of pulpwood received from each of the three classes of harvesters. The accumulation is emptied by the rate of pulpwood sent to the mill from the company woodyards.

$$52L \quad IACW, K = IACW, J + (DT)(PRICW, JK + PRDCW, JK + PRCCW, JK - PSCW, JK)$$

$$6N \quad IACW = IDCW$$

- IACW - Inventory Actual at Company Woodyards (cords)
- DT - Solution Time Interval (weeks)
- PRICW - Pulpwood Received from Independent Harvesters at Company Woodyards (cords/week)
- PRDCW - Pulpwood Received from Dealer Harvesters at Company Woodyards (cords/week)
- PRCCW - Pulpwood Received from Company Harvesters at Company Woodyards (cords/week)
- PSCW - Pulpwood Sent from Company Woodyards to Mill (cords/week)
- IDCW - Inventory Desired at Company Woodyards (cords)

The company woodyards would like to fill all unfilled orders as rapidly as possible. But, as was the case with the other woodyards, it cannot ship more pulpwood than it presently has in inventory. Therefore, a clip function is used to ensure that the model does not attempt to ship more pulpwood than is present in inventory. The shipping rate first tried is determined by dividing the unfilled orders by the minimum delay in handling orders. The minimum delay to process and physically fill an order is taken as .5 weeks.

- 51R $PSCW.KL = CLIP(STCW.K, NICW.K, NICW.K, STCW.K)$
- 20A $STCW.K = UOCW.K / DHCW$
- C $DHCW = .5$
- 20A $NICW.K = IACW.K / DT$
- 40R $ODCW.KL = RRCW.JK + (1/DICW)(IDCW.K - IACW.K + UOCW.K - UNCW.K)$
- C $DICW = 6$

- ODCW - Order Decision Rate at Company Woodyards (cords/week)
- RRCW - Requisitions Received at Company Woodyards from Mill (cords/week)
- DICW - Delay in Inventory Adjustment at Company Woodyards (weeks)
- IDCW - Inventory Desired at Company Woodyards (cords)
- IACW - Inventory Actual at Company Woodyards (cords)
- UOCW - Unfilled Orders at Company Woodyards (cords)
- UNCW - Unfilled Orders Normal at Company Woodyards (cords)

The order decision rate serves as the input to a level of total orders sent

from the company woodyards. The outputs of this level are the rates of orders sent to the independent, dealer, and company harvesters. The percentage, of total orders sent, that goes to each of the respective harvesters will vary for different woodyards. Representative averages of these percentages are used in the model and can be easily adjusted to better fit any particular case.

52L $TOSCW, K = TOSCW, J + (DT)(ODCW, JK - OSICW, JK - OSDCW, JK - OSCCW, JK)$
 6N $TOSCW = RRCW$
 12R $OSICW, KL = (IHCP)(TOSCW, K)$
 C $IHCP = .70$
 12R $OSDCW, KL = (DHCP)(TOSCW, K)$
 C $DHCP = .25$
 12R $OSCCW, KL = (CHCP)(TOSCW, K)$
 C $CHCP = .05$

TOSCW - Total Orders Sent from Company Woodyards (cords)
 DT - Solution Time Interval (weeks)
 ODCW - Order Decision Rate at Company Woodyards (cords/week)
 OSICW - Orders Sent to Independent Harvesters from Company Woodyards (cords/week)
 OSDCW - Orders Sent to Dealer Harvesters from Company Woodyards (cords/week)
 OSCCW - Orders Sent to Company Harvesters from Company Woodyards (cords/week)
 TOSCW - Total Orders Sent from Company Woodyards (cords)
 RRCW - Requisitions Received at Company Woodyards from Mill (cords/week)
 IHCP - Percentage to Independent Harvesters from Company Woodyards (1/weeks)
 DHCP - Percentage to Dealer Harvesters from Company Woodyards (1/weeks)
 CHCP - Percentage to Company Harvesters from Company Woodyards (1/weeks)

Once the order decisions have been made, there is a communications delay in contacting the harvesters. Because of this communications delay, a level of communication in process orders is formed for each of the three categories of

of harvesters. The rate of orders sent to the respective harvesters is the input of each communication in process level, and the rate of orders received at the respective harvesters is the output. This communications delay is represented in the model by a third-order delay function. The communications delay to the company harvesters is less than the delay to the independent and dealer harvesters. This is because the company woodyards and company harvesters communicate through fixed channels.

```

1L  CPICW. K=CPICW. J+(DT)(OSICW. JK-RRCIH. JK)
13N CPICW=(RRCW)(IHCP)(DCICW)
39R RRCIH. KL=DELAY3(OSICW. JK, DCICW)
C   DCICW=1
1L  CPDCW. K=CPDCW. J+(DT)(OSDCW. JK-RRCDH. JK)
13N CPDCW=(RRCW)(DHCP)(DCDCW)
39R RRCDH. KL=DELAY3(OSDCW. JK, DCDCW)
C   DCDCW=1
1L  CPCCW. K=CPCCW. J+(DT)(OSCCW. JK-RRCCH. JK)
13N CPCCW=(RRCW)(CHCP)(DCCW)
39R RRCCH. KL=DELAY3(OSCCW. JK, DCCW)
C   DCCW=.5

```

CPICW - Communications in Process Orders to Independent Harvesters from Company Woodyards (cords)

DT - Solution Time Interval (weeks)

OSICW - Orders Sent to Independent Harvesters from Company Woodyards (cords/week)

RRCIH - Requisitions Received from Company Woodyards at Independent Harvesters (cords/week)

RRCW - Requisition Received at Company Woodyards from Mill (cords/week)

IHCP - Percentage to Independent Harvesters from Company Woodyards (1/weeks)

DCICW - Delay in Communications between Independent Harvesters and Company Woodyards (weeks)

CPDCW - Communication in Process Orders to Dealer Harvesters from Company Woodyards (weeks)

OSDCW - Orders Sent to Dealer Harvesters from Company Woodyards (cords/week)

- RRCDH - Requisitions Received from Company Woodyards at Dealer Harvesters (cords/week)
- DHCP - Percentage to Dealer Harvesters from Company Woodyards (1/weeks)
- DCDCW - Delay in Communications between Dealer Harvesters and Company Woodyards (weeks)
- CPCCW - Communication in Process Orders to Company Harvesters from Company Woodyards (weeks)
- OSCCW - Orders Sent to Company Harvesters from Company Woodyards (orders/week)
- RRCCH - Requisitions Received from Company Woodyards at Company Harvesters (cords/week)
- CHCP - Percentage to Company Harvesters from Company Woodyards (1/weeks)
- DCCCW - Delay in Communications between Company Harvesters and Company Woodyards (weeks)

To fill the orders sent from the company woodyards, pulpwood is flowing from the harvesters to the company woodyards. A transportation (shorthaul trucking) delay occurs between the harvesters and the woodyards. This delay creates an accumulation of pulpwood in transit from each of the respective harvesters to the company woodyards. These accumulations are filled by the rate of pulpwood sent to the company woodyards from the respective harvesters. The accumulations are depleted by the rate of pulpwood that is actually received by the company woodyards. A third-order delay function was used to represent the transportation delay in the model. The transportation delay from each of the harvesters is taken to be .3 weeks.

1L PTICW. K=PTICW. J+(DT)(PSCIH. JK-PRICW. JK)

13N PTICW=(RRCW)(IHCP)(DTCIH)

39R PRICW. KL=DELAY3(PSCIH. JK, DTCIH)

C DTCIH=.3

1L PTDCW. K=PTDCW. J+(DT)(PSCDH. JK-PRDCW. JK)

13N PTDCW=(RRCW)(DHCP)(DTCDH)

39R PRICW. KL=DELAY3(PSCIH. JK, DTCIH)
 C DTCIH=. 3
 1L PTDCW. K=PTDCW. J+(DT)(PSCDH. JK-PRDCW. JK)
 13N PTDCW=(RRCW)(DHCP)(DTCDH)
 39R PRDCW. KL=DELAY3(PSCDH. JK, DTCDH)
 C DTCDH=. 3
 1L PTCCW. K=PTCCW. J+(DT)(PSCCH. JK-PRCCW. JK)
 13N PTCCW=(RRCW)(CHCP)(DTCCH)
 39R PRCCW. KL=DELAY3(PSCCH. JK, DTCCH)
 C DTCCH=. 3

PTICW - Pulpwood in Transit between the Independent Harvesters
 and the Company Woodyards (cords)
 DT - Solution Time Interval (weeks)
 PSCIH - Pulpwood Sent to Company Woodyards from Independent
 Harvesters (cords/week)
 PRICW - Pulpwood Received from Independent Harvesters at
 Company Woodyards (cords/week)
 RRCW - Requisitions Received at Company Woodyards from Mill
 (cords/week)
 IHCP - Percentage to Independent Harvesters from Company
 Woodyards (1/weeks)
 DTCIH - Delay in Transportation to Company Woodyards from
 Independent Harvesters (weeks)
 PTDCW - Pulpwood in Transit between Dealer Harvesters and
 Company Woodyards (cords)
 PSCDH - Pulpwood Sent to Company Woodyards from Dealer
 Harvesters (cords/week)
 PRDCW - Pulpwood Received from Dealer Harvesters at Company
 Woodyards (cords/week)
 DHCP - Percentage to Dealer Harvesters from Company Woodyards
 (1/weeks)
 DTCDH - Delay in Transportation to Company Woodyards from
 Dealer Harvesters (weeks)
 PTCCW - Pulpwood in Transit from Company Harvesters to Company
 Woodyards (cords)
 PSCCH - Pulpwood Sent to Company Woodyards from Company Harves-
 ters (cords/week)
 PRCCW - Pulpwood Received from Company Harvesters at Company
 Woodyards (cords/week)
 CHCP - Percentage to Company Harvesters from Company Woodyards
 (1/weeks)
 DTCCH - Delay in Transportation to Company Woodyards from Company
 Harvesters

A complete flow diagram of the company woodyards sector is shown in Figure 6.

Independent Harvesters Sector

The independent harvester is presently the key figure in the production of pulpwood in the South. He accounts for well over fifty per cent of all pulpwood harvested in the South (7).

The aggregated independent harvesters receive orders from independent, dealer, and company woodyards. A level of unfilled orders is formed by the orders from each of the woodyards. These levels are defined separately for model calculation purposes. The rate of requisitions received from the respective woodyards is the input to the levels and rate of pulpwood sent by the independent harvesters to the respective woodyards is the output.

$$\begin{aligned}
 1L \quad & UO_{IH} \cdot K = UO_{IH} \cdot J + (DT)(RR_{IH} \cdot JK - PS_{IH} \cdot JK) \\
 12N \quad & UO_{IH} = (RR_{IH})(DT) \\
 1L \quad & UOD_{IH} \cdot K = UOD_{IH} \cdot J + (DT)(RR_{DIH} \cdot JK - PS_{DIH} \cdot JK) \\
 12N \quad & UOD_{IH} = (RR_{DIH})(DT) \\
 1L \quad & UOC_{IH} \cdot K = UOC_{IH} \cdot J + (DT)(RR_{CIH} \cdot JK - PS_{CIH} \cdot JK) \\
 12N \quad & UOC_{IH} = (RR_{CIH})(DT) \\
 8A \quad & UO_{IH} \cdot K = UO_{IH} \cdot K + UOD_{IH} \cdot K + UOC_{IH} \cdot K \\
 12A \quad & UN_{IH} \cdot K = (RR_{IH} \cdot K)(DT)
 \end{aligned}$$

UO _{IH}	- Unfilled Orders from Independent Woodyards at Independent Harvesters (cords)
DT	- Solution Time Interval (weeks)
RR _{IH}	- Requisitions Received from Independent Woodyards at Independent Harvesters (cords/week)
PS _{IH}	- Pulpwood Sent to Independent Woodyards from Independent Harvesters (cords/week)
UOD _{IH}	- Unfilled Orders from Dealer Woodyards at Independent Harvester (cords)
RR _{DIH}	- Requisitions Received from Dealer Woodyards at Independent Harvester (cords/week)

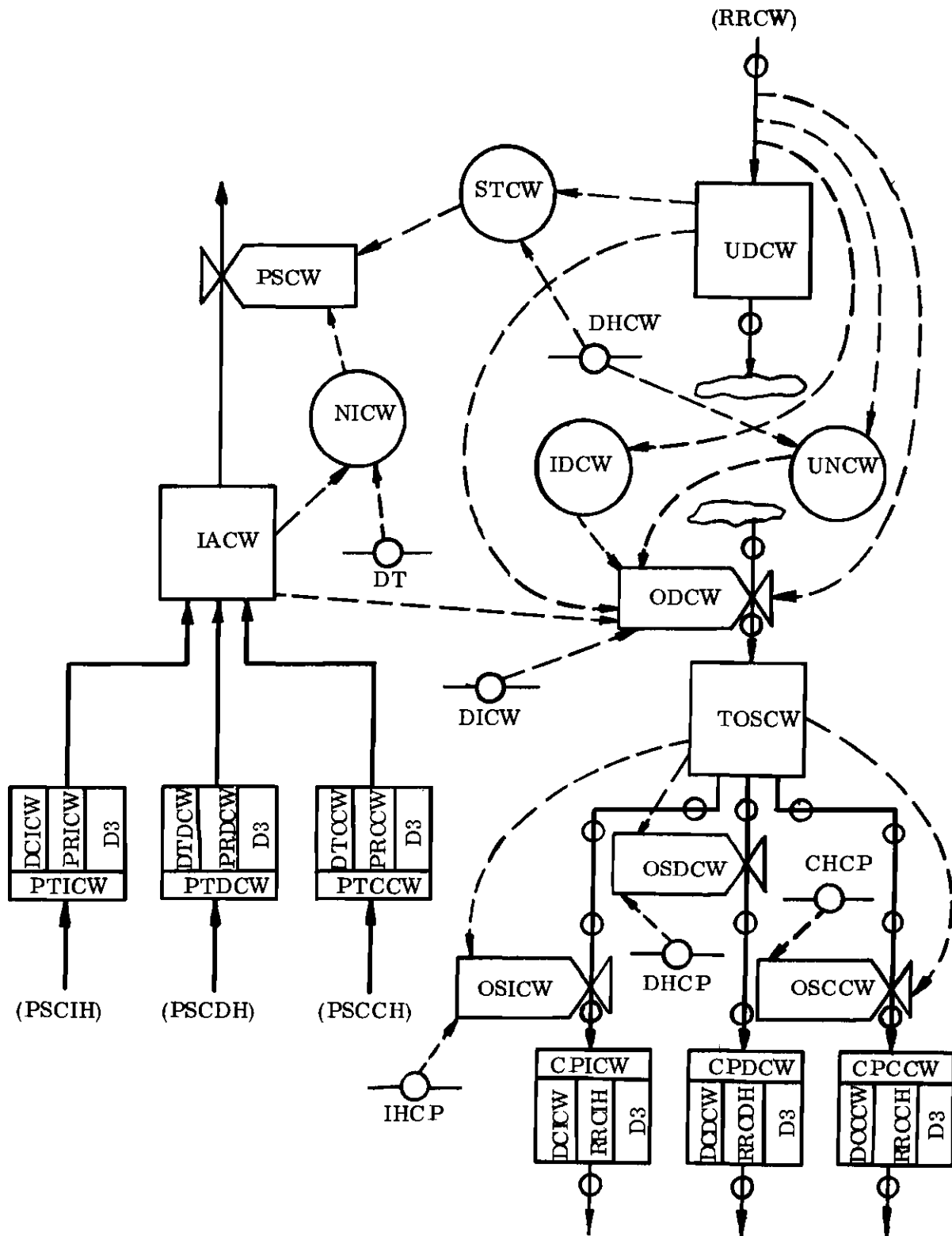

Figure 6. Flow Diagram of Company Woodyards Sector.

- PSDIH - Pulpwood Sent to Dealer Woodyards from Independent Harvesters (cords/week)
- UOCHH - Unfilled Order from Company Woodyards at Independent Harvesters (cords)
- RRCIH - Requisitions Received from Company Woodyards at Independent Harvesters (cords/week)
- PSCIH - Pulpwood Sent to Company Woodyards from Independent Harvesters (cords/week)
- UOIH - Unfilled Orders at Independent Harvesters (cords)
- UNIH - Unfilled Orders Normal at Independent Harvesters (cords)

The inventory actual at the independent harvesters is defined as a level which is filled by the rate of pulpwood being cut and emptied by the rates of pulpwood sent to the various woodyards.

$$52L \quad IAIH. K = IAIH. J + (DT)(CRIH. JK - PSIIH. JK - PSDIH. JK - PSCIH. JK)$$

$$8N \quad IAIH = IDIH$$

- IAIH - Inventory Actual at Independent Harvesters (cords)
- DT - Solution Time Interval (weeks)
- CRIH - Cutting Rate at Independent Harvester (cords/week)
- PSIIH - Pulpwood Sent to Independent Woodyards from Independent Harvesters (cords/week)
- PSDIH - Pulpwood Sent to Dealer Woodyards from Independent Harvesters (cords/week)
- PSCIH - Pulpwood Sent to Company Woodyards from Independent Harvesters (cords/week)
- IDIH - Inventory Desired at Independent Harvesters (cords)

Essentially there is no handling delay at the independent harvesters. They can fill an order immediately if the wood has been cut. Therefore, the shipping rate tried is equal to the unfilled orders divided by the solution time interval (the minimum delay allowed by the modeling language). A clip function is used to ensure that the model does not attempt to ship more pulpwood than is present in inventory. For the purposes of the model formulation, separate shipping functions

are used for shipments to each of the three classes of woodyards.

51R $PSIH.KL=CLIP(STIH.K, NIIH.K, NIIH.K, STIH.K)$
 51R $PSDIH.KL=CLIP(STDIH.K, NDIH.K, NIIH.K, STDIH.K)$
 51R $PSCIH.KL=CLIP(STCIH.K, NCIH.K, NIIH.K, STCIH.K)$
 20A $STIH.K=UOIH.K/DT$
 20A $STDIH.K=UODIH.K/DT$
 20A $STCIH.K=UOCIH.K/DT$
 46A $NIIH.K=(RRIH.JK)(IAIH.K)(1)/((RRIH.K)(DT)(1))$
 46A $NDIH.K=(RRDIH.JK)(IAIH.K)(1)/((RRIH.K)(DT)(1))$
 46A $NCIH.K=(RRCIH.JK)(IAIH.K)(1)/((RRIH.K)(DT)(1))$

PSIH - Pulpwood Sent to Independent Woodyards from Independent Harvesters (cords/week)
 STIH - Shipping Rate Tried to Independent Woodyards from Independent Harvesters (cords/week)
 NIIH - Negative Inventory Limit Rate to Independent Woodyards from Independent Harvesters (cords/week)
 PSDIH - Pulpwood Sent to Dealer Woodyards from Independent Harvesters (cords/week)
 STDIH - Shipping Rate Tried to Dealer Woodyards from Independent Harvesters (cords/week)
 NDIH - Negative Inventory Limit Rate to Dealer Woodyards from Independent Harvesters (cords/week)
 PSCIH - Pulpwood Sent to Company Woodyards from Independent Harvesters (cords/week)
 STCIH - Shipping Rate Tried to Company Woodyards from Independent Harvesters (cords/week)
 NCIH - Negative Inventory Limit Rate to Company Woodyards from Independent Harvesters (cords/week)
 UOIH - Unfilled Orders from Independent Woodyards at Independent Harvesters (cords)
 DT - Solution Time Interval (weeks)
 UODIH - Unfilled Orders from Dealer Woodyards at Independent Harvesters (cords)
 UOCIH - Unfilled Orders from Company Woodyards at Independent Harvesters (cords)
 RRIH - Requisitions Received from Independent Woodyards at Independent Harvesters (cords/weeks)
 IAIH - Inventory Actual at Independent Harvesters (cords)
 RRIH - Total Requisitions Received at Independent Harvesters (cord/week)
 RRDIH - Requisitions Received from Dealer Woodyards at Independent Harvesters (cords/week)

RRCIH - Requisitions Received from Company Woodyards at Independent Harvesters (cords/week)

Unlike the woodyards, the harvesters desire to have almost no inventory on hand. This is because most harvesters work from a day-to-day basis and do not want any wood on hand which has not already been sold. The independent harvesters desire to have only a small percentage of weekly orders on hand at any time. For purposes of model formulation, the inventory desired at the independent harvesters is broken down into three components, one for each type of woodyard.

6A $IDDIH, K = (RRIIH, K) (.20)$
 6A $RRDIH, K = (RRDIH, K) (.20)$
 6A $IDCIH, K = (RRCIH, K) (.20)$
 8A $IDIH, K = IDCIH, K - IDDIH, K - IDIHH, K$

IDIH - Inventory Desired for Independent Woodyards at Independent Harvesters (cords)
 RRIIH - Requisitions Received from Independent Woodyards at Independent Harvesters (cords/week)
 IDDIH - Inventory Desired for Dealer Woodyards at Independent Harvesters (cords)
 RRDIH - Requisitions Received from Dealer Woodyards at Independent Harvesters (cords/week)
 IDCIH - Inventory Desired for Company Woodyards at Independent Harvesters (cords)
 RRCIH - Requisitions Received from Company Woodyards at Independent Harvesters (cords/week)
 IDIH - Total Inventory Desired at Independent Harvesters (cords)

Independent harvesters do not desire to have a backlog of unfilled orders. They try to fill all orders as they receive them. The rate of pulpwood needed to be cut by the independent harvesters is based on the total unfilled orders plus any difference in desired and actual inventories plus any difference in actual and normal

unfilled orders. The difference quantities are divided by the solution time interval in order to convert them to a weekly rate.

$$25A \quad PNCIH, K = RRIH, K + (1/DT)(IDIH, K - IAIH, K + UOIH, K - UNIH, K + O + O)$$

- PNCIH - Pulpwood Needed Cut at Independent Harvesters (cords/week)
 RRIH - Total Requisitions Received at Independent Harvesters (cords/week)
 DT - Solution Time Interval (weeks)
 IDIH - Inventory Desired at Independent Harvesters (cords)
 IAIH - Inventory Actual at Independent Harvesters (cords)
 UOIH - Total Unfilled Orders at Independent Harvesters (cords)
 UNIH - Unfilled Orders Normal at Independent Harvesters (cords)

The cutting capacity at the independent harvesters is determined by multiplying the number of producer crews times the productivity per crew per week. The productivity per crew per week is used as a constant in the model; however, this figure can be changed to reflect such factors as varying investments in capital equipment, varying aggressiveness factors, varying stand conditions, etc. The productivity per crew per week is much lower for the independent harvesters than for the dealer and company harvesters. This is because the independent can not afford to invest in large equipment and machinery.

$$12A \quad CCIH, K = (PIH, K)(PPIH)$$

$$C \quad PPIH = 25$$

- CCIH - Cutting Capacity at Independent Harvesters (cords/week)
 PIH - Producer Crews at Independent Harvesters (crews)
 PPIH - Productivity per Producer Crew at Independent Harvesters (cords/crew/week)

The number of producer crews at the independent harvesters is represented in the model by a level which is filled and drained by the rate at which producer

crews are added.* The rate at which producer crews are added depends on the difference in the rate of pulpwood needed to be cut and the actual cutting capacity. If there are enough crews to produce the pulpwood needed then no crews will be added. If the producer crews are capable of producing more pulpwood than is needed, some of the crews will be released. The total increase in crews added is limited to a maximum increase of 30 per cent. The rate of adding crews is represented as a first-order exponential delay.** The delay constant for adding crews is taken to be six weeks. The rate of adding crews at the independent harvesters is limited to a maximum of one crew per two weeks.

54A $PIH.K = \text{MIN}(PIH1.K, PIH2)$
 1L $PIH1.K = PIH.J + (DT)(ARIH.JK - O)$
 24N $PIH1 = (1/PPIH)(RRIIH + RRDIH + RRCIH + O + O + O)$
 46A $PIH2.K = (A)(3100)(AA.K) / ((PPIH)(1)(1))$
 C $A + 1.30$
 17A $AA.K = (IWP)(1)(1)(1) + (CWP)(IHDP)(1) + (CWP)(IHCP)(1)$
 54A $ARIH.KL = \text{MIN}(ARIH1.JK, .5)$
 42R $ARIH1.KL = \text{DIFF}1.K / ((PPIH)(DAIH))$
 C $DAIH = 6$
 7A $\text{DIFF}1.K = PNCIH.K - CCIH.K$

PIH - Producer Crews at Independent Harvesters (crews)
 PIH1 - Producer Crews at Independent Harvesters Tried (crews)
 PIH2 - Maximum Producer Crew Available to Independent Harvesters (crews)
 DT - Solution Time Interval (week)
 ARIH - Adding Rate of Producer Crews at Independent Harvesters (crews/week)

- - - - -

* A negative adding rate is interpreted as a subtracting or releasing rate, and hence drains the level.

** The first-order exponential delay is explained in detail on page 90 of Forrester's Industrial Dynamics (19).

- A - Constant Reflecting Maximum Percentage Increase in Producer Crews Allowed (dimensionless)
- AA - Computational Aid (dimensionless)
- ARIH1 - Adding Rate of Producer Crews Tried at Independent Harvesters (crews/week)
- PPIH - Productivity per Producer Crew at Independent Harvesters (cords/crew/week)
- RIIH - Requisitions Received from Independent Woodyards at Independent Harvesters (cords/week)
- RRDIH - Requisitions Received from Dealer Woodyards at Independent Harvesters (cords/week)
- RRCIH - Requisitions Received from Company Woodyards at Independent Harvesters (cords/week)
- DIFF1 - Difference in Pulpwood Needed Cut and Cutting Capacity at Independent Harvesters (cords/week)
- DAIH - Delay in Adding Producer Crews at Independent Harvesters (weeks)
- PNCIH - Pulpwood Needed Cut at Independent Harvesters (cords/week)
- CCIH - Cutting Capacity at Independent Harvesters (cords/week)

The actual cutting rate at the independent harvesters is equal to the pulpwood needed to be cut or the cutting capacity, whichever is the smallest. This is represented in the model by a clip function.

$$51R \quad CRIH, KL = CLIP(CCIH, K, PNCIH, K, PNCIH, K, CCIH, K)$$

- CRIH - Cutting Rate at Independent Harvesters (cords/week)
- CCIH - Cutting Capacity at Independent Harvesters (cords/week)
- PNCIH - Pulpwood Needed Cut at Independent Harvesters (cords/week)

A complete flow diagram of the independent harvesters sector is shown in Figure 7.

Dealer Harvesters Sector

Basically the dealer harvesters receive all of their orders from the dealer and company woodyards. The unfilled orders at the dealer harvesters are

represented in the model by a level which is filled by the rates of orders received and emptied by the rates of pulpwood shipped from the dealer harvesters. For the purposes of model formulation, separate level equations are used for the orders received from the dealer woodyards and the company woodyards.

$$\begin{aligned}
 1L \quad & UODDH, K=UODDH, J+(DT)(RRDDH, JK-PSDDH, JK) \\
 12N \quad & UODDH=(RRDDH)(DT) \\
 1L \quad & UOCDH, K=UOCDH, J+(DT)(RRC DH, JK-PSCDH, JK) \\
 12N \quad & UOCDH=(RRC DH)(DT) \\
 7A \quad & UODH, K-UODDH, K-UOCDH, K \\
 12A \quad & UNDH, K-(RRDH, K)(DT)
 \end{aligned}$$

- UODDH - Unfilled Orders from Dealer Woodyards at Dealer Harvesters (cords)
 DT - Solution Time Interval (weeks)
 RRDDH - Requisitions Received from Dealer Woodyards at Dealer Harvesters (cords/week)
 PSDDH - Pulpwood Sent to Dealer Woodyards from Dealer Harvesters (cords/week)
 UOCDH - Unfilled Orders from Company Woodyards at Dealer Harvesters (cords)
 RRC DH - Requisitions Received from Company Woodyards at Dealer Harvesters (cords/week)
 PSCDH - Pulpwood Sent to Company Woodyards from Dealer Harvesters (cords/week)
 UODH - Unfilled Orders at Dealer Harvesters (cords)
 UNDH - Unfilled Orders Normal at Dealer Harvesters (cords)

The inventory actual at the dealer harvesters is represented in the model by an accumulation. This accumulation increases by the rate of pulpwood being cut and decreases by the rates of pulpwood being sent to the various woodyards.

$$\begin{aligned}
 52L \quad & IADH, K=IADH, J+(DT)(CRDH, JK-PSDDH, JK-PSCDH, JK+O) \\
 6N \quad & IADH=IDDH
 \end{aligned}$$

- IADH - Inventory Actual at Dealer Harvesters (cords)
 DT - Solution Time Interval (weeks)
 CRDH - Cutting Rate at Dealer Harvesters (cords/week)

- PSDDH - Pulpwood Sent to Dealer Woodyards from Dealer Harvesters (cords/week)
- PSCDH - Pulpwood Sent to Company Woodyards from Dealer Harvesters (cords/week)
- IDDH - Inventory Desired at Dealer Harvesters (cords)

The dealer harvesters do not desire to have a backlog of unfilled orders. They try to fill all orders as soon as they are received. Since there is essentially no handling delay at the dealer harvesters, the rate of shipping is equal to the unfilled orders divided by the solution time interval (the minimum delay allowed by the modeling language). This shipping rate can only be used when there is sufficient wood present in inventory. A clip function is used to ensure that the model does not try to ship more pulpwood than is available. For purposes of model formulation, different shipping functions are used for pulpwood going to the different woodyards.

- 51R PSDDH. $KL = CLIP(STDDH, K, NIDH, K, NIDH, K, STDDH, K)$
- 51R PSCDH. $KL = CLIP(STCDH, K, NCDH, K, NIDH, K, STCDH, K)$
- 20A $STDDH, K = UODDH, K / DT$
- 20A $STCDH, K = UOCDH, K / DT$
- 46A $NDDH, K = (RRDDH, JK)(IADH, K)(1) / ((RRDH, K)(DT)(1))$
- 46A $NCDH, K = (RRC DH, JK)(IADH, K)(1) / ((RRDH, K)(DT)(1))$

- PSDDH - Pulpwood Sent to Dealer Woodyards from Dealer Harvesters (cords/week)
- STDDH - Shipping Rate Tried to Dealer Woodyards from Dealer Harvesters (cords/week)
- NDDH - Negative Inventory Limit Rate to Dealer Woodyards from Dealer Harvesters (cords/week)
- PSCDH - Pulpwood Sent to Company Woodyards from Dealer Harvesters (cords/week)
- STCDH - Shipping Rate Tried to Company Woodyards from Dealer Harvesters (cords/week)
- NCDH - Negative Inventory Limit Rate to Company Woodyards from Dealer Harvesters (cords/week)

- UODDH - Unfilled Orders from Dealer Woodyards at Dealer Harvesters (cords)
- RRDDH - Requisitions Received from Dealer Woodyards at Dealer Harvesters (cords/week)
- IADH - Inventory Actual at Dealer Harvesters (cords)
- RRDH - Total Requisitions Received at Dealer Harvesters (cord/week)
- RRCDDH - Requisitions Received from Company Woodyards at Dealer Harvesters (cords/week)

The dealer harvesters desire to have only a small supply of inventory on hand. They do not want to have any large amounts of cut wood lying idle. The inventory desired is defined as a certain percentage of weekly orders received. For purposes of model formulation, separate desired inventories are defined for the different woodyards for which the dealer harvesters produce.

$$\begin{aligned}
 12A \quad & \text{IDDDH, } K=(\text{RRDDH, } K)(.20) \\
 12A \quad & \text{IDCDH, } K=(\text{RRCDDH, } K)(.20) \\
 7A \quad & \text{IDDH, } K=\text{IDDDH, } K+\text{IDCDH, } K
 \end{aligned}$$

- IDDDH - Inventory Desired for Dealer Woodyards at Dealer Harvesters (cords)
- RRDDH - Requisitions Received from Dealer Woodyards at Dealer Harvesters (cords/week)
- IDCDH - Inventory Desired for Company Woodyards at Dealer Harvesters (cords)
- RRCDDH - Requisitions Received from Company Woodyards at Dealer Harvesters (cords/week)
- IDDH - Total Inventory Desired at Dealer Harvesters (cords)

The rate of pulpwood needed to be cut at the dealer harvesters is based on the unfilled orders, any difference in the desired and actual inventories, and any difference in actual and normal unfilled orders. The difference quantities are divided by the solution time interval to convert them to a weekly rate.

$$25A \quad \text{PNCDH. } K = \text{RRDH. } K + (1/\text{DT})(\text{IDDH. } K - \text{IADH. } K + \text{UODH. } K - \text{UNDH. } K)$$

- PNCDH - Pulpwood Needed to be Cut at Dealer Harvesters (cords/week)
 RRDH - Total Requisitions Received at Dealer Harvesters (cords/week)
 DT - Solution Time Interval (weeks)
 IDDH - Inventory Desired at Dealer Harvesters (cords)
 IADH - Inventory Actual at Dealer Harvesters (cords)
 UODH - Unfilled Orders at Dealer Harvesters (cords)
 UNDH - Unfilled Orders Normal at Dealer Harvesters (cords)

The cutting capacity at the dealer harvesters is determined by multiplying the number of producer crews times the productivity per crew per week at the dealer harvesters. The productivity per crew per week for the dealer harvesters is greater than that of the independent harvesters because the dealer harvesters, on the average, have better harvesting equipment. The dealer harvesters are usually much larger operators and hence have more money to invest in equipment. As more equipment is purchased, the productivity per crew per week can be adjusted to reflect the change.

$$12A \quad \text{CCDH. } K = (\text{PDH. } K)(\text{PPDH})$$

$$C \quad \text{PPDH} = 75$$

- CCDH - Cutting Capacity at Dealer Harvesters (cords/week)
 PDH - Producer Crews at Dealer Harvesters (crews)
 PPDH - Productivity per Producer Crew at Dealer Harvesters (cords/crew/week)

The number of producer crews at the dealer harvesters is represented in the model by a level which is filled and drained by the rate at which producer crews are added. * The rate at which producer crews are added depends upon the difference

- - - - -

* A negative adding rate is interpreted as a subtracting or releasing rate, and hence drains the level.

in the rate of pulpwood needed to be cut and the actual cutting capacity. If the producer crews, working at capacity, cannot produce at the rate needed, more crews are added. If the producer crews are producing at the rate needed but are not working at capacity, some crews are released. The increase in crews added is limited to a maximum increase of 30 per cent. The rate of adding crews is represented as a first-order exponential delay. The delay constant for adding crews is taken to be six weeks. The rate of adding crews at the dealer harvesters is limited to a maximum of one crew per week.

54A $PDH.K = \text{MIN}(PDH1.K, PDH2)$
 1L $PDH1.K = PDH.J + (DT)(ARDH.JK + O)$
 24N $PDH1 = (1/PPDH)(RRDDH + RRC DH + O + O + O + O)$
 46A $PDH2.K = (A)(3100)(BB.K / ((PPDH)(1)(1))$
 C $A = 1.30$
 15A $BB.K = (DWP)(DHDP) - (CWP)(DHCP)$
 54R $ARDH = \text{MIN}(ARDH1.JK, 1)$
 42R $ARDH1.KL = \text{DIFF}2.K / ((PPDH)(DADH))$
 C $DADH = 6$
 7A $\text{DIFF}2.K = \text{PNCDH}.K - \text{CCDH}.K$

PDH - Producer Crews at Dealer Harvesters (crews)
 PDH1 - Producer Crews Needed at Dealer Harvesters (crews)
 PIH2 - Maximum Producer Crews Available to Dealer Harvesters (crews)
 DT - Solution Time Interval (weeks)
 ARDH - Adding Rate of Producer Crews at Dealer Harvesters (crews/week)
 A - Constant Reflecting Maximum Percentage Increase in Producer Crews Allowed (dimensionless)
 BB - Computational Aid (dimensionless)
 ARDH1 - Adding Rate of Producer Crews Tried at Dealer Harvesters (crews/week)
 PPDH - Productivity per Producer Crews at Dealer Harvesters (cords/crew/week)
 PRDDH - Requisitions Received from Dealer Woodyards at Dealer Harvesters (cords/week)
 RRC DH - Requisitions Received from Company Woodyards at Dealer Harvesters (cords/week)

- DIFF2 - Difference in Pulpwood Needed Cut and Cutting Capacity at Dealer Harvesters (cords/week)
 DADH - Delay in Adding Producer Crews at Dealer Harvesters (weeks)
 PNCDH - Pulpwood Needed Cut at Dealer Harvesters (cords/week)
 CCDH - Cutting Capacity at Dealer Harvesters (cords/week)

The actual cutting rate at the dealer harvesters is equal to the pulpwood needed to be cut or the cutting capacity, whichever is the smallest. This is represented in the model by a clip function.

$$51R \quad CRDH.KL = CLIP(CCDH.K, PNCDH.K, PNCDH.K, CCDH.K)$$

- CRDH - Cutting Rate at Dealer Harvesters (cords/week)
 CCDH - Cutting Capacity at Dealer Harvesters (cords/week)
 PNCDH - Pulpwood Needed Cut at Dealer Harvesters (cords/week)

A complete flow diagram of the dealer harvesters sector is shown in Figure 8.

Company Harvesters Sector

The company harvesters produce only for the company woodyards. Usually, the company harvesters are the most efficient of the three classes of harvesters. This is because they are affiliated with the company and have company finances backing them.

The unfilled orders at the company harvesters are represented in the model by a level which is filled by the rate of orders received and depleted by the rate of pulpwood shipped.

$$1L \quad UOCCH.K = UOCCH.J + (DT)(RRCCH.JK - PSCCH.JK)$$

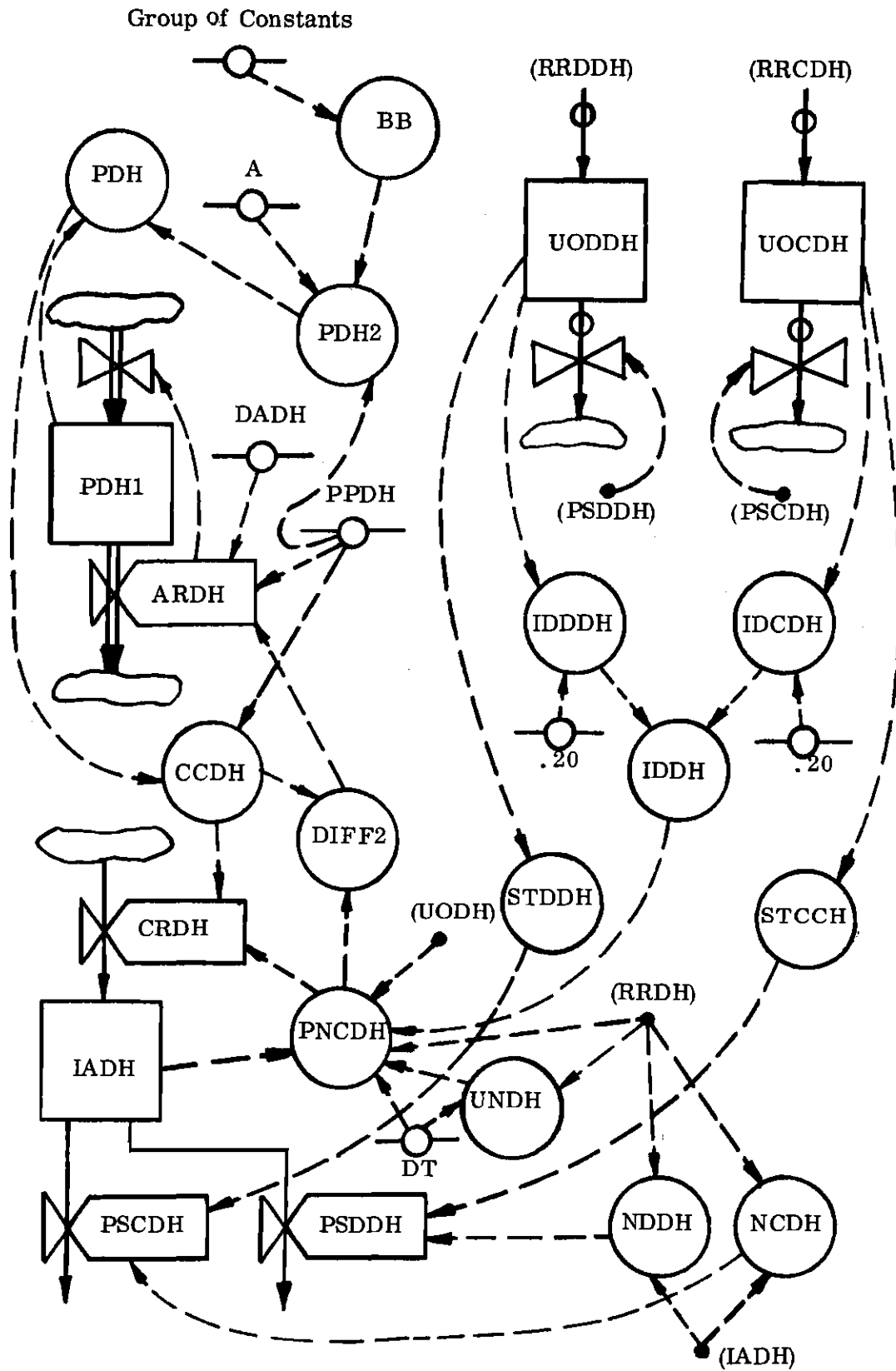

Figure 8. Flow Diagram of Dealer Harvesters Sector.

$$12N \quad UOCCH=(RRCCH)(DT)$$

$$12A \quad UNCH, K=(RRCCH, JK)(DT)$$

- UOCCH - Unfilled Orders from Company Woodyards at Company Harvesters (cords)
- DT - Solution Time Interval (weeks)
- RRCCH - Requisitions Received from Company Woodyards at Company Harvesters (cords/week)
- PSCCH - Pulpwood Sent to Company Woodyards from Company Harvesters (cords/week)
- UNCH - Unfilled Orders Normal at Company Harvesters (cords)

The inventory actual at the company harvesters is defined as a level which is filled by the rate of pulpwood being cut and is emptied by the rate of pulpwood sent to the company woodyards.

$$1L \quad IACH, K=IACH, J+(DT)(CRCH, JK-PSCCH, JK)$$

$$6N \quad IACH=IDCH$$

- IACH - Inventory Actual at Company Harvesters (cords)
- DT - Solution Time Interval (weeks)
- CRCH - Cutting Rate at Company Harvesters (cords/week)
- PSCCH - Pulpwood Sent to Company Woodyards from Company Harvesters (cords/week)

Like the independent and dealer harvesters, the company harvesters have no noticeable delay in handling an order. Thus, the shipping rate tried is equal to the unfilled orders divided by the solution time interval (the minimum delay allowed by the modeling language). To ensure that the model does not attempt to ship more pulpwood than is present in inventory, a clip function is utilized.

$$51R \quad PSCCH, KL=CLIP(STCH, K, NICH, K, NICH, K, STCH, K)$$

$$20A \quad STCH, K=UOCCH, K/DT$$

$$20A \quad NICH, K=IACH, K/DT$$

- PSCCH - Pulpwood Sent to Company Woodyards from Company Harvesters (cords/week)

- STCH - Shipping Rate Tried at Company Harvesters (cords/week)
- NICH - Negative Inventory Limit Rate at Company Harvesters (cords/week)
- UOCCH - Unfilled Orders from Company Woodyards to Company Harvesters (cords)
- DT - Solution Time Interval (weeks)
- IACH - Inventory Actual at Company Harvesters (cords)

The inventory desired at the company harvesters is small. Like the dealer harvesters, the company harvesters do not want a large supply of unsold wood on hand. The inventory desired is defined in the model as a small percentage of weekly orders.

$$12A \quad IDCH.K = (RRCCH.K) (.20)$$

- IDCH - Inventory Desired at Company Harvesters (cords)
- RRCCH - Requisitions Received from Company Woodyards at Company Harvesters (cords/week)

Desiring not to have a backlog of unfilled orders, the company woodyards need to cut at a rate large enough to fill all unfilled orders, balance desired and actual inventories, and balance actual and normal unfilled orders. The unfilled orders and the difference in desired and actual inventories are divided by the solution time interval to convert the output to a weekly rate.

$$25A \quad PNCCH.K = RRCCH.K + (1/DT)(IDCH.K - IACH.K + UOCCH.K - UNCH.K)$$

- PNCCH - Pulpwood Needed Cut at Company Harvesters (cords/week)
- RRCCH - Requisitions Received from Company Woodyards at Company Harvesters (cords/week)
- DT - Solution Time Interval (weeks)
- IDCH - Inventory Desired at Company Harvesters (cords)
- IACH - Inventory Actual at Company Harvesters (cords)
- UOCCH - Unfilled Orders from Company Woodyards at Company Harvesters (cords)

UNCH - Unfilled Orders Normal at Company Harvesters (cords)

The cutting capacity at the company harvesters is determined by multiplying the number of producer crews times the productivity per crew per week. The productivity per crew per week for the company harvesters is higher than that for both the independent and dealer harvester. Because of financial support from the mill, the company harvesters can better afford the latest harvesting equipment. This is reflected in the model by a higher constant for productivity per crew per week. As more equipment is put into use this constant can easily be adjusted.

$$12A \quad CCCH, K=(PCH, K)(PPCH)$$

$$C \quad PPCH=100$$

CCCH - Cutting Capacity at Company Harvesters (cords/week)
 PCH - Producer Crews at Company Harvesters (men)
 PPCH - Productivity per Producer Crew at Company Harvesters
 (cords/man/week)

The number of producer crews at the dealer harvesters is represented in the model by an accumulation. This accumulation is filled and drained by the rate at which producer crews are added.* The rate at which producer crews are added depends on the difference in the pulpwood needed to be cut and the actual cutting capacity. If the producer crews, working at capacity, cannot produce at the rate needed, more crews are added. If the producer crews are producing at the rate needed but are not working at capacity, some crews are released. The increase in crews added is limited to a maximum increase of 30 per cent. The rate of

- - - - -

* A negative adding rate is interpreted as a subtracting or releasing rate, and hence drains the accumulation.

adding crews is represented by a first-order exponential delay with the delay constant equal to six weeks. The rate of adding producer crews at the company harvesters is limited to a maximum of one crew per week.

```

54A  PCH. K=MIN(PCH1. K, PCH2)
1L   PCH1. K=PCH. J+(DT)(ARCH. JK+O)
21N  PCH1=(1/PPCH)(RRCCH+O)
46A  PCH2. K=(A)(3100)(CC. K)/(PPCH)(1)(1)
C    A=1.30
12A  CC. K=(CWP)(CHCP)
54A  ARCH. KL=MIN(ARCH1. JK, 1)
42R  ARCH1. KL=DIF3. K/((PPCH)(DACH))
C    DACH=6
7A   DIF3. K=PNCCH. K-CCCH. K

```

PCH - Producer Crews at Company Harvesters (crews)
PCH1 - Producer Crews Needed at Company Harvesters (crews)
PCH2 - Maximum Producer Crews Available to Company Harvesters (crews)
DT - Solution Time Interval (weeks)
ARCH - Adding Rate of Producer Crew at Company Harvesters (cords/week)
A - Constant Reflecting Maximum Percentage Increase in Producer Crews Allowed (dimensionless)
BB - Computational Aid (dimensionless)
ARCH1 - Adding Rate of Producer Crews Tried at Company Harvesters (crews/week)
PPCH - Productivity per Producer Crew per Week at Company Harvesters (cords/crew/week)
RRCCH - Requisitions Received from Company Woodyards at Company Harvesters (cords/week)
DIF3 - Difference in Pulpwood Needed Cut and Cutting Capacity at Company Harvesters (cords/week)
DACH - Delay in Adding Producer Crews at Company Harvesters (week)
PNCCH - Pulp Needed Cut at Company Harvesters (cords/week)
CCCH - Cutting Capacity at Company Harvesters (cords/week)

The actual cutting rate at the company harvesters is equal to the pulpwood needed to be cut or the cutting capacity, whichever is the smallest.

51R CRCH.KL=CLIP(CCCH.K, PNCCH.K, PNCCH.K, CCCH.K)

CRCH - Cutting Rate at Company Harvesters (cords/week)
CCCH - Cutting Capacity at Company Harvester (cords/week)
PNCCH - Pulpwood Needed Cut at Company Harvester (cords/week)

A flow diagram of the company harvesters sector is shown in Figure 9.

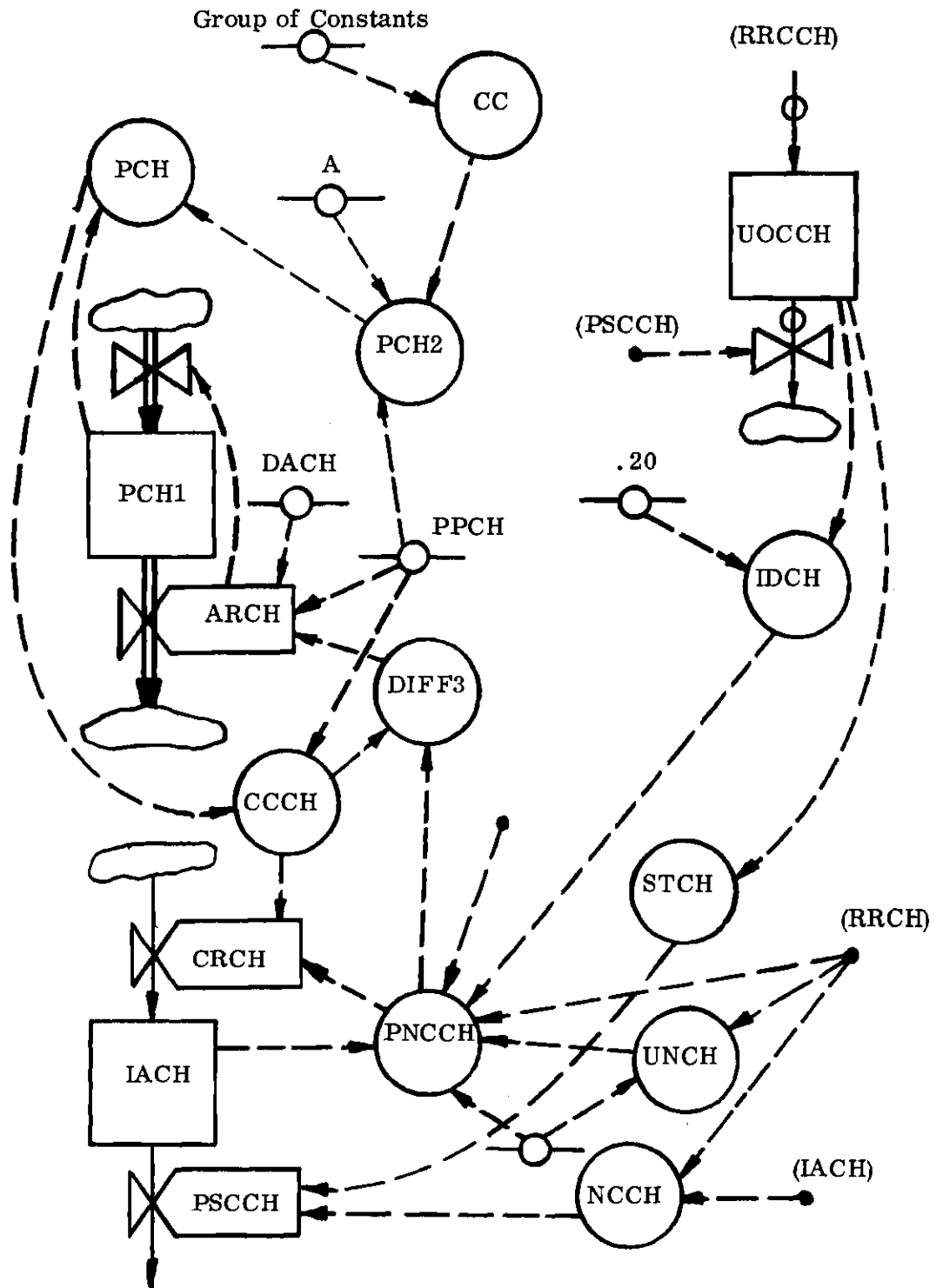

Figure 9. Flow Diagram of Company Harvesters Sector.

CHAPTER V

MODEL EXPERIMENTS

The model was run using four different driving functions. Eighteen different parameter value combinations were used for each of the four different driving functions. This made a total of 72 different simulation experiments.

Driving Functions Used

The first driving function used showed no change in the orders received at the mill. This was accomplished through the following equations:

$$\begin{array}{ll} 7R & \text{ORM. KL}=\text{ORMN}+\text{OCM. K} \\ C & \text{ORMN}=3100 \\ 6A & \text{OCM. K}=0 \end{array}$$

ORM - Orders Received at Mill (cords/week)
 ORMN - Orders Received at Mill, Normal (cords/week)
 OCM - Order Change at Mill (cords/week)

The second driving function used was the "ramp function." A ramp function gradually increases the input by a certain specified amount. It was decided to constantly increase the orders received at the mill such that a 15 per cent increase would be realized by week 26. At week 26, the orders were to level off. An increase of 17.8 cords per week for the first 26 weeks would give a 15 per cent increase by week 26. This desired increase in consumption was accomplished through the following equations.

51A OCM, K=CLIP(465, DD, K, TIME, K, 26)
 47A DD, K=RAMP(17.8, 1)

OCM - Order Change at Mill (cords/week)
 DD - Ramp Function (cords/week)
 TIME - Calendar Time Measured in Weeks (automatically
 generated and available from the DYNAMO compiler).

The third driving function used was a "step function." This is a sudden disturbance caused by changing an external system input to some new value that is then held constant. A step function is a shock containing, in principle, an infinite band of component frequencies. It can serve to "excite" any mode of response that may be inherent in the system model being tested. If the system has oscillatory behavior, the step input gives an immediate indication of the natural period of oscillation and the rapidity of damping or of growth of the oscillation. The step input will also serve to trigger any cumulative tendencies toward sustained growth or decline. The step function was incorporated into the model by using the following equation:

45A OCM, K=STEP(465, 1)

OCM - Order Change at Mill (cords/week)

The fourth driving function used was the "sine function." This is a function which sinusoidally varies the input. The response of a system to sinusoidal inputs is highly informative in showing system characteristics. It was decided to use a sinusoidal disturbance with a one-year period and an amplitude equal to 15 per cent of the orders normally received at the mill. This change in orders received at the mill was accomplished through the use of the following equation:

31A OCM. K=(465)SIN((2PI)(TIME. K)/52)

OCM - Order Change at Mill (cords/week)
 TIME Calendar Time Measured in Weeks (automatically
 generated and available from the DYNAMO compiler).

Parameter Combinations Tested

Three basic parameter values were varied in the experiments. The basic parameters varied were the total percentages of wood harvested by each classification of harvesters, the availability of labor, and the productivities per crew for each classification of harvesters. Three different sets of values were tested for each of the first two parameters mentioned above. Two sets of values were tested for the latter parameter. This made a total of 18 different combinations tested.*

The percentages of wood harvested by the different classifications of harvesters were changed so the independent harvesters cut three per cent, 30 per cent, and 60 per cent of all wood harvested. At corresponding times the company harvesters cut 60 per cent, 30 per cent, and three per cent of all wood harvested. The dealers' percentages of total wood harvested were adjusted to give the desired independent and company percentages. The labor availability was tested allowing a 30 per cent maximum increase in total labor (representing virtually an unlimited system), a 20 per cent maximum increase in total labor, and a ten per cent maximum increase in total labor. The productivity rates for each of the classifications of harvesters were first tested as formulated in Chapter IV. Then the respective productivity rates were each doubled and tested

- - - - -

* From combinatorial mathematics: $3 \times 3 \times 2 = 18$

again. These productivity rate increases represent great improvements in equipment and harvesting methods. Table 1 outlined the eighteen different parameter combinations tested for each of the four driving functions. The run numbers referred to throughout this chapter will correspond to the associated parameter values given in Table 1.

Results of Experiments

All experiments presented in this section were run for a period of two years. The results are reported on the system responses during this two years.

Zero Consumption Change Experiments

The results of experimentation with no consumption changes (representing steady-state conditions) yielded the least information of the four driving functions tested. However, these experiments did point out two important characteristics of the system. Because there was no change in the mill consumption rates, the results were the same for all three labor availability situations. This is because any labor fluctuations created internally were never greater than ten per cent. The two important characteristics brought out by these experiments were the lag times between the actual mill inventory and desired mill inventory and the time first required for actual mill inventory to equal desired mill inventory. Again because of no change in the mill consumption rates, the mill inventory did not fluctuate greatly in any of these experiments. The results of the lag times and time required for actual mill inventory to equal desired mill inventory are shown in Table 2.

Analyzing Table 2 one observes that the lag and required times do decrease

Table 1. Parameter Values Associated With Run Numbers

Run	Percentage of Total Wood Harvested by Independent	Labor Availability	Respective Productivity Rates for Independent, Dealer, and Company Harvesters
1	60	1.30	25, 75, 100
2	30	1.30	25, 75, 100
3	3	1.30	25, 75, 100
4	60	1.30	50, 150, 200
5	30	1.30	50, 150, 200
6	3	1.30	50, 150, 200
7	60	1.20	25, 75, 100
8	30	1.20	25, 75, 100
9	3	1.20	25, 75, 100
10	60	1.20	50, 150, 200
11	30	1.20	50, 150, 200
12	3	1.20	50, 150, 200
13	60	1.10	25, 75, 100
14	30	1.10	25, 75, 100
15	3	1.10	25, 75, 100
16	60	1.10	50, 150, 200
17	30	1.10	50, 150, 200
18	3	1.10	50, 150, 200

Table 2. Significant Results of Zero Consumption Change Experiments

Run	Weeks Lag Between Actual Mill Inventory and Desired Mill Inventory	Weeks Required for Mill Inventory to Equal Desired Mill Inventory
1	8	19
2	8	18
3	7	18
4	7	18
5	7	18
6	6	18
7	8	19
8	8	18
9	7	18
10	7	18
11	7	18
12	6	18
13	8	19
14	8	18
15	7	18
16	7	18
17	7	18
18	6	18

slightly as one decreases the percentage of wood harvested by the independent harvesters. This is also true as the respective productivity rates are doubled. The real effects of these decreases in lag times and required times will be brought out in later experiments.

Ramp Function Experiments

As outlined previously, a ramp increase in mill consumption of 17.8 cords per week was realized until week 26. At week 26 the mill consumption leveled off to a constant rate. Table 3 shows the weeks required for actual mill inventory to equal desired mill inventory, the weeks required for the system to return to equilibrium, and the lowest inventory realized at the mill.

Analyzing Table 3 one can observe that the inventory at the mill never fell by appreciable amounts. Also the weeks required for actual mill inventory to equal desired mill inventory were almost exactly the same for the first 12 runs. The same is true of the weeks required for the system to return to equilibrium. In runs 12 through 18 the actual mill inventory gradually goes to zero because the mill consumption increases 15 per cent in six months, but labor is limited to a ten per cent increase. The system does react very well to a gradual increase in mill consumption.

Step Function Experiments

A 15 per cent step increase in mill consumption was realized at time period one. The consumption rate maintained this new level throughout the step function experiments. The significant results of these experiments are shown in Table 4.

Table 3. Significant Results of Experimentation With Ramp Function

Run	Weeks Required for Actual Mill Inventory to Equal Desired Mill Inventory	Weeks Required for System to Return to Equilibrium	Minimum Inventory Realized (cords)
1	32	48	6100
2	32	48	6100
3	32	48	6100
4	32	48	6100
5	32	48	6100
6	32	48	6100
7	32	48	6100
8	32	48	6100
9	32	48	6100
10	32	48	6100
11	32	48	6100
12	32	48	6100
13	∞	∞	0
14	∞	∞	0
15	∞	∞	0
16	∞	∞	0
17	∞	∞	0
18	∞	∞	0

Table 4. Significant Results of Experimentation With Step Function

Run	Weeks Required for Actual Mill Inventory to Equal Desired Mill Inventory	Weeks Required for System to Return to Equilibrium	Minimum Inventory Realized (cords)
1	28	52	5300
2	20	48	5400
3	19	47	5500
4	19	46	5500
5	18	44	5500
6	18	44	5500
7	44	90	5400
8	24	44	5500
9	18	42	5500
10	28	54	5300
11	20	44	5500
12	18	42	5500
13	∞	∞	0
14	∞	∞	0
15	∞	∞	0
16	∞	∞	0
17	∞	∞	0
18	∞	∞	0

Analyzing the first three runs, one observes a significant decrease in the weeks required for the actual and desired inventories to become equal as one decreases the independent harvesting operations from 60 to 30 per cent. * However, there is little change as one decreases the independent harvesting operations from 30 to three per cent. The weeks required for the system to return to equilibrium are different by four and five weeks respectively for the first three runs.

Analyzing the second three runs one observes that as the productivity rates are doubled, the weeks required for the actual and desired inventories to be equal are less but not by a large factor. The same is true of the weeks required for the systems to reach equilibrium. Also, as the productivity rates are doubled, the differences between the 60 per cent and the 30 per cent independent harvesting systems become insignificant.

The third three runs, which are run with a maximum labor increase of 20 per cent, show very large differences in reaction times as one decreases the independent harvesting operations. Under this labor situation, it is extremely beneficial to move toward larger company operations because the system with 30 percent of all harvesting by company crews reacts almost twice as fast as the system with three per cent of all harvesting by company crews.

The fourth three runs, with maximum labor increases of 20 per cent and doubled productivity rates, show similar results with the first three runs. Large

- - - - -

* This increases the company operations from three to 30 per cent. Throughout this chapter, any decrease in independent harvesting operations represents the same increase in company harvesting operations.

differences in reaction times occur as the independent harvesting operations are decreased from 60 to 30 per cent. Much smaller differences in reaction times occur as the independent harvesting operations are further reduced from 30 to three per cent.

In runs 13 through 18 the system never reaches equilibrium because the labor increase is limited to a ten per cent increase. Thus, the actual inventory at the mill eventually goes to zero.

Sine Function Experiments

A sinusoidal fluctuation in the mill orders produced very interesting results. The amplitude of the variation was 15 per cent of the initial mill orders. The period of the sinusoidal fluctuation was one year. The significant results of the sine function experiments are exhibited in Table 5.

An analysis of the first three runs shows extreme differences in these runs. Run 1, with independent harvesting operating totalling 60 per cent, the entire system was found to be rapidly exploding.* Both inventories and labor showed extreme fluctuations. By decreasing the independent harvesters total operations to 30 per cent the system was found to explode but at a much slower rate. By further decreasing the independent harvesters total operations to three per cent in run 3, the system became stable. Run 3 showed only small fluctuations in inventories and labor.

The second three runs reflect the effects of doubling the productivity rates of the respective harvesters. The increased productivity rates slowed down the

- - - - -

* Recall that the reported results are for two year system responses; thus the system was rapidly exploding for the two years which it was tested.

Table 5. Significant Results of Experimentation With Sine Function

Run	General Type of System Behavior	High Mill Inventory Point (cords)	Low Mill Inventory Point (cords)
1	Rapidly Explosive	17,000	1,000
2	Gradually Explosive	8,000	4,500
3	Not Explosive	7,800	4,600
4	Gradually Explosive	12,000	4,000
5	Not Explosive	7,800	4,600
6	Not Explosive	7,800	4,600
7	Rapidly Explosive	15,000	0
8	Gradually Explosive	9,000	4,000
9	Not Explosive	7,800	4,600
10	Gradually Explosive	20,000	3,500
11	Not Explosive	7,800	4,600
12	Not Explosive	7,800	4,600
13	Rapidly Explosive	12,000	0
14	Gradually Explosive	12,000	4,000
15	Gradually Explosive	11,000	4,600
16	Rapidly Explosive	13,000	2,500
17	Gradually Explosive	11,000	4,800
18	Gradually Explosive	11,000	4,800

explosiveness earlier exhibited by the system with 60 per cent independent harvesting operations. The 30 per cent independent harvesting system was completely dumped from all explosiveness. Very little difference was found between the 30 per cent independent harvesting system and the three per cent independent harvesting system.

By limiting the producer crews to a 20 per cent increase, the third three runs show the effects of tightening the labor situation. The results were very similar to the first three runs. The system with 60 per cent independent harvesting operations was quite explosive. The system with 30 per cent independent harvesting operations was less explosive. The three per cent independent harvesting system was not explosive and showed small inventory and labor fluctuations.

The fourth three runs, with maximum labor increases of 20 per cent and doubled productivity rates, did not differ greatly from the second three runs, which were run with identical parameter values except for the limit on labor increases. The inventory fluctuations varied insignificantly from the second three runs.

Runs 13 through 15, which limited labor increases to ten per cent, revealed some interesting results. The mill inventory of the system with 60 per cent independent harvesting operations was depleted to zero at week 70. The mill inventory in the 30 per cent independent harvesting system never fell below 4,000 cords. The system with three per cent independent harvesting operations produced results analogous to the system with 30 per cent independent harvesting operations.

Runs 16 through 18, with maximum labor increases of ten per cent and

doubled productivity rates, reflected results similar to Runs 13 through 15. The only significant difference was that the mill inventory of the system with 60 per cent independent harvesting operations did not reach zero.

CHAPTER VI

CONCLUSIONS AND RECOMMENDATIONS

Conclusions

The model experiments presented in the preceding chapter led the author to several conclusions concerning the present pulpwood procurement system. These conclusions are summarized below.

- (1) The present system does react well to gradual increases in mill consumption.
- (2) The present system does not react adequately to sudden or unexpected increases in mill consumption.
- (3) Fluctuating increases and decreases in mill consumption will cause the system to get progressively out of control.
- (4) Decreasing the total independent harvesting operations from 60 per cent to 30 per cent, while increasing the total company harvesting operations from three per cent to 30 per cent, allows the overall system to react at a much faster rate.
- (5) Further decreasing the total independent harvesting operations from 30 per cent to three per cent, while increasing the total company harvesting operations from 30 per cent to 60 per cent, does not cause the system to react at an appreciably faster rate under most circumstances.
- (6) Increasing the productivity rates of the producers has a much larger

effect on systems with large independent harvesting operations than systems with small independent harvesting operations.

(7) Systems which allow maximum labor increases of ten to 20 per cent react much slower than do systems which have maximum labor increase of up to 30 per cent.

(8) The overall system, regardless of the labor situation, can singularly best be improved by decreasing the independent harvesting operations to around 30 per cent while increasing the company harvesting operations to around 30 per cent.

(9) Simultaneously decreasing the percentage of independent harvesting operations and increasing the producer productivity rates can best improve the control of the system. That is to say that, in addition to decreasing the percentage of independent harvesting operations, any increases in the producer productivity rates will further improve system control.

Recommendations

It must be realized that the model as presented in Chapter IV and as experimented with in Chapter V were run for the general case in order to determine overall industry trends. Thus "best averages" and "best estimates" were used in determining the constants used in the model.

It is strongly recommended that individual mills experiment with the model using their individual mill data. In this way individual mills can study their particular system and not the average system. The individual mills can determine the exact mill-harvester relationships desired for each individual mill. Also, the

effects of increasing the producers' productivity rates can be determined precisely for each individual mill.

It is felt that the model presented in this thesis can provide the pulpwood industry with much additional information if used by the individual mills as outlined above. The range of experiments the model is capable of performing is unlimited except for money flow experiments. No money flow network was included in the model. In view of the decision sought, the experiments of this research were limited to varying the percentages of wood harvested by the independent and company harvesters, varying the labor situation, and varying the producer productivity rates. However, any physical segment of the present system can be experimented with.

The research presented in this thesis sought only to investigate the most desirable mill-harvester relationships. No attention was given to the cost of obtaining these desired relationships and results. It is specifically recommended that further research be carried out concerning the costs required to obtain these results. It is felt that a money flow network could readily be incorporated into the model presented in this thesis. Once a money flow network has been properly incorporated into the model, experiments could be performed to determine the net values to be gained by introducing the desired changes in the system.

APPENDIX
MODEL FORMULATION PRINTOUT

```

5* 0001 001,DYN,TEST,2,4,0,0 IND DYNA TEST MODEL BY L W RUE
RUN
NOTE
NOTE MILL PROCUREMENT SECTOR
7R ORM.KL=ORMN*OCM.K
C ORMN=3100
31A OCM.K=(465)SIN((2PI)*(TIME.K)/52)
52L IAM.K=IAM.J+(DT)*(PRCM.JK+PRDM.JK+PRIM.JK-SSM.JK) INV ACT AT MILL
6N IAM=IDM
1L UOM.K=UOM.J+(DT)*(ORM.JK-SSM.JK)
12N UOM=(ORM)*(DHM)
12A UNM.K=(ORM.JK)*(DHM)
20A STM.K=UOM.K/DHM
C DHM=1.4
20A NIM.K=IAM.K/DT
51R SSM.KL=CLIP(STM.K,NIM.K,NIM.K,STM.K)
7A IDM.K=IDNM.K-SIC.K
12A IDNM.K=(ORM.JK)*(2)
31A SIC.K=(AM.K)SIN((2PI)*(TIME.K)/52)
12A AM.K=(ORM.K)*(10)
25R ODM.KL=ORM.JK+(1/DIM)*(IDM.K-IAM.K+UOM.K-UNM.K+0.0)
C DIM=8
52L TOSM.K=TOSM.J+(DT)*(ODM.JK-OSIM.JK-OSDM.JK-OSCM.JK) TOT ORD BY MILL
6N TOSM=ORM
12R OSIM.KL=(IWP)*(TOSM.K)
C IWP=.03
12R OSDM.KL=(DWP)*(TOSM.K)
C DWP=.37
12R OSCM.KL=(CWP)*(TOSM.K)
C CWP=.60
1L CPIM.K=CPIM.J+(DT)*(OSIM.JK-RRIW.JK)
12N CPIM=(TOSM)*(IWP)*(DCIM)
1L CPDM.K=CPDM.J+(DT)*(OSDM.JK-RRDW.JK)
12N CPDM=(TOSM)*(DWP)*(DCDM)
1L CPCM.K=CPCM.J+(DT)*(OSCM.JK-RRCW.JK)
12N CPCM=(TOSM)*(CWP)*(DCCM)
39R RRIW.KL=DELAY3(OSIM.JK,DCIM)
C DCIM=1
39R RRDW.KL=DELAY3(OSDM.JK,DCDM)
C DCDM=1
39R RRCW.KL=DELAY3(OSCM.JK,DCCM)
C DCCM=.5
1L PTIM.K=PTIM.J+(DT)*(PSIW.JK-PRIM.JK)
12N PTIM=(TOSM)*(IWP)*(DTIM)
1L PTDM.K=PTDM.J+(DT)*(PSDW.JK-PRDM.JK)
12N PTDM=(TOSM)*(DWP)*(DTDM)
1L PTCM.K=PTCM.J+(DT)*(PSCW.JK-PRCM.JK)
12N PTCM=(TOSM)*(CWP)*(DTCM)
39R PRIM.KL=DELAY3(PSIW.JK,DTIM)
C DTIM=2
39R PRDM.KL=DELAY3(PSDW.JK,DTDM)
C DTDM=1
39R PRCM.KL=DELAY3(PSCW.JK,DTCM)
C DTCM=1
NOTE
NOTE INDEPENDENT WOODYARDS SECTOR
1L UOIW.K=UOIW.J+(DT)*(RRIW.JK-PSIW.JK)
12N UOIW=(RRIW)*(DHIW)
12A UNIW.K=(RRIW)*(DHIW)
1L IAIW.K=IAIW.J+(DT)*(PRIIW.JK-PSIW.JK)
6N IAIW=IDIW
20A STIW.K=UOIW.K/DHIW
C DHIW=1

```

```

20A NIIW.K=IAIW.K/DT
51R PSIW.KL=CLIP(STIW.K,NIIW.K,NIIW.K,STIW.K)
12A IDIW.K=(AIW)(RRIW.K)
C AIW=.5
C MIIW=100
25R ODIW.KL=RRIW.JK+(1/DIIW)(IDIW.K-IAIW.K+UOIW.K-UNIW.K+0+0)
C DIIW=6
1L PTIW.K=PTIW.J+(DT)(PSIIH.JK-PRIIW.JK)
12N PTIW=(RRIW)(DTIW)
39R PRIIW.KL=DELAY3(PSIIH.JK,DTIW)
C DTIW=.3
1L CPIW.K=CPIW.J+(DT)(ODIW.JK-RRIIH.JK)
12N CPIW=(RRIW)(DCIW)
39R RRIIH.KL=DELAY3(ODIW.JK,DCIW)
C DCIW=1
NOTE
NOTE DEALER WOODYARDS SECTOR
1L UODW.K=UODW.J+(DT)(RRDW.JK-PSDW.JK)
12N UODW=(RRDW)(DHDW)
12A UNDW.K=(RRDW.K)(DHDW)
52L IADW.K=IADW.J+(DT)(PRIDW.JK+PRDDW.JK-PSDW.JK+0) INV ACT AT IW
6N IADW=IDDW
20A STDW.K=UODW.K/DHDW
C DHDW=1
20A NIDW.K=IADW.K/DT
12A IDDW.K=(ADW)(RRDW.K)
C ADW=.5
C MIDW=600
51R PSDW.KL=CLIP(STDW.K,NIDW.K,NIDW.K,STDW.K)
1L PTIDW.K=PTIDW.J+(DT)(PSDIH.JK-PRIDW.JK)
13N PTIDW=(RRDW)(IHDP)(DTDIH)
39R PRIDW.KL=DELAY3(PSDIH.JK,DTDIH)
1L PTDDW.K=PTDDW.J+(DT)(PSDDH.JK-PRDDW.JK)
C DTDIH=.3
13N PTDDW=(RRDW)(DHDP)(DTDDH)
39R PRDDW.KL=DELAY3(PSDDH.JK,DTDDH)
C DTDDH=.3
25R ODDW.KL=RRDW.JK+(1/DIDW)(IDDW.K-IADW.K+UODW.K-UNDW.K+0+0)
C DIDW=6
52L TOSDW.K=TOSDW.J+(DT)(ODDW.JK-OSIDW.JK-OSDDW.JK+0) TOT ORD FR DW
6N TOSDW=RRDW
12R OSIDW.KL=(IHDP)(TOSDW.K)
C IHDP=.40
12R OSDDW.KL=(DHDP)(TOSDW.K)
C DHDP=.60
1L CPIDW.K=CPIDW.J+(DT)(OSIDW.JK-RRDIH.JK)
13N CPIDW=(RRDW)(IHDP)(DCIDW)
39R RRDIH.KL=DELAY3(OSIDW.JK,DCIDW)
C DCIDW=1
1L CPDDW.K=CPDDW.J+(DT)(OSDDW.JK-RRDDH.JK)
13N CPDDW=(RRDW)(DHDP)(DCDDW)
39R RRDDH.KL=DELAY3(OSDDW.JK,DCDDW)
C DCDDW=1
NOTE
NOTE COMPANY WOODYARDS SECTOR
1L UOCW.K=UOCW.J+(DT)(RRCW.JK-PSCW.JK)
12N UOCW=(RRCW)(DHCW)
12A UNCW.K=(RRCW.K)(DHCW)
52L IACW.K=IACW.J+(DT)(PRICW.JK+PRDCW.JK+PRCCW.JK-PSCW.JK) INV ACT CI
6N IACW=IDCW
20A STCW.K=UOCW.K/DHCW
C DHCW=.5
20A NICW.K=IACW.K/DT

```

```

51R PSCW.KL=CLIP(STCW.K,NICW.K,NICW.K,STCW.K)
12A IDCW.K=(ACW)(RRCW.K)
C ACW=.5
C MICW=900
1L PTICW.K=PTICW.J+(DT)(PSCIH.JK-PRICW.JK)
13N PTICW=(RRCW)(IHCP)(DTCIH)
39R PRICW.KL=DELAY3(PSCIH.JK,DTCIH)
C DTCIH=.3
1L PTDCW.K=PTDCW.J+(DT)(PSCDH.JK-PRDCW.JK)
13N PTDCW=(RRCW)(DHCP)(DTCDH)
39R PRDCW.KL=DELAY3(PSCDH.JK,DTCDH)
C DTCDH=.3
1L PTCCW.K=PTCCW.J+(DT)(PSCCH.JK-PRCCW.JK)
13N PTCCW=(RRCW)(CHCP)(DTCCH)
39R PRCCW.KL=DELAY3(PSCCH.JK,DTCCH)
C DTCCH=.3
25R ODCW.KL=RRCW.JK+(1/DICW)(IDCW.K-IAEW.K+UOCW.K-UNEW.K+0+0)
C DICW=6
52L TOSCW.K=TOSCW.J+(DT)(ODCW.JK-OSICW.JK-OSDCW.JK-OSCCW.JK) TOT O CW
6N TOSCW=RRCW
12R OSICW.KL=(IHCP)(TOSCW.K)
C IHCP=.70
12R OSDCW.KL=(DHCP)(TOSCW.K)
C DHCP=.25
12R OSCCW.KL=(CHCP)(TOSCW.K)
C CHCP=.05
1L CPICW.K=CPICW.J+(DT)(OSICW.JK-RRCIH.JK)
13N CPICW=(RRCW)(IHCP)(DCICW)
39R RRCIH.KL=DELAY3(OSICW.JK,DCICW)
C DCICW=1
1L CPDCW.K=CPDCW.J+(DT)(OSDCW.JK-RRCDH.JK)
13N CPDCW=(RRCW)(DHCP)(DCDCW)
39R RRCDH.KL=DELAY3(OSDCW.JK,DCDCW)
C DCDCW=1
1L CPCCW.K=CPCCW.J+(DT)(OSCCW.JK-RRCCH.JK)
13N CPCCW=(RRCW)(CHCP)(DCCCW)
39R RRCCH.KL=DELAY3(OSCCW.JK,DCCCW)
C DCCCW=.5
NOTE
NOTE INDEPENDENT HARVESTER SECTOR
1L UOIH.K=UOIH.J+(DT)(RRIH.JK-PSIH.JK)
12N UOIH=(RRIH)(DT)
1L UODIH.K=UODIH.J+(DT)(RRDIH.JK-PSDIH.JK)
12N UODIH=(RRDIH)(DT)
1L UOCIH.K=UOCIH.J+(DT)(RRCIH.JK-PSCIH.JK)
12N UOCIH=(RRCIH)(DT)
8A UOIH.K=UOIH.K+UODIH.K+UOCIH.K
8A RRIH.K=RRIH.JK+RRDIH.JK+RRCIH.JK
12A UNIH.K=(RRIH.K)(DT)
52L IAIH.K=IAIH.J+(DT)(CRIH.JK-PSCIH.JK-PSDIH.JK-PSIH.JK) INV ACT IH
6N IAIH=MIIH MIDIH+MICIH
20A STCIH.K=UOCIH.K/DT
20A STDIH.K=UODIH.K/DT
17A AA.K=(IWP)(1)(1)+(DWP)(IHDP)(1)+(CWP)(IHCP)(1)
20A STIIH.K=UOIH.K/DT
46A NIIH.K=(RRIH.JK)(IAIH.K)(1)/((RRIH.K)(DT)(1))
46A NDIH.K=(RRDIH.JK)(IAIH.K)(1)/((RRIH.K)(DT)(1))
46A NCIH.K=(RRCIH.JK)(IAIH.K)(1)/((RRIH.K)(DT)(1))
51R PSIH.KL=CLIP(STIIH.K,NIIH.K,NIIH.K,STIIH.K)
51R PSDIH.KL=CLIP(STDIH.K,NDIH.K,NDIH.K,STDIH.K)
51R PSCIH.KL=CLIP(STCIH.K,NCIH.K,NCIH.K,STCIH.K)
6A IDIIH.K=MIIH.K
12A MIIH.K=(RRIH.K)(.20)

```



```

6A  IDCH,K=MICH,K
12A  MICH,K=(RRCCH,K)*(0.20)
25A  PNCCH,K=RRCCH,JK+(1/DT)*(UOECCH,K+IDCH,K-IACH,K-UNCH,K+0+0)
12A  CCCH,K=(PCH,K)*(PPCH)
C    PPCH=100
54A  PCH,K=MIN(PCH1,K,PCH2)
12A  PCH1,K=PCH1,J+(DT)*(ARCH,JK+0)
24N  PCH1=(1/PPCH)*(RRCCH+0+0+0+0)
46A  PCH2,K=(A)*(3100)*(CC,K)/((PPCH)*(1)*(1))
12A  CC,K=(CWP)*(CHCP)
7A   DIFF3,K=PNCCH,K-CCCH,K
54R  ARCH,KL=MIN(ARCH1,JK,1)
42R  ARCH1,KL=DIFF3,K/((PPCH)*(DACH))
C    DACH=4
51R  CRCH,KL=CLIP(CCCH,K,PNCCH,K,PNCCH,K,CCCH,K) CUT RATE ACT AT CH
PRINT 1)ARDH,ARCH,CPIM,CPIW,DIFF1,DIFF2,DIFF3,CPDCW,CPCW/2)STM,STIW,STD
X1   W,STCW,STCIH,SIC,ARIH/3)IAM,IAIW,IADW,IACW,IAIH,IADH,IACH/4)IDM,IB
X2   IW,IDDW,IDCW,IDIH,IDDH,IDCH/5)PTIM,PTDM,PTCM,PTIW,PTDDW,PTDCW,PTIC
X3   W,PTDCW,PTCCW/6)ODM,ODIW,ODDW,ODCW/7)CRIH,CRDH,CRCH/8)ORM,RIIW,RRD
X4   W,RRCW,RIIH,RRDIH,RRCIH,RRDDH,RRCDH,RRCCH/9)SSM,PSIW,PSDW,PSCW,PS
X5   IIH,PSDIH,PSCIH,PSDDH,PSCDH,PSCCH/10)UOM,UOIW,UODW,UOCW,UOIH,UODI
X6   H,UOCH,UODH,UOCDH,UOCCH/11)PIH,PDH,PCH
PLOT IAM=M,IDM=Z/IAIW=I,IADW=D,IACW=C/PIH=R/PDH=S,PCH=T
SPEE DT=.1/LENGTH=104/PRTPER=13/PLTPER=2

```

BIBLIOGRAPHY

1. Chidester, G. H., "The Future of Pulp and Paper," Forest Products Journal, May, 1964, pp. 232-234.
2. Beggs, A. K., "The Industry Looks Ahead," 1965 Pulpwood Annual, May 10, 1965, pp. 47-49.
3. Woodpulp Mills in the United States by State and Type of Product, U. S. Department of Agriculture, Forest Service, Washington, June, 1961, p. 18.
4. A Statistical Report on the Pulp and Paper Industry in the South, Southern Pulpwood Conservation Association, Atlanta, Georgia, 1967, p. 1.
5. Hodges, G., "The Southern Stride," Pulp and Paper, Vol.39, February 15, 1965, pp. 52-53.
6. Valente, George A., "A Simulation of the Pulpwood Procurement System," A Research Proposal, Georgia Institute of Technology, School of Industrial Engineering, March 6, 1968.
7. Britt, Kenneth W., Handbook of Pulp and Paper Technology, Reinhold Publishing Corporation, New York, 1964.
8. Jeffords, A. K., Jr., "Trends in the Pine Pulpwood Marketing in the South," Journal of Forestry, Vol. 54, 1956, p. 464.
9. Lee, R. E. III, "Directing Mechanization to Producers," Pulp and Paper, Vol.39, May 10, 1965, pp. 55-56.
10. "A Dynamic, Mathematical Mode of Pulpwood Production in the Southeast," Battelle Memorial Institute, January 15, 1963.
11. Hamilton, Henry R., "Attacking the Paper Industry Problem by Simulation," TAPPI, Vol. 47, November, 1964, pp. 678-683.
12. Plafcan, Dan J., "Pulpwood Harvesting, Supervisor or Crewleader, What Manner of Man Is This?," Georgia Institute of Technology, School of Industrial Engineering, June 5, 1968.
13. "Pulpwood Stands, Procurement and Utilization," TAPPI Monograph Series No. 4, The Technical Association of Pulp and Paper Industry, 1947, pp. 114.

14. Albin, J. R., "Kimberly-Clark's Wood Procurement Program in Central Alabama," Technical Paper of the American Pulpwood Association, April, 1967, p. 18.
15. Evans, John C. W., "Domtar's New Market Pulp Mill Has Many Interesting Features," Paper Trade Journal, June 12, 1967, pp. 62-70.
16. Silversides, C. R., "The Influence of Mechanization on Harvesting and Transportation Methods," Pulp and Paper Magazine of Canada, Vol. 67, No. 10, October, 1966, pp. W R 473-481.
17. Dyer, Harry, "Woodhandling--The Last Frontier In the Battle to Cut Operating Costs," Paper Trade Journal, September 13, 1965, pp. 63-65.
18. Naylor, T. H., Balintfy, J. L., Burdick, D. S., and Chu, K., Computer Simulation Techniques, John Wiley & Sons, Inc., New York, 1966, p. 3.
19. Forrester, Jay W., Industrial Dynamics, The M.I. T. Press, Cambridge, Massachusetts, 1961
20. Jarmain, W. Edwin, Problems in Industrial Dynamics, The M.I. T. Press, Cambridge, Massachusetts, 1963.
21. Packer, D. W., Resource Acquisition in Corporate Growth, The M.I. T. Press, Cambridge, Massachusetts, 1964.
22. Clark, Thomas B., "The System Dynamics of Product Development Control," Master's Thesis, Georgia Institute of Technology, School of Industrial Engineering, May 1968, p. 18.
23. Pugh, Alexander L., III, Dynamo User's Manual, The M.I. T. Press, Cambridge, Massachusetts, 1963.