

This PDF was created from the British Library's microfilm copy of the original thesis. As such the images are greyscale and no colour was captured.

Due to the scanning process, an area greater than the page area is recorded and extraneous details can be captured.

This is the best available copy

50265'84

attention is drawn to the fact that the
right of this thesis rests with its author.
This copy of the thesis has been supplied
on condition that anyone who consults it is
expected to recognise that its copyright rests
with the author and that no quotation from
it is to be published without the author's prior
consent.

326

D50266/84

GOODWIN E.M.

326

A STATISTICAL STUDY OF SHIP DOMAINS

by

Elisabeth M. Goodwin M.Sc.

A thesis submitted to the Council for National Academic
Awards for the Degree of Doctor of Philosophy.

The research programme was carried out at the City of
London Polytechnic.

CALCUTTA HOUSE

January 1975

Acknowledgements

My thanks are due to the following people for their help in the preparation of this thesis.

Mr. P.R. Goddard of the City of London Polytechnic for acting as Director of Studies.

Dr. J.F. Kemp of the City of London Polytechnic for suggesting the problem and for acting as supervisor.

Dr. C.M. Phillips of the London School of Economics and Political Science for guidance in the writing of the thesis.

Captain R. Phinn formerly of the City of London Polytechnic and the crew of the M.V. 'Sir John Cass' for help in the marine traffic surveys.

Captain R. Sanders of the Harwich Pilot Station for help in the collection of data.

Captain C. Turquand and the staff of the radar section at the City of London Polytechnic's School of Navigation for help in the collection of data from the marine radar simulator.

The Maritime Science division of the National Physical Laboratory for the use of films collected during their Dover Strait survey.

Abstract

The thesis is an attempt to establish the water area required by any one ship for safe and efficient navigation. The concept of a ship domain has been considered, which may be defined as the effective area around a ship which a navigator would like to keep free with respect to other ships and stationary objects. This area will not be the same for all ships but will depend on a variety of factors such as speed, size of ship and density of traffic among others.

The first part of the project was concerned with the collection of data from two separate sources: one being the performance of ships' officers in collision avoidance exercises on a marine radar simulator and the second being marine traffic surveys conducted in the Sunk area of the North Sea. The collection of data on ship movements and their processing for analysis by computer comprised the early work of the thesis. The next section of work was concerned with the development of a technique for evaluating the size of the domain and in particular the range of the domain boundary from the ship referred to as the domange. Very little work appears to have been done on this topic previously so several possibilities were considered before a decision was made as to the most suitable technique.

Once this had been established results were obtained for a variety of conditions such as different sea area, length of ship and experience of the navigator as well as those previously mentioned and others.

The final part of the thesis considers possible applications of the results in a variety of situations which are of current and future interest in marine traffic studies.

Contents

| | | <u>Page</u> |
|-------------|---|-------------|
| Chapter 1 | INTRODUCTION The general problem: progress in marine traffic engineering: the particular problem. | 6 |
| Chapter 2 | DESCRIPTION OF A SHIP DOMAIN Other domains: ship domain geometry: controlling factors: other work on ship domains: applications of the study. | 16 |
| Chapter 3 | THE COLLECTION OF DATA Sources of data: marine radar simulator: marine traffic surveys: other sources. | 25 |
| Chapter 4 | THE PROCESSING OF THE DATA The required form for the secondary data: simulator data records: Sunk survey data records: comparison of methods: critical analysis of the data. | 57 |
| Chapter 5 | EVALUATION OF THE DOMAIN BOUNDARY The main hypothesis: possible definitions of the domange: possible methods of calculating the domange: hypothesis tests for the presence of a domain: standard errors of the domanges. | 84 |
| Chapter 6 | INDEPENDENT VARIABLES AFFECTING THE SIZE AND SHAPE OF A SHIP DOMAIN General method: sea area: relative velocity: size of ship: maximum speed of ship: experience of navigator: fishing vessels: buoys: channels: traffic density: sectors. | 131 |
| Chapter 7 | AN EVALUATION OF THE PROJECT ON SHIP DOMAINS Applications of the study: external overall control of sea traffic: encounter rates: traffic flows: computer simulation models: appraisal of the project. | 169 |
| Appendix I | Additional tables accompanying Chapter 1. | 192 |
| Appendix II | II.I Extract from the Highway Code II.II Extracts from the International Regulations for preventing collisions at sea. | 194 |

| | | <u>Page</u> | |
|--------------|----------|--|-----|
| Appendix III | III.I | Marine radar simulator specification | 199 |
| | III.II | Initial situations for the simulator exercises | |
| | III.III | Sample sizes by type of exercise: simulator data | |
| | III.IV | Navigational charts of the Sunk survey area | |
| | III.V | Details on the Marconi Radio-Locator 16 | |
| | III.VI | Equipment | |
| | III.VII | Difficulties in using radar photographs | |
| | III.VIII | Reasons for the loss of photographs in the three Sunk surveys | |
| | III.IX | Comparison between the distribution of ships by size identified in the Sunk surveys and worldwide | |
| Appendix IV | IV.I | Commentary on an exercise | 240 |
| | IV.II | Format of the computer records: simulator data | |
| | IV.III | Special data codes: simulator data | |
| | IV.IV | Checking procedures: simulator data | |
| | IV.V | Format of the computer records: Sunk data | |
| | IV.VI | Checking procedures: Sunk data | |
| | IV.VII | A statistical investigation into the distribution of number of ships per sector: simulator data | |
| | IV.VIII | Typical echo strength curves for various targets | |
| | IV.IX | Comparison of the distributions obtained from the three separate Sunk surveys. | |
| Appendix V | V.I | Additional tables accompanying Chapter 5 | 260 |
| | V.II | Additional graphs accompanying Chapter 5 | |
| | V.III | Summary of the method of displaced numbers | |
| | V.IV | Examples of the full calculations using the method of displaced numbers | |
| | V.V | Example of the calculations using the slope method | |
| | V.VI | Calculations for the standard errors of the domanges | |
| Appendix VI | VI.I | The Kruskal-Wallis one-way analysis of variance | 288 |
| | VI.II | Additional graphs accompanying Chapter 6 | |
| | VI.III | Comparison of the distributions obtained from the simulator exercises: Dover Strait and the Sunk surveys | |
| | VI.IV | Comparison of the mean relative speeds in the simulator exercises: Dover Strait and the Sunk surveys | |
| | VI.V | Comparison of the distribution of ships by size in the Dover Strait: simulator exercises and a survey of ships in the Dover Strait | |
| | VI.VI | Distribution of ship size by area in the simulator data | |
| | VI.VII | Joint distribution of ship size by gross tonnage and maximum speed: simulator data | |
| | VI.VIII | Distribution of length of sea-experience of the navigator by area: simulator data | |
| | VI.IX | Distributions with respect to fishing boats | |
| | VI.X | Distributions with respect to buoys under different circumstances | |

| | <u>Page</u> |
|--|-------------|
| Appendix VII The Poisson distribution as an approximation to the distribution of ships in the Dover Strait. | 306 |
| Appendix VIII Computer programs | 307 |
| List of Symbols | 318 |
| Notes on Tables and Figures | 320 |
| References | 322 |

| | <u>Page</u> |
|--|-------------|
| Appendix VII The Poisson distribution as an approximation to the distribution of ships in the Dover Strait. | 306 |
| Appendix VIII Computer programs | 307 |
| List of Symbols | 318 |
| Notes on Tables and Figures | 320 |
| References | 322 |

CHAPTER 1

Introduction

THE GENERAL PROBLEM

In recent years there has been an increasing interest in the sea, for it is to the world a means of communication, a source of food and a source of minerals. As the land becomes more crowded and its resources become scarcer, so more attention is paid to the sea. This all contributes to the increased problems involved in sea transport.

It has been predicted, (Thompson (1972))⁽¹⁾ that by 1980 the total number of ships will have increased by about 40% on the level for 1969. Table 1.1 shows a comparison by type of ship between the total ship populations of 1969 and 1980 (estimated); it is interesting to note that general cargo ships and passenger liners, the largest group of ships in 1969, are expected to decrease in numbers but the other types of ship will all increase

| Vessel Type | Total Ship Population | | 1980 Figures as a Percentage of the 1969 Figures |
|-----------------------------|-----------------------|-------|--|
| | 1969 | 1980 | |
| Tankers | 5869 | 7980 | 136 |
| Ore and Bulk Carriers | 2378 | 4115 | 173 |
| General Cargo and Passenger | 26100 | 16467 | 63 |
| Fishing | 11949 | 17900 | 150 |
| Others | 3980 | 23554 | 592 |
| Total | 50276 | 70016 | 139 |

Notes (see p.320)

TABLE 1.1 Comparison of Estimated Ship Populations 1969 and 1980

The changing pattern is again illustrated in Table 1.2 which gives a comparison between 1969 and 1980 of the estimated number of ships per day passing through certain key regions of sea. Although it is

| Region | Ships per Day | |
|-----------------------|---------------|------|
| | 1969 | 1980 |
| English Channel | 400 | 340 |
| Strait of Gibraltar | 215 | 180 |
| Cape of Good Hope | 160 | 225 |
| Coast of Japan | 100 | 190 |
| Malacca Strait | 85 | 180 |
| Masqat (Persian Gulf) | 80 | 180 |

Notes (see p.320)

TABLE 1.2 Comparison of the Estimated Daily Traffic Flow in Certain Sea Areas, 1969 and 1980

expected that the most heavily congested regions in 1969, viz the English Channel and the Strait of Gibraltar, will have a decrease in traffic, they will still be very busy and in other areas the congestion will increase. It should be noted that the forecasts for 1980 do not take into account changing political situations such as the possible reopening of the Suez Canal. A further comparison is given in Table I.1 Appendix I.

Coupled with the increase in the volume of marine traffic expected, is the current trend towards building larger and faster ships to transport huge quantities at any one time.

A comparison of the growth of the number of ships and their increase in size over the 10 year period 1963-1973 is given in Table 1.3. The increase in number of ships in this period is just over 50%. By reference to the figures for oil tankers, it can be seen that they are the majority of the very large ships. A larger table showing more details of the distribution by size for each type of ship and for each of the two years is given in Appendix I page 193. In 1963 the largest ships were just over 40,000 gross tons but by 1973 the largest ships were over 140,000 gross tons.

| Type of Ship | Gross Tonnage | 100 - | 2000 - | 10000 - | 40000 | Total |
|--------------|---------------|-------|--------|---------|----------|-------|
| | | 1999 | 9999 | 39999 | and over | |
| Oil Tankers | 1963 | 1909 | 656 | 2381 | 38 | 4984 |
| | 1973 | 2205 | 1288 | 2340 | 774 | 6607 |
| Others | 1963 | 21527 | 11578 | 1471 | 11 | 34587 |
| | 1973 | 37144 | 11288 | 4145 | 422 | 52999 |
| TOTAL | 1963 | 23436 | 12234 | 3852 | 49 | 39571 |
| | 1973 | 39349 | 12576 | 6485 | 1196 | 59606 |

Notes (see p.320)

TABLE 1.3 Comparison of the Distributions of the World's Ships by Size and by Type in 1963 and 1973

These larger ships need deeper water than smaller ones so that particularly in relatively shallow water such as the North Sea, there is less navigable space for them. Additionally, because of their increased size their manoeuvrability is often restricted. This is illustrated in Table 1.4 which gives for four varieties of tanker, details of their performance when a crash stop is necessary. It shows the time and distance taken to reduce from an initial service speed to a speed of 0 knots.

The likely consequences if no action is taken in the light of the trends described above are not difficult to imagine. At present the number of serious accidents at sea per annum is small, but the rate for casualties of a minor nature is high. Figures for 1973⁽²⁾ show that there was nearly a 20% chance that a ship of 500 gross tons and over would suffer minor damage in some way during a year.

Table 1.5 gives details of the number of ships of 500 gross tons and over reported as total losses or partial losses during 1973. It should be mentioned that the figures for total losses include constructive total losses which when considered over a period of time can be seen to be increasing. This is, however, most probably only a reflection on the increase in repair costs, making it more frequently cheaper to buy a new

| Tonnage d.w.t. | Propulsion Type | Length BP. (ft.) | Draught ft. | Initial Speed (knots) | Time to Stop (mins) | Distance to Stop (n. miles) |
|-------------------|--------------------|---------------------|----------------|-----------------------------|---------------------------|-----------------------------------|
| 18000 | Steam | 530 | 31 | 15 | 9.5 | 1.05 |
| 50000 | Steam | 715 | 40 | 16 | 11.4 | 1.49 |
| 110000 | Motor | 830 | 49 | 14 | 13.2 | 1.58 |
| 210000 | Steam | 1017 | 62 | 16 | 22.1 | 2.60 |

Notes (see p.320)

TABLE 1.4 The Time and Distance Taken by Various Types of Tanker to do a Crash Stop

| Nature of Casualty | Number of Ships of 500 Gross Tons and Upwards | | | Number of Ships as a Percentage of the Total Number of Ships of 500 Gross Tons and Upwards 31036 = 100% | | |
|---|--|-------------------|-------|--|-------------------|-------|
| | Total Losses | Partial Losses | Total | Total Losses | Partial Losses | Total |
| Weather Damage | 35 | 500 | 535 | 0.1 | 1.6 | 1.7 |
| Foundering and Abandonment | 15 | - | 15 | 0.0 | - | 0.0 |
| Strandings | 36 | 727 | 763 | 0.1 | 2.4 | 2.5 |
| Collisions | 20 | 1185 | 1205 | 0.1 | 3.8 | 3.9 |
| Contact Damage | 5 | 749 | 754 | 0.0 | 2.4 | 2.4 |
| Fires and Explosions | 50 | 416 | 466 | 0.2 | 1.3 | 1.5 |
| Missing | 3 | - | 3 | 0.0 | - | 0.0 |
| Damage to machinery, shafts and propellers | 3 | 1724 | 1727 | 0.0 | 5.6 | 5.6 |
| Other casualties | 12 | 587 | 599 | 0.0 | 1.9 | 1.9 |
| Total | 179 | 5888 | 6067 | 0.5 | 19.0 | 19.5 |

Notes (see p. 320)

TABLE 1.5 Annual Summary of Casualty Returns 1973

ship than to salvage and repair the old one. The second half of the table gives the number of casualties in 1973 as a percentage of the total number of ships at 1st July 1973. It is possible that any one ship may be a casualty more than once during a year, so this gives a measure of the accident rate per ship afloat. Even if the accidents involving damage to machinery, shafts and propellers are omitted, there is still about a 14% chance that a ship will suffer minor damage in some way during a year.

The resultant loss of life is usually low even in the more serious collisions due to the increased safety awareness in the construction of ships. An example of this is given by the Andrea Doria-Stockholm collision in 1956 when only 40 lives were lost out of a total of 2240 passengers and crew on the two ships combined; but the Andrea Doria sank. However, many of the minor casualties result in environmental damage, which is a problem of growing concern and importance. It took an incident as spectacular as the 'Torrey Canyon' stranding in 1967 to make people aware of the dangers of such a situation, (for instance Oudet (1968)⁽³⁾).

With the large quantities of oil and chemicals being carried in single units it is essential that the present rate of casualties should be reduced if cumulative and ultimately disastrous pollution of the sea is to be prevented.

Even if the safety angle of the problem were to be set aside, the increasing congestion in marine traffic implies increasing costs. Vanags (1972)⁽⁴⁾ considers some of the aspects of this.

Thus it is realized now that the general requirement is to look for a more efficient use of available water areas. This has led to the development of a completely new field of study known as marine traffic engineering. It is interesting to realize that the sea which is one of the oldest means of transport known to man has in fact remained one of the freest and most individualistic long after it was found necessary to study the air and the road more closely.

PROGRESS IN MARINE TRAFFIC ENGINEERING

Marine traffic engineering has been defined 'as the study of marine traffic and the application of the results of such a study to improvements in navigation facilities and traffic regulation, with the aim of making sea transport both safe and efficient', (Silverleaf (1972)⁽⁵⁾).

As marine traffic systems are just another form of transport, the different aspects of the subject are broadly the same as for any transport study. The main headings under which the systems can be studied are thus:-

Traffic Flow and Patterns
Accident Statistics and Collision Avoidance
Route Characteristics
Separation and Routing Systems
Information and Control Equipment
Economic Aspects
Operational Procedures.

In the previous section, the general scene was set. It is perhaps worthwhile at this point, however, to consider a little of the historical background of the subject, leading to the point in time when marine traffic engineering has become recognized as an important science.

To the navigator, the topic which has always been of importance is that of collision avoidance and rules concerning it have been in existence for a long time; the earliest of which record has been found are the Rhodian Laws dating from the third or second century BC or earlier. An interesting historical development is given in Kemp (1974)⁽⁶⁾. However, the main emphasis was on safety with much less thought given to efficiency.

One of the first studies which combined safety and efficiency was the development of the war-time convoys in 1941. Mathematical relationships were developed between the striking rate per convoy (the ratio of the number of ships sunk to the number of ships that sailed) and the independent variables of number of escorts, size of convoy, speed of convoy and amount of air cover. The new feature of the study was again not the use of convoys, as they were first introduced by the Spanish with their treasure ships from South America, but how they could be used efficiently. It is also interesting to note that this study was one of the first whereby operational research was developed as a science.⁽¹²⁾

After the war came the setting up of the British Institute of Navigation in 1947 which among its objectives included 'To advance the science and practice of navigation and its associated sciences'. Some of the early papers published in its journal considered the ideas suggested by marine traffic engineering such as the one by Parker and Le Page (1949)⁽⁷⁾.

Operational research techniques were applied to certain specific aspects of marine transport in the next few years. For instance, the example of ships queuing for berths is included in many textbooks on queuing theory (e.g. Sasieni, Yaspan, and Friedman (1959)⁽⁸⁾, one of the classic texts!).

However, reference to Beattie (1968)⁽⁹⁾ gives some idea of what little systematic study of marine traffic has been undertaken up to that time. On 1st June 1967 a voluntary routing system was introduced in the Dover Strait and yet in the 45 months following, there were 40 collisions compared to 36 collisions in the 45 months immediately preceding the introduction of the scheme⁽¹⁰⁾. The necessity to evaluate the existing scheme and alternatives, together with the 'Torrey Canyon' stranding in 1967 helped to move opinion over to the need for more knowledge of what was happening at sea. During 1971, five short period surveys of shipping in the Dover Strait were made⁽¹¹⁾ and a continuous survey was started in 1972⁽¹³⁾.

In other countries various amounts of relevant work have been done but by far the most has come from Japan. The first extensive traffic survey was carried out in 1963 and a brief overview of the results stemming from this and subsequent surveys is given in Toyoda and Fujii (1971)⁽¹⁴⁾. The Japanese are traditionally a maritime nation with highly congested waters, and they are undoubtedly the pioneers in this subject.

In 1972, the first international conference on marine traffic engineering in this country was held at the National Physical Laboratory at Teddington. The large audience was sufficient alone to give proof of the real interest in the subject. The report of the proceedings⁽¹⁵⁾, however, gives concrete evidence of the progress that has been made in many aspects and also of the many interesting and exciting problems that have yet to be tackled.

THE PARTICULAR PROBLEM

The particular aspect with which this research is concerned is to try and establish the water area required by any one ship for safe navigation. This has led to the consideration of the idea of a ship domain which may be defined as the effective area around a ship which a navigator would like to keep free with respect to other ships and stationary objects. To illustrate this idea Fig. 1.1 overleaf gives for one particular ship during a crossing of the English Channel from Dover to Dunkerque, the relative tracks of some other ships and buoys. Around the ship there is the area of clear water free of all other tracks and this constitutes the domain of the ship. The actual size and shape of the domain it is considered, will be dependent upon various factors. Typical ones will be the size and type of ship, both of the navigator's own and of those he encounters, the experience of the navigator, the speed of the ship, the weather conditions prevailing, and the type of waters through which the ship is passing.

The concept of the ship domain is developed in more detail in the next chapter.

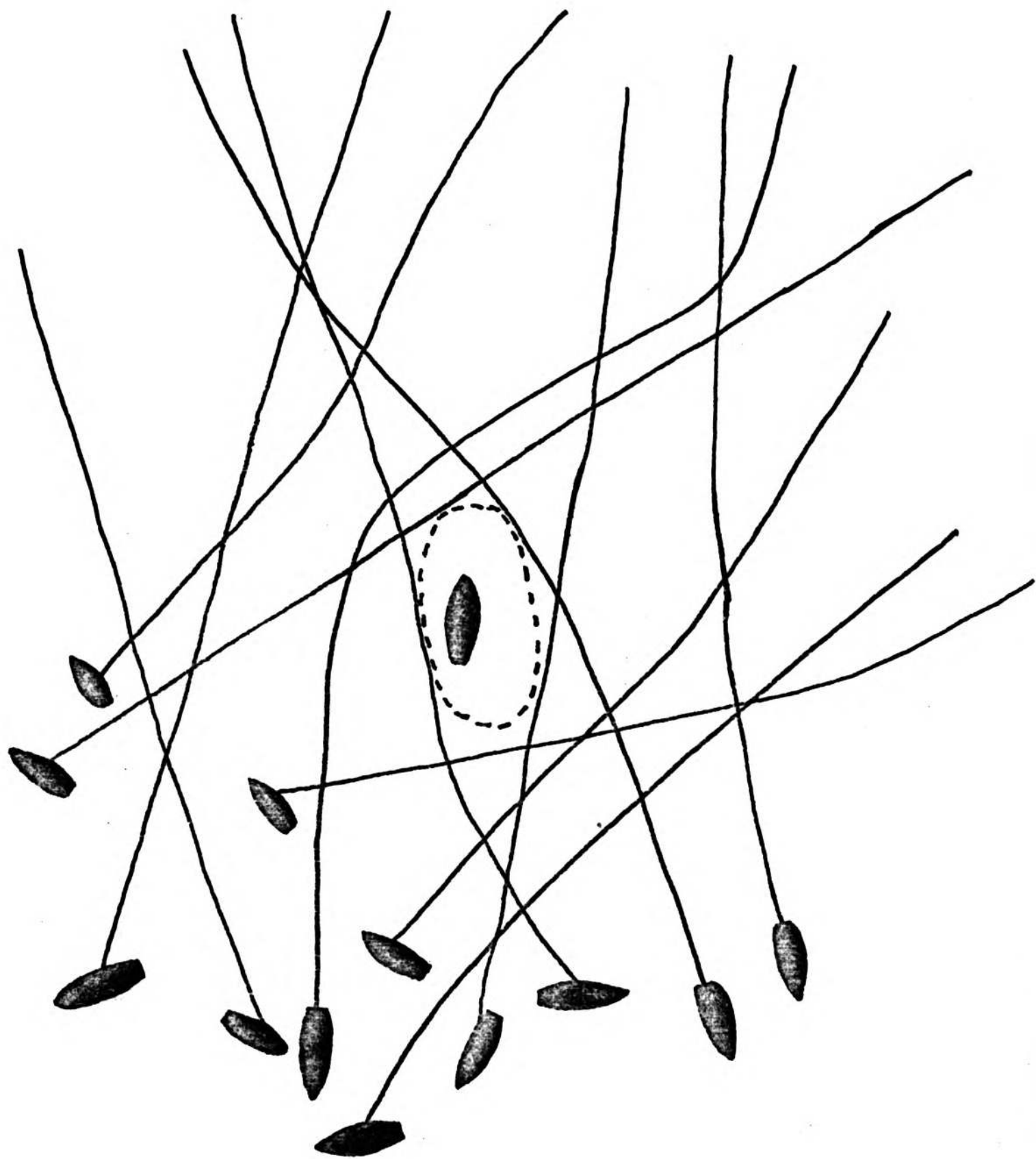

- - - - - Domain boundary

FIG. 1.1 Domain Boundary of a Ship Suggested by the Relative Tracks of Other Ships

CHAPTER 2

Description of a Ship Domain

OTHER DOMAINS

When a ship passes through an area such as the Dover Strait, it is hypothesised that the navigator manoeuvres so that other ships should not enter a certain area surrounding his own ship. Such an area is termed a 'ship domain'. Similar concepts exist with other modes of transport and indeed in any person to person situation.

1. Personal Domains

Whenever one person is talking to another whether standing or sitting, there is a certain distance apart at which he feels most relaxed and comfortable. Not only one's companion, but the circumstances under which the discussion takes place, both in terms of physical surroundings and topic of conversation will be factors affecting this distance. Once the distance apart becomes too close for comfort in the circumstances, the personal domain has been violated and action may be necessary. Two people who have worked on this idea are Little (1965)⁽¹⁶⁾ and Hall (1955)⁽¹⁷⁾. Among various findings are some on how nationality affects the personal domain. Americans will not stand nearer than 18-20 inches when talking to a stranger of the same sex. If forced to stand closer than this they turn and face at right angles or side by side. At international gatherings with Latin American or Middle Eastern people, Americans have been observed to retreat backwards or gyrate in circles in an effort to preserve their preferred separation.

2. Road Domains

With road transport attempts are made to suggest what the domain limits should be in terms of the distance left between one's own car and the car in front. The Highway Code⁽¹⁸⁾ contains a table of shortest stopping distances for various car speeds and a recommendation to drivers to never get closer to the vehicle in front than the required stopping distance. Full details of this are given in Appendix II.

Anyone who has driven a car, however, will know that in practice these standards are not kept to by every vehicle but are very much dependent on the temperament and experience of the driver.

3. Air Domains

When one considers the air situation immediately there are three dimensions of movement to be considered. The other major difference is that control is actually exercised over the movements of aircraft, so that they keep to predetermined routes. Thus the concept of a domain which navigators would themselves like to keep clear, and which changes under different conditions no longer applies in the same sense. Instead there are separation standards which are exercised by the air traffic controllers and as the title suggests are standard from aircraft to aircraft. These standards are set so as to minimise the collision risk arising from flying errors which, in practice, may result in actual positions of the aircraft very different from their planned and hence intended positions at any time. Examples of this approach are given in Reich (1964)⁽¹⁹⁾ and ⁽²⁰⁾.

The three types of domain described above obviously differ in nature. With a personal domain, the actual safety concept is expressed only as a feeling of comfort which is obviously individually determined by personality and situation. With an aircraft domain the safety element becomes the most overriding factor, so that individual personality differences are neglected and the domain is a rigidly defined concept. The road domain is probably therefore the most similar concept to a ship domain, since both safety factors and personality factors must play a part in the spacing of cars on a road. However, since it is a two-dimensional problem, the ship domain is a much more complex question than that of the one-dimensional road domain.

SHIP DOMAIN GEOMETRY

The easiest representation of a ship domain would be a circle centred on the ship. This could be defined simply in terms of the radius of the circle. Allowing for the ship's dimensions whereby the ship is longer than it is wider, a slightly more realistic representation of the domain would be an ellipse centred on the ship with principal axis in the direction of the ship's head. However, consideration of the International Rules for preventing collisions at sea (1960)⁽²¹⁾ would suggest that both of these two oversimplify the situation. (The appropriate sections of the Rules are given in Appendix II). Rule 18 which is for ships in an end-on or nearly end-on situation says that each must alter course to starboard so that they pass on the port side of each other, if there is danger of collision. If two ships are

crossing and there is a collision risk then Rule 19 states that the vessel which has the other on her starboard side must keep out of the way of the other. The effect of these two rules, it is thought, will be that navigators are prepared to tolerate other ships closer in a sector on the port side than in a sector on the starboard side.

The rules define an overtaking vessel as one coming up with another one from any direction more than $22\frac{1}{2}$ degrees (2 points) abaft her beam (Rule 24). It is the responsibility of the overtaking ship to keep out of the way of the ship it is overtaking. Thus any one ship does not have to worry so much about ships in a sector astern, between $112\frac{1}{2}^{\circ}$ and $247\frac{1}{2}^{\circ}$ of its own heading. As a result it is expected that navigators are willing to tolerate other ships closer in this sector than ahead of their own ship. However, the relationship between the port bow sector and the astern sector is not certain, either might have the boundary further away. Fig. 2.1 shows a typical domain that is expected. If the collision regulations were the only factor then the solid line shows the resulting domain boundary with sharp discontinuities at the ends of the sectors. However in practice, observations will not be very precise, so the dotted line gives a more realistic picture.

CONTROLLING FACTORS

The size of the domain and possibly sometimes the shape, will depend upon a number of factors. The aim of this thesis is not only to establish mean values for the dimensions of the domain but also to investigate some of these controlling factors. In the comparisons with the domains in other situations it was seen that there are three types of factors:

- (a) Psychological factors
- (b) Physical factors: specific to one ship
- (c) Physical factors: general to all ships in an area.

A PSYCHOLOGICAL FACTORS

1. Length of Sea-Experience of Navigator

It is thought that probably there will be an inverse relationship between the size of the domain and the length of sea-experience of the navigator. Some evidence to suggest this has been given by Kemp (1974)⁽⁶⁾ in his experiments into factors affecting collisions at sea. One of his findings was that given a certain type of encounter subjects with greater experience tended to resolve the situation more quickly but with

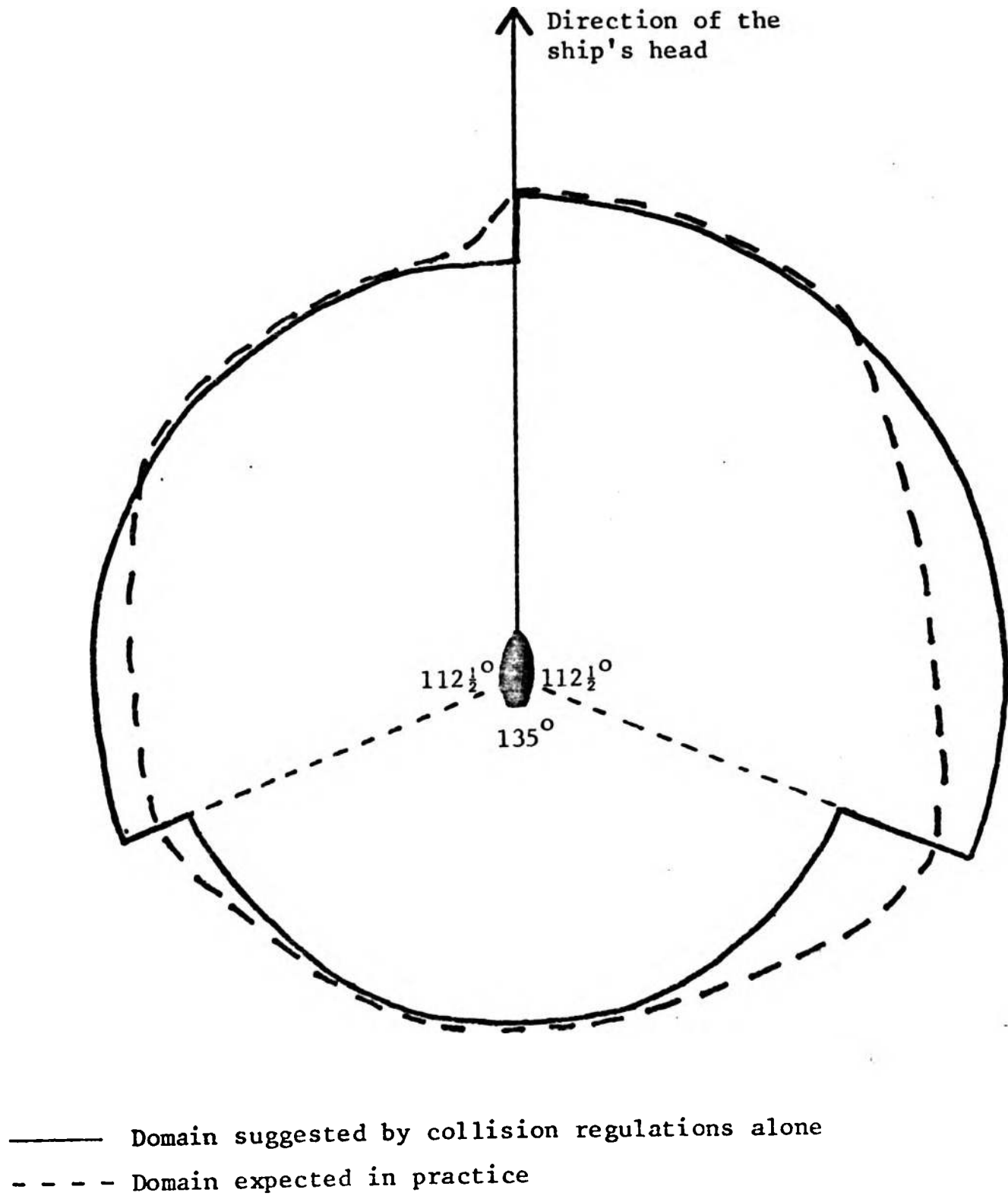

Fig. 2.1 Hypothetical Shape of a Typical Ship Domain

manoeuvres entailing a greater measure of risk than did subjects with less experience. Thus it is expected that a man who has been at sea for a number of years will probably be willing to accept a smaller sea-area to navigate in than a less experienced man.

2. Length of Sea-Experience of the Navigator in a Specific Area

It is expected that not only the actual sea-experience of the navigator in any part of the world will affect the size of the domain but also his experience in the specific area where he is at any time. In particular if a ship is being piloted through an area, the pilot may be prepared to accept a smaller domain than would one of the ship's officers.

3. Personality of the Navigator

If one thinks of the situation when driving a car, the driver who insists on sitting on one's bumper is usually considered to be an aggressive extrovert - at least by oneself! Hence it is to be expected that there might be a relationship between the size of the ship domain and the personality of the navigator. In the work by Kemp (1974)⁽⁶⁾ a significant statistical relationship was found whereby highly extroverted navigators used more exaggerated manoeuvres than those with a less high extroversion score, some resulting in large miss distances in an encounter, others in very small miss distances. However there was no significant relationship between a person's score in a neurotic/stable test and the number of manoeuvres taken to resolve an encounter. These results make it difficult to predict what form the relationship between personality and size of domain would take. Unfortunately it was not possible to study this aspect of the problem in this thesis but is one of the extensions of the project that could be considered.

B. PHYSICAL FACTORS: SPECIFIC TO ONE SHIP

1. Size of Navigator's Own Ship

The size of his own ship is expected to affect the size of the domain which the navigator wants. The larger the ship, the larger the domain he will want probably, as his manoeuverability will be less than in a smaller ship. It is therefore hypothesised that there will be a positive correlation between the size of the domain and the size of the ship.

2. Type of Navigator's Own Ship

The manoeuvrability of a ship is also changed according to its type. For instance a passenger liner is capable of much faster speeds than a general cargo ship of the same tonnage. The effect on the domain will probably reflect some sort of interaction between the type and size of the ship but both variables should be considered.

3. Size and Type of Other Ships

If a navigator were always aware of the exact nature of the other ships around him, this variable might well be of importance. However, if the visibility is poor and the navigation is being done by radar it is impossible to get much information about the other ships in the area regarding their size and type. Even at night the lights on a ship may make its size deceptive. Hence in general, this variable is not worth considering directly but will be considered indirectly if weather conditions are taken into account (see below). The main exception is if the other ship is a fishing boat, which is usually easy to identify on a radar screen as its path while fishing may be very erratic. Rule 26 of the International Collision regulations gives responsibility to other vessels to keep out of the way of fishing vessels. This rule together with the erratic behaviour of fishing boats is likely to alter the shape of the domain and its size.

4. Speed

As both the speed of the navigator's own ship and that of the other ship which is being considered when a navigational decision is made, are going to affect this decision, another relevant variable is the relative velocity of the two ships. A positive correlation is expected between the domain dimensions and the relative velocity with which other ships are travelling. Another positive correlation is expected between the domain dimensions and the actual speed at which a ship is travelling. This second relationship is however likely to involve some interaction with the variables measuring the size and type of the ship.

C PHYSICAL FACTORS: GENERAL TO ALL SHIPS IN THE AREA

1. Weather Conditions

Different weather conditions are expected to affect the size of the domain. In particular the visibility is expected to make the biggest difference. A recent report⁽²²⁾ into the circumstances of collisions in the Dover Strait area showed that at least 82% of all collisions in the period 1st June 1959 to 31st May 1971 in that area occurred in poor visibility, defined as less than 4 kilometres. It is therefore expected that there will be an indirect relationship between domain size and visibility, as the domain will get larger as the visibility gets smaller. The International Collision regulations (Rule 16) (1960) require a ship to go at moderate speed in poor visibility, so the variables of speed and visibility can be expected not to be independent of each other. Unfortunately this is another variable which it has not been possible to study in detail for this thesis but provides another possible extension for it.

2. Type of Waterway

The dimensions of the domain will be affected by the amount of room which is available for manoeuvring. The less navigable space there is the smaller the domain will be. However, this study is concerned in particular with an ideal domain, with dimensions that enable a navigator to proceed without too much stress, so no systematic study has been made of the way the domain compresses. It is however expected that different results will be obtained for different sea areas, such as an open sea situation, the Dover Strait, or the Strait of Gibraltar.

If the waterway reduces to a narrow channel then the domain of the ship may well change in shape completely. Rule 25 of the collision regulations (1960) tells ships 'to keep to the right' when in a narrow channel. In this situation there may be less clear water left on the starboard side than the port side but in any case the main area of clear water will be ahead.

3. Density of Traffic

Just as the nature of the waterway will affect the domain, so similarly will the density of traffic in it. As density increases, so again the domain will increase.

4. Fixed Objects

If a navigator encounters a fixed object such as a buoy, a lightship or even a bridge then assuming that the navigator has some freedom as to how close he can approach, there will still exist a domain with respect to these fixed objects. The domain will obviously depend on the nature of the particular object but in general it will probably be smaller than for moving ships. The shape of the domain may well be altered too, particularly if the objects are in a narrow channel.

The exact form of the relationships between the size and shape of the domain and the various variables discussed above will be considered in Chapter 6. It should however be mentioned again that although the variables have been categorised into various types there will be a certain amount of interaction. For example, different personalities may well interpret the same weather conditions in completely different ways. Thus this project must be statistical in nature.

OTHER WORK ON SHIP DOMAINS

The next section in this chapter deals with the work by other people that has been done on ship domains.

Japanese Studies

The Japanese being the forerunners in marine traffic engineering generally, published the first papers dealing with the concept of a ship domain. A summary paper of their work on this is given by Fujii and Tanaka (1971)⁽²³⁾. They use the terminology effective domain, but define it in terms of the other ships in the area as "the domain around a vessel under way which most navigators of following vessels would avoid entering". As the domain belongs to one particular ship it however seems more sensible to define it in terms of the navigator of that ship.

The results for the sizes of the domains given are based on traffic surveys around the coast of Japan. They are expected to be rather different than any results obtained in this study as the areas considered contained traffic of a rather different nature than that in areas such as the North Sea and Dover Strait. For instance in the channels of Tokyo Harbour, most of the traffic is between 20-100 gross tons and in the Uraga Strait the majority of traffic is between 100-500 gross tons.

The situation has in any case been simplified by consideration of the area astern of the ship only and by assuming symmetry between the port and starboard sides of the ship. Fig. 2.2 below shows a domain as defined in the paper.

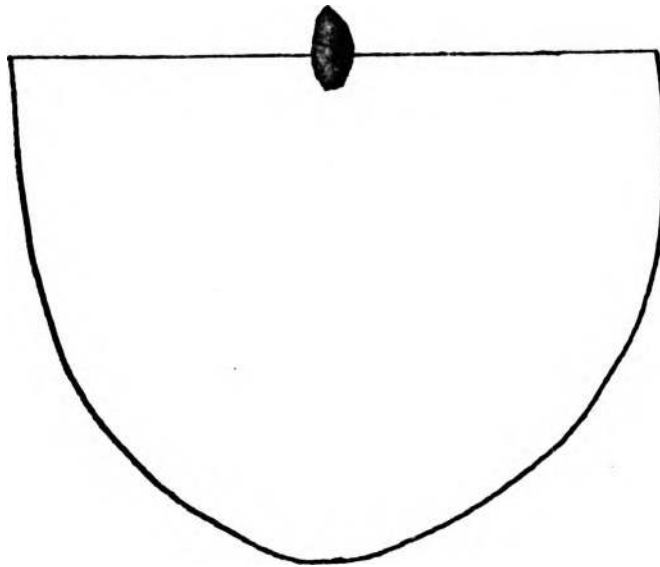

Fig. 2.2 The Boundary of a ship domain as a half-ellipse (23)

Its boundary is a half-ellipse. For ships of length between 230 ft. and 460 ft. in an area where all the ships have lengths between these values the dimensions of the ellipse were found to be: semi axis major - 1640 ft. approx. and semi axis minor: 980 ft. approx.

One of the aims of this thesis is to establish a suitable definition for the domain boundary and a full discussion of this is given in Chapter 5. It is concluded there that the definition of domain boundary suggested by the Japanese work is not in fact the most satisfactory.

Apart from the limited study in Japan, at this present time of writing, no other attempt appears to have been made to establish the clear water area which a ship needs for its safe navigation.

APPLICATIONS OF THE STUDY

In the final section of this chapter it is worth considering briefly some of the possible applications of the results. A fuller discussion of this aspect is given in Chapter 7.

1. Establishment of Controlled Routeing Systems

It is possible that ships could be guided through congested areas under direct control from a shore station similar to air traffic control procedures. The aircraft system is based on the maintenance of safe separation standards and in the marine systems the domains could provide a suitable basis for the separation standards there.

2. Studies of Encounter Rates

In the Dover Strait at the present time there is a mandatory traffic separation system. Papers considering the effectiveness of the scheme have looked at the encounter rates, defined as the frequency with which one vessel is within some specified distance of another (see Barratt (1973)⁽²⁴⁾ and Draper and Bennett (1972)⁽²⁵⁾). An overlapping of two domains could be considered an encounter, rather than the arbitrary values used in these papers.

3. Traffic Capacities

For many planning purposes it is useful to establish the traffic capacity of a channel. The basic traffic capacity of a channel can be thought of as the maximum number of ships which can negotiate the channel in a given unit of time assuming normal navigating conditions and ships of similar types. A knowledge of ship domains will help in establishing this.

4. Computer Simulation Models

Results about ship domains will help in studies of the behaviour of ships. Thus they will be useful in building computer simulation models of areas under study such as the Dover Strait.

These are only a few of the many applications that should be possible. It is however apparent that ships' domains are going to be an important consideration in the solution of the general problem of avoiding collisions between ships and yet still making the most effective use of the water area.

SUMMARY

In the first two chapters an outline has been given of the present situation in marine traffic engineering. The concept of a ship domain has been discussed together with its relevance to the wider topic. The next two chapters are concerned with the methods of data collection and processing used in the study. In Chapter 5 possible definitions of the domain boundary are discussed and using the most suitable definition results with different variables are given in Chapter 6. The final chapter considers applications of the results to certain problems, and some possible extensions of the project.

CHAPTER 3

The Collection of Data

SOURCES OF DATA

The two main sources of data for this study were

1. Records of the performance of ships' officers in exercises in collision avoidance on a marine radar simulator,
2. Traffic surveys conducted in an area of the southern North Sea.

Since one of the eventual aims of the study was to consider the dependence of a ship domain on the various factors outlined in the previous chapter it was necessary to be able to measure these variables as well as recording ship movements. Thus with this consideration, it was decided to use information on the behaviour of ships' officers in collision avoidance exercises on a marine radar simulator as one source of data. However, it is essential to validate results from simulated situations with some real life experiences so as a second source of data, some traffic surveys were conducted in an area of the southern North Sea centred on the Sunk lightvessel.

The two sources of data are treated in parallel in this and the following chapters. They will be referred to respectively for brevity as

1. Simulator data;
2. Sunk survey data.

The present chapter will describe the collection of primary data, and in the next chapter the methods of processing the primary data to produce the secondary data for the analyses will be considered. A discussion of the inadequacies of the data both inherent in it and arising in its collection, will also be given in the next chapter.

A. DATA FROM THE MARINE RADAR SIMULATOR

EQUIPMENT

The simulator from which the records were taken was the City of London Polytechnic's Solartron radar simulator. It is a 'three own ship' simulator consisting of three separate booths each equipped with a radar display and controls by which the student, or group of students,

can alter the speed and course of the ship which he is navigating. An additional control which can be preset for each own ship by the instructor allows the speed and manoeuverability of a ship to be altered to correspond to the particular type of ship being simulated.

The instructor from his master console has up to four moving target ships and other stationary targets over which he has direct control. He is also able to decide independently for each of the three booths what should be shown on their radar screens. Thus in some of the exercises the students do not see each other's ship on the screen, only the instructor-controlled target ships, but in some of them they see the target ships and additionally, the other students' ship. The instructor, however, can in all exercises, monitor the heading and speed of all the students' ships at his console. The positions of all the ships in the area may be taken from digital voltmeter readings in the form of X, Y co-ordinates. This is an accurate method of recording but necessitates the presence of an experimenter to record these throughout the exercise, which would be a very lengthy process. The simulator, however, incorporates a Kelvin-Hughes 'photoplot' device, whereby a filmed recording of the whole exercise is made and then a projection of the positions of all the ships in the playing area at selected intervals can be shown. At the initial stages of the work, attempts were made to analyse the progress of an exercise directly from the film; however, this proved to be very time-consuming as the films were analysed some time after the exercises had taken place, so that irregularities which sometimes occurred in the filming process were difficult to take account of. The most satisfactory method of recording the exercise was therefore found to be to note a tracing of the complete exercise from start to finish immediately after it was over.

Further details on the simulator performance are contained in Appendix III page 199.

THE EXERCISES

Ships' officers at varying stages of their careers come to the Polytechnic for a week's course in radar methods of navigation. The exercises are all on collision avoidance and are assumed to take place in fog with visibility of $\frac{1}{2}$ nautical mile, since this is a typical situation when a navigator must rely on his radar display and not on visual observations.

For each exercise there are usually two students per booth; one of them has responsibility for navigation and the other is there in a supporting role. In the analyses of the movements with respect to experience, it is always the experience of the student actually with responsibility for navigating that is taken in this study.

At the start of the course the navigating students in all three booths are placed in identical situations in identical ships in an open ocean and the task is to avoid the target ship or ships controlled by the instructor. For these early exercises the student will only see the echoes of the target ship or ships on his own screen. An initial situation for one of the exercises of this type is given in Fig. 3.1. The students all start at point A on a heading of 070° in ships of 10,000 g.r.t. with an initial speed of 8 knots but a full speed of 16 knots. There are three target ships starting separately from points B, C and D and the arrows denote an hour's track if there were no alteration of course and speed. The way the situation developed for one set of students is given in Fig. 3.2 which shows the positions of each of the ships at six minute intervals after the start of the exercise. Although the basic alteration of course was the same for each student there is obviously a considerable amount of variation in their attitudes to the threats of the target ships as the timings of the alterations and the speeds throughout the exercise were very different.

In the later exercises, the students have a choice of the type of ship they want to manoeuvre and their task is to navigate through an area such as the Strait of Gibraltar or the Dover Strait. In these exercises the student will see on his radar screen the echoes of the ships controlled by the other students as well as those controlled by the instructor. During the exercise the student keeps a record of his manoeuvres and his reasons for any alteration of course and speed which are useful in looking at the completed traces later. Figs. 3.3 and 3.4 show an initial situation and then its development on one occasion for an exercise in the Strait of Gibraltar. The destinations, initial headings and initial speeds are all given in Fig. 3.3. For the particular set of students recorded in Fig. 3.4, own ship 1 was of 20,000 g.r.t., full speed of 15 knots and initial speed of 7.5 knots; own ship 2 was of 18,000 g.r.t., full speed of 16 knots and initial speed of 8 knots, and own ship 3 was of 20,000 g.r.t., full speed of 22 knots and initial speed of 11 knots. The use of change of speed

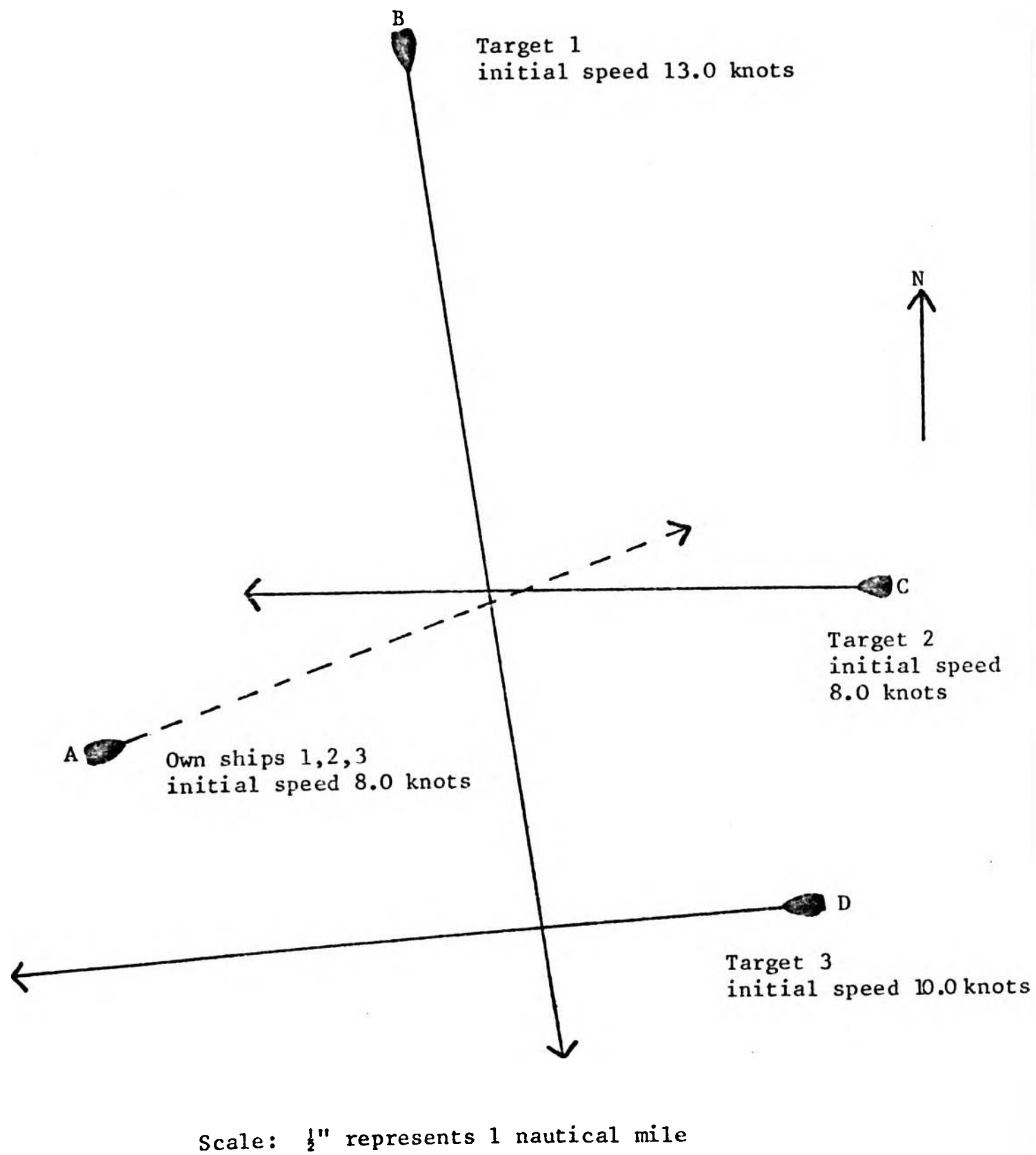

Fig. 3.1 Open Ocean: Exercise 6: Initial Situation

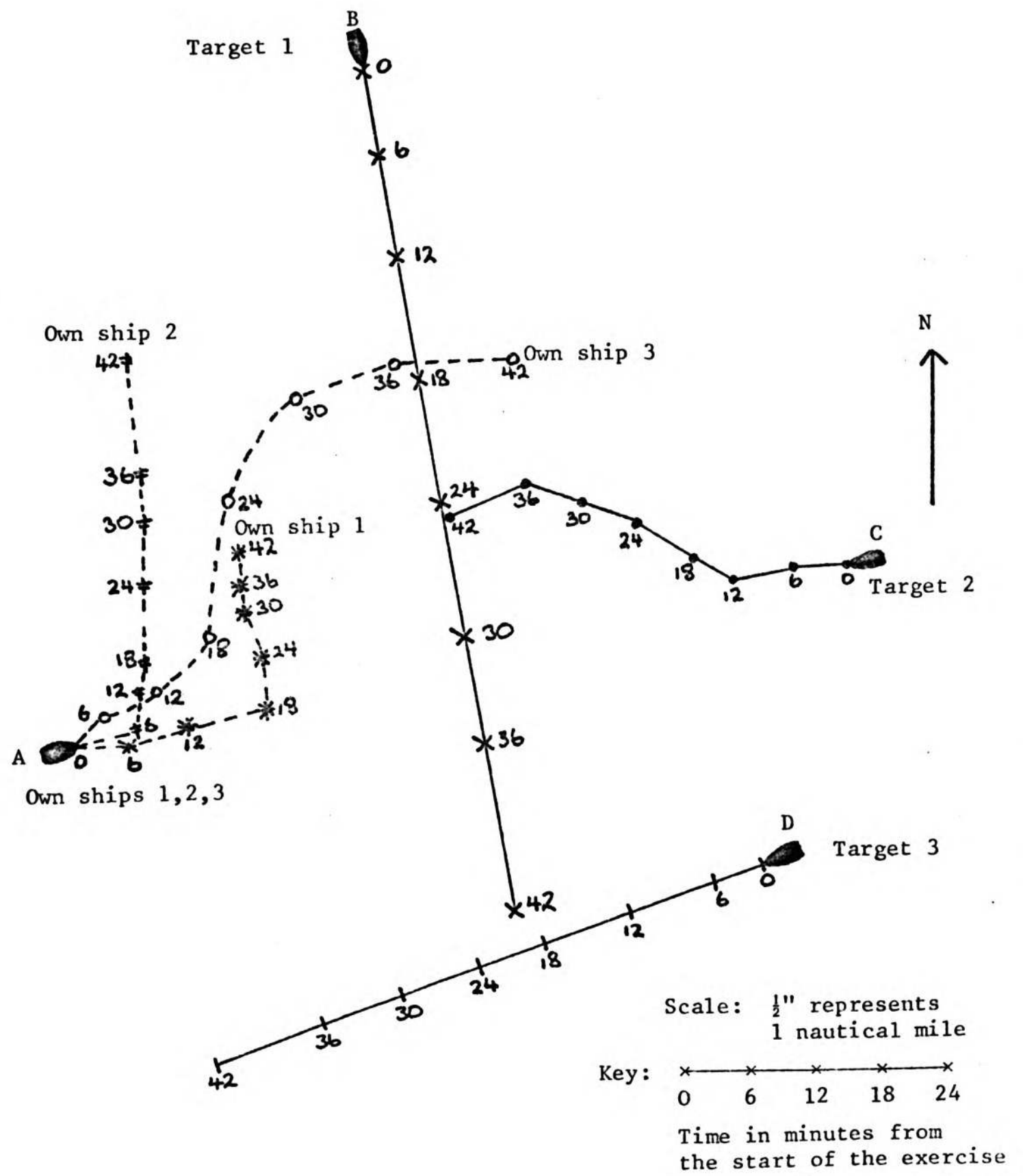
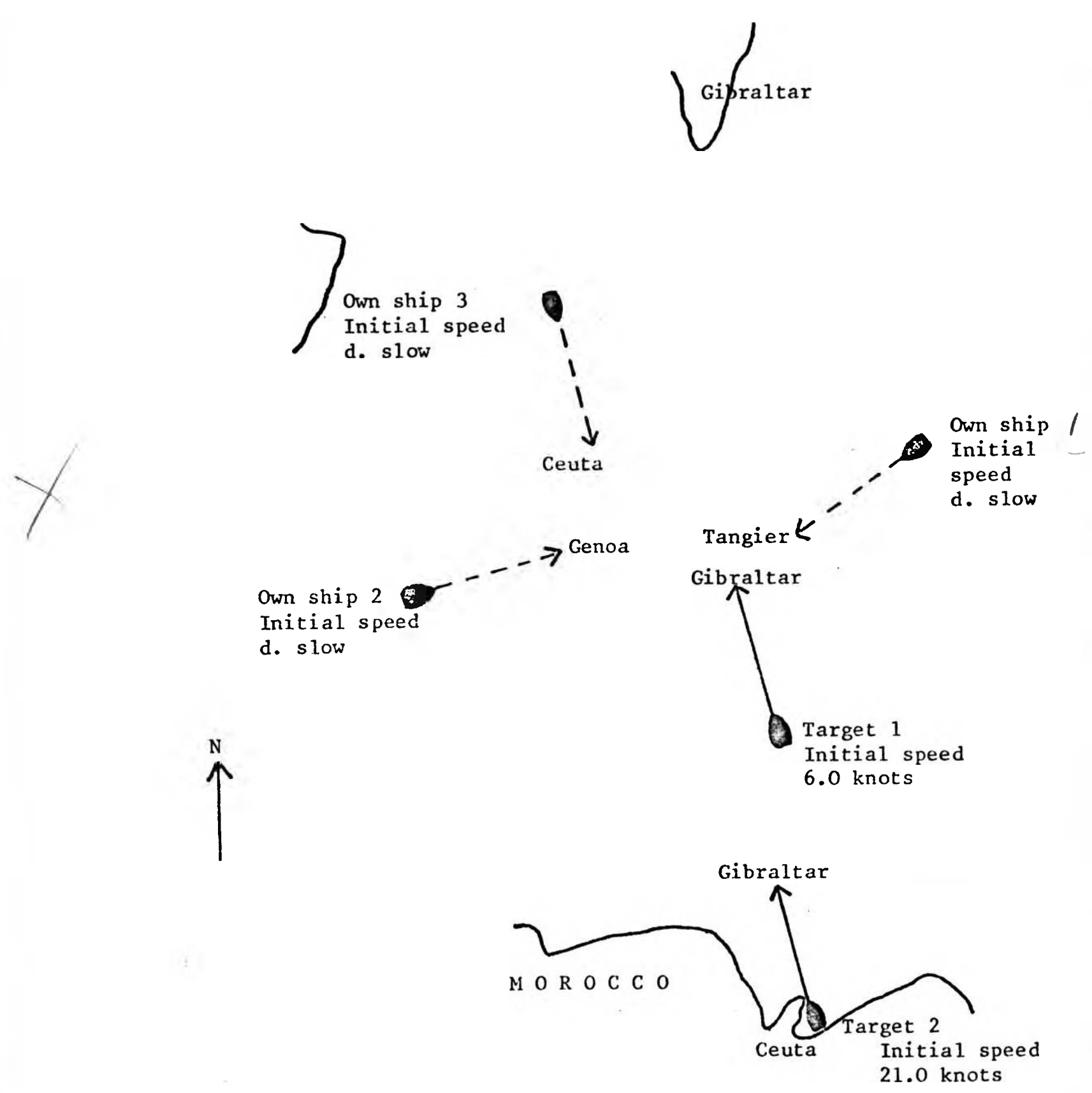

FIG. 3.2 Open Ocean: Exercise 6: One Development of the Situation



Scale: $\frac{1}{2}$ " represents 1 nautical mile

FIG. 3.3 Gibraltar Strait: Exercise 10: Initial Situation

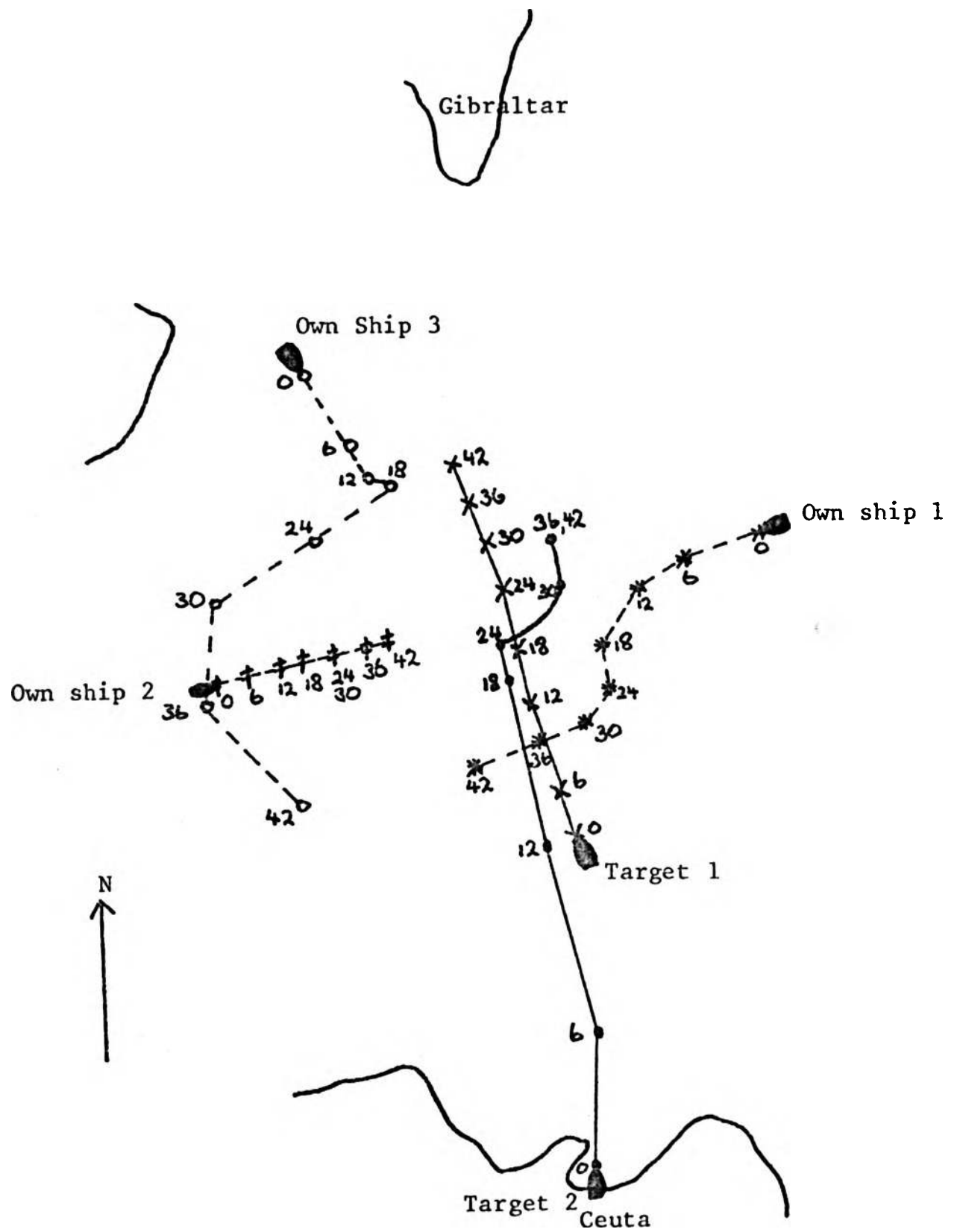
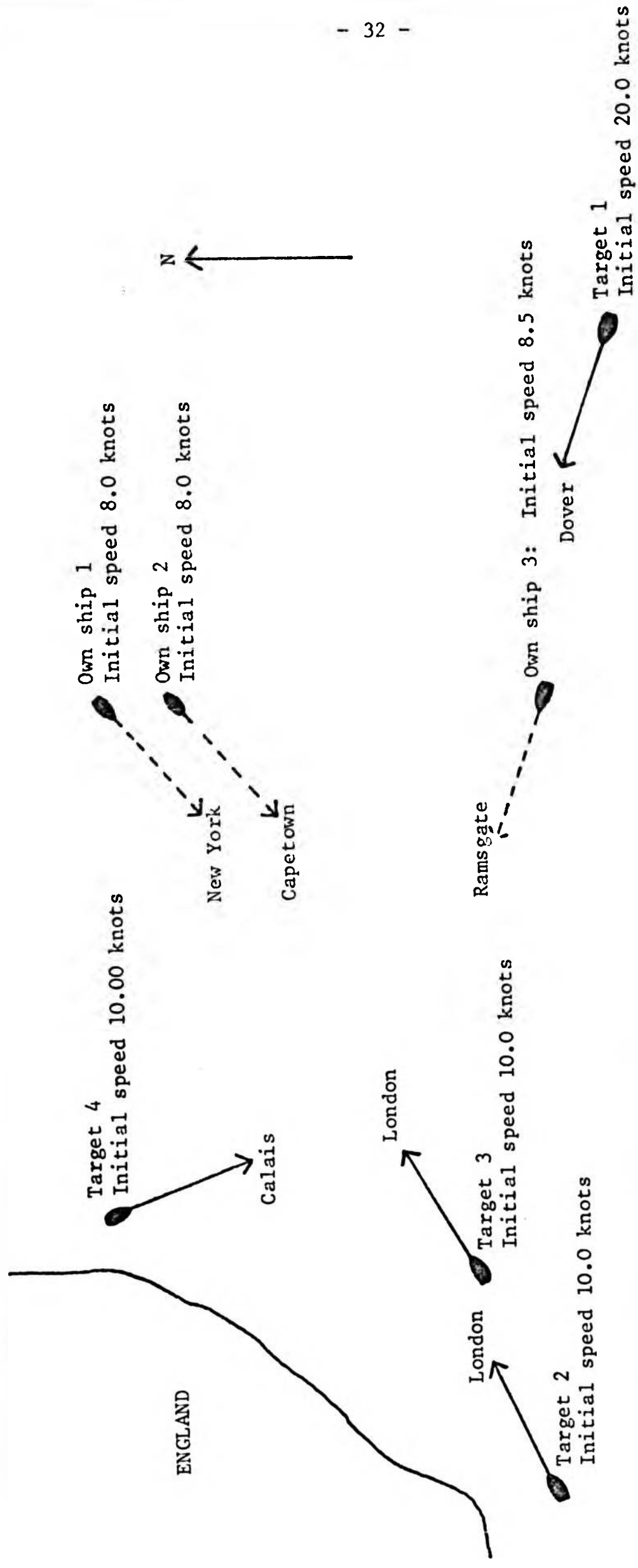

FIG. 3.4 Gibraltar Strait: Exercise 10: one development of the Situation



Scale: 1/2" represents 1 nautical mile

FIG. 3.5 Dover Strait: Exercise 20: Initial Situation

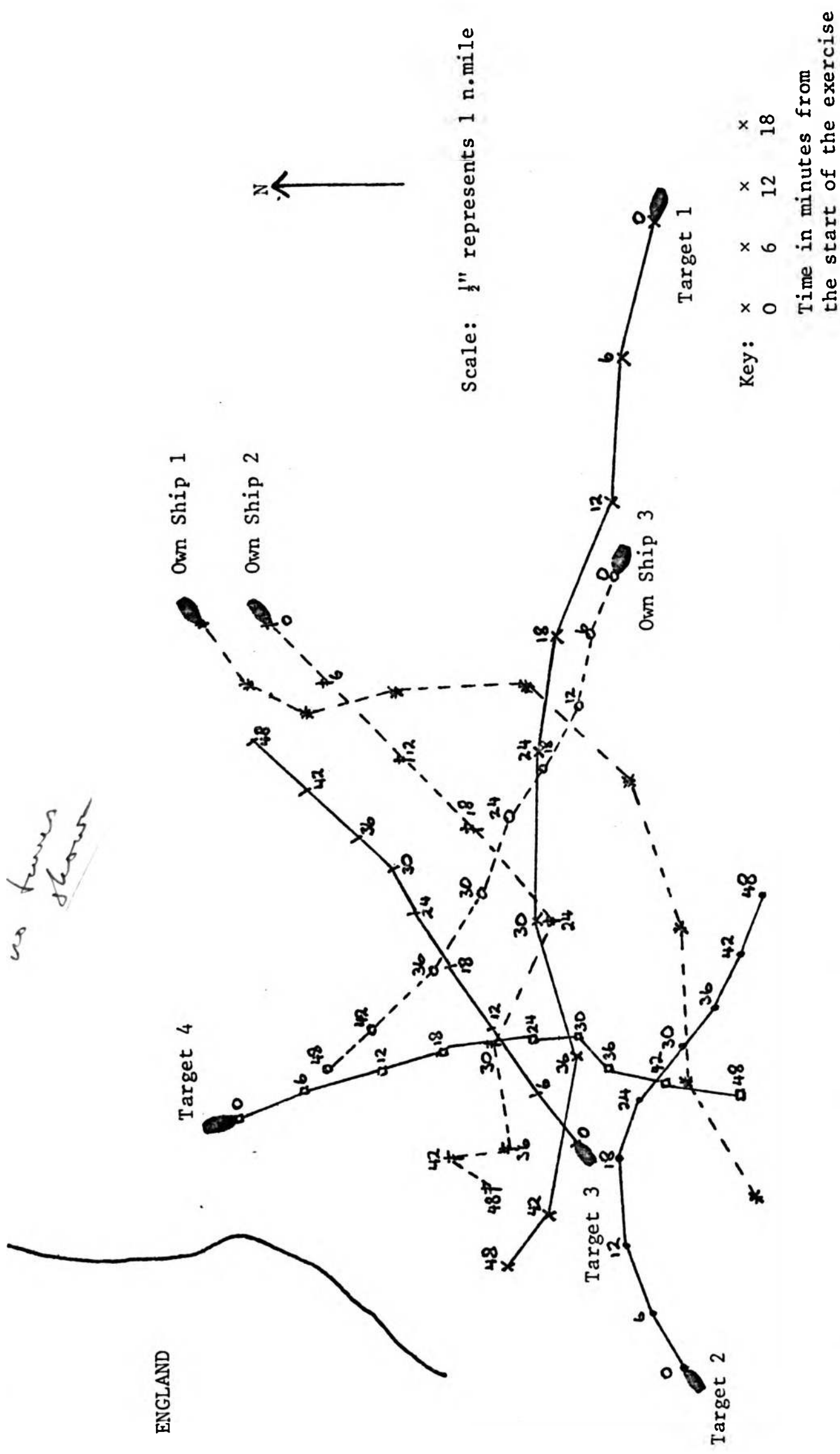

FIG. 3.6 Dover Strait: Exercise 20: One Development of the Situation

as well as change of heading in manoeuvring is illustrated well here.

Similarly, Figs. 3.5 and 3.6 depict an initial situation and its development on one occasion for a Dover Strait exercise. The Dover Strait exercises are generally the most complicated.

The own ships depicted were:

| Number | Size (g.r.t.) | Full Speed (knots) | Initial Speed |
|--------|---------------|--------------------|---------------|
| 1 | 13,000 | 30 | 9 |
| 2 | 10,000 | 21 | 10.5 |
| 3 | 500 | 12 | 8.4 |

From these traces, illustrations of typical ship manoeuvres according to the collision regulations under these sorts of conditions, can be seen. For instance in Fig. 3.6, consideration of own ship 2 and target 2 shows that both altered to pass on the port side, whereas maintaining course and speed would have resulted in a passing on the starboard side. This same manoeuvre can be seen between ship 1 and target 2.

The radar pictures for the coastal situations are very realistic as Fig. 3.7 shows. This is a typical picture at some point during a Dover Strait exercise. Some of the echoes are the ships but others are the buoys and lightships in the vicinity. In particular the Kent coastline and Dover harbour are very prominent.

The diagrams of the initial situations of the other exercises analysed in this study are given in Appendix III. They are subdivided into the three basic types of situation outlined above; viz. Open Ocean, Strait of Gibraltar and Dover Strait, examples of which have all been discussed above.

Figs. 3.2, 3.4 and 3.6 are all drawn on a scale of $\frac{1}{2}$ " representing 1 nautical mile and are half-scale representations of the actual tracings of the exercises. The tracings were all made on a scale of 1 inch representing 1 nautical mile onto rolls of transparent cellophane paper.

MEASUREMENT OF THE VARIABLES

The tracings described above provided the raw data from which information on the ships' movements and speeds could be obtained. The methods of doing this are considered in the next chapter. For each



FIG. 3.7 The radar Display for an Own Ship on the Radar Simulator at Some Point during a Dover Strait Exercise



FIG. 3.7 The radar Display for an Own Ship on the Radar Simulator at Some Point during a Dover Strait Exercise

exercise, a record was kept of the size of each own ship in gross registered tons and the maximum speed in knots the ship was capable of. Records were also available of the date of birth of the students participating in the courses. A rough estimate to the nearest year of the sea-experience of each student could therefore be made, assuming that the age of starting sea training was 17. It was therefore possible to relate the experience of the navigating officer to the other information on each own ship.

Since the target ships are controlled by instructors who continually repeat the same collision avoidance situations, it was felt that the movements of the target ships themselves should not be analysed. They are obviously considered indirectly, however, as their movements affect the movements of the own ships. Thus the variables just mentioned, such as experience of the navigator, and the size and maximum speed of the ship were not recorded for the target ships.

THE TOTAL SAMPLE

In all, plots of 70 exercises were taken to be analysed. Of these, 43 were of open ocean exercises, 19 were of Gibraltar Strait exercises and 8 were of Dover Strait exercises. Since each exercise contains three own ships, then this should, in theory, have produced information on 210 own ships in all. However, the total was actually 207 as 3 could not be analysed. More detailed information on the make-up of the sample by type of exercise is given in Appendix III. The distribution of the length of sea-experience of the 207 officers is given in Table 3.1.

| Length of Experience (years) | Number of Officers |
|------------------------------|--------------------|
| 8 years and under | 30 |
| 9 - 11 years | 55 |
| 12 - 14 years | 12 |
| 15 - 19 years | 22 |
| 20 - 26 years | 29 |
| 27 years and over | 45 |
| Not known* | 14 |
| TOTAL | 207 |

* Notes (see p.320)

TABLE 3.1 Distribution of the Length of Sea Experience of the Ships' Officers in the Simulator Exercises.

The range of sea-experience was from 6 years to 41 years. The attendance at a radar simulator course is an essential preliminary to obtaining a D.T.I. Master's certificate which partly explains the large numbers in the younger age groups. An additional explanation is that the parent population of all Merchant Navy Officers shows a similar skewness due to heavy wastage from the industry. For the older officers the course is more of a refresher nature and many of these officers will have attended similar radar simulator courses on a previous occasion. The experience of groupings shown in Table 3.1 were chosen so that the midpoints of each class would be representative of the class and could be used in subsequent analyses. They were either natural cluster points or if the experiences were evenly spread over a range, they were the midpoints of that range. The final category of not known included one person who was lecturing at a nautical school in Germany and a second who was a nautical advisor to the Australian government. As they were both in shore jobs it was felt that they should be treated separately as regards sea-experience.

It should also be pointed out that since this table refers to the number of own ships, the experience of any one person will be represented in the table as many times as that person performed an exercise that was analysed. Thus the figure 14 under 'not known' contains 6 own ships for which the records were not available and 8 own ships controlled by either of the 2 subjects mentioned above.

Table 3.2 shows the distribution of the size of ship by gross registered tonnage for the own ships in the exercises.

| Gross Tonnage | Number of Ships |
|------------------------|-----------------|
| 4,000 g.r.t. and under | 17 |
| 5,000 -9,000 g.r.t. | 9 |
| 10,000 g.r.t.* | 131 |
| 11,000 - 18,000 g.r.t. | 14 |
| 20,000 - 45,000 g.r.t. | 16 |
| 50,000 -100,000 g.r.t. | 16 |
| Not known | 4 |
| TOTAL | 207 |

* Notes (see p. 320)

TABLE 3.2 Distribution of the Gross Tonnage of the Own Ships in the Simulator Exercises

The range of tonnage was 500 g.r.t. to 100,000 g.r.t. and the groupings were again chosen with reference to the midpoints of the groups. The large number of ships of 10,000 g.r.t. arises because this is the size of ship used in the early exercises (nos 1-7) when all three students are placed in identical ships. The distribution is obviously not typical of the distribution of ships in any one area, but is probably typical of the distribution of ships for which the students are navigators.

The distribution of the maximum speeds of the own ships in the exercises is given in Table 3.3

| Maximum Speed (knots) | Number of Ships |
|-----------------------|-----------------|
| 10 - 12 knots | 12 |
| 13 knots | 18 |
| 14 knots | 20 |
| 15 knots | 11 |
| 16 knots* | 107 |
| 17 - 19 knots | 11 |
| 20 knots and over | 25 |
| Not known | 3 |
| TOTAL | 207 |

* Notes (see p. 320)

TABLE 3.3 Distribution of the Maximum Speed of The Ships in the Simulator Exercises

The large number with maximum speed of 16 knots is again caused because all the early exercises take place in identical ships. The largest maximum speed for any ship was 30 knots.

B. DATA FROM THE MARINE TRAFFIC SURVEYS

The marine traffic surveys were carried out on board the M.V. 'Sir John Cass', the research vessel of the School of Navigation at the City of London Polytechnic. The 'Sir John Cass' is a 154 ton ship of 100 feet in length and is mainly used in the River Thames for radar training. She is, however, equipped for oceanographic research and at various intervals during the summer she is made available for research projects for periods of up to one week. There are three radar screens on board for teaching purposes, so it is possible to use one for a survey without hindering the navigation of the ship in any way.

THE SURVEY AREA

The area in which the surveys were conducted is in the North Sea about 12 miles from Harwich and centred on the Sunk lightvessel there. Fig. 3.8 is a sketch map of part of the East Coast and shows the position of the Sunk lightvessel with respect to the main coastal towns in the vicinity. The London District pilot vessel cruises near the light vessel and ships travelling to and from the Thames Estuary have to take on or drop a pilot at this point. These will include ships of all types on routes between the Thames ports and the Northern European ports and also very large ships approaching from the English Channel for which the Edinburgh channels in the south of the estuary are not deep enough. There is also traffic going into and out of Harwich and Felixstowe passing through this area and other traffic travelling along the East coast. The survey area covers an intersection of routes from East coast ports to North-West Europe and the English Channel and thus has a high traffic density, with traffic converging from all directions.

Fig. 3.9 is a large scale sketch map of the exact area covered in the surveys. The positions of the buoys and other fixed objects in the area are marked. Apart from the Sunk lightvessel, the other obvious feature was one of the old wartime forts known as the Roughs Tower. Figs.III.17 and III.18 in Appendix III are reproductions of the navigational charts from which the two sketch maps given here have been taken. By reference to them it is possible to get some idea of the sort of navigational area the survey area represents. The approach to Harwich and Felixstowe is along a buoyed channel, which can be seen in Fig. 3.9, so it is possible to consider movements in such a channel as well as under open sea conditions. Another interesting feature of the area is that it includes some good fishing grounds indicated by the presence on

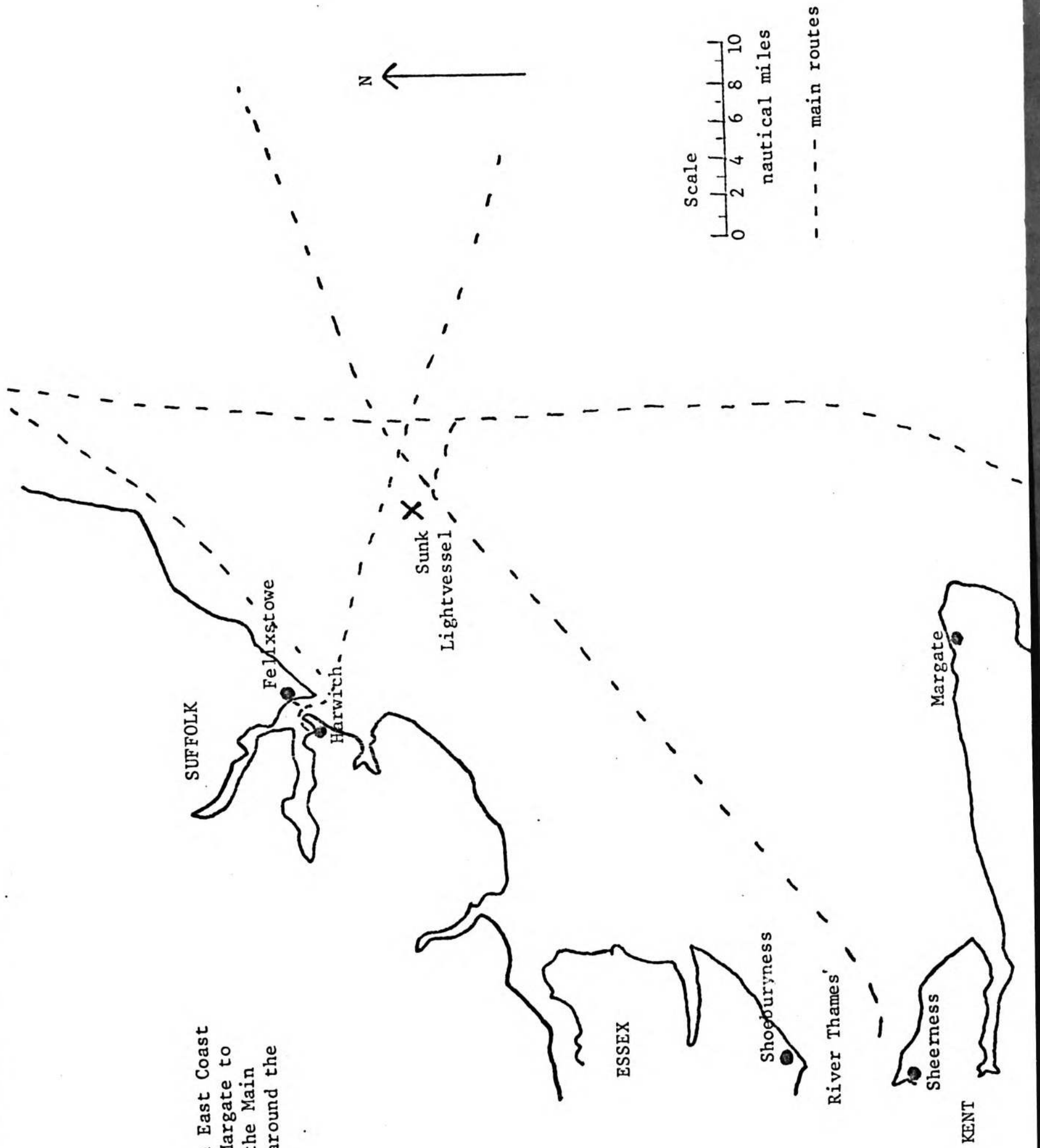

FIG. 3.8
Sketch Map of the East Coast
of England from Margate to
Felixstowe with the Main
Shipping Routes around the
Sunk Lightvessel

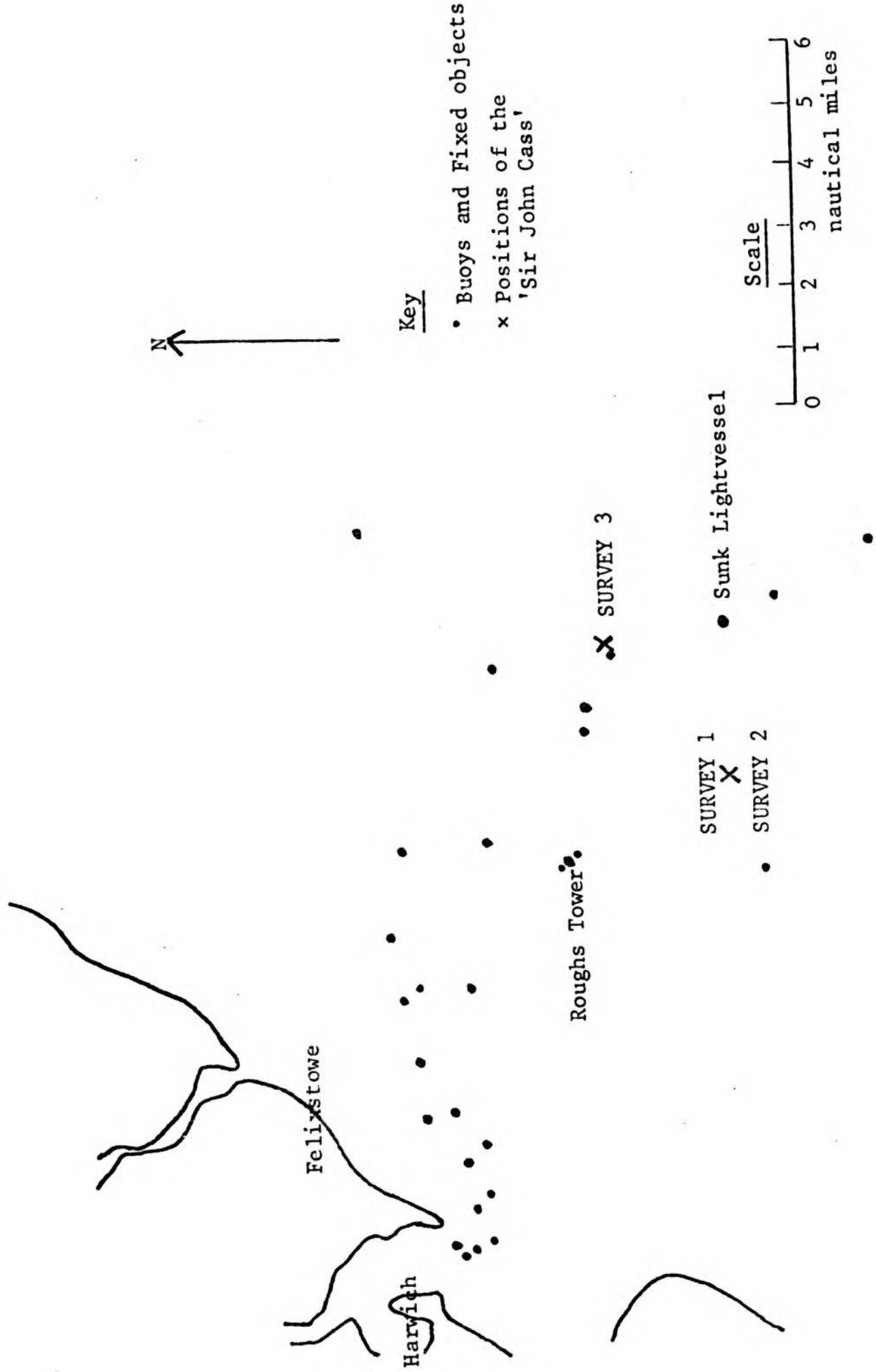

FIG. 3.9 Sketch Map of the Survey Area for the Three Traffic Surveys

each survey of several fishing boats. Thus data could be obtained on the behaviour of other vessels towards fishing vessels. It was felt however, that the actions of a British fisheries protection vessel on one survey in 1972, ensuring that the Belgian trawlers did not stray over the existing 12 mile coastal boundary could not be included in the same way as other ships!

It is thus apparent that the survey area was a very suitable one both in its variety and the nature of the traffic. It was also a very practical area in terms of time and cost. It could be reached easily from London, so that work could start on a Saturday afternoon having left London on Friday evening with an overnight stop at Sheerness. If bad weather blew up, as it did frequently, Harwich was nearby for shelter. Additionally it was an area which was being studied geologically by other members of the Polytechnic so it was possible to combine two research projects without extra expense. As a source of validating data for the results from the simulator it would have been better if the survey area could have been the same as one of the simulated areas. However, it is still possible to compare the results to a large extent so this is not a very important drawback. It is hoped at a later stage that it may be possible to apply the ideas developed in the thesis to study different areas.

THE SURVEY METHOD

The basic method used in the survey was to photograph a 3 cm (wavelength) marine radar display every three minutes for as long a period as possible. The films were then projected at a later date and the tracks of the ships through the area plotted.

THE RADAR

The radar used was a Marconi Radio-Locator 16. Some technical details on it are given in Appendix III. To eliminate external light a radar hood was secured over the screen and a wooden cradle was fixed at the top of this to hold the camera allowing room only for the camera lens. A picture of this structure is given in Appendix III.

PHOTOGRAPHY

A Praktica single lens reflex camera with a 50 mm lens was used loaded with a 35 mm, 36 exposure black and white film. A fairly slow film was used with ASA 125, Diñ 22.

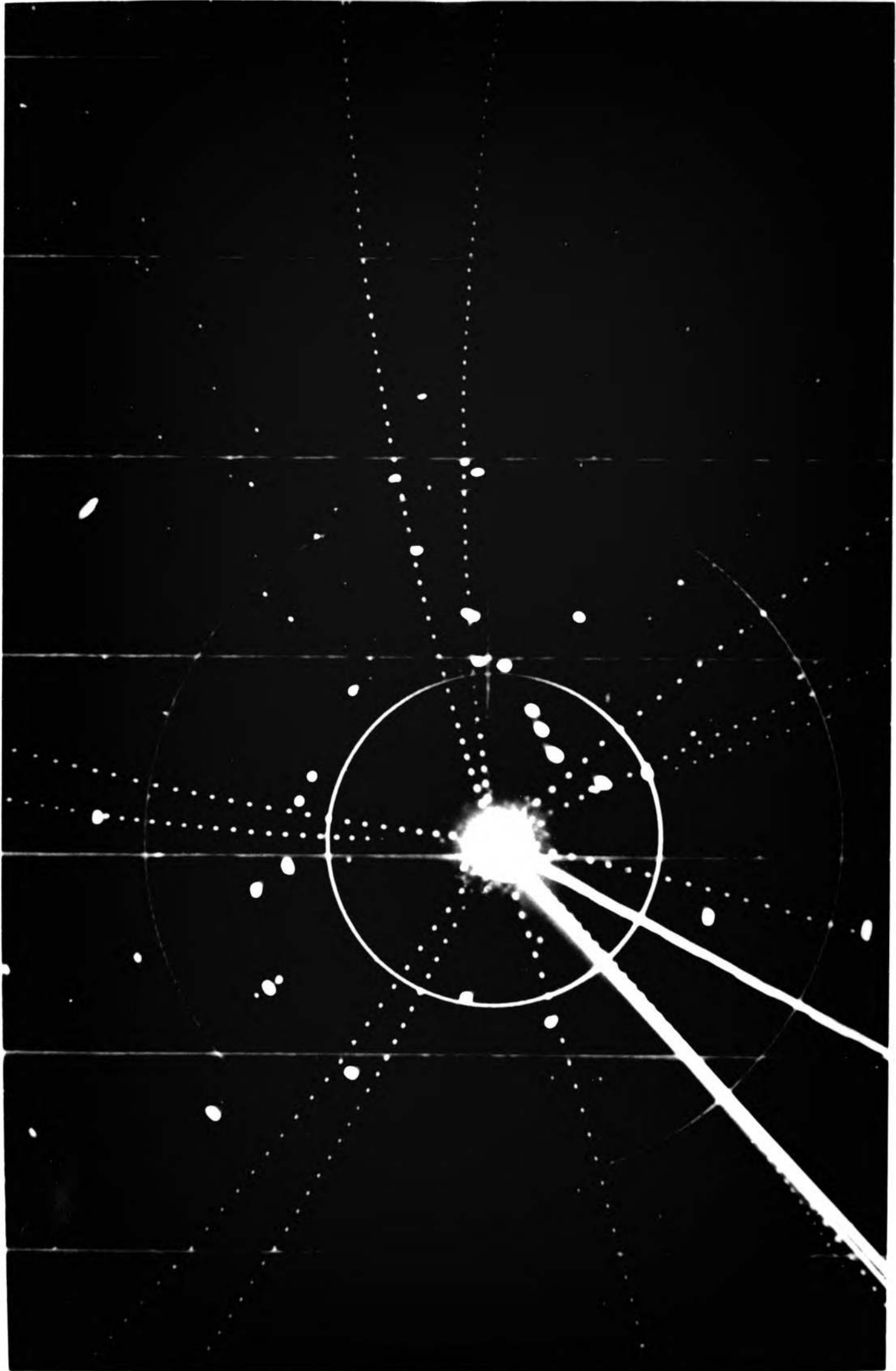

FIG. 3.10 The Radar Picture at 00.30 on 21.5.72. Sunk Survey 1. (Light setting f.5.6, exposure time 6 secs).

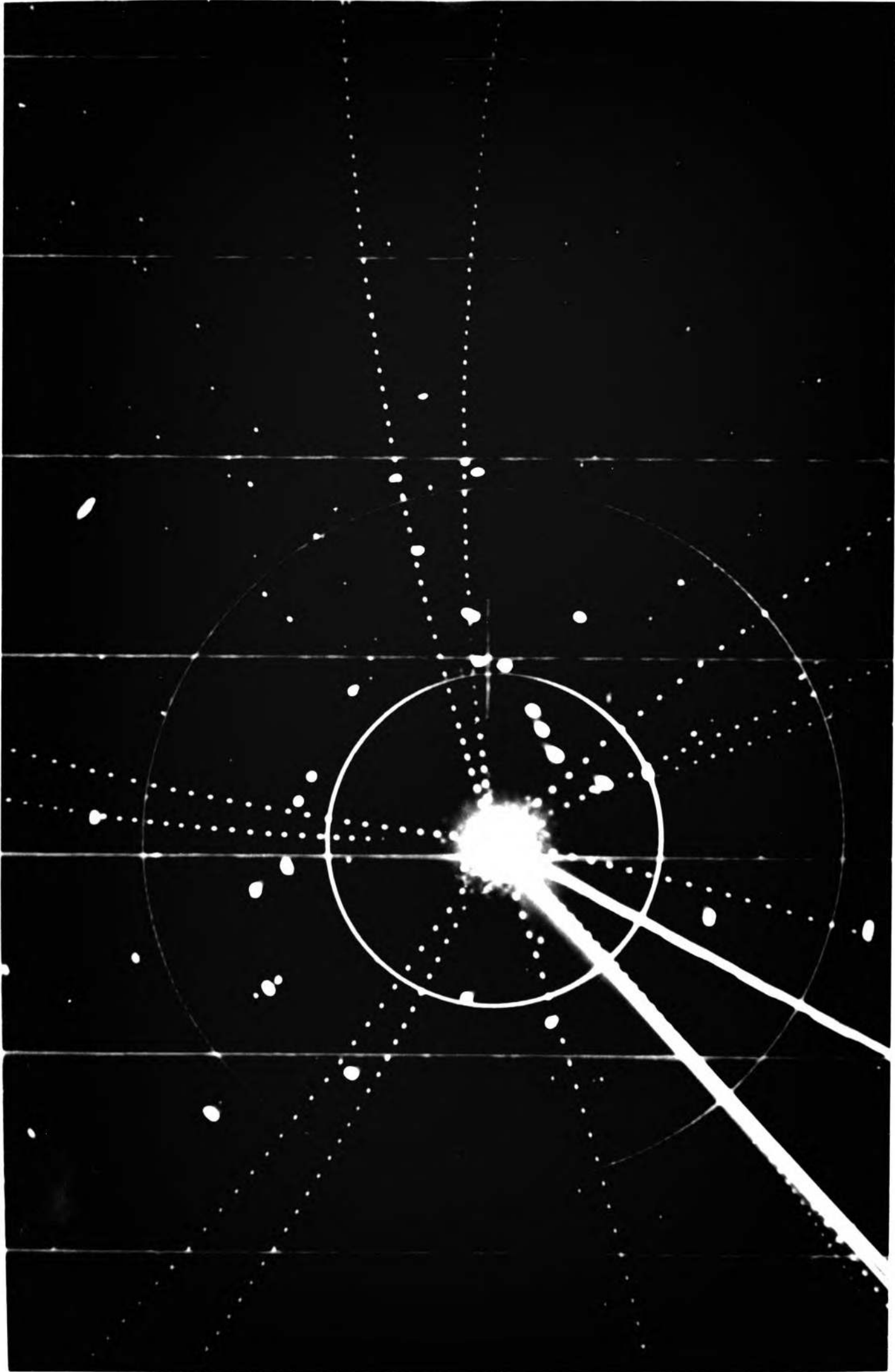

FIG. 3.10 The Radar Picture at 00.30 on 21.5.72. Sunk Survey 1. (Light setting f.5.6, exposure time 6 secs).

Fig. 3.10 is a typical example of the type of photograph produced. The light setting on the camera was f5.6 and the exposure time was 6 seconds, during which time the radar completes nearly 3 scans. It was hoped that by taking more than one revolution of the scanner some of the interference effects would be reduced. The interference consists of a pattern of very bright dots over the whole of the screen but it does not repeat in the same position on successive sweeps. It is caused by other radars in the vicinity operating at conflicting frequencies. The actual form that the interference from one particular radar takes depends on the difference between the operating frequencies: the closer together, the more regular the pattern; the further apart, the more random it becomes. Thus a variety of interference patterns were observed, because of the number of ships and also because of a land station nearby. Although the interference was not removed, it can be seen in Fig. 3.10 that the echoes show up very strongly against it so it did not cause many problems when preparing the plots later.

The radar display was set on a 12 mile range to cover a reasonable sea area but with adequate discrimination between echoes. It was thus possible to distinguish between two ships whose nearest passing distance was under 1 cable (.1 nautical mile).

During the first survey photography went on both while the ship was cruising in the area and while it was at anchor. However, the subsequent plotting was very much easier using the results from the period when the ship was at anchor so for the later surveys, observations were only made when the ship was stationary. Apart from the plotting advantages of keeping the frame of reference constant, this also meant that moving targets were very easy to distinguish. In Fig. 3.10 the tadpole-like echoes are all moving ships, the tail being caused by the afterglow on the screen known as the 'trail'. The trail indicates relative movement with respect to the survey ship and if she is moving then the buoys and other fixed objects will also have trails if relative motion is shown on the P.P.I. The trails were particularly noticeable throughout the survey pictures because of the long exposure per picture and the relatively large range scale of 12 miles.

One frame was used every 3 minutes throughout the later surveys since it was found that a 6 minute interval used in the first survey made it more difficult to follow particular ships from frame to frame especially

when there were several in one area simultaneously. Additionally if one frame was spoilt with a three minute interval, then the tracks could still be picked up but with a six minute interval this became very difficult. To identify individual frames in a roll the bearing marker was turned through 10° each frame. Thus in Fig. 3.10, where the bearing marker (the thin white line) is at 210° , this photograph was no. 21 in the particular roll. This was a very useful feature when plotting at a later date.

IDENTIFICATION OF SHIPS

During each survey, notes were kept of any ships which were observed from the 'Sir John Cass' and also of any irregularities in the photography. These again proved useful in the plotting stages. Identification of ships was however not very easy at the time as few ships came close enough for the names to be read. It is also very difficult to deduce anything about the size of ship from the size of its echo painted on the P.P.I. display. The aspect of a ship with respect to the scanner will obviously affect it so that a large ship head-on can appear smaller than a small ship beam-on. In any case there is distortion so that there is no simple relationship between the size of echo and the size of ship. Some types of ship could however be identified by their movements on the display. Thus the pilot vessel was always easy to identify and similarly fishing vessels could be spotted by their seemingly random paths.

Identification of many of the vessels was made possible at a later stage with the help of the Harwich pilot station. Records were available there of the movements of pilots both from the Sunk pilot vessel and the Cork pilot vessel which provides the pilots for ships entering Harwich. The records were kept for embarkation and disembarkation of pilots and included the name of the ship and the time at which the transfer occurred.

Before continuing with the discussion of the survey methods, it is worth considering Fig. 3.10 again from the question of identification of targets. This photograph was taken at 00.30 on 21 May 1972, the time of the first survey. The 'Sir John Cass' was anchored about 2 miles due west of the Sunk lightvessel which is the lower of the two echoes in the centre of the picture. To the north-west roughly of the 'Sir John Cass' the pattern of three echoes is the Rough's Tower and its two flanking buoys. The pilot vessel is SSE of the survey ship exactly 2 miles distant and at that instant there are several ships converging for pilots. The small echoes to the east of the Sunk lightvessel are fishing boats just about on the 12 mile coastal limit!

PLOTTING OF SHIPS' TRACKS

By projection of successive shots, traces can then be made of the movements of the ships during the period. The films were developed into film strips of negatives and these were projected onto large sheets of white paper. The stationary objects provided a frame of reference for lining up successive pictures. A scale of 5 cm to 1 nautical mile was used which produced a reasonably good level of definition. It was, however, essential to keep the projector firmly fixed to maintain the scale. Fig. 3.11 shows a typical series of traces obtained from 04.51 to 05.51 on 3.7.72, the date of the second survey. An hour's movements was found to be the most convenient per sheet, otherwise the plots became too complicated, but for continuity the final frame in each hour was projected again as the first frame in the subsequent hour. A colour code was used to identify each separate point in time but for clarity in this diagram only the six minute interval points have been shown. The diagram illustrates well the intersection of routes through the area.

DIFFICULTIES IN USING RADAR PHOTOGRAPHS

Although a critical discussion will be given at the end of the next chapter (p. 78) on the traffic surveys as a source of data for the particular project in question, it is worth considering briefly at this stage some of the practical problems which can arise generally in the use of radar but which therefore made the preparation of plots more difficult in this case.

The main problems encountered were:-

1. Radar interference.
2. Side-lobes.
3. Sea-clutter.

Very occasionally examples of two further phenomena were seen viz:-

4. Multiple Echoes.
5. False or indirect echoes.

Of these, radar interference patterns were nearly always present as has already been discussed (p. 44). In general it did not present many problems as it was reasonably recognisable. Even if on an initial frame there was some doubt, since the interference patterns are random the situation can be resolved in subsequent frames.

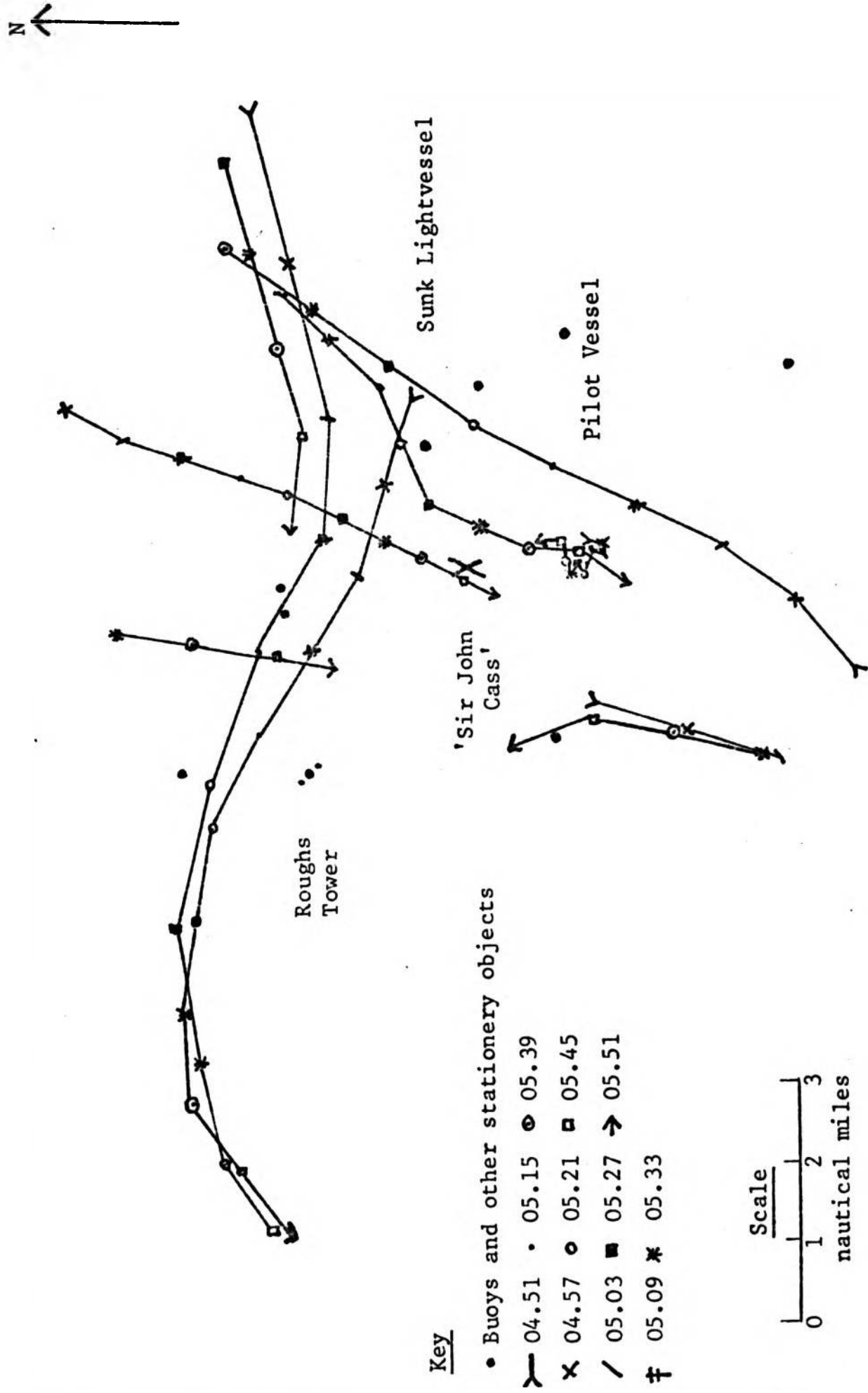

FIG. 3.11 Tracks of Vessels Through the Survey Area: 3.7.72 04.51 - 05.51 Sunk Survey 2

Side-lobing is an effect whereby the edges of a target are drawn out in an arc of a circle on both sides of the true echo. The main problems which it presents are firstly, to plot the exact position of the target and secondly, it may conceal another target. However, as this effect is most likely at close ranges there will be information from the frames immediately adjacent to help resolve the two problems.

The third major interference phenomenon was sea clutter which arises when the sea is rather rough and takes the form of small white dots often obscuring the centre of the radar screen. This proved to be one of the most difficult problems as the positions of ships when passing through the clutter could not always be precisely determined.

A further discussion on these aspects is given in Appendix III together with examples of their occurrence during the Surveys.

OTHER MARINE SURVEY METHODS

Having described the particular survey methods used in this project, they should be compared with methods used in some other surveys where information was required on ship movements.

Various surveys have been conducted in Japan and the most common method has been to photograph a 3 cm marine radar display every minute (or half-minute) with a specially designed 16 mm cine camera⁽²⁶⁾. Fujii and Tanaka (1971)⁽²³⁾ describe a method called a Programmed Radar Photograph method whereby six frames of 35 mm film are exposed every minute by an electrically operated camera. Photographs are then produced showing the wake lines of the ships omitting some of the shots to give the direction of them.

The National Physical Laboratory have been making a continuous photographic recording of the traffic in the Dover Strait by filming a 3 cm radar display with an offset range of 16 miles based at the coast-guard station at St. Margaret's Bay. This too has been done using a 16 mm cine camera exposing one frame automatically every minute.

It was felt that for the purposes of this project the more costly procedures mentioned above were not justified. For the analyses which will be described later it was decided that, for any one ship positions should only be taken at six minute intervals (see p. 78). The density of traffic was such that a three minute interval was sufficient to

trace ships easily so additional information was not absolutely necessary. By preparing the plots at a later stage it was also relatively simple to recognize the positions of all the ships in an area at a given point in time as well as keeping the movement of any one particular ship clear.

Another survey which has recently been conducted in the Hook of Holland Roads, and is to date unpublished, has used a different method of collecting the radar observations. It was conducted by the Dutch Directorate of Pilotage and has records of ship movements plotted directly as they occur from the radar screen. It is obviously impossible to record the position of each ship at any point in time so only changes in course are marked together with the time at which this happened. This has the advantage that any irregularities can hopefully be sorted out at the time but the disadvantage that if anything is missed one cannot go back in time.

It is hoped that data from both the NPL Survey and the Dutch pilots Survey will be made available for one of the projects envisaged as an extension of this current work. Apart from extending the validity of the results to different areas, it will also provide a useful means of comparing the reliability of different methods.

THE SURVEYS

In all data from three separate surveys held in the area around the Sunk lightvessel have been analysed. The first survey took place from Saturday 20 May 1972 - Sunday 21 May 1972; the second from Sunday 2 July 1972 - Monday 3 July 1972 and the third from Wednesday 5 July 1972 - Thursday 6 July 1972. A comparison of the three surveys is given in Table 3.4 and shows the duration of each survey, the number of ships whose movements were recorded during the survey, the number of six minute intervals recorded, the weather conditions prevailing and the position of the 'Sir John Cass' with respect to the Sunk light vessel. These positions are marked on Fig. 3.9, which is the sketch map of the survey area and gives an idea of the relation of the survey ship to the buoys and other objects in the area.

The visibility was more or less the same for each of the surveys but the start of the second survey was made at the tail end of a gale. The wind had already moderated considerably by the start and continued to do so throughout the night. However, this plus the fact of it being Sunday

| | SURVEY 1 | SURVEY 2 | SURVEY 3 | ALL SURVEYS |
|---|-------------------------------|---|--------------------------------|-------------|
| Date | 20.5.72 - 21.5.72 | 2.7.72 - 3.7.72 | 5.7.72 - 6.7.72 | - |
| Duration of Survey | 21.00 - 05.06 | 15.51 - 15.45 | 19.24 - 09.33 | - |
| Position of M.V. 'Sir John Cass' with respect to Sunk lightvessel | 2.05 N. Miles West | 1.80 N. Miles West-South-West | 1.50 N. Miles North-North-East | - |
| No. of Ships Recorded | 70 | 137 | 103 | 310 |
| No. of Six Minute Intervals Recorded | 72 | 225 | 132 | 429 |
| Weather Wind (Force) Sea Condition Visibility | 3-4 Slight sea 10 miles | 4-5 later 3-4 Moderate sea 10 miles | 2-3 Slight sea 10 miles | - - - |

Notes (see p.320)

TABLE 3.4 Comparison of the External Conditions of the Three Sunk Surveys

probably accounts for the relatively smaller number of ships whose movements were recorded during this survey. It should be mentioned, while considering the weather, that survey work became rather uncomfortable if the wind force were above about force 5. There is only limited shelter from a south-westerly direction at this point so with the wind from any other direction it is rather exposed and the 'Sir John Cass' is a fairly shallow draught vessel being intended for work on the River Thames. Thus the survey work was best carried out in reasonably quiet conditions.

The number of six-minute intervals recorded refers to the number of times photographs were available to record the position of ships at each end of a six minute gap. In each survey some photographs were lost for a variety of reasons, such as the film breaking in the camera or the time release button failing to work efficiently. Thus the figures for the number of six-minute intervals recorded and the duration of the survey are not reconcilable for each survey. More details on the loss of photographs are given in Appendix III.

The number of ships recorded refers to the number whose tracks were plotted during the surveys and includes in each case the pilot vessel but excludes the 'Sir John Cass'. Table 3.5 gives a break-down of the number of ships per survey by gross registered tonnage for those that were fully identified and by type only for those that could be identified on that basis alone. As was mentioned earlier (p.45), fishing boats and the pilot boat could be identified by their movements on the screen. The relief pilot boat was also easy to distinguish on its journey from Harwich. The ferrys could often be identified by their distinctive shape and colours, e.g. the Sealink ferrys, but they were not usually close enough for the names to be read and as they were frequent users of Harwich, many of the masters had pilot licences so did not require a pilot in addition. Whenever a ferry has been completely identified it is included in the top half of the table and not with those identified by type alone.

The data on gross registered tonnage was obtained from Lloyds Register of Shipping for 1972⁽²⁷⁾ for those ships whose names were known from the pilotage records. The table is given in the same sub-divisions as in the statistical tables published annually by Lloyds⁽²⁸⁾. A comparison between the size distribution observed in the Sunk surveys and

| NUMBER OF SHIPS FULLY IDENTIFIED | | | | |
|---|-------------|-------------|-------------|----------------|
| Size of Ship Gross Registered Tonnage | Survey 1 | Survey 2 | Survey 3 | All Surveys |
| 100 - 499 | 6 | 15 | 9 | 30 |
| 500 - 999 | 1 | 2 | 3 | 6 |
| 1000 - 1999 | 0 | 3 | 6 | 9 |
| 2000 - 3999 | 1 | 6 | 6 | 13 |
| 4000 - 5999 | 0 | 3 | 2 | 5 |
| 6000 - 6999 | 3 | 1 | 1 | 5 |
| 7000 - 7999 | 0 | 0 | 1 | 1 |
| 8000 - 9999 | 0 | 2 | 2 | 4 |
| 10000 and over | 4 | 6 | 5 | 15 |
| Total number of Ships Fully Identified | 15 | 38 | 35 | 88 |
| NUMBER OF SHIPS IDENTIFIED BY TYPE ONLY | | | | |
| Type of Ship | Survey 1 | Survey 2 | Survey 3 | All Surveys |
| Ferry | 2 | 4 | 6 | 12 |
| Fishing Boat | 8 | 5 | 3 | 16 |
| Yacht | 1 | 4 | 0 | 5 |
| Pilot Boat | 1 | 1 | 1 | 3 |
| Relief Pilot Boat | 1 | 2 | 0 | 3 |
| Total Number of Ships Identified by Type Only | 13 | 16 | 10 | 39 |
| Total Number of Ships Identified Fully or by Type | 28 | 54 | 45 | 127 |
| Total Number of Ships | 70 | 137 | 103 | 310 |

Notes (see p.320)

TABLE 3.5 Number of Ships Fully Identified by Size (Gross Registered Tonnage) and Identified by Type Only by Survey. Sunk Surveys.

that known worldwide is given in Appendix III. It is shown that there is a larger percentage of bigger ships in the Sunk surveys than world-wide.

Fujii and Tanaka⁽²³⁾ consider the length of a vessel to be connected to the size of the domain so in addition to the distribution by gross tonnage for the ships identified, a distribution by length was also prepared. For each ship, its length between perpendiculars was found from Lloyds Register of Shipping and the resulting distribution is given in Table .

The two longest ships were a 37000 ton Norwegian bulk carrier of length 772 ft. and a 41000 ton Norwegian tanker of length 760 ft. while the smallest ship both in length and tonnage was a 210 ton West German cargo ship of length 138 ft.

The identification rate for all the surveys combined was 28%, with individual rates of 21% for survey 1, 28% for survey 2 and 34% for survey 3. Performing a χ^2 test of homogeneity a value of 3.28 is obtained which when compared with the 5% value on 2 degrees of freedom of 5.99 shows this is a non-significant result. Hence it may be assumed that these individual rates are not significantly different from each other.

If the figures for ships identified by type alone are included, the identification rate goes up to 41% for all surveys, with 40% for survey 1, 39% for survey 2 and 44% for survey 3. There is again no significant difference between the rates per survey.

OTHER SOURCES OF DATA

Apart from the sets of data described in this chapter, other data have been collected during the project but as they have not been fully analysed to date for inclusion in the later chapters of this thesis, they will only be briefly mentioned here.

Further Sunk Surveys

Two further Sunk surveys of the type described above were carried out in 1973, one of nineteen and a half hours duration on 31 March - 1 April, and the second of thirty hours duration on 23 - 24 June. One change in technique was to use a wide angle 35 mm lens which increased the coverage of the screen from 20 miles x 14 miles to 24 miles x 18 miles. An example

| Length of Ship B.P. (Between Perpendiculars) feet | Survey 1 | Survey 2 | Survey 3 | All Surveys |
|---|-------------|-------------|-------------|----------------|
| 100 but under 200 | 5 | 13 | 7 | 25 |
| 200 " " 300 | 2 | 6 | 12 | 20 |
| 300 " " 400 | 1 | 9 | 9 | 19 |
| 400 " " 500 | 5 | 4 | 1 | 10 |
| 500 " " 600 | 0 | 5 | 6 | 11 |
| 600 " " 700 | 1 | 0 | 0 | 1 |
| 700 " " 800 | 1 | 1 | 0 | 2 |
| Total Number of Ships Fully Identified | 15 | 38 | 35 | 88 |
| Total Number of Ships | 70 | 137 | 103 | 310 |

Notes (see p.321)

TABLE 3.6 Number of Ships Fully Identified by Length Between Perpendiculars (in feet) and by Survey. Sunk Surveys

from this survey is given in Appendix III where it can be seen that definition is still very good.

A third Sunk survey was conducted from 13 October - 14 October 1972 on board the R.R.S. Discovery by kind invitation of the N.E.R.C. She was engaged in oceanographic survey work in the area around the sunk lightvessel for that weekend; however as the ship was not stationary during the photographic survey, the frames were very much more difficult to analyse. It was therefore decided to leave analysis of this and the other two surveys until after the methodology for determining a domain boundary had been established in this thesis.

Dover Strait Survey Data

The survey, conducted under the auspices of the National Physical Laboratory, of traffic in the Dover Strait has already been mentioned in terms of the survey method used (p. 48). Film from that survey was made available for this project and the tracks of ship movements were plotted covering a period of several hours. Fig.3.12 shows the movements recorded in a typical half-hour during the period, and in particular the separation zones are very clear. Unfortunately, since the film was made with a radar range of 24 miles, the definition obtained was not very good. It was also not possible to increase the projected size of the film since a special piece of equipment had to be used to run the film frame by frame. Fig. 3.12 is reproduced in the original scale on which tracings were made. It was again felt that it was better to devote time to the establishment of methodology, but as was mentioned earlier, it is hoped to analyse some of this data later. It is understood that film is now being produced on a 12 mile range scale so this should provide adequate definition and will be a considerable help.

SUMMARY

In this chapter the methods of obtaining the primary data for the survey have been described. The two principal sources for the data were firstly the records of the performance of Merchant Navy officers in exercises on a marine radar simulator and secondly, traffic surveys conducted in an area of the North Sea centred on the Sunk lightvessel. Descriptions of the primary data were given and for the traffic surveys the methodology was compared to that used in other surveys. However, a detailed discussion of the suitability of the two sources of data will be given in the next chapter after the methods of production of the secondary data required for the analyses have been considered.

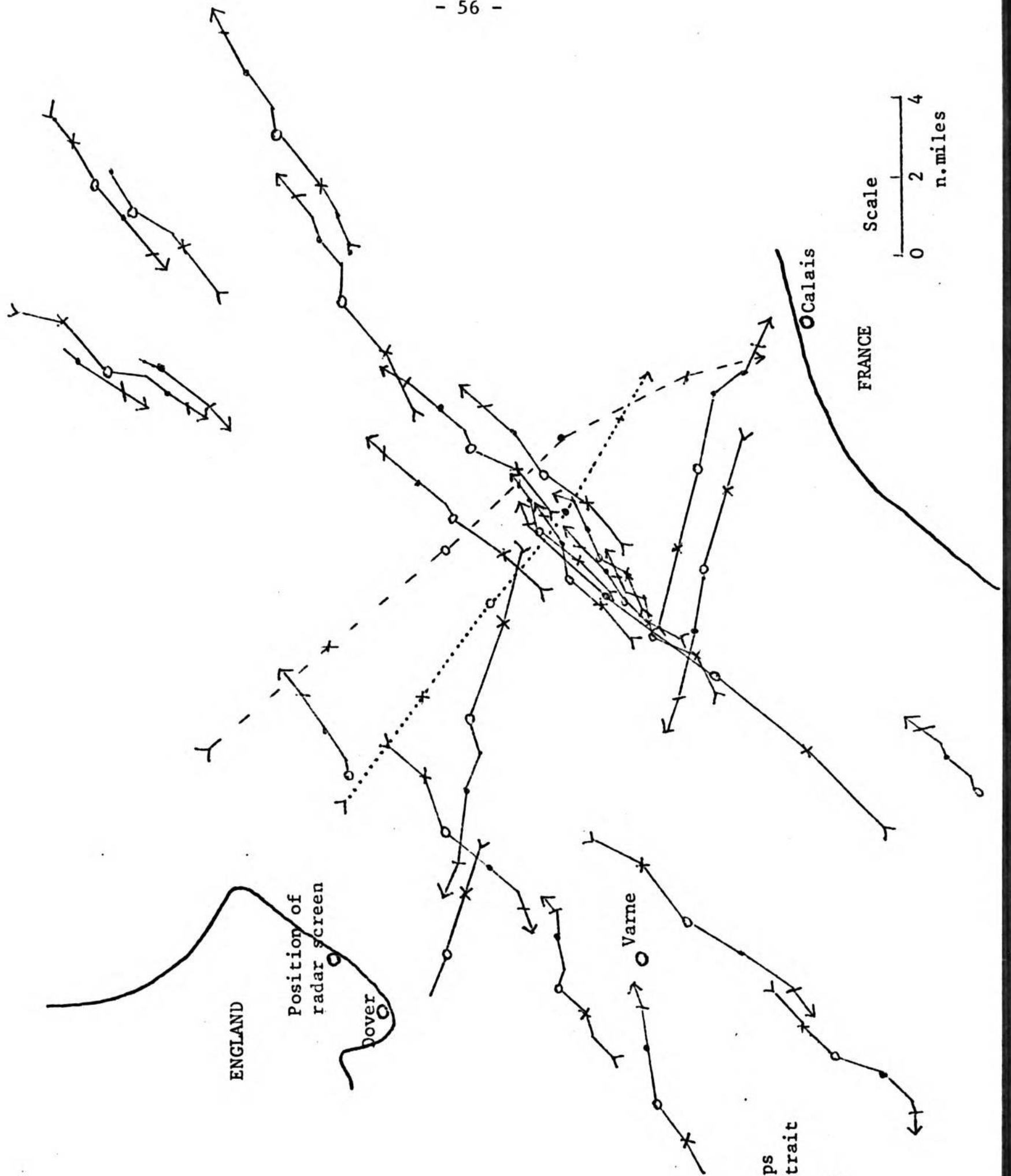

KEY

- > 1533
- x 1539
- o 1545
- 1551
- / 1557
- 1600

- - - Hovercraft

..... Ferry

— Other ships

FIG. 3.12 A Plot of Ships
 Tracks Through the Dover Strait
 on 15.10.72, 15.33-16.00.
 From the National Physical
 Laboratory Survey Film

CHAPTER 4

The Processing of the Data

INTRODUCTION

The previous chapter was concerned with the primary data obtained whereas this chapter deals with the secondary data needed as inputs for the subsequent analyses. Since it is required to perform the same type of analysis on each of the two sets of data, simulator and Sunk survey, the required form of the secondary data will be the same in each instance. The first part of the chapter therefore contains a description of this common format needed in both cases. The two subsequent sections deal with the particular methods used in each instance to reach the desired form. The final part of the chapter contains a discussion of the suitability of each of the two sets of data produced for the analyses to be carried out.

THE REQUIRED FORM FOR THE SECONDARY DATA
FROM THE SIMULATOR AND SUNK SURVEY PRIMARY DATA

To investigate the size and shape of a ship domain from the raw data on ship movements obtained by the methods described in the previous chapter, the behaviour of ships relative to each other must be examined.

For any one ship, the distance and relative bearing of all other ships in its vicinity at any given time can be ascertained. Thus the distribution of the other ships around the central ship at that point in time can be plotted. If a second point in time is considered and the process repeated, then the superimposing of the second distribution on the first will provide a better picture of the typical distribution of other ships around the central ship at any point in time. If the process is repeated for many points in time the picture should become even better defined. In addition to considering one ship at several points in time, it is also possible to consider all the ships in a given area as the central ship in turn and superimpose the different distributions obtained. This way a picture can be built up representative of a variety of ships and times. Fig.4.1 gives a typical distribution obtained using some data from one of the traffic surveys. The line of reference for each central ship at any point in time is the direction of the ship's head then and the positions of the other ships are measured relative to that. The

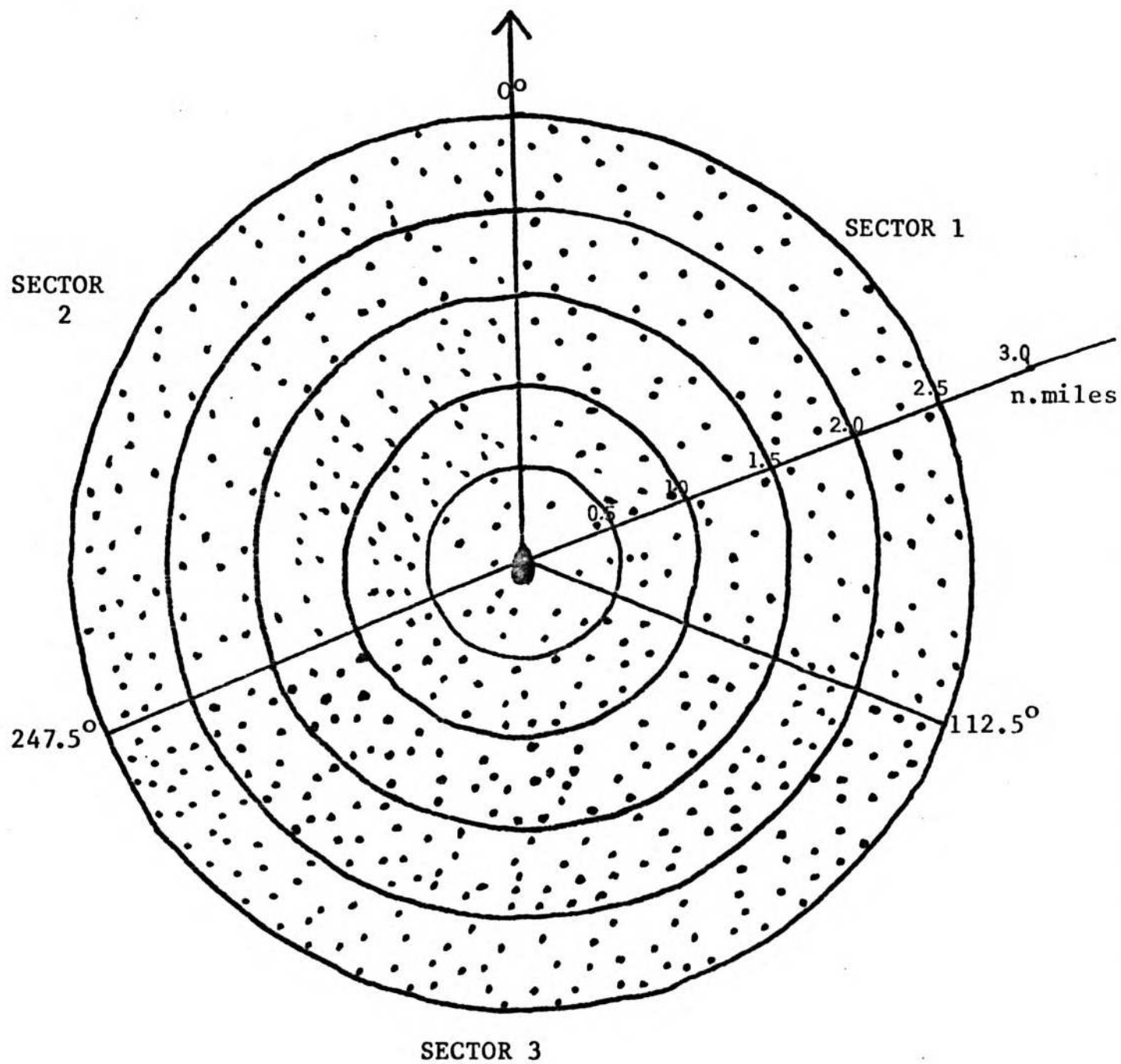

Scale: 1" represents 1 nautical mile

FIG. 4.1 Distribution of Other Ships Around the Central Ship (Sunk Survey 1)

relative bearing of another ship is the angle θ , measured clockwise which the line joining the two ships makes with the reference line. The distance of another ship from the central ship, x , is the radial distance between the two.

It can be seen in Fig.4.1 that there appears to be an area around the central ship which is relatively free from other ships and the next chapter will examine how to define the dimensions of this area. In the present chapter the methods used to process the data into a suitable form for analysis will be discussed.

In the section on ship domain geometry in a previous chapter (see page 17), it was suggested that the radius defining the domain boundary might be different in each of three sectors of the area around the central sector because of the international collision regulations. The three sectors can be defined in terms of θ , the bearing of the 'other' ship from the central ship as:-

- Sector 1: $0^{\circ} \leq \theta < 112.5^{\circ}$ - starboard sector
- Sector 2: $247.5^{\circ} \leq \theta < 360^{\circ}$ - port sector
- Sector 3: $112.5^{\circ} \leq \theta < 247.5^{\circ}$ - astern sector

The three sectors are shown in Fig. 4.1. It should be mentioned that to be strictly in accordance with the collision regulations, the actual value of 112.5 should be included in Sector 3 rather than Sector 1. However, as the number of points that actually fell on a boundary line were very small indeed, this will not affect the results in any way.

The other parameter defining the relative position of the 'other' ship from the central ship is the distance between the two x . It was decided to consider the distances in range-increments of $\frac{1}{10}$ nautical mile since this was the degree of accuracy justifiable with this data.

The secondary data needed for any analyses to find the radius of the domain boundary comprise the distribution of numbers of 'other' ships with respect to the distance from the central ship. As the sector difference is expected to be important, the distributions are produced separately for each sector.

Fig. 4.2 gives a larger scale version of the 'dartboard' grid which was shown superimposed on the distribution of ships around the

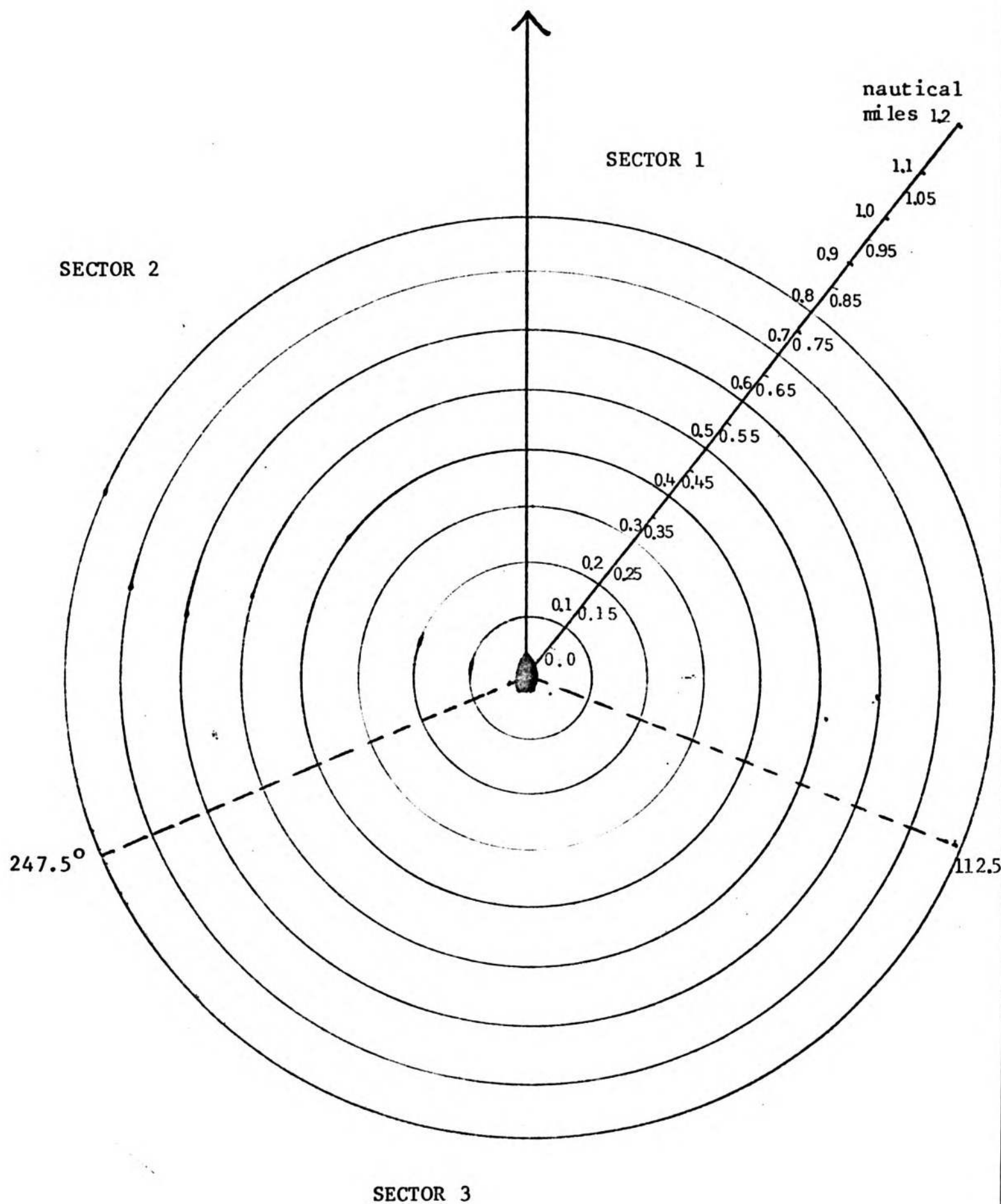

Scale: 1 cm represents .1 nautical miles.

FIG. 4.2 Diagram to Represent the Areas of Sea Around the Central Ship Considered in the Analyses

central ship in Fig. 4.1. It is thus evident that the distributions required can be formed by counting the number of points falling inside each of the appropriate divisions on the 'dartboard'.

Independent Variables

For any one ship at a given point in time, the distances and relative bearings of all other ships in the vicinity must be known for the basic analyses as just discussed. However, as the dependence of the ship domain on various independent variables is also to be investigated, it must be possible to associate the relevant value with an individual ship at a point in time. In particular, since relative velocities are thought to have some connection with domain size this must be calculated for the central ship with respect to each of the other ships in the vicinity for a given instant. Other variables such as size of ship, experience of navigating officer, etc., will obviously stay constant for one ship but it is still necessary to associate a particular distance and relative bearing with a value for size of ship, etc.

THE COMPUTER

Since the amount of data available was obviously considerable with each ship related to every other one in the area at a series of points in time, it was evident that a computer should be used for the analyses. Even to have produced the distributions of numbers of 'other' ships with respect to distance from the central ship by sector would have been a lengthy procedure by hand, and since relative velocities had to be calculated in addition, the task was obviously impracticable without a computer.

The City of London Polytechnic Computer Centre offered, at the time that the analysis was carried out, a choice of computing facilities. Some of this work was done using the Hewlett-Packard 2000 time-sharing services but the storage facilities were not really large enough. The majority of work was therefore done on an ICL 1905 machine, and the programs were written in 1900 Fortran.

The next sections of this chapter will deal with the preparation of the computer records and the basic programs used. However, as the records were prepared in a different way for the two sets of primary data, simulator and Sunk survey, they must again be considered separately.

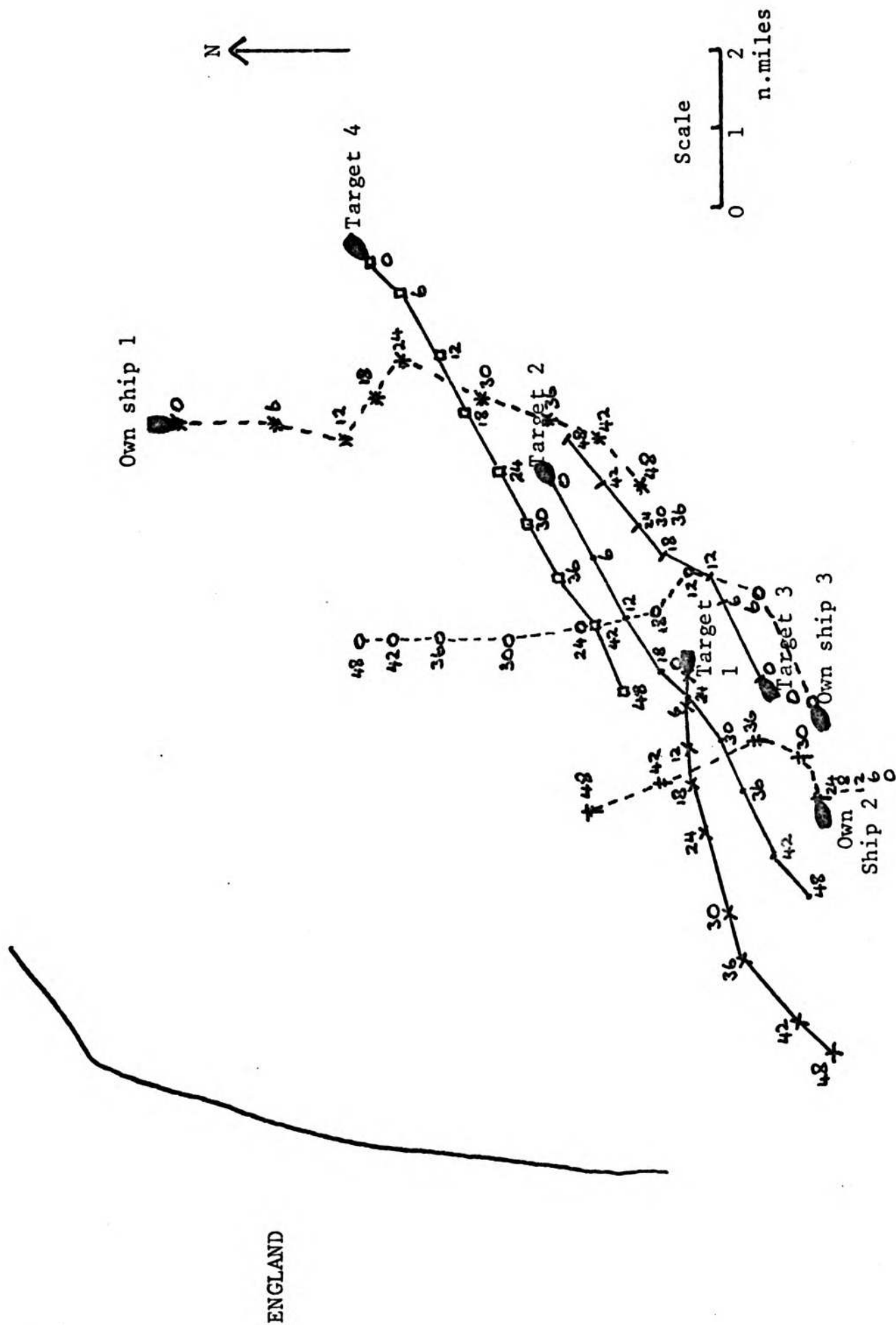

FIG. 4.3 Dover Strait: Exercise 19: One Development of the Situation

SIMULATOR DATA: COMPUTER RECORDS

The records were prepared by exercise, so that one complete set contained all the information on an exercise.

PRELIMINARY WORK

A certain amount of work was initially done by hand on the simulator data. Using the tracing of an exercise, each own ship was considered in turn and the distance and relative bearing of the other own ships and the target ships were measured. Six minute intervals were chosen at which to make the measurements, as the pattern of relative manoeuvres is important and to have taken fewer measurements might not show this up. However, on the other hand, the measurements should not be too close together otherwise too much emphasis might be given to individual extreme encounters. The choice of time interval is considered again on p.78 when a critical discussion of the data is given.

With reference to Fig. 4.3, which shows the plots for one development of Exercise 19, an exercise in the Dover Strait, 9 time points were taken since the exercise ran for 48 minutes. The distance between two ships could be measured directly, but to measure the relative bearing of one ship from the central ship, the heading of the central ship also had to be ascertained. This was required additionally for the calculation of relative velocity. Speeds were also needed for this so for all the ships in the situation this had to be estimated at each of the time points. This was done in conjunction with the notes which the students kept as alterations of speed and course were asked for. If there were no change of speed and course, apparent or stated, the speed could be estimated from the distance travelled over as long a time interval as possible around the point in question. If there were a change then the speed at a given point in time was estimated by the distance travelled in the next 6 minute interval x 10. An example of the notes kept by the navigator in own ship 3 in the exercise depicted in Fig. 4.3 is given in Appendix IV.

FORMAT OF THE RECORDS

There were four types of cards carrying the required information for a single exercise. The details on each type were as follows:

Set 1: Exercise Parameters

Viz:- Course number
Exercise number
Number of time points recorded
Number of own ships
Number of target ships
Number of ship encounters to be considered

Set 2: Speeds and Courses of the Ships

These were given for each of the own ships and target ships. Both the speeds and courses were recorded to the nearest integer as it was felt that no further accuracy was justified.

Set 3: Details on other Independent Variables

Viz:- experience of each navigating officer
size of ship in gross registered tonnage
maximum speed of ship.

These details were given for each of the own ships.

Set 4: Distances and Relative Bearings

Each own ship was taken as central ship in turn and the distances and relative bearings of all other ships from it recorded. Distances were given to the nearest tenth of a mile and relative bearings to the nearest degree, since this again was the highest degree of accuracy considered justifiable.

A fuller description of the format of the records is given in Appendix IV, including details on the ordering of the encounters within each exercise. Also given is a print out from the exercise shown in Fig. 4.3

REQUIREMENTS FOR THE BASIC PROGRAM

From the required form for the secondary data given at the start of the chapter and the format of the input records just discussed, it is clear that the requirement for the basic program, ignoring any of the independent variables, is to sort the distances and relative bearings into the appropriate distance cell by sector. This must be done for each exercise, and an aggregate for each distance cell for each sector printed at the end. A copy of the program used to do this is given in Appendix VIII. It was decided to choose an arbitrary cut off for the distributions at 5 n.miles because at that distance from a central ship the effect of a domain is most unlikely to be felt. From the results

obtained in the following chapters this would seem to be a justifiable decision. Figs. 4.4, 4.5 and 4.6 show the distributions by sector for all exercises combined.

MODIFICATIONS TO THE BASIC PROGRAM

Each exercise has necessarily a fixed set of starting positions set up by the instructor as illustrated in the previous chapter. Thus it can hardly be considered that at the start of the exercise any particular group of officers is in a series of positions chosen by themselves. It was therefore decided that the analysis of relative bearings and distances should only start at a point where an individual officer had had time to assess the situation and manoeuvre accordingly. The omission of the first two recorded points at 0 and 6 minutes after the start respectively, meant that the first set of positions analysed were those 12 minutes from the start of the exercise. This was felt to give a reasonable amount of time for the immediate initial situations to be sorted out. Figs. 4.4, 4.5 and 4.6 show the distributions with the first two time points omitted superimposed on the basic distributions and the modified program used to produce this is in Appendix VIII.

This modification had most effect on the later exercises since in the early open ocean ones the starting points were in fact usually more than five miles apart. It should also be noted that there was a slight variation between exercises of the same number, which accounts for the spread in the values obtained in the first two time points. From the three pairs of graphs it would appear that the shapes of the curves have not changed appreciably with this modification but since it is based on an important practical consideration it was decided to use it throughout the analyses

ANALYSES BY INDEPENDENT VARIABLES

A full description of the analyses produced taking into account the various independent variables will be given in Chapter 6. At this point it is worth describing briefly the approach used, however. The cards containing the information on speeds and courses, the size and type of ships and experience of the navigators was read in once per exercise. It was then necessary to associate appropriate values to each encounter between two ships and, for the information on speed and course, to have these associated with the correct time point. For any encounter with ship A as central ship and ship B as the other ship it should be possible

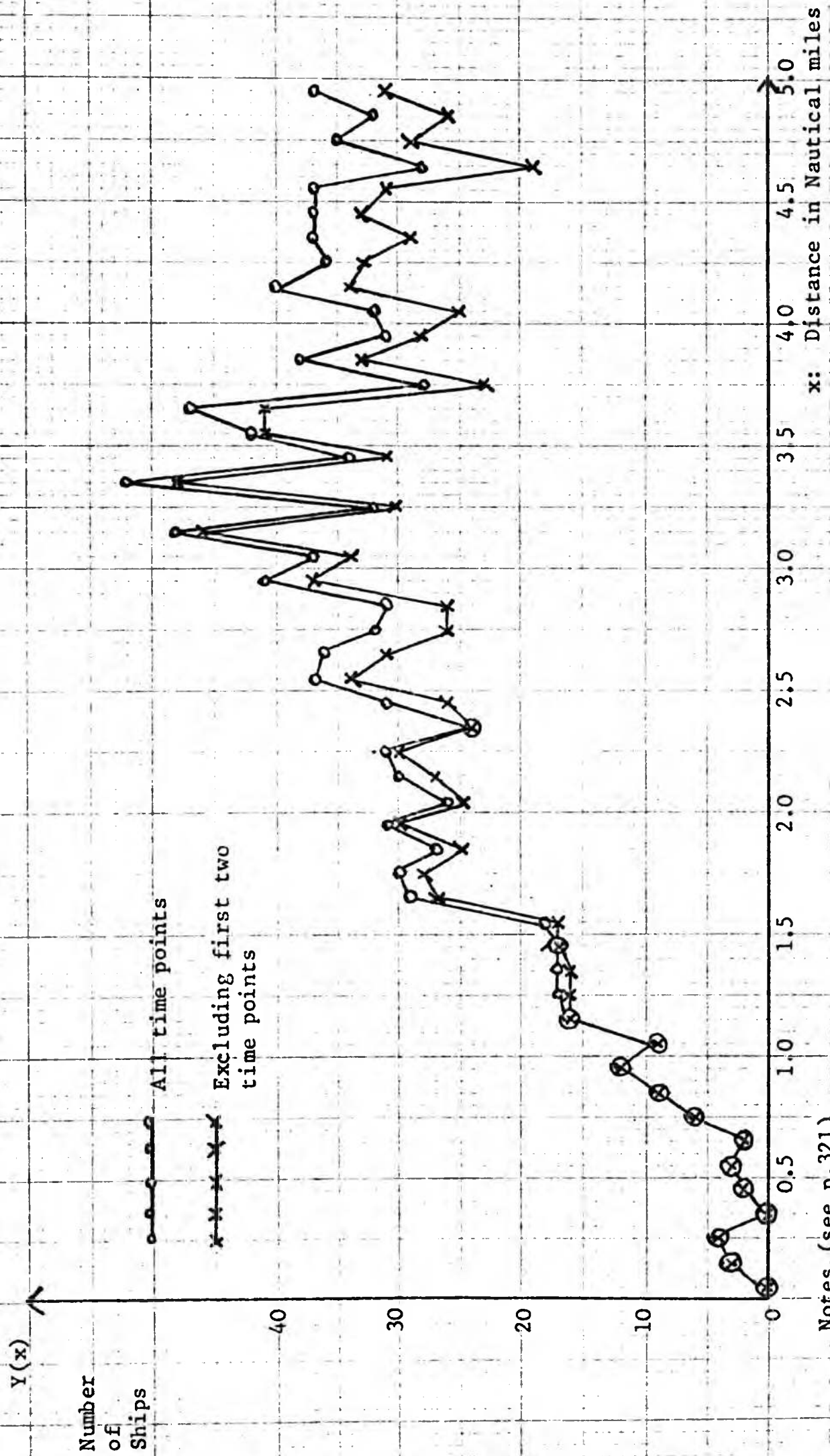

Notes. (see p.321)

FIG. 4.4 Simulator Data: All Exercises: Sector 1
The Distribution of Ships Around a Central Ship: actual results

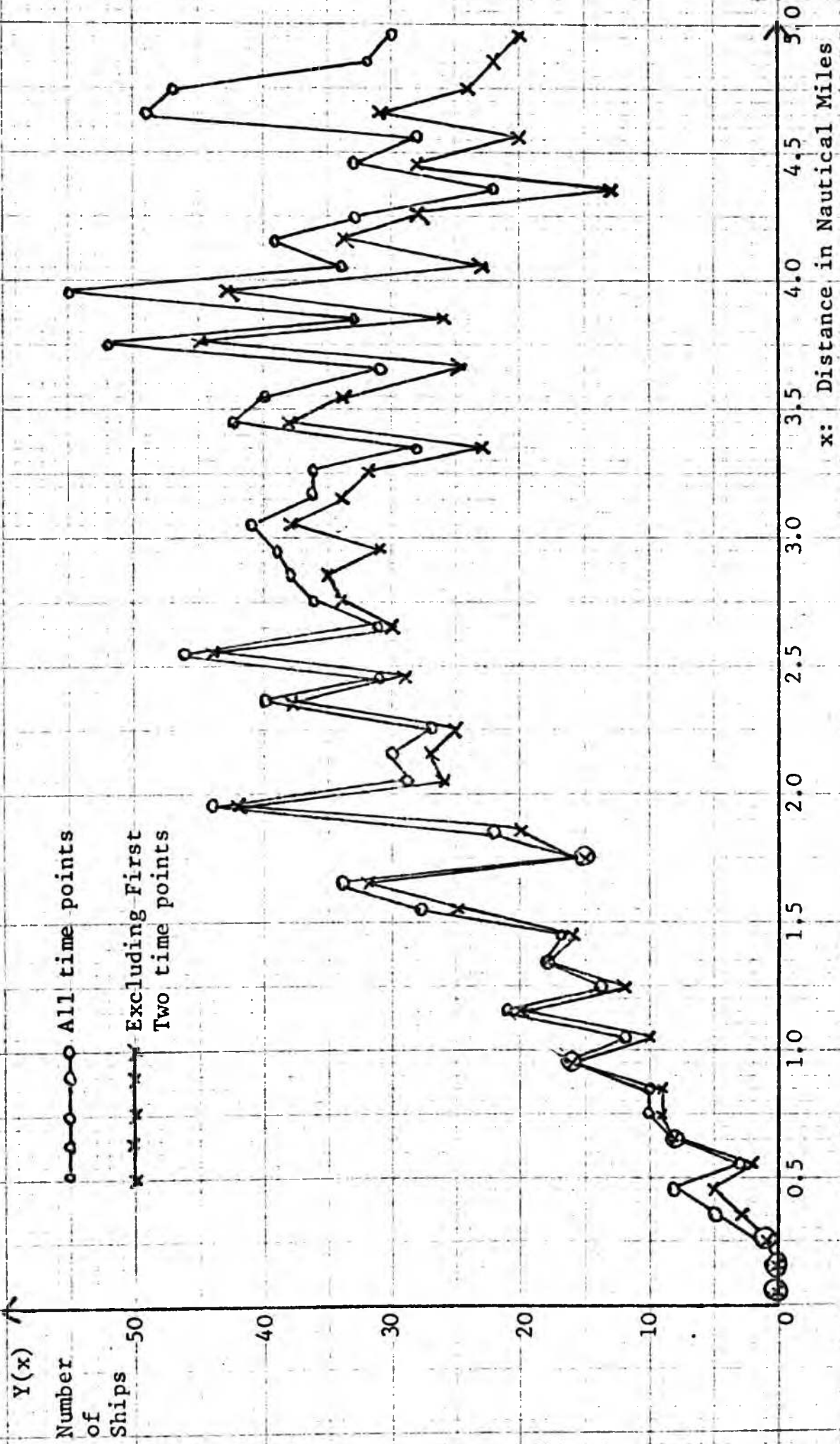

Notes (see p.321)

FIG. 4.5 Simulator Data: All Exercises: Sector 2: The Distribution of Ships Around a Central Ship: Actual results

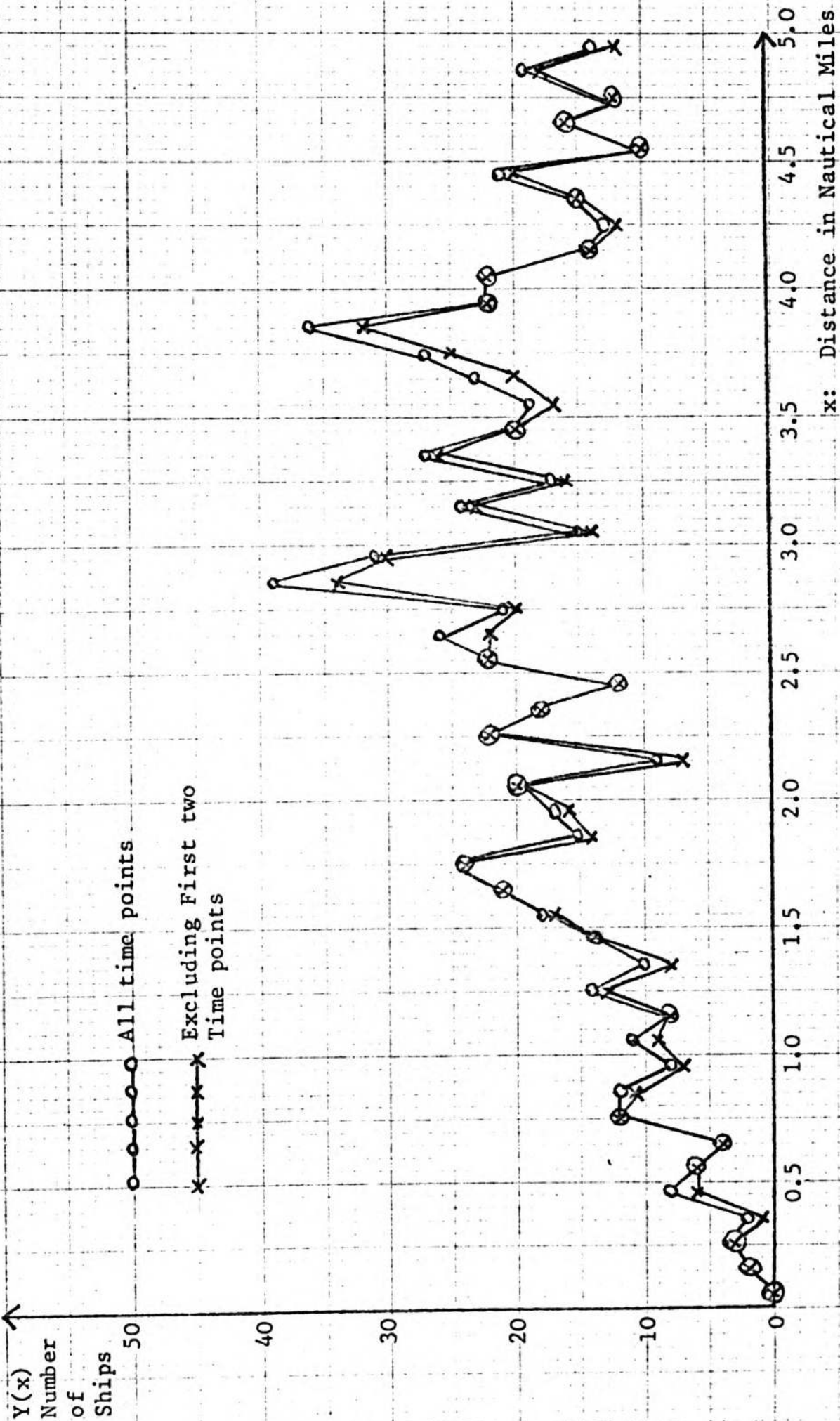

Notes (see p.321).

FIG. 4.6 Simulator Data: All Exercises: Sector 3:
The Distribution of Ships Around a Central Ship: Actual Results

to know at any point in time, the distance between the two ships, the relative bearing of B from A, the relative velocity of B with respect to A, the experience of the navigator of ship A and the type of ship A. The programs to do this are given in Appendix VIII

CHECKING PROCEDURES

Some independent checking procedures were devised both for the programs and for the data. Full details of these are given in Appendix IV.

SUNK DATA: COMPUTER RECORDS

PRELIMINARY WORK

The situation for this data was different from that for the simulator data because in that case there was no direct connection between the ship movements in one exercise and in another. Thus the exercise provided a suitable unit for preparation of data. However, for the Sunk data there was no such convenient unit, especially as ships in one hour would appear also in the following hour. It was therefore decided to register the position of a ship at any point in time in Cartesian coordinates. The choice of origin was fairly straightforward as it was decided to take the position of the 'Sir John Cass', and the direction of the positive y axis was along the North line from there. A transparent grid was placed over the plots and hence the appropriate positions could be read off. Each ship observed in the surveys was originally given a unique five digit identification number. The first digit was either 1, 2 or 3 depending on the survey and the remaining four gave the number of the ship in chronological order from the start of the survey. This numbering was used for all ships apart from fishing vessels and the pilot vessel to make these latter types of ship distinguishable at a glance. For them a three digit number was used, with the first again denoting the number of the survey. The last two referred to the chronological appearance of the ships with 00 being used for the pilot vessel. The numbering system was then extended to cover the buoys as well and as there were only ten easily distinguishable, a two digit number could be used, the first of these referring to the survey number.

FORMAT OF THE RECORDS

It was decided to treat each ship at each point in time as a separate record. The information on each record, which was in fact only one card long was as follows:-

Ship Number
X Coordinate of Position at time T
Y Coordinate of Position at time T
X Coordinate of Projected Position at time T + 1
Y Coordinate of Projected Position at time T + 1
Time T
Position in Area
Length of ship
Gross tonnage of ship

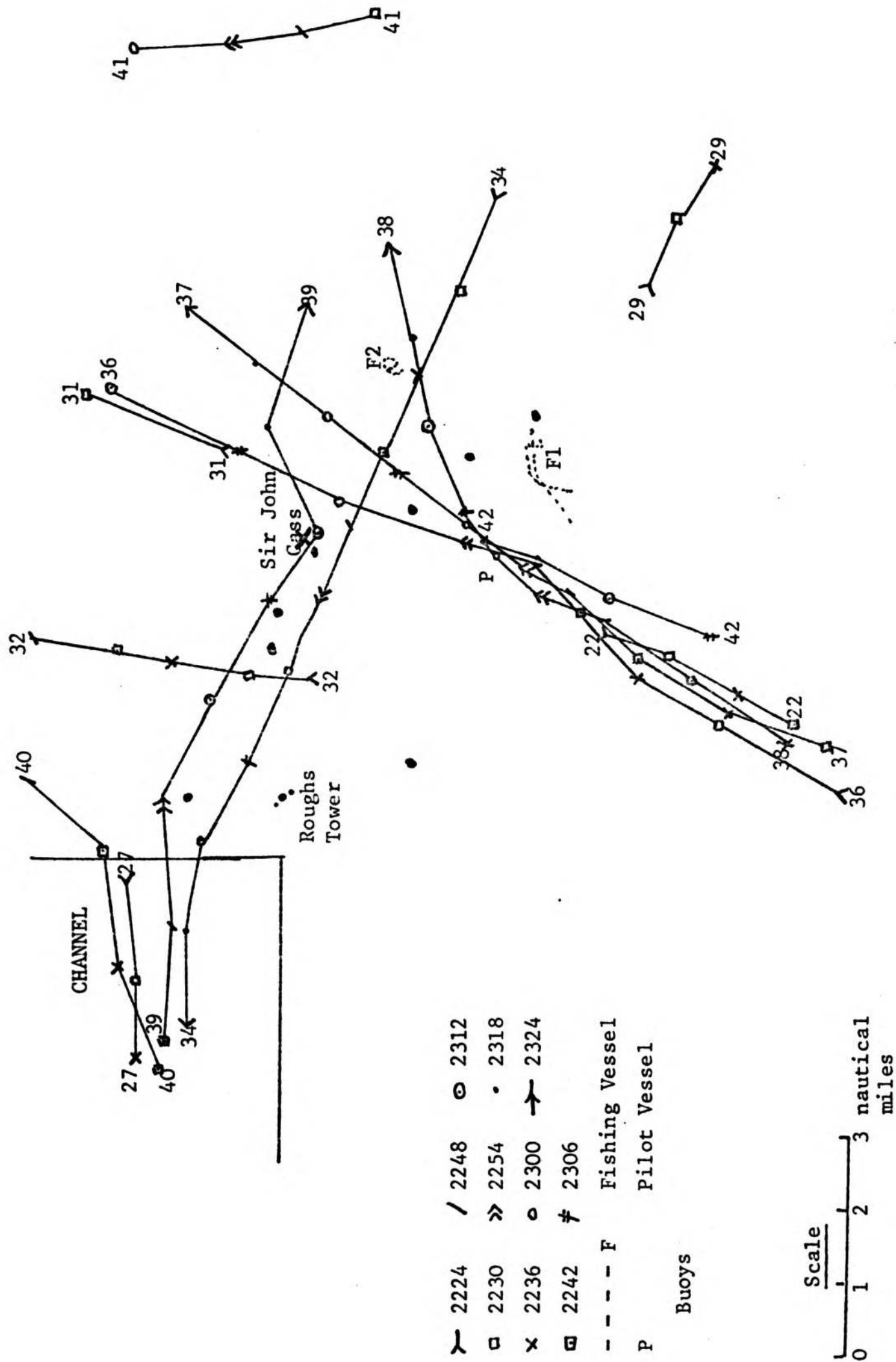

FIG. 4.7 Tracks of Ships Passing Through the Survey Area: Sunk Survey 3, 5.7.72 22.24 - 23.24

The time $T + 1$ referred to above was the time six minutes after the time at which the position was recorded. The coordinates measuring the position were recorded to the nearest tenth of a mile since in this case too this was felt to be the highest degree of accuracy really justified.

The variable, position in the area, was used to distinguish when ships were in different parts of the area where the navigating conditions might be altered. Fig. 4.7 shows another hour's traces with the ships' numbers superimposed. In the left-hand corner an area has been divided off to denote the channel approaches to Harwich and Felixstowe. Ships were given a special position number if they were within this area. The position number could also be changed to identify ships near the pilot boat. Additionally, it could be used to indicate whether there was actually a pilot on board or not. Ships at anchor were given a special position number but otherwise the ships were given a position number of 0 to indicate a general position in the area.

Fuller details on the format of the records including the reasons for the choice of this particular method are given in Appendix IV. Also given is information on the particular codes used for each of the variables which indicates the amount of detail available.

REQUIREMENTS FOR THE BASIC PROGRAM

Although the data format was simpler in this case, there was more work to be done in the basic program. The program had to take each ship in turn, calculate the distance and relative bearing of all the other ships in the area at the same point in time and then allocate the values obtained into the appropriate cells on the dartboard grid. Finally the aggregate number of values in each distance cell had to be printed by sector. To economise on time and storage, the cards were sorted by hour and each hour was read in successively. Thus all cards referring to any time beginning 22 say, on one survey would be read in together. This was also useful when checking programs and cards as each hour could be printed out separately. The resulting distributions obtained in Survey 2 are shown graphically in Figs. 4.8, 4.9 and 4.10. The figures for all three sectors have again been presented in the main text for completeness sake. The question of differences between them will be developed fully in the subsequent chapters.

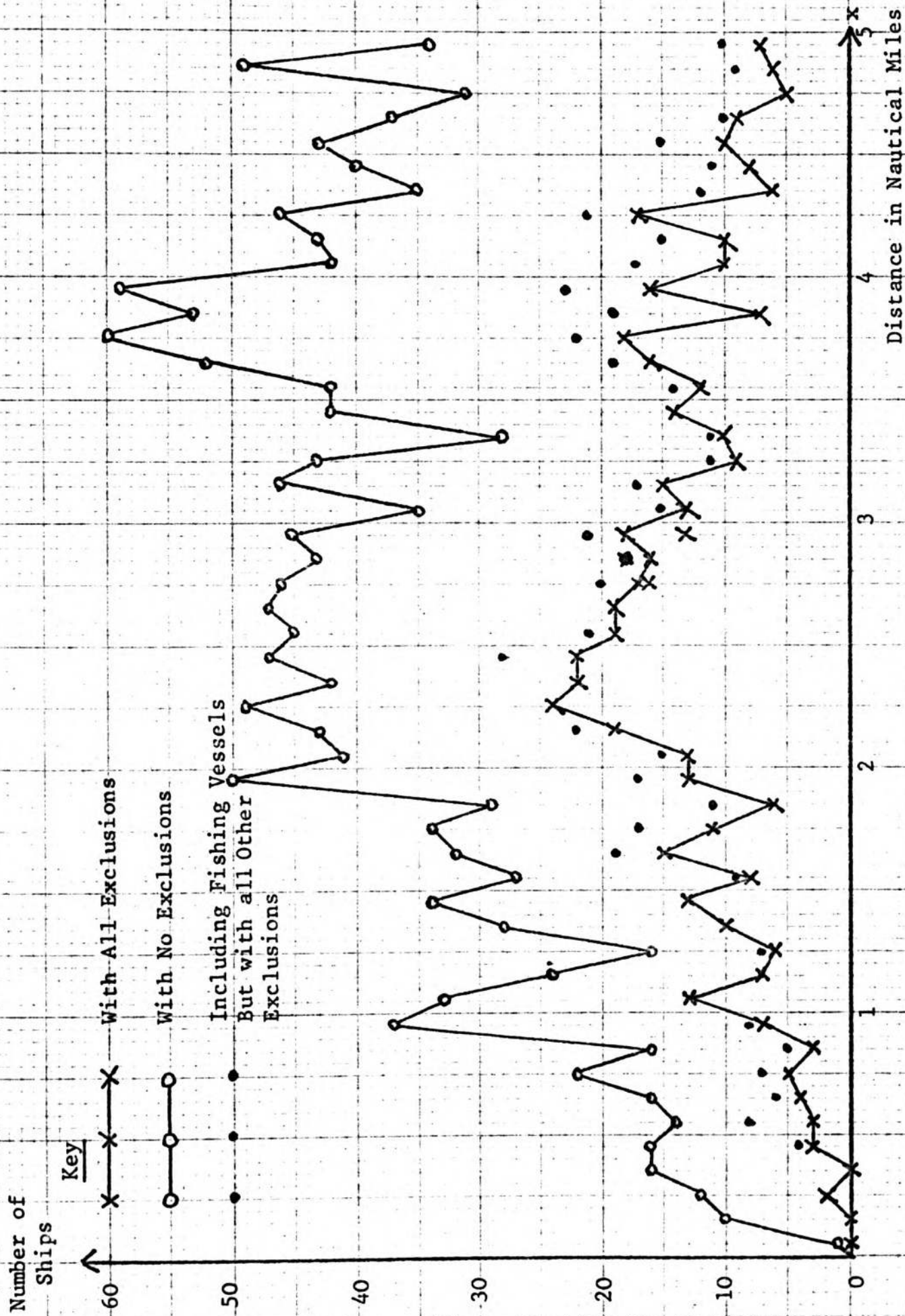

NOTES (see p.321)

FIG. 4.8 Sunk Survey Data: Sector 1: Survey 2
Number of Ships Under Different Circumstances

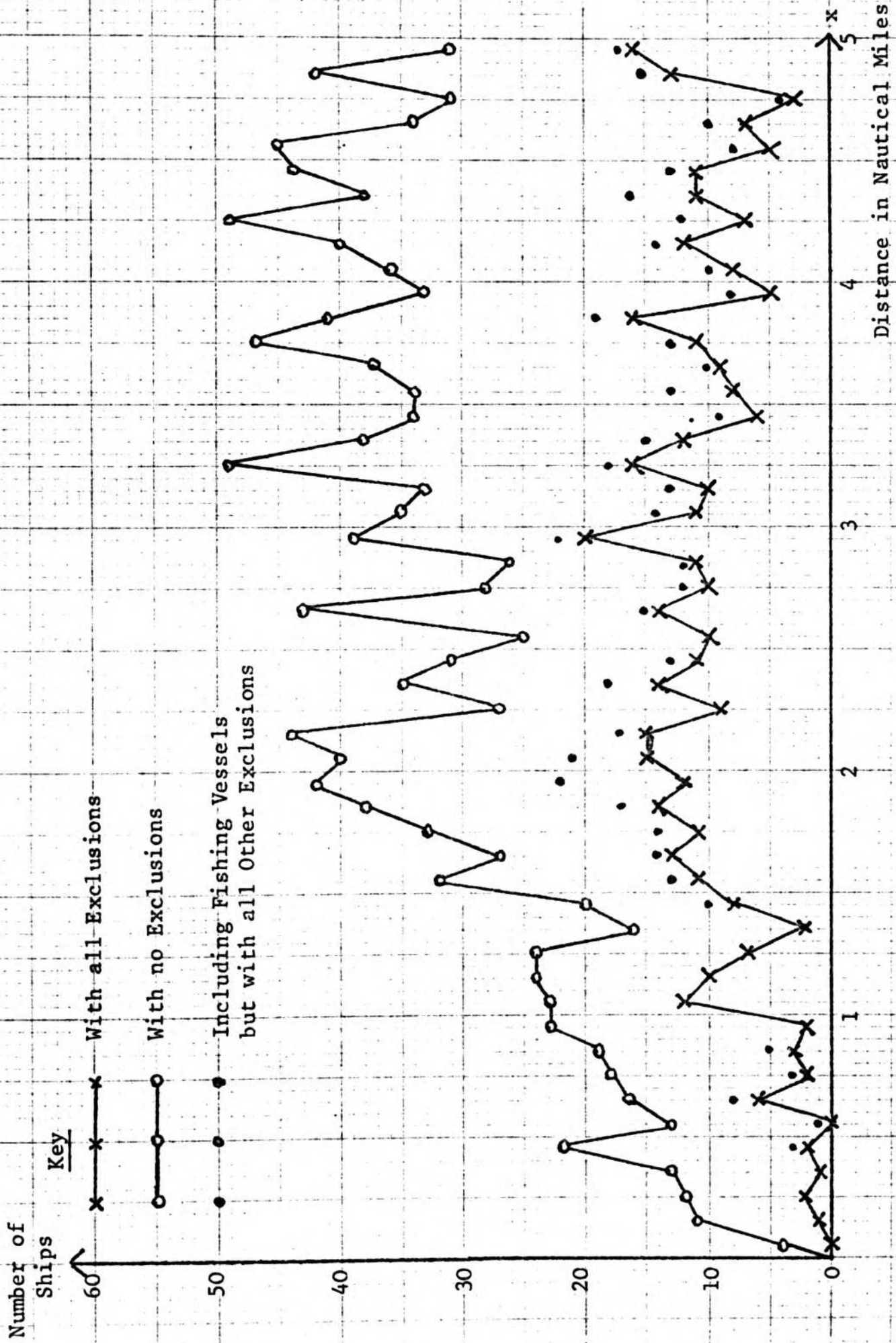

Notes (see p.321)

FIG. 4.9 Sunk Survey Data: Sector 2: Survey 2
Number of Ships under Different Circumstances

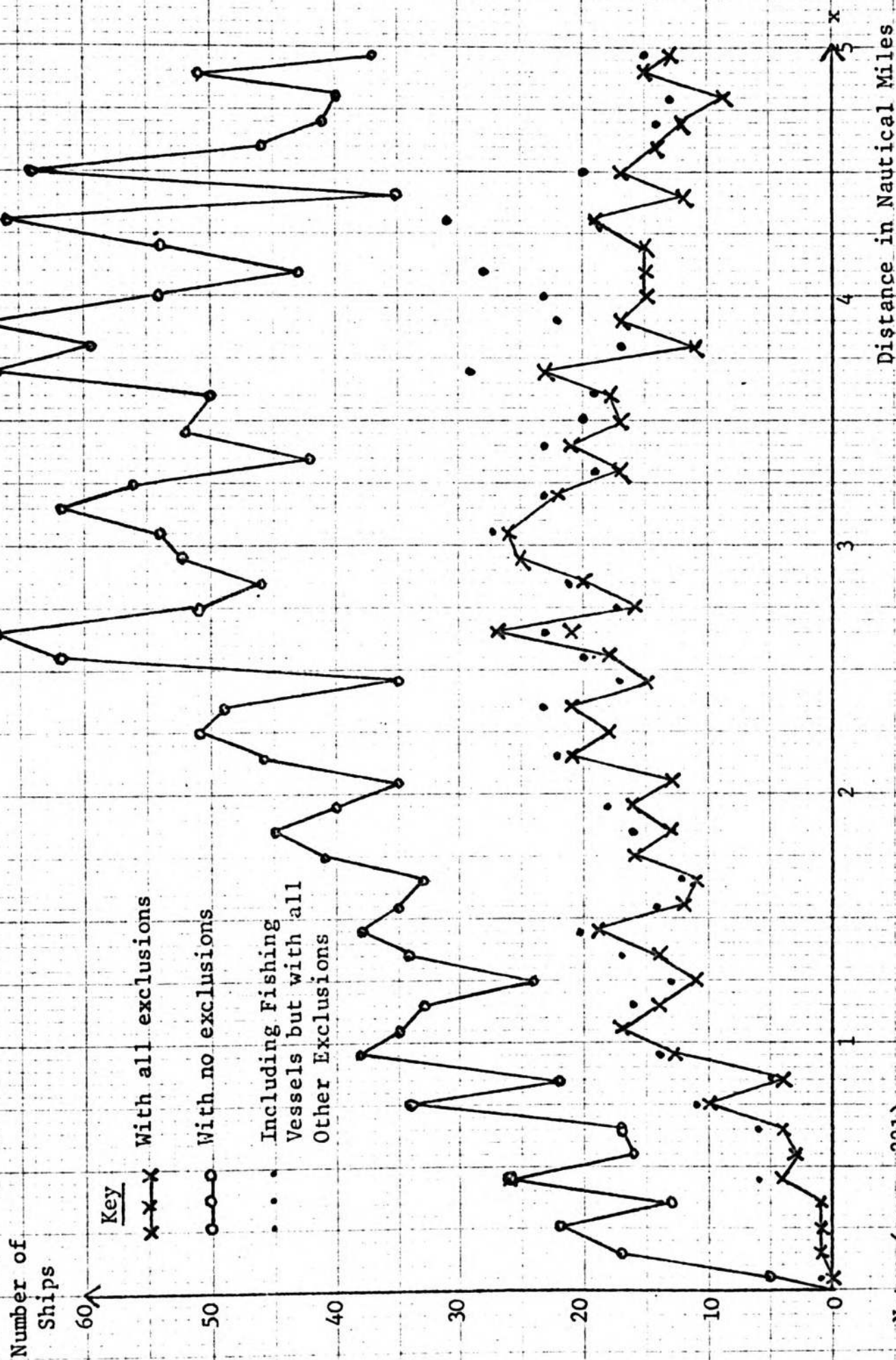

Notes (see p.321)

FIG. 4.10 Sunk Survey Data: Sector 3: Survey 2
Number of Ships Under Different Circumstances

MODIFICATIONS TO THE BASIC PROGRAM

Owing to the varying nature of the area, it was decided that it was not really advisable to include all ships in the main basic results. It was therefore decided to exclude as central ship all ships which were not in the main part of the area or which were near the pilot vessel or were at anchor, i.e. all ships which had a position number other than 0. In addition, it was decided to exclude as central ship the pilot vessel and fishing vessels since they are navigating under different conditions.

With any radar display there is the problem of loss of targets as one goes away from the centre of the screen. This point will be considered later (p.82) but the effect is that for those ships towards the edges of the display, one is probably not picking up all the ships near it and of course there are the ships outside the coverage of the radar. An extra exclusion was therefore made so that only ships within 3 miles of the centre of the screen should be considered as central ship. A copy of the basic program including these modifications is given in Appendix VIII, and the modified results for one of the surveys are shown in Figs. 4.8, 4.9 and 4.10. The large numbers of very close distances in all three sectors are caused by the ships in the vicinity of the pilot boat. The approach of a ship to the pilot boat while a pilot is being transferred is obviously very close and when there are no exclusions, this will obviously appear twice, once when the pilot boat is central ship and once when the other ship is. Additionally, it was quite common to have more than one ship in the vicinity of the pilot boat at any one time which also produced some close approaches, as they waited their turn for the pilot. Also shown on the graphs are the distributions by sector when ships in the Channel and ships in the pilot vicinity are excluded as central ship but fishing vessels are still included. This does not affect the basic pattern as extensively as if no modifications were made but it is still considered better to exclude them as well, as their manoeuvring patterns are so different from ordinary ships.

ANALYSIS BY INDEPENDENT VARIABLES

As stated in the section on the simulator data this will be dealt with in detail in Chapter 6, but a brief description is given here. Since each record contained all the relevant information, the only variable to be calculated was relative velocity. The format of the data records was chosen bearing in mind this calculation. A copy of the program for this is given in Appendix VIII.

CHECKING PROCEDURES

Since the programs for this data were more complex, they were checked very thoroughly to ensure they were doing the correct tasks using both test data and then by running a sample of real data and cross-checking the results with those obtained manually.

The data itself was checked using a program designed to spot any anomalies. Full details on the checking procedures used are given in Appendix IV.

COMPARISON OF THE TWO METHODS OF SECONDARY DATA PREPARATION

In retrospect it was decided that the basic method used for the Sunk data was the better for any future secondary data preparation, as it involved far less preliminary work. With data of the simulator type x, y coordinates could easily be used since each exercise is complete in itself and for the tracing of one exercise it does not matter where the frame of reference is since it is only relative information that is required. It is, however, felt that for the purposes of the thesis it was very instructive to follow through the simulator exercises in detail.

With respect to the calculation of relative velocities, the Sunk data method again involved less data having to be read in and stored although more calculation. If used for the simulator data it would be useful to compare the values obtained for speeds and courses with those given in the students' notes.

One immediate modification which could be made to the Sunk data method is to read in the time-independent variables of tonnage and length as lists against the ship numbers so that the appropriate value could be assigned if required but would not have to be continually carried on each record.

In conclusion in this section, it should be mentioned that the main emphasis in the data processing was to perform the tasks required and not so vitally on performing them in the most efficient method possible. They are therefore presented here as methods which have worked for the job rather than the best possible methods for the situation. It is felt however that they are fairly flexible methods which could easily be adapted to data collected in a different form.

The final section of this chapter will comprise a critical look at the data obtained.

A CRITICAL ANALYSIS OF THE DATA

Following the descriptions of how the data was collected and processed, it is essential to take a critical look at the sort of data produced. Visual examination of Figs. 4.4, 4.5, 4.6, 4.8, 4.9 and 4.10 shows it to be rather 'noisy', so account must be taken of why this should be.

FAULTS COMMON TO BOTH TYPES OF DATA

Some of the reasons for the noise are common to both types of data. Firstly, there is the situation that the ships in an area at one time are not affected by the central ship in question alone but by each other's presence. This is of course capitalised on in taking each ship in turn as the central ship but means that with respect to one ship the positions of the others are not really independent. Again, by looking at the situation every six minutes, there will be a connection between the subsequent positions of two ships relative to each other. When the relative velocities are small this can lead to a concentration of points. If in fact readings were taken every three minutes, say, or at even more frequent intervals, this would become more serious but over a six minute interval the effect is not too marked. For this reason however it was felt that the sample sizes should not be increased by simply taking a shorter time interval.

A third problem is the common statistical problem of having to measure continuous data in discrete classes. The actual choice of classes should not be too critical in this situation as the classes bear no systematic relation to the position of the ships. A class interval of $\frac{1}{10}$ n.mile seemed the most accurate justifiable in these circumstances since smaller intervals would be incompatible with the accuracy of the radar observations and it is only when the number of ships in the total area is small that it is a little unsuitable.

THE SIMULATOR DATA

The data collected from the marine radar simulator has some additional awkward features.

PROBLEMS ARISING FROM THE EXERCISES

The first point which has already been considered (see p. 65) is that at the start of an exercise, time 0, the navigators are not necessarily in positions they would like to be in, but in positions predetermined by the instructor. To overcome this, the results have been obtained omitting the first two positions of the exercise so that the navigator has had a chance to assess the situation and make an alteration if he feels that it is necessary.

A second point arises immediately from this, since the fact that the initial positions of an exercise are predetermined means that there will be peaks in the distributions at certain points, where the various exercises start. These are removed to a certain extent by the omission of time points 0 minutes and 6 minutes but there will still be some effect from this. However, for the early exercises, where all three own ships start at the same point so that 6 repeats of exercise 1, say, would lead to 18 ships in the same position, the point of starting is at a distance greater than 5 miles from the target ships. Thus the ships will in any case be separated by the time their distance from the target ships is less than 5 miles. The main overall effect is that if each exercise, and in particular the early Open Ocean type exercises were to be analysed separately, the distribution of points over the three sectors would not be random. However, taking all exercises together, the effect is not so important, nor in the three main subdivisions of Exercise type viz, Open Ocean, Gibraltar Strait and Dover Strait situations; statistical evidence for this is presented in Appendix IV.

The next consideration arises because the exercises are fundamentally on collision avoidance. Once the particular collision threats have been passed or it has been seen that they will be negotiated, then the exercise is stopped. Thus in many instances only the pattern of relative approach is observed and not the complete pattern of relative separation. The main effect of this has been that the data for Sector 3 is very much less than for the other two sectors, yet this is the largest one in area. Again a statistical discussion of this is given in Appendix IV.

PROBLEMS ARISING FROM A SIMULATED SITUATION

The previous section considered possible reasons for the noise in the data from the simulator. This section considers the important question of

how realistic it is to use a simulated situation as a source of real data anyway, and the sort of effects this is likely to have.

The radar simulator course which the students attend is run very much on discovery lines. Thus the students perform an exercise without any prior discussion of the collision regulations for the type of situation which they are about to encounter. At the start of the course they are familiarised with the controls they have available and they are given time to revise plotting techniques, but no further instruction is given. After each exercise a post mortem is carried out and the reasons for particular manoeuvres are discussed. As this discussion is always held after an exercise has been run it is felt that the performance of a particular officer will be an individual response to a situation and as such provides a valid source of data. The main effect of being in a learning situation is perhaps a tendency to be more cautious than in real life since the student knows that any foolhardy manoeuvres will be picked up and analysed afterwards. However, as the domain is thought of as the area to be kept clear so that navigational worries are minimised for this purpose it is appropriate to have maximum values rather than minimum values as far as caution is concerned. Another possible effect of the learning situation is that as the exercises progress, the actions of the student will be affected by the discussions on previous exercises. However, again the effect will be to produce manoeuvres which minimize the navigational worries, and as the particular situation will in any case be new, the results are still considered very valid.

One real problem which does exist in the simulator data is that the number of ships in the surrounding area is limited and as a result may not be completely realistic, particularly for the Dover Strait exercises. However, as the radius of the domain boundary in any sector is likely to get smaller as traffic density increases and the number of real-life collision threats may not necessarily be any greater than on the simulator, the effect is probably not too marked. This point of course provides the reason why in any case the exercises must not be analysed once the collision threats are averted. In real life there might soon be another collision threat appearing but on the simulator the movement becomes relatively free.

Unfortunately it is not going to be completely straightforward to compare the simulator data and the real-life data as the simulator data is all collected under the assumption of poor visibility and in different sea areas. However, it will still be possible to compare the two on general lines, and in particular to compare the Sunk survey results in good visibility with the Dover Strait simulator results in poor visibility.

One of the first extensions of this project which it is hoped to carry out is to compare data from a simulated and real-life situation where the conditions are as similar as possible. If data can be obtained from ship manoeuvres using a visual simulator this would enable the clear visibility situation to be examined under a number of different factors.

MISCELLANEOUS PROBLEMS

There are two further points which should be mentioned again and borne in mind when considering the results obtained from the simulator data. Firstly, the samples of experience of the navigating officer and the class of ship are not representative of real life distributions. This is inevitably so because of the nature of the course, and is not important for this purpose. Secondly, there is the question of whether more accurate results could be obtained using the digital voltmeter readings on the simulator. The two stage process of tracing from the photoplot and then taking readings from the tracing must inevitably lead to a small amount of error creeping in. However, the photoplot has the advantage that it is a faithful reproduction of what the students see on their screens whereas there is likely to be electrical interference between the radar displays and the voltmeters, so that there could be a discrepancy in the voltmeter readings. It is possible for students to see an end-on collision situation on their radar displays whereas the digital voltmeter readings would suggest it is merely a case of near miss. Also digital voltmeter readings have to be taken sequentially for all the ships in an exercise and the advantage of the photoplot of recording the positions of all ships, instantaneously is considered important. With the additional factor of the time it would take to record the results using the digital voltmeter readings, it is evident that the advantages of objectivity which this method has are clearly outweighed by the advantages of using the photoplot. The slight

degree of subjectivity which might creep in will in any case not cause errors of a larger degree than the variability inherent in the situation anyway.

THE SUNK SURVEY DATA

The data from the Sunk surveys has additional features contributing to noise but of a different nature than those for the simulator data.

The main problem is the loss of radar targets as the distance from the centre of the radar screen, x , increases. This loss is proportional to x^4 as a general rule but varies considerably with the type of target. It was found during the surveys that the trawlers present were not always distinguishable enough for their exact position to be ascertained. A table of comparative echo strengths is given in Appendix IV. Although the exclusion as central ship of those more than 3 miles from the centre will have helped a little, there must inevitably be a falling off in data at greater distances from the centre. It is difficult to compensate for this because of the varying response nature of different types of targets, and is a problem common to all types of survey by radar, both of marine and air traffic flows.

The other factors contributing to the 'noise' but common to all radar work, have been discussed in detail in the previous chapter. They are mainly the presence of sea clutter around the centre of the screen, side-lobing, false echoes and multiple echoes.

Other components of the noise arise because of the nature of the area chosen for the survey. Although attempts have been made to compensate for the different behaviour in a buoyed channel and near the pilot than in an open ocean, it is certain that the effects of these cannot be removed completely. For instance, the grouping of ships around the pilot vessel or in the channel may cause peaks even though they are 3 miles distant say from the central ships being considered. There were a wide variety of exclusions that could have been considered and when more data has been analysed at a later stage it may be possible to take a wider range of exclusions into account. Again, the definition of the channel or pilot neighbourhood was fairly arbitrary in that the navigators would have been making decisions both approaching and leaving these areas based on the fact that they are there.

It should also be noted here that the results obtained in the three different surveys show a significant difference. This might be accounted for by the positioning of the 'Sir John Cass' at different points in the area but it will be examined in greater detail in Chapter 6 as it is quite possibly attributable to the different external conditions prevailing. The statistical analysis on which the conclusion of a difference between the surveys is based is given in Appendix IV.

CONCLUSION

Although the previous paragraphs have tended to be critical of the data in a fairly adverse way in an attempt to account for the noise apparent in it, it should be said in conclusion that they are felt to be adequate for this thesis as will become apparent in the next two chapters. Indeed the results from the simulator data are particularly felt to be encouraging as it is obviously a much more convenient method of conducting maritime research and has great potential for future research projects.

SUMMARY

In this chapter the methods of secondary data production have been discussed. Owing to the different nature of the primary data from the simulator and from the marine traffic surveys, different methods were used in each case, and comparisons drawn between them. In the light of this, a suggested format for future data has been described.

Some basic distributions for both types of data were presented and following on this a critical analysis of the data was given.

CHAPTER 5

Evaluation of the Domain Boundary

INTRODUCTION

Some of the most fundamental problems in the project have been in the establishment of a working definition of the range of the domain boundary from the ship and hence to actually evaluate it. It is suggested that the domange would be a suitable word for the range of the domain boundary from the ship and thus it will be used in this thesis.

The definition chosen should ideally produce an objective method of calculating the domange, relevant to as many situations as possible and sensitive enough to reflect any true differences in behaviour. From the results obtained it should then be possible to test that there actually is a domain present and to establish confidence intervals for the domanges.

This chapter contains a discussion on a variety of approaches to the steps outlined above. Examples of the different methods will be given using data from both available sources, the simulator and Sunk surveys respectively. Comparisons between the results from the two types of data will however be given only in terms of the particular methodology used at any one stage of the discussion. Any differences in the domains in the different situations which become apparent during this chapter will be considered in detail in the following chapter which will look at the effect of different independent variables on a ship's domain. This chapter should therefore be seen as a theoretical study of the evaluation of the boundaries of a ship's domain using practical "noisy" data. The reasons for the noise have been considered in the previous chapter (p. 78).

THE MAIN HYPOTHESIS

It was decided that the simplest method was to work with the distributions of numbers of ships observed in concentric annuli around the 'central ship' with mean radii starting at $\frac{1}{20}$ n.mile and increasing by $\frac{1}{10}$ n.mile to $4\frac{19}{20}$ n.miles. Thus the areas involved were in the ratio

$$1 : 3 : 5 : 7 \dots : (2r-1) : \dots : 99$$

where r is the r^{th} area from the centre.

The main hypothesis is that if the presence of a central ship has no effect then in the simplest situation the distribution of other ships over the area should be uniform.

Hence if K is the uniform density per square mile in the area under observation, the actual numbers in successive annuli should be

$\frac{K\pi}{100}, \frac{3K\pi}{100}, \frac{5K\pi}{100}, \dots, \frac{(2r-1)K\pi}{100}, \dots, \frac{99K\pi}{100}$

The actual analyses are carried out with the total area divided into three sectors, defined by their central angle θ , measured clockwise from the direction of central ship's heading, viz.

- Sector 1 $0^\circ \leq \theta < 112.5^\circ$
- Sector 2 $247.5^\circ \leq \theta < 360^\circ$
- Sector 3 $112.5^\circ \leq \theta < 247.5^\circ$

Thus the areas of the sectors are in the ratio 5 : 5 : 6. For a diagrammatic representation of this situation and a fuller discussion, see Chapter 4, p.59.

The main hypothesis can be restated as follows:- If the central ship has no effect on the distribution of other ships over the surrounding area, then the numbers of ships in successive annuli of any sector will be in the ratio

$1 : 3 : 5 \dots : 2r-1 : \dots : 99.$

If a constant α is now defined dependent on the overall density of shipping and the size of sector considered then for any one sector, the number of ships in successive annuli will be

$\alpha, 3\alpha, 5\alpha, \dots, (2r-1)\alpha, \dots, 99\alpha$

If it is now assumed that the ships are uniformly distributed within each annulus, then the number of ships within an annulus of width δx and of inner radius x , will be given by

$\alpha(x+\delta x)^2 - \alpha x^2$

As $\delta x \rightarrow 0$ then the rate of increase of ships with distance $\rightarrow 2\alpha x$

Thus the curve of increase of numbers of ships is given by the line

$y = 2\alpha x$ if no domain exists.

Handwritten notes on the left margin: $\frac{\pi}{2} = \frac{2\pi}{4}$, $2, 3$, $(\frac{1}{8})$, $\frac{1}{2}$

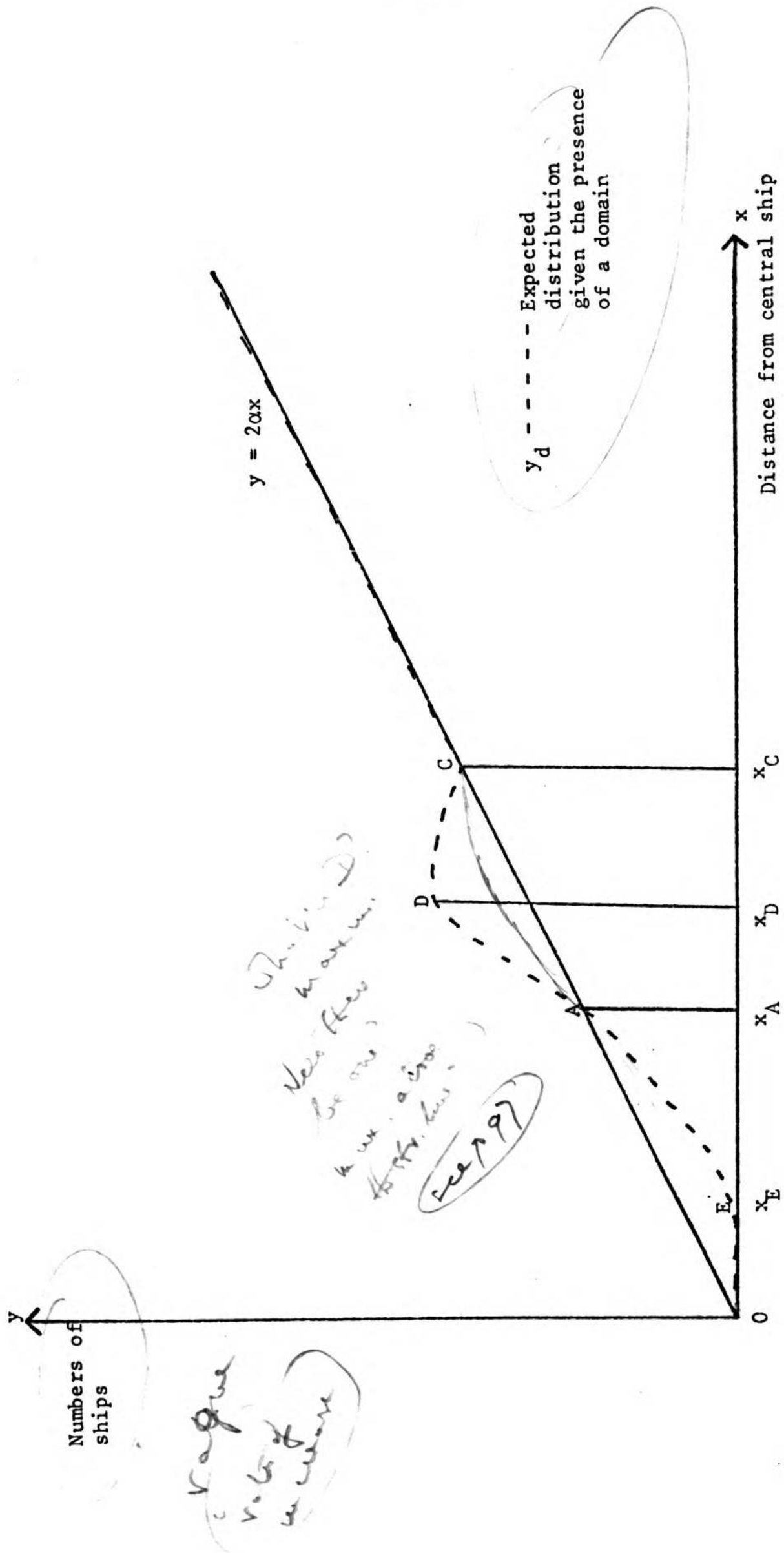

FIG. 5.1 Distribution of Ships Given the Presence of a Domain

However, if there is a domain then with reference to Fig. 5.1 for

$$0 < x < x_A \quad y_d < 2\alpha x$$

$$x_A < x < x_c \quad y_d > 2\alpha x$$

$$x \geq x_c \quad y_d = 2\alpha x$$

$$\text{and } x = x_A \quad y_d = 2\alpha x$$

where y_d is the distribution of the numbers of ships in the presence of the domain.

Since for $0 < x < x_A$, $y_d < 2\alpha x$ and for $x_A < x < x_c$, $y_d > 2\alpha x$, the ships which would have been in the area defined by $0 < x < x_A$, must have moved into the area defined by $x_A < x < x_c$. $x = x_A$ defines the value of x for which $y_d = 2\alpha x$ for the first time.

POSSIBLE DEFINITIONS OF THE DOMANGE

1. The domange could be defined as the nearest distance that anyone is observed to go. This is not very satisfactory as it does not agree with the true concept of a domain, as the area that the navigator would like to keep free, since there is no physical reason why the domain cannot be violated. Hence occasionally there will be ships coming closer than desired perhaps because of misjudgements or inefficient watch keeping. The domange will then be distorted by one extreme value and will not reflect the attitude of the majority of navigators. This definition must also produce very variable results depending on the type of ship and in an extreme case may not even give a safe distance! Of less importance than the previous arguments, there is an additional one that it will however be very difficult to measure accurately using the radar methods employed since there tends to be a merging of targets if the separation distance between them is too small.

Its main advantages as a method are that it is purely objective, very simple to apply and will always give a result. Tables 5.1 and 5.2 give a summary of results obtained using this definition. It is however, felt that the disadvantages far outweigh the advantages.

2. To overcome some of the disadvantages suggested by the first definition, a second criterion might be to take the distance below which only an arbitrary figure such as 10% or 5% of all ships will go.

N. Miles

| SECTOR | EXERCISE NUMBER | | | | | | | | | | | | | | | | | | All open ocean (1,2,3,5,6,7,8,16) | All Gibraltar (9,10,11,12,13) | All Dover Strait (18,19,20) | TOTAL |
|-------------|-----------------|------|------|------|------|------|------|-----|-----|------|-----|-----|------|-----|-----|-----|------|-----|--------------------------------------|----------------------------------|--------------------------------|-------|
| | 1 | 2 | 3 | 5 | 6 | 7 | 8 | 9 | 10 | 11 | 12 | 13 | 16 | 18 | 19 | 20 | | | | | | |
| 1 | .15 | 2.35 | .85 | 1.45 | 1.75 | 2.95 | 1.65 | .15 | .85 | .75 | .25 | .25 | 1.25 | .55 | .55 | .15 | .15 | .15 | .15 | .15 | .15 | |
| 2 | 1.55 | 1.95 | 1.05 | 1.15 | 1.35 | 2.45 | 1.95 | .35 | .55 | 1.15 | .45 | .75 | 1.35 | .75 | .35 | .25 | 1.05 | .35 | .25 | .25 | .25 | |
| 3 | 1.25 | 3.85 | 1.05 | 0.95 | .45 | 2.65 | 3.15 | .45 | .55 | 1.15 | .15 | .75 | .85 | .55 | .15 | .25 | .45 | .15 | .15 | .15 | .15 | |
| SAMPLE SIZE | 18 | 17 | 24 | 16 | 21 | 15 | 9 | 12 | 15 | 6 | 12 | 12 | 6 | 3 | 6 | 15 | 126 | 57 | 24 | 207 | | |

Notes (see p.321)

TABLE 5.1 The Minimum Separation Distance Between Ships in Nautical Miles by Sector and by Exercise Simulator Data

| | N. Miles | | | | |
|---------------------|-------------|-------------|-------------|-------|--|
| | SURVEY 1 | SURVEY 2 | SURVEY 3 | TOTAL | |
| Sector 1 | 0.15 | 0.25 | 0.15 | 0.15 | |
| Sector 2 | 0.15 | 0.15 | 0.35 | 0.15 | |
| Sector 3 | 0.25 | 0.15 | 0.15 | 0.15 | |
| Sample Size (Hours) | 9 | 24 | 15 | 48 | |

Notes (see p.321)

TABLE 5.2 The Minimum Separation Distance Between Ships in Nautical Miles by Sector and by Survey Sunk Data

| Distance from Centre Nautical Miles | SECTOR 1 | | | SECTOR 2 | | | SECTOR 3 | | |
|---|----------------------------|-------------------------|---------|----------------------------|-------------------------|---------|----------------------------|-------------------------|---------|
| | Cumulative Number of Ships | Percentages of Total to | | Cumulative Number of Ships | Percentages of Total to | | Cumulative Number of Ships | Percentages of Total to | |
| | | 2.5N.M. | 5.ON.M. | | 2.5N.M. | 5.ON.M. | | 2.5N.M. | 5.ON.M. |
| 0.1 | 0 | 0.0 | 0.0 | 0 | 0.0 | 0.0 | 0 | 0.0 | 0.0 |
| 0.2 | 3 | 0.8 | 0.3 | 0 | 0.0 | 0.0 | 2 | 0.7 | 0.3 |
| 0.3 | 7 | 1.9 | 0.6 | 1 | 0.2 | 0.1 | 5 | 1.8 | 0.7 |
| 0.4 | 7 | 1.9 | 0.6 | 4 | 1.0 | 0.3 | 6 | 2.2 | 0.8 |
| 0.5 | 9 | 2.4 | 0.8 | 9 | 2.2 | 0.8 | 12 | 4.4 | 1.6 |
| 0.6 | 12 | 3.2 | 1.0 | 11 | 2.7 | 0.9 | 18 | 6.5 | 2.3 |
| 0.7 | 14 | 3.8 | 1.2 | 19 | 4.6 | 1.6 | 22 | 8.0 | 2.9 |
| 0.8 | 20 | 5.4 | 1.7 | 28 | 6.8 | 2.4 | 34 | 12.4 | 4.4 |
| 0.9 | 29 | 7.8 | 2.5 | 37 | 9.0 | 3.1 | 45 | 16.4 | 5.9 |
| 1.0 | 41 | 11.0 | 3.5 | 53 | 13.0 | 4.5 | 52 | 18.9 | 6.8 |
| 1.1 | 50 | 13.4 | 4.3 | 63 | 15.4 | 5.3 | 61 | 22.2 | 7.9 |
| 1.2 | 66 | 17.7 | 5.6 | 83 | 20.3 | 7.0 | 69 | 25.1 | 9.0 |
| 1.3 | 82 | 22.0 | 7.0 | 95 | 23.2 | 8.0 | 82 | 29.8 | 10.7 |
| 1.4 | 98 | 26.3 | 8.3 | 113 | 27.6 | 9.6 | 90 | 32.7 | 11.7 |
| 1.5 | 115 | 30.8 | 9.8 | 129 | 31.5 | 10.9 | 104 | 37.8 | 13.5 |
| 1.6 | 132 | 35.4 | 11.2 | 154 | 37.7 | 13.0 | 121 | 44.0 | 15.7 |
| Total Number of Ships | | 373 | 1174 | | 409 | 1181 | | 275 | 769 |
| Distances Below which only a % of Ships Lie | | | | | | | | | |
| | Nautical Miles | | | | | | | | |
| a% = 5% | | 0.78 | 1.15 | | 0.72 | 1.06 | | 0.53 | 0.84 |
| a% = 10% | | 0.97 | 1.51 | | 0.93 | 1.43 | | 0.75 | 1.26 |

Notes (see p.321)

TABLE 5.3 The Damage Calculations Taking 5% and 10% of the Cumulative Total of Ships to 2.5N.miles and 5.ON.miles by Sector Simulator Data: all Exercises

| Distance from Centre Nautical Miles | SECTOR 1 | | | SECTOR 2 | | | SECTOR 3 | | |
|---|----------------------------|-------------------------|--------|----------------------------|-------------------------|--------|----------------------------|-------------------------|--------|
| | Cumulative Number of Ships | Percentages of Total to | | Cumulative Number of Ships | Percentages of Total to | | Cumulative Number of Ships | Percentages of Total to | |
| | | 2.5N.M | 5.ON.M | | 2.5N.M | 5.ON.M | | 2.5N.M | 5.ON.M |
| 0.1 | 0 | 0.0 | 0.0 | 0 | 0.0 | 0.0 | 0 | 0.0 | 0.0 |
| 0.2 | 0 | 0.0 | 0.0 | 1 | 0.5 | 0.2 | 1 | 0.4 | 0.1 |
| 0.3 | 1 | 0.4 | 0.2 | 3 | 1.6 | 0.7 | 2 | 0.7 | 0.3 |
| 0.4 | 1 | 0.4 | 0.2 | 4 | 2.2 | 0.9 | 3 | 1.1 | 0.4 |
| 0.5 | 4 | 1.8 | 0.7 | 6 | 4.3 | 1.3 | 7 | 2.6 | 1.0 |
| 0.6 | 7 | 3.1 | 1.3 | 6 | 4.3 | 1.3 | 10 | 3.7 | 1.4 |
| 0.7 | 11 | 4.8 | 2.1 | 12 | 6.6 | 2.7 | 14 | 5.1 | 2.0 |
| 0.8 | 16 | 7.0 | 3.0 | 14 | 7.7 | 3.1 | 24 | 8.8 | 3.4 |
| 0.9 | 19 | 8.3 | 3.6 | 17 | 9.3 | 3.8 | 28 | 10.3 | 3.9 |
| 1.0 | 26 | 11.4 | 4.9 | 19 | 10.4 | 4.3 | 41 | 15.1 | 5.8 |
| 1.1 | 39 | 17.1 | 7.3 | 31 | 16.9 | 7.0 | 58 | 21.3 | 8.1 |
| 1.2 | 46 | 20.2 | 8.6 | 41 | 22.4 | 9.2 | 72 | 26.5 | 10.1 |
| 1.3 | 52 | 22.8 | 9.7 | 48 | 26.2 | 10.8 | 83 | 30.5 | 11.7 |
| 1.4 | 62 | 27.2 | 11.6 | 50 | 27.3 | 11.2 | 97 | 35.7 | 13.6 |
| 1.5 | 75 | 32.9 | 14.0 | 58 | 31.7 | 13.0 | 116 | 42.6 | 16.3 |
| 1.6 | 83 | 36.4 | 15.5 | 69 | 37.7 | 15.5 | 128 | 47.1 | 18.0 |
| Total Number of Ships | | 228 | 534 | | 183 | 446 | | 272 | 712 |
| Distances Below which only a % of Ships Lie | | | | | | | | | |
| | Nautical Miles | | | | | | | | |
| a% = 5% | | 0.71 | 1.01 | | 0.63 | 1.03 | | 0.69 | 0.96 |
| a% = 10% | | 0.95 | 1.32 | | 0.96 | 1.25 | | 0.88 | 1.20 |

Notes (see p.321)

TABLE 5.4 The Domange Calculations Taking 5% and 10% of the Cumulative Total of Ships to 2.5N.miles and 5.ON.miles by Sector Sunk Survey Data: Survey 2

| Type of Situation | All Open Ocean 1, 2, 3, 5, 6, 7, 8, 16 | All Gibraltar 9, 10, 11, 12, 13 | All Dover Strait 18, 19, 20 | Total |
|-------------------|--|---------------------------------------|--------------------------------|-------|
| | SECTOR 1 | 361 | 450 | 363 |
| Total (5N.M.) | | | | |
| Fifth Percentile | 1.78 | 1.14 | 0.94 | 1.15 |
| SECTOR 2 | 394 | 583 | 204 | 1181 |
| Total (5N.M.) | | | | |
| Fifth Percentile | 1.64 | 1.03 | 0.76 | 1.06 |
| SECTOR 3 | 165 | 371 | 233 | 769 |
| Total (5N.M.) | | | | |
| Fifth Percentile | 1.16 | 0.91 | 0.63 | 0.84 |
| SAMPLE SIZE | 126 | 57 | 24 | 207 |

Notes (see p.321)

TABLE 5.5 The Fifth Percentiles of the Distributions of Separation Distance (5.0 nautical Miles or Less) By Sector and by Type of Exercise Simulator Data

| | | N. Miles | | | | |
|-------------|---|----------|----------|----------|-------|--|
| | | Survey 1 | Survey 2 | Survey 3 | Total | |
| SECTOR 1 | Total (5N.M.) | 461 | 534 | 406 | 1401 | |
| | Fifth Percentile | 1.08 | 1.01 | 0.94 | 1.00 | |
| SECTOR 2 | Total (5N.M.) | 370 | 446 | 485 | 1301 | |
| | Fifth Percentile | 0.78 | 1.03 | 0.89 | 0.88 | |
| SECTOR 3 | Total (5N.M.) | 669 | 712 | 598 | 1979 | |
| | Fifth Percentile | 0.97 | 0.96 | 0.80 | 0.92 | |
| SAMPLE SIZE | Hours | 9 | 24 | 15 | 48 | |
| | Number of Separations of 5N.Miles or Less | 1500 | 1692 | 1489 | 4681 | |

Notes (see p.321)

TABLE 5.6 The Fifth Percentiles of the Distributions of Separation Distance (5.0 Nautical Miles or Less) by Sector and by Survey Sunk Data

This again is very simple to apply, is objective and will always yield a result. However it is perhaps too arbitrary as in stating that this is the boundary of an area within which navigators would rather not go, no attempt is made to consider the distribution of where they actually do go.

A practical consideration is brought about by the errors in the data and particularly the fall-off in numbers as the range increases. This makes it difficult to decide on the percentage cut off and even more crucially on the area which should be used to base the totals on for calculation of the percentages. This point is illustrated in Tables 5.3 and 5.4. Five nautical miles was chosen as one base range for the area since ships with nearest approaches of that order will hardly be concerned about each other. The other base range of 2.5 nautical miles was chosen since examination of the raw data suggested that the larger errors began after this distance (see p. 78).

The advantages and disadvantages of this method are such that, if using another definition the dimensions of the domain can be established, less arbitrary decisions could be made on the suitable percentage and base area to take and hence the domanges calculated. Tables 5.5 and 5.6 give some results using 5% of the total to 5 nautical miles. The complete results by exercise are given in Table V.1, Appendix V. By comparison with later results, to take 10% of the total distribution to 2.5 nautical miles was considered to give a better solution for the larger categories. However, this did not always yield a solution as the tables V.2 and V.3 (Appendix V) show.

3. Fujii and Tanaka (1971)⁽²³⁾ define the domange to be the distance from the central ship at which the density around it is maximised. They compare the ship situation with the physical situation of two particles with like electric charges approaching each other. The repulsive force increases as the separation decreases. Thus one can assume a potential field around a ship which causes an imaginary repulsive force for approaching ships and a weak attractive force for distant ships. For a simplified situation where all ships are travelling in the same direction, Fig. 5.2 gives a diagram of the wake lines of other ships around a central ship under this hypothesis. There however appears to be little logical basis why on average, ships at a certain distance should be attracted to the central ship. If one considers a cross-section of the wake lines POQ, then Fig. 5.3 shows the

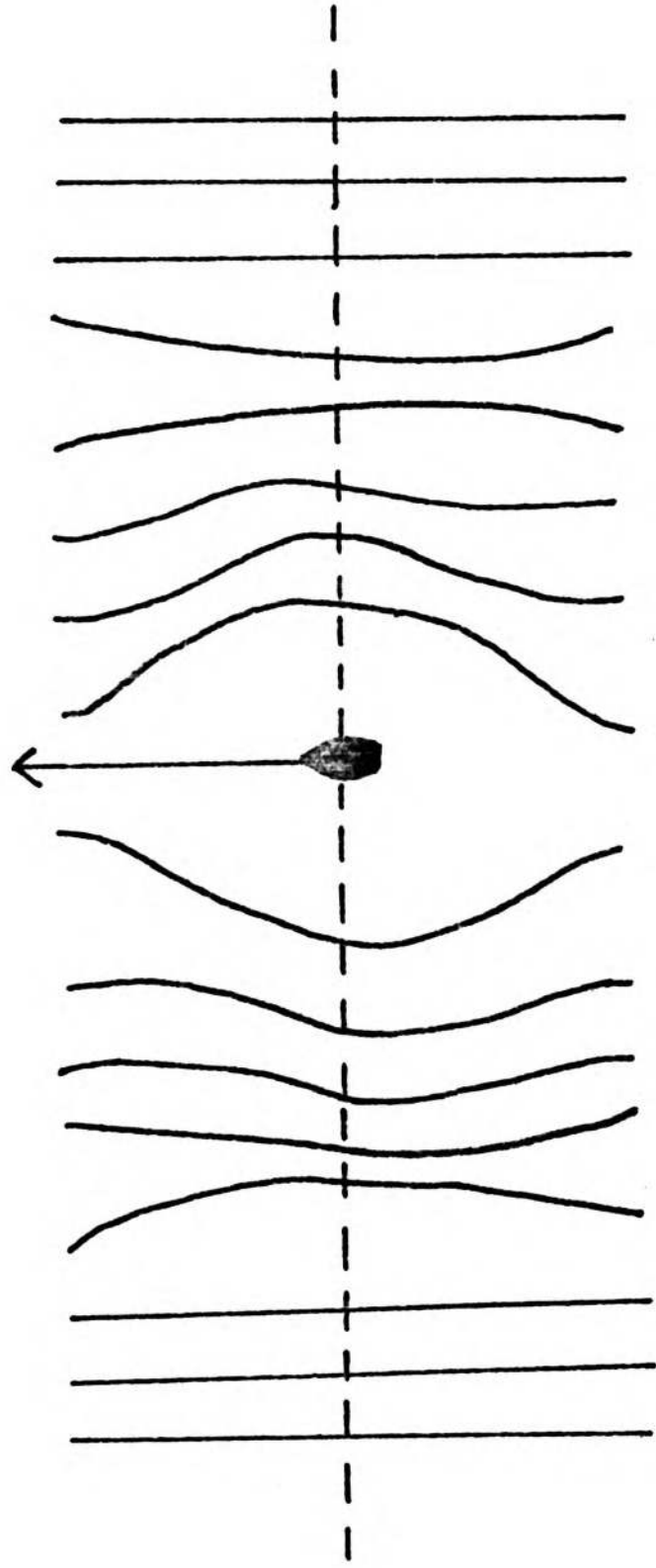

FIG. 5.2 Wake Lines of Ships Around a Central Ship

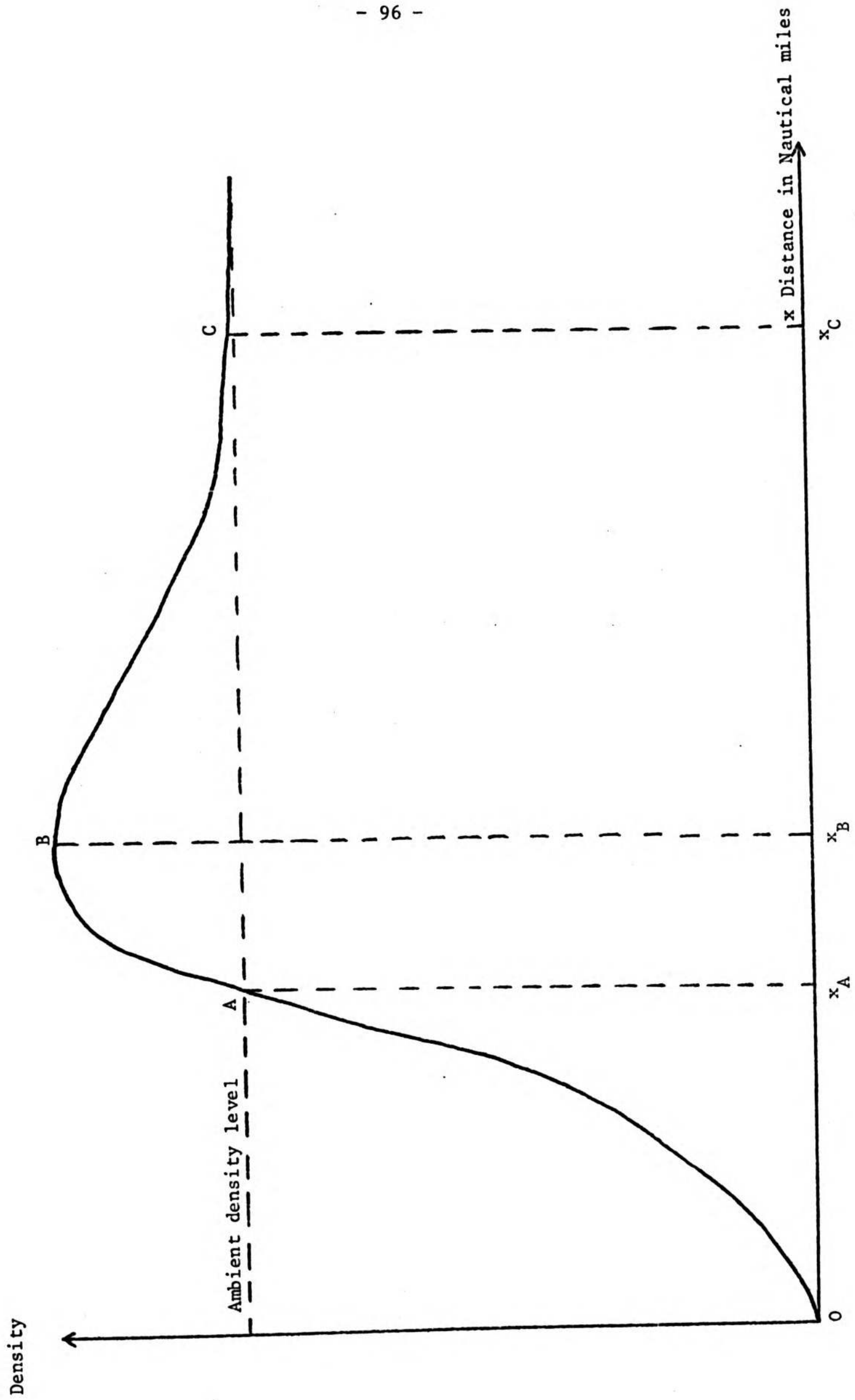

FIG 5.3 Empirical Density Curve

expected density curve for one half of the cross-section (OQ). If the attractive force is working at a distance then the maximum density point will be more pronounced but even without it, the shape of the density curve will be basically the same. Thus if B is the point of maximum density, x_B will be the domange. This definition obviously takes into account the actions of the navigators by considering the distance to which a large number of ships which would seem to have been affected by the presence of the central ship have been displaced to. However, for practical purposes this distance is probably an over conservative value of the domange as ships would be willing to accept smaller distances without causing too many problems. In fact for all the ships at distances less than x_B from the centre this is true. Also the kurtosis of typical curves is such that the maximum is not well defined, particularly in the presence of noise.

Not clear

A further practical point on this definition is that it has been found easier to work with numbers of ships affected by the central ship rather than directly with densities. If one modifies the definition slightly to be the distance at which the numbers of ships are locally maximised during the displacement process (point D in Fig. 5.1), the resulting domange x_D will tend to be very close to x_B as defined above.

rule of thumb

7.26

4. To produce a more realistic definition of a domange which provides the compromise between the minimum and maximum values considered and yet takes into account the behaviour of the ships, it is necessary to reconsider the original hypothesis (p. 85) that given a uniform density the number of ships at any point distance x from the centre can be represented by the line

Point A

$$y = 2ax \quad \text{①}$$

With reference to Fig. 5.1, point A is the first point at which the number of ships is what would have been expected and similarly the first point at which the density reaches the overall density level. The second point at which this happens is point C by which point the disturbance is passed and from then onwards ideally the number of ships will follow the line. Thus point A, where for the first time the situation is equivalent to normal, would seem to provide the most satisfactory point for the domain boundary. It has the important advantage of a simple operational interpretation as marking a boundary, within which the presence of the central ship causes a depletion in the expected number of other ships and immediately outside which there is

45

an enhancement in the expected number of other ships. A further advantage is that a crossing point such as A is easier to locate and is likely to be displaced less by noise than a maximum such as B. It could also be argued that point C where the process is complete could also provide a definition for the domain boundary. However, this is less suitable than the definition giving point A or Fujii's definition for two main reasons. One, it gives an even larger domange and secondly, in practice it will be far more difficult to locate.

which fig?

Having found a definition of the domange in terms of the existing physical situation the next stage is to find a convenient way of estimating it.

POSSIBLE METHODS OF CALCULATING THE DOMANGE

1. GRAPHICAL METHODS

One approach to the problem is to estimate the domange by graphical methods. As was discussed previously the data found was subject to a great deal of random variation so various methods of smoothing were tried on a representative sample of the data.

Let $E(x)$ be the smoothed value
 $Y(x)$ be the actual value } at distance x

[Needs something here]

A. An exponential smoothing of the type

$$E(x) = aY(x) + (1 - a) E(x - 1) \quad (29)$$

was tried for values of a between 0.1 and 0.9. The most satisfactory value was $a = 0.4$ by inspection. However it was decided that this method is not really suitable in this situation as it relies only on past data whereas in these circumstances since both "future" and "past" values of x are known a more efficient method would make use of this. Additionally, although the low value of a gave a smoother curve, it delayed the response to changes to some extent so that some of the important features of the curve were shifted to a higher value of x . The smoothed curve was started in each case with a value of 0. Comparison of Fig. 5.4 showing the actual data for one set of circumstances with Fig. 5.5 showing the same data exponentially smoothed illustrates these points.

what is the value of a?

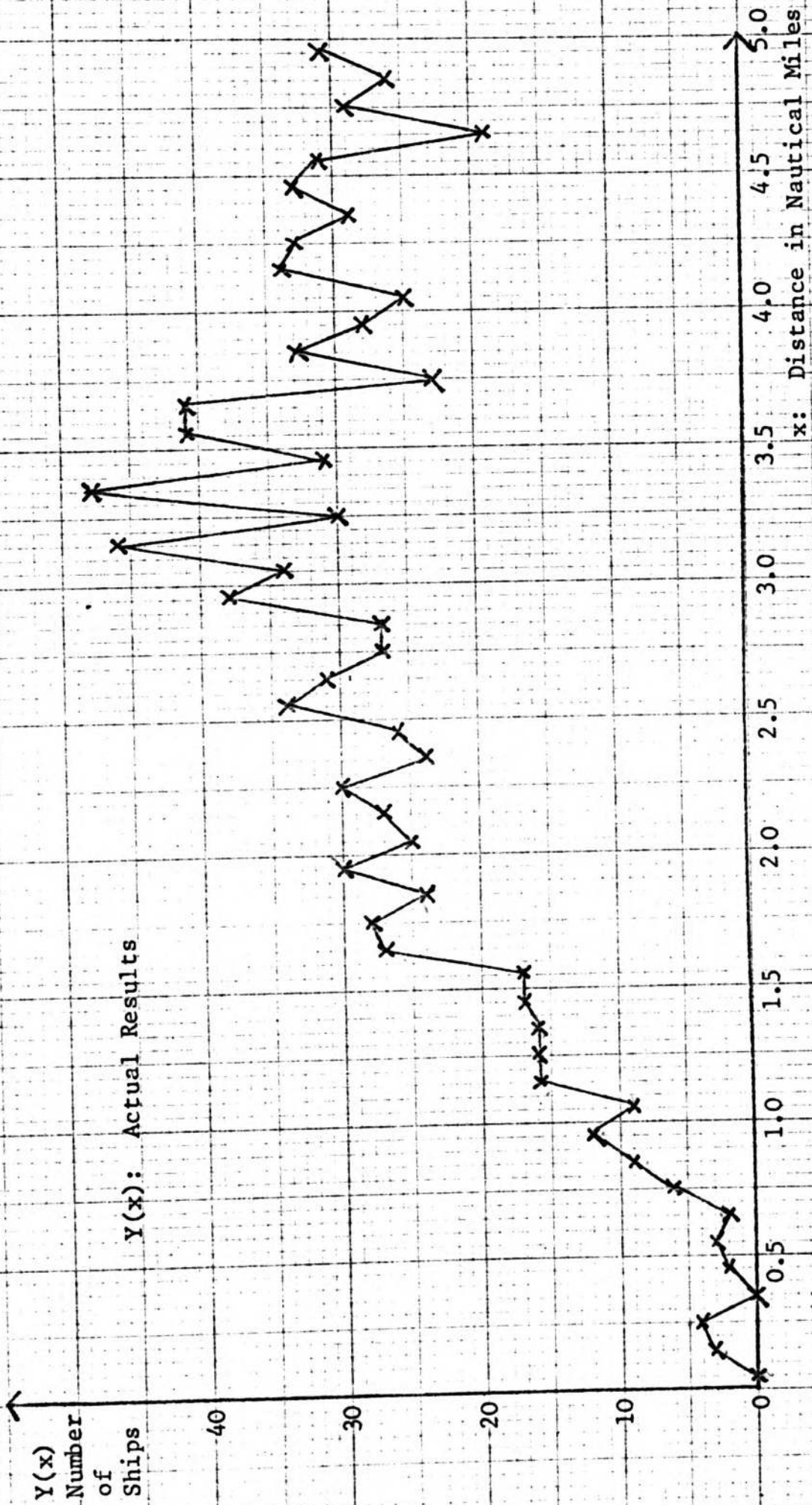

Notes (see p.321)

FIG. 5.4 Simulator Data: All Exercises: Sector 1: Actual Distribution of Ships Around a Central Ship

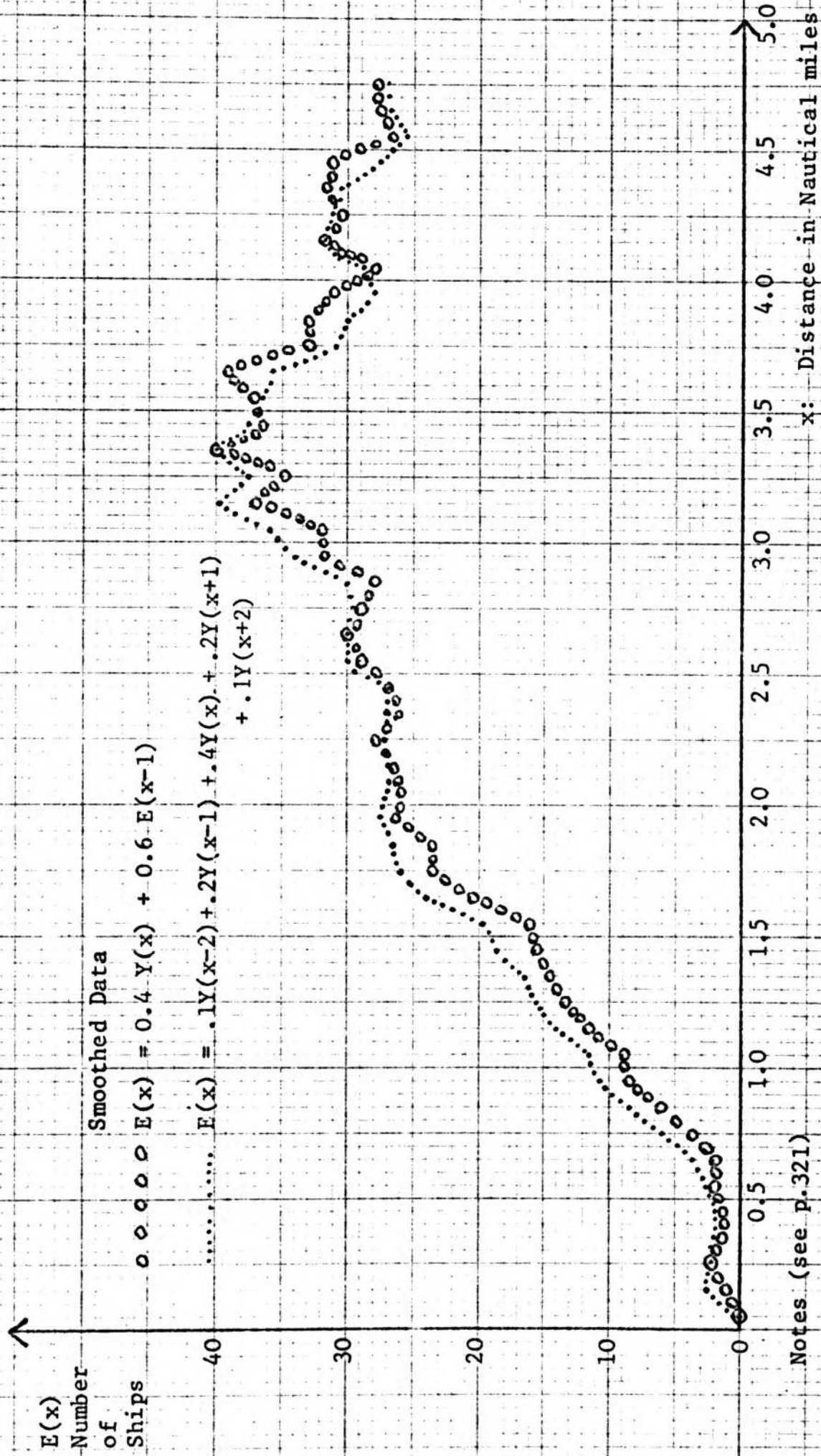

FIG. 5.5 Simulator Data: All Exercises: Sector 1: Smoothed Distributions of Ships Around a Central Ship

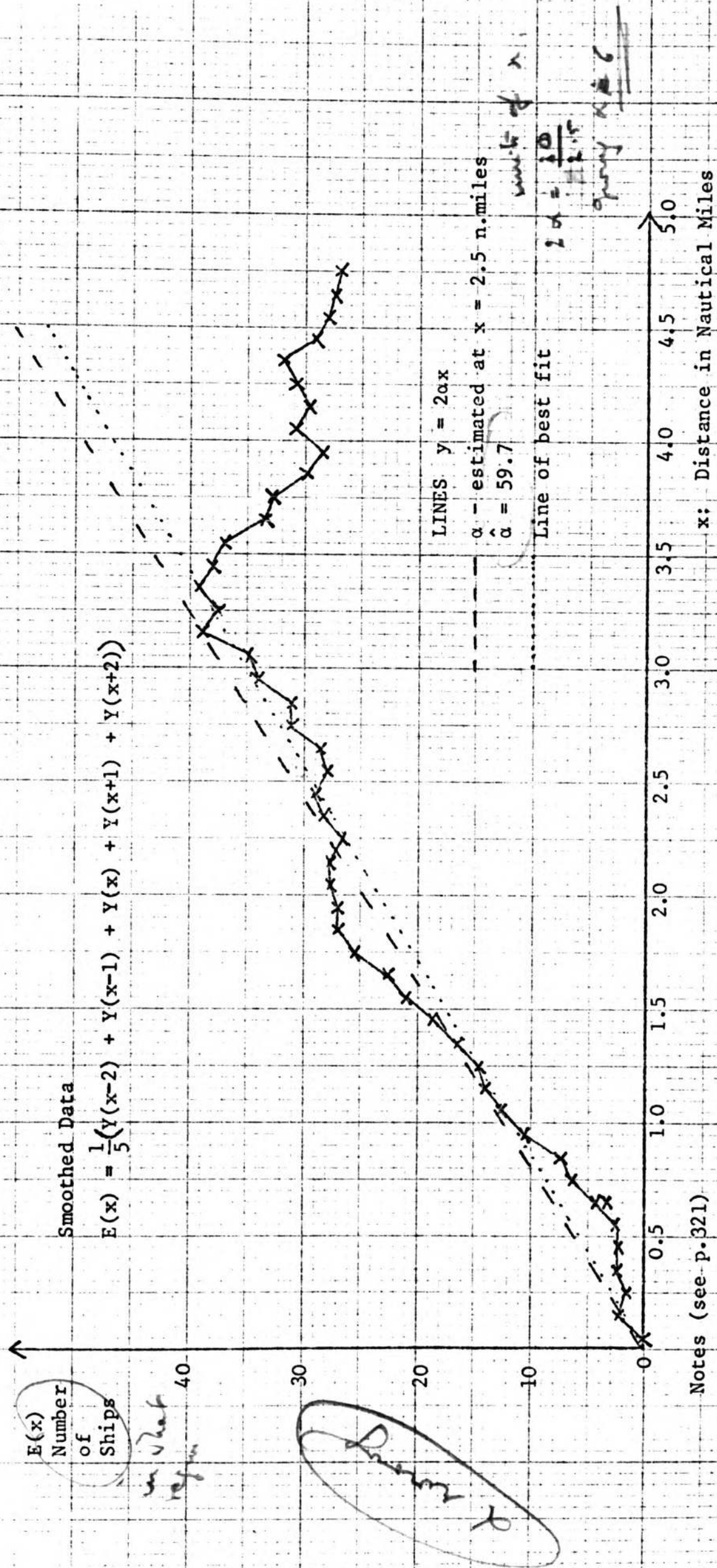

FIG 5.6 Simulator Data: All Exercises: Sector 1: Smoothered Distribution of Ships Around a Central Ship with possible Lines of Uniform Density

B. A weighted moving average with variable weights

$$E(x) = \frac{1}{10}Y(x-2) + \frac{1}{5}Y(x-1) + \frac{2}{5}Y(x) + \frac{1}{5}Y(x+1) + \frac{1}{10}Y(x+2)$$

This average takes into account both preceding and succeeding events but more weight is given to values at the centre of the average than to those further away. *also find*

C. A weighted moving average with fixed weights

$$E(x) = \frac{1}{5}Y(x-2) + \frac{1}{5}Y(x-1) + \frac{1}{5}Y(x) + \frac{1}{5}Y(x+1) + \frac{1}{5}Y(x+2)$$

There is no discernible pattern in the data so the choice of number of periods to be included is not immediately obvious and a decision must be made between simplicity and the number of periods likely to be relevant. Thus five seemed to be the most suitable.

Comparison of Fig. 5.4 (actual data) with Fig. 5.5 (moving average with variable weights) and Fig. 5.6 (moving average with fixed weights) suggests that the moving average with fixed weights gives the more satisfactory curve. Indeed a further comparison among all three types of smoothed curve suggests that this is the most suitable one of all, since the practical results might not be very different but bearing in mind that this is the simplest of all to calculate. Further sets of smoothed curves for the other two sectors of the simulator data and all three sectors for one survey are given in Appendix V (Figs V.1-V.10.)

Having found a way of satisfactorily smoothing the data, a line representing the uniform density situation must be drawn on the graph. It is however not certain what is random variation and what is caused by the displacement process in the formation of a domain. Hence to fit a line by a traditional method such as least squares is inappropriate in this situation.

One solution is to draw subjectively a line of best fit.

A second solution is to attempt to get an estimate of α , for the line of uniform density $y = 2\alpha x$. The total number of ships expected in the total area of outer radius x_1 is

$$\int_0^{x_1} 2\alpha x dx = \alpha x_1^2$$

| N.Miles | | | |
|--|----------|----------|----------|
| | SECTOR 1 | SECTOR 2 | SECTOR 3 |
| A: SIMULATOR DATA: ALL EXERCISES | | | |
| x_A - Distance at which number of ships first equals expected number | | | |
| <i>f</i> Line by calculation | 1.37 | 1.35 | 0.45 |
| <i>v</i> Line of best fit | 1.04 | 1.35 | 0.45 |
| x_D - Distance at which ^{excess} number of ships is locally maximised | | | |
| | 2.05 | 1.85 | 0.65 |
| B: SUNK SURVEY DATA: SURVEY 2 | | | |
| x_A - Distance at which number of ships first equals expected number | | | |
| <i>f</i> Line by calculation | 0.84 | 0.85 | 0.70 |
| <i>f</i> Line of best fit | 0.84 | 0.85 | 0.65 |
| x_D - Distance at which number of ships is locally maximised | | | |
| | 2.45 | 1.95 | 1.25 |

Notes (see p. 321)

TABLE 5.7 The Domain Boundaries in Nautical Miles Obtained by Graphical Methods Using Different Definitions (4 and 3).

A: Simulator Data and B: Sunk Data, Survey 2

Hence if a suitable value of x_i can be found and C_i represents the cumulative total of ships in that area

$$C_i = \hat{\alpha} x_i^2$$

$$\therefore \frac{C_i}{x_i^2} = \hat{\alpha}$$

Inspection of the curves suggest that $x_i = 2.5$ n.miles is in most cases a suitable value to take. After the line is plotted, the damage can be read, and using this method the damage by definition 4 (point A of Fig. 5.1) or definition 3 (point D of Fig. 5.1) could be found. Fig 5.6 and Figs.V.11-V.15 (Appendix V) give an illustration of this method while Table 5.7 gives a summary of the limited results obtained using it.

Although relatively simple, this graphical approach does however have a major disadvantage of subjectivity, in the choice of x_i or in the fitting of the line.

2. ALGEBRAIC EQUATION OF DISPLACEMENT CURVE

Accepting definition 4 as the most reasonable one and given that a graphical method is too subjective the problem is to estimate points A and C and the slope of the line 2α with the very noisy data available.

Various attempts were made to fit a curve that might produce reasonable results. However, the form of the curve that should be taken was not immediately obvious as there were so many unknown parameters. The most reasonable equation seemed to be that of a sine curve superimposed on the straight line as the sine curve has the automatic property of producing decreases then increases.

Thus with reference to Fig. 5.7 the equation tried was

$$y = 2\alpha x - \beta \sin \frac{\pi x}{\gamma} \quad 0 \leq x \leq 2\gamma$$

If when $x = 0$ the curve is parallel to the x axis

$$\frac{dy}{dx} = 2\alpha - \frac{\beta\pi}{\gamma} \cos \frac{\pi x}{\gamma}$$

$$\Rightarrow 0 = 2\alpha - \frac{\beta\pi}{\gamma}$$

$$\Rightarrow \beta = \frac{2\alpha\gamma}{\pi}$$

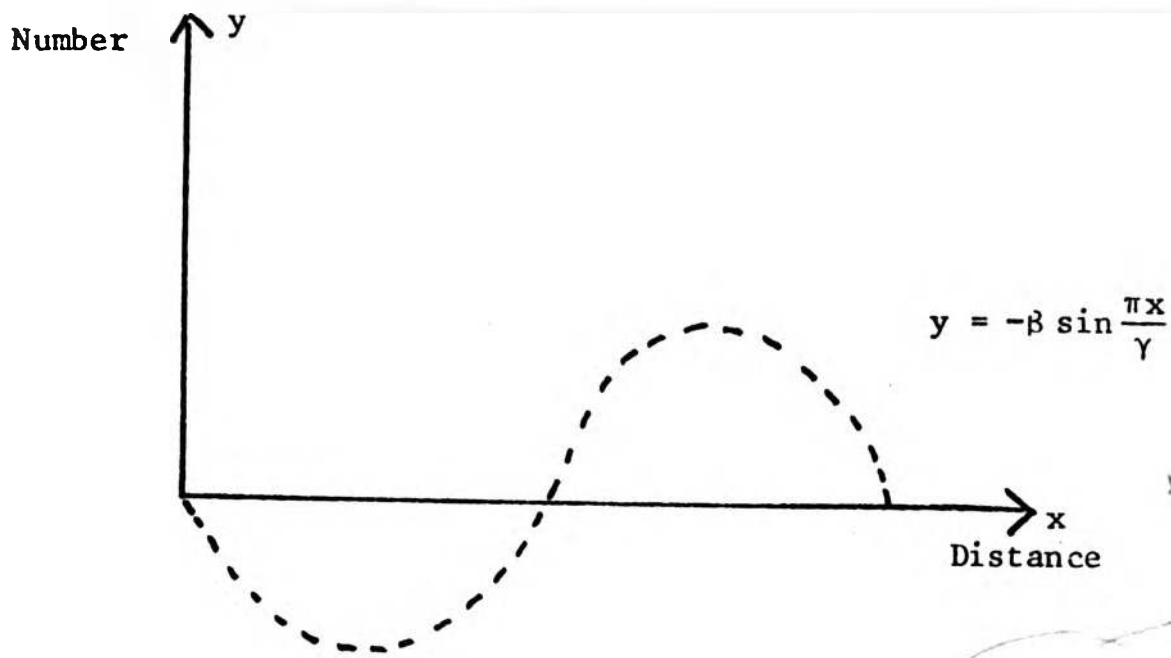

(i) Possible form of displacement around uniform density line

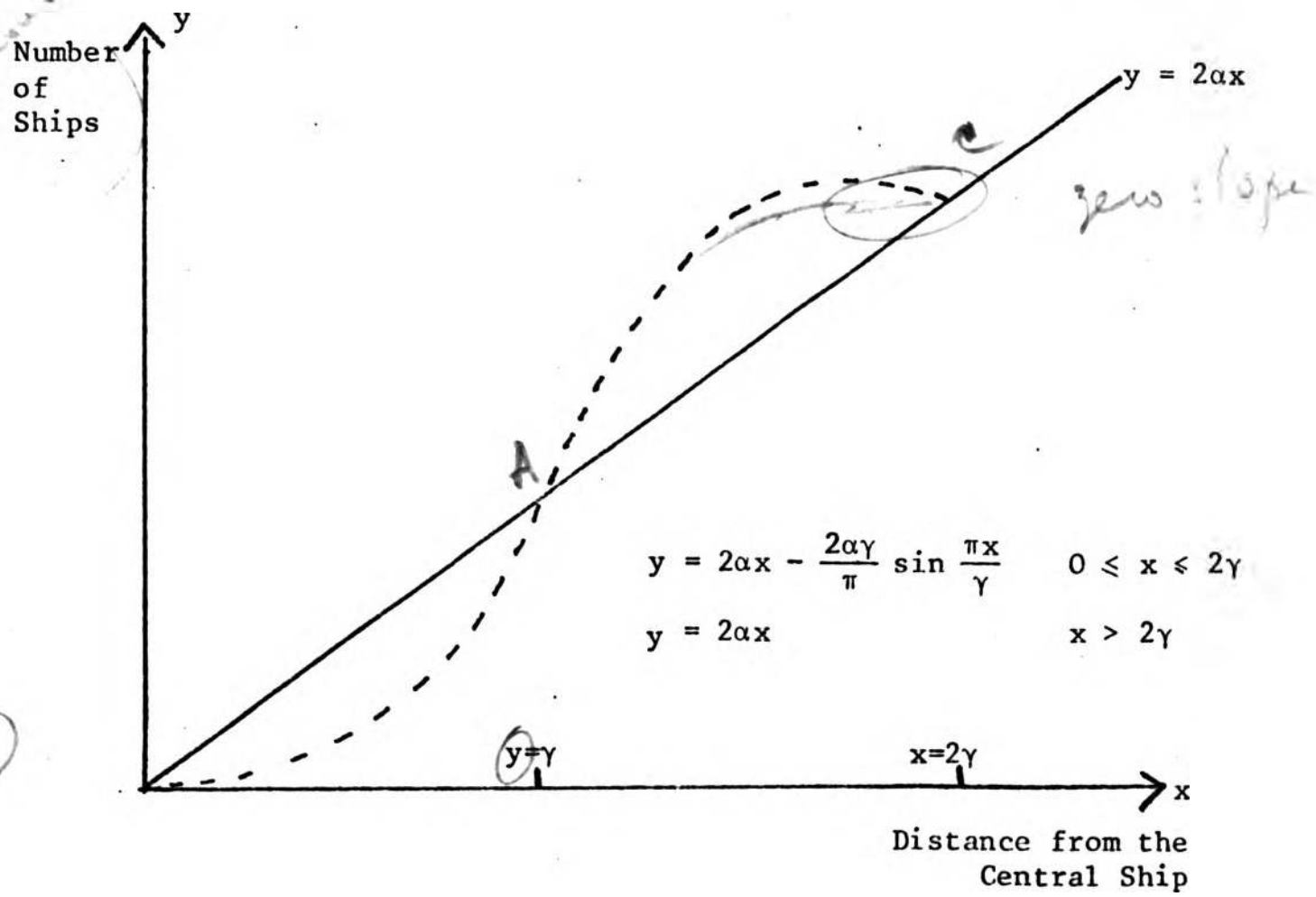

(ii) The associated Distribution of Ships

FIG. 5.7 A sine curve form displacement and its extension to give a possible distribution of ships around a central ship

$$\therefore \left. \begin{aligned} y &= 2\alpha x - \frac{2\alpha\gamma}{\pi} \sin \frac{\pi x}{\gamma} & 0 \leq x \leq 2\gamma \\ y &= 2\alpha x & 2\gamma < x \end{aligned} \right\}$$

The second constraint in this equation is that at **A**, $x = \gamma$ and at **C** $x = 2\gamma$ which is probably not necessarily true.

If one considers the fit of this curve up to a point where $x = x_F$, where $x_F \geq 2\gamma$; then

$$(1) \text{ Number of ships} = \int_0^{x_F} \left(2\alpha x - \frac{2\alpha\gamma}{\pi} \sin \frac{\pi x}{\gamma} \right) dx$$

$$= \alpha x_F^2 \quad (\text{for } x_F \geq 2\gamma)$$

$$(2) \text{ Mean of distribution of ships} = \frac{1}{\alpha x_F^2} \int_0^{x_F} \left(2\alpha x^2 - \frac{2\alpha\gamma x}{\pi} \sin \frac{\pi x}{\gamma} \right) dx$$

$$= \frac{1}{\alpha x_F^2} \left[\frac{2\alpha x_F^3}{3} + \frac{4\alpha\gamma^3}{\pi^2} \right] = \frac{2x_F}{3} - \frac{4\gamma^3}{\pi^2 x_F^2}$$

Equating observed and expected means

$$\bar{x} \cdot x_F^2 = \frac{2x_F^3}{3} + \frac{4\gamma^3}{\pi^2} \quad \text{where } \bar{x} \text{ is the observed mean of the distribution of ships}$$

$$\Rightarrow \left[\bar{x} x_F^2 - \frac{2}{3} x_F^3 \right] \frac{\pi^2}{4} = \gamma^3$$

$$\Rightarrow \bar{x}^3 = \frac{2.50}{16} (\bar{x} - 1.667) = 15.5 (\bar{x} - 1.67)$$

Tables 5.8 and 5.9 show results that were obtained using this method taking $x_F = 2.5$ n.miles. However the data was in many cases too poor to produce any results, particularly if the fall-off after the domain effect was too great. It is also felt that a choice of 2.5 n.miles is too arbitrary a figure. Table 5.10 illustrates the variety of results that may be obtained for one set of circumstances, fitting the curve up to 1.0, 1.5, 2.0 and 2.5 miles respectively. This is again a reflection of the poor quality of the data. Additionally the choice of 2.5 n.miles will not always mean that the displacement process is over by then as later results will show. Thus the results obtained are not always under the correct assumptions.

Handwritten notes at the bottom right of the page.

$$\therefore \left. \begin{aligned} y &= 2\alpha x - \frac{2\alpha\gamma}{\pi} \sin \frac{\pi x}{\gamma} & 0 \leq x \leq 2\gamma \\ y &= 2\alpha x & 2\gamma < x \end{aligned} \right\}$$

The second constraint in this equation is that at (A) $x = \gamma$ and at (C) $x = 2\gamma$ which is probably not necessarily true.

If one considers the fit of this curve up to a point where $x = x_F$, where $x_F \geq 2\gamma$; then

(1) Number of ships = $\int_0^{x_F} \left(2\alpha x - \frac{2\alpha\gamma}{\pi} \sin \frac{\pi x}{\gamma} \right) dx$ *no.*
 = αx_F^2 (for $x_F \geq 2\gamma$) *expl. $\int_0^w - \int_w^{x_F}$*

(2) Mean of distribution of ships = $\frac{1}{\alpha x_F^2} \int_0^{x_F} \left(2\alpha x^2 - \frac{2\alpha\gamma x}{\pi} \sin \frac{\pi x}{\gamma} \right) dx$
 = $\frac{1}{\alpha x_F^2} \left[\frac{2\alpha x_F^3}{3} + \frac{4\alpha\gamma^3}{\pi^2} \right] = \frac{2x_F}{3} + \frac{4\gamma^3}{\pi^2 x_F^2}$

Equating observed and expected means

$\bar{x} \cdot x_F^2 = \frac{2x_F^3}{3} + \frac{4\gamma^3}{\pi^2}$ where \bar{x} is the observed mean of the distribution of ships

$\Rightarrow \left[\bar{x} x_F^2 - \frac{2}{3} x_F^3 \right] \frac{\pi^2}{4} = \gamma^3$
 $\Rightarrow \bar{x} = \frac{2.5}{4} (\bar{x} - \frac{2}{3} \times 2.5) \frac{10}{4} = \bar{x}^2$
 $\Rightarrow \bar{x} = \frac{2.50}{16} (\bar{x} - 1.667) = 15.5 (\bar{x} - 1.67)$

Tables 5.8 and 5.9 show results that were obtained using this method taking $x_F = 2.5$ n.miles. However the data was in many cases too poor to produce any results, particularly if the fall-off after the domain effect was too great. It is also felt that a choice of 2.5 n.miles is too arbitrary a figure. Table 5.10 illustrates the variety of results that may be obtained for one set of circumstances, fitting the curve up to 1.0, 1.5, 2.0 and 2.5 miles respectively. This is again a reflection of the poor quality of the data. Additionally the choice of 2.5 n.miles will not always mean that the displacement process is over by then as later results will show. Thus the results obtained are not always under the correct assumptions.

Handwritten notes:
 1.1.6
 1.1.6

| Simulator Data | Domange x_A | N. Miles | |
|----------------|------------------|-------------------|-----------------|
| | | Mean \bar{x} | No. of Ships |
| ALL EXERCISES | | | |
| Sector 1 | 0.95 | 1.72 | 373 |
| Sector 2 | 0.92 | 1.72 | 409 |
| Sector 3 | - | 1.59 | 275 |
| DOVER STRAIT | | | |
| Sector 1 | - | 1.57 | 142 |
| Sector 2 | - | 1.53 | 104 |
| Sector 3 | - | 1.54 | 114 |
| GIBRALTAR | | | |
| Sector 1 | 1.15 | 1.77 | 171 |
| Sector 2 | 1.09 | 1.75 | 237 |
| Sector 3 | - | 1.66 | 133 |
| OPEN OCEAN | | | |
| Sector 1 | 1.64 | 1.95 | 60 |
| Sector 2 | 1.51 | 1.89 | 68 |
| Sector 3 | - | 1.50 | 28 |

*Why
left
x_A for
Sector 2*

Notes (see p.321)

- No value obtainable

TABLE 5.8 Values of the Domange in Nautical Miles Using a Sine Curve Approximation Fitted to 2.5N. Miles by Sector and by Type of Sea Area Simulator Data

| | | | N. Miles |
|-------------|------------------|-------------------|-----------------|
| Sunk Survey | Domange x_A | Mean \bar{x} | No. of Ships |
| SURVEY 1 | | | |
| Sector 1 | 0.88 | 1.71 | 137 |
| Sector 2 | - | 1.65 | 158 |
| Sector 3 | 0.96 | 1.73 | 265 |
| SURVEY 2 | | | |
| Sector 1 | 1.12 | 1.76 | 228 |
| Sector 2 | 0.70 | 1.69 | 183 |
| Sector 3 | - | 1.63 | 272 |
| SURVEY 3 | | | |
| Sector 1 | 0.36 | 1.67 | 165 |
| Sector 2 | - | 1.61 | 197 |
| Sector 3 | - | 1.60 | 248 |

Notes (see p.321)

- No value obtainable

Does this mean anything?

TABLE 5.9 Values of Domange Using a Sine Curve Approximation Fitted to 2.5 N. Miles by Sector Sunk Data

| N. miles | | | | |
|-------------------------------------|---------------|--------------|----------------|--|
| Dover Strait | Domange x_A | No. of Ships | Mean \bar{x} | Expected Mean Under Uniform Distribution |
| Curve fitted to $x_F = 1.0$ n.miles | | | | |
| Sector 1 | 0.38 | 22 | 0.69 | 0.67 |
| Sector 2 | 0.67 | 24 | 0.76 | 0.67 |
| Sector 3 | - | 25 | 0.61 | 0.67 |
| Curve fitted to $x_F = 1.5$ n.miles | | | | |
| Sector 1 | 0.71 | 63 | 1.06 | 1.00 |
| Sector 2 | 0.30 | 49 | 1.01 | 1.00 |
| Sector 3 | - | 47 | 0.94 | 1.00 |
| Curve fitted to $x_F = 2.0$ n.miles | | | | |
| Sector 1 | 0.46 | 105 | 1.34 | 1.33 |
| Sector 2 | - | 80 | 1.30 | 1.33 |
| Sector 3 | - | 84 | 1.30 | 1.33 |
| Curve fitted to $x_F = 2.5$ n.miles | | | | |
| Sector 1 | - | 142 | 1.57 | 1.67 |
| Sector 2 | - | 104 | 1.53 | 1.67 |
| Sector 3 | - | 114 | 1.54 | 1.67 |

Notes (see p.321)

- No value obtainable

TABLE 5.10 Values of the Domange in Nautical Miles Using a Sine Curve Approximation Fitted to Different Distances by Sector Simulator Data: Dover Strait Exercises

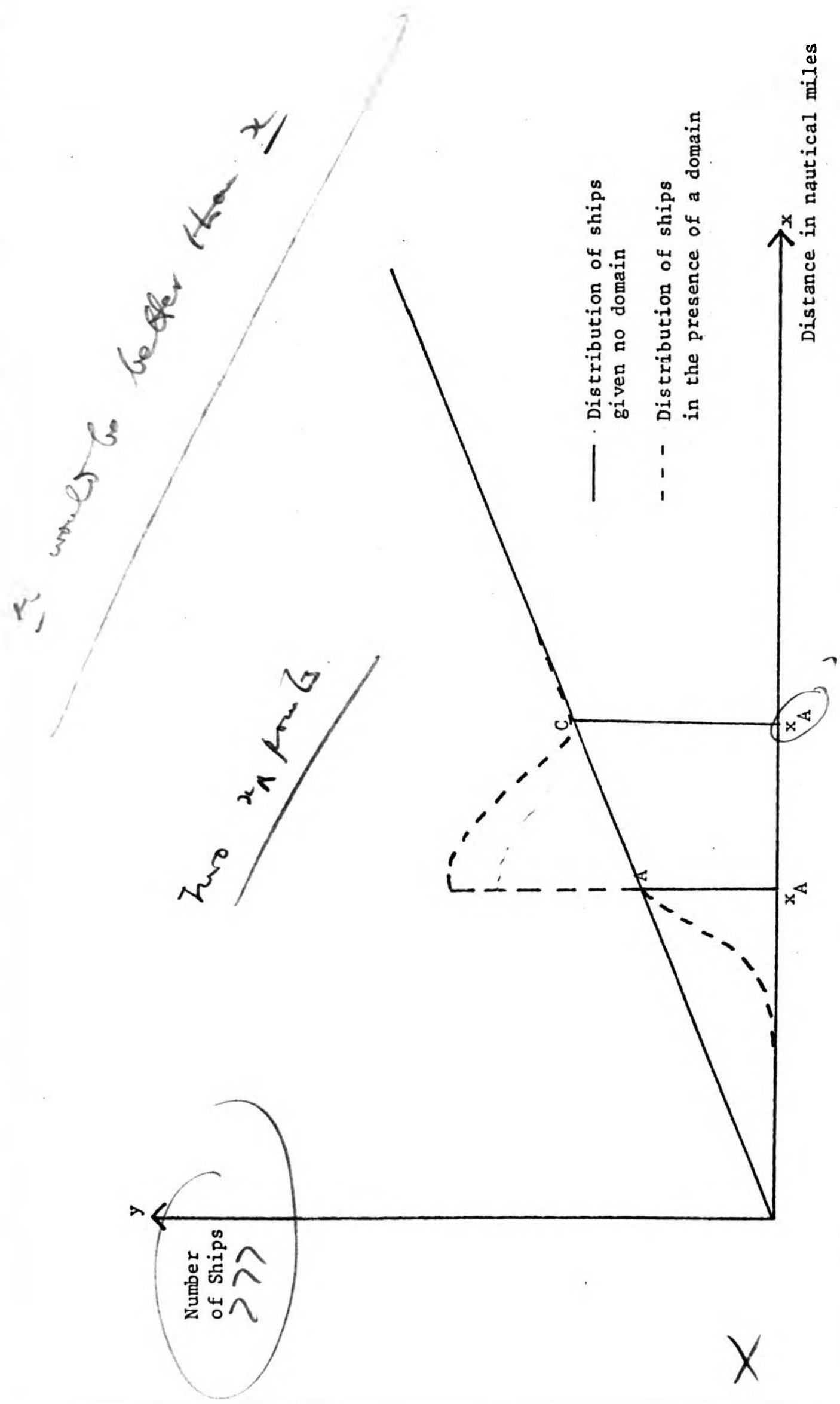

FIG. 5.8 The Distribution of Ships Given a Normal Distribution about the Domain Boundary for all Ships Displaced from the Domain

Another interesting point is that it was difficult to get any results for sector 3 suggesting that in this sector a sine curve is certainly not a suitable model for displacement.

It is however felt that an approach of this type should in theory be very useful. A possible future line of research might be the development of an analytic curve to fit the data.

Another approach considered on these lines was to develop a model in terms of the displacement of each individual ship rather than to fit a curve to the resulting pattern. A very simple assumption would be to say that for each ship that would be closer than x_A miles to the central ship the desired separation distance will become x_A miles but there will be a normal distribution of distance about x_A . However, ships at a distance of just greater than x_A miles are likely to be displaced slightly as well, so that the picture becomes rather confused. If one assumes that ships at a separation distance greater than or equal to x_A miles are not displaced then the resulting distribution would be as in Fig. 5.8. This does not appear to be the resulting pattern and obviously the assumption is a great oversimplification of the pattern. Methods on this basis have therefore not been pursued further.

MTV clear

3. METHOD OF DISPLACED NUMBERS

(i) Description of the Method

The most satisfactory single method developed makes no assumptions on what the resulting displacements look like but uses the fact that when point C is reached (Fig. 5.2) the total number of ships in the area defined by $x < x_C$ will equal the total number of ships expected in the area given a uniform density. Let y_i be the number of ships in the i^{th} band from the centre with outside radius x_i and mean radius $m_i = \frac{x_{i-1} + x_i}{2}$.

5.7 or 5.3

X

If $y = 2\alpha x$ is the line given uniform density for the distribution of ships, the total number of ships expected in the total area of outer width x_i is

$$\int_0^{x_i} 2\alpha x dx = \alpha x_i^2$$

Number of ships expected in band $i =$

$$\int_{x_{i-1}}^{x_i} 2\alpha x \, dx = \alpha(x_i^2 - x_{i-1}^2)$$

$$= \alpha(x_i - x_{i-1})(2m_i)$$

on assumption of uniform density.

For equal width bands $(x_i - x_{i-1}) = \text{constant}$
 $= .1 \text{ n.miles for this data}$

\therefore an estimate of α is given by

$$\frac{\hat{\alpha} m_i}{5} = y_i$$

(define y_i)

Assumes uniform density of equal to that observed in the 1st band.

\therefore to edge of i^{th} band an estimate of the expected number of ships

is $\frac{5y_i}{m_i} x_i^2 = T_i$

on what assumption?

Let $C_i = \sum_{k=1}^i y_k$ - thus C_i is the actual number of ships to the edge of the i^{th} band.

Hence the distance x_C is given by $x_C = x_i^*$

where x_i^* is the first point where $C_i = T_i$.

For successive values of i , C_i and T_i can be calculated and hence the point C found (x_i^*, y_i^*) . By joining (x_i^*, y_i^*) to the origin the line of uniform density can be seen and the point of intersection between the line and the plotted curve of observed values is the point A. Hence the value of the damage x_A can be read off. In practice, a few modifications can be made to the method, to help in the determination of x_A .

(a) As the determination of the damage depends on a graphical approach ultimately, it is better to smooth the data first, substituting y_{si} for y_i , where y_{si} is the smoothed value. It was decided that in this case it was better to use a shorter period moving average to make it easier to locate point C. Since x_C is expected to be about 2.5 n.miles, the end of the displacement process and the fall off in data became too easily confused if the data is too smooth. Even at smaller distances, the longer period moving averages tended to make the results less sensitive. Thus the moving average used was

$$y_{si} = \frac{1}{3}(x_{i-1} + x_i + x_{i+1}).$$

since equal weights were simpler to calculate and give a smoother result than one having variable weights such as $y_{si} = \frac{1}{3}x_{i-1} + \frac{1}{3}x_i + \frac{1}{3}x_{i+1}$.

$$\text{Then } T_{si} = \frac{5y_{si}}{m_i} \cdot x_i^2$$

(b) There should be more than one point where $C_i = T_i$, after the initial point, since the hypothesis is that the data will differ only by random fluctuations from the uniform density line after the effect of the domain has worn off, although in practice there are other disturbing influences preventing this after a certain point. However, there should be at least one further point confirming the findings. This can be useful in determining which point (x_i^*, y_i^*) to take if there appears to be a choice.

Table 5.11 together with Fig. 5.9 show the determination of the domange for a reasonably well behaved set of circumstances. T_{si} is consistently greater than C_{si} until the band of outer radius 1 mile. The sign of the difference $T_{si} - C_{si}$ fluctuates after this point.

expected - a - hand

| $\frac{x_i}{10}$ N.Miles | Sign of $T_{si} - C_{si}$ | $\frac{x_i}{10}$ N.Miles | Sign of $T_{si} - C_{si}$ |
|--------------------------|---------------------------|--------------------------|---------------------------|
| 1 | | 14 | - |
| 2 | + | 15 | - |
| 3 | + | 16 | - |
| 4 | + | 17 | + |
| 5 | + | 18 | + |
| 6 | + | 19 | - |
| 7 | + | 20 | - |
| 8 | + | 21 | - |
| 9 | + | 22 | - |
| 10 | - * | 23 | - |
| 11 | - | 24 | - |
| 12 | + | 25 | - |
| 13 | + | 26 | - |

Notes (see p.321)

* $(x_i^*, y_i^*) = (0.95, 8.3)$ point C

TABLE 5.11 Calculation of the Domain Boundary by the Method of Displaced Numbers
Sunk Data: : Survey 3 : Sector 3

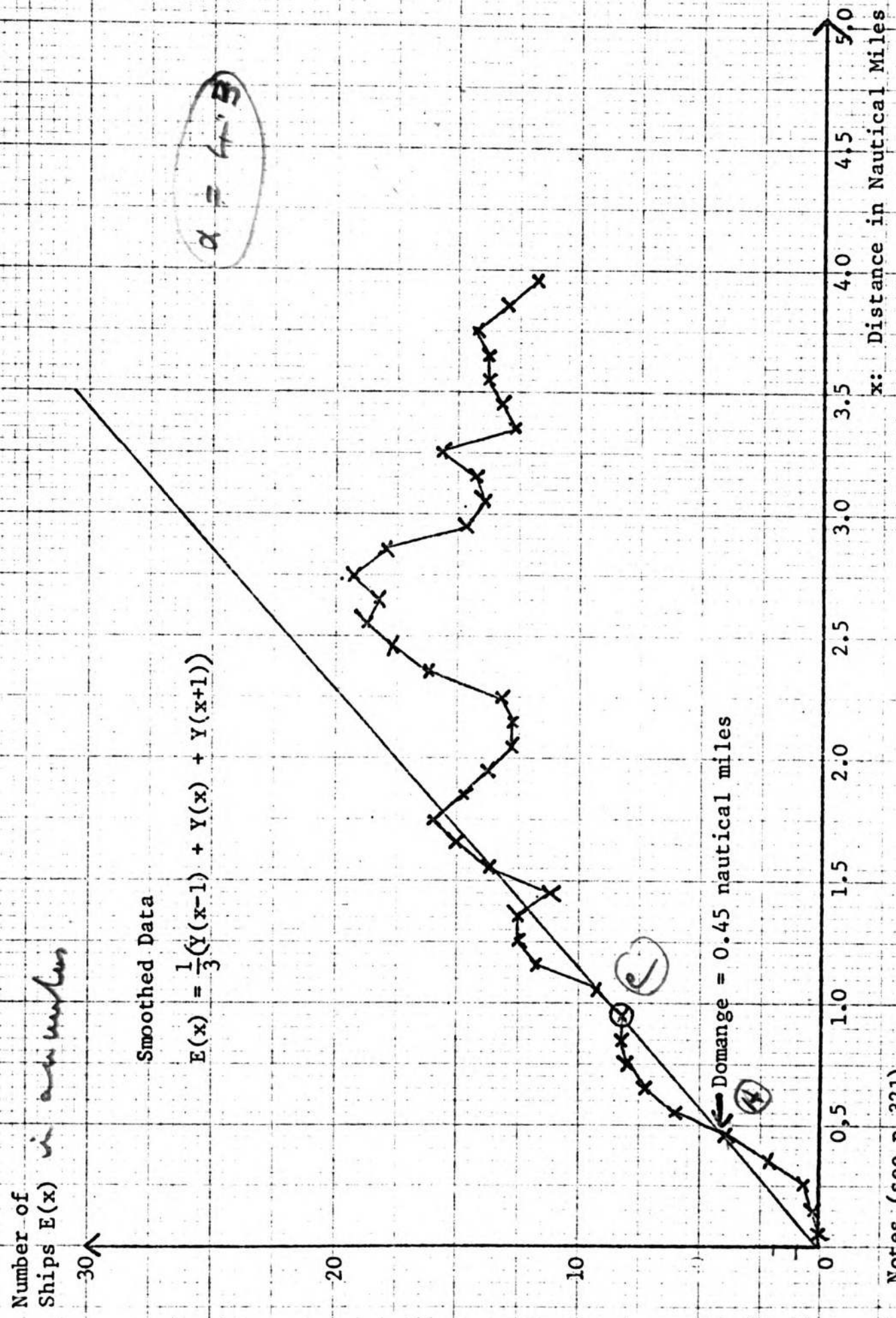

Notes (see p. 321)

FIG. 5.9 Sunk Survey Data: Survey 3: Sector 3: Evaluation of the Domange

(c) An unusually high or low value of y_{si} with respect to the distance from the centre can cause some doubt as to which really is point C. For instance, the presence of one or two ships very close to the central ship can give a very small value of x_i^* . It is considered that this should be ignored if it is based on a cumulative total of less than 10 ships provided the sample size overall is large enough. When reading the value of x_A from the graph the initial peak may also cause complications here but it is suggested that it should again be ignored.

An illustration of this is given in Table 5.12 and Fig. 5.10. The effect of the initial peak in this case is so marked as to make the value of C_{si} larger than T_{si} whereas in most cases it should be smaller. It has been found in a situation such as this that the change of sign from - to + after 0.80 miles even though the cumulative total is 20 ships should be ignored and point C located where there is a change of sign from + to -, in this case after 2.30 miles. The effect of the peak initially is also evident on the graph.

| $\frac{x_i}{10}$ N.Miles | Sign of $T_{si} - C_{si}$ | $\frac{x_i}{10}$ N.Miles | Sign of $T_{si} - C_{si}$ |
|--------------------------|---------------------------|--------------------------|---------------------------|
| 1 | + | 16 | + |
| 2 | + | 17 | + |
| 3 | - | 18 | + |
| 4 | - | 19 | + |
| 5 | - | 20 | + |
| 6 | - | 21 | + |
| 7 | - | 22 | + |
| 8 | + | 23 | - * |
| 9 | + | 24 | - |
| 10 | + | 25 | - |
| 11 | + | 26 | - |
| 12 | + | 27 | - |
| 13 | + | 28 | - |
| 14 | + | 29 | - |
| 15 | + | 30 | - |

Notes (see p.321)

* $(x_i^*, y_i^*) = (2.25, 27)$ point C

TABLE 5.12 Calculation of the Domain Boundary by the Method of Displaced Numbers
 Simulator Data : All Exercises : Sector 1

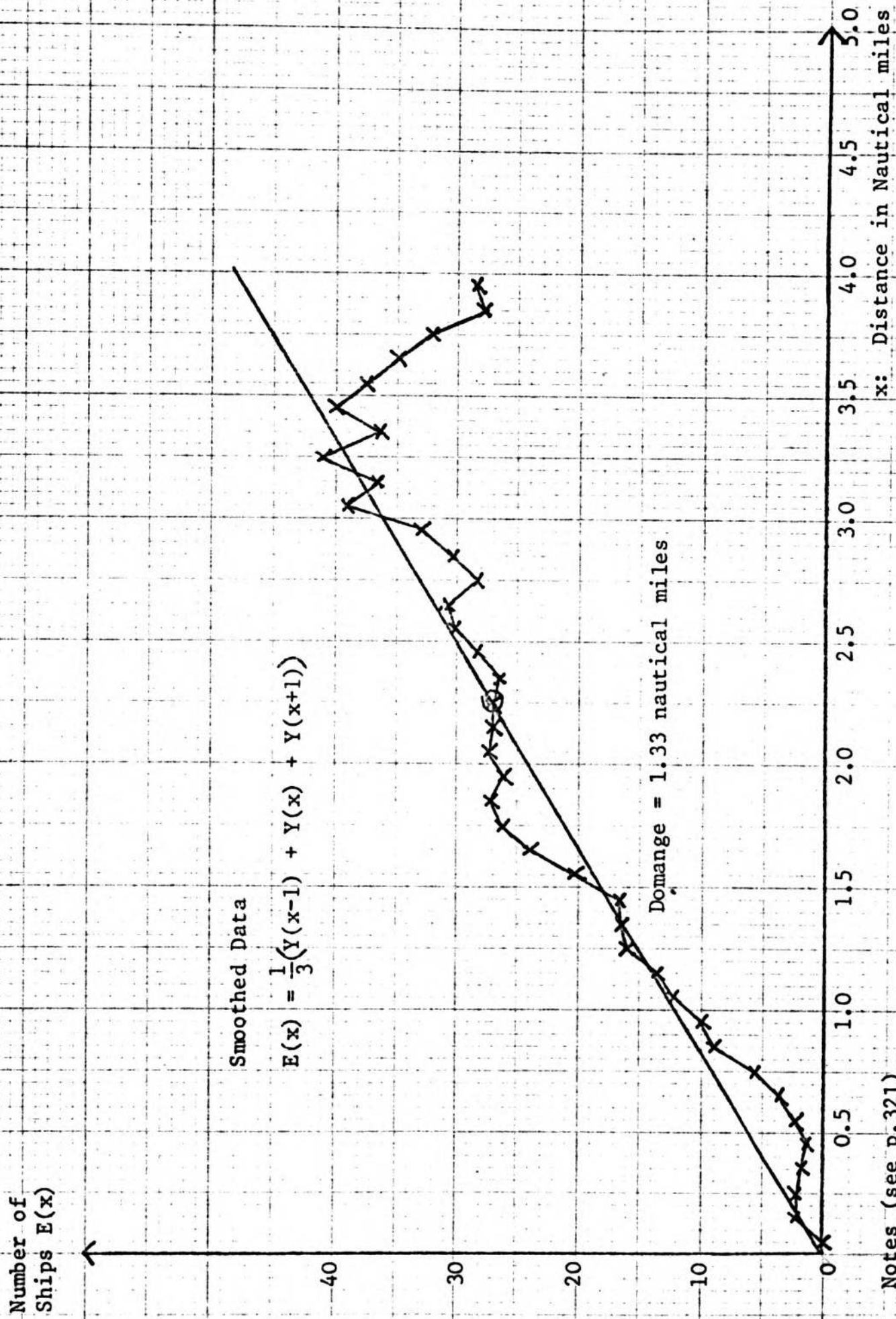

Notes (see p.321)

FIG. 5.10 Simulator Data: All Exercises: Sector 1: Evaluation of the Domange

The effect can still be noticeable if the abnormal values occur at a greater distance from the central ship. Consideration of Table 5.13 and Fig. 5.11 shows the effect of this. The unsmoothed data is rather erratic about 1.2 nautical miles, and at a distance of 1.4 nautical miles the sign of $T_{si} - C_{si}$ changes for one value only. As the change is so temporary and the resulting line does not 'fit' the data, it seems better to ignore it. Further work suggests that a temporary fluctuation of one value should be ignored.

| $\frac{1}{10} x_i$ N.Miles | Sign of $T_{si} - C_{si}$ | $\frac{1}{10} x_i$ N.Miles | Sign of $T_{si} - C_{si}$ |
|-------------------------------|------------------------------|-------------------------------|------------------------------|
| 1 | | 16 | + |
| 2 | | 17 | + |
| 3 | + | 18 | + |
| 4 | + | 19 | + |
| 5 | + | 20 | + |
| 6 | + | 21 | + |
| 7 | + | 22 | + |
| 8 | + | 23 | + |
| 9 | + | 24 | + |
| 10 | + | 25 | + |
| 11 | + | 26 | - * |
| 12 | + | 27 | - |
| 13 | + | 28 | - |
| 14 | - | 29 | - |
| 15 | + | 30 | - |

Notes (see p.321)

* $(x_i^*, y_i^*) = (2.55, 17.7)$ point C

TABLE 5.13 Calculation of the Domain Boundary by the Method of Displaced Numbers
Simulator Data : Gibraltar : Sector 2

(d) If there is fluctuation around the value of the domange which is not readily resolvable, the mean value should be taken. Fig. 5.10 provides a suitable illustration of this.

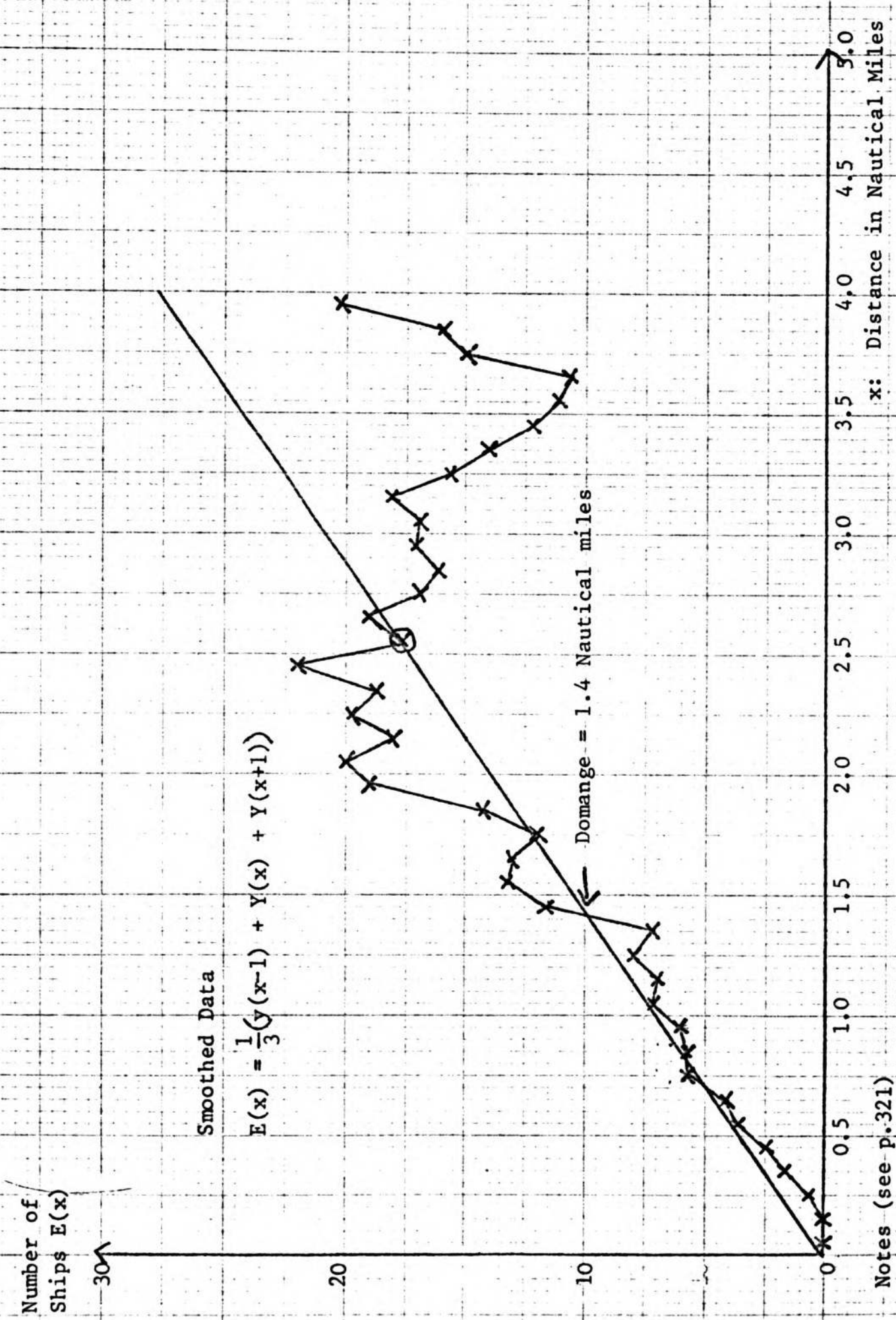

Notes (see p.321)

FIG. 5:11 Simulator Data: Gibraltar Exercises: Sector 2: Evaluation of the Domange

(e) There may occasionally be circumstances when there is more than one point at which $C_i = T_i$ and rather conflicting results occur. It has been found that it is usually possible to resolve the situation using one of the ideas mentioned above. If there are circumstances other than those which can be resolved by the methods mentioned above when the first and second points at which equality occurs do give conflicting results, then the situation may have to be resolved subjectively.

(ii) Advantages and Disadvantages of the Method

Mr
clear

It is felt that this is the most satisfactory method developed so far because it takes into account the behaviour of the ships under the displacement hypothesis. It is thus superior to the more objective methods considered, which could be used in any situation and take no notice of whether a domain is present or not. Because it is based on an objective principle, it is hence superior to a purely graphical approach. Its advantages over a curve fitting method are that it will yield results even with poor data and of course it is unnecessary to make any further assumptions about the form of displacement curve.

The calculations are readily computerised and the program used for this purpose is given in Appendix VIII.

However there are still disadvantages present. The main one is of course, that there is still a degree of subjectivity left both in the choice of point C and point A. Secondly, the method is not completely computerisable since the final determination is by graphical methods. Although routines do exist for plotting graphs by computer, they are limited by the discrete spacing of characters in the print out. It was therefore considered better to plot the graphs by hand to increase the accuracy, although with any graphical method, accuracy is bound to suffer to some extent. Thus it is realized that the method is by no means ideal but at least it provides some results which for the most part seem reasonably realistic. Table 5.14 provides a summary of results obtained under different conditions.

It is considered that the results generally are of the right order and certainly they reflect a difference between the various navigational areas. One would expect much higher values in the Open Ocean where there is considerable freedom to manoeuvre, than in the

Page 119

| SIMULATOR DATA | N. Miles | | |
|---------------------------------------|----------|----------|----------|
| | SECTOR 1 | SECTOR 2 | SECTOR 3 |
| All Exercises | 1.33 | 0.78 | 0.45 |
| Dover Strait 18, 19, 20 | 0.82 | 0.77 | 0.10 |
| Gibraltar 9, 10, 11, 12, 13 | 1.49 | 1.40 | 0.57 |
| Open Ocean 1, 2, 3, 5, 6, 7, 8, 16 | 2.35 | 2.35 | 0.85 |

Notes (see p.321)

| SUNK DATA | SECTOR 1 | SECTOR 2 | SECTOR 3 |
|-------------|----------|----------|----------|
| All Surveys | 0.85 | 0.70 | 0.45 |
| Survey 1 | 0.47 | 0.50 | 0.35 |
| Survey 2 | 0.87 | 0.91 | 0.78 |
| Survey 3 | 0.71 | 0.58 | 0.45 |

Notes (see p.321)

TABLE 5.14 The Domain Boundaries for Different Conditions
A: Simulator Data by Sector and by Type of Sea Area
B: Sunk Data by Sector and by Survey

Dover Strait where the amount of navigable water is severely restricted and there are many more ships around. It also seems reasonable that the values for the Dover Strait in poor visibility should be similar to those for the southern North Sea in good visibility. These points will be examined in much greater detail in the following chapter, but the values of the domanges are included here as examples of the method.

A summary of this method of displaced numbers is presented in Appendix V, together with further examples of the resulting graphs. Also given in Appendix V are the complete calculations for the three examples discussed in this chapter and whose results were summarised in tables 5.11, 5.12 and 5.13.

4. SLOPE METHOD

The final method which is considered worth mentioning is one to locate the best estimate of the slope of the line $y = 2\alpha x$.

The total number of ships in the area with outer boundary x_i is αx_i .

Thus if y_i is the number actually observed in the i^{th} band and C_i is the cumulative total in the area including and inside the i^{th} band

$$C_i = \sum_{K=1}^i y_K = \hat{\alpha} x_i^2$$

$$\text{Thus } \hat{\alpha} = \frac{C_i}{x_i^2}$$

Given the existence of a domain, the estimates of α , should thus vary with i . For small x_i , the estimates of α will be small but they will gradually rise until they settle down to a stable level. If the stable level can be estimated, then this gives the necessary information to plot the line of uniform density. Unfortunately, because of the different processes present it is not easy to establish this level. However, it is useful for finding a rough estimate of α , and also of the location of point C, so it can provide a check for the results obtained by the previous method. As an illustration of this method, consider the situation represented in Fig. 5.10, viz:- simulator data, all exercises, sector 1. Table 5.15 below contains the successive estimates of α made using the formula $\hat{\alpha} = \frac{C_i}{x_i^2}$

5.116

| $\frac{1}{10} x_i$ N.Mile | $\hat{\alpha}$ | $\frac{1}{10} x_i$ N.Mile | $\hat{\alpha}$ | $\frac{1}{10} x_i$ N.Mile | $\hat{\alpha}$ |
|------------------------------|----------------|------------------------------|----------------|------------------------------|----------------|
| 1 | 0 | 13 | 48.5 | 25 | 59.4 |
| 2 | 75.0 | 14 | 50.0 | 26 | 60.3 |
| 3 | 77.8 | 15 | 51.1 | 27 | 60.1 |
| 4 | 43.8 | 16 | 51.5 | 28 | 59.3 |
| 5 | 36.5 | 17 | 55.0 | 29 | 58.5 |
| 6 | 33.3 | 18 | 57.7 | 30 | 58.7 |
| 7 | 28.5 | 19 | 58.6 | 31 | 58.6 |
| 8 | 30.5 | 20 | 60.2 | 32 | 59.4 |
| 9 | 35.8 | 21 | 60.3 | 33 | 58.7 |
| 10 | 41.0 | 22 | 60.5 | 34 | 59.4 |
| 11 | 41.4 | 23 | 61.1 | 35 | 59.6 |
| 12 | 45.9 | 24 | 60.3 | 36 | 58.6 |

changes / 1/10 mile

Notes (see p.321)

TABLE 5.15 Estimates of the Slope of the Line of Uniform Density for the Calculation of the Domange by the Slope Method: Simulator Data : All Exercises : Sector 1.

Not clear

For $x_i \leq 2.3$ $\hat{\alpha}$ can be considered to be increasing

For $x_i > 3.6$ $\hat{\alpha}$ can be considered to be decreasing

$\therefore \hat{\alpha}$ is stable for $2.4 \leq x_i \leq 3.6$ (n.v.)

Thus the mean value of $\hat{\alpha}$, $\bar{\alpha} = 59.4$, and point C is to be located at $x_i \approx 2.35$ n.miles. For comparison purposes by the method of displaced numbers C is found to be at $x_i \approx 2.35$ n.miles and $\hat{\alpha} \approx 58.5$. A further example of this method using the situation shown in Fig. 5.9 is given in Appendix V. With more data it might be possible to make more use of this method.

HYPOTHESIS TESTS FOR THE PRESENCE OF A DOMAIN

Once a line of uniform density has been established it is a desirable idea to test if the hypothesis of the presence of a domain is substantiated. Therefore it is required to test a null hypothesis

H_0 : no domain exists and the underlying pattern is one of uniform density

against the alternative hypothesis

H_1 : a domain exists

A maximum significance level of 5% is considered appropriate.

If uniform density exists then one would expect the points to be roughly in equal numbers on either side of the line of uniform density whether the data is smoothed or not. However if a domain exists then for $x < x_A$ (domange) the points will all be below the line and for $x_A < x < x_C$ (x_C - end of displacement) the points will all be above the line (see Fig. 5.2). Above x_C the points will again be randomly scattered with equal numbers approximately on either side of the line. Thus for $x < x_C$ the number of points in the direction of the domain and against it can be counted. Under H_0 if the points are randomly scattered about the line then each point has an equal chance of being in the direction of the domain or against it.

Thus if Z is a random variable denoting the number of points out of n in the direction of the domain, Z has a binomial distribution with parameters n and $\frac{1}{2}$.

Hence if z is the observed value of Z the probability ($Z \leq z \mid H_0$ is true) can be evaluated. Since a maximum significance level $\alpha = 5\%$ is to be taken, any situation for which probability ($Z \leq z \mid H_0$ is true) $< .05$ can be considered to be significant. Thus it may be inferred that a pattern other than uniform density most probably exists which is the pattern in the presence of the domain.

Table 5.16 shows the results for the different classes of simulator exercises by sector and Table 5.17 has the similar results for the three Sunk surveys by sector. The first two columns in each of the tables show the number of values of the distributions of ships around the central ship which lie in the direction expected by the domain and against the direction expected by the domain respectively for all $x < x_C$. x_C is a variable for each situation hence the total number of values shown in the third column is different for each situation. The final column contains the probability ($Z \leq z \mid H_0$ is true) as defined above. Of the 24 results, only one is non-significant, which fact must in itself provide convincing evidence of the presence of the domain. The one contrary result, Dover Strait exercises, Sector 3, is in any case considered to have an unrealistic value for the domange. The other values are nearly all very much less than the critical value of .05. Ideally one would like to test the values for $x > x_C$ to see if they are significantly different from uniform density, but this is not practical because of the fall off in data.

| Simulator Data | No of Values in the Direction of the Domain | No of Values against the Domain | Total No. of Values | Probability |
|----------------|---|---------------------------------|---------------------|-------------|
| ALL EXERCISES | | | | |
| Sector 1 | 18 | 4 | 22 | .0022 |
| Sector 2 | 26 | 1 | 27 | .0000 |
| Sector 3 | 8 | 1 | 9 | .0195 |
| DOVER STRAIT | | | | |
| Sector 1 | 14 | 1 | 15 | .0005 |
| Sector 2 | 11 | 0 | 11 | .0005 |
| Sector 3 | 4 | 0 | 4 | .0625 |
| GIBRALTAR | | | | |
| Sector 1 | 21 | 1 | 22 | .0000 |
| Sector 2 | 23 | 2 | 25 | .0000 |
| Sector 3 | 10 | 0 | 10 | .0010 |
| OPEN OCEAN | | | | |
| Sector 1 | 38 | 0 | 38 | .0000 |
| Sector 2 | 37 | 3 | 40 | .0000 |
| Sector 3 | 11 | 2 | 13 | .0112 |

Notes (see p. 321)

TABLE 5.16 Results of Hypothesis Tests on the Presence of a Domain: Simulator Data by Sector and by Type of Sea Area

| Sunk Data | No of Values in the Direction of the Domain | No of Values against the Domain | Total No. of Values | Probability |
|-------------|--|--|------------------------|-------------|
| SURVEY 1 | | | | |
| Sector 1 | 7 | 0 | 7 | .0078 |
| Sector 2 | 8 | 0 | 8 | .0039 |
| Sector 3 | 7 | 0 | 7 | .0078 |
| SURVEY 2 | | | | |
| Sector 1 | 16 | 1 | 17 | .0001 |
| Sector 2 | 11 | 1 | 12 | .0032 |
| Sector 3 | 15 | 0 | 15 | .0000 |
| SURVEY 3 | | | | |
| Sector 1 | 14 | 2 | 16 | .0021 |
| Sector 2 | 10 | 3 | 13 | .0461 |
| Sector 3 | 9 | 0 | 9 | .0020 |
| ALL SURVEYS | | | | |
| Sector 1 | 14 | 2 | 16 | .0021 |
| Sector 2 | 10 | 3 | 13 | .0461 |
| Sector 3 | 19 | 0 | 19 | .0000 |

Notes (see p.321)

TABLE 5.17 Results of Hypothesis Tests on the Presence of a Domain: Sunk Data by Sector and by Survey

STANDARD ERRORS OF THE DOMAIN BOUNDARIES

Since the results obtained are obviously sample results, they provide only a point estimate of the true figures for the domain boundary. It would thus be useful if confidence intervals could be established for the population results. To do this, however, the sampling distribution of the domain boundary must be investigated.

One approach tried using the sunk data was to take random samples of four hours and to attempt to calculate the domain boundary for each sample. However this proved rather unsuccessful as the sample sizes were small. As the size of the sample is obviously a relevant factor, this was hardly surprising.

The second approach involved making an assumption about the form of the underlying distribution in the presence of the domain. In an earlier section (p.111) it was suggested that an oversimplification of the process might be to imagine a distance x_A from the central ship, whereby all ships at a distance greater than x_A were not affected at all, and those at a distance of less than x_A were displaced to x_A with a normal distribution about that point. This obviously requires perfect information as to where each ship is with respect to the central ship.

Although dismissed in connection with the calculation of the domain boundary, it is felt that it might provide a basis for some indication of the variability of the results.

With reference to Fig. 5.8, if x_A is the distance around which the normal distribution is centred, confidence intervals for x_A are given by

$$\hat{x}_A \pm z_\alpha \cdot \frac{\hat{\sigma}}{\sqrt{n}}$$

where \hat{x}_A is the value of x_A from the sample results

$\hat{\sigma}^2$ is the estimated variance among the ships which are displaced

n is the number of ships displaced

and z_α is the probability factor derived from standard normal tables if the sample is large enough and from 't' tables if not.

It was decided that the best estimate of σ would be to take the standard deviation of all the ships within a distance $0 \leq x \leq x_C$ from the central ship. This is obviously not correct as many of the ships in the area so defined are not involved in the displacement process but

it probably overestimates σ which is wisest in these circumstances.

To estimate n , use was once more made of the equation that the number of ships expected in a total area of outer radius x_i under uniform density is αx_i^2 .

Thus if the cumulative total to x_C is C_C

$$C_C = \hat{\alpha} x_C^2$$
$$\therefore \hat{\alpha} = \frac{C_C}{x_C^2}$$

Therefore the cumulative total to $x_A = n$ is given by $n = C_C \frac{x_A^2}{x_C^2}$

*Body
extends*

x_A and x_C are as found by the method of displaced numbers.

Table 5.18 gives a summary of the values of the standard errors

(2) $\left(\frac{\hat{\sigma}}{\sqrt{\hat{n}}}\right)$ found by this method together with the domain boundaries.

For 95% confidence intervals, when the sample is large $z_{\alpha} = 1.96 \approx 2$. Thus an interval of $2 \times$ standard error around the value of the domain boundary quoted gives some estimate of the expected variability. If the sample size is small then use of the 't' distribution will in fact give a wider interval. Further details on the sample sizes is given in table V.8 (Appendix V). It is interesting to note that the result for the simulator data: Dover Strait, Sector 3, has a large standard error attached to it, and the result of the hypothesis test did not indicate the presence of the domain. Also of interest is the fact that the values for the Sunk surveys all combined are less than the values for all exercises in the simulator data combined. This was to be expected as there is more variation among the types of exercises than among the surveys.

There are obviously various sources of error in this approach; viz. the underlying assumption, the estimation of σ , and the estimation of n since both x_C and x_A are estimated distances. Thus it is felt that considerable reliance cannot be put on these standard errors but they do at least provide an approximation to the degree of variability present. Very much more data is needed for this whole concept to be investigated further.

| Simulator Data | N.Miles | | | | | |
|--------------------------------|-----------------|----------------|-----------------|----------------|-----------------|----------------|
| | SECTOR 1 | | SECTOR 2 | | SECTOR 3 | |
| | Domain Boundary | Standard Error | Domain Boundary | Standard Error | Domain Boundary | Standard Error |
| All Exercises | 1.33 | .056 | 0.78 | .093 | 0.45 | .062 |
| Dover Strait 18,19,20 | 0.82 | .078 | 0.77 | .061 | 0.10 | .207 |
| Gibraltar 9,10,11,12,13 | 1.49 | .059 | 1.40 | .064 | 0.57 | .078 |
| Open Ocean 1,2,3,5,6,7,8,16 | 2.35 | .049 | 2.35 | .080 | 0.85 | .122 |

Notes (see p. 321)

| Sunk Data | SECTOR 1 | | SECTOR 2 | | SECTOR 3 | |
|-------------|-----------------|----------------|-----------------|----------------|-----------------|----------------|
| | Domain Boundary | Standard Error | Domain Boundary | Standard Error | Domain Boundary | Standard Error |
| All Surveys | 0.85 | .045 | 0.70 | .045 | 0.45 | .055 |
| Survey 1 | 0.47 | .062 | 0.50 | .072 | 0.35 | .043 |
| Survey 2 | 0.87 | .072 | 0.91 | .063 | 0.78 | .057 |
| Survey 3 | 0.71 | .088 | 0.58 | .069 | 0.45 | .031 |

Notes (see p. 321)

TABLE 5.18 The Standard Errors of the Domain Boundary in Nautical Miles under Different Conditions

A: Simulator Data by Sector and by Type of Sea Area
 B: Sunk Data by Sector and by Survey

SUMMARY

In this chapter the important questions of how to define the domain and then how to evaluate it have been considered.

The various definitions for the domange looked at were:

- (1) the minimum distance ships approach each other,
- (2) various percentiles of the distribution of separation between ships,
- (3) the distance from the central ship at which the density was locally maximised because of the displacement of the near ships,
- (4) the distance from the central ship at which the observed density level first reaches the overall density level.

The conclusion reached is that the last of these definitions is the most suitable.

The methods of evaluation then considered were:

- (1) a purely graphical approach,
- (2) an analytical approach involving assumptions as to the algebraic equation of the displacement curve.
- (3) The method of displaced numbers, whereby the end of the displacement process is located numerically and the domain boundary is then read from a graph.
- (4) The slope method, whereby different estimates of the slope of the line of uniform density are calculated, so that this can then be drawn and the domain boundary again read from a graph.

The third of these methods, the method of displaced numbers was considered to be the most useful with the existing data.

The final part of the chapter dealt with tests of hypotheses on the existence of a domain and the possibility of evaluating standard errors for the domain boundary.

The main importance of this chapter has been in the establishment of the techniques possibly rather than in the actual results obtained which are obviously affected by the quality and quantity of available data. The results quoted are for the most purely illustrative; a discussion of why they should differ from each other will be given in the following chapter.

In conclusion, however, it can be said that for the Dover Strait and Southern North Sea, areas of particular interest at the moment, the values for the domain boundaries (the domanges) are thought roughly to be about:-

0.8 n.miles - starboard bow (Sector 1)

0.7 n.miles - port bow (Sector 2)

0.5 n.miles - astern (Sector 3) *why*

CHAPTER 6

Independent Variables
Affecting the Size and Shape of a Ship Domain

INTRODUCTION

In the previous chapter, methods of evaluating the domanges were considered and as illustrations of the variety of procedures domanges were calculated under different circumstances. It was suggested in Chapter 2 when the general concept of a ship domain was discussed that there would be a variety of factors affecting the size and shape of the domain and an outline of them was given there. This chapter will now consider this aspect in more detail and look at the changes in the domain under different conditions.

The independent variables investigated and the source of data from which information on them could be obtained were as follows:-

- | | |
|---|--------------------------------|
| 1. Type of sea area | Simulator and Sunk survey data |
| 2. Relative velocity | Simulator and Sunk survey data |
| 3. Gross tonnage | Simulator and Sunk survey data |
| 4. Length of ship | Sunk survey data |
| 5. Maximum speed of ship | Simulator data |
| 6. Length of sea experience of the ship's navigator | Simulator data |
| 7. Fishing vessels as central ship | Sunk survey data |
| 8. The reaction of other ships to fishing vessels | Sunk survey data |
| 9. Buoys | Sunk survey data |
| 10. Restricted channels | Sunk survey data |
| 11. Traffic density | Sunk survey data |
| 12. Sectors around the central ship | Simulator and Sunk survey data |

The full results will be considered in this chapter but a summary of the main conclusions is given in the following chapter, p.185.

GENERAL METHOD

The first step was to obtain the appropriate distributions of numbers of ships for the particular values of the independent variable under examination. Thus if the gross tonnage of the central ship was being considered, the distribution of other ships by distance from all central ships of the same gross tonnage class was produced separately for each sector. This was then repeated for each of the gross tonnage divisions being considered. A selection of the programs used to produce the distributions for the different variables are given in Appendix VIII. For both Sunk survey and simulator data, the same exclusions as central ship were used as discussed in Chapter 4, except where specifically mentioned as otherwise.

The second stage was to establish whether there was any significant difference between the different distributions produced with the subdivisions of the independent variable or whether they were statistically similar. It was decided that the most suitable method was to use a non-parametric analysis of variance. The method chosen was the Kruskal-Wallis one-way analysis of variance by ranks discussed by Kruskal and Wallis (1952)⁽³⁰⁾ and Kruskal (1952)⁽³¹⁾, which enables one to decide whether K independent samples are from different populations. The classical parametric analysis of variance requires the original populations from which the samples have been drawn to be normally distributed and of equal variance, neither of which properties are necessarily fulfilled in this situation. Compared to a classical analysis of variance using an F-test which is the most powerful test, the Kruskal-Wallis test has asymptotic relative efficiency of $\frac{3}{\pi} = 95.5\%$ as shown by Andrews (1954)⁽³²⁾. It is thus only slightly less powerful than the classical test but is more efficient than most non-parametric tests. It is also much simpler to calculate than the classical method which was an advantage here with the repeated observations per cell of the distribution. A fuller discussion of the test is given in Appendix VI together with one of the situations fully worked to show the calculations. It was decided to use the distributions up to 2.5 nautical miles only, since the increase in noise after that point might start to confound the effects present. A discussion on the noise in the data can be found in Chapter 4, p.78. For each situation considered, only the value of the Kruskal-Wallis statistic and the corresponding critical value will be given in the text.

It was decided to consider the sectors separately still at this stage since it was considered likely that this might be one of the contributory factors to the effect of the independent variables. Thus the tests were performed on all the Sector 1 distributions under the different values of the independent variable, and then separately for all the Sector 2 distributions and finally the Sector 3 distributions. Differences between the sectors themselves will be considered in a separate section of the chapter.

The third phase was to calculate the appropriate values of the domange under the different groupings of the independent variable. The method developed in the previous chapter, termed the method of displaced numbers, was used, strengthening the conclusion that this really is the most suitable approach. Attempts to use the completely arbitrary method of taking the lowest decile of the distribution to 2.5 nautical miles again outlined the fact that this had little relationship to the complete picture that was present.

These three stages form the method which was used most generally in this set of investigations. Any occasional departure from this sequence will be discussed under the particular set of circumstances where it was appropriate.

Standard errors for the domanges will not be given since their sampling distributions have not been fully investigated. A few preliminary ideas were considered in Chapter 5, p.126, but an investigation in more depth is seen as one of the future extensions of the project.

TYPE OF SEA AREA

Results

The first circumstances to be investigated were the effects that the type of sea area had on the results for the domange. The simulator exercises fell into three separate sections, Open Ocean situations, Gibraltar Strait and Dover Strait situations, and these three were used as illustrations in the previous chapter, the results for the domanges being given in Table 5.14 .

Performing a Kruskal-Wallis analysis of variance on the distributions up to 2.5 nautical miles, the following test statistics are obtained:-

| | |
|----------|-------|
| Sector 1 | 24.93 |
| Sector 2 | 17.81 |
| Sector 3 | 8.65 |

The appropriate critical values for the given levels of significance are:

5% - 5.99; 1% - 9.21; .1% - 13.81.

Thus Sectors 1 and 2 can be described as very highly significant and Sector 3 as significant. This statement on its own is considered to be reasonable as it supports the argument for the difference between the sectors. Sectors 1 and 2 are the sectors for which the central ship has responsibility according to the collision regulations, whereas Sector 3 the astern sector is less critical for the central ship. Thus any adaptation to conditions is more likely to appear in Sector 1 foremost, then Sector 2 and to a lesser extent in Sector 3.

Fig. 6.1 gives the unsmoothed distributions up to 2.5 n.miles for each of the three sea areas, for Sector 2; the corresponding figures for Sectors 1 and 3 can be found in Appendix VI, p.294-5 Examination of these graphs together with the values found for the domanges, also shown on these figures, reveal a pattern which seems completely reasonable.

The distribution for the Dover Strait in Sector 1 begins to rise sooner than the other two, while that for the Open Ocean is such that the shape of the distribution is only just becoming apparent and in fact is mainly evident after 2.5 n.miles. The same is true in Sectors 2 and 3. The resulting values of the domange are such that those for the Dover Strait, the busiest sea area of the three are much smaller than those for Gibraltar, while those for the Open Ocean are largest of all, this of course being the area with maximum scope for manoeuvre. The third sector value for the Dover Strait is however considered to be a little unrealistic, and the fact that there is less difference between third sector distributions by area than in the other two sectors suggests that this might well be of the order of 0.50 n.m. as mentioned in the previous chapter.

For the following investigations using the simulator data, it was necessary to pool all the different areas as there was not really sufficient data to treat them separately. It is felt, however, that this very marked difference between the areas may well confound some

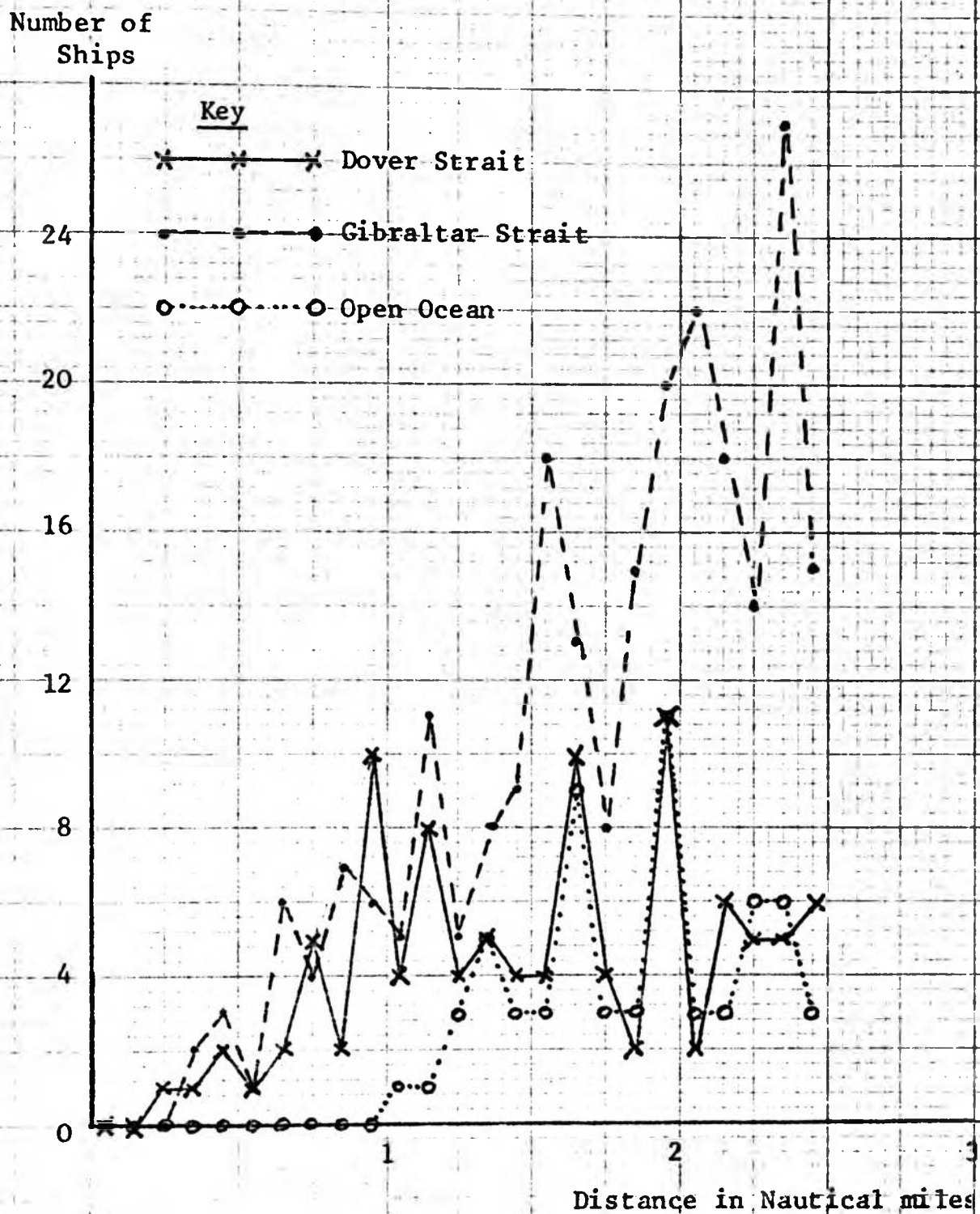

Notes (see p.322)

- Dover Strait Domange = 0.8 n.miles
- Gibraltar Strait Domange = 1.4 n.miles
- Open Ocean Domange = 2.4 n.miles

FIG. 6.1 Distribution of Ships Around a Central Ship by Area:
Sector 2: Simulator Data

of the other results making the pattern less clear. As the survey data was concentrated on one area it has however been possible to take account of this as will be shown later.

While still considering the factor of sea area it was felt that it would be interesting to compare the results for the Sunk area with the results for the Dover Strait. It was expected that the Sunk results might be larger than those for Dover because the area is less crowded, although the other main factor which was different was fog. The absence of fog in the Sunk surveys, it is suggested, would compress the domains from those which might have been seen in foggy conditions.

Since there were only two samples to be considered in each sector, it was decided to vary the analysis method and use another non parametric test, the Mann-Whitney test, which enables one to determine whether two samples can be considered as belonging to the same population. Although the sample sizes were very much larger in this situation than was frequently the case in the other analyses, so that the use of a parametric test based on the normal distribution might have been considered justifiable, it was decided wiser with this type of data to continue to use non-parametric tests. In any case the Mann-Whitney test has been shown to have an asymptotic relative efficiency of 95.5% (Mood (1954)⁽³³⁾) compared to the corresponding parametric test. A short description of the test is given in Appendix VI, together with the appropriate calculations.

If $x_{AiDover}$ and x_{AiSunk} denote the domanges for the i^{th} sector for ships in the Dover Strait sample and the Sunk survey sample respectively, and Z_i denotes the appropriate test statistic for the i^{th} sector, then the following results in n.miles are obtained

| | | | |
|----------|---------------------|--------------------|--------------|
| Sector 1 | $x_{A1Dover} = 0.8$ | $x_{A1Sunk} = 0.9$ | $z_1 = 2.00$ |
| Sector 2 | $x_{A2Dover} = 0.8$ | $x_{A2Sunk} = 0.7$ | $z_2 = 2.06$ |
| Sector 3 | $x_{A3Dover} = 0.1$ | $x_{A3Sunk} = 0.5$ | $z_3 = 1.77$ |

Using a two-tailed alternative hypothesis that the populations are not the same against a null hypothesis that they are, and a 5% level of significance with critical value 1.96, then it can be seen that the Sector 1 and Sector 2 results are just significant and the Sector 3 result is just not significant. Although the values of the domanges have not been directly compared they will vary in the same way with

the underlying distributions. Thus it seems reasonable to conclude that there is a slight difference between the Sector 1 and Sector 2 values, with the Dover Strait being smaller in each case. In Sector 3 however, there is quite probably no difference. This last result again gives evidence in line with the discussion on p.17.

Conclusions

The above discussion shows that there is an apparent difference between the dimensions of the domain in different sea areas. It would therefore be very useful to continue this study further by considering other areas at a later stage. The only other work which appears to have been done on a similar subject is that by the Japanese described on p. 94. However for reasons discussed on p.97 it was decided to adopt a rather different definition for the domain boundary so the results produced are not directly comparable. The only comparison which can be made is using the results quoted in Table 5.7 for Sunk Survey 2, obtained using a definition similar to the Japanese definition. The values for the domange are given as Sector 1: 2.45 n.miles, Sector 2: 1.95 n.miles and Sector 3: 1.25 n.miles. The results quoted from the Japanese work on p.23 give a half ellipse with semiaxis major of 1640 ft and semiaxis minor of 980 ft for ships between 200 and 500 feet in length. If the domange in Sector 3 is considered to be equivalent to the semiaxis major of the ellipse then the comparable figure for the Sunk survey is 7595 ft. Since the Sunk survey had only half of its identified ships between the lengths in the Japanese survey (see Table 3.6) the nature of ships in the two areas is obviously rather different. However as the Japanese area is apparently much busier, the two results would appear to be of the correspondingly right order.

It is obviously apparent that there is a great deal more that must be done on this aspect of the work. It is also suggested that it would be appropriate to investigate the size of domain in a particular area if the concept is to be applied to any problem specific to that area. If used in a completely different area, the results given in this thesis would only give approximate values.

The next series of factors to be considered will be those specific to one ship.

RELATIVE VELOCITY

It would be useful to determine the nature of any relationship that might exist between the size and shape of the domain and the relative velocity of other ships with respect to the central ship, since in any encounter situation this is an important factor. A navigator will always base his manoeuvring decision on an estimate of the relative velocity of another ship with respect to his own as well as on the relative positions. In fact it is common practice to plot an approaching ship at six minute intervals on a radar screen to enable an easy estimate of the relative velocity to be made. In situations where navigation is by radar because the visibility is so poor, this will be the only factor known about an approaching ship.

Starting with one central ship, at a certain time point and considering another ship in the vicinity at the same time, the relative velocity of the second ship with respect to the central ship was calculated, in addition to its relative bearing and distance. This was then repeated for all other ships, all other time points and all other central ships. The basic distance distributions by sector were then split down into various sub-distributions. For simplicity's sake in this analysis, it was decided to consider only the magnitude of the relative velocities, the relative speeds and ignore the direction at this stage. The relative speeds were considered in intervals of 5 knots, up to 20 knots and all higher speeds were included together. Thus separate distributions by sector were produced of the distance from the central ship of all ships whose relative speed with respect to the central ship was under 5 knots, and similarly for those with relative speeds of 5 knots and under 10, 10 knots and under 15, 15 knots and under 20, and over 20 knots. This analysis could be done for both the simulator and Sunk survey data and accounts of the information required to calculate the relative velocities for both situations are given in Chapter 5. The programs used to calculate the values and produce the distributions by speed range are given in Appendix VIII. It should also be emphasised that the relative velocities calculated were approximations to an instantaneous relative velocity, since they were only considered over six-minute time intervals. No attempt was made to produce an average value, which was considered inappropriate in this situation, but the actual value calculated would only have the accuracy of the measurements made.

Results

Performing the Kruskal-Wallis one way analysis of variance on the distributions of ships in each speed range separately for each sector in each of the two sets of data, the following values of the test statistic H were obtained.

Simulator data

| Sector 1 | Sector 2 | Sector 3 |
|----------|----------|----------|
| 7.04 | 6.11 | 4.71 |

Sunk Survey data

| Sector 1 | Sector 2 | Sector 3 |
|----------|----------|----------|
| 25.99 | 9.25 | 8.48 |

Since in each situation there were distributions for five speed ranges to be compared, the degrees of freedom were four and the 5% critical value from the χ^2 table was 9.49.

Thus the only significant result was in Sector 1 of the Sunk survey data and this value was in fact significant at the .1% level as well ($\chi^2_{4, .1\%} = 18.47$). Sectors 2 and 3 for the Sunk data were only just non-significant, and when the Sunk data was first analysed splitting the final speed group of 20 knots and over into two, 20 knots but under 25 and 25 knots and over, Sector 2 did produce a significant result. It is also interesting to note that the values of the test statistic H follow the same pattern for both the simulator and the Sunk survey data, with the most difference in Sector 1 and the least in Sector 3 in both cases. This pattern again illustrates the suggested hypothesis that, if there is a difference between the Sectors, Sector 1 is most susceptible to changes in relative speed while Sector 3 is the least affected.

Values of the damage were calculated for each of the different set of circumstances and the results are given in Table 6.1. The patterns of the distributions were not always very easy to interpret, particularly for the simulator data so it is felt that not a great deal of reliance should be placed on these results. It is considered that this problem in interpretation probably arises because of the interaction with other factors, such as the manoeuvrability of the centre ship. With the simulator data there is the continual problem of having all areas combined and it is very likely that this may be confusing any pattern with speed. For both the Sunk survey data and the Simulator

data the most difficult speed ranges to analyse were the smallest and the largest and this applied to all sectors. The numbers in brackets in Table 6.1 show the number of observations in each of the distributions by speed and sector. Examination of these suggests that for the Sunk data the interpretation difficulty in the largest speed range is caused by the comparatively small number of observations falling there. The difficulty in the smallest speed range might well indicate that the domange simply becomes more indeterminate at smaller relative velocities, since there is less anxiety with smaller speed differentials than with larger ones.

Using Table 6.1, two additional points of interest arise. The first is a comparison of the mean relative speed in the two situations. For the simulator data it is 13.0 knots and for the Sunk data it is 11.2 knots. Using a parametric test based on the normal distribution for the difference between two means, described in Appendix VI, it can be shown that the difference between these two means is very highly significant. The test is reasonable in this case since the samples are large and equal population variances may be assumed and in any case the underlying speed distributions may be considered to be normal. Since the simulator data is all in foggy conditions when one would expect slower relative speeds, this large significant difference must arise because of the open ocean exercises where there are a large number of head-on encounters, and hence higher relative velocities. It is however encouraging that the two means should be of roughly the same order.

The second point arises if weighted means are calculated of the domanges found by relative speed distribution, and compared with the overall results quoted in Chapter 5.

The following pattern emerges

| Simulator Data | Sector 1 | Sector 2 | Sector 3 |
|--------------------|----------|----------|----------|
| Actual domange | 1.3 | 0.8 | 0.5 |
| Mean speed domange | 1.1 | 0.9 | 0.6 |
| Sunk Data | Sector 1 | Sector 2 | Sector 3 |
| Actual domange | 0.9 | 0.7 | 0.5 |
| Mean speed domange | 0.9 | 0.8 | 0.6 |

| SIMULATOR DATA - ALL EXERCISES | | | |
|--------------------------------|-----------|-----------|-----------|
| Relative Speed in Knots | Sector 1 | Sector 2 | Sector 3 |
| Under 5 | 0.8 (44) | 1.0 (53) | 0.5 (35) |
| 5 But Under 10 | 1.1 (112) | 1.0 (114) | 0.9 (54) |
| 10 But Under 15 | 1.0 (89) | 0.8 (113) | 0.7 (74) |
| 15 But Under 20 | 1.1 (67) | 1.0 (61) | 0.4 (57) |
| 20 and Over | 1.5 (61) | 0.5 (68) | 0.6 (55) |
| SUNK SURVEY DATA - ALL SURVEYS | | | |
| Relative Speed in Knots | Sector 1 | Sector 2 | Sector 3 |
| Under 5 | 0.4 (79) | 1.0 (90) | 0.4 (142) |
| 5 But Under 10 | 0.8 (156) | 0.9 (161) | 0.9 (229) |
| 10 But Under 15 | 0.9 (130) | 0.7 (143) | 0.8 (195) |
| 15 But Under 20 | 1.2 (116) | 0.6 (104) | 0.3 (145) |
| 20 and Over | 1.6 (49) | 0.6 (40) | 0.5 (74) |

Notes (see p.322)

TABLE 6.1 Values of the Domange in Nautical Miles and the Sample Sizes for the Simulator and Sunk Survey Data by Relative Speed and by Sector

While it is not likely that domanges can be combined linearly in this manner, it does suggest that the results found are roughly of the right order.

Conclusions

Returning to Table 6.1, although it must again be stated that the actual results have an element of unreliability, it is possible to draw a few tentative conclusions. The major significant difference caused by relative speeds appears in Sector 1 of the Sunk data, and suggests an increasing domange as relative speed increases. The simulator data would also appear to agree with this pattern. Sector 2 seems to be much less affected by changes in relative speed and if anything, the pattern suggested is a decrease in dimensions with increase in relative speed. Sector 3 is even less affected and the pattern there is less clear. It would suggest a similar gradual decrease in dimensions as speed increases but this may not be very apparent. It could possibly be that the total sea area around the ship may not change very much with an increase in relative speed but that the shape of the domain does alter.

It is however apparent that a good deal more work needs to be done on this subject and more data is needed. The simulator data should then be analysed separately by area to see what interaction effect this does have.

With more data it would also be interesting to consider the direction of the relative velocity as well as the magnitude. It would seem necessary to look at the direction of the relative velocity within each sector to get a more complete picture of the processes at work.

Another related analysis would be to consider the domanges in terms of the speed of the central ship alone. This is however of less importance since it ignores the speeds of the other ships.

CHARACTERISTICS OF THE CENTRAL SHIP

It would seem a reasonable hypothesis that the size and shape of the domain will also be dependent on the type of central ship. This was investigated using two different variables for each set of data. For the simulator data, the gross tonnage of each own ship

was known, as was the maximum speed of the ships. For the Sunk data, information was available on gross tonnage and length for a certain proportion of ships and on broad type of ship for another section of the ships.

GROSS TONNAGE: SIMULATOR DATA

Table 3.2 (p. 37) gives the distribution of ships by gross tonnage used as own ships in the simulator exercises. It was mentioned there that this is probably a typical distribution of the size of ships which the students are accustomed to navigating but is not necessarily representative for the traffic in any one area. In particular it will not be representative for coastal waters where there will be many more smaller boats. This point is illustrated in Appendix VI where the distribution of own ships in the Dover Strait exercises is compared to the distributions of ships in areas at varying distances from the Kent coast observed in one of the National Physical Laboratory's surveys of the Dover Strait in 1971(10). In the main shipping lane, the distribution is much more representative than in the regions close to the coast. The inclusion of the target ships in any one area makes the traffic mix more representative so the behaviour of the ships should not be affected for this reason. However, the simulator data will only give results for larger ships.

The distributions of distance of other ships from the central ship by sector were prepared in seven different tonnage groups for the central ship. The first group consisted of ships whose tonnage was unknown so this was omitted from any further analysis as the ships in it could well have a variety of different tonnages and hence confuse the issue. This was however unlikely to introduce bias in any particular distribution. The six remaining groups were:-

4000 g.r.t. and under

5000 - 9000 g.r.t.

10000 g.r.t.

11000 - 18000 g.r.t.

20000 - 45000 g.r.t.

50000 - 100000 g.r.t.

The program is given in Appendix VIII .

Results

The values of the Kruskal-Wallis statistic were as follows:-

| | |
|----------|-------|
| Sector 1 | 9.03 |
| Sector 2 | 19.63 |
| Sector 3 | 64.86 |

Since there are 5 degrees of freedom, the appropriate critical value at the 5% level of significance is 11.07. Thus the Sector 1 value is not significant, but the Sector 2 value is highly significant and the Sector 3 value can be described as very highly significant.

Table 6.2 contains the values of the domanges which were calculated. Since the number of sample points were not always adequate to make the pattern completely clear some of the original groupings were combined. The sample sizes on which the values are based are also shown in Table 6.2. Even then it was not always easy to find the correct value, probably again due to the interaction effects of the other variables. In particular the first sector of the largest ships and the third sector of the smallest ships presented difficulty. It was also considered advisable to check for any possible bias in the representation of ship size by area, the analysis of which is contained in Appendix VI. The most significant feature was the inevitable predominance of ships of 10000 g.r.t. in the Open Ocean exercises since this was the standard size of ship for the opening exercises. However, it does not appear to have had much direct effect on the actual results.

At this point it is desirable to consider the results of the Sunk survey data on gross tonnage before attempting to draw any conclusions, about the relationships with the domain geometry.

GROSS TONNAGE: SUNK SURVEY DATA

The distribution of ships by tonnage and those identified by type alone in the Sunk surveys was given in Table 3.5, when the actual surveys were described. It was decided to use a fairly simple method of analysis and to divide the ships into nine mutually exclusive categories as central ship. These were:-

1. Under 400 g.r.t.
2. 400 but under 500 g.r.t.
3. 500 but under 2000 g.r.t.
4. 2000 but under 5000 g.r.t.
5. 5000 but under 10000 g.r.t.

| SIMULATOR DATA - ALL EXERCISES | | | |
|--------------------------------|----------------------------------|----------------------|----------------------------------|
| Gross Tonnage | Sector 1 | Sector 2 | Sector 3 |
| Less than 10000 g.r.t. | 0.8 ₍₁₀₁₎ | 0.8 ₍₁₀₆₎ | 0.1 [*] ₍₆₄₎ |
| 10000 g.r.t. | 1.1 ₍₉₇₎ | 1.1 ₍₁₂₀₎ | 0.2 ₍₇₅₎ |
| 11000 - 45000 g.r.t. | 1.3 ₍₁₀₂₎ | 1.1 ₍₁₁₂₎ | 0.5 ₍₅₄₎ |
| 50000 - 100000 g.r.t. | 0.6 [*] ₍₆₆₎ | 0.7 ₍₅₁₎ | 0.6 ₍₆₇₎ |
| All sizes | 1.3 ₍₃₇₃₎ | 0.8 ₍₄₀₉₎ | 0.5 ₍₂₇₅₎ |

Notes (see p. 322)

* Estimated

TABLE 6.2 Values of the Damage in Nautical Miles and the Sample Sizes for the Simulator Data by Gross Tonnage and by Sector

6. 10000 g.r.t. and over
7. Ferries
8. Fishing boats
9. Ships completely unidentified.

This meant that there were some ferries which had been completely identified, included in the tonnage category but not in the class of ferries, which consisted of those identified by type alone. The smallest category, of under 400 g.r.t. included five yachts, but there were insufficient of them to make any real difference, especially as they were visible for such a short time compared to the ordinary ships. Apart from the inclusion of fishing boats as one category of central ship, the exclusions for the central ship were the same as for the basic program described on page 76. The program used to produce the distributions of distance of other ships for each of the categories of central ship by sector is given in Appendix VIII.

RESULTS

It was decided to carry out the analysis of variance, in two ways, first using all nine categories, and secondly omitting the fishing boats and the unidentified ships. The second set of calculations were done because they provided a better comparison for size since fishing boats were expected to behave in a different fashion from other ships and the unidentified category might well have contained a variety of sizes which could confuse the issue. However, there might have been a bias towards the smaller ships and in any case the category was rather large so it could not be ignored altogether.

Taking all nine categories, the values of the Kruskal-Wallis statistic were as follows:

| | |
|----------|-------|
| Sector 1 | 28.80 |
| Sector 2 | 13.76 |
| Sector 3 | 25.11 |

On this occasion there were eight degrees of freedom giving a critical value of 15.51 at the 5% level of significance. Other critical values were 20.09 (1%) and 26.12 (.1%). This suggests therefore that there is a very highly significant difference in Sector 1, and almost similarly in Sector 3, but Sector 2 shows a value which is just not significant.

| SUNK SURVEY DATA - ALL SURVEYS | | | |
|----------------------------------|------------|-----------|------------|
| Gross Tonnage | Sector 1 | Sector 2 | Sector 3 |
| Less than 400 g.r.t. | 0.7 (57) | 0.6 (60) | 0.3 } (95) |
| 400 but less than 500 g.r.t. | 0.8 } (54) | 0.6 (54) | } (85) |
| 500 but less than 5000 g.r.t. | (41) | 0.7 (48) | 0.6 (97) |
| 5000 g.r.t. or more | 0.8 (48) | 0.9 (30) | 0.8 (85) |
| Ferrys | 0.9 (40) | 0.3 (44) | 0.6 (36) |
| Ships not Identified | 0.7 (290) | 0.7 (302) | 0.5 (407) |
| All Ships | 0.9 (530) | 0.7 (538) | 0.5 (785) |

Notes (see p. 322)

TABLE 6.3 Values of the Domange in Nautical Miles and the Sample Sizes for the Sunk Survey Data by Gross Tonnage and by Sector

Omitting the two categories described above, the recalculated values of the Kruskal-Wallis statistic were:-

| | |
|----------|-------|
| Sector 1 | 21.89 |
| Sector 2 | 5.28 |
| Sector 3 | 16.02 |

These must be compared with the 5% critical value on 6 degrees of freedom which is 12.59. The pattern is not altered considerably except that the Sector 2 value is now definitely not significant.

The behaviour of fishing vessels and that of other vessels towards them will be considered together in a later section of this chapter, but omitting those results, calculated values of the domange are given in Table 6.3 for the other classes. It also shows the number of points in each of the distributions up to 2.5 nautical miles of ships from the central ship.

It should be noted that although the overall identification rate was 28% for all ships fully identified using the number of ships as shown in Table 3.5, the overall percentage of number of points in the distributions up to 2.5 n.miles for all ships fully identified compared to the equivalent number for all ships is 40%. If one includes all ships identified by type, then the identification rate was 41% using number of ships, but in terms of numbers of points in the distributions the figure is 53% including fishing boats. The main reason for the increase is that only ships near the centre of the radar screen were included as central ships and as those identified all passed near the centre usually near the pilot vessel, a great proportion of their journey would be included except when within a mile of the pilot boat. Those unidentified were often very near the edge of the screen throughout their track.

The numbers in each of the original classes chosen were however often insufficient to justify further calculation. The six original tonnage divisions were condensed to four and in two instances the distributions were combined to produce a clearer picture. Thus returning to Table 6.3, some of the results for the domanges have been bracketed together.

Conclusions

The most interesting factor to arise from these two analyses is the Sector 3 behaviour. Although the simulator result would seem to be abnormally high, the fact remains that there is a significant difference in Sector 3 between the different size distributions for both the Sunk and the simulator data, yet this is the sector where normally the least difference, if any, appears. It is considered that this could well be a feature of the reaction of other ships to the size of the central ship rather than the reaction of the central ship to the other ships. Sector 3 was defined in terms of the collision regulations and represented the region where the central ship ceased to have direct responsibility. Looking at the results in Tables 6.2 and 6.3 it would suggest that there is a tendency for Sector 3 to increase with increase in ship size.

The actual values obtained for the simulator and Sunk data are evidently not directly comparable because of the variety of other factors at work but the pattern does seem to be compatible.

The results for Sector 1 and 2 are at variance, in that for the simulator data, Sector 2 shows a significant difference between the size classes and for the Sunk data it is only present in Sector 1. Again it is felt that the Sunk data is the more suitable of the two at this stage because it is related to one area. However, examination of the results would suggest that in both sectors there may be a gradual increase in the size of the domain as the size of the ship increases. The only exception from this pattern is the case of very large ships in the simulator exercises. The reduced size of the domains for Sectors 1 and 2 seem to indicate that ships of this size because of their limited manoeuvrability may take a passive role in avoiding collisions with ships in those sectors as well as with ships in Sector 3. The similarity of the domains for all three sectors, for this class of ship, lends support to this argument. One possible interaction effect with the type of area is that there is a certain limit beyond which the size of the domain cannot grow. This additionally might explain the differences between the two sets of data.

The result for the category 'Ferrys' is also rather interesting as the relationship between the Sector 1 and Sector 2 values seem to support the conclusions reached in the relative velocity discussions.

The ferrys passing through the area had some of the highest speeds, and as a result they seem to have a large Sector 1 damage against a small Sector 2 damage.

There is a great deal of work that must still be done on this aspect of the topic. More data is needed, particularly to examine the interdependence of ship size and area. However, from the limited amount available, it has been possible to suggest a tentative connection between the size of ship and the shape of the domain.

LENGTH BETWEEN PERPENDICULARS: Sunk Data

An alternative method of establishing a relationship between the dimensions of a domain and the size of the ship would be to measure the length of the ship. The length between perpendiculars was chosen and the distribution of ships in the Sunk survey by length was shown in Table 3.6. Similar information was not collected for the simulator data as it would have involved some additional assumptions. It is felt, in any case that it was not necessary to compare the two sets of data on every variable once an initial correspondence has been established, since the main significance of this present chapter is to suggest future lines of investigation.

For the first steps of the analysis the lengths of the central ships were divided into six groups.

1. Ships whose length was not known, and which could not be identified by type either.
2. Ships of length between 100 and 200 feet.
3. Length between 200 and 300 feet.
4. Length between 300 and 400 feet.
5. Length between 400 and 500 feet.
6. Length between 500 and 800 feet (largest recorded).

Distributions were prepared again for each length grouping of central ships using the program details of which are given in Appendix VIII.

Results

Since the first category was again rather indeterminate but of a rather large size, the analysis of variance was carried out, first of all including it but then excluding it.

| SUNK SURVEY DATA - ALL SURVEYS | | | |
|---------------------------------------|-----------|-----------|-----------|
| Length Between Perpendiculars Feet | Sector 1 | Sector 2 | Sector 3 |
| 100 ft. but less than 200 ft. | 0.7 (78) | 0.6 (79) | 0.5 (90) |
| 200 ft. but less than 300 ft. | 0.9 (24) | 0.6 (34) | 0.6 (70) |
| 300 ft. but less than 400 ft. | 1.2 (30) | 0.7 (32) | 0.6 (57) |
| 400 ft. and more | 0.8 (43) | 0.7 (30) | 0.7 (81) |
| Ships not Identified | 0.7 (290) | 0.7 (302) | 0.5 (407) |
| All Ships | 0.9 (530) | 0.7 (538) | 0.5 (785) |

Notes (see p.322)

TABLE 6.4 Values of the Domange in Nautical Miles
and the Sample Sizes for the Sunk Survey
Data by Length and by Sector

The following values of the Kruskal-Wallis statistic were obtained when the first category was included and the equivalent results when it was excluded are shown in brackets.

| | | |
|----------|-------|---------|
| Sector 1 | 13.23 | (15.21) |
| Sector 2 | 5.12 | (3.12) |
| Sector 3 | 14.83 | (3.97) |

The critical values at the 5% level are 11.07 and 9.49 on 5 and 4 degrees of freedom respectively. This pattern, not surprisingly, is very similar to that thrown up when the sub-distributions by gross tonnage were considered. Reference to Table 6.4 where the results for the domanges in each length-group are given show that the pattern is indeed confirmed. For the actual calculation of the domanges, ships that were identified by type alone were excluded from the category 'ships not identified' since the analysis by gross tonnage had shown these ships to be rather different with respect to domanges than the ships not identified at all. For consistency, these ships were also excluded in the calculation of the Kruskal-Wallis statistics. The figures for sample sizes also shown in Table 6.4 will therefore not be the same total as shown for all ships.

Conclusions

Unfortunately the categories of ships by length produced fairly small sample sizes, so although there will be little distortion of the results because of different area effects, the main problem with the simulator data, the results have limited reliability. However, the most interesting factor is again a tendency for there to be a limit to the amount that the Sector 1 domange can grow with size. These results thus lend support to the conclusions reached using gross tonnage as the independent variable.

From the limited amount of data it is difficult to say which size variable (length or gross tonnage) appears to be the most suitable. Fujii and Tanaka (1971)⁽²³⁾ however have established a linear relationship between the domain dimensions as defined by them and the length of ship. With further investigation it would be useful to determine which size variable is preferable for evaluating the domange.

MAXIMUM SPEED OF SHIPS: SIMULATOR DATA

Since the size of ships is related to their manoeuvrability, it was decided to consider another variable which was readily available for the simulator data, that of the maximum speed of the own ships.

For the analysis of variance it was decided to use only a few divisions of maximum speed viz:-

- 10 - 14 knots
- 15 knots
- 16 knots
- 17 knots and over
- Unknown

Thus sub-distributions of the distance of other ships were prepared by sector for central ships in each of the above categories. Details on the program are given in Appendix VIII.

Results

Comparing the different distributions for maximum speed changes within each sector by the Kruskal-Wallis analysis of variance, the following values of the test statistic were obtained. It was again decided to omit the category for ships with maximum speed unknown as it was not likely to be biased in any way.

| | |
|----------|-------|
| Sector 1 | 18.83 |
| Sector 2 | 2.38 |
| Sector 3 | 6.08 |

On this occasion there were 3 degrees of freedom so the 5% critical value was 7.81. It can be seen that only the Sector 1 result is significant. The corresponding values of the domanges and the numbers in the distributions on which they are based are given in Table 6.5.

Conclusions

Maximum speed is a less easily detectable characteristic than gross tonnage or length. Even in the simulator data where the size of the other ships cannot be actually seen, it would appear from the previous results that assessment of manoeuvring characteristics is still made in terms of size. The non-significant result in Sector 3 in this situation is thus not very surprising. It is of interest though that again the sector which shows most response is Sector 1.

| SIMULATOR DATA - ALL EXERCISES | | | |
|--------------------------------|----------------------|----------------------|----------------------|
| Maximum Speed in Knots | Sector 1 | Sector 2 | Sector 3 |
| 10-14 knots | 0.9 ₍₈₁₎ | 0.8 ₍₇₁₎ | 0.5 ₍₃₈₎ |
| 15 knots | 0.9 ₍₅₁₎ | 0.8 ₍₃₆₎ | 0.5 ₍₃₃₎ |
| 16 knots | 0.8 ₍₁₃₉₎ | 0.6 ₍₁₅₀₎ | 0.8 ₍₁₁₃₎ |
| 17 knots and over | 1.6 ₍₉₉₎ | 0.6 ₍₁₄₂₎ | 0.8 ₍₇₆₎ |
| All Ships | 1.3 ₍₃₇₃₎ | 0.8 ₍₄₀₉₎ | 0.5 ₍₂₇₅₎ |

Notes (see p.322)

TABLE 6.5 Values of the Domange in Nautical Miles and the Sample Sizes for the Simulator Data by Maximum Speed in Knots and by Sector

| SIMULATOR DATA - ALL EXERCISES | | | |
|--------------------------------|----------------------|----------------------|----------------------|
| Maximum Speed in Knots | Sector 1 | Sector 2 | Sector 3 |
| 10-14 knots | 0.9 ₍₈₁₎ | 0.8 ₍₇₁₎ | 0.5 ₍₃₈₎ |
| 15 knots | 0.9 ₍₅₁₎ | 0.8 ₍₃₆₎ | 0.5 ₍₃₃₎ |
| 16 knots | 0.8 ₍₁₃₉₎ | 0.6 ₍₁₅₀₎ | 0.8 ₍₁₁₃₎ |
| 17 knots and over | 1.6 ₍₉₉₎ | 0.6 ₍₁₄₂₎ | 0.8 ₍₇₆₎ |
| All Ships | 1.3 ₍₃₇₃₎ | 0.8 ₍₄₀₉₎ | 0.5 ₍₂₇₅₎ |

Notes (see p.322)

TABLE 6.5 Values of the Domange in Nautical Miles and the Sample Sizes for the Simulator Data by Maximum Speed in Knots and by Sector

The actual pattern of results for the damage is less easily interpretable because the values for the ships with the highest speeds seem rather high. There is however a correlation of .48 between the maximum speed of own ships in the simulator exercises and their gross tonnage. The analysis of this is given in Appendix VI, p.300. This correlation might therefore indicate a confounding of results due to the gross tonnage of the ship with that due to the maximum speed.

It would appear however from these results that, perhaps not surprisingly, the maximum speed of the ship is on its own not a very good predictor of a ship's behaviour. Under many conditions the majority of ships will be travelling at sub-maximum speeds so whatever the maximum may be they all have spare speed potential for manoeuvres, thus there is no clear relationship between maximum speed and damage size.

LENGTH OF SEA EXPERIENCE OF THE SHIP'S NAVIGATOR: Simulator Data

In the discussion in Chapter 2 on the types of independent variables which might affect the size and shape of the domain, they were considered under three categories, viz:- psychological factors, physical factors specific to one ship and physical factors general to all ships in an area. The only psychological type factor which it was possible to study in this project was that of the length of sea experience of the ship's navigator. The experience-lengths of the navigators were divided into seven categories, as follows:-

unknown
6 - 8 years
9 - 11 years
12 - 14 years
15 - 19 years
20 - 26 years
and 27 - 41 years.

Distributions by sector of the positions of other ships were produced separately for each of the categories of experience of the navigator of the central ship.

Results

Performing the Kruskal-Wallis analysis of variance in a similar manner as for the other variables the following values of the test statistic were obtained.

| | |
|----------|---------------|
| Sector 1 | 19.02 (18.85) |
| Sector 2 | 7.35 (6.79) |
| Sector 3 | 8.54 (7.77) |

These values must be compared against a 5% critical value of 12.59 since there were 6 degrees of freedom. Sector 2 and 3 values can thus be seen to be easily non-significant but the Sector 1 value can be described as highly significant as the 1% critical value is 16.81.

Given in brackets afterwards are the values of the statistics omitting the first category of unknown experience. It is clear that the pattern has not changed, comparing them to the 5% critical value of 11.07 with 5 degrees of freedom.

As in the previous examples, values of the domanges have been calculated and are shown in Table 6.6 with the numbers on which the values were based shown for ease of reference next to them in the same table. No attempt was made to calculate values for the unknown category, since this obviously does not differ significantly from the others and additionally did not contain many values. It was also necessary to combine two of the other categories because of too few values.

Conclusions

It was decided to check that the samples were not biased with respect to any area, as this was such an important factor. The analysis is contained in Appendix VI, p.301, where it is shown that there does not appear to be any particular distortion of the data with respect to experience and area. However, it should not be forgotten again that the effect of the different areas may be confusing some of the results.

The two most relevant sectors here are Sector 1 and Sector 2, of which Sector 1 is again the sector where there really appears to be a difference. In both these sectors the pattern is similar for increasing experience. With the smallest experience group the dimensions are small but rise with the next group. There is then

| SIMULATOR DATA - ALL EXERCISES | | | |
|-----------------------------------|-----------|-----------|-----------|
| Length of Sea-Experience in Years | Sector 1 | Sector 2 | Sector 3 |
| 6 - 8 years | 0.6 (44) | 0.6 (67) | 0.6 (37) |
| 9 - 11 years | 1.0 (96) | 0.8 (102) | 0.5 (88) |
| 12 - 19 years | 0.9 (63) | 0.7 (48) | 0.7 (28) |
| 20 - 26 years | 0.7 (56) | 0.5 (65) | 0.8 (54) |
| 27 - 41 years | 1.0 (100) | 1.0 (108) | 0.9 (60) |
| All Ships | 1.3 (373) | 0.8 (409) | 0.5 (275) |

Notes (see p. 322)

TABLE 6.6 Values of the Domange in Nautical Miles and the Sample Sizes for the Simulator Data by Length of Sea-Experience and by Sector

a decrease of dimensions with increase in experience, but again the final group of most experienced people show an increase in dimensions.

Following the work of Kemp (1974)⁽⁶⁾ discussed in Chapter 2, it was expected that a decrease in dimensions would accompany an increase in experience. It is quite possible that this pattern has not been completely picked up here because of the interaction of other factors. His work, on the other hand, involved navigators in exactly similar ships and exactly similar collision circumstances. It is clear therefore that more data is needed for this analysis so that it is possible to consider experience-length within each particular sea area.

The final sections of this chapter will consider the effect on a domain in the different circumstances which could be observed in the Sunk traffic surveys.

FISHING VESSELS: SUNK DATA

It was suggested in the discussion in Chapter 2 that there will probably be a difference in the behaviour of fishing vessels and in the behaviour of other ships to the fishing vessels. Since there were a certain number of fishing vessels observed in the Sunk surveys, an attempt was made to investigate two aspects of this problem:-

1. the behaviour of fishing boats as central ship to all other ships including other fishing boats;
2. the behaviour of other ships to fishing boats.

It was considered that there was insufficient data to examine exclusively the behaviour of fishing boats towards other fishing boats alone.

Fishing Vessels as Central Ship: Results

The first steps in this analysis were to compare the distributions of other ships around the central ship when fishing boats were central ship and when any other boat apart from a fishing boat was central ship. This analysis is given in detail in Appendix VI where it can be seen that Sectors 1 and 3 differ significantly but Sector 2 is non-significant. This result is very much in line with the results obtained generally when the type of ship was considered, Sectors 1 and 3 being the sectors where differences arise and Sector 2 not altering much.

In Sectors 1 and 3 the means of the distributions with the fishing boats as central ships were lower than those for other ships suggesting that there is a willingness for fishing boats to approach closer than for ordinary ships. Some of the difference is also attributable probably to the fact that the fishing boats were often together. This suggestion is supported when attempts are made to evaluate the domanges. Fig 6.2 shows the graphical representation of the distribution in Sector 1 and there appear to be two separate patterns, one possibly for other fishing vessels and the other for other ships. This double pattern was discernible in the other sectors. Thus the following values which can be read off are probably applicable to other fishing boats only. They are:-

Sector 1: 0.3 n.miles
Sector 2: 0.1 n.miles
Sector 3: 0.1 n.miles

cf fig 6.2:
0.75 n.miles

Fishing Vessels around Other Ships: Results

Comparing the distributions around a central ship which was not a fishing vessel, of (a) fishing vessels alone and (b) all ships other than fishing vessels there is no significant difference between them. Full details of this are given in Appendix VI page 302.

The tendency in Sector 1 and Sector 3 is for the means of the distributions with respect to fishing vessels to be greater than those for the distributions with respect to all other ships. The difference however is not significant. Unfortunately, this analysis is based on very small samples compared to the other distributions as there are only 135 points in total representing fishing vessels within 2.5 n.miles of the central ship. This also made it difficult to evaluate domanges in each of the sectors. Estimated values are:-

Sector 1 1.1 n.miles
Sector 2 1.0 n.miles
Sector 3 0.9 n.miles

Fishing Vessels: Conclusions

From the above discussions, it is clear that the fishing vessel results have not produced very certain conclusions, and much more evidence is needed on this.

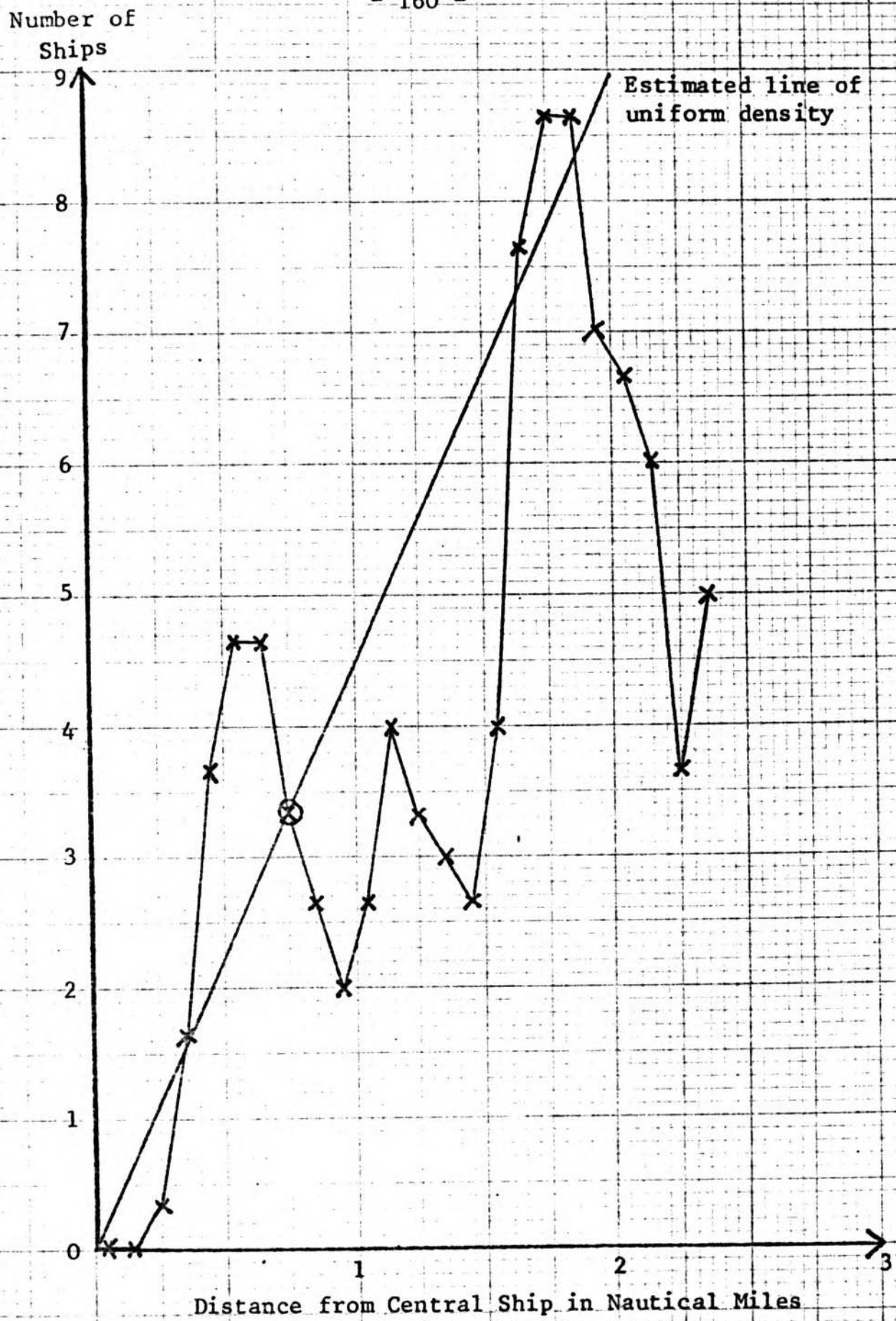

Notes (see p. 322)

FIG. 6.2 The Distribution of Ships Around a Fishing Vessel
Sector 1: All Sunk Surveys

Very tentatively it can be suggested that firstly, fishing vessels accept very small domains when surrounded by other fishing vessels. Secondly, other ships tend to keep slightly further away from fishing vessels than they do from 'ordinary' ships navigating through an area. It is very likely that these results will in any case be dependent on the particular area just as the general results are. It is therefore suggested that this should be studied carefully in any area where there is a high proportion of fishing vessels, if it is required to apply the concept of ship domains there.

BUOYS: SUNK SURVEY DATA

Fujii and Tanaka (1971)⁽²³⁾ quote values for the dimensions of the domain of an obstacle, in terms of the average length of the ships passing. Their findings suggest much smaller domains than for ships. It was therefore decided to consider this, using the concepts developed in the thesis on the Sunk survey data.

Fig. 6.3 shows the positions of the ten stationary objects which were sufficiently plain in the radar pictures. Of these ten objects, one was the Rough Tower, an old wartime fort surrounded by two buoys, but treated as one object in this analysis; a second was the Sunk lightvessel and the other eight were buoys. Comparison of this figure with Fig.3.9 shows that there were also a collection of buoys to the north-east of the Rough Tower marking the channel into Harwich. These were however omitted as it was not always possible to distinguish between them clearly. The behaviour of ships in the channel will however be considered after this.

The positions of the buoys were read in Cartesian coordinates and using a special program, the positions of all the buoys with respect to one ship could be calculated. This was then repeated for all ships and all time points and hence a similar set of distributions by sector were produced as for the situation with other ships. Details of the program used are given in Appendix VIII. For this investigation two separate runs were made, one with no exclusions and the second excluding the ships normally excluded as central ship in the analyses.

Results

The values of the domains obtained under each of the two sets of circumstances together with the numbers on which they are based, are

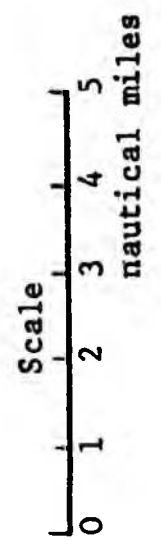
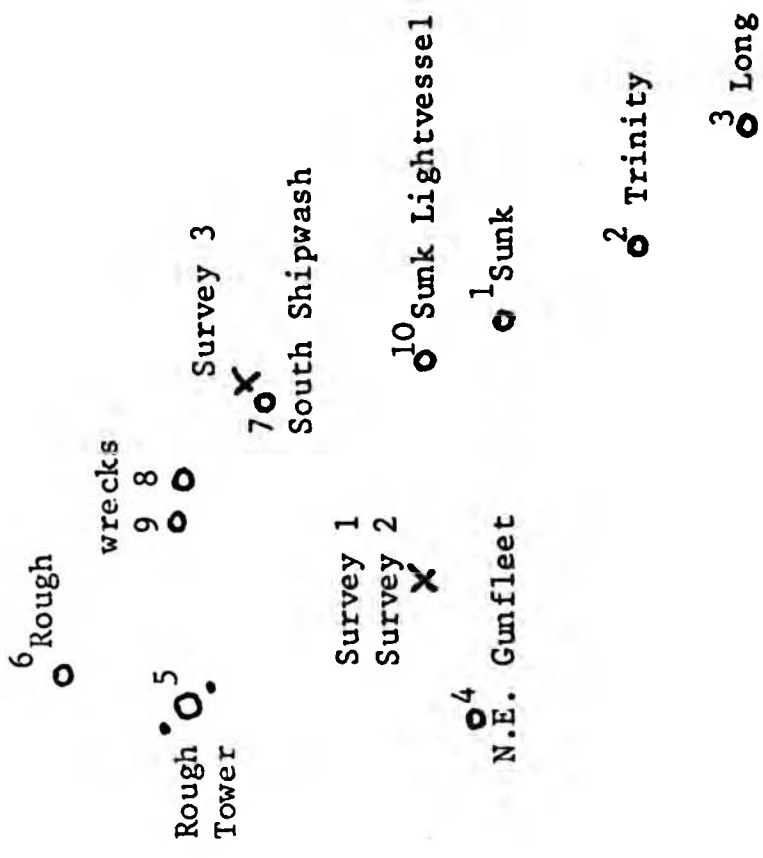
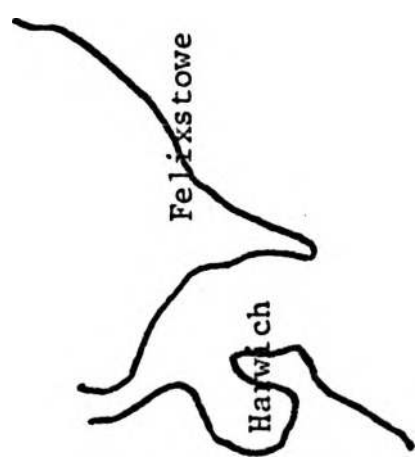
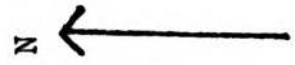

FIG. 6.3 Sketch Map of the Survey Area Showing the Positions of the Buoys Included in the Analyses

| SUNK SURVEY DATA - ALL SURVEYS | | | |
|--|-----------|-----------|-----------|
| Distributions With Respect to Buoys Based on:- | Sector 1 | Sector 2 | Sector 3 |
| All Ships as Central Ship | 0.5 (223) | 0.1 (249) | 0.1 (305) |
| Selected Ships as Central Ship | 0.7 (45) | 0.7 (64) | 0.6 (60) |
| Distribution with Respect to Other Ships | 0.9 (530) | 0.7 (538) | 0.5 (785) |

Notes (see p.322)

TABLE 6.7 Values of the Domange in Nautical Miles and the Sample Sizes for the Sunk Survey Data by Reference to Buoys and by Sector

presented in Table 6.7. The most immediately striking fact is that the values for no exclusions are very much smaller than in the other case. In fact a very crude test on the distributions on which they are based shows that the distributions are significantly different. Full details can again be found in Appendix VI. It is however, suggested that the values obtained when no exclusions are made, are in fact the more interesting values. By introducing the exclusions, only ships navigating generally through the area are considered and they may be nowhere near the buoys in any case. However, these values are very similar to the values obtained for the domain boundaries with respect to other ships. When no exclusions are considered the most important category of ships to be included in this context are those in the vicinity of the pilot boat and the pilot boat itself. As the pilot boat was always close to the Sunk lightvessel and the Sunk buoy, ships in this neighbourhood must have had to consider how close they approached the buoys in addition to their distance from each other. It is therefore suggested that the values obtained in this case are the values appropriate to a situation where navigation must be close to the buoy, and the values obtained with the exclusions are the values appropriate to a situation where there is no need to be near to a buoy.

If this reasoning is correct then the values would appear to agree with the Japanese results mentioned above. It should however be investigated further when more data is available to check that the smaller results are not too dependent on the lower speeds which must be present in the neighbourhood of the pilot vessel.

CHANNEL: SUNK SURVEY DATA

Reference to Fig. 3.9 , p.41 shows that in the north-west corner of the Sunk survey area the approaches to Harwich and Felixstowe are along a buoyed channel. At its narrowest point the channel is just under $\frac{1}{2}$ mile wide, although it is reasonably variable throughout its length. It was decided therefore to investigate the movement of ships in this region, although being to one side of the screen the definition was not always very good. For this analysis, the only ships included were those actually in the area defined as the channel as described on p. . This applied to both central ships and the other ships in their distribution around the central ship.

Results

The values obtained for the domanges were as follows:-

| | |
|----------|-------------|
| Sector 1 | 0.4 n.miles |
| Sector 2 | 0.4 n.miles |
| Sector 3 | 0.4 n.miles |

No attempt has been made to draw further conclusions from this data for various reasons. Firstly, the sample sizes on which they are based are again not very large viz:- Sector 1: 48, Sector 2: 52, Sector 3: 60. Secondly, because the channel was variable in width the results obtained must represent an average value over the whole channel. It is evident that these results could not be applicable to the narrowest point of the channel when two ships are exactly beam on. Thirdly, the analysis developed in this thesis should probably be adapted for a channel situation. For normal navigation the ship has equal freedom in two dimensions, so it is reasonable to define sectors around a ship. However, in the channel the freedom in one direction is restricted by the width of the channel. It might therefore be sensible to subdivide the sectors further and consider the situation separately within each one. Any future analysis on these lines should also consider different widths of channel to see if any simple relationship can be found between the dimensions of the domain and the width of the channel.

For this present thesis these approximate values for the domange in a channel must be considered therefore as simply further evidence of the existence of a domain and the hypothesis that it will vary under different conditions.

DENSITY OF TRAFFIC: Sunk Data

The third variable which was present in the Sunk surveys was the density of traffic. It was decided to measure this indirectly by counting the number of ships within five miles of each other at each six-minute time point. This information was collected using the same definitions as for the basic distributions of ships around the central ship. Thus for each time point, the number of ships within 5 miles of each permissible central ship was counted. An overall mean was calculated for each of the three surveys and were as follows:-

Survey 1: 20.8
Survey 2: 7.5
Survey 3: 11.3

These figures measure the mean number of encounters of less than 5 miles per time point. There was considerable hourly variation as Fig. 6.4 attempts to show. This gives the hourly means as defined above for each of the three surveys. The most outstanding feature is the very high value of 62.1 obtained in Survey 1 for the hour 00.00 - 01.00. This was partly explained by a group of ships entering the area from the north-east corner within rapid succession of each other. In fact the pilot boat had to service five ships in just over half-an-hour whereas often there would only be two or three an hour or less requiring the pilot boat.

Survey 1 was the most variable of the surveys as the following standard deviations for the number of encounters per time point shows.

Survey 1: 25.4
Survey 2: 8.0
Survey 3: 11.3

Using this information it can be shown that all three means are significantly different from each other in pairs.

Number of
Points

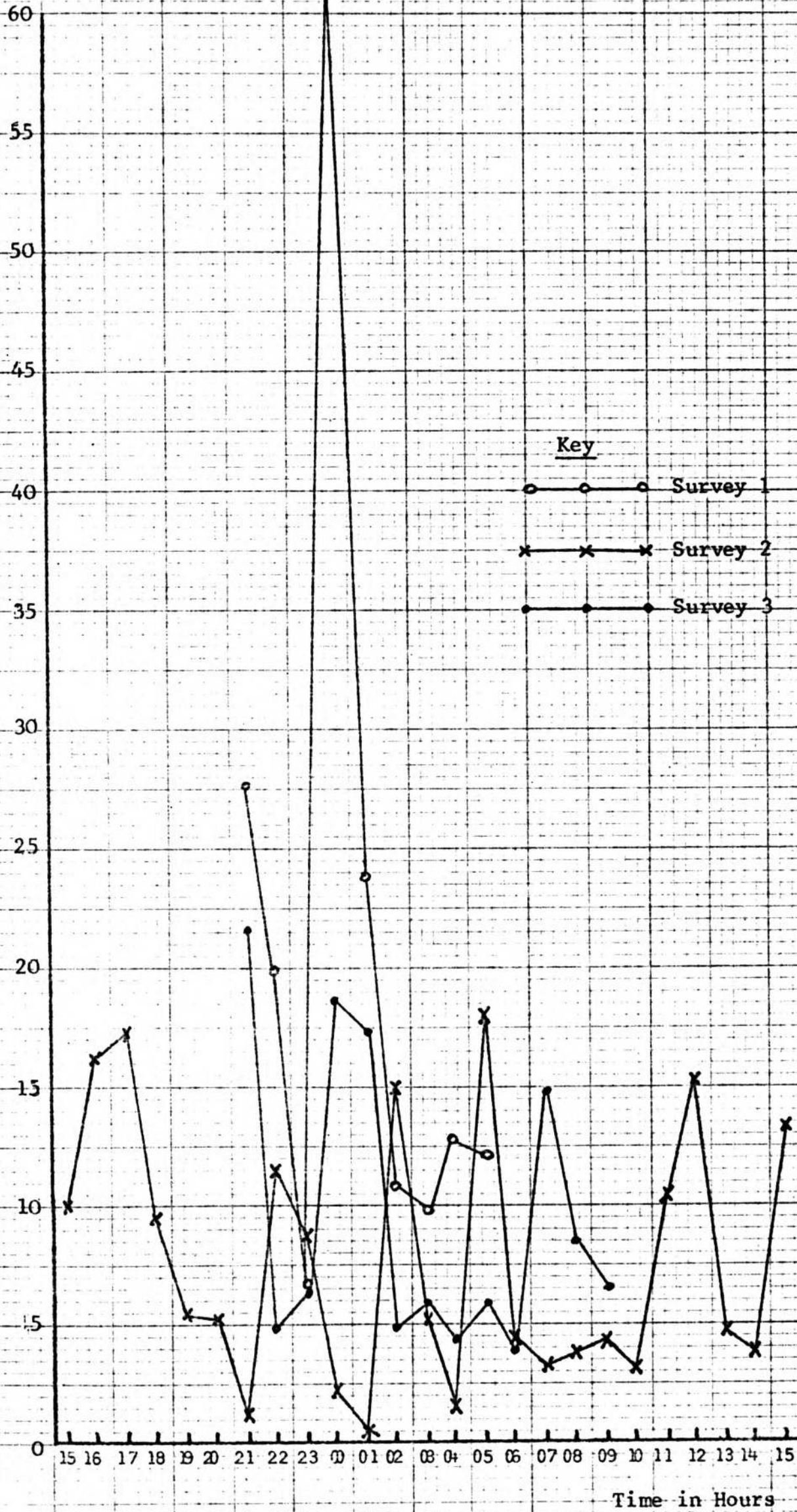

FIG. 6.4 Average Density of Points Per Hour by Survey
Sunk Survey Data

Results

Referring back to Table 5.14 p.120 where the values for the domanges were given by sector for each survey, it is interesting to note that for all three sectors, Survey 2 had the greatest values, Survey 1 the smallest values and Survey 3 lay in between. Since this is the reverse order for the mean density per survey it appears to support the hypothesis that the domange values will be inversely related to the density in the area. This is also consistent with the results obtained for the different areas in the simulator data.

The Kruskal-Wallis one-way analysis of variance was performed for each of the three sectors with the following results:-

Sector 1: 3.10

Sector 2: 0.16

Sector 3: 7.58

With 2 degrees of freedom the critical value for a 5% significance level is 5.99. Thus only in Sector 3 is the difference significant. The possible explanation is that for one particular area, there is an adjustment for density, but it is not very large. Since Sector 3 always contained the largest number of values in the Sunk survey data, any difference is most likely to show up there.

It is felt however that it is reasonable to conclude that the variety of results obtained for the three surveys can be accounted for by the variety in density. To actually derive the relationship between domain size and density, more detail is needed such as an analysis involving all points obtained at the same density level together.

SECTORS

The final topic to be considered in this chapter is the question of differences between the domanges in the three sectors. Although this is strictly of a different nature since there is not an independent variable involved as in the other topics in this chapter, it is one of the original hypotheses of the project and it seems most reasonable to consider it here.

The most interesting result is the way in which the different sectors respond to the different variables. Sector 1 was nearly always significantly different under different values of an independent

variable, whereas Sector 2 was very rarely so. Sector 3 showed a significant difference when the size of ship changed but for other variables it was unaffected mainly. Thus the effect of the different variables is to change the shape of the domain as well as the size. This is undoubtedly the most important factor making the analysis by each sector separately essential.

For any particular set of circumstances it is not always possible to detect a significant difference between the distributions for the three sectors using the Kruskal-Wallis analysis of variance on the distributions up to 2.5 nautical miles. However, taking as an example, the combined survey results for all the Sunk surveys, there is a significant difference between Sector 1 and Sectors 2 and 3 but not between Sector 2 and 3. From visual examination of the distributions, it is possible that the displacement patterns are in fact different between Sector 1, 2 and 3. Generally the Sector 1 patterns appear to be of a similar form, and the same is true for Sectors 2 and 3, which would explain why the use of a test based on a central point of a distribution does not necessarily show any significant difference between the three sectors. It also suggests that if any future work is done on the algebraic forms of the displacement curves it may be necessary to note a slightly different form for each sector.

SUMMARY

In this chapter the dependence of the size and shape of the domain on a variety of independent variables has been examined. The variables considered come under the broad headings of size and type of vessel, relative speed of vessel, sea-experience of the navigator and type and characteristics of the area of navigation.

In the light of these findings the possible uses that can be made of the concept of a ship domain will be considered in the next chapter.

CHAPTER 7

An Evaluation of the Project on Ship Domains

INTRODUCTION

The first part of this final chapter will consider possible applications of the concept of a ship domain. It is proposed for this thesis simply to indicate ways in which the ship domain relationships might be applied to practical problems. Thus any detailed work on these ideas is seen as an extension of the project at a later date. Throughout the earlier chapters of the thesis mention has been made of the topics which also require further study; it is therefore appropriate to summarise these thoughts in the second half of the chapter.

APPLICATIONS OF SHIP DOMAINS

EXTERNAL OVERALL CONTROL OF SEA TRAFFIC

GENERAL REMARKS

Discussions over the extent to which marine traffic should be subjected to external control of any sort have been fairly common over recent years. Even though it is a three-dimensional mode of transport air traffic has always had much more control exercised over it than marine traffic because of the speed at which aeroplanes can fly. Over the years a network of airways has been developed to avoid collisions between aircraft. Within these airways the air traffic control procedure has depended upon the maintenance of safe separation standards between aircraft. These standards were originally set largely by practical guesswork based on knowledge of pilots and airline operators on the standard errors of flights but are now determined by a minimisation of collision risk arising from flying errors as mentioned on p.17.

Van Hooff(1971)⁽³⁴⁾ suggests a marine traffic control system on similar lines to an air system, and maintained by local authorities. This would probably represent the most rigid type of control system, particularly if it were made mandatory.

At the moment the first steps towards the establishment of marine traffic control systems outside terminal areas and port approaches have already been taken with a mandatory routeing system in operation in the Dover Strait and in other areas. The next stage would be the setting up of shore based stations which could guide a ship through congested

areas such as the Dover Strait according to agreed separation standards. Before considering how the ship domain values could be used in determining these separation standards it should be noted that in some port areas some sophisticated schemes are already in operation, e.g. the Europoort scheme described by Schimmel (1971)⁽³⁵⁾.

Ship Separation Standards

First Method:

It will be recalled that a ship domain has been defined as the area around a ship which a navigator would like to keep clear of other traffic. Thus it could be assumed that when this area is completely clear the navigator is under minimum stress. Even if the boundaries are violated by other ships, although there is a danger threat there, the boundaries have in any case been set so as to minimise the collision risk. A quick visual examination of the data obtained in this study helps to clarify this point. By the definition used to obtain the domanges there was certain to be a relatively small number of points inside a domain so there were occasions when the danger threats were increased. However, as might be expected, an actual collision was never observed, so it is reasonable to conclude that the navigators themselves choose the size of domain to minimise collision risk. It therefore follows that the values for the domanges would provide suitable separation standards.

The most simple method of all would be to take a uniform separation distance for all ships. The effect of this would be to lose the distinction between the sectors. Since the results in the previous chapters support the hypothesis that Sector 1, the starboard bow sector, is the most important of the three sectors, as they were defined in Chapter 4, and in most areas has the largest dimensions anyhow, the domange for this sector should be used. Thus the domain, or separation zone around a ship, would become a circle with radius equal to the Sector 1 domange. This in itself was found to be variable from area to area so would need to be established for the appropriate control system. Thus in the Sunk area the separation distance could be 0.9 n.miles, in the Dover Strait area 0.8 n.miles, in the Gibraltar Strait 1.5 n.miles and in the open ocean, where there is most unlikely to be any external control anyway, 2.4 n.miles.

Second Method

This simple approach is very akin to the approach used in the air whereby single standards are set for a large number of aircraft. The assumption usually made is that aircraft on a given route can be considered as identical units all flying with the mean speed observed. Reich (1964)⁽²⁰⁾ when considering traffic in the North Atlantic Region quotes a mean observed speed of 480 knots so small variations will be negligible compared to this. In contrast, when dealing with shipping Draper and Bennett (1971)⁽²⁵⁾ in an analysis of speed distribution from an NPL Dover Strait survey, found larger variations in the speeds which meant that the speed distribution was fairly close to a normal distribution with mean 13 knots and standard deviation 4 knots. This implies that 95% of ships will have speeds between 5 knots and 21 knots roughly. Thus the assumption of uniform speed for marine traffic is less realistic.

The results of the previous chapter have also suggested that the domanges are affected by the speed of the ship and by its dimensions. A slightly more sophisticated approach therefore would be to set separation standards depending on the length or tonnage of the ship say. Once variation is introduced then the three sector boundaries can be reintroduced as well. Thus if one ship is following another, both travelling at the same speed, then the separation distance between them will be the maximum of the third sector domange of the first and the first sector domange of the second. This should lead to a more efficient use of sea space. It would also be fairly easy to monitor, if a ship reporting at the control station gave details on its size, since the separation distances to be applied to it could be programmed onto the radar display in a similar manner as height information is given on air traffic control schemes.

This second approach has been discussed in terms of the dimensions of the vessel rather than speed because speed could always be controlled as well if necessary. If the marine traffic control system was made very similar to the air system then Van Hooff suggests that ships would proceed along corridors and would have to seek permission before changing corridors. Thus speed would indirectly be controlled if the separation distances must be kept and there were no opportunity of changing corridors. In a less rigid system, ships could be allowed more freedom of action both in position and speed provided separation standards were not violated. It might also be possible to take into account the normal cruising speed

of a particular type of ship when setting separation standards, although no information has as yet been obtained on the relationship between domain size and size and speed of ship simultaneously.

Third Method

Another point which should be considered is the variations in ship behaviour at different times in the area. It has not been possible to consider the direct effect of weather conditions on the sizes of the domains but one of the original hypotheses was that they would vary inversely with the visibility distance. Thus it might be a good idea to establish further standards separately for good and poor visibility. It has however been possible to show that there appears to be a relationship between density and domain size, again reverse. Evidence on this came from three separate Sunk surveys and the three areas in the simulator data. If domains shrink under increased density conditions, it is difficult to decide when the increase in risk has reached an intolerable level. More work will probably be needed on the relationship between density and domain boundaries before this question can be finally settled. It could be that there is a definite limit to the amount the boundaries will shrink and hence this will be the true domain boundary. However what is more likely is that the speed of the vessel will change, thus altering the domain boundaries anyway. It may in the long run, be better to send ships through an area maintaining a certain speed level, with the appropriate domanges than to allow congestion with slower and slower speeds. Another alternative might be to take a survey of ships' navigators to see what minimum navigation separation standards they would be willing to accept.

As a simple solution for the present, without more detailed knowledge, it is suggested that average values could be calculated for an area and possibly only making adjustments for the size of ship. This really is the technique that has been used throughout this thesis, particularly for the Sunk data since all the results involving independent variables have been for all three surveys and hence for three different density levels combined.

Fourth Method

The fourth method is rather different from the others in that the separation standards would be calculated from the values for the domanges indirectly. The approach is similar to that used in air traffic studies

whereby the accuracy of navigation is taken into account, and the level of risk which is considered safe. Under this method the separation standards would not be set at the domain boundaries but a certain distance from them to minimise collision risks. The three sector shape would however still be retained.

Since it is unlikely that ships will navigate through an area with a constant 100% accuracy, there will be a probability of the domain boundaries being breached. However, on the sea as opposed to the air because of the very different speeds involved, there is still time for the ships to manoeuvre out of the situation so the overall probability of collision is the product of the probability of the domain boundaries being broken and the probability of ineffective collision avoidance action being subsequently taken by the personnel of the ship. This second probability is likely to be very small.

Establishment of Controls Over Entry into a Certain Area

While discussing the question of control, an alternative approach to having a shore-based guidance unit for the whole passage through an area would be to have a control unit over ships entering the area. Thus the actual navigation in the control area would be left entirely to the ship's personnel but restrictions would be put on the number of ships entering the area. Evidence analysed by the author (1972)⁽³⁶⁾ showed that the distribution of ships per hour passing through the Dover Strait could reasonably be assumed to fit a Poisson distribution, (see Appendix VII). Thus the arrival of ships at an entry point to the Dover Strait can be considered to be random. Evidence from various other parts of the world supports this. If the minimum acceptable values for the domain boundaries could be established as suggested in the earlier comments in this chapter, studies could be made of areas where these minimum values are likely to be encountered. If their probability of occurrence is too high, then some form of entry control should be imposed.

It is evident that the question of control will be discussed for a long time to come as there are a great many factors to be taken into account, of an economic, legal, social and technical nature. Even if a service were not introduced for all ships it might be suitable for certain ones, such as very large tankers, ships carrying dangerous cargoes and ships with limited manoeuvring capabilities. Whatever form it takes it is suggested that the ship domain concept will provide a useful basis for planning.

ENCOUNTER RATES

The previous discussion on separation standards suggested an alternative approach to this using an acceptable collision risk. This collision risk was defined as the probability of breaching separation standards multiplied by the probability of ineffective collision avoidance manoeuvres subsequently. It is clear however, that a similar analysis can be used for any area even if there are no specific separation standards in existence. Papers by Draper and Bennett(1972)⁽²⁵⁾ and Barratt (1973)⁽²⁴⁾ have considered the effectiveness of the Dover Strait routeing system using as an objective measure the encounter rate for ships. If it can be assumed that the probability of effective collision avoidance manoeuvres is constant for encounters along all possible relative approaches of two ships then a study of encounter rates gives a direct approach to likely collision rates.

Different authors suggest different forms for the encounter area. Stratton (1971)⁽³⁷⁾ in a general overview of some of the problems to be faced in navigation, suggests an encounter area which varies with relative velocity. May (1971)⁽³⁸⁾ in a paper on the related topic of near mid air collisions in free airspace suggests on the other hand a fixed encounter area. Both papers on the Dover Strait mentioned above have used this second idea. Draper and Bennett for instance considered the encounter area to be a circle around the ship firstly, with radius 1 nautical mile and secondly with radius $\frac{1}{2}$ nautical mile, both arbitrarily chosen distances.

It is now suggested that a ship domain should be used as the encounter area. An encounter can be said to have occurred if had no avoiding action been taken, one ship would have entered the domain of another.

The same remarks apply as given in the previous section because of the dependence of the domanges on a variety of variables. However, it is again suggested that the values obtained for an area using all the available data together are suitable values for the present, since they represent an average over the conditions observed. The degree of sophistication used will obviously depend on the study. Thus if the project is to be an observational one, it would be a relatively simple matter to count the number of encounters in a given area over a period of time by noting the number of evasive manoeuvres made. Each ship

could be given a three-sector domain with domanges corresponding to the relevant variables. Thus various variables such as relative velocity, size of ship and experience of navigator could readily be included. If however, the project is to be a theoretical one some simplifications are likely to be necessary unless a computer simulation approach is used. This will be returned to at a later point in the chapter.

Theoretical Models

1. A Circle

For an analytical approach it is often desirable to use a simple geometric figure as an approximation to a domain and assumptions must then be made. The simplest assumption would be to consider the encounter area as a circle but with radius given by Sector 1, as for a separation standard. Thus in the Dover Strait a value of 0.8 nautical miles should be taken.

2. An Ellipse with Major Axis in the Direction of the Ship's Head

A second assumption would be to take the domain to be an ellipse, similar to the Japanese studies but not necessarily for the ship to be at the centre. The dimensions of the ellipse could be derived from the appropriate domanges. If the Dover Straits are taken as an example, the values of the domanges in Sector 1 and Sector 3 are 0.8 and 0.5 n.miles respectively. Thus in Fig. 7.1 if S represents the centre of the ship

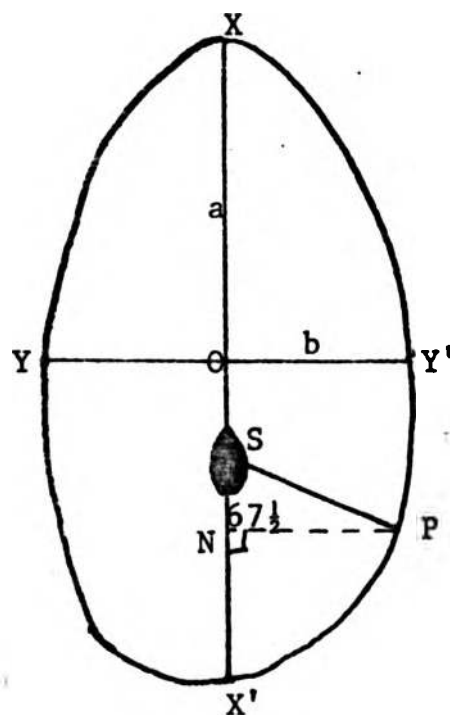

FIG. 7.1 An ellipse with major axis in the direction of the ship's head as a theoretical model for the ship's domain

$$XS + SX' = 0.8 + 0.5 = 1.3 \text{ n.miles.}$$

$$\therefore XO = 0.65 \text{ n.miles} = a \text{ (semi major axis)}$$

If PS represents the Sector 1/Sector 3 boundary

$$\angle X'PS = 67^\circ 30' \text{ and } PS = 0.5 \text{ n.miles}$$

\therefore if PN is perpendicular to OX'

$$PN = 0.5 \sin 67^\circ 30' = .46$$

$$SN = 0.5 \cos 67^\circ 30' = .19$$

$$\therefore ON = .19 + .15 = .34$$

But in parametric coordinates if a is the semi major axis and b is the semi-minor axis

$$ON = a \cos \theta \quad PN = b \sin \theta$$

Solving these equations gives

$$b = .63 \text{ n.miles}$$

Thus in this particular set of circumstances, it would seem reasonable to consider the domain as a circle with radius 0.65 n.miles but with the ship offset from the centre. This approximation will probably be suitable enough for most situations. Therefore it is suggested that a second approximation to the encounter area would be to consider a circle with radius the mean of the Sector 1 and the Sector 3 domanges. For the Sunk area, the radius would be 0.65 n.miles, as for the Dover Strait, but for the Gibraltar Strait it would be 1.05 n.miles and for the Open Ocean 1.6 n.miles.

3. An Ellipse with Major Axis Inclined to the Direction of the Ship's Head

A third analytical approximation to the domain shape for use as an encounter area would be to consider an ellipse with the ship off centre and the major axis at an angle to the fore and aft line of the ship. Fig. 7.2 gives a representation of this idea. It has the advantage that it takes account of differences which may be found between the sector one and sector two domanges.

To calculate the relevant parameters of the ellipse, a, b, the semi major and minor axis respectively and ϕ the angle between the major axis of the ellipse and the direction of the ship's head some further assumptions must be made. With reference to Fig. 7.2, a possible

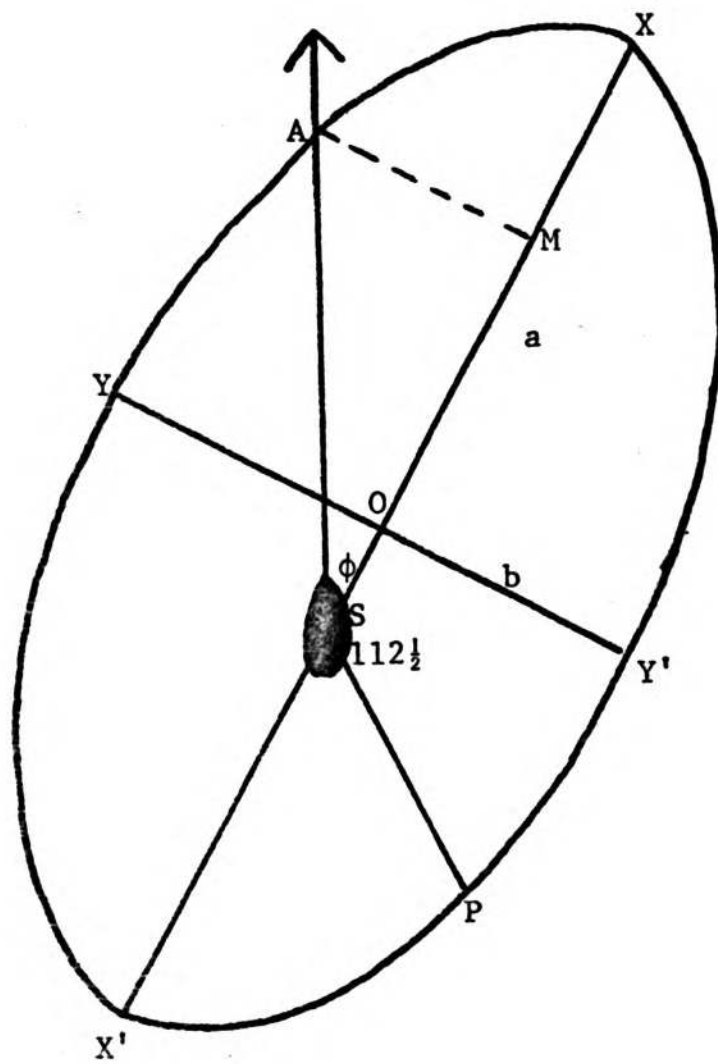

FIG. 7.2 An Approximation to the Ship Domain

solution might be as follows

Let XS = domange of Sector 1

Let AS = domange of Sector 2

Let X'S = domange of Sector 3 and

PS = domange of Sector 3

If the values for the Strait of Gibraltar are taken as an example,
XS = 1.5 n.miles, AS = 1.4 n.miles and X'S = PS = 0.6 n.miles.

Since XS + X'S = 2.1 = 2a

$$a = 1.05 \text{ n.miles}$$

Using the same reasoning as in the previous example:- b = .72 n.miles.

$$SO = .45 \text{ n.miles}$$

This is considered valid since PS can lie anywhere in Sector 3 provided $\phi + 112\frac{1}{2} < 247\frac{1}{2}$, i.e. provided $\phi < 135$. If this condition is not met the figure will not be an approximation to the domain shape.

Let AM be drawn perpendicular to XX'.

Then AM = AS sin ϕ = 1.4 sin ϕ

SM = AS cos ϕ = 1.4 cos ϕ

$$\therefore OM = 1.4 \cos \phi - .45$$

Since A lies on the ellipse, the values for AM and OM satisfy the equation of the ellipse

$$\frac{x^2}{a^2} + \frac{y^2}{b^2} = 1$$

where a = 1.05 n.miles b = 0.72 n.miles

$$\therefore \frac{(1.4 \cos \phi - .45)^2}{1.05^2} + \frac{1.4 \sin^2 \phi}{.72^2} = 1$$

Solving this gives $\phi \approx 16^\circ$.

Thus the analytical model for a ship domain in the Gibraltar Strait could be an ellipse with major semi-axis of 1.05 n.miles, semi-axis of .72 n.miles and the major axis of the ellipse inclined at an angle of 16° to the ship's head. Since there is this wide difference between the major and minor semi-axes in this situation this might well be a better model than the circular one suggested previously. All three suggestions which have been made are based purely on speculative grounds but have been put forward as possible ways in which the ship domain as

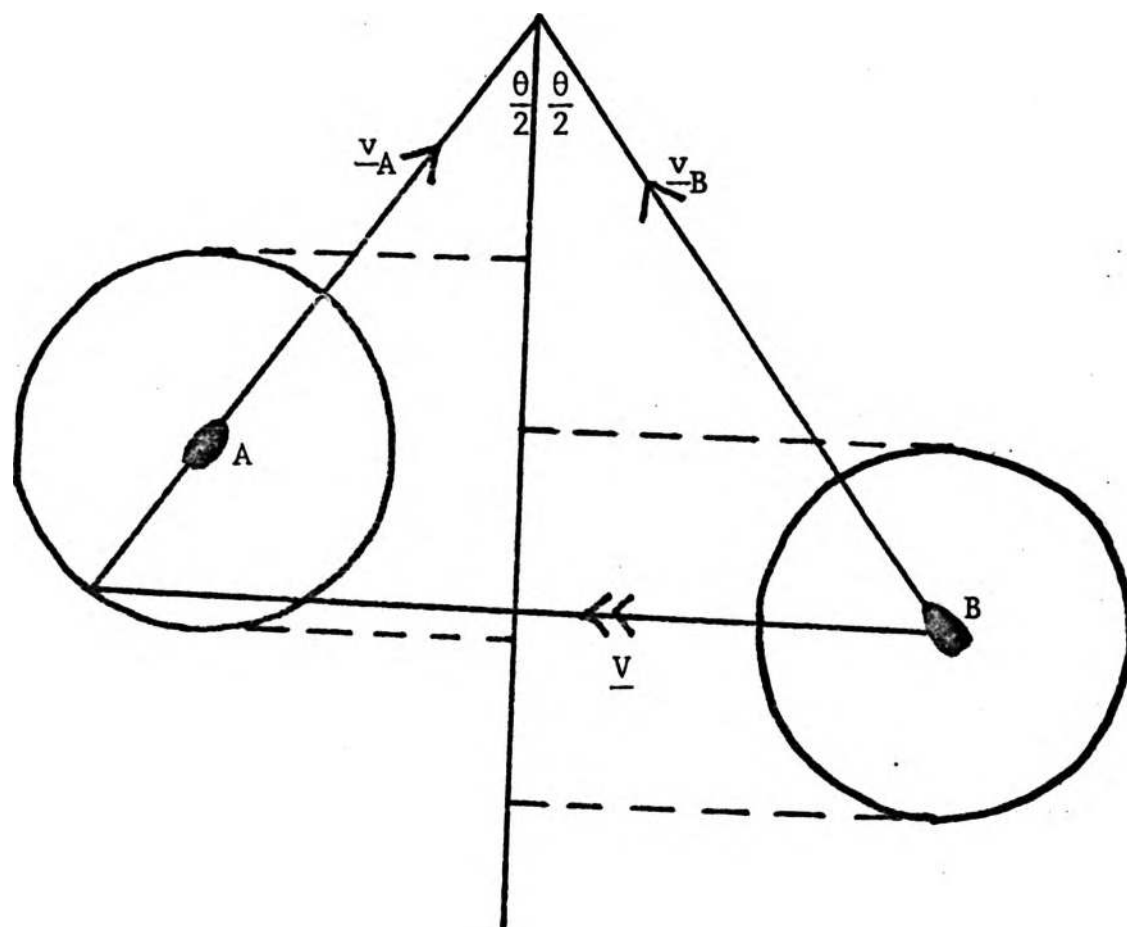

FIG. 7.3 Encounter Between two Ships

defined in this thesis could be adapted to provide a workable analytical model for encounter rates. The next stage must be to test them against actual data from all area to see which best approximates to the encounter area of the ship domain.

Method for Testing the Values of the Domanges

The concept of encounter rates can be used conversely to check the values of the domanges obtained. Consider the simplest situation where the domain is represented by a circle centred on the ship and of radius r . Assume there are two ships each moving with speed v in directions inclined at θ to each other. Fig. 7.3 illustrates this situation. There will be an encounter between the two ships requiring an avoiding manoeuvre if the projection of the centre of one ship falls within the projection of the domain of the other ship onto a line perpendicular to the relative velocity vector \underline{V} . In the diagram the relative velocity vector \underline{V} is shown directionally for the motion of ship B with respect to ship A. The projection of the diameter of the domain of one ship, moving with relative velocity \underline{V} sweeps out an area at a rate R such that

$$\begin{aligned} R &= 2rV \\ &= 4rv \sin \frac{\theta}{2} \end{aligned}$$

If movement is allowed from all directions then the limits on θ are $0 \leq \theta \leq 2\pi$. If we further assume that all values are equally likely then the probability density function for θ , $f(\theta)$, is given by

$$f(\theta) = \frac{1}{2\pi} \quad 0 \leq \theta \leq 2\pi$$

Thus the mean value of R with respect to θ

$$\begin{aligned} &= \int_0^{2\pi} \frac{4vr \sin \frac{\theta}{2}}{2\pi} d\theta \\ &= -\frac{4vr}{\pi} \left[\cos \frac{\theta}{2} \right]_0^{2\pi} \\ &= \frac{8vr}{\pi} \end{aligned}$$

*expectation
in encounter*

If n is the mean number of ships in a given area A , then the mean number of encounters, q , for each ship in unit time is given by:-

expected

$$q = \frac{8vr}{\pi} \times \frac{n-1}{A}$$

Thus the total number of encounters, N, in the area A in unit time is given by

$$N = \frac{n}{2}q$$

if each encounter between two ships is counted only as one and not two

$$\text{Thus } N = \frac{4vr n(n-1)}{\pi A}$$

If N, n, v, and A were known then a solution for r could be obtained. q could be measured from radar film of an area or obtained from ship's records as the mean number of evasive actions by a ship in passing through the area, so it should not be too difficult to calculate a value for r this way. Oshima and Fujii (1974)⁽³⁹⁾ have tried a similar method in a study in Japan. It is considered that one of the follow-up projects to this thesis should be aimed at checking the damage values using this method. It will obviously be necessary to consider the mean number of evasive actions per ship in each of the areas studied as this will be related to the area. Although it is unlikely that exactly the same values will be obtained it should at least provide a check on the order of values calculated.

TRAFFIC FLOWS

Channel Capacities

One of the most basic equations in any traffic engineering study is the equation of traffic flow:-

$$\text{volume} = \text{density} \times \text{speed.}$$

For marine traffic this equation takes the form as given by Stratton (1971)⁽³⁷⁾ :-

$$\frac{\text{No. of ships}}{\text{perimeter length} \times \text{time}} = \frac{\text{No. of ships}}{\text{Area}} \times \frac{\text{Distance}}{\text{Time}}$$

From this equation it is possible to define the basic capacity of a channel which may be thought of as the maximum number of ships that can negotiate the channel in a given unit of time assuming normal navigating conditions and ships of similar types. This is a useful concept for any traffic planning studies. Knowledge of ship domains enables these basic capacities to be calculated. Consider, for example, a channel five miles wide and five miles long. Since the Dover Strait represents the area with the highest traffic density included in this study it is

reasonable to consider the values for the domanges obtained there. If we further assume one way traffic then the closest packing of ships would be as shown in the diagram below.

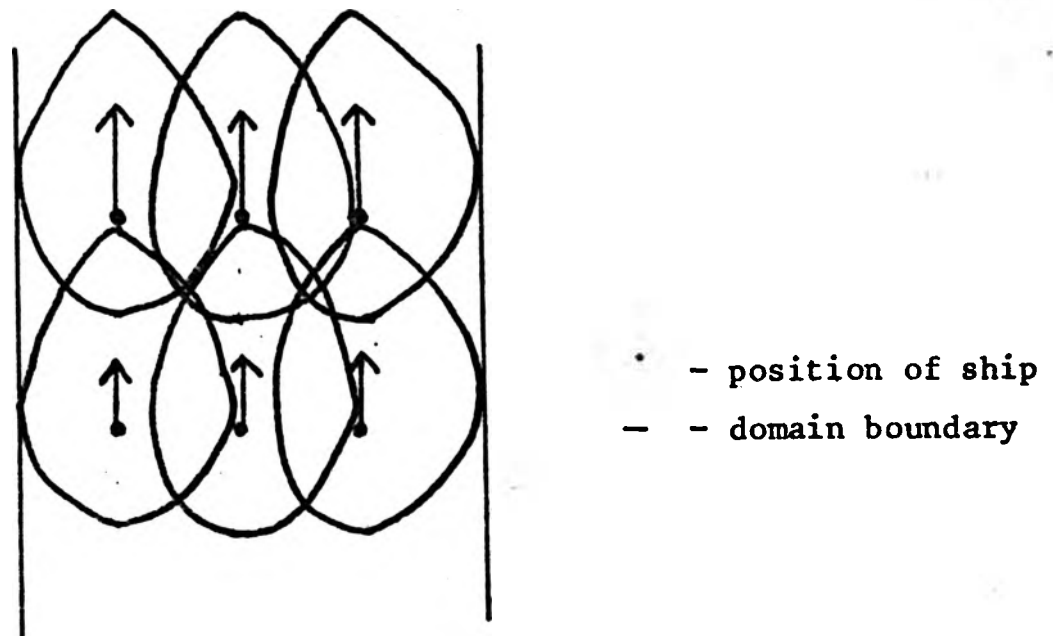

FIG. 7.4 Close Packing of Ships in a Channel

Since the Sector 1 domanges are the crucial ones in this sort of traffic, then the problem of how many ships can be present in a channel when all the ships are moving with the mean observed speed for the channel, becomes the problem of how many squares with side equal to the Sector 1 domange can be fitted into the channel dimensions. Since for the Dover Strait the Sector 1 domange = 0.8 n.m., then for this particular channel, the number of ships which can be fitted in is 36. Thus the density is $\frac{36}{25} = 1.44/\text{sq.mile}$. (Theoretically the density is $\left(\frac{1}{0.8}\right)^2 = 1.56/\text{sq.mile}$, but this involves fractions of ships which could not be included). If 13 knots is taken as the mean speed in the channel as observed in a recent Dover Strait survey⁽¹¹⁾ the basic capacity can now be calculated as $1.44 \times 13 = 19$ ships per hour per mile of channel width. The total capacity for the channel is thus $19 \times 5 = 95$ ships per hour.

The figures chosen above are purely illustrative in that they represent the typical domain size averaged over density, speed and size of ship. It was shown in Chapter 6 that there is a relationship between domain size and density and a relationship between domain size and relative velocity. In practice it is expected that there is in fact an interaction between density and speed so that the mean speed in an area reduces as the density increases.

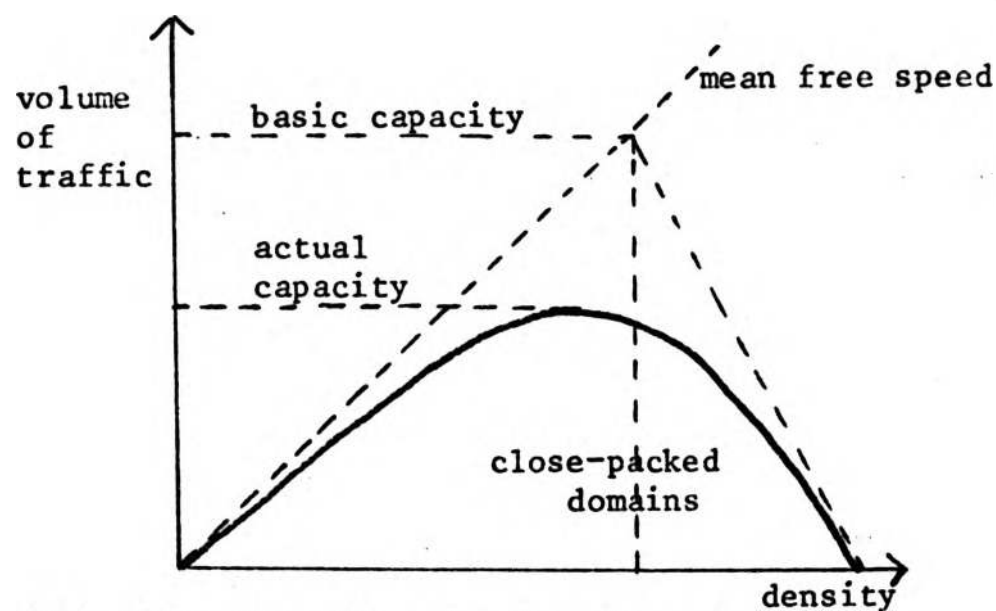

FIG. 7.5 Capacity of a Sea-channel

The diagram above is adapted from one in the paper by Stratton (1971)⁽³⁷⁾ dealing with the capacity of traffic systems. The basic capacity is calculated assuming mean free speed and average domain size, and this situation is represented by the dotted line. In practice there will probably be a reduction in speed before the basic capacity is reached and this is shown by the continuous line. The precise connection between actual and basic capacities will depend on the interrelation between speed and density but it is quite possible that the basic capacity will be larger than the actual capacity. More detailed study of the behaviour of ship domains under density and speed will enable this curve to be calibrated. A further extension of these ideas would be to incorporate the final suggestion made in the discussion of separation standards. If permitted levels of risk were also included and the accuracy distribution was known, a theoretical capacity for a channel could be calculated taking these factors into account also.

Journey Times

One important practical question which can be examined with a knowledge of traffic flows is the length of time a voyage will take. Vanags in a discussion of the economics of congestion (1972)⁽⁴⁾ suggested probable forms for time/density curves and time/flow curves. Knowledge of the relationships between domain boundary and density and domain boundary and speed could be used to calibrate these curves as well. This could be done for complete journeys and not just restricted to passages through narrow channels. The main practical problem which is likely to arise once an area with wider dimensions is chosen is the definition of traffic density around a central ship. For instance in

an open ocean the density based on a very large area, could be almost zero although there might be several other ships in the vicinity of the central ship at the time. It is suggested that a circle of five mile radius around the central ship would provide a reasonable basis for the definition of surrounding density. This could be adopted whenever the dimensions of the area being studied are so large that a five mile circle can be fitted into it.

COMPUTER SIMULATION MODELS

The final application of the ship domain geometry which will be considered here is in the building of computer simulation models. For any system under study there is always a choice of building a mathematical analytical model or simulating the system physically or numerically. Draper and Bennett (1972)⁽²⁵⁾ when considering the modelling of encounter rates in the Dover Strait chose a simple analytical approach because there was insufficient information available about the behaviour of ships and hence 'detailed analysis of extensive traffic surveys would be necessary', before more sophisticated studies could be attempted. It is suggested that the findings on ship domains in this project will now provide a suitable basis from which computer simulation models can be built. As each ship enters the system, data could be attached to it relating the required domain dimensions to the size of the ship, and giving details on the adaptation of the domain to changes in relative velocity and density. The passage of the ship through the area would be done with the dual objectives of reaching the planned destination and maintaining a clear domain. Thus before each move, all possible courses of action could be evaluated and the optimum chosen. The presence of several ships in the area will mean that it will not always be possible to maintain a clear domain and hence encounters will occur occasionally. It will also be possible to introduce obstacles into the area if required and to make the behaviour of ships with respect to them realistic. It was shown in the last chapter that the domains with respect to buoys and fishing vessels in the Sunk area were different from those with respect to other ships, so this would seem a very useful adaptation.

Once a realistic computer simulation model has been built for an area, there will be a variety of problems which it will be able to consider. This therefore could potentially be one of the most important applications of ship domain geometry.

APPRAISAL OF THE PROJECT

Having spent the first part of the chapter discussing a few of the ways in which the knowledge of ship domains may be put to practical use, it is now necessary in conclusion to consider the work that has been done and the future work that must now be started.

Conclusions

As stated in the first chapter the project is seen as a contribution to the new science of marine traffic engineering. The first step has been the establishment of the fact that a ship domain, the area around a ship required by a navigator for safe and efficient navigation, does exist. Although a related concept had been established by Japanese marine traffic engineers, the existence of a ship domain as an area completely surrounding a ship is a new idea.

The next step necessary was to establish a definition whereby the domain could be identified and hence its boundaries calculated. The definition decided upon was that a ship domain is the area immediately surrounding a ship in which the density of other ships was less than the ambient density level. A practical method for evaluating the range of the domain boundary from the ship, the domange, has then been established referred to as the method of displaced numbers. It has also been possible to give a measure of accuracy for the domanges by estimating their standard errors.

The domain was treated in three separate sectors around the ship defined by the maritime collision regulations. It has thus been possible to show that the shape of the domain as well as its size changes under the influence of independent variables.

The main findings of the effects of independent variables are summarised below.

1. Area

For all the areas considered, the shape of the domain remained more or less constant, with the largest domange in the starboard bow sector, Sector 1 and the smallest domange in the sector astern of the ship, Sector 3. The size however depended on the density of ships and the general scope for manoeuvring in an area. Thus the largest dimensions were in the open ocean, with those for the Strait of Gibraltar much smaller

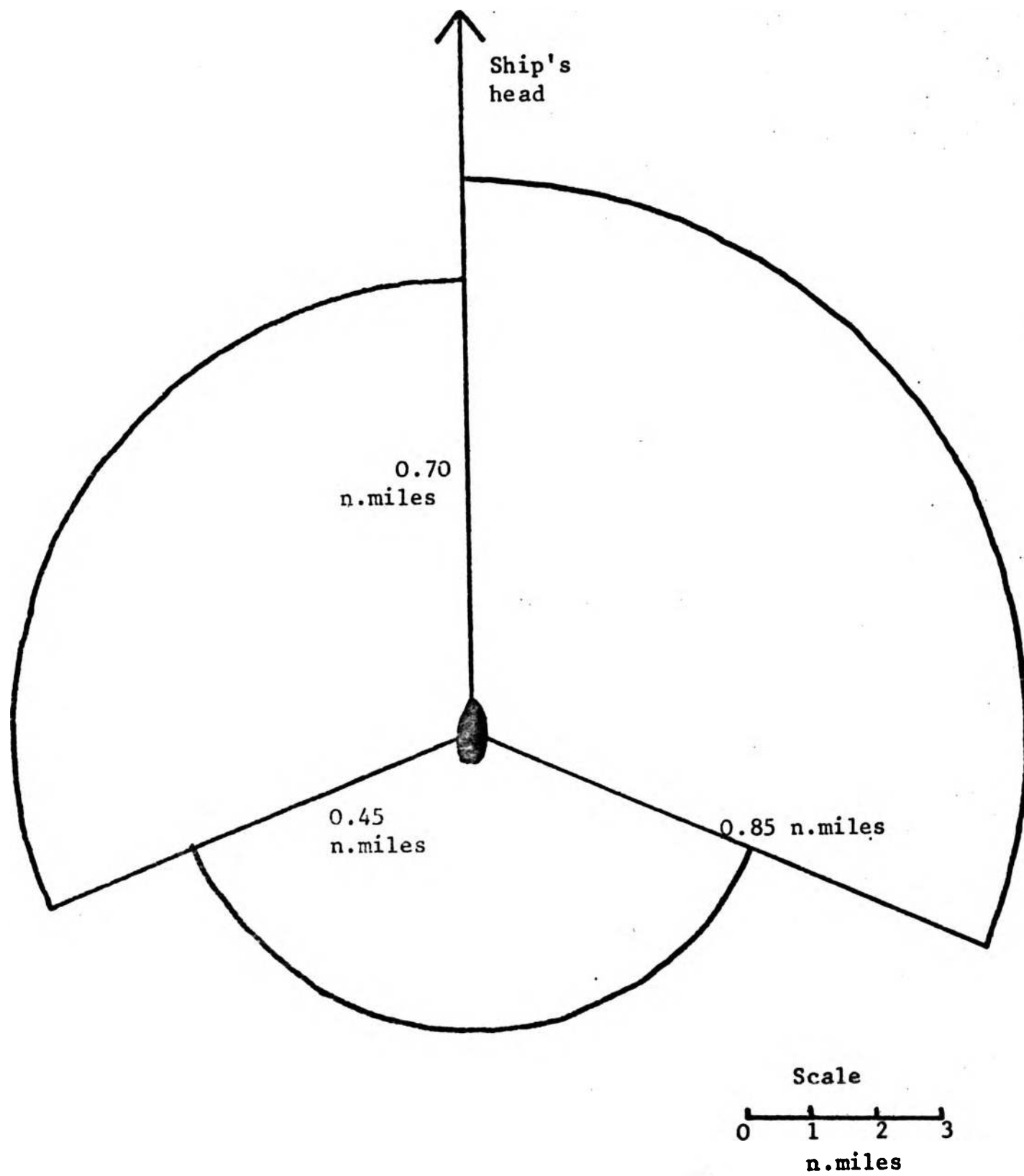

FIG. 7.6 A Ship Domain for the Sunk Area of the North Sea

and those for the Dover Strait even smaller. It would appear that average values need to be established separately for any area where the concept of ship domain is to be applied. Within the Sunk area it has been shown that all three domanges get smaller as density increases but this effect is particularly marked in the third sector, astern of the ship. Fig. 7.6 shows an average domain drawn to scale for the Sunk area.

2. Relative Velocity

The pattern suggested by changes in relative velocity is that the starboard bow domanges increase as relative velocity increases. Domanges in the other two sectors are less affected but if anything have a tendency to decrease as the relative velocity increases. Thus the shape of the domain becomes rather variable but the actual area it covers seems less so.

3. Size of the Ship

Using either gross tonnage or the length of a ship as a measure of its size, there seems to be an increase in the domanges in all three sectors as the size of the ship increases. This is particularly noticeable in the sector astern of the ship and to a lesser extent in the starboard bow sector. From the simulator data results especially, it also appears that there is a finite limit to the increase in size dependent probably on the area. For very large ships the domain has become circular, suggesting that the other ships in the area take the more active role in collision avoidance. Apart from this the shape of the domain does not alter considerably.

4. Maximum Speed of a Ship

It would appear that this is not a very suitable variable on its own to predict domain size, since no obvious pattern emerges.

5. Length of Sea-experience of the Navigator

The pattern here was rather interesting as in both Sectors 1 and 2 there appears to be a decrease in domain size as experience increases. This however is contradicted by very low values in the least experienced group and rather high values in the most experienced group. The Sector 3 values increase as experience increases so there is also a change in shape. More data is certainly needed here before any firm conclusions can be drawn.

6. Fishing Vessels

The tentative conclusions reached are that fishing vessels keep a domain with respect to other fishing vessels but of greatly reduced dimensions. Non-fishing vessels however prefer to have a domain of slightly larger dimensions than for other ships in the area, when passing fishermen. The shape in each case is more circular than is the case amongst non-fishing vessels.

7. Buoys

When passing a buoy ships appear to leave much more distance if it is on the starboard bow than anywhere else. The concept of a domain still exists but all dimensions are much smaller than for the domain with respect to other ships.

The conclusions above on the effects of various independent variables on a ship domain have been presented in a rather tentative form, because in any statistical project the mere presence of variation means that conclusions can never be drawn definitely and finally. It is felt that much more data is needed to investigate the relationships more precisely but the results so far certainly indicate that further study of the ship domain concept is worthwhile.

Before considering the future development of the ideas on ship domains, there are some further conclusions to be drawn from this particular project which in fact may have much wider reaching consequences.

It has been demonstrated in this project that a marine radar simulator provides a very realistic, efficient and in this case, cheaper method of conducting research than a marine traffic survey. The real-life survey data and the simulator data can be compared on the results obtained by relative speed, class of ship and even by area. The results on the first two variables are remarkably consistent, bearing in mind that they are taken in different sea areas as well as by different methods. The comparison by area is also very realistic as it was felt that behaviour in a crowded area, like the Dover Strait, in fog would be similar to behaviour in a slightly less crowded area, such as the vicinity of the Sunk lightvessel, in clear weather. Since it is easily possible to measure more variables using the simulator and to some extent exercise control over some of them, it is felt that much more use should be made of a simulator for marine traffic research. It would be interesting to compare the results obtained on a visual simulator

with results obtained in an equivalent real-life area to see if there is any measurable quantity which could be termed 'simulator effect' which might distort results a little. However, the conclusion from this study is, that it is certainly not very marked if it is there, and hence the simulator does provide a very viable alternative to a traffic survey for research into the behaviour of navigators.

The actual method used for the traffic survey has proved to be very satisfactory and it is hoped that a similar approach can be used for other projects if real-life data is required. It is an excellent introduction for a research worker who is not initially conversant with the practical side of navigation, to go out on a ship to survey rather than to use shore-based records.

The methods of data processing developed in this project are also considered to have much future practical use. The approach used for the sunk survey data is considered to be the best, whereby the position of each ship at each time point is measured in cartesian coordinates related to a fixed origin and axes arbitrarily sited in the area. The time-independent variables such as tonnage, length, experience and maximum speed can be read in as lists and stored against the ship number, but the time dependent variables such as position in the area and a measure of speed must be carried as a vector with the time and ship number to which they relate. From further work which has now been undertaken, it has been found very simple to adapt the programs to calculate other quantities of interest from the basic data inputs. It should also be reasonably straightforward to adapt data from other surveys to be run with these programs.

It is thus felt that the work on data collection and processing has produced results which will be of use to other projects, not only any extensions of this one.

FUTURE WORK ON SHIP DOMAINS

From the earlier discussions, it is clear that the first need is for more data to be collected and analysed. For a particular area it is necessary to establish the precise relationship between domain size and density, between domain size and relative velocity, between domain size and ship size and in general between domain size and any other variables of interest. It would also be useful to examine the interactions between the variables, for instance the relationship between domain size

and a combination of ship size, density and relative velocity.

Different areas should be studied since there is obviously a relationship between domain size and shape and area. It would also be useful to study more variables than have been looked at here. Different personality factors of the navigator could best be studied using the simulator and more work should be done on the navigator's length of sea-experience. Weather conditions is another factor which it would be useful to examine and the use of a visual marine simulator might be of help here.

There is also more work to be done on the methods of analysing the data. A further investigation of suitable analytical models for the distribution of ships around the central ship would be valuable. This would make the calculation of the domanges and their standard errors much easier if an analytical model could be developed. In any case a further investigation of the sampling distributions of the domanges is needed.

For different situations it may also be advisable to subdivide the domain into alternative sectors. In a channel, the best division for instance might be a four-way one, one sector ahead, one astern, one port beam and one starboard beam. Another useful adaptation would be to consider routeing systems and the effects of crossing traffic. The four types of traffic which might be encountered viz:- ships travelling in the right direction, rogues travelling in the wrong direction, and crossing traffic in each direction, should perhaps be analysed separately and the sectors again defined differently.

Finally as suggested at the start of the chapter, the other main extension of the project is into practical applications. A few specific suggestions have been discussed in a little detail to show how the ideas could be implemented in practice. It is however felt that very many studies into the behaviour of marine traffic could profitably make use of the basic ideas put forward in this thesis.

SUMMARY

Although subdivided into sections, the applications of ship domains, an appraisal of the work done in the project so far and the future extensions of the project, the chapter is seen in its entirety as an evaluation of the topic of ship domains. Much has been learnt about

ship domains, but there is still much more to establish. However as has been shown in the applications, it should prove to be a very valuable concept in marine traffic engineering.

APPENDIX I Additional Tables Accompanying Chapter 1

| Vessel Type | Tankers | Ore and Bulk Carriers | General Cargo & Passenger | Fishing | Others | Total |
|-----------------|---------|-----------------------|---------------------------|---------|--------|-------|
| Total Ship 1969 | 5869 | 2378 | 26100 | 11949 | 3980 | 50276 |
| Population 1980 | 7980 | 4115 | 16467 | 17900 | 23554 | 70016 |
| Number at 1969 | 4637 | 1474 | 5269 | 9323 | 270 | 20973 |
| Sea 1980 | 6300 | 2715 | 4978 | 13950 | 2494 | 30437 |
| Percentage 1969 | 79 | 62 | 20 | 78 | 7 | 42 |
| Use 1980 | 79 | 66 | 30 | 78 | 11 | 43 |

Notes (see p. 322)

TABLE I.1 Comparison of the Ship Populations for 1969 and 1980 (Estimated)

The above table provides a further comparison of the ship populations of 1969 and 1980 (estimated). The numbers expected at sea are perhaps more meaningful for planning purposes, than the total ship populations, quoted in the main text. However, the numbers expected at sea are based on projected utilisation rates which means the introduction of yet another unknown factor. Derivation of the utilisation rate is given by Thompson (1972)⁽¹⁾ in his paper on the projected ship populations for 1980. In particular the high figures for the use of tankers and fishing vessels are interesting compared to the low figures for general cargo ships and passenger ships.

| Gross Tonnage | Type of Ship Year | Oil Tankers | | Other Ships | | Total | |
|-----------------|----------------------|-------------|------|-------------|-------|-------|-------|
| | | 1963 | 1973 | 1963 | 1973 | 1963 | 1973 |
| 100 - 499 | | 1176 | 1474 | 14728 | 27096 | 15904 | 28570 |
| 500 - 999 | | 411 | 731 | 3866 | 5566 | 4277 | 6297 |
| 1000 - 1999 | | 322 | 523 | 2933 | 3959 | 3255 | 4482 |
| 2000 - 3999 | | 193 | 441 | 3426 | 4821 | 3619 | 5262 |
| 4000 - 5999 | | 57 | 77 | 1955 | 2255 | 2012 | 2332 |
| 6000 - 7999 | | 120 | 88 | 4539 | 2261 | 4659 | 2349 |
| 8000 - 9999 | | 286 | 159 | 1658 | 2474 | 1944 | 2633 |
| 10000 - 14999 | | 1319 | 897 | 1104 | 2260 | 2423 | 3157 |
| 15000 - 19999 | | 328 | 417 | 215 | 978 | 543 | 1395 |
| 20000 - 29999 | | 601 | 645 | 128 | 613 | 729 | 1258 |
| 30000 - 39999 | | 133 | 381 | 24 | 294 | 157 | 675 |
| 40000 - 59999 | | | 316 | | 250 | | 566 |
| 60000 - 79999 | | | 90 | | 94 | | 184 |
| 80000 - 99999 | | | 69 | | 55 | | 124 |
| 100000 - 119999 | | 38 | 197 | 11 | 12 | 49 | 209 |
| 120000 - 139999 | | | 78 | | 6 | | 84 |
| 140000 and over | | | 24 | | 5 | | 29 |
| Total | | 4984 | 6607 | 34587 | 52999 | 39571 | 59606 |

Notes (see p.322).

TABLE I.2 Comparison of the Distributions of the World's Ships by Size and by Type in 1963 and 1973

APPENDIX II. I

EXTRACT FROM THE HIGHWAY CODE (1968)⁽¹⁸⁾

Leave enough space between you and the vehicle in front so that you can pull up safely if it slows down or stops suddenly. The safe rule is never to get closer than the overall stopping distance shown below. But on the open road, in good conditions, a gap of one yard for each m.p.h. of your speed may be enough. On wet or icy roads the gap should be much more. Drop back if an overtaking vehicle fills the gap in front of you.

Shortest Stopping Distances - in Feet

| m.p.h. | Thinking Distance | Braking Distance | Overall Stopping Distance |
|--------|----------------------|---------------------|---------------------------------|
| 20 | 20 | 20 | 40 |
| 30 | 30 | 45 | 75 |
| 40 | 40 | 80 | 120 |
| 50 | 50 | 125 | 175 |
| 60 | 60 | 180 | 240 |
| 70 | 70 | 245 | 315 |

APPENDIX II.II

EXTRACTS FROM THE INTERNATIONAL REGULATIONS FOR PREVENTING COLLISIONS

AT SEA, 1960 - Effective from September 1, 1965.

Rule 16

(a) Every vessel, or seaplane when taxi-ing on the water, shall, in fog, mist, falling snow, heavy rainstorms or any other condition similarly restricting visibility, go at a moderate speed having careful regard to the existing circumstances and conditions.

(b) A power-driven vessel hearing, apparently forward of her beam, the fog-signal of a vessel the position of which is not ascertained, shall, so far as the circumstances of the case admit, stop her engines, and then navigate with caution until danger of collision is over.

(c) A power-driven vessel which detects the presence of another vessel forward of her beam before hearing her fog signal or sighting her visually may take early and substantial action to avoid a close quarters situation but, if this cannot be avoided, she shall, so far as the circumstances of the case admit, stop her engines in proper time to avoid collision and then navigate with caution until danger of collision is over.

PART D - STEERING AND SAILING RULES

Preliminary

1. In obeying and construing these Rules, any action taken should be positive, in ample time, and with due regard to the observance of good seamanship.
2. Risk of collision can, when circumstances permit, be ascertained by carefully watching the compass bearing of an approaching vessel. If the bearing does not appreciably change, such risk should be deemed to exist.
3. Mariners should bear in mind that seaplanes in the act of landing or taking off, or operating under adverse weather conditions, may be unable to change their intended action at the last moment.
4. Rules 17 to 24 apply only to vessels in sight of one another.

Rule 17

(a) When two sailing vessels are approaching one another, so as to involve risk of collision, one of them shall keep out of the way of the other as follows:-

(i) When each has the wind on a different side, the vessel which has the wind on the port side shall keep out of the way of the other.

(ii) When both have the wind on the same side, the vessel which is to windward shall keep out of the way of the vessel which is to leeward.

(b) For the purposes of this Rule the windward side shall be deemed to be the side opposite to that on which the mainsail is carried, or, in the case of a square-rigged vessel, the side opposite to that on which the largest fore-and-aft sail is carried.

Rule 18

(a) When two power-driven vessels are meeting end on, or nearly end on, so as to involve risk of collision, each shall alter her course to starboard, so that each may pass on the port side of the other. This Rule only applies to cases where vessels are meeting end on, or nearly end on, in such a manner as to involve risk of collision, and does not apply to two vessels which must, if both keep on their respective course, pass clear of each other. The only cases to which it does apply, are when each of two vessels is end on, or nearly end on, to the other; in other words, to cases in which, by day, each vessel sees the masts of the other in a line, or nearly in a line, with her own; and by night, to cases in which each vessel is in such a position as to see both the sidelights of the other. It does not apply, by day, to cases in which a vessel sees another ahead crossing her own course; or, by night, to cases where the red light of one vessel is opposed to the red light of the other or where the green light of one vessel is opposed to the green light of the other or where a red light without a green light or a green light without a red light is seen ahead, or where both green and red lights are seen anywhere but ahead.

(b) For the purposes of this Rule and Rules 19 to 29 inclusive, except Rule 20(c) and Rule 28, a seaplane on the water shall be deemed to be a vessel, and the expression "power-driven vessel" shall be construed accordingly.

Rule 19

When two power-driven vessels are crossing, so as to involve risk of collision, the vessel which has the other on her own starboard side shall keep out of the way of the other.

Rule 20

(a) When a power-driven vessel and a sailing vessel are proceeding in such directions as to involve risk of collision, except as provided for in Rules 24 and 26, the power-driven vessel shall keep out of the way of the sailing vessel.

(b) This Rule shall not give to a sailing vessel the right to hamper, in a narrow channel, the safe passage of a power-driven vessel which can navigate only inside such channel.

(c) A seaplane on the water shall, in general, keep well clear of all vessels and avoid impeding their navigation. In circumstances, however, where risk of collision exists, she shall comply with these Rules.

Rule 21

Where by any of these Rules one of two vessels is to keep out of the way, the other shall keep her course and speed. When, from any cause, the latter vessel finds herself so close that collision cannot be avoided by the action of the giving-way vessel alone, she also shall take such action as will best avert collision (see Rules 27 and 29).

Rule 22

Every vessel which is directed by these Rules to keep out of the way of another vessel shall, so far as possible, take positive early action to comply with this obligation, and shall, if the circumstances of the case admit, avoid crossing ahead of the other.

Rule 23

Every power-driven vessel which is directed by these Rules to keep out of the way of another vessel shall, on approaching her, if necessary, slacken her speed or stop or reverse.

Rule 27

In obeying and construing these Rules due regard shall be had to all dangers of navigation and collision, and to any special circumstances, including the limitations of the craft involved, which may render a departure from the above Rules necessary in order to avoid immediate danger.

APPENDIX III.I

MARINE RADAR SIMULATOR
SERIES SY2010

1. INTRODUCTION AND BRIEF DATA

1.1 Introduction

The Solartron transistorised radar simulator series SY2010 is designed to provide a synthetic, but highly realistic, means of training pupils in the interpretation of data presented to them on the display units of a typical marine radar.

1.1.1 The Equipment

In order that the SY2010 range of simulators is able to meet different marine radar training requirements, the equipment has been constructed to give a selection of modules which together provide a variety of simulator functions.

The basic equipment offers a maximum of ten targets for a single own ship system, and up to four or five targets for the two and three own ship systems. The own ship moving base is fully manoeuvrable and can be made to represent a large range of vessels, by virtue of a number of preset adjustments which determine the characteristic delays between demand and achievement in changes of course and speed. These delays vary considerably from ship to ship depending on such factors as water-line length, beam, number and type of engines and so on. These delays are switched out when the own ship is capable of performing as a hovercraft.

Realism of the responses displayed is enhanced by the inclusion of simulated receiver noise, sea clutter, mast/funnel blanking (shadow sector). In addition, coastline responses are displayed to represent selected locations with simulated automatic coastline shadowing. Tidal stream speed and direction can be set in as required, and, where the own ship doubles as a hovercraft, wind speed and direction can be set in to affect the hovercraft movement

The transistorised simulator possesses a high degree of inherent reliability and is designed to maintain stated accuracies over long periods with little or no adjustment. Fault finding and maintenance is greatly simplified by the modular construction, permitting substitution checking and sub-unit replacement.

1.1.1.1 Summary of Units

Each simulator in the series comprises the following main units:

- (a) One double-bay or treble-bay rack assembly housing the computing and coastline generating equipment (including power units).
- (b) One, two or three own ship control units.
- (c) One/two target control units.
- (d) One instructor's control unit (normally with three own ship systems only).
- (e) One junction box (two and three own ship configurations).

1.1.2 Arrangement of Manual

The manual is divided into two parts, Part 1 comprising the system description, operating instructions and system maintenance and Part 2 the unit and sub-unit descriptions, schedules and interconnection data.

1.1.2.1 Part 1

Section 1 summarises the facilities and lists the units making up the specific equipment. Section 2 provides operating instructions while Section 3 gives some treatment of the circuits employed in this type of equipment.

A detailed description of the system is contained in Section 4, and Section 5 provides maintenance instructions. Section 6 contains the system setting-up procedure.

1.1.2.2. Part 2

Part 2 of the manual comprises the relevant circuit diagrams, component lists, component location data (where available) and circuit description for the individual sub-units in numerical order.

1.2 Data Summary

1.2.1 Purpose

The purpose of each radar simulator is to provide artificial echoes on PPI displays, representing the target vessels, the other own ship/s (as applicable) and a coastline, as observed from one/two/three moving radar-carrying vessels.

1.2.2 Environment

- Playing Area : a square of side 60 nautical miles. Two controls enable the initial position of each target and own ship to be set in terms of Northings and Eastings up to 30 nm from the centre of the playing area.
- Coastline : The playing area is extended by 15 nm in each direction to allow the full range of coastline to be seen from the edge of the playing area, thus making a total viewing area of 90 x 90 nm.

1.2.3 Simulated Radar Head Characteristics

- Aerial Rotation : 20 RPM fixed.
- Horizontal Angular Beamwidth : an effective angle of 1° , increasing by a factor of 3:1 as range decreases between 30% and 3% of maximum radar range (i.e. accounting for the returns due to side-lobes).

1.2.4 Radar Characteristics

- Pulse Length : 0.2 μ S.
- PRF : 800/1,000 RPS.
- Sea Clutter : maximum range 5 miles, decaying at the rate of approximately 10dB/1,000 yards.
- Noise : variable intensity receiver noise.

1.2.5 Target Response Characteristics

- Speed : variable from 0 to 30 knots \pm 2% of maximum.
- Course : $0-360^{\circ} \pm 2^{\circ}$ at maximum speed.
 $\pm 4^{\circ}$ at 10% of maximum speed.
- Range of 1st detection : continuously variable from 20% to 100%

1.2.6 Own Ship Controls

- Course : the course of the own ship is varied by the HELM control (calibrated 30° PORT - 0 - 30° STARBOARD with a positive indication of the "midships" position), within the characteristic limitations set-in on the preset controls detailed below.

Speed Telegraph : STOP, DEAD SLOW, SLOW, HALF and FULL both ahead and astern. Actual speed is indicated on a calibrated meter.

1.2.6.1. Own Ship Characteristic Preset Controls

(a) Maximum Ahead Speed : continuously variable from 0 to 30 knots.

(b) Maximum Astern Speed : continuously variable from 0 to 15 knots.

(c) Ahead Speed Adjustments : HALF speed preset enables variation of 0.65-0.75 of maximum set in (a).
SLOW preset enables variation of 0.45-0.55 of maximum.

DEAD SLOW preset enables variation of 0.25-0.35 of maximum.

(d) Rudder Delay : continuously variable from 5 to 30 seconds after change is demanded.

(e) Speed Delay : the circuitry ensures that changes of speed conform to the following laws:

$$\text{Acceleration: } S = (V - v)(1 - e^{-t/k}) + v$$

$$\text{Deceleration: } S = (V - v)e^{-t/k} + v$$

where S = speed t minutes after change has been made

V = higher speed

v = lower speed

k = a constant depending upon type of ship.

Provision is made for continuous variation of "k" between values of 2 and 20 by means of the preset control.

(f) Maximum Rate of Turn : continuously variable 50 to 120° per minute.

(g) Loss of Speed in Turn : switched in proportions of 0, 10%, 20% or 30% of actual speed at commencement of turn.

(h) Shadow Sector ON/OFF : switches in a blind sector representing that created by the funnel or superstructure.

(j) Speed Delay Override : enables own ship speed to be set quickly at the commencement of an exercise.

(k) Set Heading : enables own ship heading to be set quickly at the commencement of an exercise.

(l) Speed Meter ON/OFF : switches speed meter out of circuit if not required for student's use.

(m) Video ON/OFF : switches off own ship response, if necessary.

(n) Range of Detection : determines range of first detection by other own ship/s (if simulated).

1.2.7 Three Own Ship Simulator

1.2.7.1 Target and Own Ship Speeds

In the three own ship system the following speeds are provided as standard:

Own Ship : Two scales are provided, 0-30 knots and 0.90 knots to simulate hovercraft/hydrofoil speeds.

Targets : 0-100 knots.

1.2.7.2. Coastline Generator

A time-sharing arrangement enables the coastline responses to be seen by all three own ships. The responses are produced from a single transparency and the figures quoted previously are modified as follows:

- (a) Maximum range of responses: 12 nm.
- (b) Minimum range of responses: $\frac{1}{4}$ nm.
- (c) Positional tolerance of coastline feature: 2% of area side.

1.2.8 Accuracies

1.2.8.1 Method of Computing

Briefly, the method of computing and converting positional data is as follows:

- (a) All own ships and targets are given an initial position in terms of cartesian co-ordinates, the results of subsequent movements also being resolved and integrated into these terms.
- (b) Positions of all ships and targets relative to each own ship are established as rectangular displacements.
- (c) Positional information is then resolved in terms of range and bearing.

1.2.8.2 Cartesian Co-ordinate Positions

The computation of the present position of each own ship and each target in relation to the integrated effects of course and speed is referred to the centre of the playing area. This "actual" position of the target can best be verified by reading the co-ordinate voltages on a digital voltmeter or similar device. The accuracy to which the target and ship controls determine these positions within the playing area are

as follows:

(a) Initial Position

Targets and own ship/s can be set anywhere in a square playing area of 60 nm side to an accuracy of $\pm 2\%$ of playing area side.

(b) Heading

The accuracy of course set to course made good related to speed as follows:

- (i) $\pm 2^\circ$ at maximum speed
- (ii) $\pm 4^\circ$ at 10% of maximum speed.

(c) Speed

The accuracy of indicated speed is as follows:

- (i) Target Ship : $\pm 5\%$ or $\frac{1}{2}$ knot, whichever is greater.
- (ii) Own Ship/s : $\pm 5\%$ or $\frac{1}{2}$ knot, whichever is greater.
- (iii) Target Aircraft/Helicopter/Hovercraft : 2% of maximum.

1.2.8.3 Relative Cartesian Co-ordinates

These are obtained by subtracting the co-ordinates of each own ship from each of the targets and each of the other own ships (if simulated), and is performed to an accuracy of 0.3% of playing area side.

1.2.8.4 Relative Ranges and Bearings

In generating the range and bearing from the relative cartesian coordinates the following accuracies apply:

- (a) Range : the range accuracy of any own ship to another own ship or target is $\pm 2\%$ of maximum radar range (maximum radar range - 15 nm).
- (b) Bearing : the bearing accuracy of any own ship to another own ship or target is $\pm 1^\circ$ at maximum radar range and better than $\pm 5^\circ$ at 10% of maximum radar range.

1.2.9. Simulator Outputs

The trainer normally provides sync, video and anti-clutter signals to the displays.

1.2.10 Power Supplies

The equipment requires the following AC mains supply:

- (a) Voltage : 220-240V RMS stable to $\pm 10\%$
- (b) Frequency : 50 c/s ± 2 c/s.

1.3 Specific Features of Radar Simulator Type SY2013A

Marine radar simulator Type SY2013A simulates three own ships and four targets, and includes a number of non-standard features.

1.3.1 Own Ship Control Unit

This is a standard unit with the added facility of GIGANTIC SHIP simulation. A single switch increases the speed and rudder delays by a factor of approximately 4:1.

1.3.2 Other Own Ship Facilities

As well as the main own ship control unit, each own ship is equipped with a second control unit enabling preset course selection and facilitating operation as a hovercraft.

(a) Preset Course Selector

This part of the control unit includes a heading dial, helm control and a NORMAL/DEMANDED switch. In the NORMAL position of this switch the own ship operates from the main own ship control unit, but in the DEMANDED position the own ship automatically turns onto a new heading at a rate determined by the helm control on this unit. As soon as the new heading is achieved a lamp indicates this state and the course is maintained until a fresh heading is set in.

(b) Hovercraft Operation

This is controlled effectively by a speed selector switch, 0-30/0-90, the 0-90 position selecting operation of the own ship as a hovercraft. The speed and helm controls on the own ship control unit are then replaced by controls on this unit, and the preset course selector becomes inoperative.

1.3.3 Yaw

Switched facilities for introducing yaw into the own ship's motion is provided. Three amplitudes are available for each own ship - 2° , 4° or 6° .

1.3.4 Wind and Tide

All targets are affected by the tidal stream set in, but, since the own ships are capable of operating as ships or hovercraft, a choice of wind or tide effect is available for each own ship.

1.3.5 Azimuth Stabilisation

The turning information generated by the simulator is inherently north stabilised, but, because the display equipment is designed to operate from unstabilised data, it is necessary to unstabilise the information available to the displays. Azimuth stabiliser units are included to achieve this, one for each own ship display, and each houses repeaters for own ship speed and heading.

APPENDIX III.II

Initial Situations for the Simulator Exercises

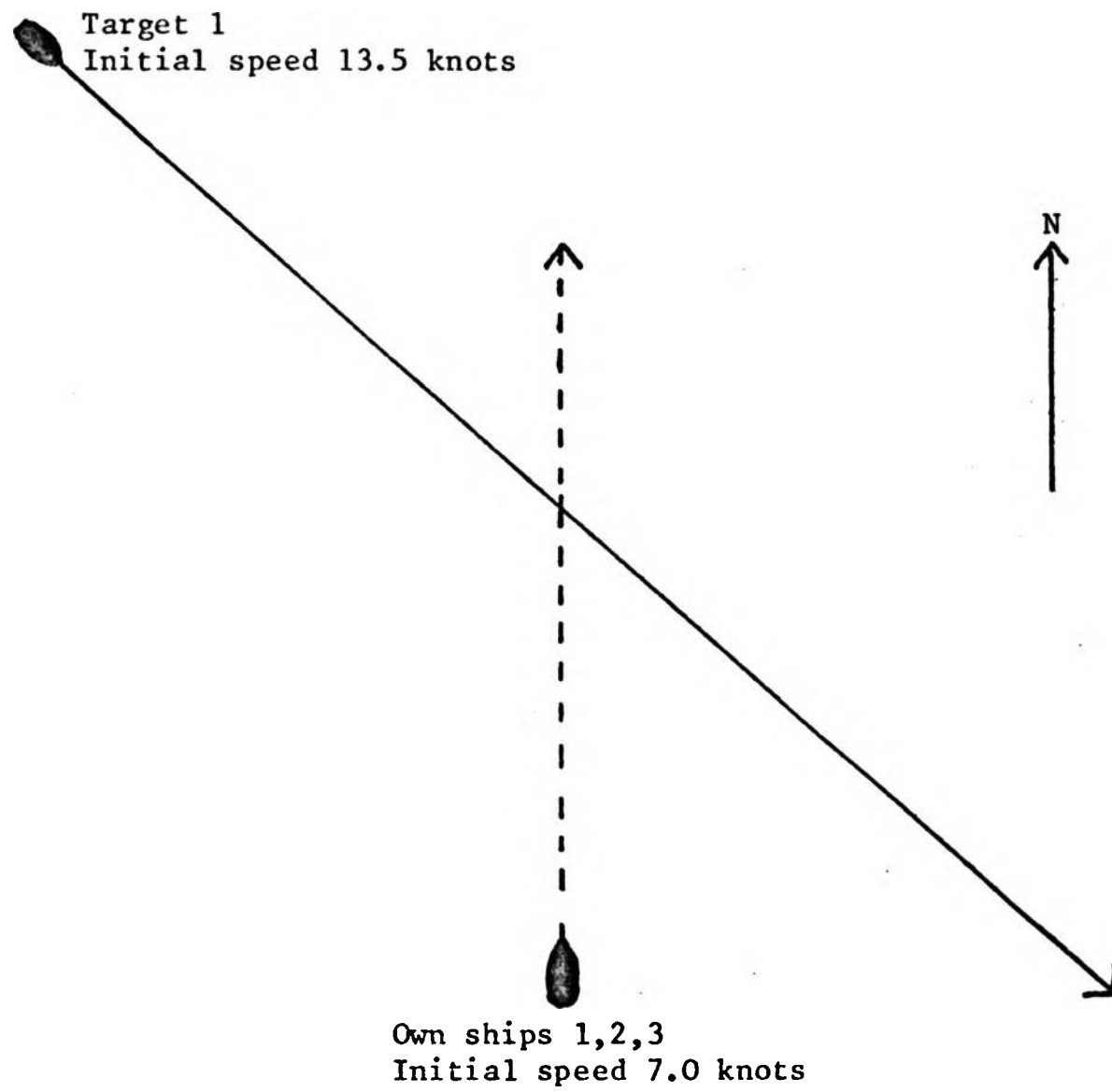

Scale: $\frac{1}{4}$ " represents 1 nautical mile

FIG. III.1 Open Ocean: Exercise 1 Initial Situation

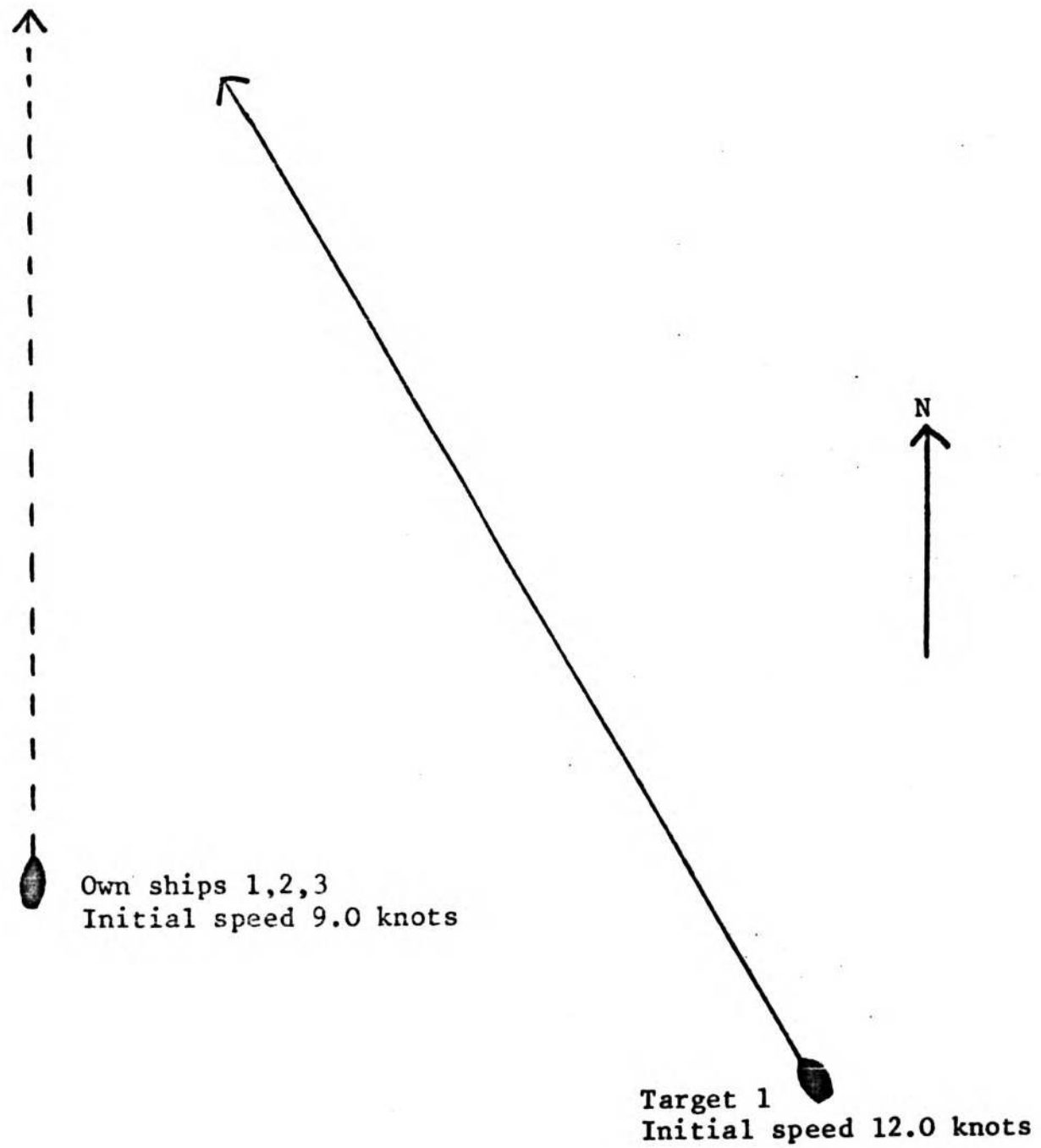

Scale: $\frac{1}{2}$ " represents 1 nautical mile.

FIG. III.2 Open Ocean: Exercise 2 Initial Situation

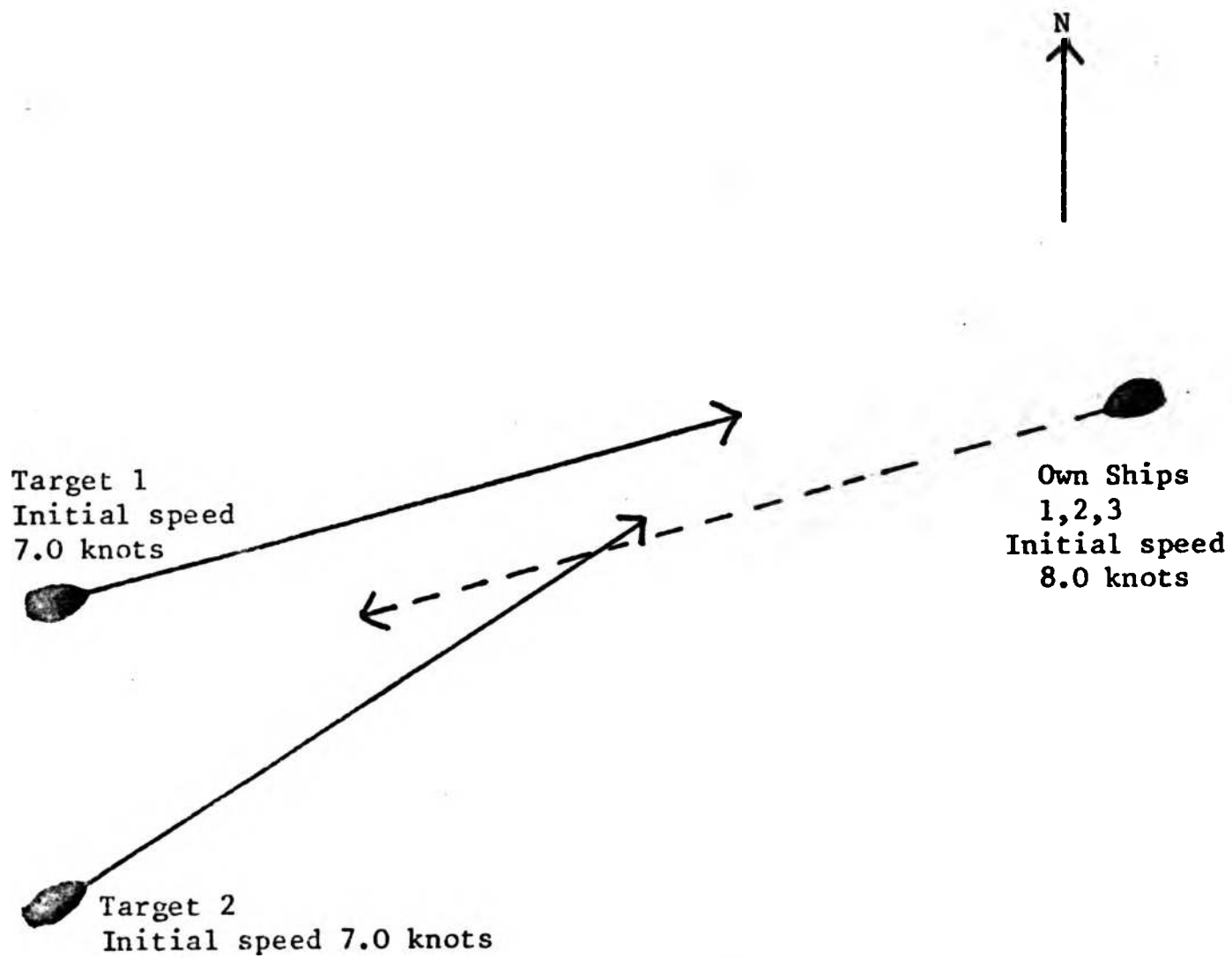

Scale: $\frac{1}{2}$ " represents 1 nautical mile

FIG. III.3 Open Ocean: Exercise 3: Initial Situation

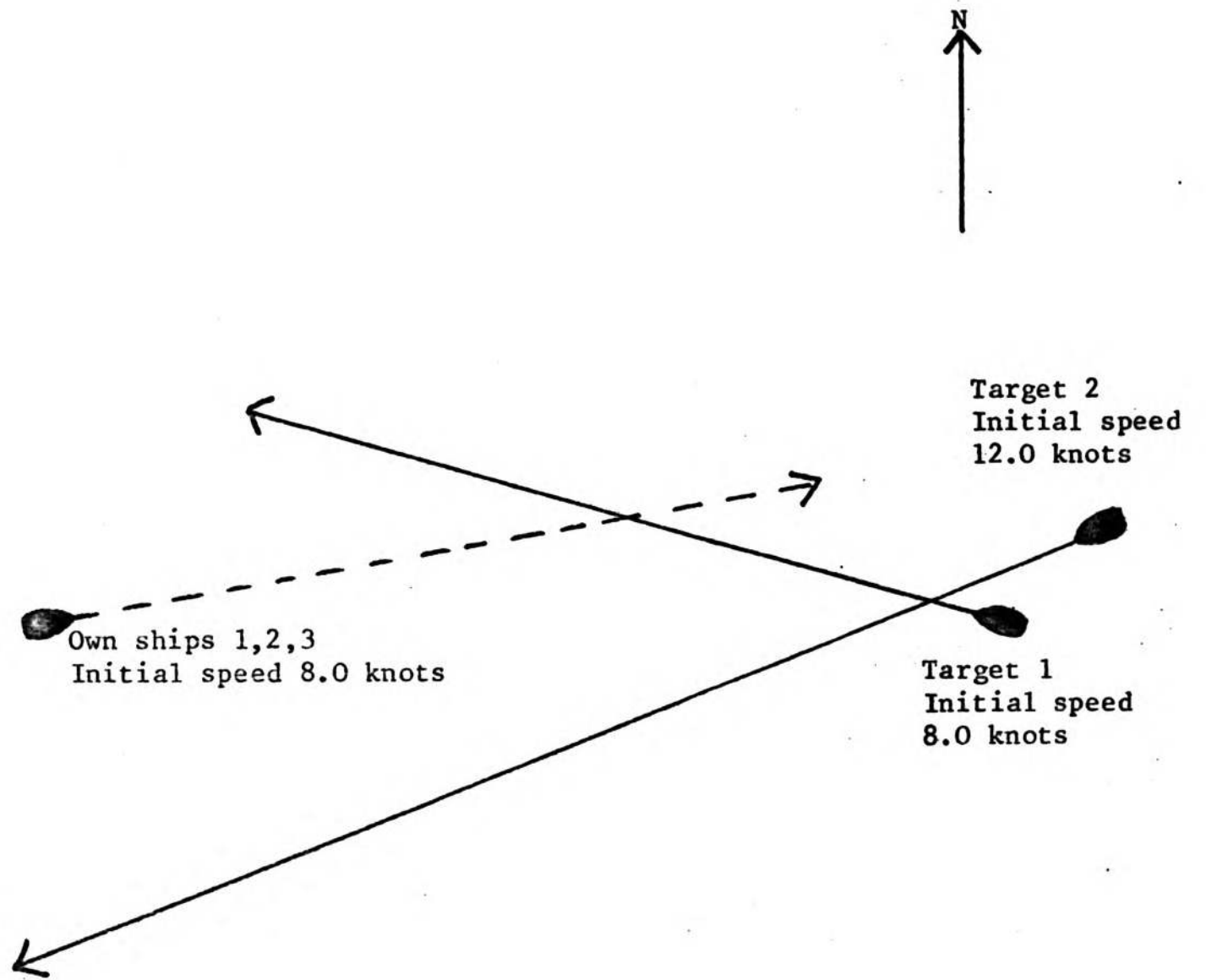

Scale: $\frac{1}{2}$ " represents 1 nautical mile

FIG. III.4 Open Ocean: Exercise 5: Initial Situation

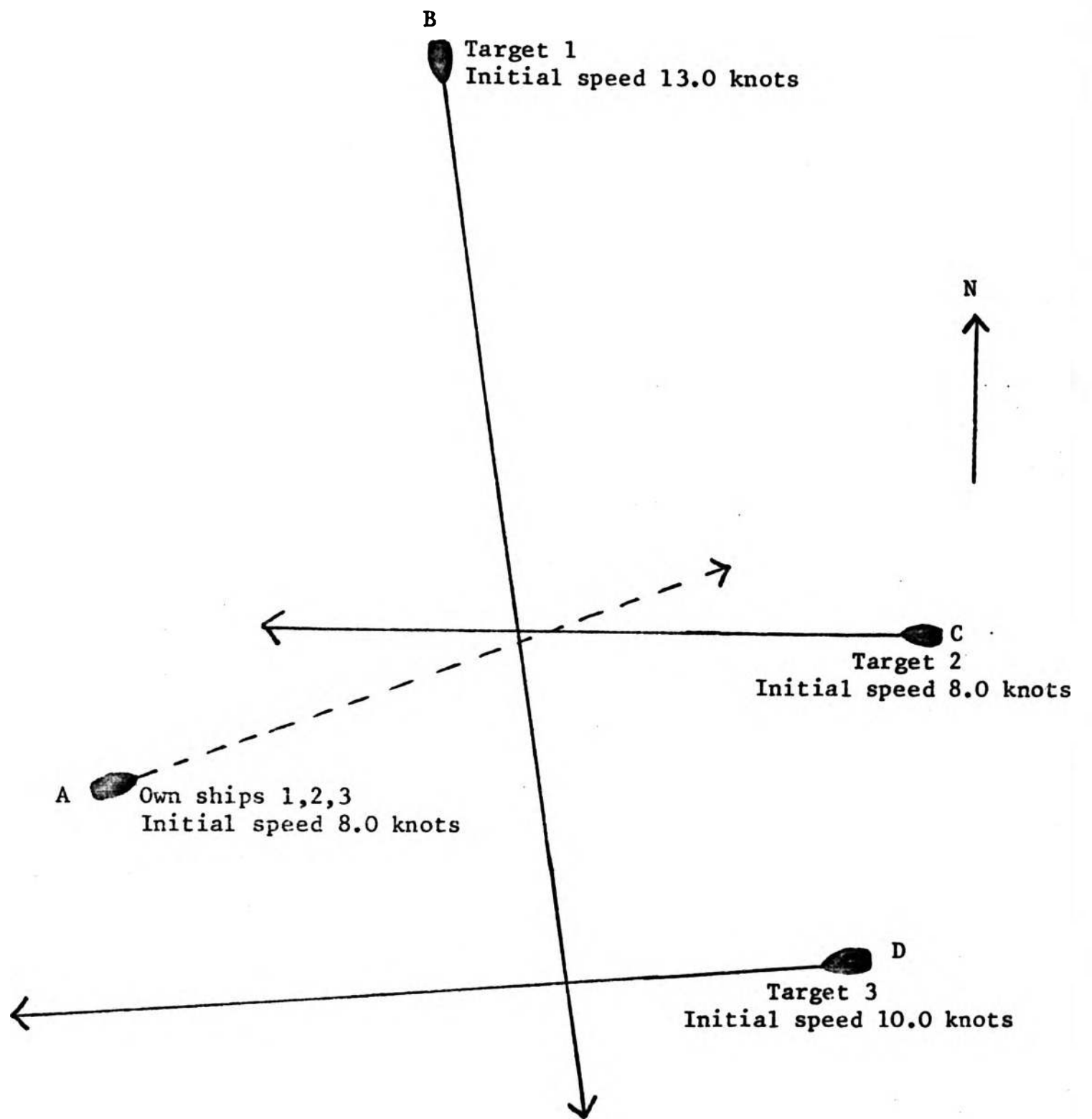

Scale: $\frac{1}{2}$ " represents 1 nautical mile

FIG. III.5 Open Ocean: Exercise 6: Initial Situation

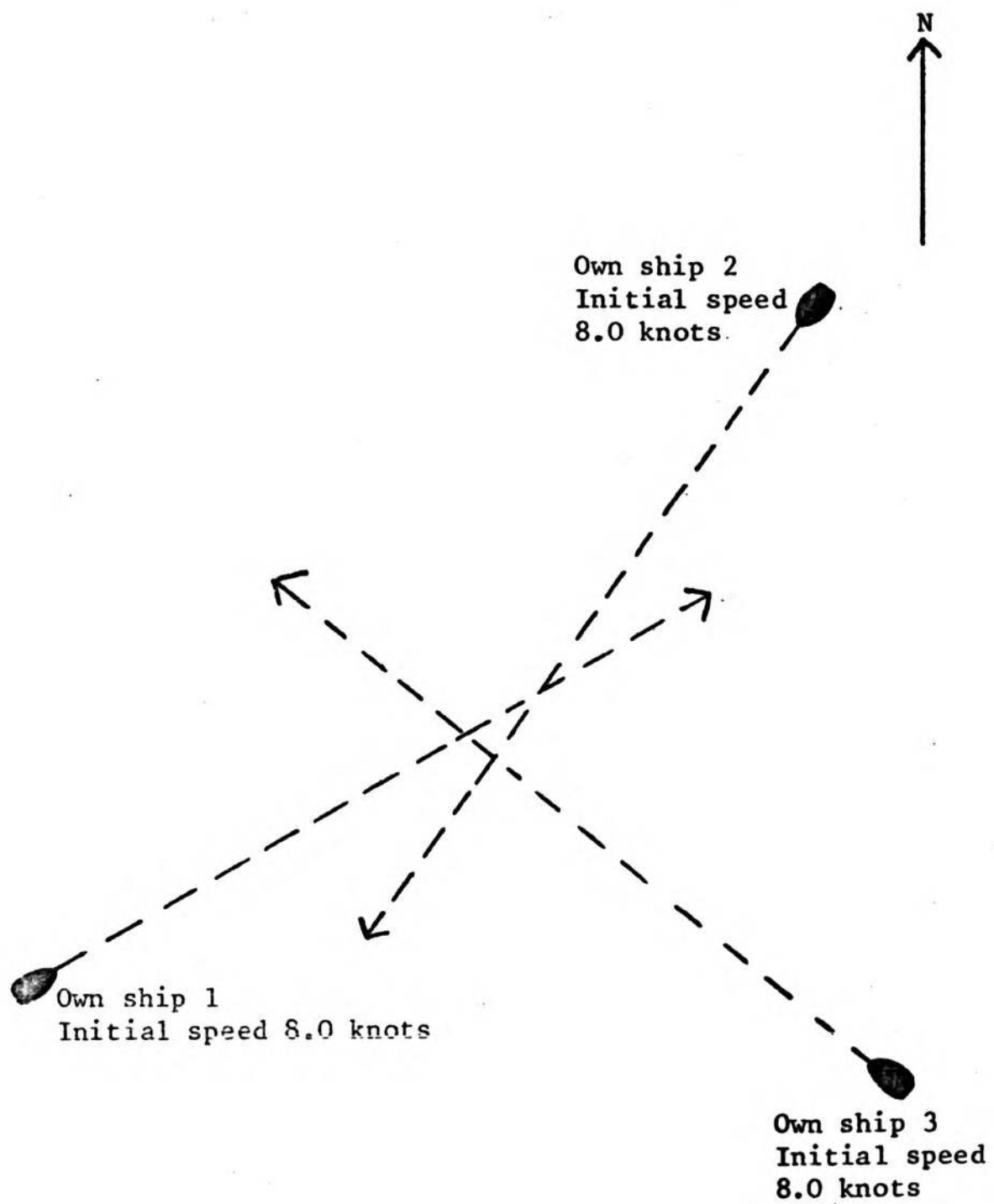

Scale: $\frac{1}{2}$ " represents 1 nautical mile

FIG. III.6 Open Ocean: Exercise 7: Initial Situation

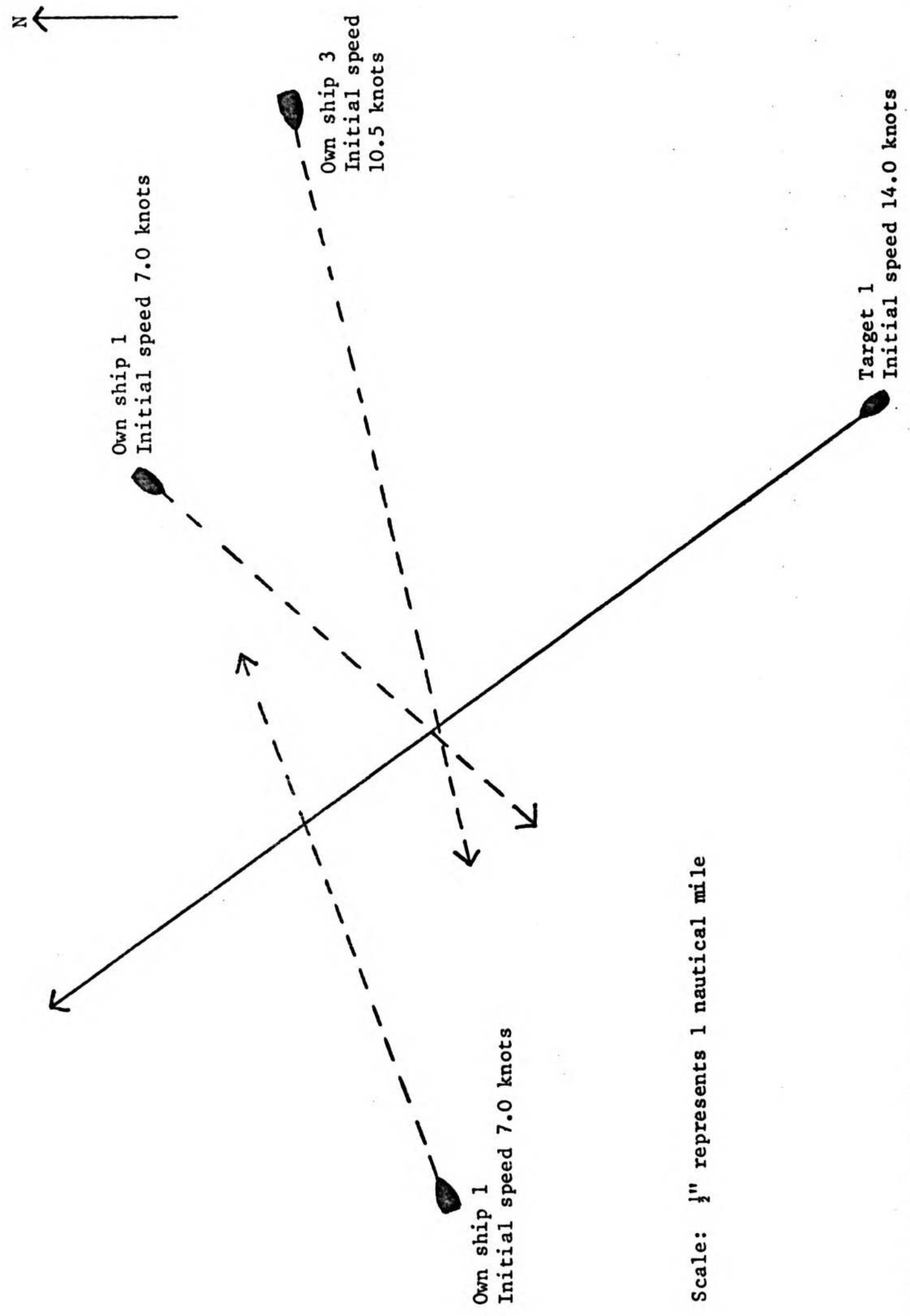
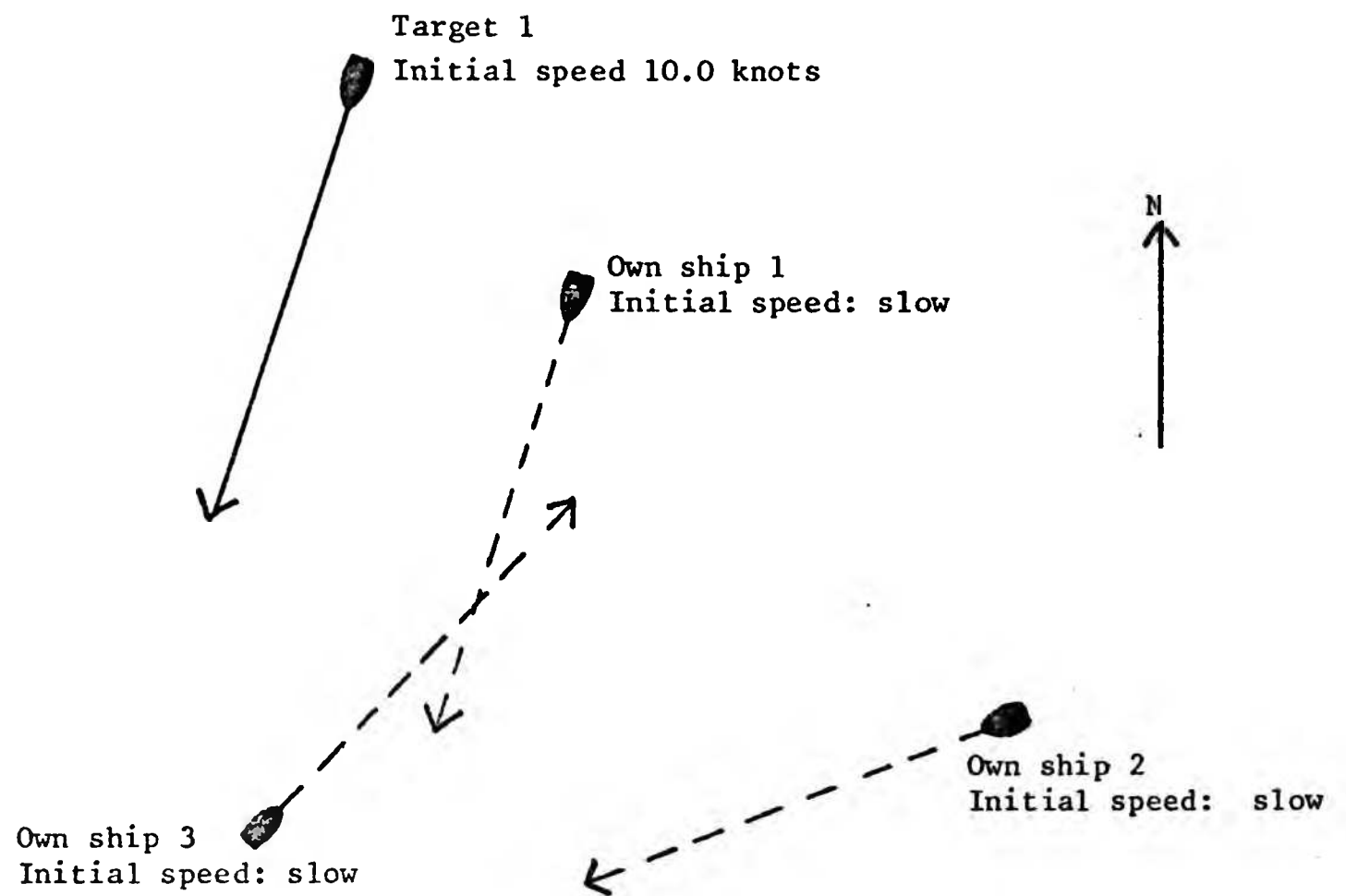

FIG. III.7 Open Ocean: Exercise 8: Initial Situation



Scale: $\frac{1}{2}$ " represents 1 nautical mile

FIG. III.8 Open Ocean: Exercise 16: Initial Situation

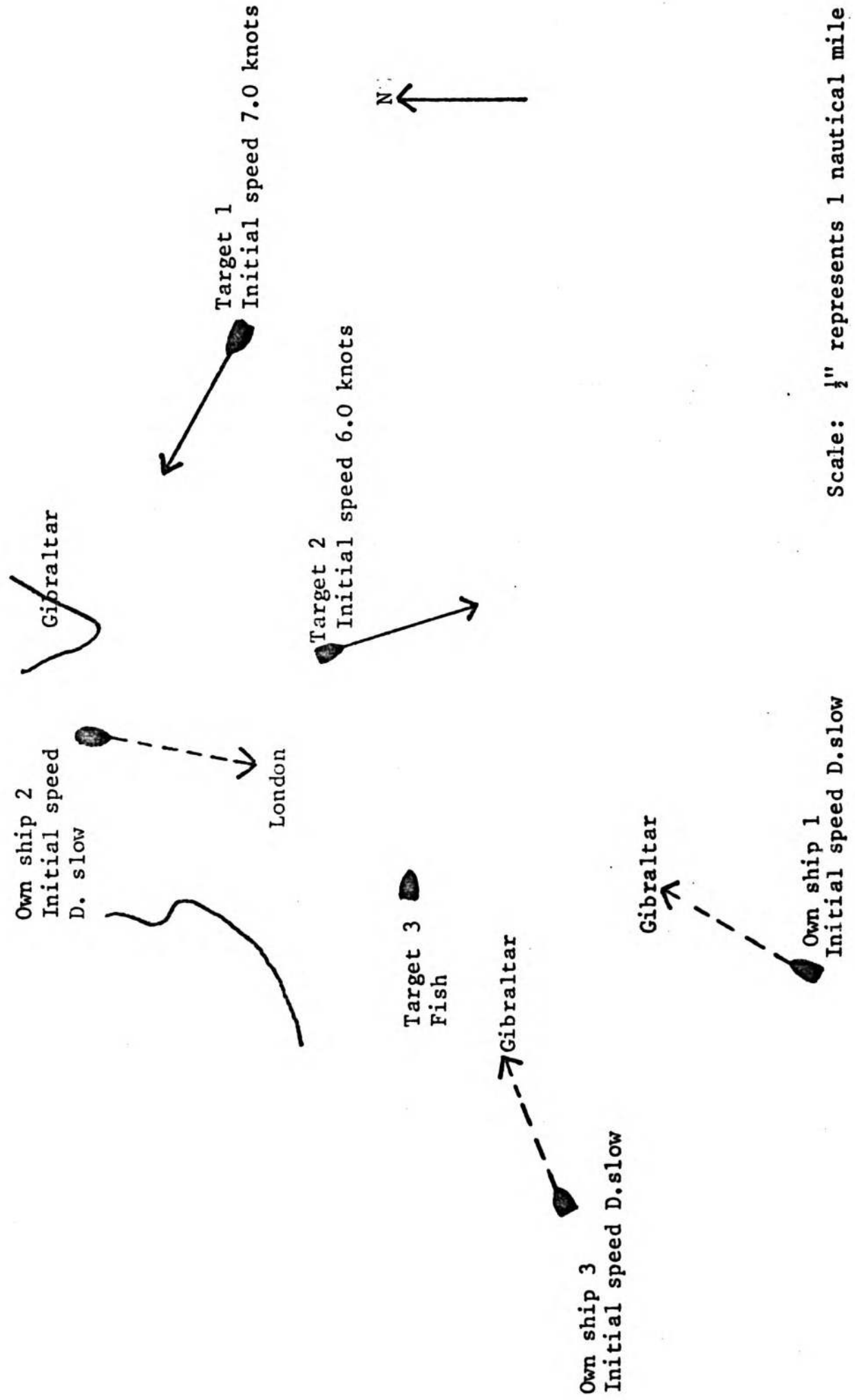
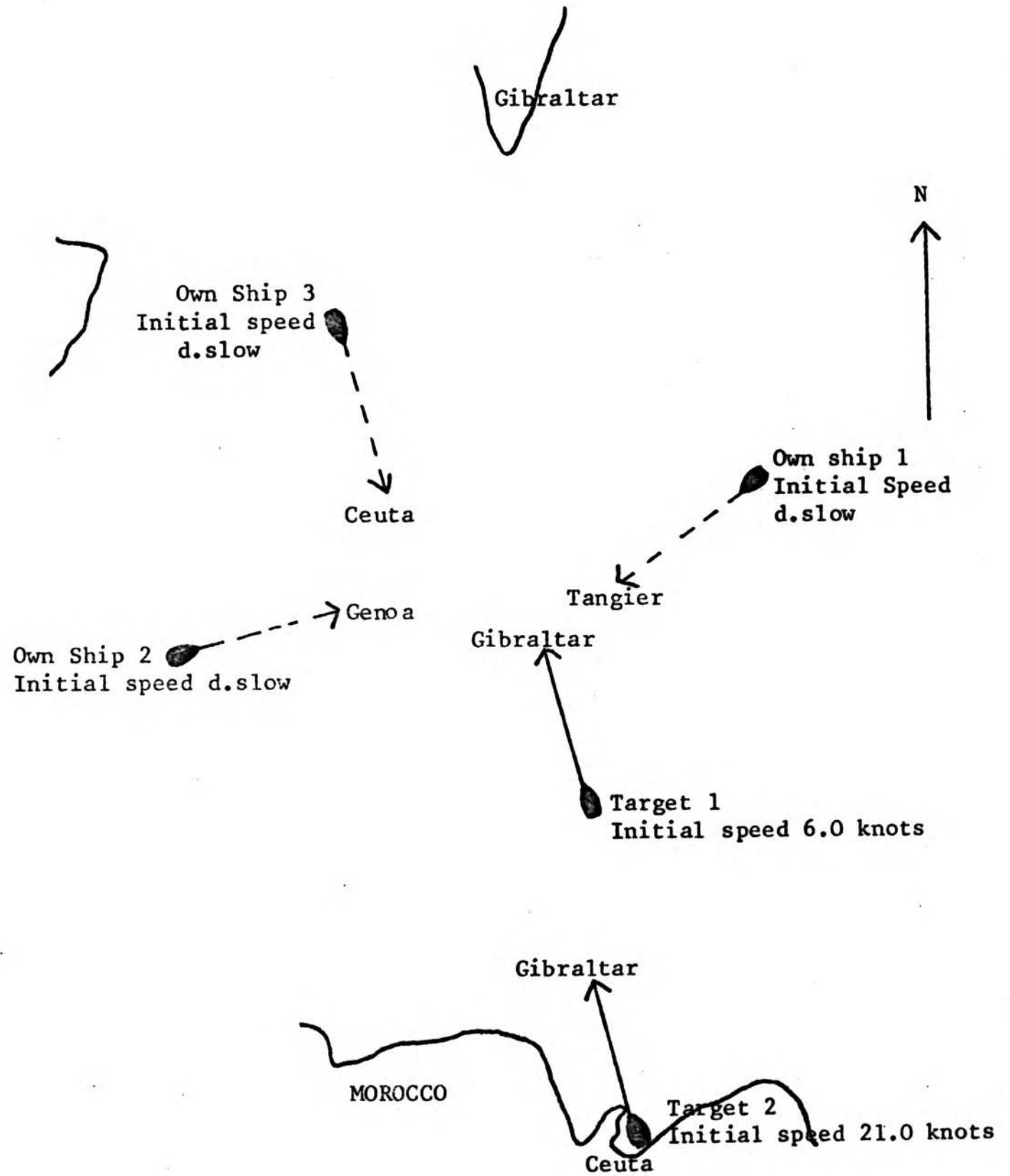
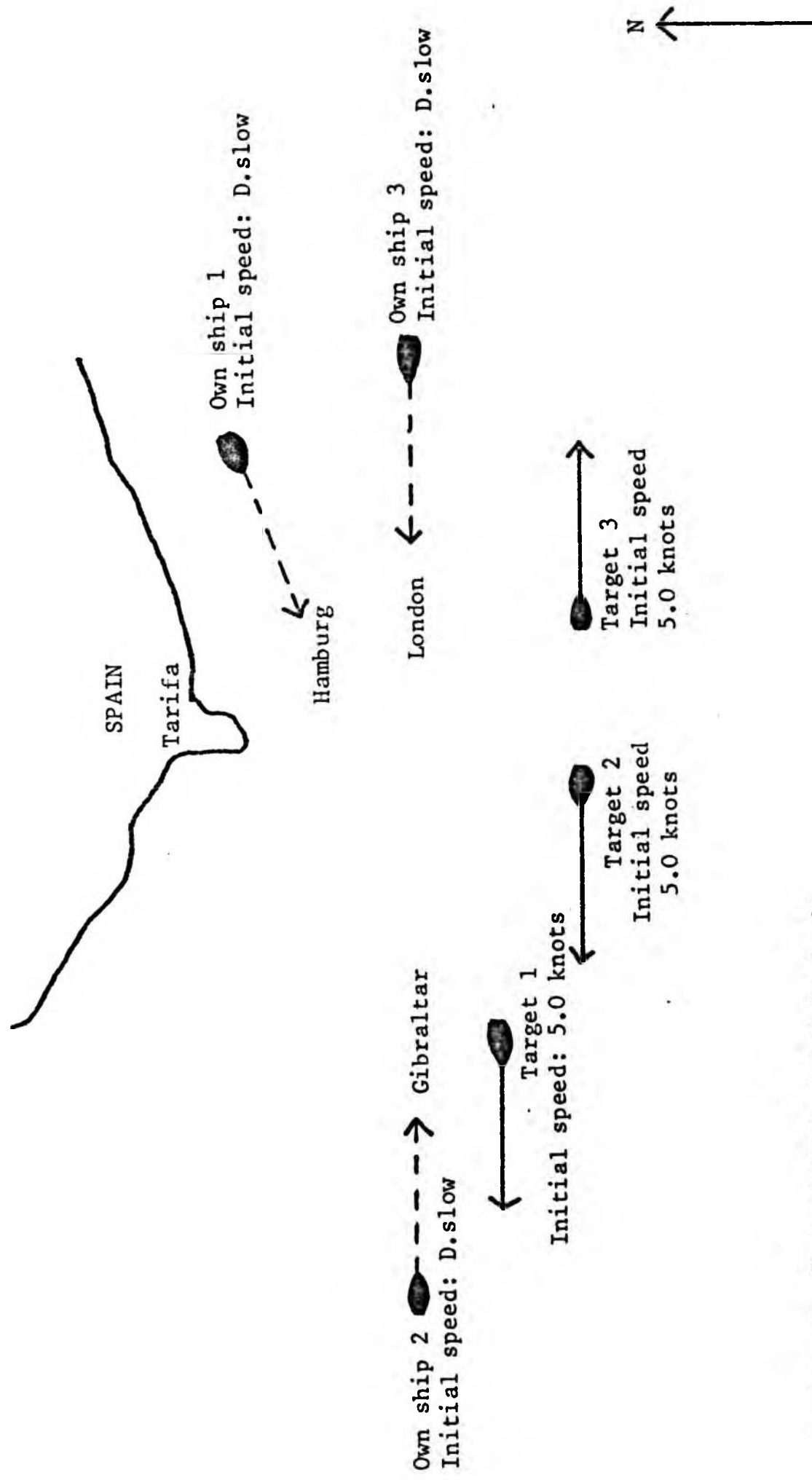

FIG. III.9 Gibraltar Strait: Exercise 9: Initial Situation



Scale: $\frac{1}{2}$ " represents 1 nautical mile

FIG. III.10 Gibraltar Strait: Exercise 10: Initial Situation



Scale: 1" represents 1 nautical mile

FIG. III.11 Gibraltar Strait: Exercise 11: Initial Situation

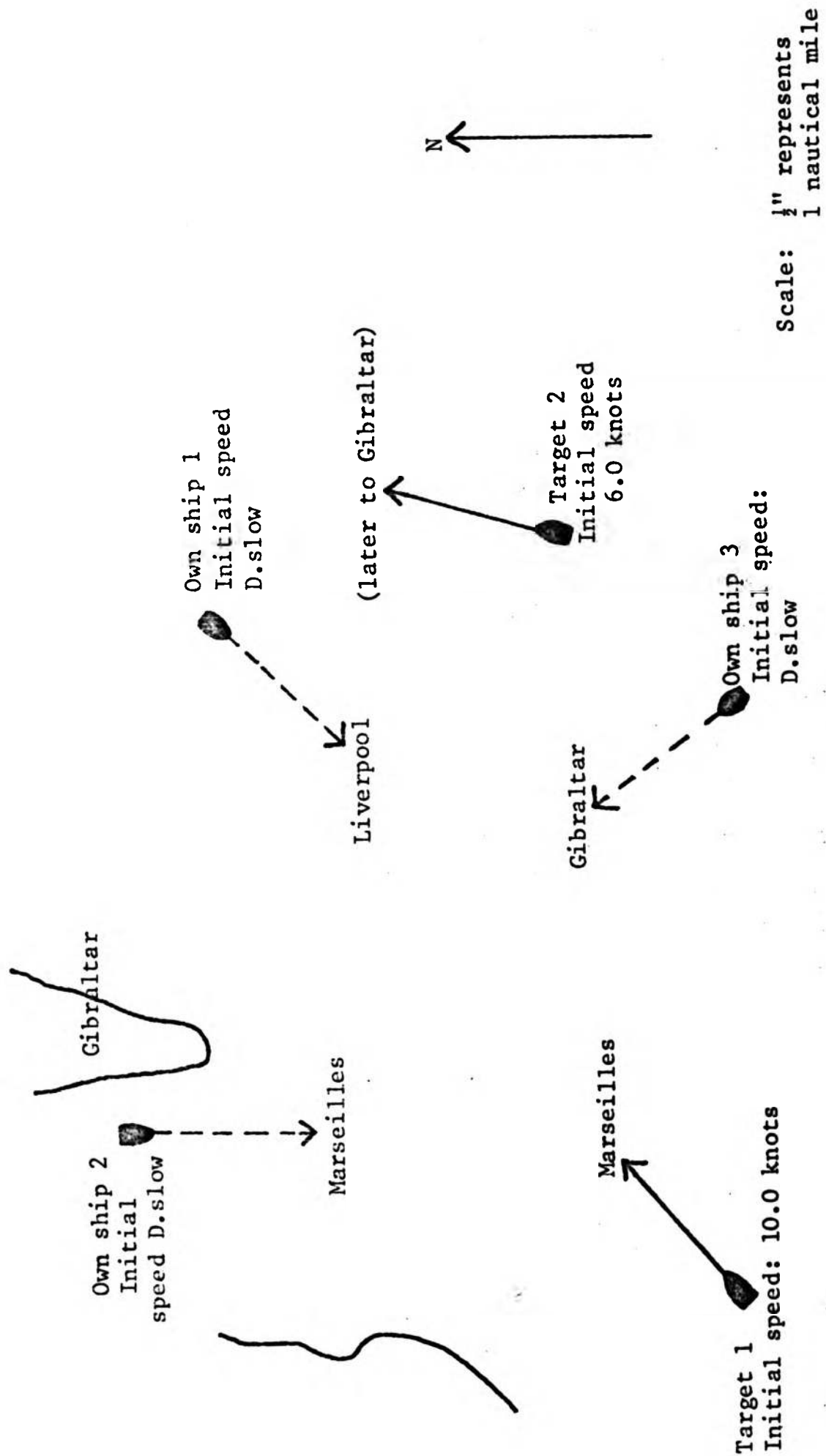

FIG. III.12 Gibraltar Strait: Exercise 12: Initial Situation

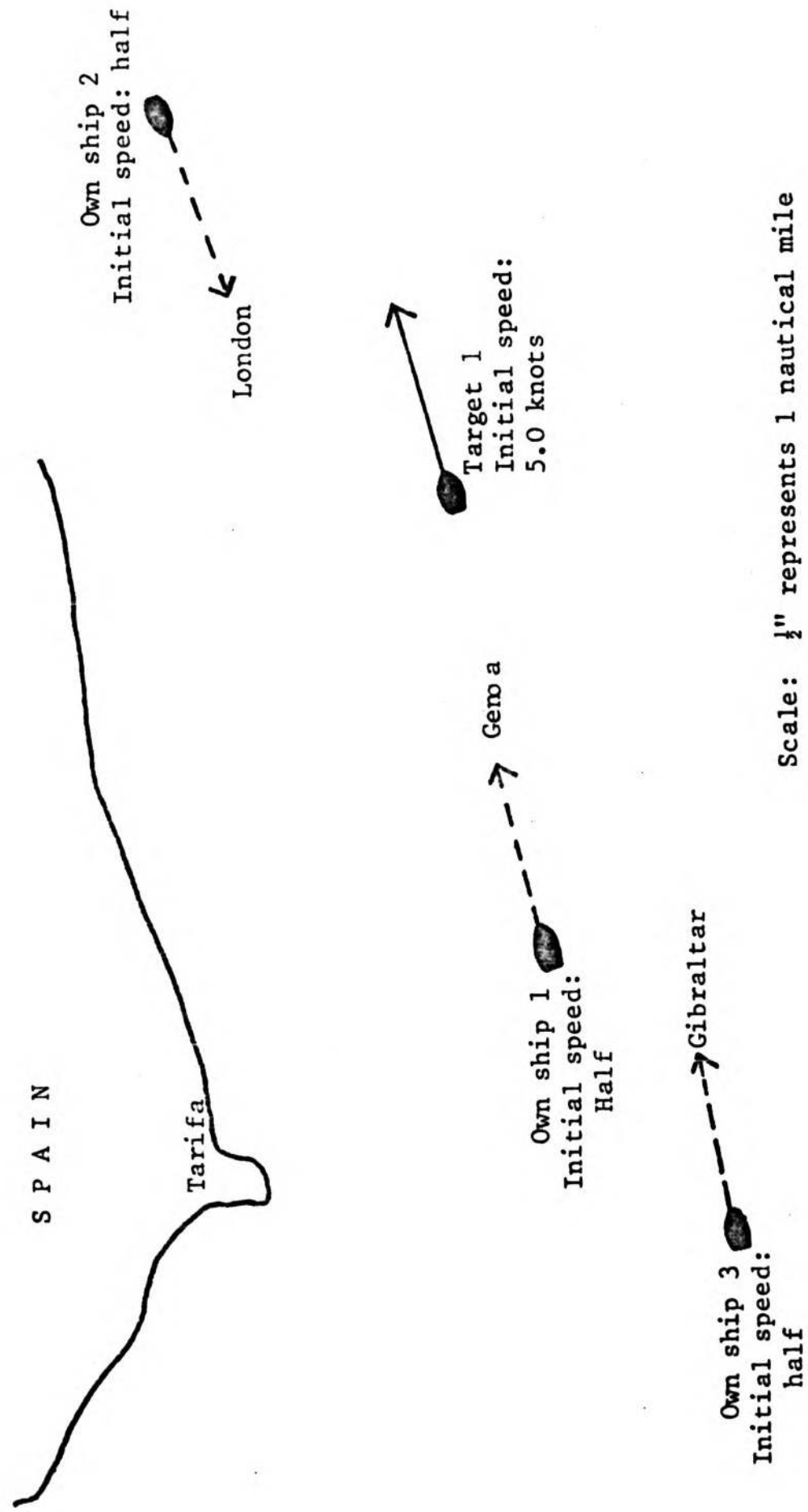
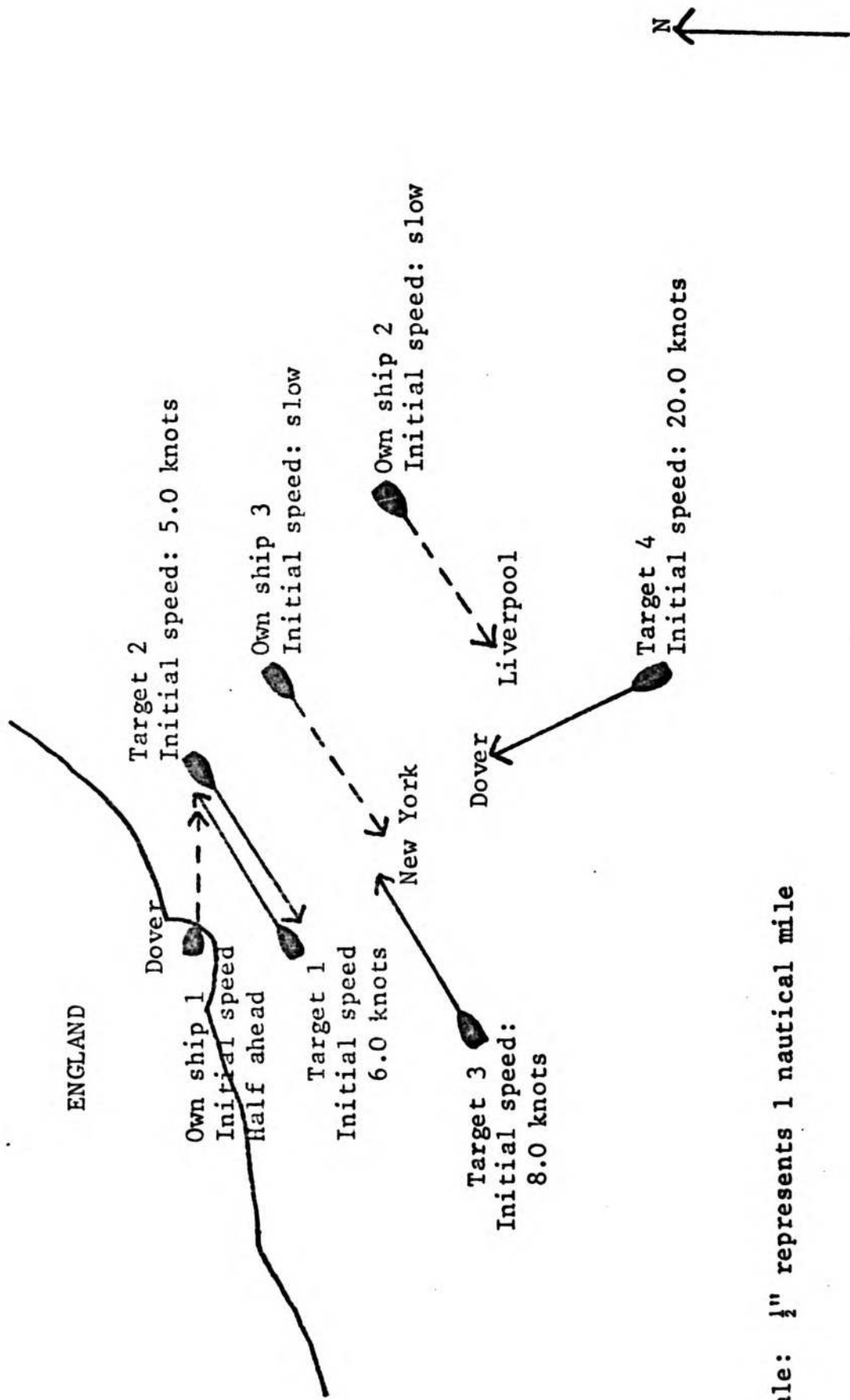

FIG. III.13 Gibraltar Strait: Exercise 13: Initial Situation

Target 2
Initial speed: 25.0 knots



Scale: 1/4" represents 1 nautical mile

FIG. III.14 Dover Strait: Exercise 18: Initial Situation

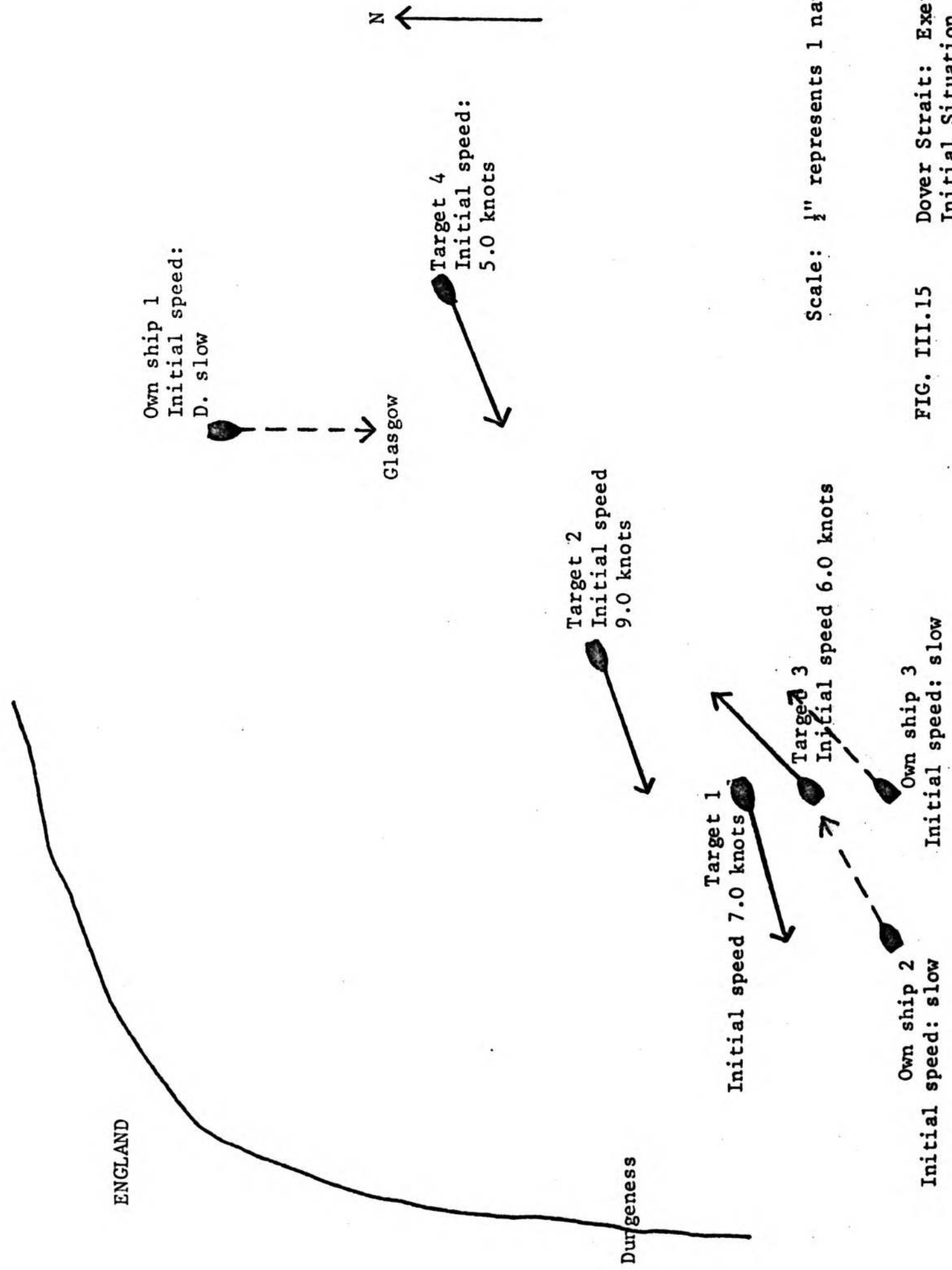

FIG. III.15 Dover Strait: Exercise 19: Initial Situation

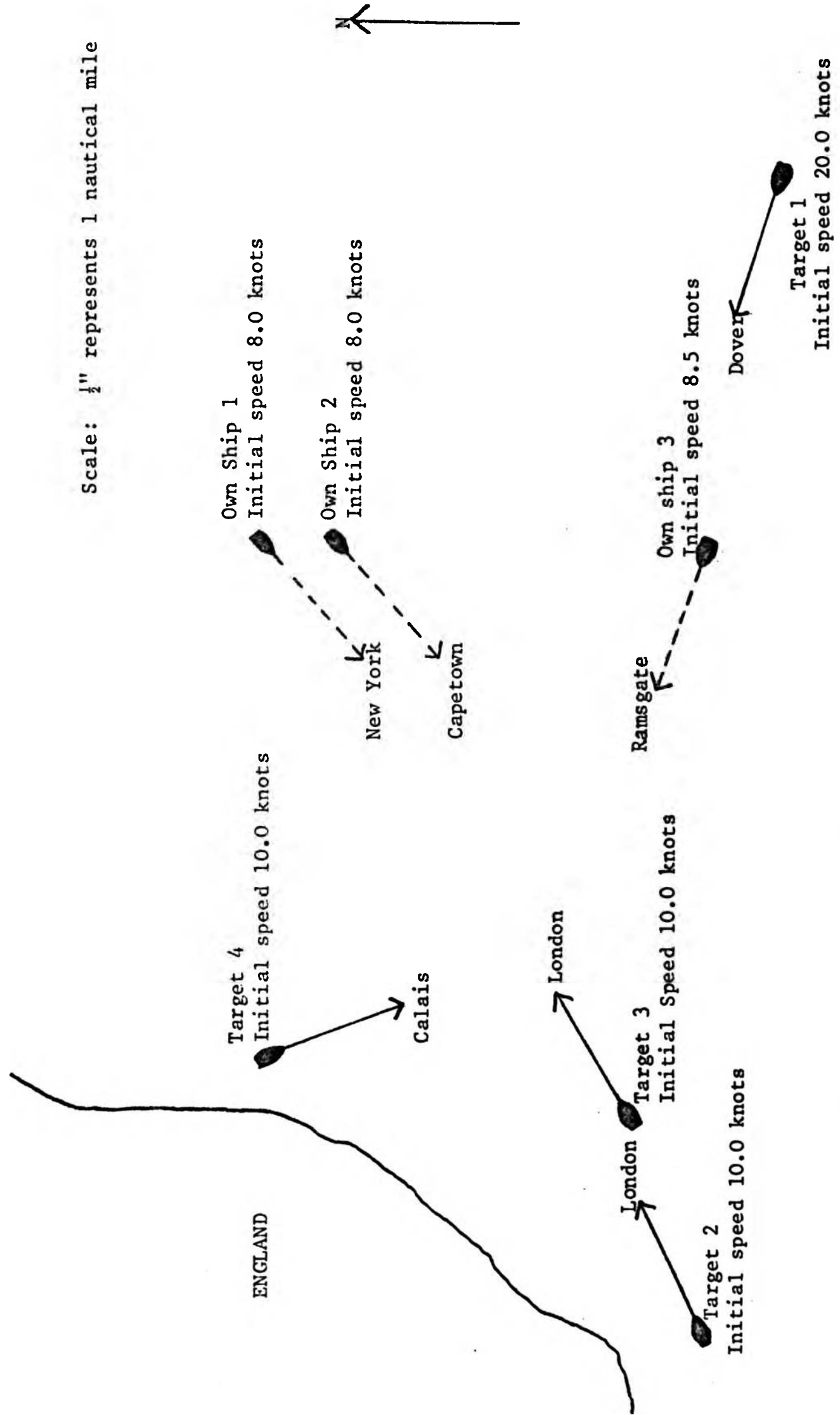

FIG. III.16 Dover Strait: Exercise 20: Initial Situation

APPENDIX III.III Sample Sizes by Type of Exercise: Simulator Data

| Type of Exercise | OPEN OCEAN | | | | | | | | GIBRALTAR | | | | DOVER | | | All Open Ocean | All Gibraltar | All Dover Strait | Total |
|----------------------------------|------------|-----|-----|-----|-----|-----|-----|-----|-----------|-----|-----|-----|-------|-----|-----|----------------|---------------|------------------|-------|
| | 1 | 2 | 3 | 5 | 6 | 7 | 8 | 16 | 9 | 10 | 11 | 12 | 13 | 18 | 19 | | | | |
| Exercise Number | 1 | 2 | 3 | 5 | 6 | 7 | 8 | 16 | 9 | 10 | 11 | 12 | 13 | 18 | 19 | 20 | | | |
| Number of Times Recorded | 6 | 6 | 8 | 6 | 7 | 5 | 3 | 2 | 4 | 5 | 2 | 4 | 4 | 1 | 2 | 5 | 43 | 19 | 8 |
| Total Number of Own Ships | 18 | 17 | 24 | 16 | 21 | 15 | 9 | 6 | 12 | 15 | 6 | 12 | 12 | 3 | 6 | 15 | 126 | 57 | 24 |
| Total Number of Target Ships | 6 | 6 | 6 | 12 | 21 | 0 | 3 | 2 | 12 | 12 | 8 | 13 | 10 | 4 | 8 | 21 | 66 | 55 | 33 |
| Total Number of Minutes Recorded | 216 | 252 | 420 | 258 | 324 | 216 | 168 | 90 | 216 | 240 | 84 | 186 | 168 | 42 | 102 | 240 | 1944 | 894 | 384 |
| Total Number of Points | 126 | 136 | 468 | 250 | 549 | 246 | 279 | 153 | 609 | 594 | 288 | 552 | 108 | 144 | 342 | 843 | 2207 | 2151 | 1329 |

TABLE III.1 Sample Sizes by Type of Exercise: Simulator Data

APPENDIX III.IV

III.IV Navigational Charts of the Sunk Survey Area

- p.225 Fig. III.17 England - East coast:
North Foreland to Orford Ness including
the entrance to the Thames.
- p.226 Fig. III.18 England - East coast:
The Naze to Orford Ness



| SOUNDINGS | |
|-----------|-----|
| 1 | 1 |
| 2 | 2 |
| 3 | 3 |
| 4 | 4 |
| 5 | 5 |
| 6 | 6 |
| 7 | 7 |
| 8 | 8 |
| 9 | 9 |
| 10 | 10 |
| 11 | 11 |
| 12 | 12 |
| 13 | 13 |
| 14 | 14 |
| 15 | 15 |
| 16 | 16 |
| 17 | 17 |
| 18 | 18 |
| 19 | 19 |
| 20 | 20 |
| 21 | 21 |
| 22 | 22 |
| 23 | 23 |
| 24 | 24 |
| 25 | 25 |
| 26 | 26 |
| 27 | 27 |
| 28 | 28 |
| 29 | 29 |
| 30 | 30 |
| 31 | 31 |
| 32 | 32 |
| 33 | 33 |
| 34 | 34 |
| 35 | 35 |
| 36 | 36 |
| 37 | 37 |
| 38 | 38 |
| 39 | 39 |
| 40 | 40 |
| 41 | 41 |
| 42 | 42 |
| 43 | 43 |
| 44 | 44 |
| 45 | 45 |
| 46 | 46 |
| 47 | 47 |
| 48 | 48 |
| 49 | 49 |
| 50 | 50 |
| 51 | 51 |
| 52 | 52 |
| 53 | 53 |
| 54 | 54 |
| 55 | 55 |
| 56 | 56 |
| 57 | 57 |
| 58 | 58 |
| 59 | 59 |
| 60 | 60 |
| 61 | 61 |
| 62 | 62 |
| 63 | 63 |
| 64 | 64 |
| 65 | 65 |
| 66 | 66 |
| 67 | 67 |
| 68 | 68 |
| 69 | 69 |
| 70 | 70 |
| 71 | 71 |
| 72 | 72 |
| 73 | 73 |
| 74 | 74 |
| 75 | 75 |
| 76 | 76 |
| 77 | 77 |
| 78 | 78 |
| 79 | 79 |
| 80 | 80 |
| 81 | 81 |
| 82 | 82 |
| 83 | 83 |
| 84 | 84 |
| 85 | 85 |
| 86 | 86 |
| 87 | 87 |
| 88 | 88 |
| 89 | 89 |
| 90 | 90 |
| 91 | 91 |
| 92 | 92 |
| 93 | 93 |
| 94 | 94 |
| 95 | 95 |
| 96 | 96 |
| 97 | 97 |
| 98 | 98 |
| 99 | 99 |
| 100 | 100 |

NORTH FORELAND TO ORFORDNESS
ENTRANCE TO THE THAMES

From the Admiralty Hydrographic Office, London.
Scale of the Chart, 1:50,000.
Published by the Admiralty, London.
© 1914.

| SOUNDINGS | |
|-----------|-----|
| 1 | 1 |
| 2 | 2 |
| 3 | 3 |
| 4 | 4 |
| 5 | 5 |
| 6 | 6 |
| 7 | 7 |
| 8 | 8 |
| 9 | 9 |
| 10 | 10 |
| 11 | 11 |
| 12 | 12 |
| 13 | 13 |
| 14 | 14 |
| 15 | 15 |
| 16 | 16 |
| 17 | 17 |
| 18 | 18 |
| 19 | 19 |
| 20 | 20 |
| 21 | 21 |
| 22 | 22 |
| 23 | 23 |
| 24 | 24 |
| 25 | 25 |
| 26 | 26 |
| 27 | 27 |
| 28 | 28 |
| 29 | 29 |
| 30 | 30 |
| 31 | 31 |
| 32 | 32 |
| 33 | 33 |
| 34 | 34 |
| 35 | 35 |
| 36 | 36 |
| 37 | 37 |
| 38 | 38 |
| 39 | 39 |
| 40 | 40 |
| 41 | 41 |
| 42 | 42 |
| 43 | 43 |
| 44 | 44 |
| 45 | 45 |
| 46 | 46 |
| 47 | 47 |
| 48 | 48 |
| 49 | 49 |
| 50 | 50 |
| 51 | 51 |
| 52 | 52 |
| 53 | 53 |
| 54 | 54 |
| 55 | 55 |
| 56 | 56 |
| 57 | 57 |
| 58 | 58 |
| 59 | 59 |
| 60 | 60 |
| 61 | 61 |
| 62 | 62 |
| 63 | 63 |
| 64 | 64 |
| 65 | 65 |
| 66 | 66 |
| 67 | 67 |
| 68 | 68 |
| 69 | 69 |
| 70 | 70 |
| 71 | 71 |
| 72 | 72 |
| 73 | 73 |
| 74 | 74 |
| 75 | 75 |
| 76 | 76 |
| 77 | 77 |
| 78 | 78 |
| 79 | 79 |
| 80 | 80 |
| 81 | 81 |
| 82 | 82 |
| 83 | 83 |
| 84 | 84 |
| 85 | 85 |
| 86 | 86 |
| 87 | 87 |
| 88 | 88 |
| 89 | 89 |
| 90 | 90 |
| 91 | 91 |
| 92 | 92 |
| 93 | 93 |
| 94 | 94 |
| 95 | 95 |
| 96 | 96 |
| 97 | 97 |
| 98 | 98 |
| 99 | 99 |
| 100 | 100 |

| SOUNDINGS | |
|-----------|-----|
| 1 | 1 |
| 2 | 2 |
| 3 | 3 |
| 4 | 4 |
| 5 | 5 |
| 6 | 6 |
| 7 | 7 |
| 8 | 8 |
| 9 | 9 |
| 10 | 10 |
| 11 | 11 |
| 12 | 12 |
| 13 | 13 |
| 14 | 14 |
| 15 | 15 |
| 16 | 16 |
| 17 | 17 |
| 18 | 18 |
| 19 | 19 |
| 20 | 20 |
| 21 | 21 |
| 22 | 22 |
| 23 | 23 |
| 24 | 24 |
| 25 | 25 |
| 26 | 26 |
| 27 | 27 |
| 28 | 28 |
| 29 | 29 |
| 30 | 30 |
| 31 | 31 |
| 32 | 32 |
| 33 | 33 |
| 34 | 34 |
| 35 | 35 |
| 36 | 36 |
| 37 | 37 |
| 38 | 38 |
| 39 | 39 |
| 40 | 40 |
| 41 | 41 |
| 42 | 42 |
| 43 | 43 |
| 44 | 44 |
| 45 | 45 |
| 46 | 46 |
| 47 | 47 |
| 48 | 48 |
| 49 | 49 |
| 50 | 50 |
| 51 | 51 |
| 52 | 52 |
| 53 | 53 |
| 54 | 54 |
| 55 | 55 |
| 56 | 56 |
| 57 | 57 |
| 58 | 58 |
| 59 | 59 |
| 60 | 60 |
| 61 | 61 |
| 62 | 62 |
| 63 | 63 |
| 64 | 64 |
| 65 | 65 |
| 66 | 66 |
| 67 | 67 |
| 68 | 68 |
| 69 | 69 |
| 70 | 70 |
| 71 | 71 |
| 72 | 72 |
| 73 | 73 |
| 74 | 74 |
| 75 | 75 |
| 76 | 76 |
| 77 | 77 |
| 78 | 78 |
| 79 | 79 |
| 80 | 80 |
| 81 | 81 |
| 82 | 82 |
| 83 | 83 |
| 84 | 84 |
| 85 | 85 |
| 86 | 86 |
| 87 | 87 |
| 88 | 88 |
| 89 | 89 |
| 90 | 90 |
| 91 | 91 |
| 92 | 92 |
| 93 | 93 |
| 94 | 94 |
| 95 | 95 |
| 96 | 96 |
| 97 | 97 |
| 98 | 98 |
| 99 | 99 |
| 100 | 100 |

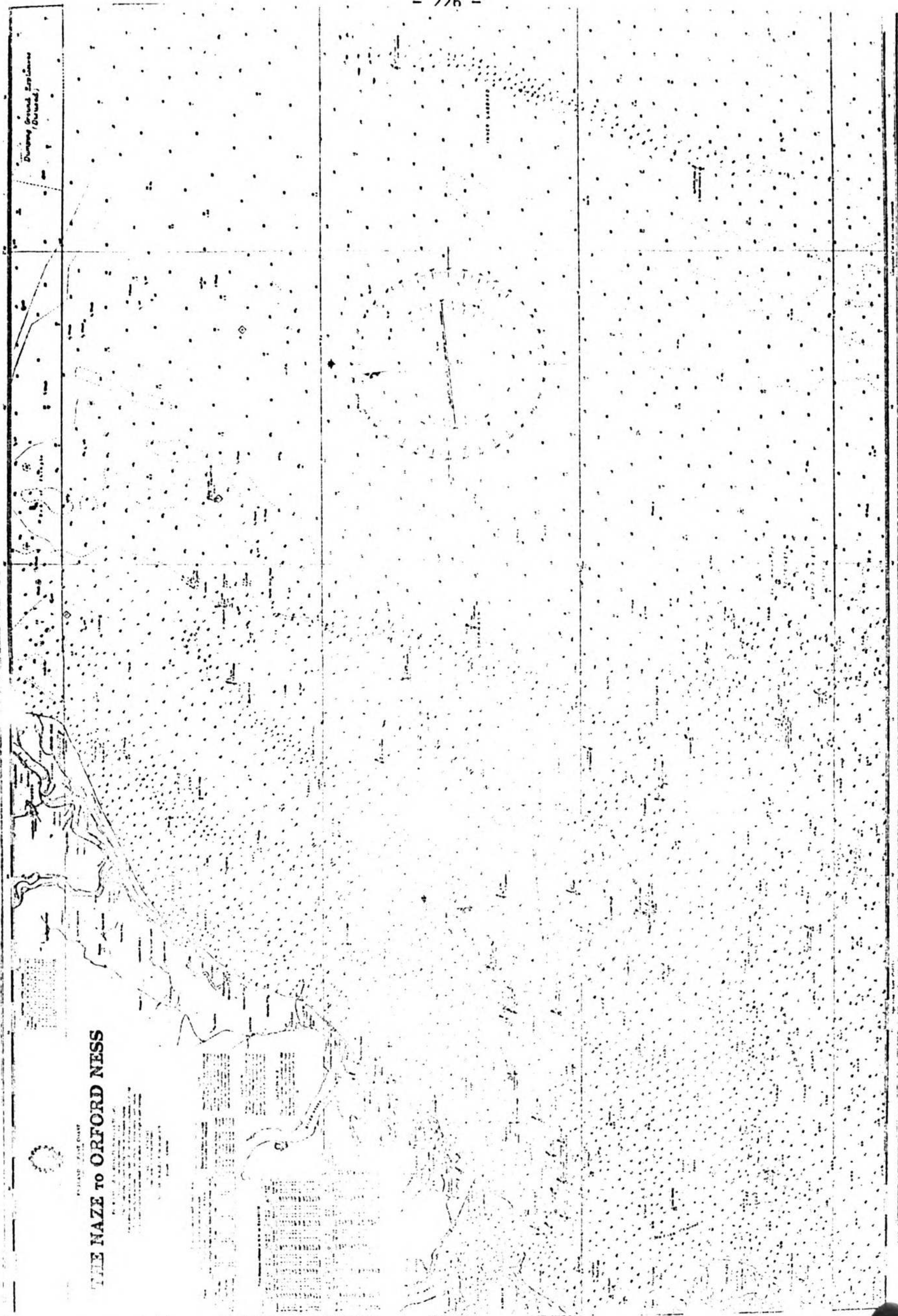

DUNNETT SOUND, EASTWARD

THE NAZE TO ORFORD NESS

FOURTEEN INCHES TO ONE MILE

APPENDIX III.V

MARCONI RADIO-LOCATOR 16

Marine radar of 3 cm wavelength.

Transmitter Peak Power 25 Kilowatts

Pulse length on Long Range 0.30 microseconds

Past repetition frequency (PRF) on Long Range 1000 pulses per second

Horizontal Beam Width 0.55°

Aerial Type and Size SWG
2.44 metres

PPI Diameter 406 mm (16")

APPENDIX III.VI

Equipment

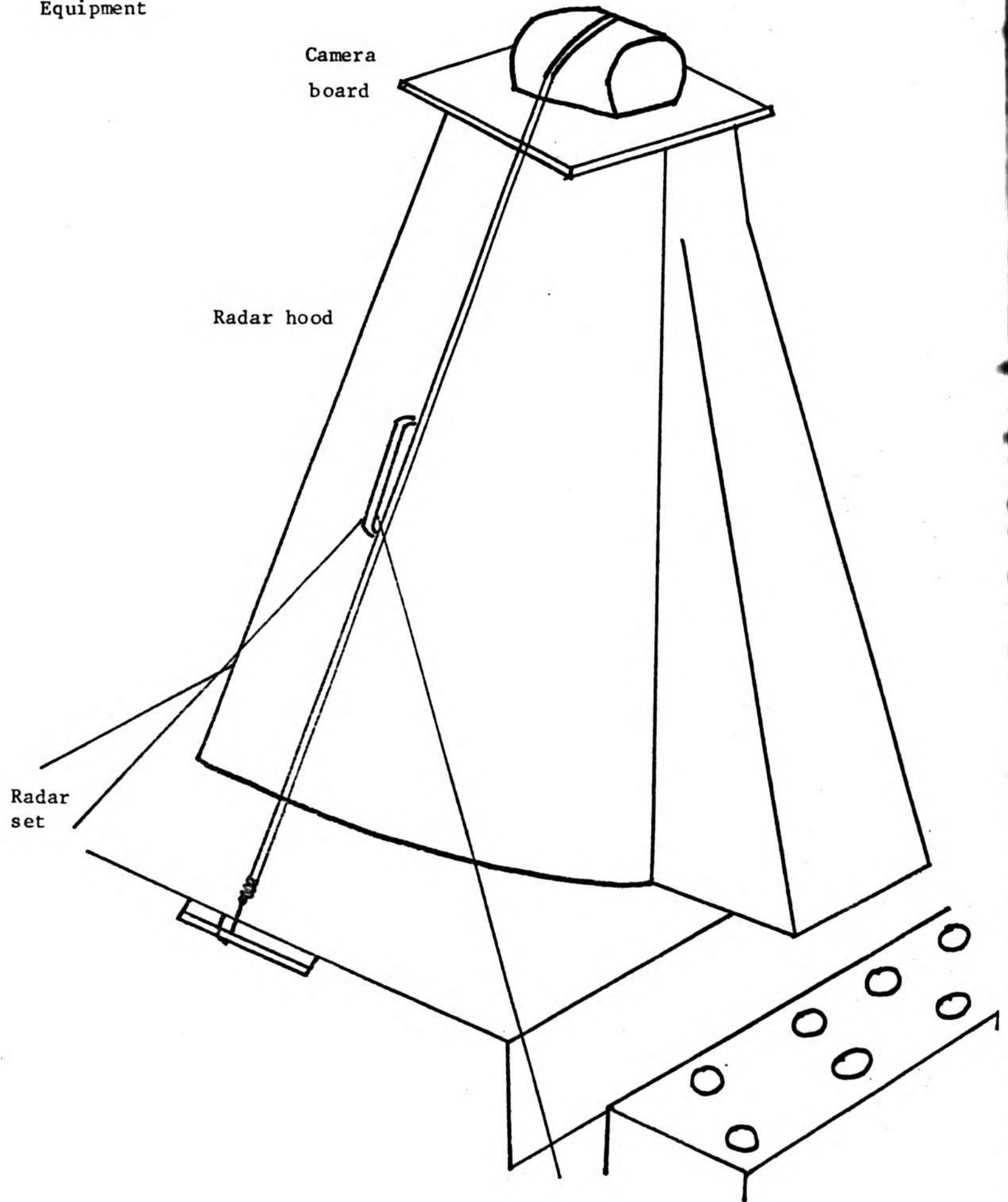

FIG. III.VI The set up of the Camera over the Radar Screen

APPENDIX III.VI

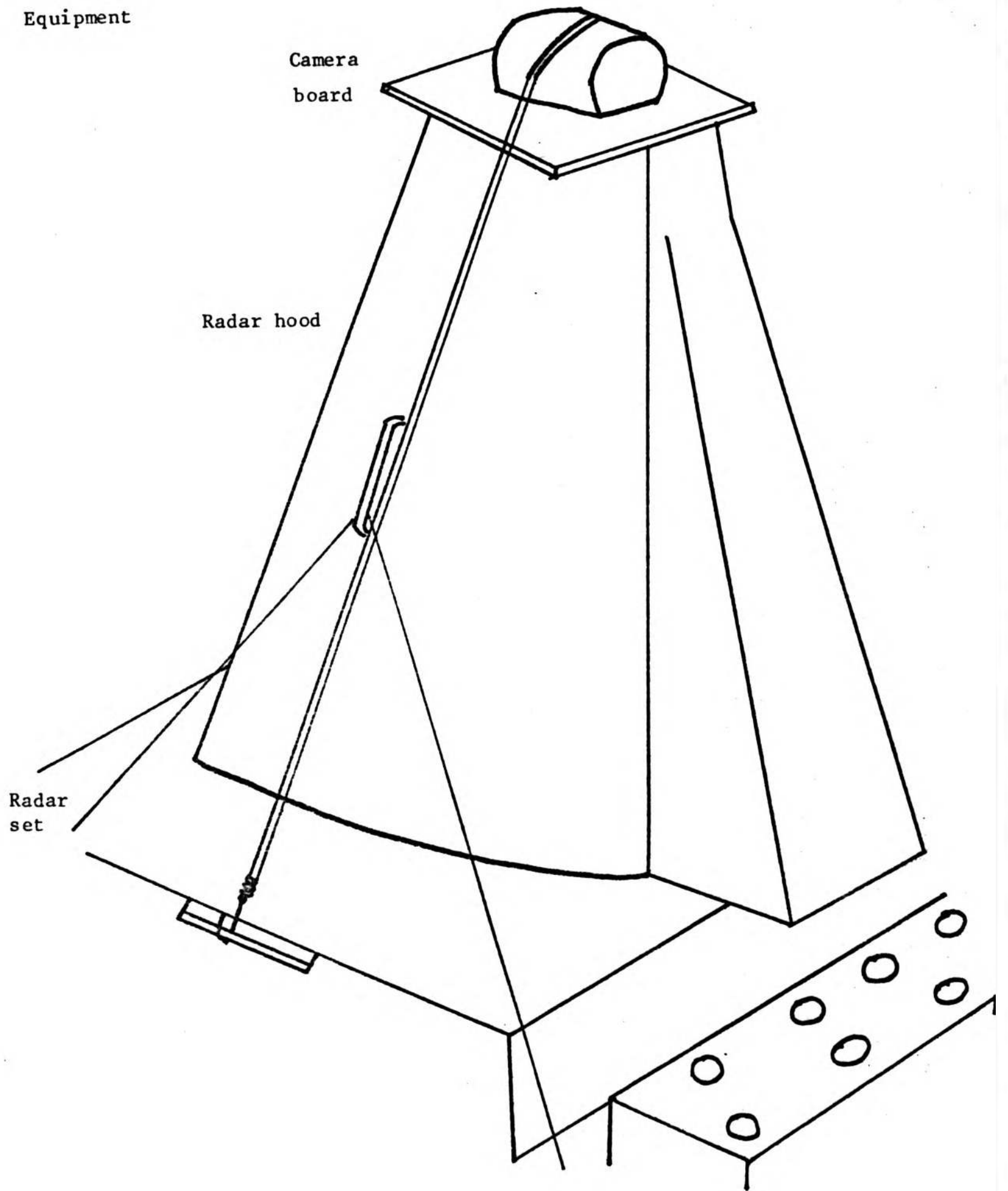

FIG. III.VI The set up of the Camera over the Radar Screen

APPENDIX III.VII

DIFFICULTIES IN USING RADAR PHOTOGRAPHS

A very brief description of the type of problems that were encountered in the use of the radar was given on page 46. This is enlarged upon in the following section but for a completely full account, reference should be made to the Institute of Navigation's handbook on marine radar⁽⁴⁰⁾. The problems encountered were:

1. Radar interference.
2. Side-lobes.
3. Sea clutter.
4. Multiple echoes.
5. False or indirect echoes.

1. Radar Interference (mutual interference)

Interference patterns occur when there are several other radars in the vicinity of a ship, operating on the same or very slightly different past repetition frequencies (p.r.f.'s). This interference consists of a randomly moving pattern of very bright dots over the whole of the P.P.I. display. These dots are in fact the actual pulses transmitted by other ships. If two radars had identical p.r.f.'s the echo of the interfering pulse would always appear at the same range on each trace and thus would form a ring on the receiving P.P.I. At the other extreme when the p.r.f.'s are very much different, any interference would be in the form of random pips or echoes on the screen. The most usual noticeable interference occurs when the p.r.f.'s are slightly different, so the echoes appear at increasing or decreasing ranges on successive traces and show as spirals instead of a ring. The various examples of photographs from the surveys all contain interference patterns but they are very distinctive so caused few problems when plotting was taking place.

2. Side Lobes

In addition to the main horizontal beam or lobe from the radar aerial, which is made very narrow by the design of the reflector or scanner, there is an inevitable slight "spill-over" of radio energy at various angles on either side of this beam. These act as weak, subsidiary beams and are always present to some degree in any practical aerial and are known as "side-lobes". The effect is that the edges of the target are drawn out in an arc of a circle on both sides of the one echo. An example of this is given in Fig.III21. The main problems which it presents are firstly,



FIG. III.20 The M.V. 'Sir John Cass'

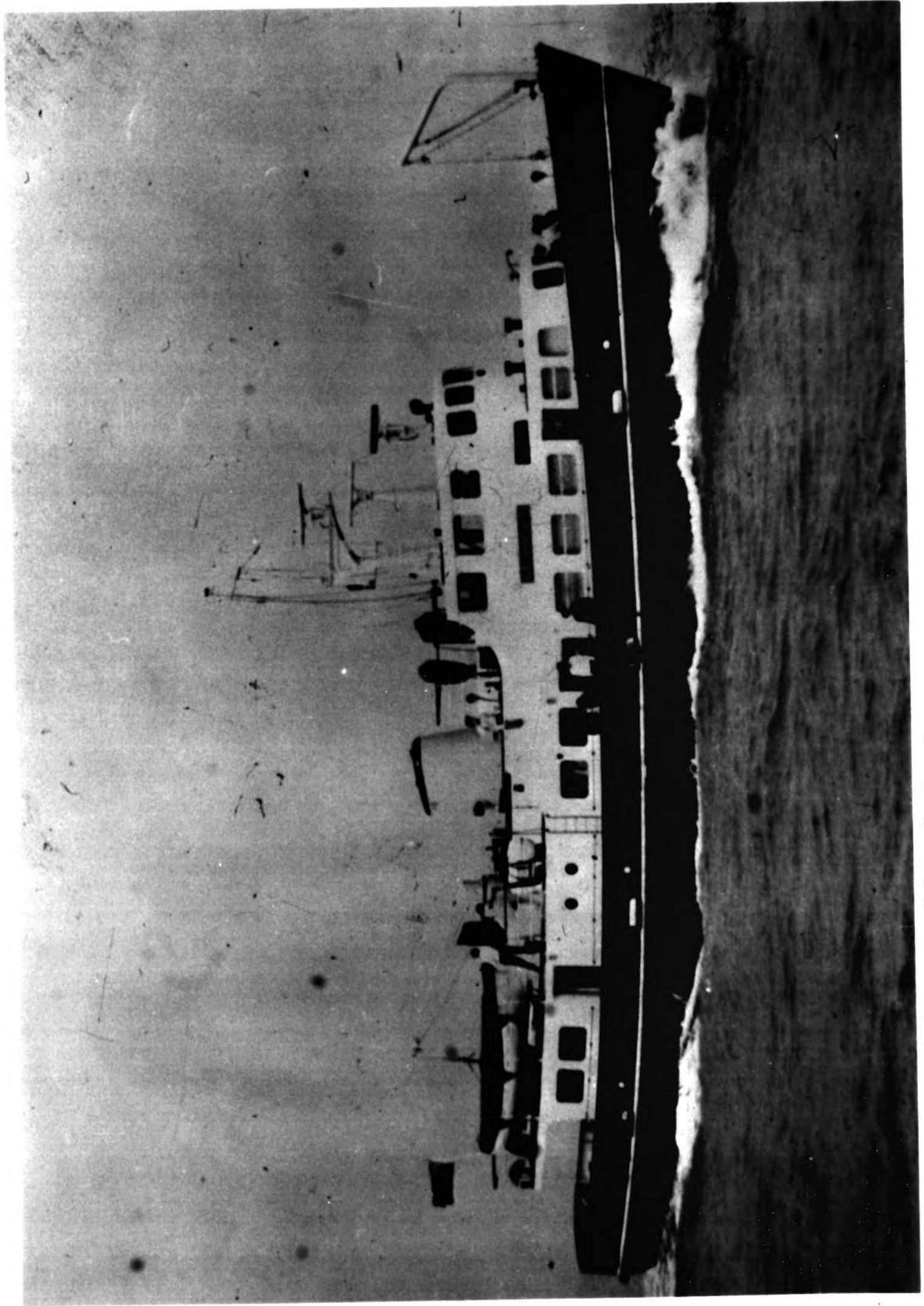

FIG. III.20 The M.V. 'Sir John Cass'

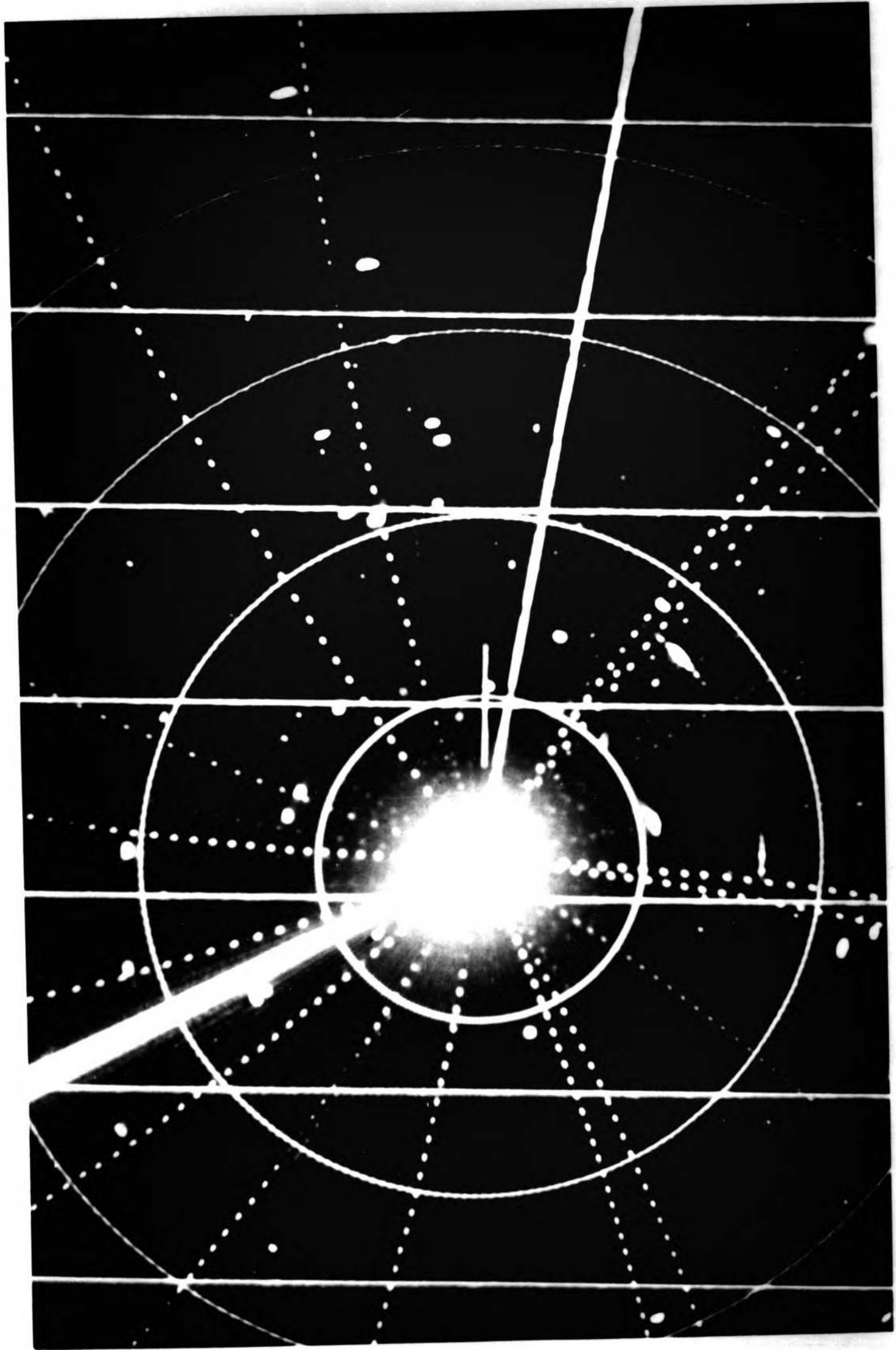

FIG. III.21 The Radar Picture at 0.42 on 21.5.72. Sunk Survey 1. (Light setting f5.6, exposure time 6 secs). This picture illustrates side-lobing effect.

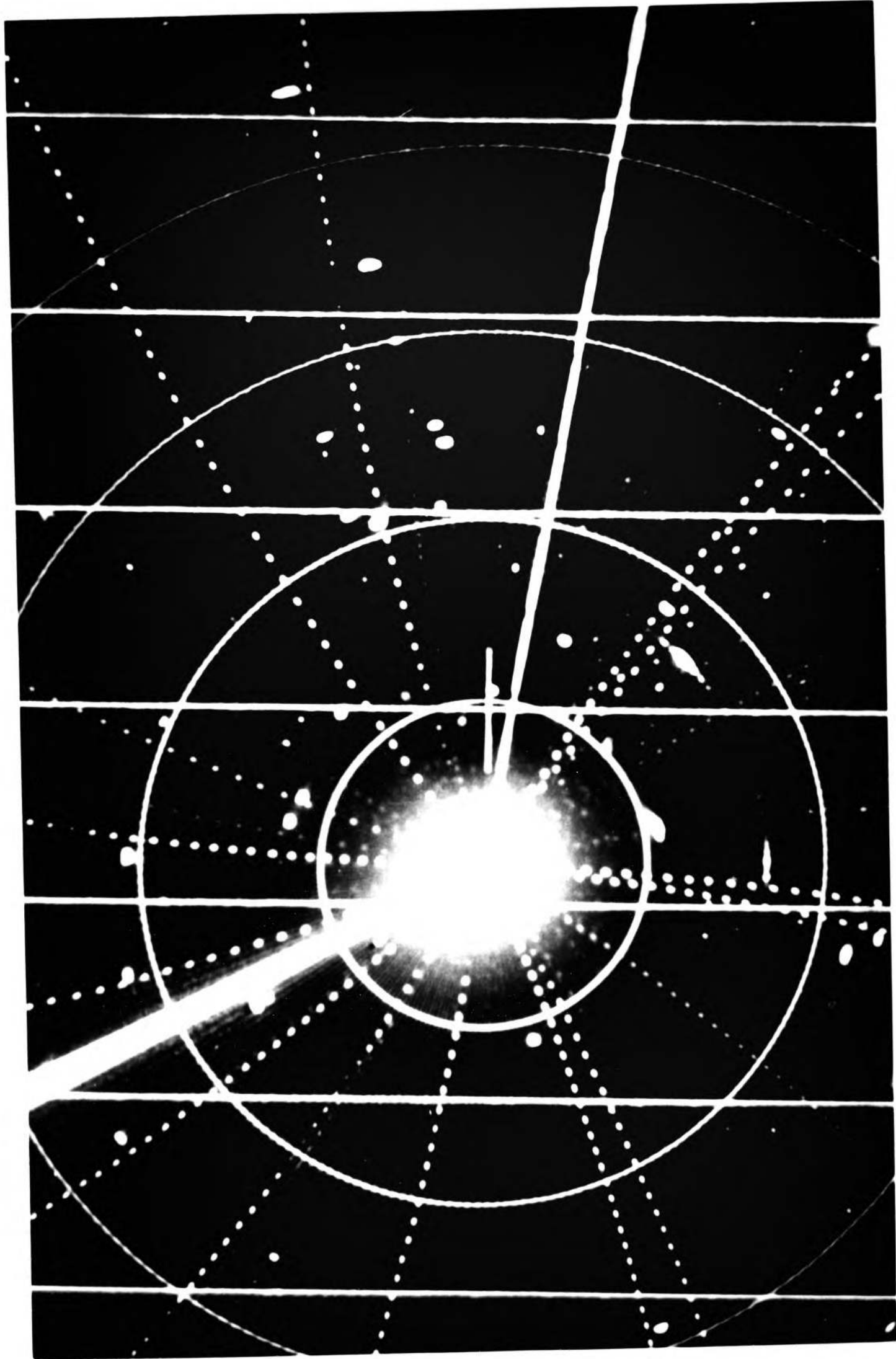

FIG. III.21 The Radar Picture at 0.42 on 21.5.72. Sunk Survey 1. (Light setting f5.6, exposure time 6 secs). This picture illustrates side-lobing effect.

to plot the exact position of the target and secondly another target may be concealed. However, as this effect is most likely at close ranges there will be information from the frames immediately adjacent to help resolve the two problems.

3. Sea Clutter

Sea-clutter takes the form of a large number of small echoes changing in position and brightness, all the time surrounding the centre of the screen. Since the fronts of waves give stronger echoes than the backs, the clutter area is usually oval extending more to windward as can be seen in Fig.III.22. This picture was taken during survey 2 when the sea was rather choppy, so to reduce the sea-clutter the anti-clutter control was used. Unfortunately in suppressing the clutter, echoes from boats and buoys will also have been suppressed. However, if this is not done, echoes will get lost in the clutter. This proved to be one of the most difficult problems in plotting as the positions of ships when passing through the clutter could not always be precisely determined. It was therefore, considered essential to keep the clutter low. A further example of the effect of sea clutter can be seen in Fig.III.23 which was taken on Survey 4, a survey which was not analysed for this thesis. A strong storm was blowing up which resulted in the ship having to take refuge in Harwich soon after this photograph was taken. It can be seen however that the centre of the screen has become very confused and echoes were very easily lost.

4. Multiple Echoes

When another ship is passing on an opposite or parallel course, it is possible for a second or even a third echo to appear beyond the true echo, on the same bearing and all at equal intervals of range. They are fairly easy to detect because of their equal spacing and eventual disappearance of the outer echoes. The effect is caused by the echo from the other ship being reflected back and forth between the hulls and still being strong enough to paint when it reflects for the third time.

5. False or Indirect Echoes

Some structures such as a funnel are very good reflectors of radio waves, and when they lie in the radar beam, a considerable portion of the energy will be reflected away. The direct echo will appear on its proper bearing and range but a false or indirect echo may also appear at the same range but on the bearing of the obstruction. Again the effect was fairly

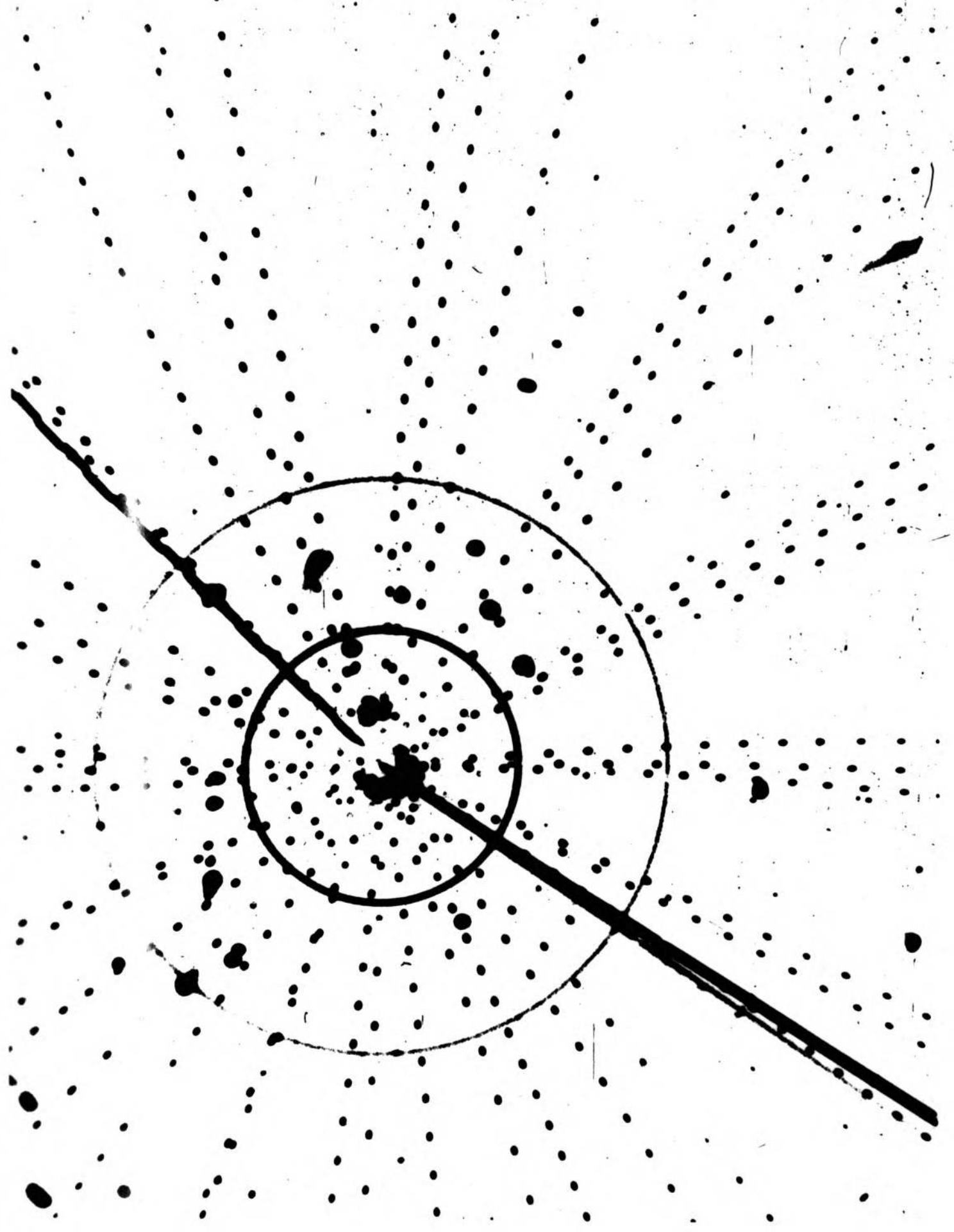

FIG. III.22 The radar picture at 17.45 on 2.7.72. Sunk Survey 2. (Light setting f5.6, exposure time 6 secs). This picture gives an example of the pictures shown by projection when preparing the tracks of ships through the survey area. The black area in the centre is sea clutter.

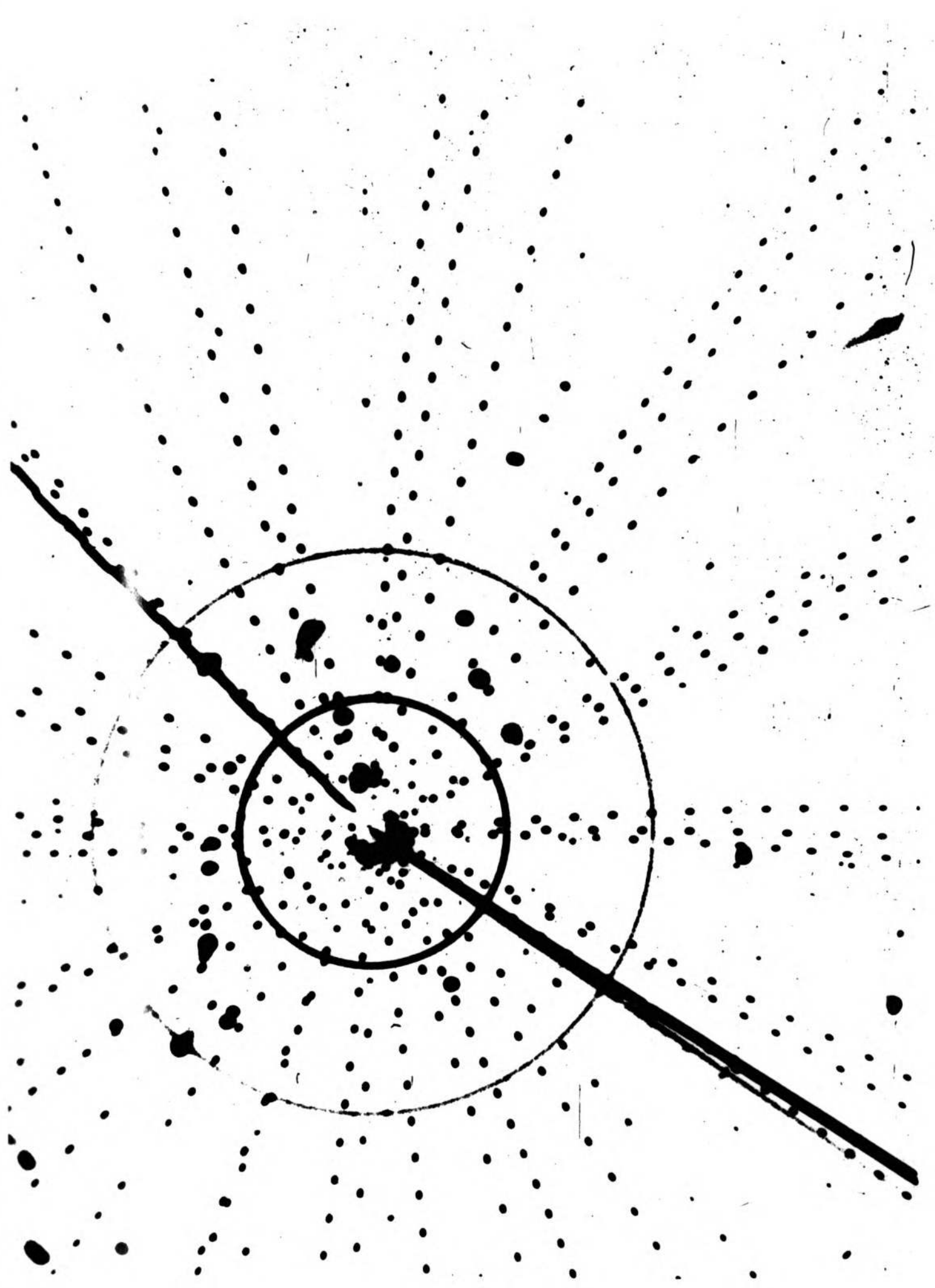

FIG. III.22 The radar picture at 17.45 on 2.7.72. Sunk Survey 2. (Light setting f5.6, exposure time 6 secs). This picture gives an example of the pictures shown by projection when preparing the tracks of ships through the survey area. The black area in the centre is sea clutter.

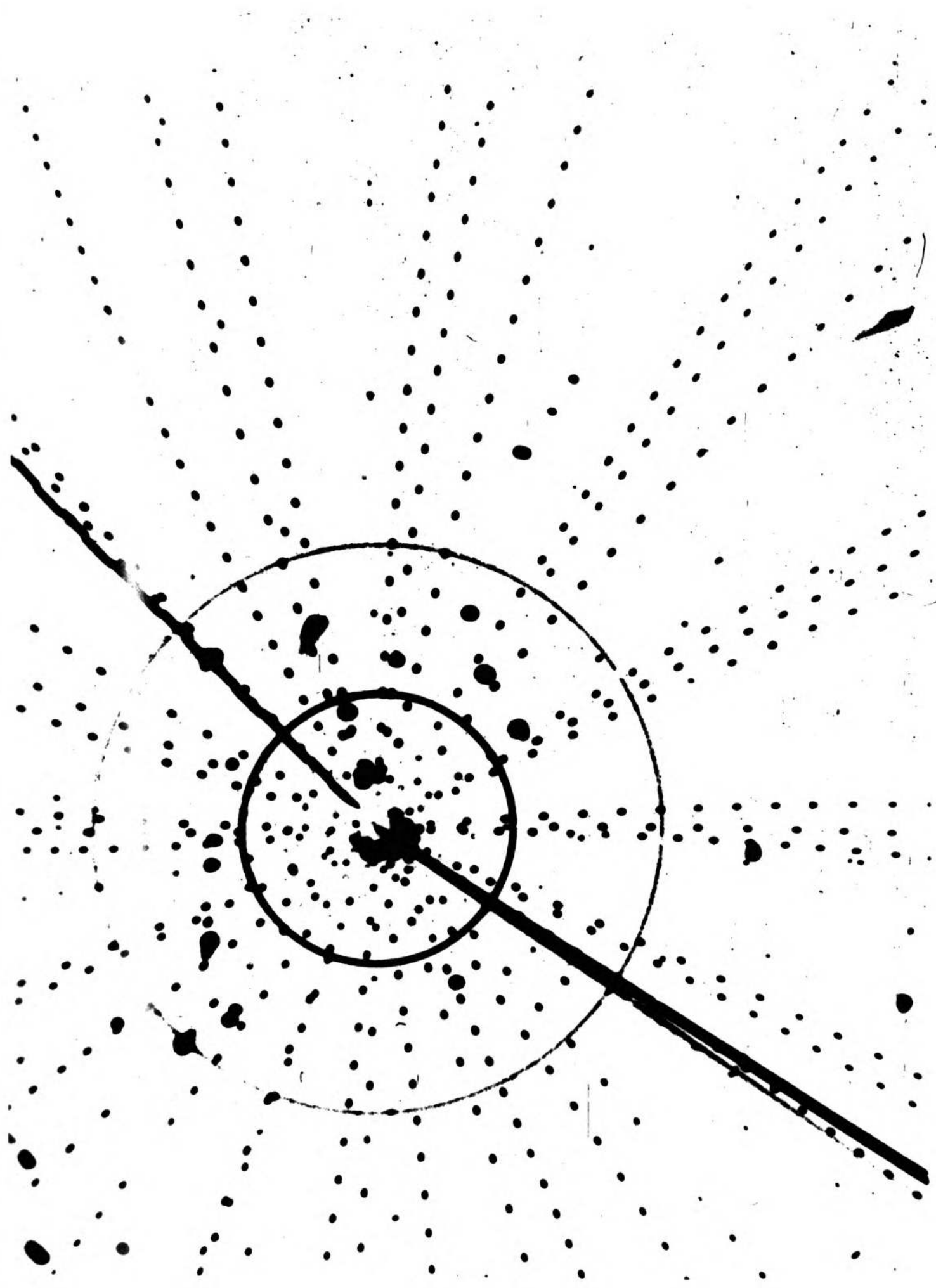

FIG. III.22 The radar picture at 17.45 on 2.7.72. Sunk Survey 2. (Light setting f5.6, exposure time 6 secs). This picture gives an example of the pictures shown by projection when preparing the tracks of ships through the survey area. The black area in the centre is sea clutter.

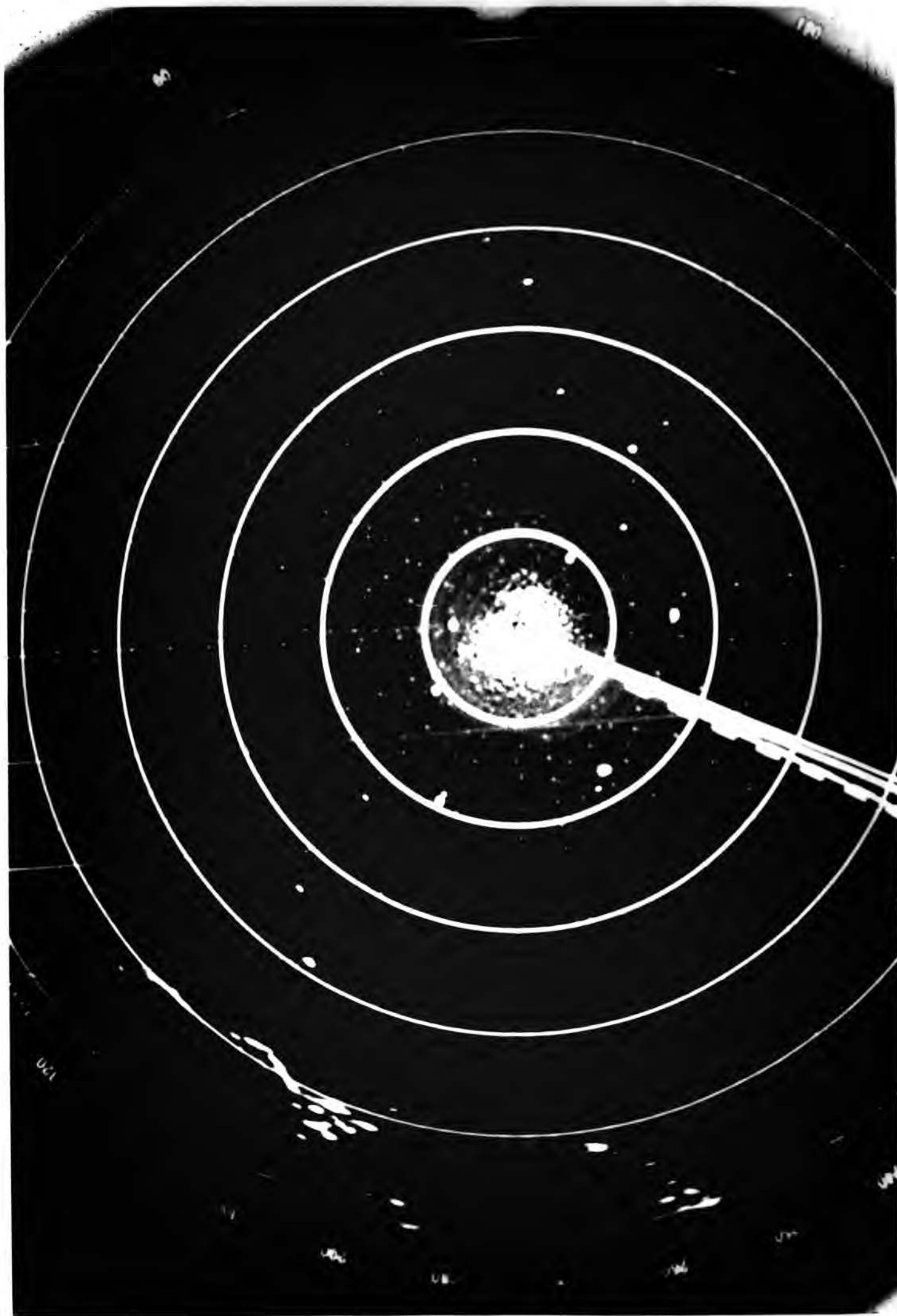

FIG. III.23 The radar picture at 21.54 on 31.3.73. Sunk Survey 4 (not analysed) (Light setting f5.6, exposure time 6 secs). This picture illustrates (a) the increase in coverage using a wide angle lens and (b) sea clutter.

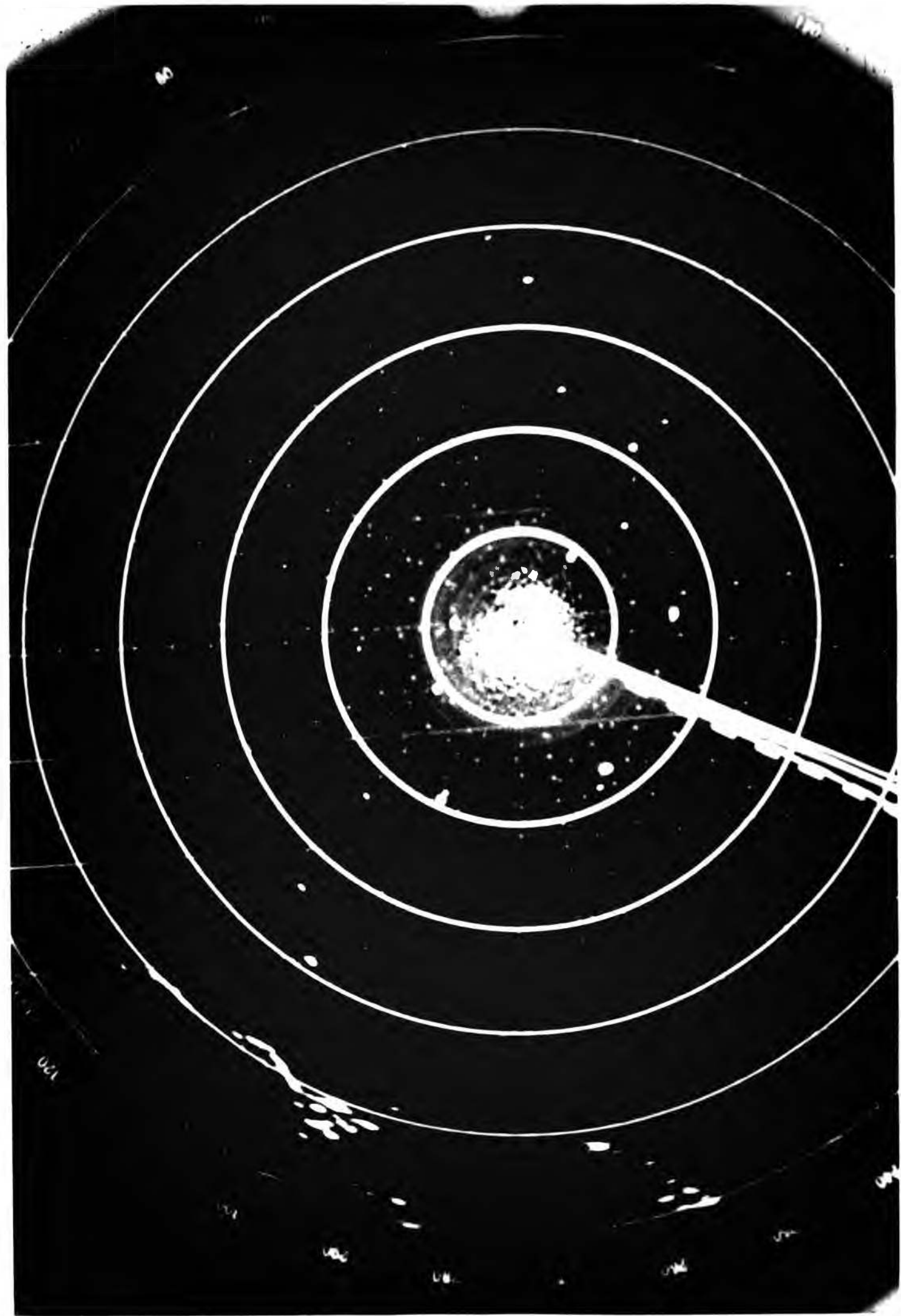

FIG. III.23 The radar picture at 21.54 on 31.3.73. Sunk Survey 4 (not analysed) (Light setting f5.6, exposure time 6 secs). This picture illustrates (a) the increase in coverage using a wide angle lens and (b) sea clutter.

easy to cope with because the false echo would disappear as suddenly as it had appeared. An occasional example of both of these two phenomena was encountered in the surveys.

APPENDIX III.VIII

REASONS FOR THE LOSS OF PHOTOGRAPHS IN THE THREE SUNK SURVEYS

| | Survey 1 | Survey 2 | Survey 3 |
|---|-------------|-------------|-------------|
| Number of six-minute time points recorded successfully | 72 | 225 | 132 |
| Number of six-minute time points lost | 9 | 14 | 9 |
| Total number of six-minute time points | 81 | 239 | 141 |
| Percentage loss | 11 | 6 | 6 |
| Time interval for photographs (mins) | 6 | 3 | 3 |
| Number of time points lost and reason | | | |
| Shutter malfunction | 8 | 3 | - |
| Film jamming | - | 12 | 7 |
| Changing film | 1 | 14 | 5 |
| Miscellaneous | - | 6 | - |
| Number of frames lost through the shutter malfunctioning but without loss of time | 5 | 18 | 14 |
| Number of frames exposed | 86 | 467 | 293 |
| Number of films needed | 2½ | 13½ | 9½ |

TABLE III.2 Comparison of the Success of the Photography in the Three Sunk Surveys

Table III.2 provides a comparison between the three Sunk surveys with respect to the success of the photography. The percentage of six minute time points actually lost in the course of each survey, given in the first part of the table may be compared to a non-response rate in a conventional sample survey. The reasons for failure to record at a given time interval are quoted in the second part and are evidently in no way related to the subject of the survey. The only non-random element in their occurrence was a tendency to happen when the operator was tired. It is thus suggested that this non-response should in no way bias the results of the surveys.

From a practical point of view there is obviously a need to gather as much useful material from a survey as possible so the reasons for the failures will be considered briefly. The vast improvement between Survey 1 and Surveys 2 and 3 has already been noted in the text and was due to a decision to record every three minutes rather than every six minutes. The number of films needed obviously went up but the cost of this was minimal compared to the cost and effort involved in starting a survey.

The table reflects the results of a gain in experience. Practice with changing the film meant that it could be changed within a three minute interval by the third survey. The figures recorded in the third survey for loss during this process were thus, five frames lost when light was allowed to get in, in a very tired moment. Experience also made it easier to detect a malfunction of the shutter usually caused by failure of the time release button to work properly. This in itself was due to two separate causes. At the start of the second survey, there appeared to be a fault in the camera so a replacement camera was used. Two cameras were always taken for such an event as this. The other reason was failure on the part of the operator to hold the button properly. It is noticeable that there was more non-mechanical errors in the third survey than in the other two, as this was the only one conducted single-handed.

The last part of the table gives information on the number of films necessary. Again, experience helped in that it was decided better to change a film whenever it showed signs of sticking in the hope of forestalling the time-consuming situations when the film broke. This happened on two separate occasions, one in Survey 2 and one in Survey 3. The film broke from its cassette, so in total darkness it had to be rewound by hand and kept in a sealed tin.

The main gain in Surveys 2 and 3 over Survey 1 is that a minor fault in Survey 1 meant the real loss of data but in Surveys 2 and 3 the loss of one three-minute frame due to a minor fault did not produce a real loss of data. Allowing for the fact that Survey 3 was conducted by a single person leading to an increase in human error, it is to be expected that future surveys should produce a non-response rate of even less than 6%.

APPENDIX III.IX

COMPARISON BETWEEN THE DISTRIBUTION OF SHIPS BY SIZE IDENTIFIED
IN THE SUNK SURVEYS AND WORLD WIDE

| Size of Ship Gross Registered Tonnage | Sunk Surveys | World Distribution |
|--|-----------------|-----------------------|
| 100 - 499 | 30 | 27079 |
| 500 - 999 | 6 | 6126 |
| 1000 - 1999 | 9 | 4328 |
| 2000 - 3999 | 13 | 5208 |
| 4000 - 5999 | 5 | 2259 |
| 6000 - 6999 | 5 | 1102 |
| 7000 - 7999 | 1 | 1404 |
| 8000 - 9999 | 4 | 2592 |
| 10000 and over | 15 | 7293 |
| Total | 88 | 57391 |

Notes (see p.322).

TABLE III.3 Number of Ships by Size (Gross Registered Tonnage) Fully Identified in the Sunk Surveys and Worldwide

Table III.3 gives the distributions by size of ships fully identified in the Sunk surveys and of ships worldwide from Lloyds Register of Shipping (1972). If the ships in the survey represented a random sample from the worldwide distribution of ships then the expected number of ships in each class would be as given below.

| SIZE OF SHIP gross registered tonnage | Observed Number in Sunk Surveys O_i | Expected Number E_i | $(O_i - E_i)^2/E_i$ |
|--|--|-----------------------------|---------------------|
| 100 - 499 | 30 | 41.52 | 3.196 |
| 500 - 999 | 6 | 9.39 | 1.224 |
| 1000 - 1999 | 9 | 6.64 | 0.838 |
| 2000 - 3999 | 13 | 7.99 | 3.141 |
| 4000 - 5999 | 5 | 3.46 | 0.685 |
| 6000 - 6999 | 5 | 1.69 | 6.483 |
| 7000 - 7999 | 1 | 2.15 | 0.615 |
| 8000 - 9999 | 4 | 3.98 | .000 |
| 10000 and over | 15 | 11.18 | 1.305 |
| Total | 88 | 88.00 | 17.487 |

Performing a χ^2 goodness of fit test the calculated value of χ^2 is 17.49,

where $\chi^2 = \sum \frac{(O_i - E_i)^2}{E_i}$ as defined above. With 8 degrees of freedom the

critical value of χ^2 at the 5% level of significance is 15.51. It would therefore seem reasonable to conclude that the observed distribution in the Sunk surveys does differ significantly from the worldwide distribution. The difference obviously lies in the relative over representation of the larger ships and a corresponding under representation of the smaller ships. This could be because more smaller ships were among those not identified since they did not need a pilot or because there are in fact relatively fewer small ships here than in the rest of the world. This latter finding would seem to be the most reasonable especially as it supports a similar conclusion reached by the author (1972)⁽³⁶⁾ using data from marine traffic surveys in the Dover Strait. In that area there was again an under representation of smaller ships.

APPENDIX IV. I

SIMULATOR DATA

COMMENTARY ON EXERCISE 19

Ship No. 3

Destination: Folkestone Pilot

Weather: Fog 1/4 mile visibility

True Course 045⁰

Initial Speed 10 knots

Gross Registered Tonnage 30,000

Full Speed 16 knots

Half Speed 11 knots

Slow speed 8 knots

Dead slow
speed 5 knots

| Time | Alterations |
|------|------------------------------------|
| 06 | altered course to 005 ⁰ |
| 09 | altered speed to Full ahead |
| 12 | altered course to 305 ⁰ |
| 19 | altered course to 359 ⁹ |
| 30 | altered speed to half ahead |
| 33 | altered speed to slow ahead |

APPENDIX IV.II

FORMAT OF THE COMPUTER RECORDS: SIMULATOR DATA

For each exercise there were four types of cards. The first contained the necessary parameters for the exercise, the second the details on the speeds and courses of all the ships, the third information on the experience of the navigators, the size of the ships and their maximum speed and the fourth the distance and relative bearings of the other ships taking each own ship as central ship in turn.

Exercise Parameters

It was necessary to define six parameters on the identification card for each exercise. They were

1. course number,
2. exercise number
3. number of time points recorded
4. number of own ships
5. number of target ships,
6. number of ship encounters to be considered.

The course number was purely for identification, as the original tracings, notes and other information were available by course. The exercise number also helped in identification and was necessary when the analyses by type of sea area were carried out. The number of time points was the number of points separated by six minute intervals at which the relative positions of all the ships were recorded. This had to be defined separately for each exercise as the length of recording time was obviously a variable. The number of target ships was also a variable, and sometimes two exercises of the same number would be changed by bringing in a stationary target or even an extra target, once one had passed out of range. Thus this could not be linked to the exercise number. It was also necessary to specify the number of own ships since there were one or two occasions where all three could not be separately distinguished. The final parameter, number of ship encounters to be considered could have been calculated in the program but as it was a useful figure to have when preparing the records, it was included on the parameter card. For the early exercises where the 'own' ships did not see each other, this figure was simply the number of own ships x the number of targets. However, in the later exercises it was equal to the

APPENDIX IV.II

FORMAT OF THE COMPUTER RECORDS: SIMULATOR DATA

For each exercise there were four types of cards. The first contained the necessary parameters for the exercise, the second the details on the speeds and courses of all the ships, the third information on the experience of the navigators, the size of the ships and their maximum speed and the fourth the distance and relative bearings of the other ships taking each own ship as central ship in turn.

Exercise Parameters

It was necessary to define six parameters on the identification card for each exercise. They were

1. course number,
2. exercise number
3. number of time points recorded
4. number of own ships
5. number of target ships,
6. number of ship encounters to be considered.

The course number was purely for identification, as the original tracings, notes and other information were available by course. The exercise number also helped in identification and was necessary when the analyses by type of sea area were carried out. The number of time points was the number of points separated by six minute intervals at which the relative positions of all the ships were recorded. This had to be defined separately for each exercise as the length of recording time was obviously a variable. The number of target ships was also a variable, and sometimes two exercises of the same number would be changed by bringing in a stationary target or even an extra target, once one had passed out of range. Thus this could not be linked to the exercise number. It was also necessary to specify the number of own ships since there were one or two occasions where all three could not be separately distinguished. The final parameter, number of ship encounters to be considered could have been calculated in the program but as it was a useful figure to have when preparing the records, it was included on the parameter card. For the early exercises where the 'own' ships did not see each other, this figure was simply the number of own ships x the number of targets. However, in the later exercises it was equal to the

number of ways the three own ships could be considered in pairs which is $6(3!) +$ the number of own ships x the number of targets. The target ships are not considered as central ships for the reasons discussed on p.36 in the text.

Speeds and Courses

The second type of cards contained information on the speeds and courses of each of the own ships and target ships. For own ship one its speed and course at time point one, the start of the exercise was given and then followed by its speed and course at the subsequent time points recorded. This was followed with the same information for own ship two, own ship three and then the target ships. The speed was given correct to the nearest integer as it was felt that no greater accuracy was justified. Similarly the courses were given to the nearest degree measured from the north line which was given on all the tracings.

Experience, Size and Maximum Speed

The third card set contained the information on the experience of the navigating officer, the size of his ship in gross registered tons and its maximum speed for own ship one, followed by that for own ships two and three. These were obtained as described in the previous chapter. Whenever the information was not available, special codes were used which are listed later in this Appendix, p.248.

Distance and Relative Bearing

No identification number was given to the individual pieces of data within the second and third sets. It was later felt that this would have been a good idea in case the cards got out of order. As the second type of information on speeds and courses was punched on several cards, when this happened it proved rather lengthy to sort out. An identification number was given with each of the distance and relative bearing readings so that they could be easily identified in checks and in the analyses. A typical number was 400190323 which could be read as 400 - course number, 19 - exercise number, 03 - time point of 12 minutes from the start, 23 - the relative position of own ship 3 with respect to own ship 2. After each number the appropriate distance and relative bearing was given, the distance being correct to the nearest tenth of a mile and the bearing to the nearest degree. This again was the highest degree of accuracy considered justifiable. When the own ships are considered with respect

to each other, it is evident that the number 400190332 would refer to the same distance as in the case above but the relative bearing would be different. For this reason, both were read in separately. In a similar manner to the second set of data the distances and relative bearings between two ships for each time point were read in consecutively, and the sequence was repeated for the other pairs of ships. If two ships could not see each other on the radar screen because of distance or land obstruction, figures of 99 for the distance and 999 for the bearing were entered so that they would not come into the analysis but the ordering of entries for the program would not be disturbed. A similar convention was used for the speed and course of a ship that was not present at a given point in time on the display but was involved at some stage in the exercise. The precise ordering of the encounters and a summary of the card pack for each exercise are given on the next page, followed by a print out from the exercise shown in Fig. 4.3 in the text.

SUMMARY OF THE FORMAT OF THE RECORDS FOR EACH EXERCISE: SIMULATOR DATA

1. Exercise Parameters

Course number, Exercise number, Number of time points recorded, Number of own ships, Number of target ships, Number of encounters to be considered.

2. Speeds and courses for all time points

Own ship 1
Own ship 2
Own ship 3
Target 1 etc.

3. Experience, size and maximum speed

Own ship 1
Own ship 2
Own ship 3

4. Distances and relative bearings for all time points

| Exercises 1 - 6 | (Code) | Exercises 7 - 20 | (Code) |
|-----------------------|--------|-------------------------|--------|
| Own ship 1 v Target 1 | (14) | Own ship 1 v Own ship 2 | (12) |
| v Target 2 etc | (15) | Own ship 2 v Own ship 1 | (21) |
| Own ship 2 v Target 1 | (24) | Own ship 1 v Own ship 3 | (13) |
| v Target 2 etc | (25) | Own ship 3 v Own ship 1 | (31) |
| Own ship 3 v Target 1 | (34) | Own ship 2 v Own ship 3 | (23) |
| v Target 2 etc | (35) | Own ship 3 v Own ship 2 | (32) |
| | | Own ship 1 v Target 1 | (14) |
| | | v Target 2 etc | (15) |
| | | Own ship 2 v Target 1 | (24) |
| | | v Target 2 etc | (25) |
| | | Own ship 3 v Target 1 | (34) |
| | | v Target 2 etc | (35) |

Records of Exercise No. 19.

400 19 9 3 4 18
10.5 186. 10.5 186. 10.5 123. 10.5 123. 10.5 202. 10.5 202. 10.5 202. 10.5 202.
10.5 252
0.0 072. 0.0 072. 0.0 072. 0.0 072. 0.0 072. 0.0 072. 6.0 020. 0.0 340. 12.0 318.
15.0 028.
10.0 068. 10.0 014. 16.0 305. 16.0 305. 16.0 359. 11.0 359. 8.0 359. 8.0 359.
8.0 359.
6.0 271. 6.0 271. 6.0 271. 6.0 255. 10.0 255. 8.0 255. 8.0 227. 8.0 227.
8.0 227.
10.0 243. 10.0 243. 10.0 243. 10.0 226. 10.0 226. 10.0 252. 10.0 252. 10.0 236.
10.0 236.
6.0 066. 5.0 045. 4.0 045. 2.0 045. 0.0 045. 0.0 045. 6.0 045. 6.0 061.
6.0 028.
8.0 242. 8.0 242. 8.0 242. 8.0 242. 8.0 242. 8.0 242. 8.0 242. 8.0 242.
8.0 242.
19 20000 15 6 999 20 16 30000 16
400190112 9.6 026. 400190212 8.3 030. 400190312 7.5 096. 400190412 7.5 101.
400190512 7.6 026. 400190612 6.1 028. 400190712 4.7 036. 400190812 4.5 059.

400190912 4.5 026. 400190121 9.3 320. 400190221 8.3 324. 400190321 7.5 327.
400190421 7.5 332. 400190521 7.6 336. 400190621 6.1 030. 400190721 4.7 078.
400190821 4.5 123. 400190921 4.5 070. 400190113 8.6 018. 400190213 6.4 014.
400190313 4.6 082. 400190413 4.6 097. 400190513 4.2 038. 400190613 3.2 063.
400190713 3.1 095. 400190813 3.8 114. 400190913 4.3 075. 400190131 8.6 316.
400190231 6.4 006. 400190331 4.6 080. 400190431 4.6 095. 400190531 4.2 061.
400190631 3.2 086. 400190731 3.1 118. 400190831 3.8 137. 400190931 4.3 148.
400190123 1.4 016. 400190223 2.7 001. 400190323 3.2 348. 400190423 3.0 336.
400190523 3.7 323. 400190623 3.9 001. 400190723 4.1 037. 400190823 3.9 070.
400190923 3.7 006. 400190132 1.4 200. 400190232 2.7 239. 400190332 3.2 295.
400190432 3.0 283. 400190532 3.7 214. 400190632 3.9 202. 400190732 4.1 198.
400190832 3.9 209. 400190932 3.7 217. 400190114 7.0 021. 400190214 6.3 030.
400190314 5.9 102. 400190414 6.4 110. 400190514 7.2 037. 400190614 7.2 044.
400190714 7.2 050. 400190814 7.8 053. 400190914 7.9 001. 400190115 4.7 006.
400190215 4.3 018. 400190315 4.3 092. 400190415 5.1 102. 400190515 5.6 030.
400190615 5.3 035. 400190715 5.2 042. 400190815 5.7 050. 400190915 5.9 357.
400190116 7.9 018. 400190216 6.1 018. 400190316 4.8 082. 400190416 4.3 088.
400190516 3.7 017. 400190616 2.6 021. 400190716 1.7 031. 400190816 0.6 074.
400190916 0.8 123. 400190117 3.1 312. 400190217 2.2 311. 400190317 1.5 015.
400190417 1.1 073. 400190517 1.8 018. 400190617 1.7 052. 400190717 2.0 065.

400190817 2.5 072. 400190917 2.9 022. 400190124 2.3 335. 400190224 2.0 326.
400190324 1.7 310. 400190424 1.6 295. 400190524 1.5 271. 400190624 2.2 276.
400190724 3.0 293. 400190824 3.5 284. 400190924 4.4 199. 400190125 5.2 339.
400190225 4.2 336. 400190325 3.2 331. 400190425 2.5 326. 400190525 2.0 326.
400190625 1.0 350. 400190725 0.8 302. 400190825 1.7 256. 400190925 3.0 174.
400190126 1.7 357. 400190226 2.7 352. 400190326 3.1 351. 400190426 3.6 347.
400190526 4.1 345. 400190626 3.6 035. 400190726 3.0 081. 400190826 3.9 120.
400190926 4.6 060. 400190127 8.8 340. 400190227 8.1 339. 400190327 7.3 338.
400190427 6.6 336. 400190527 5.8 335. 400190627 4.6 021. 400190727 3.1 059.
400190827 2.1 107. 400190927 1.6 076. 400190134 1.6 301. 400190234 1.6 288.
400190334 2.2 324. 400190434 2.2 313. 400190534 3.0 240. 400190634 4.3 233.
400190734 5.8 230. 400190834 7.0 226. 400190934 8.0 223. 400190135 4.1 330.
400190235 2.1 001. 400190335 1.0 019. 400190435 0.7 323. 400190535 1.6 213.
400190635 2.9 206. 400190735 4.3 209. 400190835 5.6 212. 400190935 6.6 211.
400190936 0.6 304. 400190236 0.4 309. 400190336 0.2 235. 400190436 0.8 158.
400190536 1.5 119. 400190636 2.1 136. 400190736 2.9 149. 400190836 3.3 142.
400190936 3.8 139. 400190137 7.8 337. 400190237 5.8 031. 400190337 4.2 098.
400190437 3.6 103. 400190537 2.3 068. 400190637 1.6 098. 400190737 1.7 153.
400190837 2.5 180. 400190937 3.4 193.

APPENDIX IV.III

SPECIAL DATA CODES: SIMULATOR DATA

| <u>Code</u> | <u>Situation when used</u> |
|-------------------------------------|---|
| Speed 99 Course 999 | the ship was not on the screen |
| Distance 99 Relative Bearing 999 | one of the two ships was not on the screen, or there was a land obstruction hindering the view. |
| Experience 0 | The student was now in a shore job so length of sea-experience could not easily be calculated. |
| Experience 99 | No information available. |
| Gross registered tonnage 0 | No information available. |
| Maximum speed 0 | No information available |

APPENDIX IV. IV

CHECKING PROCEDURES FOR THE PROGRAMS AND DATA. SIMULATOR DATA

Some independent checking procedures were devised both for the programs and for the data.

The basic program was developed using a set of test data designed especially to check that values near the division points of the cells were correctly assigned. Once developed, the program was run using a sample of the data which had also been analysed by hand and the two results were compared. A similar procedure was used to check any modifications made to the basic program such as the calculation of relative velocities and subsequent production of the distributions by various independent variables.

The data was read in partly in real format and partly in integer format which provided a check that there was sufficient data per exercise. Abnormally high or low values of the variables were checked by getting printouts whenever they occurred.

In the later exercises when the echoes of all the own ships appeared on the screens, the successive distances in the encounter between ship 1 as central ship and ship 2 should be the same as in the encounter between ship 2 as central ship and ship 1, and similarly for the other pairs of own ships. This could be used therefore as a check in this situation.

A final check which could be used was to consider the pattern of separation distances in an encounter. For a simple exercise the curve of distance against time was roughly U-shaped and even for the more complicated exercises there should be no large sudden variations from this basic pattern even if only part of the U shape were present.

respectively. It could also be changed if a ship was at anchor. The full list of position codes was as follows:

Positions

| <u>Data Code</u> | <u>Position in the Area</u> |
|------------------|---|
| 0 | Open sea |
| 8 | Channel |
| | Within 1 mile radius of pilot vessel |
| 9 | and passing through |
| 10 | Inward { approaching without a pilot leaving with a pilot |
| 11 | |
| 12 | Outward { approaching with a pilot leaving without a pilot |
| 13 | |
| 6 | Leaving from anchor |
| 7 | Coming to anchor |

The length between perpendiculars in feet and the gross registered tonnage were as found in Lloyds' Register of Shipping whenever a ship had been identified. If they were completely unknown, then a 0 was entered in each case, but if the type alone could be identified, a special code number was entered for both variables. This applied to fishing boats, ferries, yachts, the pilot boat and the relief pilot boat when this appeared from Harwich. The full list of size codes used was as follows:-

Size

| <u>Length/gross registered tonnage</u> | <u>Type of Ship</u> |
|--|---|
| <u>Data Codes</u> | |
| 0 / 0 | Not known |
| 6 / 6 | Yacht |
| 7 / 7 | Ferry if exact details not known |
| 8 / 8 | Fishing vessel |
| 9 / 9 | Pilot vessel |
| 99 / 99 | Relief pilot vessel on journey to and from its station |

Length between perpendiculars
in feet and gross registered
tonnage as in Lloyds Register
of Shipping

All ships fully identified

APPENDIX IV.VI

CHECKING PROCEDURES: SUNK SURVEY DATA

Since the programs for this data were more complex they were checked very thoroughly to ensure they were doing the correct tasks using both test data and then by running a sample of real data and cross-checking the results with those obtained manually.

The data itself was checked using a program designed to spot any anomalies. Thus it checked that every record bearing the same ship number also had the same tonnage and length. Again for any particular ship, the records for time, point T and T + 1 should correspond so that the second set of coordinates given for the record at time T should be very similar to the first set of coordinates given for the record of time T + 1. It was arranged that if they were not equal a printout was given which could be checked against the original plots.

It was also arranged that, since the cards were grouped by hour, the number of cards in an hour was given in integer format and the ship numbers were given in real format which made it easy to locate incomplete records or ones wrongly placed once the data had been checked. The main checking program also checked that all the cards within an hour group did in fact belong to that hour.

APPENDIX IV.VII

A STATISTICAL INVESTIGATION INTO THE
DISTRIBUTION OF NUMBER OF SHIPS PER SECTOR (SIMULATOR DATA)

1. ALL EXERCISES COMBINED

In the discussion on p.79 it was suggested that there are some peculiarities in the distributions of number of ships per sector, which make the distributions other than what might have been expected by chance alone. It is proposed to examine this question statistically in this section.

In theory since the areas of the sectors are in the ratio 5:5:6, with Sector 3 the largest, then the observed numbers of ships per sector should be in this ratio as well. Consideration of the results for all exercises combined reveals the following picture:

| | Sector 1 | Sector 2 | Sector 3 | Total |
|--------------------------|----------|----------|----------|-------|
| Observed number of ships | 1174 | 1181 | 769 | 3124 |
| Expected number of ships | 976.25 | 976.25 | 1171.5 | 3124 |

X Performing a χ^2 goodness of fit test a value of $\chi^2 = 221.29$ is calculated which is significant at the .1% level, using χ^2 on 2 degrees of freedom. ($\chi^2_{.1\%} = 13.81$). The difference obviously lies in the under-representation of Sector 3.

Another reason for this discrepancy other than the one given in the discussion, of the tendency to finish all exercises as soon as the collision situation is successfully resolved, might be that the presence of the domain causes the distribution to be other than the theoretical random one. However, there is no reason to suggest why in general the domain should affect the number of points in total falling into each sector, provided a reasonably sized area around the ship such as a circle of 5 mile radius is considered, even though it affects the distribution of points within each sector. To help resolve this, a similar analysis of the total number of points per sector for the Sunk surveys might be useful.

For all surveys combined the observed and expected frequencies, under the same hypothesis as before, are as follows:

| | Sector 1 | Sector 2 | Sector 3 | Total |
|--------------------------|----------|----------|----------|-------|
| Observed number of ships | 1401 | 1301 | 1979 | 4681 |
| Expected number of ships | 1462.81 | 1462.81 | 1755.38 | 4681 |

This gives a χ^2 value of 49.00 which is again significant at the .1% level. The difference here could lie between Sector 1 and Sector 2 or mainly because Sector 3 is so much larger than the other two.

Considering Sectors 1 and 2 alone and using a null hypothesis that they should be equal, the following results are obtained:-

| | Sector 1 | Sector 2 | Total |
|--------------------------|----------|----------|-------|
| Observed number of ships | 1401 | 1301 | 2702 |
| Expected number of ships | 1351 | 1351 | 2702 |

χ^2 is calculated as 3.70. As the 5% value of the χ^2 distribution with one degree of freedom is 3.84 this is a non-significant result and it is probably reasonable to conclude that there is no real difference between Sectors 1 and 2. Thus in fact the Sunk surveys show a larger than expected number of values in the third sector. The problem of whether this result is truly a result of the domain or a result of the particular area of the survey, is something that must be investigated more fully at a later stage. However, at this stage of the argument it seems to lend support to the statement that the simulator data is very much under represented in the third sector.

2. SINGLE EXERCISES

It was also suggested in the discussion on p.79 that the different exercises on their own lead to differences in the representations of each of the sectors.

Considering for example, exercise 1, the initial situation for which is given in Fig.III.I, the number of points observed in each sector were as follows:

Sector 1 : 39
Sector 2 : 18
Sector 3 : 11

Again under the same hypothesis as previously the numbers expected in each sector were:-

Sector 1 21.25
Sector 2 21.25
Sector 3 25.50

This gives a χ^2 value of 23.56 when a goodness of fit test is performed, which is significant at the .1% level. Although there is a discrepancy in Sector 3 compared to the other two, there is also a significant difference between Sectors 1 and 2 (χ^2 calculated = 7.74 significant at the 1% level).

In this case it arises because the majority of ships will have manoeuvred so that by the time the separation distance between the 'own' ship and the target ship is less than 5 miles the target ship will be in Sector 1 of the 'own' ship. Hence one exercise on its own can obviously not be used for all sectors.

3. TYPES OF EXERCISES

Considering the simulator data broken down into the three main types of exercise viz:- Open Ocean, Gibraltar and Dover Strait, the following observed distribution of numbers of ships arise:-

| | Sector 1 | Sector 2 | Sector 2 | Total |
|------------------|----------|----------|----------|-------|
| Open Ocean | 361 | 394 | 165 | 920 |
| Gibraltar Strait | 450 | 583 | 371 | 1404 |
| Dover Strait | 363 | 204 | 233 | 800 |

Since Sector 3 must be ignored, then under the hypothesis that the numbers in Sector 1 and Sector 2 are equal, the following values of χ^2 are obtained:-

| | χ^2 |
|------------------|----------|
| Open Ocean | 1.44 |
| Gibraltar Strait | 17.12 |
| Dover Strait | 44.59 |

Since the values of χ^2 on 1 d.o.f. are 3.84 for 5% and 10.83 for .1%, the Open Ocean result is non-significant but the other two are very highly significant. As however the Gibraltar and Dover results differ so that in one case sector 1 is more represented and in the other sector 2 has the largest number of points, the effect is not systematic. The cause may be due to the type of exercise within each area but more interestingly may be due to the type of navigation necessary within a particular area. This idea is supported by the results for the Sunk Survey just analysed where there was an abnormally high incidence of points in Sector 3 and the results for the Open Ocean. Further support is given in table IV.1 which shows for the individual exercises within each of the two types of situation, the distributions by sector.

| EXERCISE SITUATION | STRAIT OF GIBRALTAR | | | | | DOVER STRAIT | | |
|--------------------|---------------------|-----|-----|-----|-----|--------------|-----|-----|
| | Exercise No. | 9 | 10 | 11 | 12 | 13 | 18 | 19 |
| SECTOR 1 | 107 | 98 | 61 | 141 | 43 | 32 | 85 | 246 |
| SECTOR 2 | 138 | 189 | 36 | 131 | 89 | 27 | 54 | 123 |
| SECTOR 3 | 78 | 104 | 30 | 87 | 72 | 42 | 41 | 150 |
| TOTAL | 323 | 391 | 127 | 359 | 204 | 101 | 180 | 519 |

TABLE IV.1 The Distribution of Total Number of Ships by Sector and by Exercise: Simulator Data - Dover Strait and Strait of Gibraltar

CONCLUSIONS

1. There is statistical evidence to suggest an under representation of Sector 3 in the simulator data.
2. It is recommended that the early open ocean exercises should not be analysed separately for each sector.
3. There appears to be a difference between the distributions by sector for different areas. With the added information from the Sunk surveys this would suggest the difference arises in the different areas and not necessarily from the exercise situations. Whichever is the cause there should be sufficient data for each of the sectors to be analysed in each situation. This point will be taken up again in more detail in Chapter 6, the discussion on the effects of the different variables.

APPENDIX IV.VIII

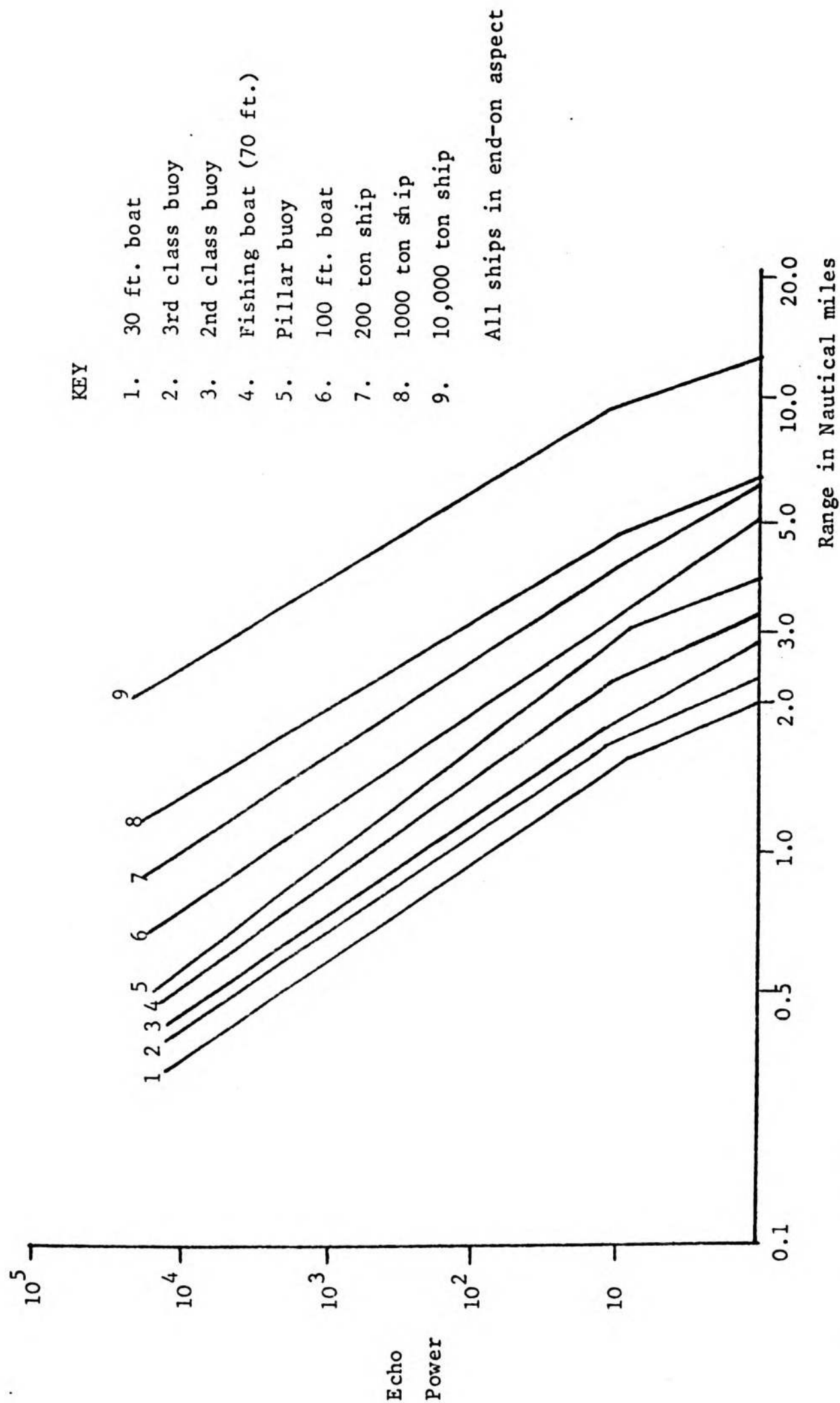

Notes (see p.322)

FIG.IV.VIII Typical Echo Strength Curves for Various Targets

APPENDIX IV.IX

COMPARISON OF THE DISTRIBUTIONS OBTAINED
FROM THE THREE SEPARATE SUNK SURVEYS

Using the modified basic distributions as defined on p.76 , the number of points falling within bands of width 1 mile for each of the three surveys were as shown below. The three sectors have been combined for this purpose.

| Distance from the Centre | Survey No. | | | Total |
|---------------------------------------|------------|------|------|-------|
| | 1 | 2 | 3 | |
| Within 1 mile | 82 | 86 | 101 | 269 |
| 1 mile or more but less than 2 miles | 274 | 345 | 316 | 935 |
| 2 miles or more but less than 3 miles | 382 | 512 | 411 | 1305 |
| 3 miles or more but less than 4 miles | 409 | 421 | 361 | 1191 |
| 4 miles or more but less than 5 miles | 353 | 328 | 300 | 981 |
| Total No. of points | 1500 | 1692 | 1489 | 4681 |

Treating the above data as a contingency table with a null hypothesis that the distance a point chosen at random is from the centre is independent of which survey, it belongs to the following table of expected frequencies is found. The figure in brackets in each cell is the contribution to the sum $\sum \frac{(O_i - E_i)^2}{E_i}$ arising from that cell where O_i is the observed frequency and E_i is the expected frequency.

| Distance from the Centre | Survey 1 | Survey 2 | Survey 3 |
|---------------------------------------|--------------|--------------|--------------|
| Within 1 mile | 86.2(.205) | 97.2(1.297) | 85.6(2.782) |
| 1 mile or more but less than 2 miles | 299.6(2.191) | 338.0(.146) | 297.4(1.161) |
| 2 miles or more but less than 3 miles | 418.2(3.130) | 471.7(3.458) | 415.1(.041) |
| 3 miles or more but less than 4 miles | 381.6(1.982) | 430.5(.210) | 378.9(.841) |
| 4 miles or more but less than 5 miles | 314.4(4.749) | 354.6(1.994) | 312.1(.465) |

The total sum $\sum \frac{(O_i - E_i)^2}{E_i}$ is 24.65

Since this is a 5 x 3 table, there are 8 degrees of freedom and the 5% χ^2 value is 15.51. This suggests that there is a significant difference between the surveys. On inspection, the major differences

would seem to arise between Survey 3 and the other two. In Survey 3 there are relatively more closer points than in the other two, but the other surveys have larger numbers of more distant points. This could well be partly explained since the position for Survey 3 was rather more northerly than in the other two surveys.

| | EXERCISE NUMBER | | | | | | | | | | | | | | | | | | | | TOTAL |
|------------------|-----------------|------|------|------|------|------|------|------|------|------|------|------|------|------|------|------|------|------|------|------|-------|
| | 1 | 2 | 3 | 5 | 6 | 7 | 8 | 9 | 10 | 11 | 12 | 13 | 16 | 18 | 19 | 20 | | | | | |
| Total | 39 | 31 | 59 | 41 | 122 | 16 | 14 | 107 | 98 | 61 | 141 | 43 | 39 | 32 | 85 | 246 | 361 | 450 | 363 | 1174 | |
| Fifth Percentile | 1.70 | 2.35 | 1.30 | 1.71 | 2.40 | 2.94 | 1.67 | 1.04 | 1.29 | 1.01 | 1.20 | 1.22 | 1.50 | 0.76 | 1.06 | 1.01 | 1.78 | 1.14 | 0.94 | 1.15 | |
| Total | 19 | 22 | 79 | 39 | 97 | 57 | 58 | 138 | 189 | 36 | 131 | 89 | 23 | 27 | 54 | 123 | 394 | 583 | 204 | 1181 | |
| Fifth Percentile | 1.60 | 2.01 | 1.60 | 1.30 | 1.59 | 2.54 | 2.09 | 0.90 | 1.17 | 1.19 | 0.76 | 1.35 | 1.31 | 0.77 | 0.77 | 0.76 | 1.64 | 1.03 | 0.76 | 1.06 | |
| Total | 11 | 7 | 23 | 30 | 38 | 9 | 21 | 78 | 104 | 30 | 87 | 72 | 26 | 42 | 41 | 150 | 165 | 371 | 233 | 769 | |
| Fifth Percentile | 1.26 | 3.84 | 1.12 | 1.45 | 0.59 | 2.65 | 3.31 | 0.79 | 0.92 | 1.55 | 0.75 | 1.26 | 0.87 | 1.41 | 0.75 | 0.53 | 1.16 | 0.91 | 0.63 | 0.84 | |
| Sample Size | 18 | 17 | 24 | 16 | 21 | 15 | 9 | 12 | 15 | 6 | 12 | 12 | 6 | 3 | 6 | 15 | 126 | 57 | 24 | 207 | |

N. Miles

All open ocean (1,2,3,5,6,7,8,16)
All Gibraltar (9,10,11,12,13)
All Dover Strait (18,19,20)

Notes (see p.322)

TABLE V.1 The Fifth Percentiles of the Distributions of Separation Distance (5.0 Nautical Miles or Less) by Sector and by Exercise Simulator Data

| | EXERCISE NUMBER | | | | | | | | | | N. Miles | | | | TOTAL | | | | | |
|---------------------------|-----------------|------|------|------|------|------|------|------|------|------|----------|------|------|------|-------|------|------|------|------|------|
| | 1 | 2 | 3 | 5 | 6 | 7 | 8 | 9 | 10 | 11 | 12 | 13 | 16 | 18 | | 19 | 20 | | | |
| SECTOR 1 Total | 11 | 3 | 12 | 12 | 10 | - | 4 | 38 | 35 | 21 | 61 | 16 | 8 | 21 | 27 | 94 | 60 | 171 | 142 | 373 |
| SECTOR 1 Lowest Decile | 1.61 | 2.31 | 1.02 | 1.52 | 1.80 | - | 1.64 | 0.98 | 1.15 | 0.91 | 1.11 | 0.86 | 1.28 | 0.81 | 0.97 | 0.87 | 1.45 | 1.00 | 0.86 | 0.97 |
| SECTOR 2 Total | 5 | 2 | 17 | 9 | 21 | 2 | 3 | 65 | 79 | 13 | 50 | 30 | 9 | 13 | 28 | 63 | 68 | 237 | 104 | 409 |
| SECTOR 2 Lowest Decile | 1.55 | 1.92 | 1.24 | 1.19 | 1.41 | 2.41 | 2.03 | 0.88 | 1.06 | 1.17 | 0.68 | 1.20 | 1.79 | 0.77 | 0.77 | 0.77 | 1.34 | 0.94 | 0.77 | 0.93 |
| SECTOR 3 Total | 4 | - | 7 | 4 | 9 | - | - | 31 | 34 | 13 | 34 | 21 | 4 | 20 | 12 | 82 | 28 | 133 | 114 | 275 |
| SECTOR 3 Lowest Decile | 1.24 | - | 1.07 | 0.94 | 0.49 | - | - | 0.71 | 0.82 | 1.53 | 0.75 | 1.01 | 0.81 | 1.30 | 0.71 | 0.56 | 0.84 | 0.80 | 0.62 | 0.75 |
| Sample Size | 18 | 17 | 24 | 16 | 21 | 15 | 9 | 12 | 15 | 6 | 12 | 12 | 6 | 3 | 6 | 15 | 126 | 57 | 24 | 207 |

Notes (see p.322)

- No value obtainable

TABLE V.2 The Lowest Deciles of the Distributions of Separation Distance (2.5 Nautical Miles or Less) by Sector and by Exercise Simulator Data

| | | N. Miles | | | |
|-------------|--|-------------|-------------|-------------|-------|
| | | Survey 1 | Survey 2 | Survey 3 | Total |
| SECTOR 1 | Total (2.5N.M.) | 137 | 228 | 165 | 530 |
| | Lowest Decile | 0.72 | 0.95 | 0.89 | 0.90 |
| SECTOR 2 | Total (2.5N.M.) | 158 | 183 | 197 | 538 |
| | Lowest Decile | 0.73 | 0.96 | 0.80 | 0.80 |
| SECTOR 3 | Total (2.5N.M.) | 265 | 272 | 248 | 785 |
| | Lowest Decile | 0.87 | 0.88 | 0.75 | 0.81 |
| SAMPLE SIZE | Hours | 9 | 24 | 15 | 48 |
| | Number of Separations of 2.5N.Miles or Less | 560 | 683 | 610 | 1853 |

Notes (see p.322)

TABLE V.3 The Lowest Deciles of the Distributions of Separation Distance (2.5 Nautical Miles or Less) by Sector and by Survey Sunk Data

APPENDIX V. II

Additional Graphs Accompanying Chapter 5

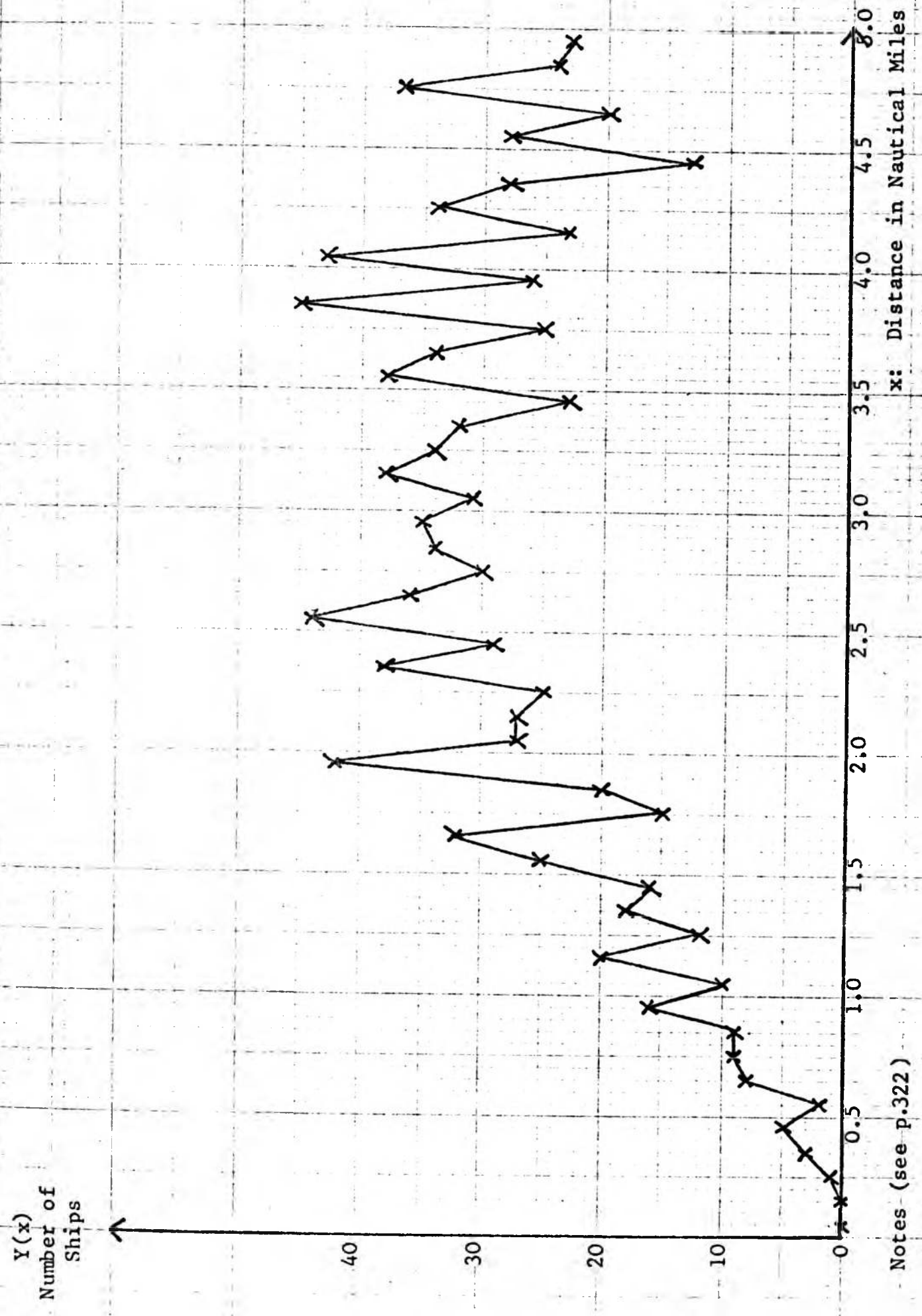

Notes (see p.322)

FIG. V.1 Simulator Data: All Exercises: Sector 2: Actual Results

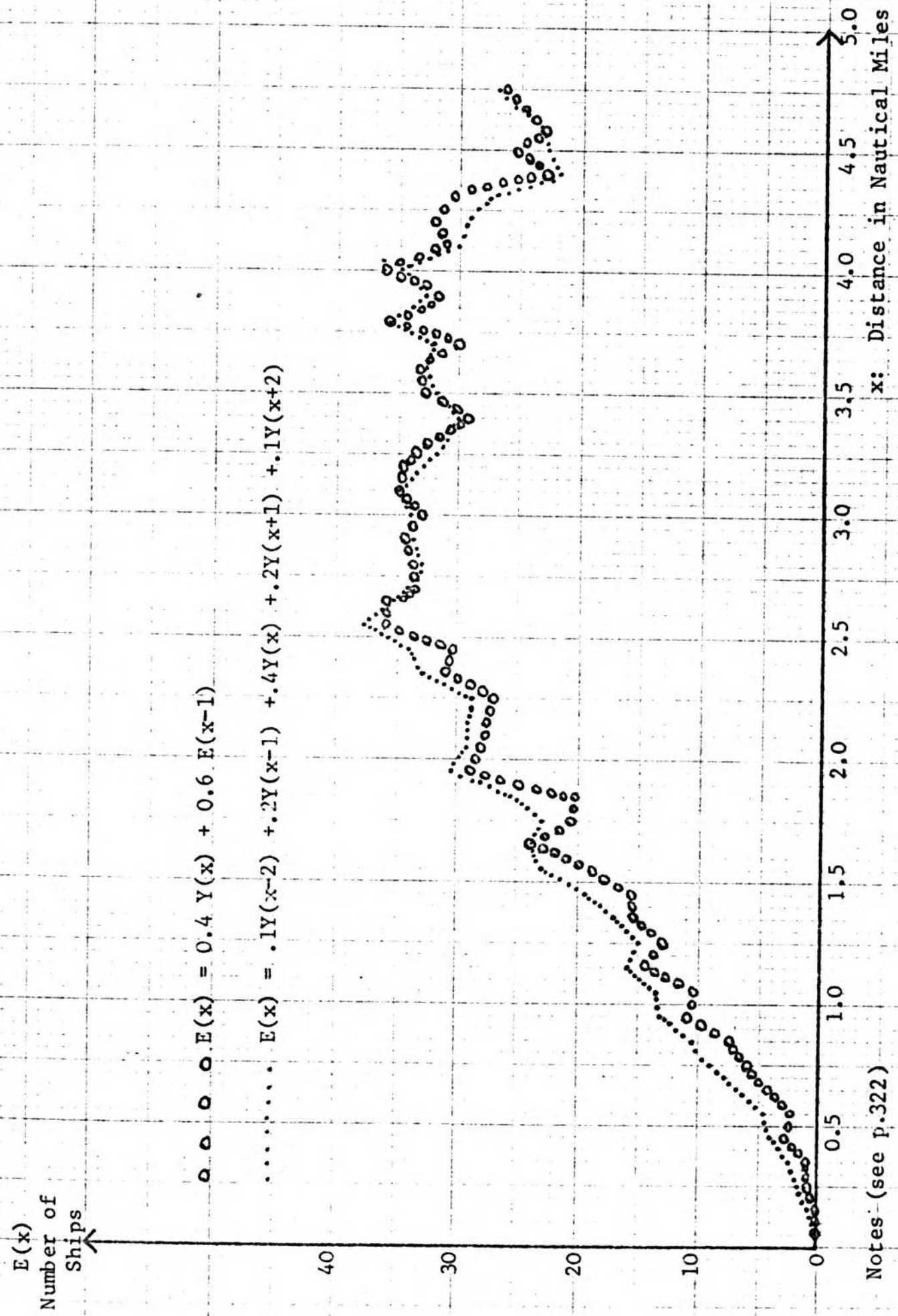
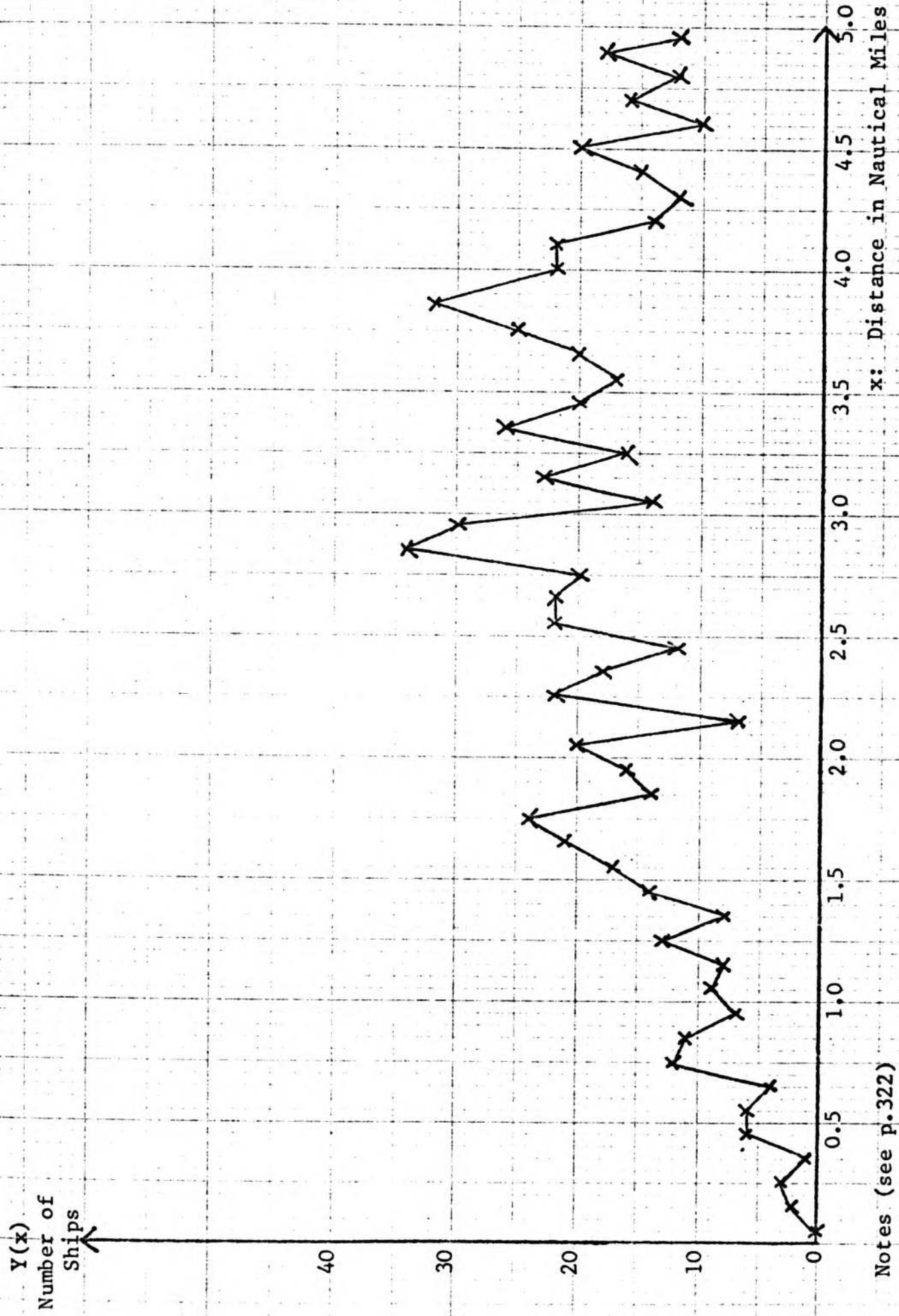

FIG. V.2 Simulator Data: All Exercises: Sector 2: Smoothed Data



Notes (see p.322)

FIG. V.3 Simulator Data: All Exercises: Sector 3: Actual Results

$E(x)$
Number of
Ships

o o o o o $E(x) = 0.4Y(x) + 0.6E(x-1)$

..... $E(x) = .1Y(x-2) + .2Y(x-1) + .4Y(x) + .2Y(x+1) + .1Y(x+2)$

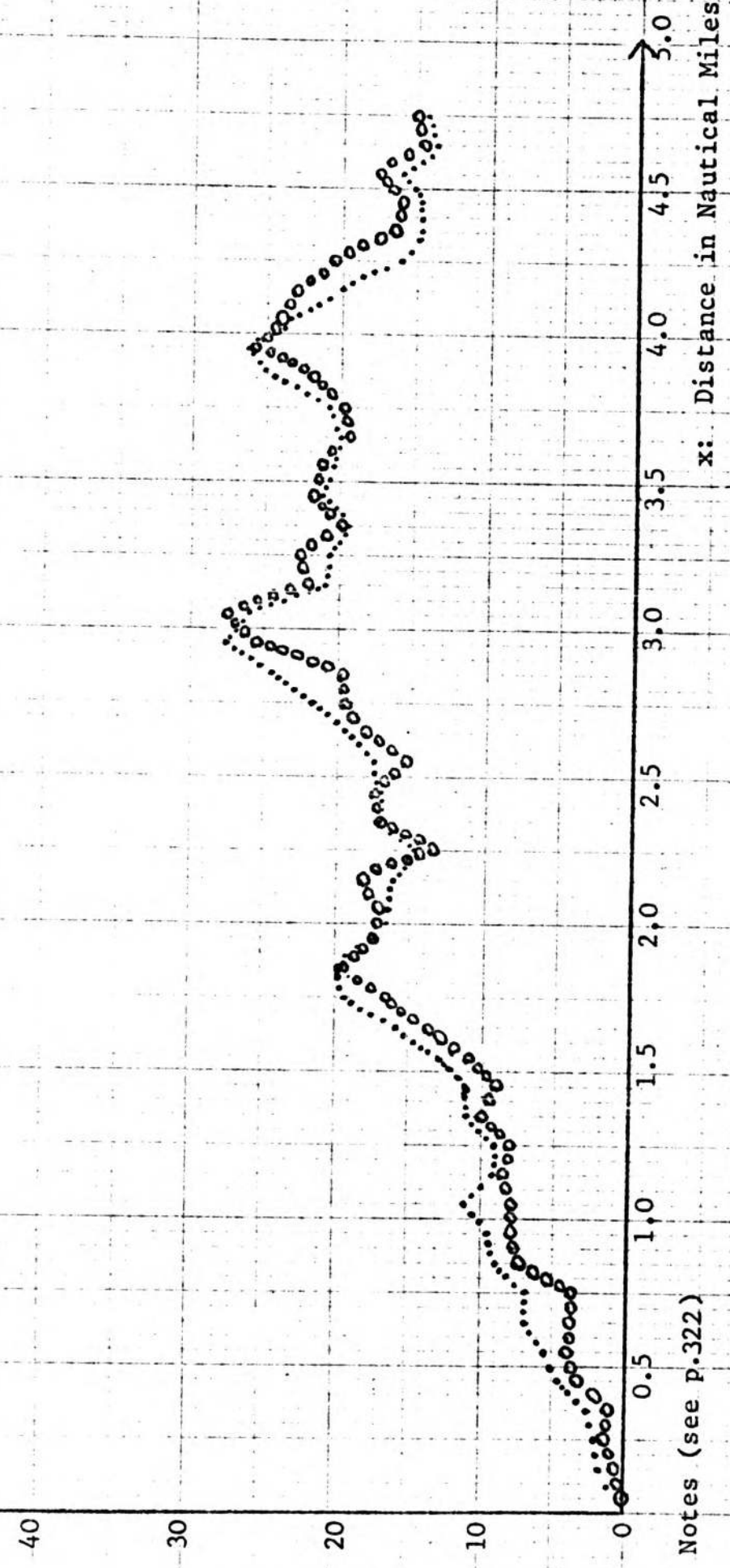

Notes (see p.322)

FIG. V.4 Simulator Data: All Exercises: Sector 3: Smoothed Data

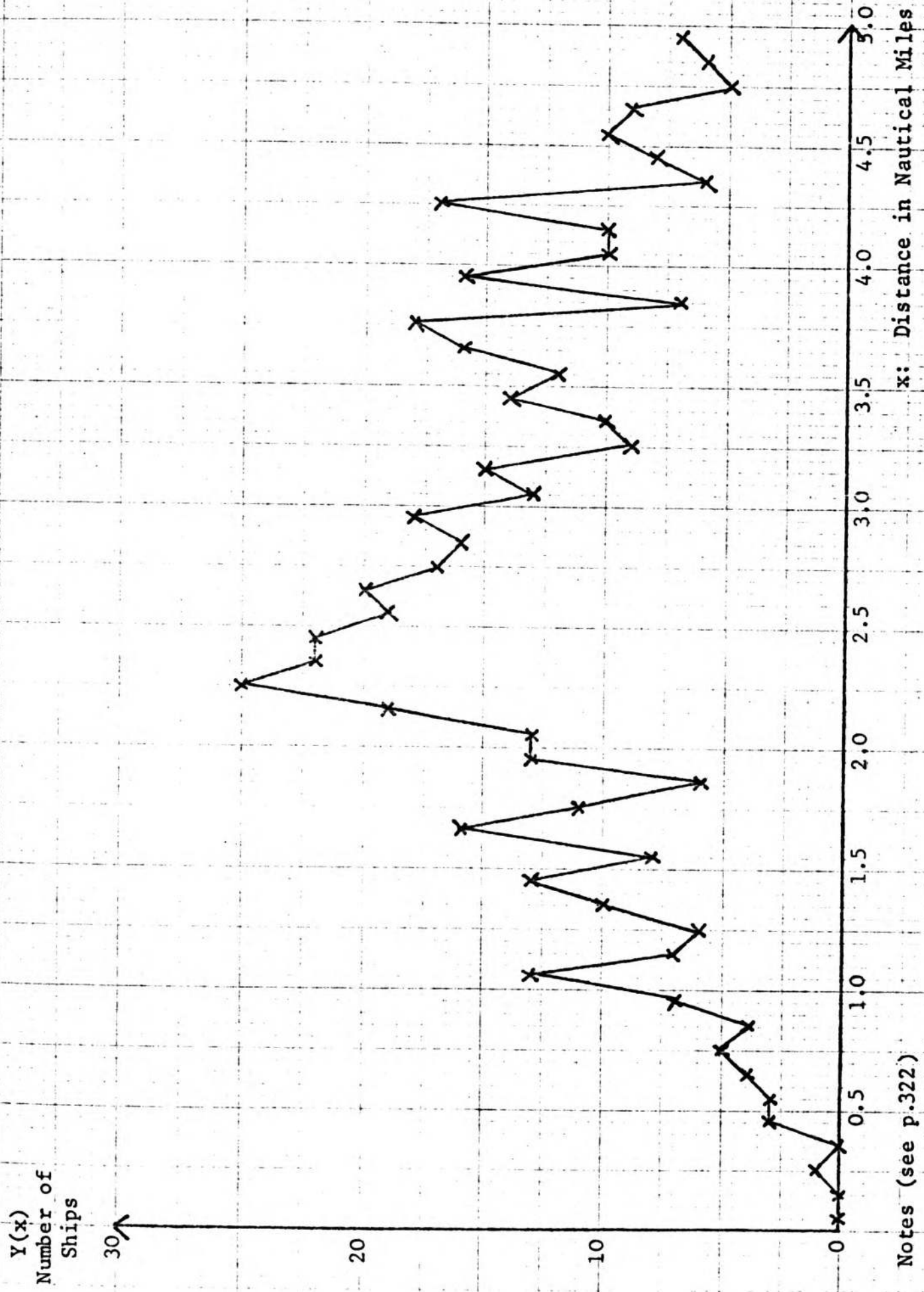

Notes (see p.322)

FIG. V.5 Sunk Survey Data: Survey 2; Sector 1: Actual Results

E(x)
Number of
Ships
30

o o o o E(x) = 0.4Y(x) + 0.6E(x-1)

..... E(x) = .1Y(x-2) + 2Y(x-1) + .4Y(x) + 2Y(x+1) + .1Y(x+2)

20

10

0

0.5 1.0 1.5 2.0 2.5 3.0 3.5 4.0 4.5 5.0

x: Distance in Nautical Miles

Notes (see p. 322)

FIG. V.6 Sunk Survey Data: Survey 2: Sector 1: Smoothed Data

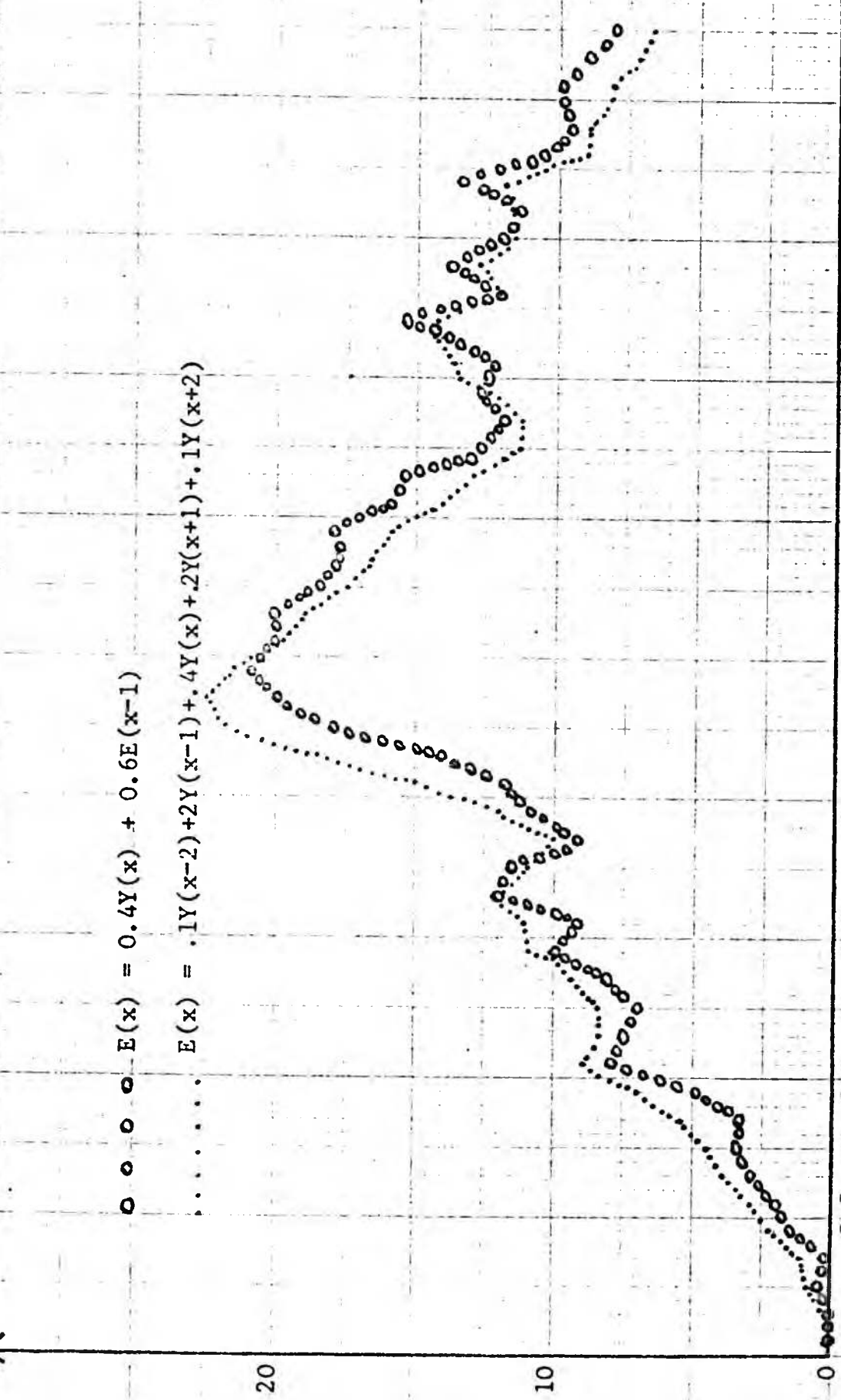

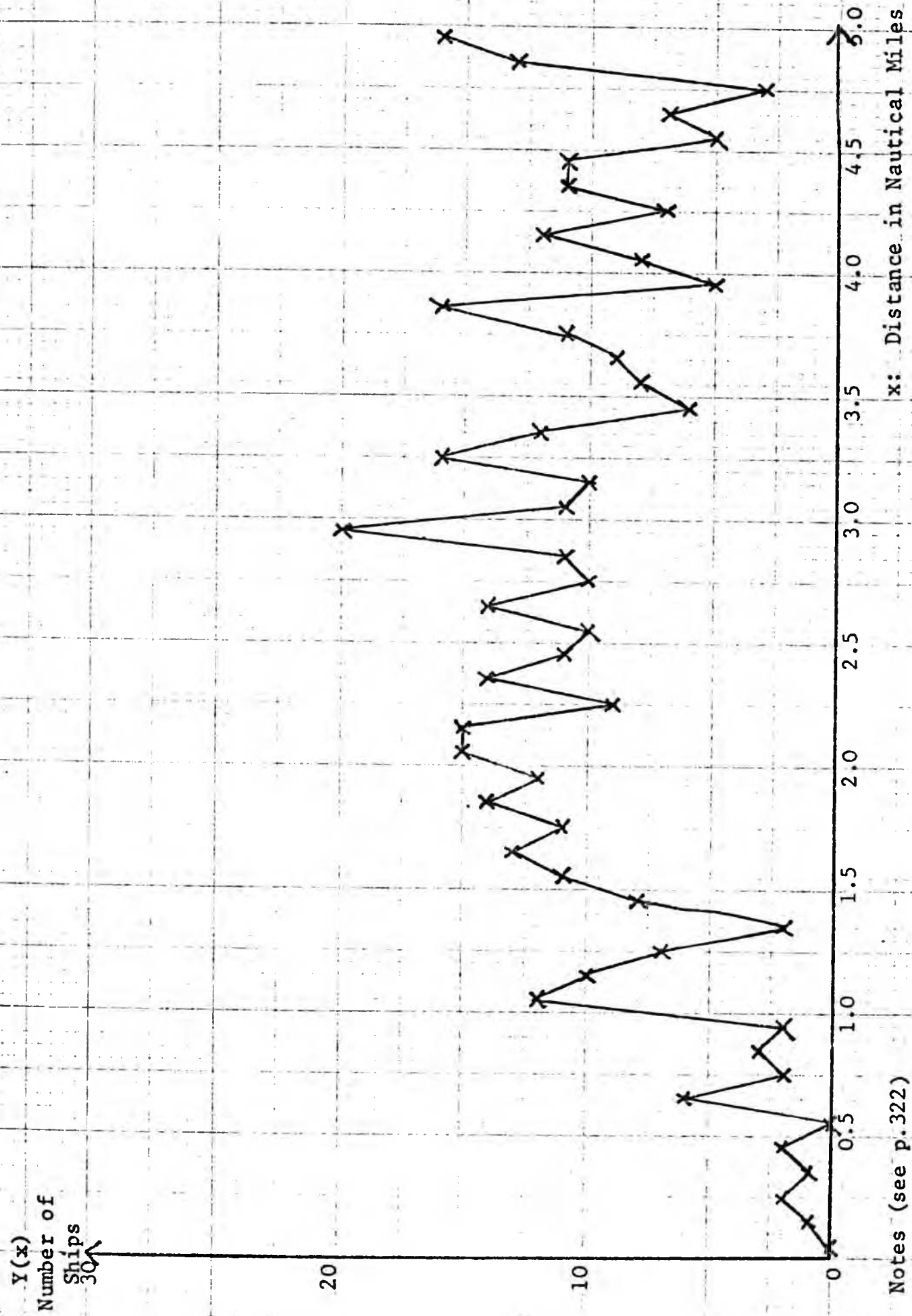

Notes (see p. 322)

FIG. V.7 Sunk Survey Data: Survey 2: Sector 2: Actual Results

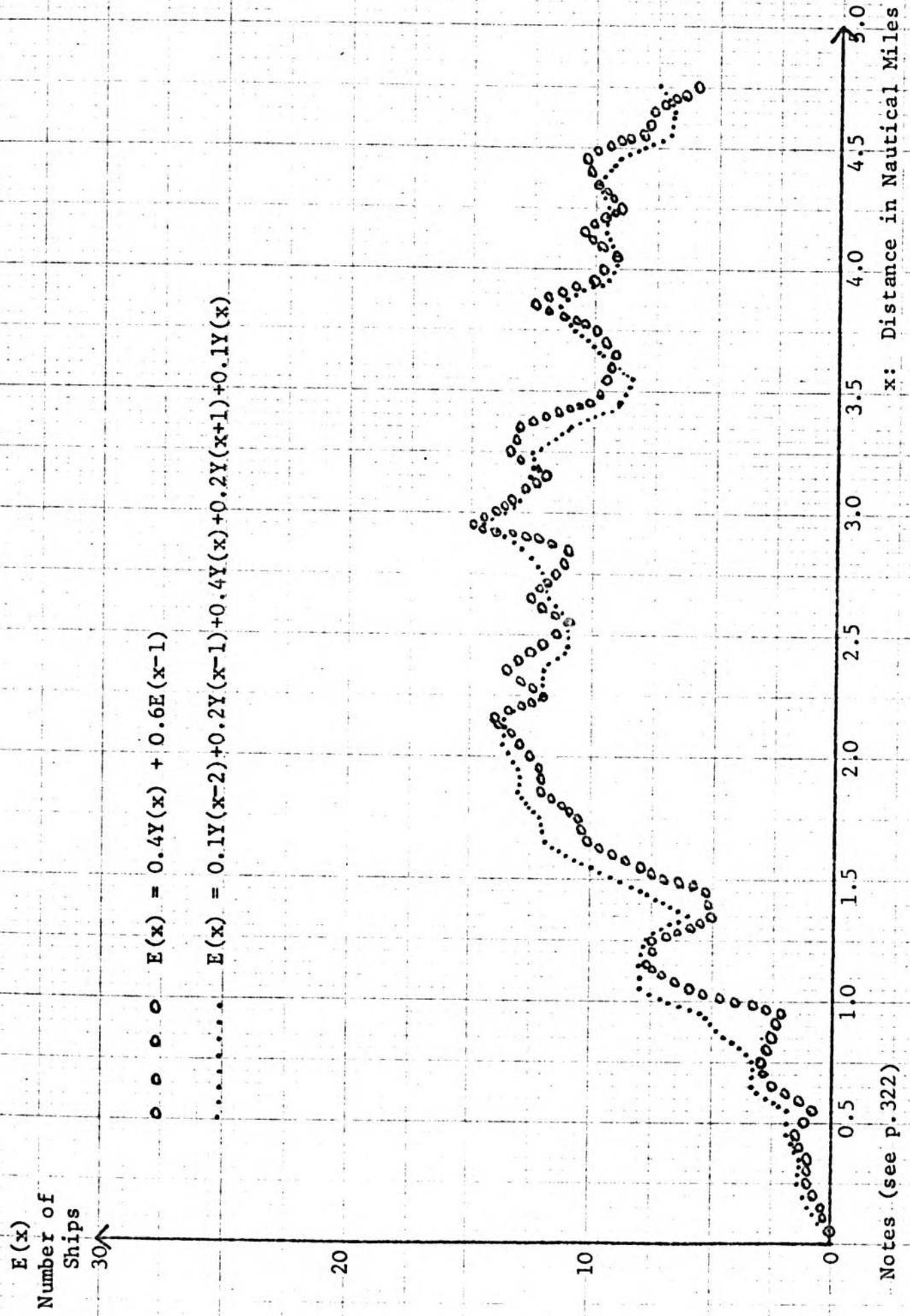

FIG. V.8 Sunk Survey Data: Survey 2: Sector 2: Smoothed Data

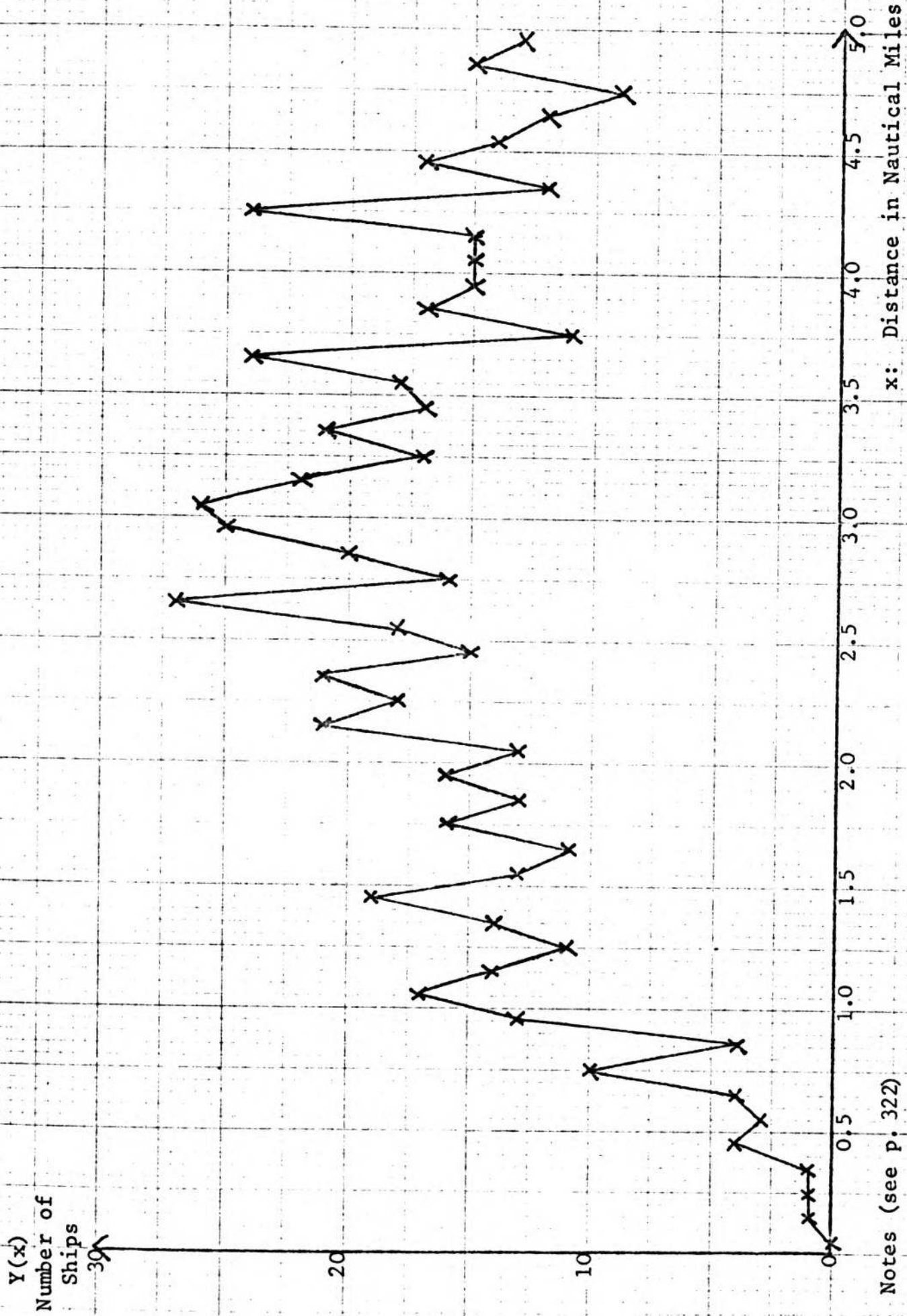

FIG. V.9 Sunk Survey Data: Survey 2: Sector 3: Actual Results

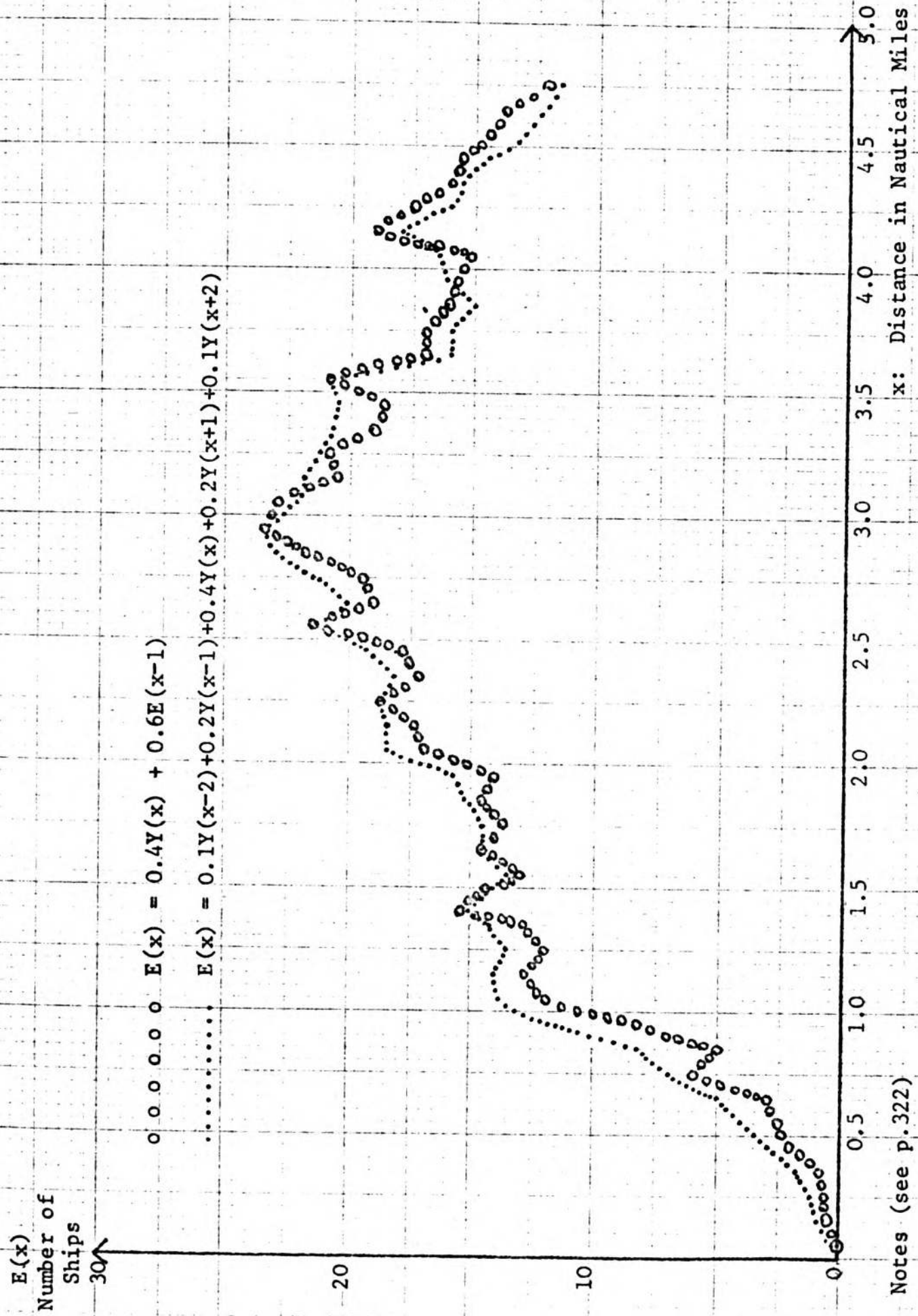

Fig. V.10 Sunk Survey Data: Survey 2: Sector 3: Smoothed Data

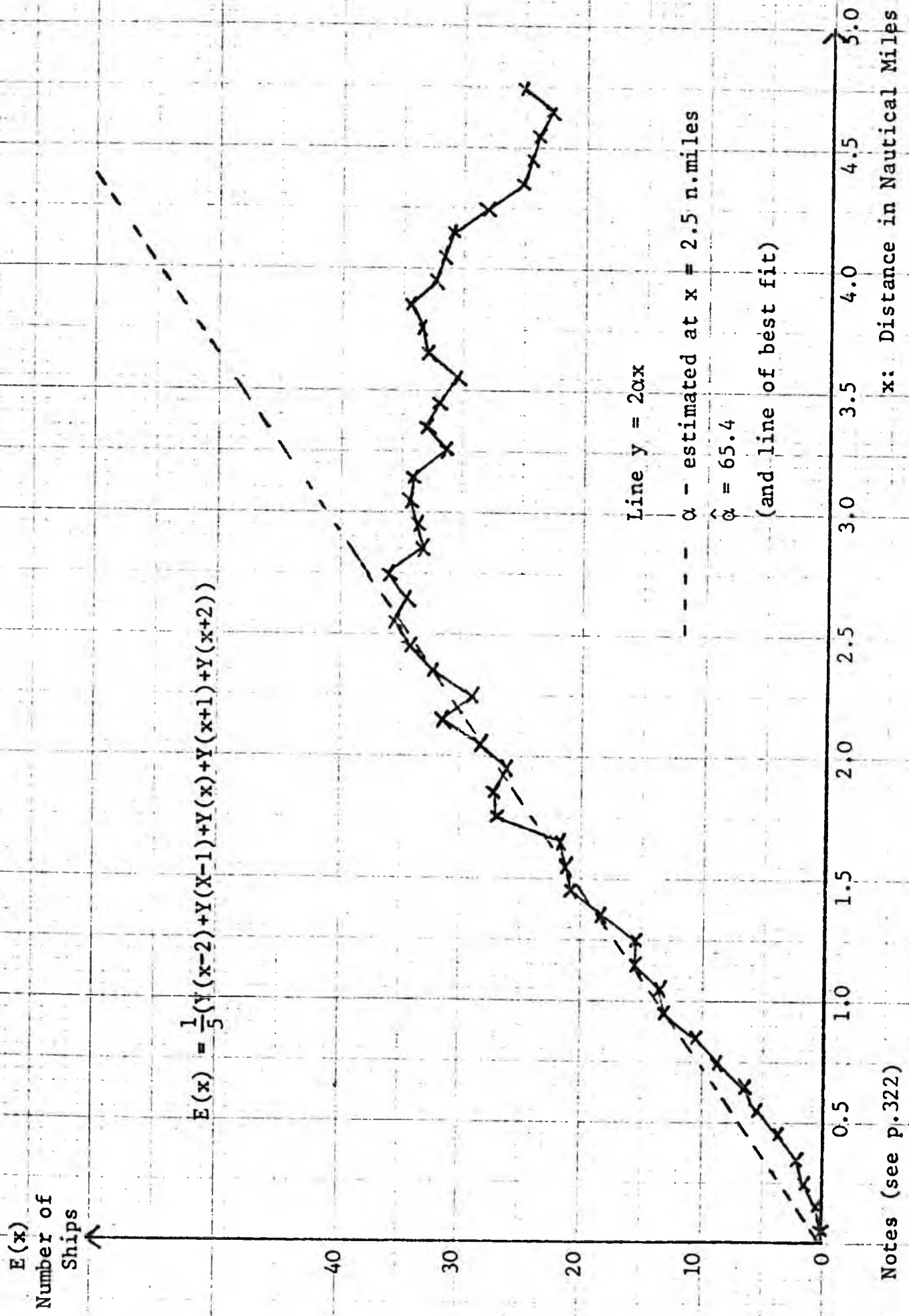
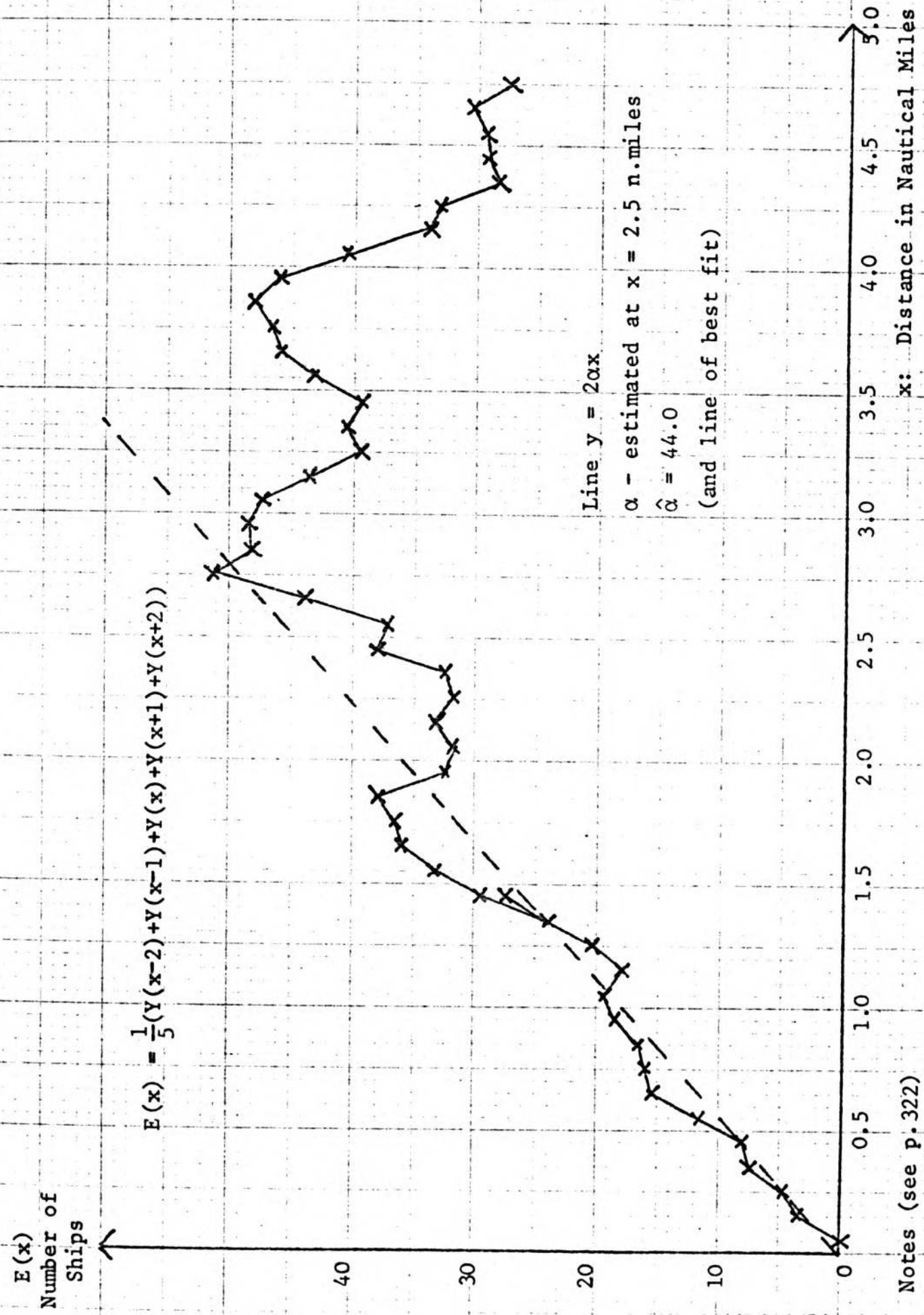
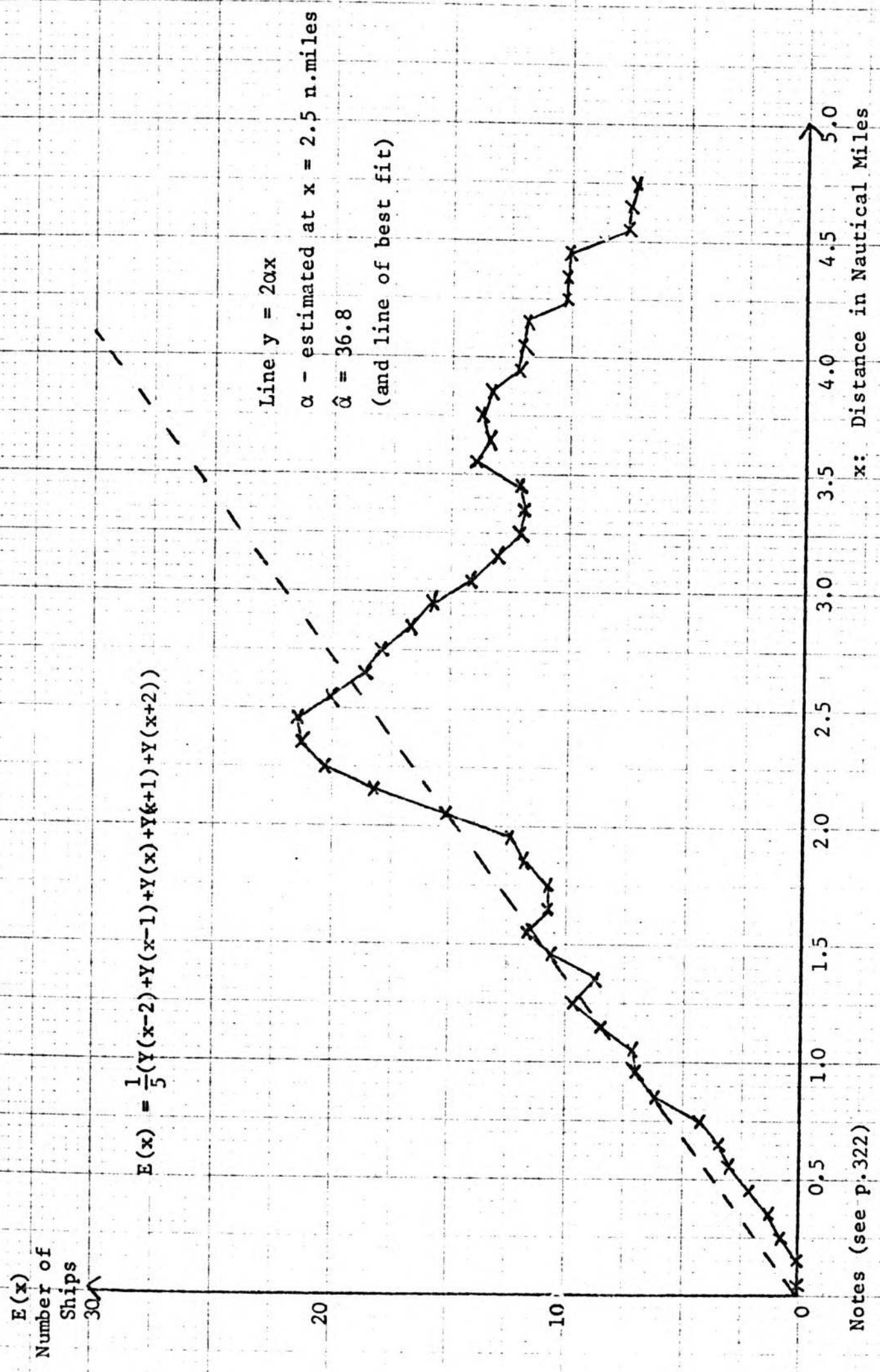

FIG. V.11 Simulator Data: All Exercises: Sector 2: Smoothed Data



Notes (see p. 322)

FIG. V.12 Simulator Data: All exercises: Sector 3: Smoothed Data



Notes (see p.322)

FIG. V.13 Sunk Survey Data: Survey 2: Sector 1: Smoothed Data

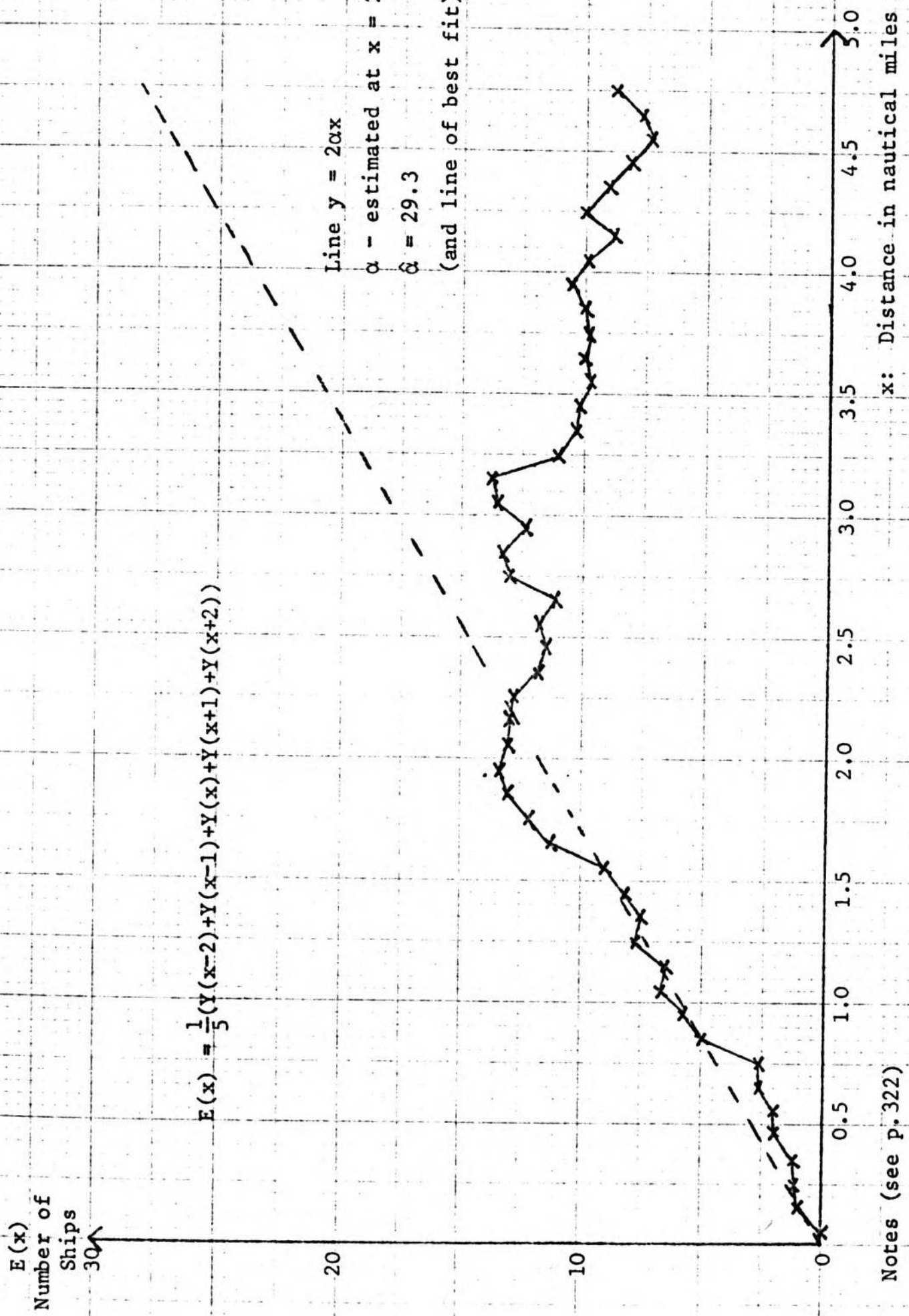

Notes (see p.322)

FIG. V.14 Sunk Survey Data: Survey 2: Sector 2: Smoothed Data

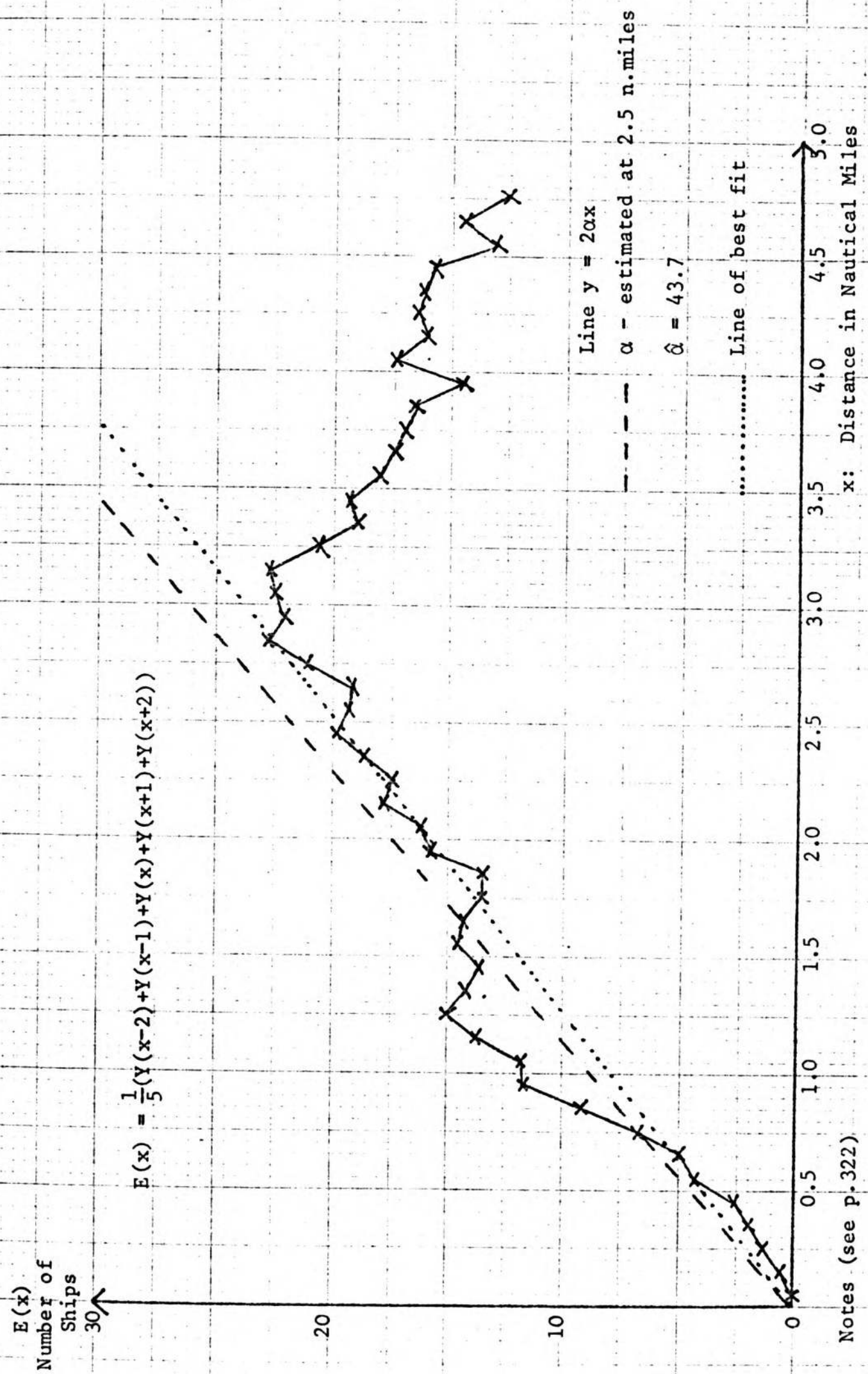

FIG. V.15 Sunk Survey Data: Survey 2: Sector 3: Smoothed Data

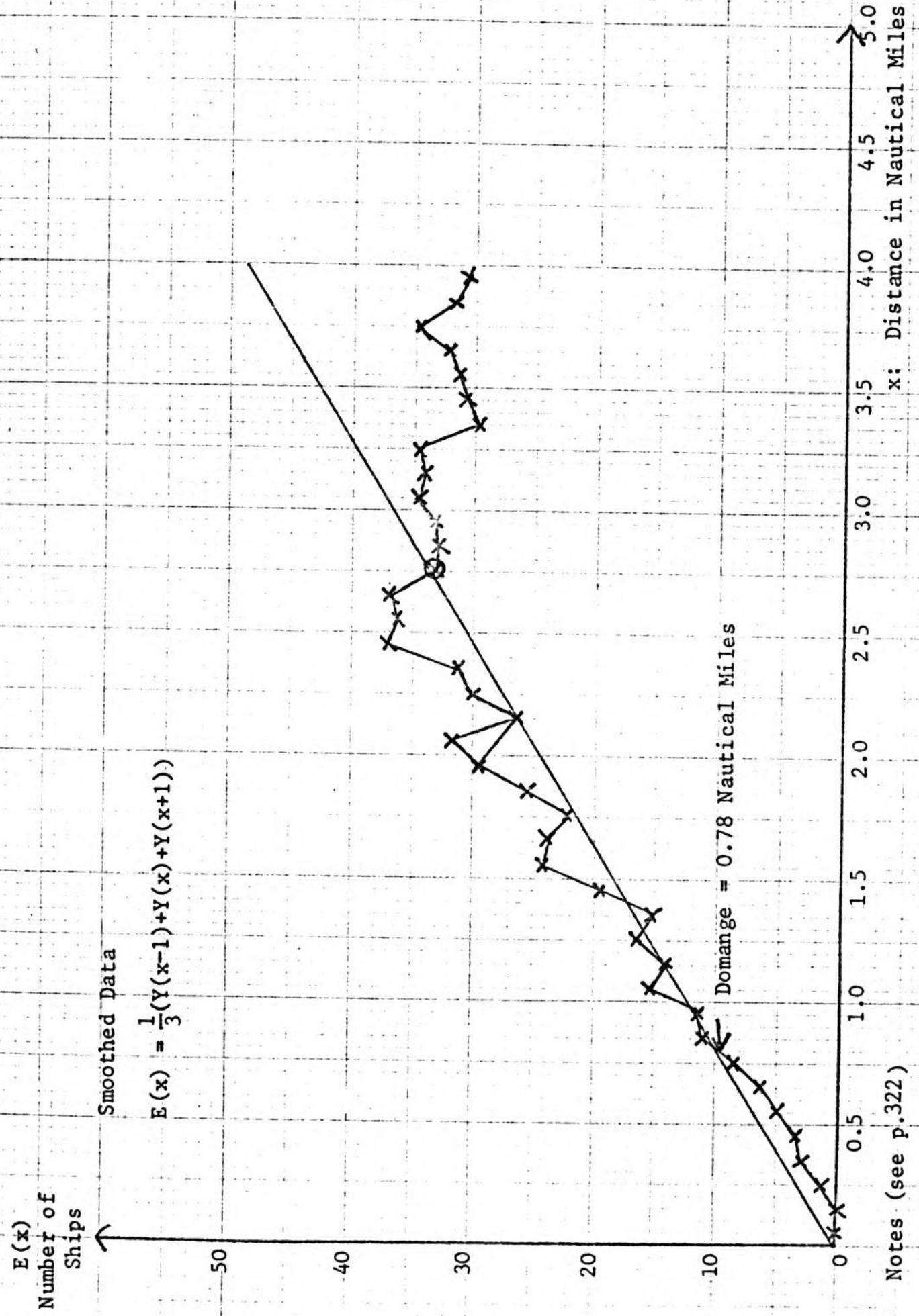
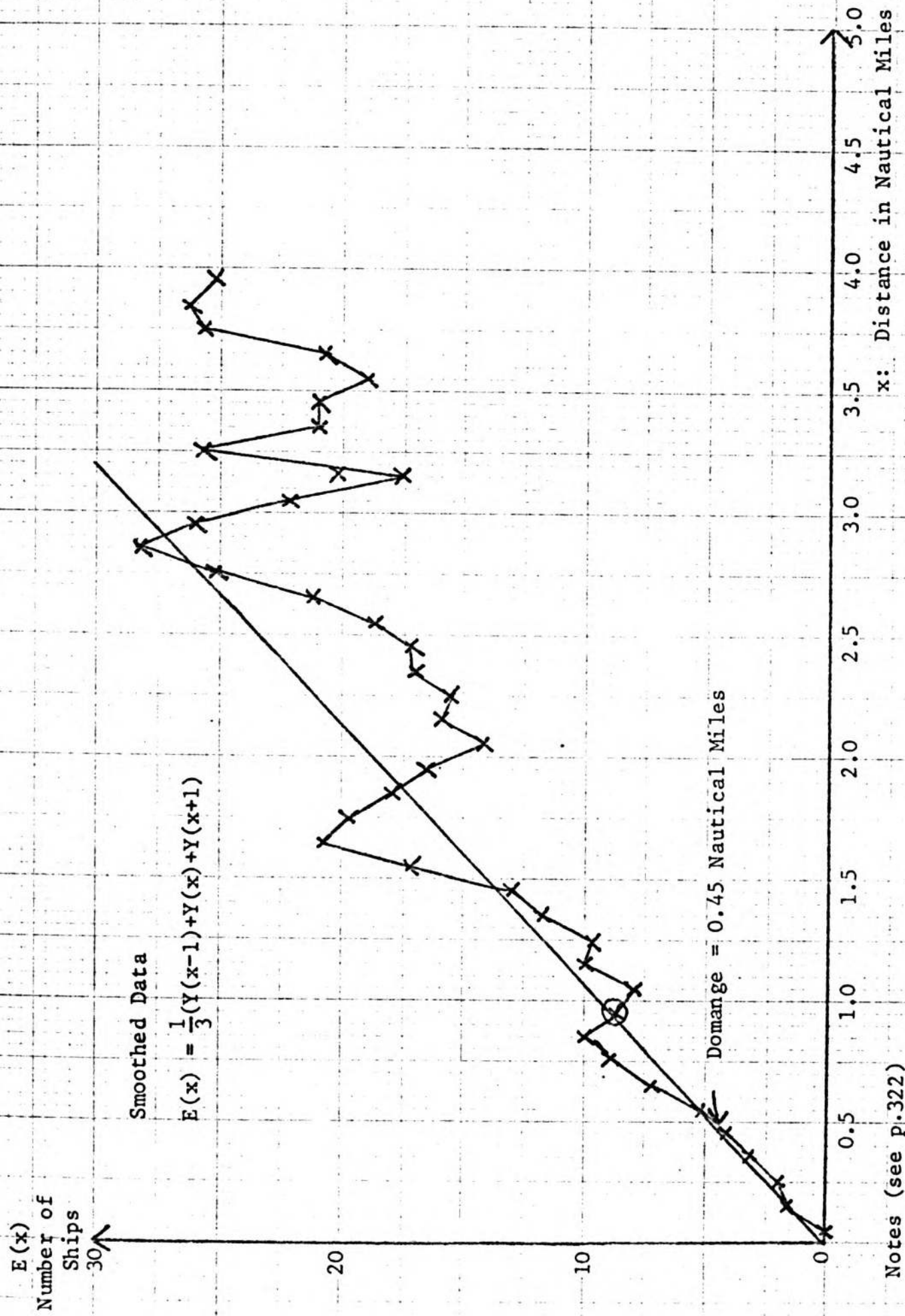
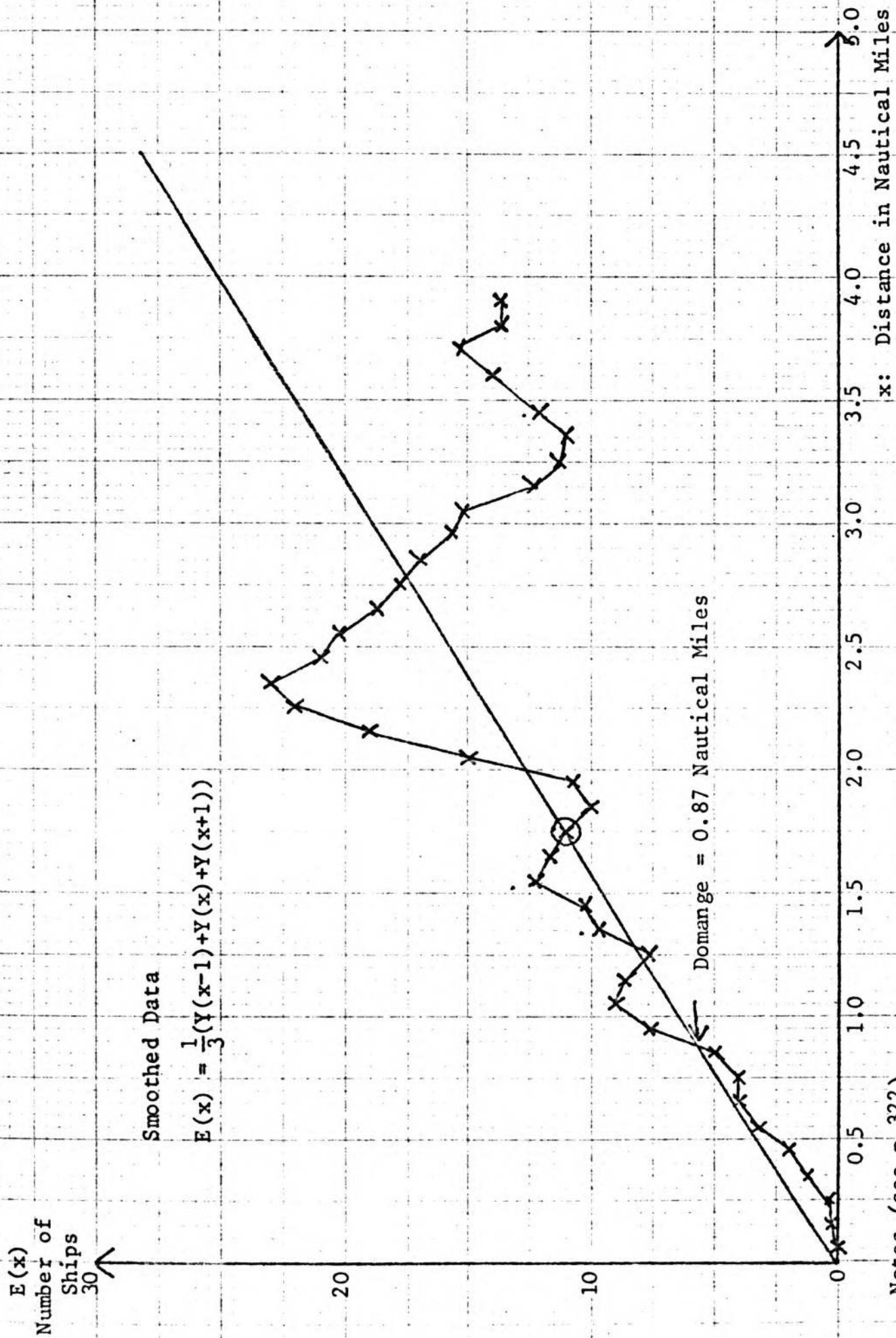

FIG. V.16 Simulator Data: All Exercises: Sector 2: Evaluation of the Domange



Notes (see p.322)

FIG. V.17 Simulator Data: All Exercises: Sector 3: Evaluation of the Domange



Notes (see p.322)

FIG. V.18 Sunk Survey Data: Survey 1: Evaluation of the Domange

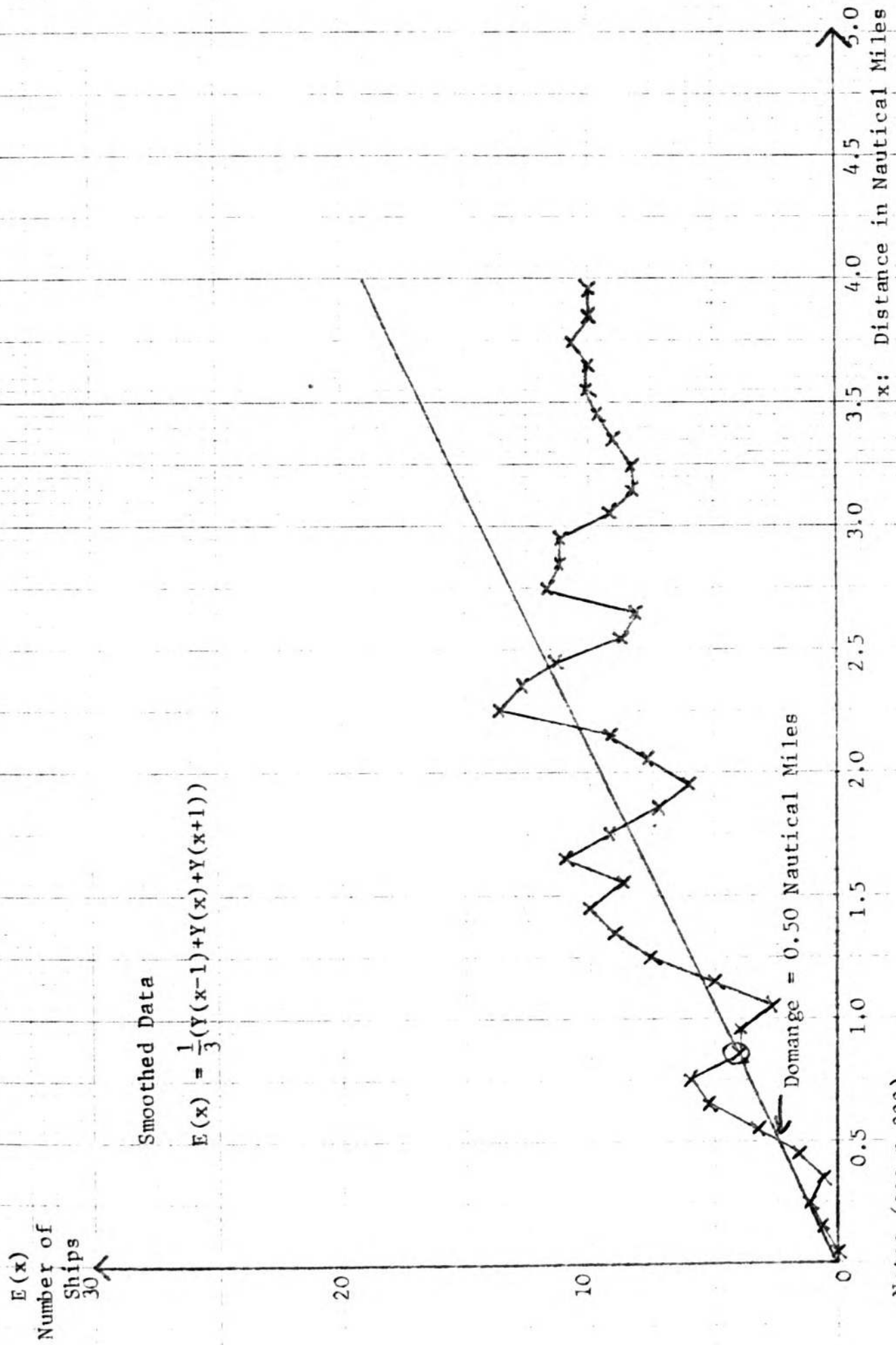

Notes (see p.322)

FIG. V.19 Sunk Survey Data: Survey 1: Sector 1: Evaluation of the Domange

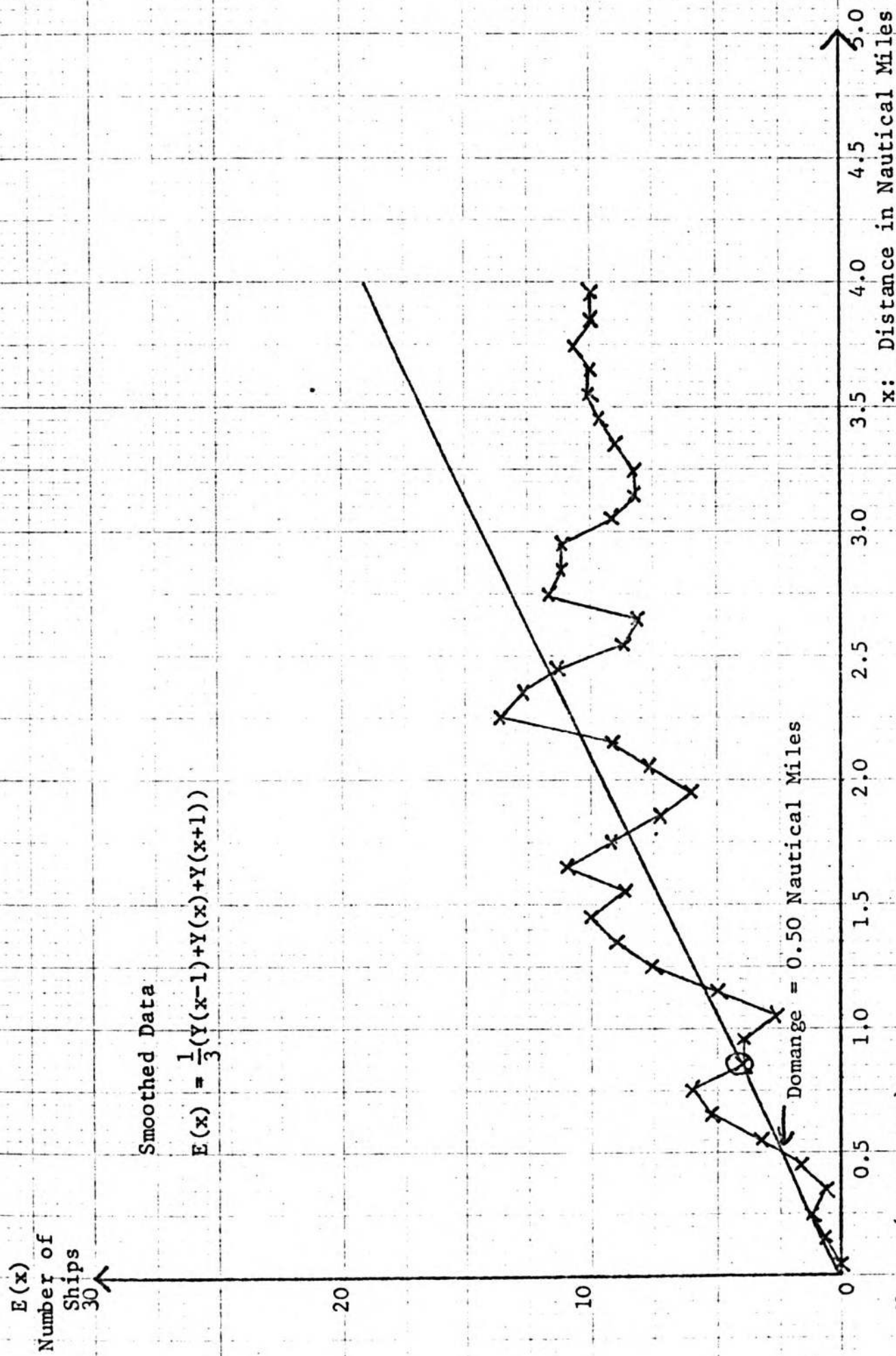

Notes (see p.322)

FIG. V.19 Sunk Survey Data: Survey 1: Sector 1: Evaluation of the Domage

APPENDIX V.III

SUMMARY OF THE METHOD OF DISPLACED NUMBERS

For all $i \quad i = 1, \dots, 50$

- (1) Note the number of ships y_i in a sector of a band of mean radius and outer radius x_i .
- (2) Smooth the data using $y_{si} = \frac{1}{3}(y_{i-1} + y_i + y_{i+1})$
- (3) Calculate $C_{si} = \sum_{k=1}^i y_{sk}$
- (4) Calculate $T_{si} = \frac{5y_{si} x_i^2}{m_i}$ (assuming $x_i - x_{i-1} = \frac{1}{10}$)
- (5) Look at sign of $T_{si} - C_{si} = \delta_i$
- (6) Initially $\delta_i = +$ for $x \leq x_c$
 $\delta_i = \overset{+}{0} \text{ or } \underset{-}{0}$ for $x \geq x_c$
- (7) Locate point $C(x_i^*, y_i^*)$ where δ_i has ceased to be consistently of one sign, ignoring fluctuations at small values of x_i where less than 10 ships are involved.
- (8) Plot (x_i, y_{si}) .
- (9) Join (x_i^*, y_i^*) to the origin.
- (10) The domange x_A can be read from the point of intersection of the line and the curve of plotted points

Plot is in

APPENDIX V. IV

Examples of the Full Calculations Using the Method of Displaced Numbers

| $\frac{x_i}{10N.Miles}$ | $\frac{m_i}{20N.Miles}$ | $\frac{5x_i^2}{m_i} = \lambda_i$ | y_{si} | $C_{si} = \Sigma y_{si}$ | $T_{si} = \lambda_i y_{si}$ | Sign of $T_{si} - C_{si}$ |
|-------------------------|-------------------------|----------------------------------|----------|--------------------------|-----------------------------|---------------------------|
| 1 | 1 | 1.000 | 0 | 0 | 0 | |
| 2 | 3 | 1.333 | 0.3 | 0.3 | 0.4 | + |
| 3 | 5 | 1.800 | 0.7 | 1.0 | 1.2 | + |
| 4 | 7 | 2.286 | 2.3 | 3.3 | 5.3 | + |
| 5 | 9 | 2.778 | 4.0 | 7.3 | 11.1 | + |
| 6 | 11 | 3.273 | 6.0 | 13.3 | 19.6 | + |
| 7 | 13 | 3.769 | 7.3 | 20.7 | 27.6 | + |
| 8 | 15 | 4.267 | 8.0 | 28.7 | 34.1 | + |
| 9 | 17 | 4.765 | 8.3 | 37.0 | 39.7 | + |
| 10 | 19 | 5.263 | 8.3 | 45.3 | 43.9 | - * |
| 11 | 21 | 5.762 | 9.3 | 54.7 | 53.6 | - |
| 12 | 23 | 6.261 | 11.7 | 66.3 | 73.0 | + |
| 13 | 25 | 6.760 | 12.0 | 78.3 | 81.1 | + |
| 14 | 27 | 7.259 | 12.0 | 90.3 | 87.1 | - |
| 15 | 29 | 7.759 | 11.0 | 101.3 | 85.3 | - |
| 16 | 31 | 8.258 | 13.7 | 115.0 | 112.9 | - |
| 17 | 33 | 8.758 | 15.3 | 130.3 | 134.3 | + |
| 18 | 35 | 9.257 | 16.0 | 146.3 | 148.1 | + |
| 19 | 37 | 9.757 | 14.7 | 161.0 | 143.1 | - |
| 20 | 39 | 10.256 | 13.7 | 174.7 | 140.2 | - |
| 21 | 41 | 10.756 | 12.7 | 187.3 | 136.2 | - |
| 22 | 43 | 11.256 | 12.7 | 200.0 | 142.6 | - |
| 23 | 45 | 11.756 | 13.3 | 213.3 | 156.7 | - |
| 24 | 47 | 12.255 | 16.3 | 229.7 | 200.2 | - |
| 25 | 49 | 12.755 | 17.7 | 247.3 | 225.3 | - |

Notes (see p.322)

* $(x_i^*, y_i^*) = (0.95, 8.3)$ point C

TABLE V.4 Calculation of the Domain Boundary Sunk Data:
Survey 3: Sector 3

| $\frac{x_i}{10}$ N.Miles | $\frac{m_i}{20}$ N.Miles | $\frac{5x_i^2}{m_i} = \lambda_i$ | y_{si} | $C_{si} = \sum y_{si}$ | $T_{si} = \lambda_i y_{si}$ | Sign of $T_{si} - C_{si}$ |
|--------------------------|--------------------------|----------------------------------|----------|------------------------|-----------------------------|---------------------------|
| 1 | 1 | 1.000 | 0 | 0 | 0 | + |
| 2 | 3 | 1.333 | 2.3 | 2.3 | 3.0 | + |
| 3 | 5 | 1.800 | 2.3 | 4.7 | 4.1 | - |
| 4 | 7 | 2.286 | 2.0 | 6.7 | 4.6 | - |
| 5 | 9 | 2.778 | 1.7 | 8.3 | 4.7 | - |
| 6 | 11 | 3.273 | 2.3 | 10.7 | 7.5 | - |
| 7 | 13 | 3.769 | 3.7 | 14.3 | 13.9 | - |
| 8 | 15 | 4.267 | 5.7 | 20.0 | 24.3 | + |
| 9 | 17 | 4.765 | 9.0 | 29.0 | 42.9 | + |
| 10 | 19 | 5.263 | 10.0 | 39.0 | 52.6 | + |
| 11 | 21 | 5.762 | 12.3 | 51.3 | 70.9 | + |
| 12 | 23 | 6.261 | 13.7 | 65.0 | 85.8 | + |
| 13 | 25 | 6.760 | 16.0 | 81.0 | 108.2 | + |
| 14 | 27 | 7.259 | 16.3 | 97.3 | 118.3 | + |
| 15 | 29 | 7.759 | 16.7 | 114.0 | 129.6 | + |
| 16 | 31 | 8.258 | 20.3 | 134.3 | 167.6 | + |
| 17 | 33 | 8.758 | 24.0 | 158.3 | 210.2 | + |
| 18 | 35 | 9.257 | 26.3 | 184.7 | 243.5 | + |
| 19 | 37 | 9.757 | 27.3 | 212.0 | 266.4 | + |
| 20 | 39 | 10.256 | 26.3 | 238.3 | 269.7 | + |
| 21 | 41 | 10.756 | 27.3 | 265.7 | 293.6 | + |
| 22 | 43 | 11.256 | 27.3 | 293.0 | 307.3 | + |
| 23 | 45 | 11.756 | 27.0 | 320.0 | 317.4 | - * |
| 24 | 47 | 12.255 | 26.7 | 346.7 | 327.2 | - |
| 25 | 49 | 12.755 | 28.0 | 374.7 | 357.1 | - |
| 26 | 51 | 13.255 | 30.3 | 405.0 | 401.6 | - |
| 27 | 53 | 13.755 | 30.7 | 435.7 | 422.2 | - |
| 28 | 55 | 14.255 | 28.3 | 464.0 | 403.4 | - |
| 29 | 57 | 14.754 | 30.3 | 494.3 | 447.0 | - |
| 30 | 59 | 15.254 | 32.7 | 527.0 | 498.8 | - |

Notes (see p.322)

* $(x_i^*, y_i^*) = (2.25, 27)$ point C

TABLE V.5 Calculation of the Domange Simulator Data:
All Exercises: Sector 1

| $\frac{1}{10N} x_i$ 10N.Miles | $\frac{1}{20N} m_i$ 20N.Miles | $\frac{5x_i^2}{m_i} = \lambda_i$ | y_{si} | $C_{si} = \Sigma y_{si}$ | $T_{si} = \lambda_i y_{si}$ | Sign of $T_{si} - C_{si}$ | y_i un smoothed |
|----------------------------------|----------------------------------|----------------------------------|----------|--------------------------|-----------------------------|------------------------------|----------------------|
| 1 | 1 | 1.000 | 0 | 0 | 0 | | 0 |
| 2 | 3 | 1.333 | 0 | 0 | 0 | | 0 |
| 3 | 5 | 1.800 | 0.7 | 0.7 | 1.3 | + | 0 |
| 4 | 7 | 2.286 | 1.7 | 2.3 | 3.9 | + | 2 |
| 5 | 9 | 2.778 | 2.0 | 4.3 | 5.6 | + | 3 |
| 6 | 11 | 3.273 | 3.3 | 7.7 | 10.8 | + | 1 |
| 7 | 13 | 3.769 | 3.7 | 11.3 | 12.4 | + | 6 |
| 8 | 15 | 4.267 | 5.7 | 17.0 | 24.3 | + | 4 |
| 9 | 17 | 4.765 | 5.7 | 22.7 | 27.2 | + | 7 |
| 10 | 19 | 5.263 | 6.0 | 28.7 | 31.6 | + | 6 |
| 11 | 21 | 5.762 | 7.3 | 36.0 | 42.1 | + | 5 |
| 12 | 23 | 6.261 | 7.0 | 43.0 | 43.8 | + | 11 |
| 13 | 25 | 6.760 | 8.0 | 51.0 | 54.1 | + | 5 |
| 14 | 27 | 7.259 | 7.3 | 58.3 | 53.0 | - | 8 |
| 15 | 29 | 7.759 | 11.7 | 70.0 | 90.8 | + | 9 |
| 16 | 31 | 8.258 | 13.3 | 83.3 | 109.8 | + | 18 |
| 17 | 33 | 8.758 | 13.0 | 96.3 | 113.8 | + | 13 |
| 18 | 35 | 9.257 | 12.0 | 108.3 | 111.1 | + | 8 |
| 19 | 37 | 9.757 | 14.3 | 122.7 | 139.5 | + | 15 |
| 20 | 39 | 10.256 | 19.0 | 141.7 | 194.8 | + | 20 |
| 21 | 41 | 10.756 | 20.0 | 161.7 | 215.1 | + | 22 |
| 22 | 43 | 11.256 | 18.0 | 179.7 | 202.6 | + | 18 |
| 23 | 45 | 11.756 | 19.7 | 199.3 | 231.6 | + | 14 |
| 24 | 47 | 12.255 | 18.7 | 218.0 | 229.2 | + | 27 |
| 25 | 49 | 12.755 | 22.0 | 240.0 | 280.6 | + | 15 |
| 26 | 51 | 13.255 | 17.7 | 257.7 | 234.6 | - * | 24 |
| 27 | 53 | 13.755 | 19.0 | 276.7 | 261.3 | - | 14 |
| 28 | 55 | 14.255 | 17.0 | 293.7 | 242.3 | - | 19 |
| 29 | 57 | 14.754 | 16.3 | 310.0 | 240.5 | - | 18 |
| 30 | 59 | 15.254 | 17.3 | 327.3 | 263.0 | - | 12 |

Notes (see p.322)

* $(x_i^*, y_i^*) = (2.55, 17.7)$ point C

TABLE V.6 Calculation of the Domange Simulator Data:
Gibraltar: Sector 2

EXAMPLE OF THE SLOPE METHOD FOR LOCATING THE DOMANGE

| $\frac{1}{10} x_i$ N.Mile | $\hat{\alpha}$ | $\frac{1}{10} x_i$ N.Mile | $\hat{\alpha}$ | $\frac{1}{10} x_i$ N.Mile | $\hat{\alpha}$ |
|------------------------------|----------------|------------------------------|----------------|------------------------------|----------------|
| 1 | 0 | 11 | 45.5 | 21 | 42.6 |
| 2 | 25.0 | 12 | 45.1 | 22 | 41.1 |
| 3 | 11.1 | 13 | 47.3 | 23 | 40.5 |
| 4 | 12.5 | 14 | 46.4 | 24 | 39.6 |
| 5 | 32.0 | 15 | 44.9 | 25 | 39.7 |
| 6 | 36.1 | 16 | 44.1 | 26 | 39.5 |
| 7 | 40.8 | 17 | 45.7 | 27 | 39.0 |
| 8 | 46.9 | 18 | 45.4 | 28 | 38.7 |
| 9 | 45.7 | 19 | 44.6 | 29 | 38.6 |
| 10 | 45.0 | 20 | 44.0 | 30 | 37.6 |

Notes (see p.322)

TABLE V.7 Estimates of the Slope of the Line of Uniform Density for the Calculation of the Domange by the Slope Method: Sunk Survey Data: Survey 3: Sector 3.

$$\hat{\alpha} = \frac{C_i}{x_i^2} \quad \text{where } C_i \text{ is the cumulative total of ships in the area bounded by the sector of the circle of outer radius } x_i.$$

For $x_i \leq 1.3$ $\hat{\alpha}$ can be considered to be increasing

For $x_i > 1.7$ $\hat{\alpha}$ can be considered to be decreasing

$\therefore \hat{\alpha}$ is stable for $1.4 \leq x_i \leq 1.7$

\therefore Mean value of $\hat{\alpha}$, $\bar{\alpha} = 45.3$

and point C is to be located at $x_i \approx 1.35$ n.miles.

This situation was drawn in Fig. 5.9 where by the method of displaced numbers, point C was located at $x_i = 0.95$ n.miles and $\hat{\alpha}$ was taken to be equal to 44.0. However, the value for the number of ships at $x_i = 1.35$ also lies on the line drawn so this is the second point which could be C under this method. Thus the slope method provides useful support for the results found by the method of displaced numbers.

APPENDIX V.VI

Calculations for the Standard Errors of the Domanges

| SITUATION | Domain Boundary in Nautical Miles | Cumulative Total To C _c | Variance σ^2 | Number Displaced \hat{n} | Standard Error $\hat{\sigma}/\sqrt{n}$ in Nautical Miles |
|----------------|-----------------------------------|------------------------------------|---------------------|----------------------------|--|
| SIMULATOR DATA | | | | | |
| All Exercises | | | | | |
| Sector 1 | 1.33 | 324 | .25 | 77 | .056 |
| Sector 2 | 0.78 | 519 | .37 | 42 | .093 |
| Sector 3 | 0.45 | 52 | .05 | 13 | .062 |
| Dover Strait | | | | | |
| Sector 1 | 0.82 | 63 | .11 | 18 | .078 |
| Sector 2 | 0.77 | 36 | .06 | 16 | .061 |
| Sector 3 | 0.10 | 8 | .01 | 0.3 | .207 |
| Gibraltar | | | | | |
| Sector 1 | 1.49 | 146 | .21 | 62 | .059 |
| Sector 2 | 1.40 | 261 | .31 | 76 | .064 |
| Sector 3 | 0.57 | 27 | .05 | 8 | .078 |
| Open Ocean | | | | | |
| Sector 1 | 2.35 | 225 | .20 | 85 | .049 |
| Sector 2 | 2.35 | 275 | .60 | 94 | .080 |
| Sector 3 | 0.85 | 13 | .08 | 5 | .122 |
| SUNK DATA | | | | | |
| Survey 1 | | | | | |
| Sector 1 | 0.47 | 17 | .03 | 7 | .062 |
| Sector 2 | 0.50 | 25 | .04 | 8 | .072 |
| Sector 3 | 0.35 | 23 | .01 | 6 | .043 |
| Survey 2 | | | | | |
| Sector 1 | 0.87 | 110 | .14 | 28 | .072 |
| Sector 2 | 0.91 | 48 | .09 | 23 | .063 |
| Sector 3 | 0.78 | 129 | .11 | 32 | .057 |
| Survey 3 | | | | | |
| Sector 1 | 0.71 | 83 | .11 | 14 | .088 |
| Sector 2 | 0.58 | 80 | .07 | 15 | .069 |
| Sector 3 | 0.45 | 37 | .02 | 16 | .031 |
| All Surveys | | | | | |
| Sector 1 | 0.85 | 240 | .14 | 67 | .045 |
| Sector 2 | 0.70 | 185 | .10 | 46 | .045 |
| Sector 3 | 0.45 | 303 | .10 | 34 | .055 |

Notes (see p.322)

TABLE V.8 Calculations for the Standard Error of the Domain Boundary in Different Situations
 A: Simulator Data: by Sector and by Type of Sea Area
 B: Sunk Data: by Sector and by Survey

APPENDIX VI.I

THE KRUSKAL-WALLIS ONE-WAY ANALYSIS OF VARIANCE

The Kruskal-Wallis one-way analysis of variance is a test for deciding whether K independent samples belong to the same population or different populations. In the test all the observations are treated as belonging to one large sample and within that large sample each observation is replaced by its appropriate rank in ascending order. The sum of the ranks for the observations in each of the K individual samples is then calculated and hence a value of the test statistic H.

$$H = \frac{12}{N(N+1)} \sum_{j=1}^K \frac{R_j^2}{n_j} - 3(N+1)$$

where R_j is the sum of the ranks for the j^{th} sample

n_j is the number of observations in the j^{th} sample

N is the total number of observations i.e. $N = \sum_{j=1}^K n_j$

Under a null hypothesis that the K populations from which the K samples are drawn respectively, are equivalent to one population then H is distributed as χ^2 with k-1 degrees of freedom, provided the n_j 's are sufficiently large (≥ 6).

Since each observation is replaced by a ranking the test is equivalent to testing whether the medians of all the K populations are the same. Thus the null hypothesis H_0 can be expressed:

$$\tilde{x}_1 = \tilde{x}_2 = \dots = \tilde{x}_K$$

and the alternative hypothesis H_1 can be expressed:-

$$\tilde{x}_i \neq \tilde{x}_j \text{ for at least one pair of values } i, j \quad \left. \begin{array}{l} i = 1 \dots \dots K \\ j = 1 \dots \dots K \end{array} \right\} i \neq j.$$

where \tilde{x}_j is the median of the j^{th} population. The test seems appropriate in these circumstances for determining differences in the distributions around a central ship, when the central ship takes different values of an independent variable. The hypothesis will always be that the domanges will vary with different values of the variable but the underlying domain shape should not change much. Thus Fig. VI.1 shows a typical series of patterns that could arise considering the distribution up to 2.5 nautical miles.

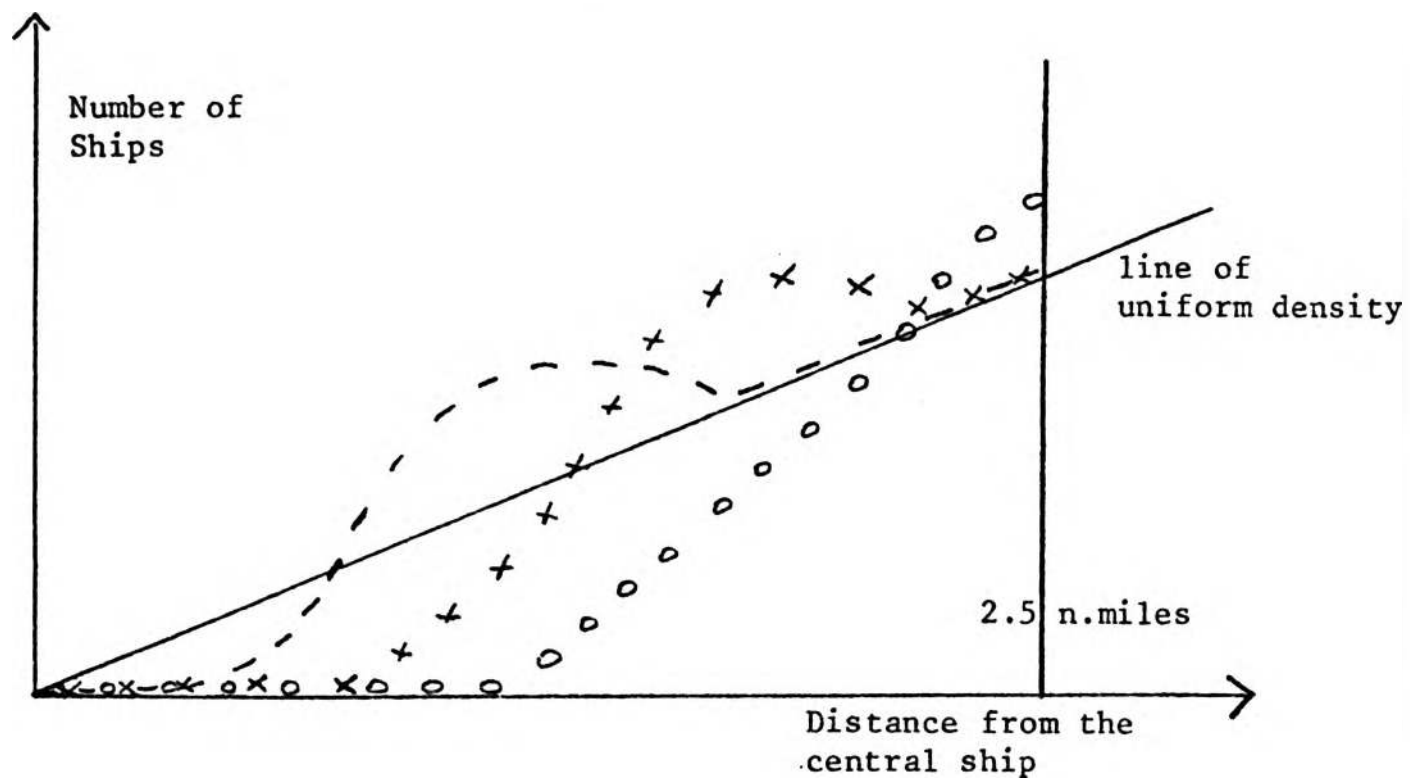

Key: Distribution of ships with central ship having different values of the independent variable being considered

- - - - Value 1
- x x x x Value 2
- o o o o Value 3

Fig. VI.1

Thus the median of each distribution should change if there is any fundamental shift in the displacement distribution under different values of the independent variable.

Example

The following example shows the calculations necessary for one particular set of circumstances. Table VI.1 shows the distributions of other ships from the central ship for each of the five categories of relative speed used. It refers to the simulator data: Sector 1. The calculated value of $H = 7.04$. Referring this to the χ^2 distribution with 4 degrees of freedom since there are 5 categories, it can be seen at the 5% level that the critical value is 9.49. The result is thus non-significant.

Correction of Ties

If there are a large number of observations with tied ranks it is possible to correct for this.

The correction factor is $1 - \frac{\Sigma T}{N^3 - N}$

where $N = \sum_{j=1}^K n_j$

$T = t^3 - t$ where t is the number of observations in a tie

ΣT denotes summation over all ties.

The corrected value of H , H' is given by

$H' = H \times \text{correction factor.}$

In this particular example the values of T are given in the final column of Table VI.1.

Thus the correction factor is $\frac{1}{.9961}$ and H' is 7.07 which is still non-significant. The effect of correction is always to increase H slightly but with the numbers involved in these particular analyses the effect is only of the order shown here. It was therefore ignored unless the result was only just non-significant but it never produced a varying result.

| Distance From Central Ships in .05 nm | Relative Speed in Knots | | | | | | Shared Ranks | Rank | Adjustment for Ranks Shared T |
|---------------------------------------|-------------------------|----------------|-----------------|-----------------|-------------|-------|--------------|-------|-------------------------------|
| | Under 5 | 5 but under 10 | 10 but under 15 | 15 but under 20 | 20 and over | Total | | | |
| 1 | 0 | 0 | 0 | 0 | 0 | 0 | 0 | 0 | 0 |
| 2 | 0 | 0 | 1 | 1 | 1 | 3 | 1-3 | 2 | 24 |
| 3 | 2 | 1 | 1 | 0 | 0 | 4 | 4-7 | 5.5 | 60 |
| 4 | 0 | 0 | 0 | 0 | 0 | 0 | 0 | 0 | 0 |
| 5 | 2 | 0 | 0 | 0 | 0 | 2 | 8-9 | 8.5 | 6 |
| 6 | 1 | 0 | 0 | 1 | 1 | 3 | 10-12 | 11 | 24 |
| 7 | 0 | 0 | 0 | 1 | 1 | 2 | 13-14 | 13.5 | 6 |
| 8 | 1 | 2 | 1 | 1 | 1 | 6 | 15-20 | 17.5 | 210 |
| 9 | 1 | 3 | 2 | 2 | 1 | 9 | 21-29 | 25 | 720 |
| 10 | 1 | 2 | 4 | 3 | 2 | 12 | 30-41 | 35.5 | 1716 |
| 11 | 0 | 1 | 1 | 5 | 2 | 9 | 42-50 | 46 | 720 |
| 12 | 2 | 4 | 5 | 3 | 2 | 16 | 51-66 | 58.5 | 4080 |
| 13 | 0 | 8 | 3 | 2 | 3 | 16 | 67-82 | 74.5 | 4080 |
| 14 | 1 | 3 | 5 | 7 | 0 | 16 | 83-98 | 90.5 | 4080 |
| 15 | 3 | 6 | 5 | 1 | 2 | 17 | 99-115 | 107 | 4896 |
| 16 | 3 | 2 | 4 | 5 | 3 | 17 | 116-132 | 124 | 4896 |
| 17 | 2 | 9 | 4 | 7 | 5 | 27 | 133-159 | 146 | 19656 |
| 18 | 3 | 4 | 9 | 5 | 7 | 28 | 160-187 | 173.5 | 21924 |
| 19 | 3 | 9 | 4 | 1 | 7 | 24 | 188-211 | 199.5 | 13800 |
| 20 | 5 | 12 | 6 | 2 | 5 | 30 | 212-241 | 226.5 | 26970 |
| 21 | 3 | 9 | 9 | 3 | 1 | 25 | 242-266 | 254 | 15600 |
| 22 | 3 | 12 | 1 | 7 | 4 | 27 | 267-293 | 280 | 19656 |
| 23 | 4 | 7 | 10 | 4 | 5 | 30 | 294-323 | 308.5 | 26970 |
| 24 | 1 | 12 | 8 | 1 | 2 | 24 | 324-347 | 335.5 | 13800 |
| 25 | 3 | 6 | 6 | 5 | 6 | 26 | 348-373 | 360.5 | 17750 |
| Total n _j | 44 | 112 | 89 | 67 | 61 | 373=N | | | ΣT=201644 |
| Sum of Ranks R _j | 7814 | 22740 | 17063 | 10751.5 | 11382.5 | | | | |

TABLE VI.1 Calculation of the Kruskal-Wallis one-way analysis of Variance for the Simulator Data: Relative Velocity: Sector 1.

APPENDIX VI, II ADDITIONAL GRAPHS ACCOMPANYING CHAPTER 6

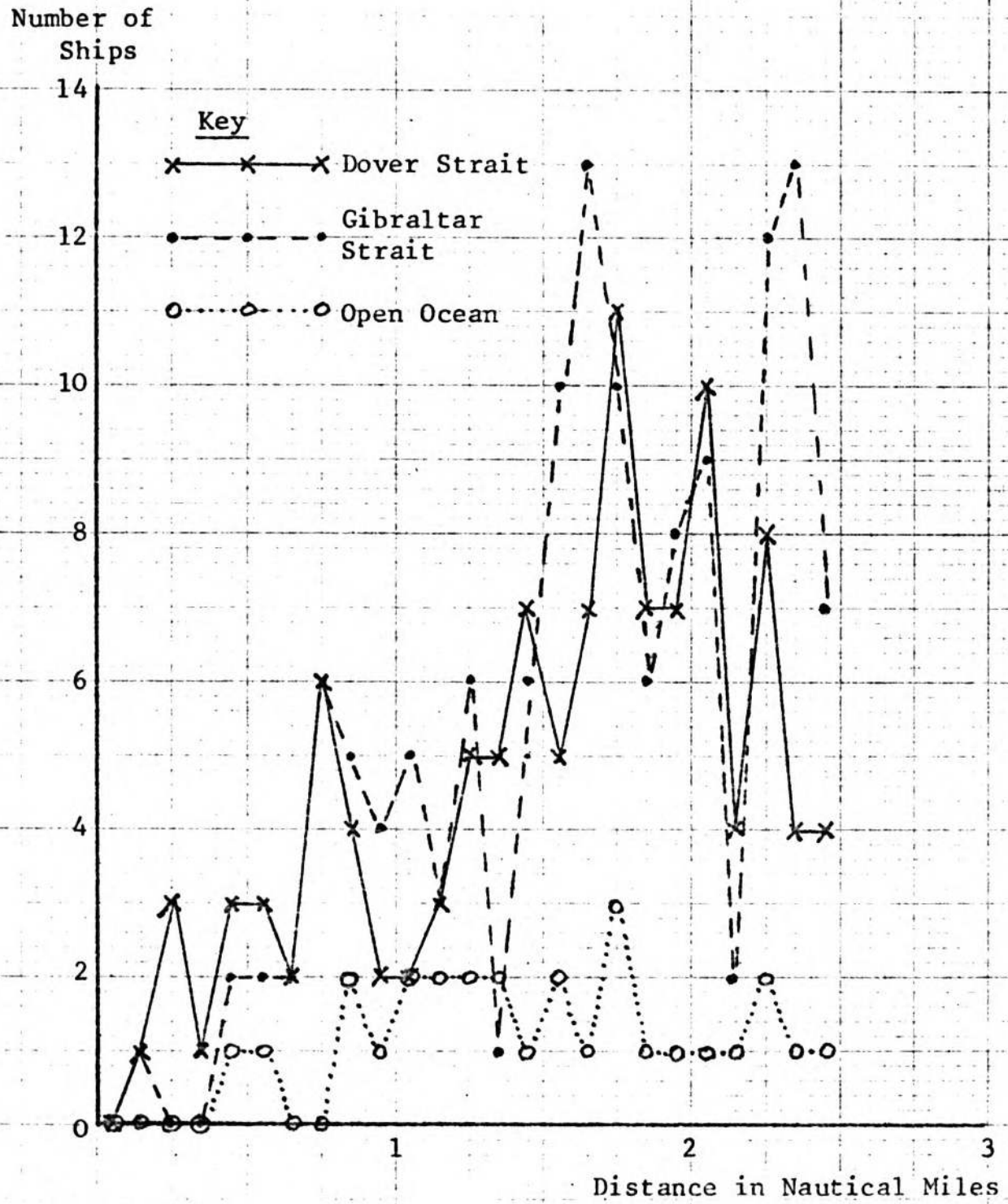

Notes (see p. 322)

- Dover Strait Domange = 0.8 n.miles
- Gibraltar Strait Domange = 1.5 n.miles
- Open Ocean Domange = 2.4 n.miles

FIG. VI. 2 Distribution of Ships Around a Central Ship by Area: Sector 1: Simulator Data

Number of
Ships

16

14

12

10

8

6

4

2

0

Key

X - X - X Dover Strait

• - • - • Gibraltar Strait

○ - ○ - ○ Open Ocean

1

2

3

Notes (see p. 322)

Dover Strait Domange = 0.1 n.miles

Gibraltar Strait Domange = 0.6 n.miles

Open Ocean Domange = 0.9 n.miles

FIG. VI.3 Distribution of Ships Around a Central Ship
by Area: Sector 3: Simulator Data

APPENDIX VI.III

THE DIFFERENCE BETWEEN THE DISTRIBUTIONS OF SHIPS AROUND
THE CENTRAL SHIP IN THE DOVER STRAIT AND SUNK AREAS

To compare the samples from each of the two areas the Mann-Whitney test was used. This test is based on the pair of hypotheses as follows:-

Null hypothesis H_0 : the two populations from which the two samples were drawn have identical distributions.

Alternative hypothesis H_1 : the two populations have different distributions.

Let n_1 be the number of values in the smaller sized sample and n_2 be the number of values in the larger sized sample.

The first step is to combine the two samples into one large sample and rank the values within the combined sample in ascending order.

If R_1 is the sum of ranks assigned to the sample with n_1 members, then the value of the test statistic U can be computed by the formula

$$U = n_1 n_2 + \frac{n_1(n_1 + 1)}{2} - R_1$$

For large samples, which was always the case in this investigation, it has been shown by Mann and Whitney (1947)⁽⁴¹⁾ that as $n_1 n_2$ increase in size, the sampling distribution of U rapidly approaches the normal distribution with mean $= \mu_u = \frac{n_1 n_2}{2}$

and variance $= \sigma_u^2 = \frac{n_1 n_2 (n_1 + n_2 + 1)}{12}$

Thus the appropriate test statistic becomes $z = \frac{U - \mu_u}{\sigma_u}$ which can be referred to a standard normal distribution.

For a 5% level of significance the critical values are ± 1.96 .

The test was performed separately for each of the three sectors.

Let n_{iDover} be the size of the sample of the distribution of ships in the i^{th} sector up to 2.5 n.miles in the Dover Strait exercises and let n_{iSunk} be the corresponding sample size for the Sunk surveys.

Thus:-

Sector 1

$$n_{1Dover} = 142 \quad n_{1Sunk} = 530$$

$$U = 41744$$

$$\mu_u = 37630$$

$$\sigma_u = 2054$$

$$z = \frac{40969 - 37630}{2054.5} = 2.00$$

Sector 2

$$n_{2Dover} = 104 \quad n_{2Sunk} = 538$$

$$U = 31539$$

$$\mu_u = 27976$$

$$\sigma_u = 1731.5$$

$$z = \frac{31539 - 27976}{1731.5} = 2.06$$

Sector 3

$$n_{3Dover} = 114 \quad n_{3Sunk} = 899$$

$$U = 49319$$

$$\mu_u = 44745$$

$$\sigma_u = 2590.7$$

$$z = \frac{49319 - 44745}{2590.7} = 1.77$$

APPENDIX VI.IV

COMPARISON OF THE MEAN RELATIVE SPEED FOR THE SHIPS IN THE SIMULATOR EXERCISES AND THE SHIPS IN THE SUNK SURVEY

Taking the distributions of relative speed as used in the analysis in Chapter 6, the following results were found

| | |
|--|--------------|
| Mean relative speed for ships in the simulator exercises | = 13.0 knots |
| Standard deviation | = 6.4 knots |
| Number in sample | = 3124 |
| Mean relative speed for ships in the Sunk surveys | = 11.2 knots |
| Standard deviation | = 6.0 knots |
| Number in sample | = 1853 |

It can be shown that the distributions of speed are approximately normal and the variances are nearly equal.

Thus to test the null hypothesis

H_0 : the mean relative speeds for the two situations are the same

against an alternative hypothesis

H_1 : the mean relative speeds for the two situations are different

with a level of significance

$\alpha = 5\%$

a parametric test based on the normal distribution can be used.

An estimate of the common variance is 6.2 knots.

$$\begin{aligned} \text{Thus test statistic } z &= \frac{12.95 - 11.21}{6.23 \sqrt{\frac{1}{3124} + \frac{1}{1853}}} \\ &= 9.89 \end{aligned}$$

Critical region is $-1.96 \leq z \leq +1.96$, thus the result is significant.

Taking now a level of significance $\alpha = .1\%$ the critical region becomes $-3.09 \leq z \leq +3.09$. Hence the result is very highly significant.

APPENDIX VI.V

COMPARISON OF THE DISTRIBUTION OF SHIPS BY SIZE IN THE DOVER STRAIT :
SIMULATOR EXERCISES AND A SURVEY OF SHIPS IN THE DOVER STRAIT

The survey used for comparison purposes is one of the National Physical Laboratory's surveys of shipping in the Dover Strait off Dungeness in 1971⁽¹⁰⁾. Distributions of ships by gross registered tonnage are given for areas at varying distances from the coast at Dungeness. Taking two examples (a) of ships at a distance between 5.6 n.miles and 12.8 n.miles approx. from the coast and (b) of ships at a distance of up to 3.1 n.miles and comparing them with (c) the distribution of own ships by gross registered tonnage in the Dover Strait exercises, the following picture emerges

| | Numbers of Ships | | |
|---|------------------|-----|-----|
| | (a) | (b) | (c) |
| Less than 10000 g.r.t. | 20 | 165 | 7 |
| 10000 g.r.t. but less than 20000 g.r.t. | 6 | 16 | 9 |
| 20000 g.r.t. and more | 4 | 7 | 6 |

(a) and (c) can be shown to be statistically not significant, but (b) and (c) are statistically very significant, using a χ^2 test.

Thus any conclusions using the simulator data subdivided by gross registered tonnage are likely to be suitable for the larger ships represented but unfortunately there will be no information on the smaller ships which in some areas form a considerable part of the traffic.

APPENDIX VI.VI

DISTRIBUTION OF SHIP SIZE BY AREA IN THE SIMULATOR DATA

| SIMULATOR DATA - ALL EXERCISES | | | | |
|--------------------------------|------------|---------------------|--------------|----------------|
| Gross Tonnage | Open Ocean | Strait of Gibraltar | Dover Strait | All Situations |
| Less than 10000 g.r.t. | 5 | 14 | 7 | 26 |
| 10000 g.r.t. | 116 | 11 | 4 | 131 |
| 11000 - 45000 g.r.t. | 2 | 21 | 7 | 30 |
| 50000 - 100000 g.r.t. | 3 | 9 | 4 | 16 |
| Not known | 0 | 2 | 2 | 4 |
| All ships | 126 | 57 | 24 | 207 |

Notes (see p. 322)

TABLE VI.2 Number of Own Ships in the Simulator Exercises Analysed by Area and By Gross Tonnage

Examination of Table VI.2 shows immediately that there is an over representation of ships of 10000 g.r.t. in the Open Ocean exercises. This was inevitable because this is the standard size of ship used in the opening exercises.

It is useful to compare roughly whether there is any difference between the other tonnage groups with regard to their distribution over the three areas. It was therefore decided to perform a χ^2 test of homogeneity over the modified distribution given below

| Gross Tonnage | Open Ocean | Strait of Gibraltar | Dover Strait | All Areas |
|------------------------|------------|---------------------|--------------|-----------|
| Less than 10000 g.r.t. | 5 | 14 | 7 | 26 |
| More than 10000 g.r.t. | 5 | 30 | 11 | 46 |
| All ships | 10 | 44 | 18 | 72 |

This distribution gives the number of ships by area in each of the two categories, less than 10000 g.r.t. and more than 10000 g.r.t. Thus the categories of not known and 10000 g.r.t. are ignored.

The χ^2 value calculated is only 1.24 which is non-significant, since the 5% critical value on 3 degrees of freedom is 7.81.

This analysis is obviously not very efficient but it does suggest that the main feature is the 10000 g.r.t. group. For the other groups the areas are represented in the same proportions so should have the same effects. However, there still may be interaction between area and size of ship because of the nature of the area.

APPENDIX VI.VII

JOINT-DISTRIBUTION OF SHIP SIZE IN GROSS TONNAGE AND MAXIMUM SPEED IN THE SIMULATOR DATA

| SIMULATOR DATA - ALL EXERCISES | | | | | |
|--|-------|----|-----|-------------|-----------|
| Gross Tonnage \ maximum speed in knots | 10-14 | 15 | 16 | 17 and Over | All Ships |
| Less than 10000 g.r.t. | 14 | 3 | 2 | 7 | 26 |
| 10000 g.r.t. | 36 | 1 | 86 | 8 | 131 |
| 10000 - 45000 g.r.t. | 0 | 5 | 7 | 18 | 30 |
| 50000 - 100000 g.r.t. | 0 | 2 | 12 | 2 | 16 |
| All ships | 50 | 11 | 107 | 35 | 203 |

Notes (see p.322)

TABLE VI.3 Number of Own Ships in the Simulator Exercises by Gross Tonnage and by Maximum Speed in Knots

Table VI.3 gives the details on maximum speed and gross-registered tonnage for all the own ships in the simulator data for which both details were recorded. There were in fact only four ships which were not known.

It was decided to investigate the nature of the statistical relationship between the two quantities and hence the Spearman rank correlation coefficient⁽⁴²⁾ was calculated. A rank correlation coefficient was chosen in preference to a parametric product-moment correlation coefficient because the groupings were fairly coarse and hence numerical values for the midpoints of each class seemed hardly justified. It also had the advantage of speed of calculation.

The value calculated was 0.48 which can be shown to be significantly different from 0 at a 5% level of significance. It is thus reasonable to conclude that there is a direct relationship between the size of ship and its maximum speed for the own ships used in the simulator exercises. A value of 0.48 is however not very large so the association cannot be assumed to be very strong.

APPENDIX VI.VIII

DISTRIBUTION OF LENGTH OF SEA EXPERIENCE OF THE NAVIGATOR
OF THE CENTRAL SHIP BY AREA IN THE SIMULATOR DATA

| SIMULATOR DATA - ALL EXERCISES | | | | |
|--------------------------------|------------|---------------------|--------------|----------------|
| Length of Sea-Experience | Open Ocean | Strait of Gibraltar | Dover Strait | All Situations |
| 6 - 8 years | 17 | 7 | 6 | 30 |
| 9 - 11 years | 35 | 16 | 4 | 55 |
| 12 - 14 years | 9 | 2 | 1 | 12 |
| 15 - 19 years | 13 | 5 | 4 | 22 |
| 20 - 26 years | 18 | 9 | 2 | 29 |
| 27 - 41 years | 22 | 16 | 7 | 45 |
| Not known | 12 | 2 | 0 | 14 |
| All ships | 126 | 57 | 24 | 207 |

Notes (see p.322)

TABLE VI.4 Number of Own Ships in the Simulator Exercises by Area and by Length of Sea-Experience of the Navigator

Table VI.4 shows the number of own ships by area and by length of sea experience of the navigator. Omitting the not known category and considering the rest of the table as a contingency table, a χ^2 value of 8.71 is calculated. With 10 degrees of freedom the critical value of χ^2 at the 5% level is 18.31. Thus it may be concluded that there is no significant difference between the representation of experience in each of the different areas.

APPENDIX VI.IX

COMPARISON OF THE DISTRIBUTIONS BY SECTOR OF ALL OTHER SHIPS WITH

(a) FISHING BOATS AS CENTRE SHIPS AND

(b) ALL OTHER SHIPS EXCEPT FISHING BOATS AS CENTRE SHIPS:

SUNK DATA

The test used will be the Mann-Whitney U test, a non-parametric test for determining whether two samples have been drawn from the same population, described on page 294.

Let $\bar{x}_{i \text{ sunk}}$ be the mean of the observed distribution of the distance of ships from a central ship considered up to 2.5 n.miles in the i^{th} sector for the Sunk survey data. Let $n_{i \text{ sunk}}$ be the number of points in the observed distribution as defined above. Let $\mu_{i \text{ sunk}}$ be the mean of the corresponding theoretical distribution. Let $\bar{x}_{i \text{ Fish}}$, $n_{i \text{ Fish}}$ and $\mu_{i \text{ Fish}}$ be the corresponding quantities for the distributions of ships up to 2.5 n.miles around fishing boats as central ship.

Thus:-

Sector 1

$$\begin{array}{ll} \bar{x}_1 \text{ Sunk} = 1.72 & \bar{x}_1 \text{ Fish} = 1.58 \\ n_1 \text{ Sunk} = 530 & n_1 \text{ Fish} = 104 \end{array}$$

Sector 2

$$\begin{array}{ll} \bar{x}_2 \text{ Sunk} = 1.65 & \bar{x}_2 \text{ Fish} = 1.66 \\ n_2 \text{ Sunk} = 538 & n_2 \text{ Fish} = 97 \end{array}$$

Sector 3

$$\begin{array}{ll} \bar{x}_3 \text{ Sunk} = 1.65 & \bar{x}_3 \text{ Fish} = 1.47 \\ n_3 \text{ Sunk} = 785 & n_3 \text{ Fish} = 89 \end{array}$$

The sample means are not involved in the determination of significant differences between the distributions under the two conditions in each of the sectors but are shown here for comparison purposes. The inference which is used again is that if the Mann-Whitney test shows the distributions to be significantly different then their means will be significantly different and so will the domanges.

The results of the tests are given below

Sector 1

$$H_0 : \mu_1 \text{ Sunk} = \mu_1 \text{ Fish}$$

$$H_1 : \mu_1 \text{ Sunk} \neq \mu_1 \text{ Fish}$$

$$\alpha = 5\%$$

$$\text{Test statistic } z = 2.01$$

Sector 2

$$H_0 : \mu_2 \text{ Sunk} = \mu_2 \text{ Fish}$$

$$H_1 : \mu_2 \text{ Sunk} \neq \mu_2 \text{ Fish}$$

$$\alpha = 5\%$$

$$\text{Test statistic } z = -0.45$$

Sector 3

$$H_0 : \mu_3 \text{ Sunk} = \mu_3 \text{ Fish}$$

$$H_1 : \mu_3 \text{ Sunk} \neq \mu_3 \text{ Fish}$$

$$\alpha = 5\%$$

$$\text{Test statistic } z = 2.28$$

Acceptance region in each case $-1.96 \leq z \leq +1.96$

Thus Sector 1 significant
 Sector 2 not significant
 Sector 3 significant

COMPARISON OF THE DISTRIBUTIONS BY SECTOR WITH ALL OTHER SHIPS

EXCEPT FISHING BOATS AS CENTRE SHIPS OF (a) FISHING BOATS AND

(b) ALL OTHER SHIPS EXCEPT FISHING BOATS: SUNK DATA

A similar set of tests as used in the previous section are used here. Let \bar{x}_{is} , n_{is} , μ_{is} be the relevant quantities for the distributions of ships excluding fishing vessels up to 2.5 n.miles around the central ship. Let \bar{x}_{iF} , n_{iF} , μ_{iF} be the corresponding quantities for the distributions of fishing vessels up to 2.5 n.miles around the central ship.

Then:-

Sector 1

$$\bar{x}_{1s} = 1.73 \quad \bar{x}_{1F} = 1.61$$

$$n_{1s} = 501 \quad n_{1F} = 29$$

Sector 2

$$\bar{x}_{2s} = 1.65 \quad \bar{x}_{2F} = 1.61$$

$$n_{2s} = 503 \quad n_{2F} = 33$$

Sector 3

$$\bar{x}_{3s} = 1.64 \quad \bar{x}_{3F} = 1.73$$

$$n_{3s} = 712 \quad n_{3F} = 73$$

The results of the tests are as follows:

Sector 1

$$H_0 : \mu_{1s} = \mu_{1F}$$

$$H_1 : \mu_{1s} \neq \mu_{1F}$$

$$\alpha = 5\%$$

$$\text{Test statistic } z = 0.76$$

Sector 2

$$H_0 : \mu_{2s} = \mu_{2F}$$

$$H_1 : \mu_{2s} \neq \mu_{2F}$$

$$\alpha = 5\%$$

$$\text{Test statistic } z = 0.48$$

Sector 3

$$H_0 : \mu_{3s} = \mu_{3F}$$

$$H_1 : \mu_{3s} \neq \mu_{3F}$$

$$\alpha = 5\%$$

$$\text{Test statistic } z = -1.07$$

Acceptance region in each case $-1.96 \leq z \leq 1.96$

Thus: Sector 1 not significant
Sector 2 not significant
Sector 3 not significant

APPENDIX VI.X

COMPARISON OF THE DISTRIBUTION OF BUOYS WHEN (a) NO EXCLUSIONS
ARE MADE FOR THE CENTRAL SHIP AND (b) ALL SHIPS NEAR THE PILOT,
IN THE CHANNEL OR FISHING ARE EXCLUDED AS THE CENTRAL SHIP

If all sectors are considered together, then the numbers of buoy-points within increasing mile ranges of the central ship, when the central ship falls into each of the two categories defined above are as follows:

| No. of Buoy-points | Central Ship with | |
|-------------------------------|-------------------|----------------|
| | (a) No exclusions | (b) Exclusions |
| Within 1 n.mile | 197 | 22 |
| 1 n.mile but under 2 n.miles | 370 | 94 |
| 2 n.miles but under 3 n.miles | 453 | 133 |
| 3 n.miles but under 4 n.miles | 472 | 134 |
| 4 n.miles but under 5 n.miles | 514 | 135 |
| Total | 2006 | 518 |

Since distribution (b) is a subset of distribution (a) it would be more sensible to compare distribution (b) with distribution (a) - distribution (b). Thus a new table can be drawn up

| No of Buoy-points | (a)-(b) Ships near the pilot boat, the pilot boat, fishing boats and ships in the channel or at the edge of the radar screen | (b) All Other Ships |
|-------------------------------|--|------------------------------|
| | Within 1 n.mile | 175 |
| 1 n.mile but under 2 n.miles | 276 | 94 |
| 2 n.miles but under 3 n.miles | 320 | 133 |
| 3 n.miles but under 4 n.miles | 338 | 134 |
| 4 n.miles but under 5 n.miles | 379 | 135 |
| Total | 1488 | 518 |

Performing a χ^2 test of homogeneity a value of $\chi^2 = 26.74$ is obtained. Since the appropriate critical value at a .1% level of significance is 18.47, this result is very highly significant. The largest differences arise in the number of buoy-points within 1 n.mile of the central ships.

APPENDIX VII

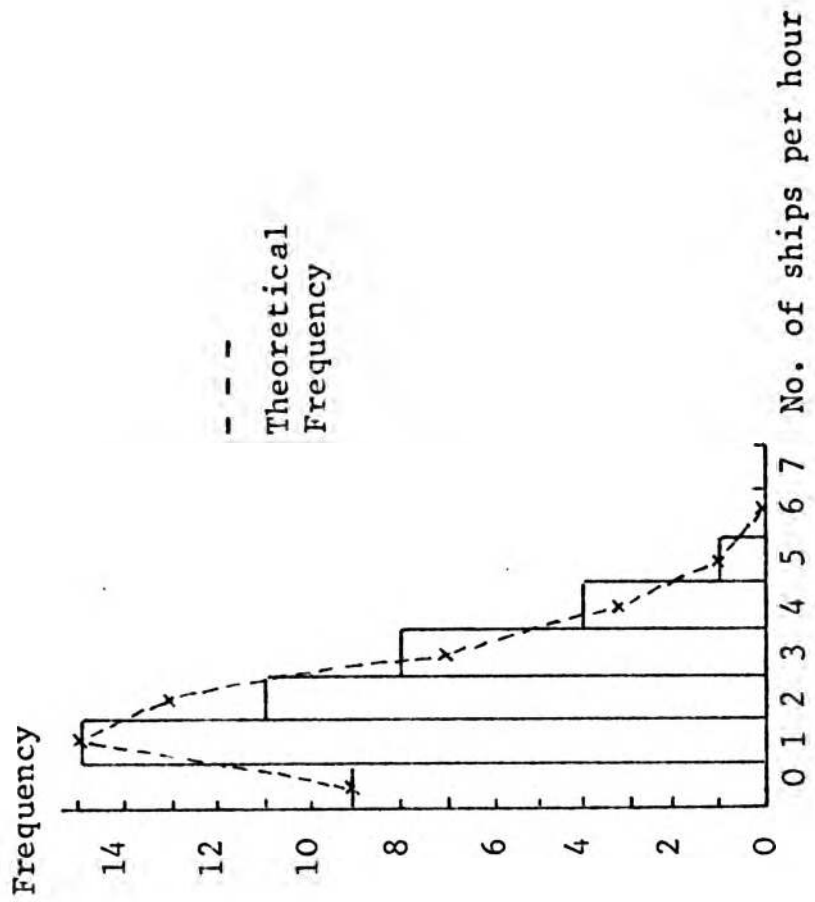

Goodwin Sands to South Falls Buoy

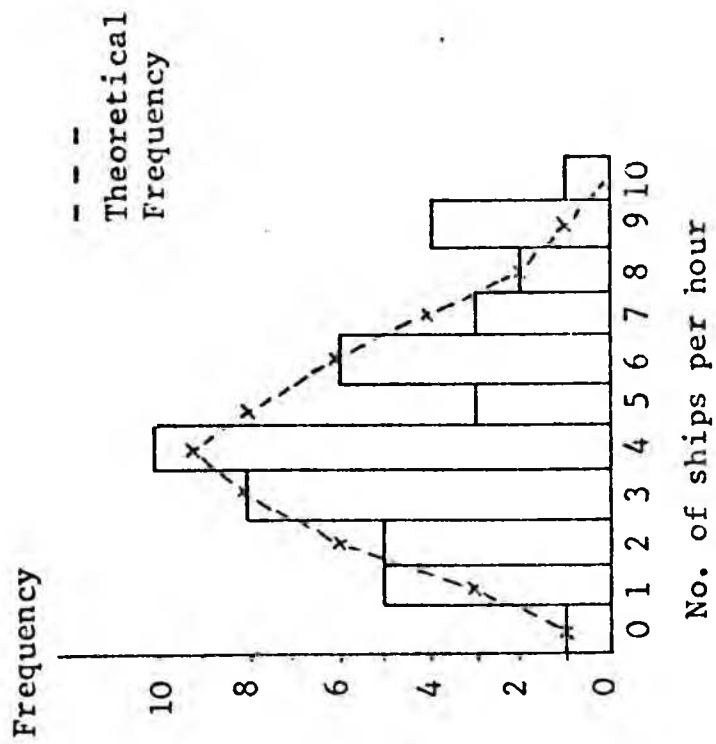

Main SW lane

FIG. VII.1 Fitted Poisson Distributions for the Number of Ships per hour passing Through Zones of the Dover Strait from 12.00 hrs. G.M.T. 27th April 1971 - 12.00 hrs. G.M.T. 29th April 1971.

APPENDIX VIII

Notes on the Computer Program Used

1. Basic program for the simulator data to sort out bearings and distances by separate exercises and by all exercises combined.

| | |
|---|----|
| MASTER | 1 |
| REAL NO | 2 |
| DIMENSION N(50,3),V(10,15),CO(10,15),NO(25,15),D(25,15), B(25,15), E (3),C(3),S(3),NN(50,3,20) | 3 |
| DO 11 I=1,50 | 4 |
| DO 11 J=1,3 | 5 |
| 11 N(I,J)=0 | 6 |
| DO 12 I=1,50 | 7 |
| DO 12 J=1,3 | 8 |
| DO 12 K=1,20 | 9 |
| 12 NN(I,J,K)=0 | 10 |
| DO 50 M=1,41 | 11 |
| READ(1,998) IC,IE,ITIME,IO,IT,IL | 12 |
| 998 FORMAT(6IO) | 13 |
| IN=IO+IT | 14 |
| READ(1,997)((V(I,J),CO(I,J),J=1,ITIME),I=1,IN) | 15 |
| 997 FORMAT(24OFO.O) | 16 |
| READ(1,999)(E(I),C(I),S(I),I=1,IO) | 17 |
| 999 FORMAT(9FO.O) | 18 |
| READ(1,994)((NO(L,J),D(L,J),B(L,J),J=1,ITIME),L=1,IL) | 19 |
| 994 FORMAT(72OFO.O) | 20 |
| WRITE(6,978) IC,IE,ITIME,IO,IL | 21 |
| 978 FORMAT(1H ,615) | 22 |
| 13 DO 3 L=1,IL | 23 |
| DO 3 K=1,ITIME | 24 |
| IF(D(L,K).GT.5.)GO TO 3 | 25 |
| D(L,K)=D(L,K)*10. | 26 |
| I=INT(D(L,K)) | 27 |
| 5 IF(B(L,K).GE.0..AND.B(L,K).LT.112.5)GO TO 6 | 28 |
| IF(B(L,K).GE.112.5.AND.B(L,K).LT.247.5)GO TO 8 | 29 |
| IF(B(L,K).GE.247.5.AND.B(L,K).LT.360.)GO TO 7 | 30 |
| IF(B(L,K).EQ.360.)GO TO 6 | 31 |
| WRITE(6,975) NO(L,K),D(L,K),B(L,K) | 32 |
| 975 FORMAT(1H ,F12.0,2F4.0) | 33 |
| GO TO 3 | 34 |
| 7 NN(I,2,IE)=NN(I,2,IE)+1 | 35 |
| GO TO 3 | 36 |
| 6 NN(I,1,IE)=NN(I,1,IE)+1 | 37 |
| GO TO 3 | 38 |
| 8 NN(I,3,IE)=NN(I,3,IE)+1 | 39 |
| 3 CONTINUE | 40 |
| 50 CONTINUE | 41 |
| DO 20 IE=1,20 | 42 |
| DO 20 J=1,3 | 43 |
| WRITE(6,989) IE,J | 44 |
| 989 FORMAT(1H ,8HEXERCISE,2X,I2,2X,6HSECTOR,2X,I1) | 45 |
| WRITE(6,988) (NN(I,J,IE),I=1,50) | 46 |
| 988 FORMAT(25I3/25I3) | 47 |
| 20 CONTINUE | 48 |
| DO 30 I=1,50 | 49 |

```

DO 30 J=1,3 50
DO 30 IE=1,20 51
30 N(I,J)=NN(I,J,IE)+N(I,J) 52
DO 31 J=1,3 53
WRITE(6,987) J 54
987 FORMAT(1H ,12HTOTAL SECTOR,2X,I1) 55
31 WRITE(6,988)(N(I,J),I=1,50) 56
STOP 57
END 58

```

2. Modification to basic program for the simular data omitting the 1st 2 time points.

Change statement 24 to read

```
24 DO 3 K=3, ITIME
```

3. Modified Program for the Sunk survey data to calculate and sort out bearings and distances

```

MASTER 1
C SUNK SURVEY DATA 2
C E IS NUMBER,T IS TIME.P IS POSITION,BL IS LENGTH BP, 3
C C IS GROSS TONNAGE 4
M M IS NUMBER OF OBSERVATIONS 5
DIMENSION N(50,3),F(50),DE(50,3),E(300),XA(300),YA(300),XB(300),YB(300), 6
T(300),C(300),P(300),BL(300),NN(50,3,10),SNE(50,3),SNV(50,3),SNW
(50,3),NCUM(50,3),SNWCUM(50,3),TOT(50,3),SLO(50,3),ISIGN(50,3)
READ(1,997) ISURVEY 7
997 FORMAT(I1) 8
READ(1,990) IHOURS 9
990 FORMAT(I2) 10
WRITE(6,996) ISURVEY, IHOURS 11
996 FORMAT(2I2) 12
DO 2 J=1,3 13
DO 2 I=1,50 14
2 N(I,J)=0 15
DO 13 KK=1, IHOURS 16
READ(1,999)M 17
999 FORMAT(I5) 18
DO 1 I=1,M 19
1 READ(1,998)E(I),XA(I),XB(I),YB(I),T(I),P(I),BL(I),C(I) 20
998 FORMAT(9F0.0) 21
DO 3 I=1,M 22
IF(YA(I)*YA(I)+XA(I)*XA(I).GT.9.) GO TO3 23
IF(C(I).EQ.9..OR.C(I).EQ.8.) GO TO 3 24
IF(P(I).NE.0.) GO TO 3 25
DO 9 J=1,M 26
IF(E(I).EQ.E(J).OR.T(I).NE.T(J)) GO TO 9 27
XAR=XA(J)-XA(I) 28
YAR=YA(J)-YA(I) 29
XAC=XB(I)-XA(I) 30
YAC=YB(I)-YA(I) 31
YARV=YB(J)-YA(J)-YB(I)+YA(I) 32
XARV=XB(J)-XA(J)-XB(I)+XA(I) 33
CALL RELVELSUNK(R,B,XAR,YAR) 34
IF(R.GE.50.) GO TO 9 35

```

| | |
|--|----|
| CALL RELVELSUNK(RR.RC,XAC,YAC) | 36 |
| B=RC-B | 37 |
| IF(B.LT.O.)B=360.+B | 38 |
| CALL COUNT(F,FA,N,R,B) | 39 |
| 9 CONTINUE | 40 |
| 3 CONTINUE | 41 |
| 13 CONTINUE | 42 |
| WRITE(6,991)((N(I,J),I=1,50),J=1,3) | 43 |
| 991 FORMAT(25I3/25I3) | 44 |
| CALL SMOOTH(SNE,SNV,SNW,N) | 45 |
| CALL CUMULATE(N,NCUM,SNW,SNWCUM) | 46 |
| CALL DOMAIN(SNW,SNWCUM,TOT,SLO,ISIGN,NCUM) | 47 |
| STOP | 48 |
| END | 49 |
| | |
| SUBROUTINE RELVELSUNK(R,B,X,Y) | 50 |
| R=(SQRT(X**2+Y**2))*10. | 51 |
| IF(X.NE.O.)GO TO 2 | 52 |
| IF(Y)3,4,5 | 53 |
| 3 B=270 | 54 |
| GO TO 6 | 55 |
| 4 B=90. | 56 |
| GO TO 6 | 57 |
| 5 B=90. | 58 |
| GO TO 6 | 59 |
| 2 B=(ATAN(Y/X))*57.3 | 60 |
| IF(X.LE.O.)B=180.+B | 61 |
| IF(X.GT.O..AND.Y.LT.O.)B=360.+B | 62 |
| 6 RETURN | 63 |
| END | 64 |
| | |
| SUBROUTINE COUNT(F,FA,N,R,B) | 65 |
| C COUNTS INTO SECTORS 5 MILES BY TENTHS | 66 |
| DIMENSION N(50,3),F(50) | 67 |
| I=INT(R) | 68 |
| I=I+1 | 69 |
| 3 IF(B.GE.O..AND.B.LT.112.5) GO TO 5 | 70 |
| IF(B.GE.112.5.AND.B.LT.247.5) GO TO 7 | 71 |
| IF(B.GE.247.5.AND.B.LT.360.) GO TO 6 | 72 |
| IF(B.EQ.360.) GO TO 5 | 73 |
| 5 N(I,1)=N(I,1)+1 | 74 |
| GO TO 4 | 75 |
| 6 N(I,2)=N(I,2)+1 | 76 |
| GO TO 4 | 77 |
| 7 N(I,3)=N(I,3)+1 | 78 |
| 4 RETURN | 79 |
| END | 80 |

N.B.(1) For the relevance of statements 45-47 see note 4 below.

(2) The basic program for the Sunk survey data with no exclusions as central ship omits statements 23,24,25.

4. Subroutines to smooth data, to produce cumulative totals and to calculate the damage by the method of displaced numbers. The same subroutines can be applied to either type of data.

| | |
|---|-----|
| SUBROUTINE SMOOTH(SNE,SNV,SNW,N) | 81 |
| DIMENSION SNE(50,3),SNV(50,3),SNW(50,3),N(50,3) | 82 |
| DO 1 J=1,3 | 83 |
| SNW(1,J)=0. | 84 |
| SNE(2,J)=0.4*N(2,J) | 85 |
| SNV(1,J)=0. | 86 |
| SNW(1,J)=0. | 87 |
| SNV(2,J)=0.25*N(1,J)+0.5*N(2,J)+0.25*N(3,J) | 88 |
| 1 SNW(2,J)=(N(1,J)+N(2,J)+N(3,J))/3. | 89 |
| DO 2 J=1,3 | 90 |
| DO 2 I=3,48 | 91 |
| SNE(I,J)=0.4*N(I,J)+0.6*SNE(I-1,J) | 92 |
| SNV(I,J)=0.1*N(I-2,J)+0.2*N(I-1,J)+0.4*N(I,J)+0.2 | 93 |
| *N(I+1,J)+0.1*N(I+2,J) | 94 |
| 2 SNW(I,J)=(N(I-1,J)+N(I,J)+N(I+1,J))/3 | 95 |
| DO 4 J=1,3 | 96 |
| WRITE(6,3) J | 97 |
| 3 FORMAT(1H ,20HEXPOENTIAL SECTOR,2X,I1) | 98 |
| 4 WRITE(6,5)(SNE(I,J),I=1,48) | 99 |
| 5 FORMAT(1H ,10F7.3/10F7.3/10F7.3/10F7.3/8F7.3 | 100 |
| DO 6 J=1,3 | 101 |
| WRITE(6,7) J | 102 |
| 7 FORMAT(1H ,24HWEIGHTED VARIABLE SECTOR,2X,I1) | 103 |
| 6 WRITE(6,5)(SNV(I,J),I=1,48) | 104 |
| DO 8 J=1,3 | 105 |
| WRITE(6,9) J | 106 |
| 9 FORMAT(1H ,23HWEIGHTED EQUAL SECTOR,2X,I1) | 107 |
| 8 WRITE(6,5)(SNW(I,J),I=1,48) | 108 |
| RETURN | 109 |
| END | 110 |
| | |
| SUBROUTINE CUMULATE(N,NCUM,SNW,SNWCUM) | 111 |
| DIMENSION N(50,3),NCUM(50,3),SNW(50,3),SNWCUM(50,3) | 112 |
| DO 1 J=1,3 | 113 |
| SNW(49,J)=0. | 114 |
| SNW(50,J)=0. | 115 |
| NCUM(1,J)=N(1,J) | 116 |
| SNWCUM(1,J)=SNW(1,J) | 117 |
| DO 1 I=2,50 | 118 |
| SNWCUM(I,J)=SNW(I,J)+SNWCUM(I-1,J) | 119 |
| 1 NOUM(I,J)=N(I,J)+NCUM(I-1,J) | 120 |
| DO 3 J=1,3 | 121 |
| WRITE(6,2) J | 122 |
| 2 FORMAT(1H ,17HCUMULATIVE SECTOR,2X,I1) | 123 |
| 3 WRITE(6,4)(NCUM(I,J),I=1,50) | 124 |
| 4 FORMAT(25I3/25I3) | 125 |
| DO 5 J=1,3 | 126 |
| WRITE(6,6) J | 127 |
| 6 FORMAT(1H ,26HSMOOTHED CUMULATIVE SECTOR,2X,I1) | 128 |
| 5 WRITE(6,7)(SNWCUM(I,J),I=1,50) | 129 |
| 7 FORMAT(1H ,10F7.2) | 130 |
| RETURN | 131 |
| END | 132 |

```

SUBROUTINE DOMAIN(SNW,SNWCUM,TOT,SLO,ISIGN,NCUM)      133
DIMENSION SNW(50,3),SNWCUM(50,3),TOT(50,3),SLO(50,3), 134
ISIGN(50,3),NCUM(50,30)
DO 12 J=1,3                                          135
WRITE(6,5) J                                         136
5 FORMAT(1H ,6HSECTOR,2X,I1)                         137
DO 1 I=1,50                                          138
TOT(I,J)=(SNW(I,J)*I*I)/(2*I-1)                     139
IF(TOT(I,J).LT.SNWCUM(I,J)) GO TO 2                 140
IF(TOT(I,J).GT.SNWCUM(I,J)) GO TO 3                 141
ISIGN(I,J)=2                                         142
GO TO 4                                               143
2 ISIGN(I,J)=0                                       144
GO TO 4                                               145
3 ISIGN(I,J)=1                                       146
4 SLO(I,J)=(NCUM(I,J)*100.)/(I*I)                    147
1 CONTINUE                                           148
WRITE(6,6)                                           149
6 FORMAT(1H ,5HTOTAL)                                150
WRITE(6,7)(TOT(I,J),I=1,50)                          151
7 FORMAT(1H ,10F7.2)                                  152
WRITE(6,8)                                           153
8 FORMAT(1H ,10HCUMULATIVE)                           154
WRITE(6,7)(SNWCUM(I,J),I=1,50)                        155
WRITE(6,9)                                           156
9 FORMAT(1H ,10HDIFFERENCE)                           157
WRITE(6,10)(ISIGN(I,J),I=1,50)                        158
10 FORMAT(1H ,10I3)                                   159
WRITE(6,11)                                           160
11 FORMAT(1H ,5HSLOPE)                                161
WRITE(6,7)(SLO(I,J),I=1,50)                          162
12 CONTINUE                                           163
RETURN                                               164
END                                                  165

```

5. Simulator data: program to calculate relative velocities and produce the distributions by different ranges of relative velocity

```

MASTER                                             1
REAL NO                                           2
DIMENSION N(50,3),V(10,15),CO(10,15),COR(10,15),HV(10,15), 3
VV(10,15),X(15),Y(15),RV(25,15),RCOR(25,15),NO(25,15),D(
25,15),B(25,15),E(3),RE(25)C(3),RC(25),S
(3),RS(25),NN(50,3,20),SNE(50,3),SNV(50,3),SNW(50,3),NCUM
(50,3),SNWCUM(50,3),TOT(50,3),SLO(50,3),ISIGN(50,3)
DO 11 I=1,50                                          4
DO 11 J=1,3                                          5
11 N(I,J)=0                                           6
DO 12 I=1,50                                          7
DO 12 J=1,3                                          8
DO 12 K=1,20                                          9
12 NN(I,J,K)=0                                       10
DO 50 M=1,41                                         11
READ(1,998) IC,IE,ITIME,IO,IT,IL                    12
998 FORMAT(6I0)                                       13
IN=IO+IT                                             14
READ(1,997)((V(I,J),CO(I,J),J=1,ITIME),I=1,IN)     15
997 FORMAT(240FO.0)                                  16

```



```

          READ(1,999)(E(I),C(I),S(I),I=1,IO)
999  FORMAT(9FO.0)
          READ(1,994)((NO(L,J),D(L,J),B(L,J),J=1,ITIME),L=1,IL)
994  FORMAT(72OFO.0)
          WRITE(6,978) IC,IE,ITIME,IO,IL
978  FORMAT(1H,615)
          IF(IE.LT.7) GO TO 14
          DO 2 I=1,IN
          DO 2 J=1,ITIME
          COR(I,J)=CO(I,J)*.0175
          HV(I,J)=V(I,J)*COS(COR(I,J))
          2 VV(I,J)=V(I,J)*SIN(COR(I,J))
          DO 4 J=1,ITIME
          X(J)=HV(2,J)-HV(1,J)
          4 Y(J)=VV(2,J)-VV(1,J)
          I=1
          CALL RELVEL(RV,RCOR,I,ITIME,X,Y)
          DO 25 J=1,ITIME
25  RV(2,J)=RV(1,J)
          DO 21 J=1,ITIME
          X(J)=HV(3,J)-HV(1,J)
21  Y(J)=VV(3,J)-VV(1,J)
          I=3
          CALL RELVEL(RV,RCOR,I,ITIME,X,Y)
          DO 22 J=1,ITIME
22  RV(4,J)=RV(3,J)
          I=5
          DO 23 J=1,ITIME
          X(J)=HV(3,J)-HV(2,J)
23  Y(J)=VV(3,J)-VV(2,J)
          CALL RELVEL(RV,RCOR,I,ITIME,X,Y)
          DO 24 J=1,ITIME
24  RV(6,J)=RV(5,J)
14  DO 10 K=1,IO
          IP=IO+1
          DO 10 I=IP,IN
          L=I-IO+6+(K-1)*IT
          IF(IE.LT.7) L=L-6
          DO 15 J=1,ITIME
          X(J)=HV(I,J)-HV(K,J)
15  Y(J)=VV(I,J)-VV(K,J);
          CALL RELVEL(RV,RCOR,L,ITIME,X,Y)
10  CONTINUE
13  DO 3 L=1,IL
          DO 3 K=3,ITIME
          IV=INT(RV(L,K)/5)+1
          IF(IF.GE.6) IV=6
          IF(D(L,K).GT.5.)GO TO 3
          D(L,K)=D(L,K)*10.
          I=INT(D(L,K))
          IF(B(L,K).GE.0..AND.B(L,K).LT.112.5)GO TO 6
          IF(B(L,K).GE.112.5.AND.B(L,K).LT.247.5)GO TO 8
          IF(B(L,K).GE.247.5.AND.B(L,K).LT.360.)GO TO 7
          IF(B(L,K).EQ.360.)GO TO 6
          WRITE(6,975) NO(L,K),D(L,K),B(L,K)
975  FORMAT(1H,F12.0,2F4.0)
          GO TO 3
          6 NN(I,1,IV)=NN(I,1,IV)+1
          GO TO 3
```

```
7 NN(I,2,IV)=NN(I,2,IV)+1 76
  GO TO 3 77
8 NN(I,3,IV)=NN(I,3,IV)+1 78
3 CONTINUE 79
50 CONTINUE 80
  DO 20 IV=1,6 81
  DO 20 J=1,3 82
  WRITE(6,989)IV,J 83
989 FORMAT(1H ,17HRELATIVE VELOCITY,2X,I2,2X,6HSECTOR,2X,I1) 84
  WRITE(6,988)(NN(I,J,IV),I=1,50) 85
988 FORMAT(25I3/25I3) 86
20 CONTINUE 87
  DO 30 I=1,50 88
  DO 30 J=1,3 89
  DO 30 IV=1,6 90
30 N(I,J)=NN(I,J,IV)+N(I,J) 91
  DO 31 J=1,3 92
  WRITE(6,987) J 93
987 FORMAT(1H ,12HTOTAL SECTOR,2X,I1) 94
  WRITE(6,940)(N(I,J),I=1,50) 95
940 FORMAT(25I3/25I3) 96
31 CONTINUE 97
  WRITE(6,969) 98
969 FORMAT(1H ,22HALL EXERCISES SMOOTHED) 99
  CALL SMOOTH(SNE,SNV,SNW,N) 100
  CALL CUMULATE(N,NCUM,SNW,SNWCUM) 101
  DO 40 IV=1,6 102
  DO 41 I=1,50 103
  DO 41 J=1,3 104
41 N(I,J)=NN(I,J,IV) 105
  WRITE(6,950) IV 106
950 FORMAT(1H ,5HCLASS,2X,I2 107
  CALL SMOOTH(SNE,SNV,SNW,N) 108
  CALL CUMULATE(N,NCUM,SNW,SNWCUM) 109
  CALL DOMAIN(SNW,SNWCUM,TOT,SLO,ISIGN,NCUM) 110
40 CONTINUE 111
  STOP 112
  END 113

SUBROUTINE RELVEL(RV,RCOR,I,ITIME,X,Y) 114
DIMENSION RV(25,15),RCOR(25,15) 115
DIMENSION X(15),Y(15) 116
DO 6 J=1,ITIME 117
RV(I,J)=(SQRT(X(J)**2+Y(J)**2)) 118
IF(X(J).NE.0.) GO TO 2 119
IF(Y(J))3,4,5 120
3 RCOR(I,J)=270. 121
GO TO 6 122
4 RCOR(I,J)=90. 123
GO TO 6 124
5 RCOR(I,J)=90. 125
GO TO 6 126
2 RCOR(I,J)=(ATAN(Y(J)/X(J)))*57.3 127
IF(X(J).LT.0.)RCOR(I,J)=180.+RCOR(I,J) 128
IF(X(J).GT.0..AND.Y(J).LT.0.)RCOR(I,J)=360.+RCOR(I,J) 129
6 CONTINUE 130
RETURN 131
END 132
```

6. Sunk survey data: program to calculate relative velocities and produce the distributions by different ranges of relative velocity

```
MASTER 1
C SUNK SURVEY DATA 2
C E IS NUMBER,T IS TIME.P IS POSITION,BL IS LENGTH BP, 3
C C IS GROSS TONNAGE 4
C M IS NUMBER OF OBSERVATIONS 5
DIMENSION N(50,3),BL(300),E(300),XA(300),YA(300), 6
XB(300),YB(300),T(300),C(300),P(300),NN(50,3,10),SNE(50,3),
SNV(50,3),SNW(50,3),NCUM(50,3),SNWCUM(50,3),TOT(50,3),
SLO(50,3),ISIGN(50,3)
DO 2 J=1,3 7
DO 2 I=1,50 8
2 N(I,J)=0 9
DO 4 I=1,50 10
DO 4 J=1,3 11
DO 4 L=1,10 12
4 NN(I,J,L)=0 13
READ(1,997) ISURVEY 14
997 FORMAT(I1) 15
READ(1,990) IHOURS 16
990 FORMAT(I2) 17
WRITE(6,996) ISURVEY, IHOURS 18
996 FORMAT(2I2) 19
DO 13 K=1, IHOURS 20
READ(1,999) M 21
999 FORMAT(I5) 22
DO 1 I=1, M 23
1 READ(1,998) E(I), XA(I), YA(I), SB(I), YB(I), T(I), P(I), BL(I), 24
C(I)
998 FORMAT(9F0.0) 25
DO 3 I=1, M 26
IF(YA(I)*YA(I)+XA(I)*XA(I).GT.9.) GO TO 3 27
IF(C(I).EQ.9..OR.C(I).EQ.8.) GO TO 3 28
IF(P(I).NE.0.) GO TO 3 29
DO 9 J=1, M 30
IF(E(I).EQ.E(J).OR.T(I).NE.T(J)) GO TO 9 31
XAR=XA(J)-XA(I) 32
YAR=YA(J)-YA(I) 33
XAC=XB(I)-XA(I) 34
YAC=YB(I)-YA(I) 35
XARV=XB(J)-XA(J)-XB(I)+XA(I) 36
YARV=YB(J)-YA(J)-YB(I)+YA(I) 37
CALL RELVELSUNK(R,B,XAR,YAR) 38
IF(R.GT.50.) GO TO 9 38
CALL RELVELSUNK(RR,RC,XAC,YAC) 40
B=RC-B 41
IF(B.LT.0.) B=360.+B 42
CALL COUNT(F,FA,N,R,B) 43
IF(B.GE.0..AND.B.LT.112.5) JN=1 44
CALL RELVELSUNK(RV,RCOR,XARV,YARV) 45
LN=INT(RV/5.)+1 46
IF(B.GE.112.5.AND.B.LT.247.5) JN=3 47
IF(B.GE.247.5.AND.B.LE.360.) JN=2 48
IN=INT(R)+1 49
NN(IN,JN,LN)=NN(IN,JN,LN)+1 50
9 CONTINUE 51
3 CONTINUE 52
13 CONTINUE 53
```

| | |
|--|----|
| WRITE (6,991) ((N(I,J),I=1,50),J=1,3) | 54 |
| 991 FORMAT (25I3/25I3) | 55 |
| DO 5 LN=1,10 | 56 |
| DO 5 JN=1,3 | 57 |
| WRITE (6,983) LN, JN | 58 |
| 983 FORMAT (1H ,5HSPEED,2X,I2,2X,6HSECTOR,2X,I1) | 59 |
| WRITE (6,986) (NN(IN,JN,LN),IN=1,50) | 60 |
| 986 FORMAT (25I3/25I3) | 61 |
| 5 CONTINUE | 62 |
| WRITE (6,982) LN | 63 |
| 982 FORMAT (1H ,5HSPEED,2X,I2) | 64 |
| DO 7 LN=1,10 | 65 |
| DO 8 JN=1,3 | 66 |
| DO 8 IN=1,50 | 67 |
| N(IN,JN)=NN(IN,JN,LN) | 68 |
| 8 CONTINUE | 69 |
| CALL SMOOTH(SNE,SNV,SNW,N) | 70 |
| CALL CUMULATE(N,NCUM,SNW,SNWCUM) | 71 |
| CALL DOMAIN(SNW,SNWCUM,TOT,SLO,ISIGN,NCUM) | 72 |
| 7 CONTINUE | 73 |
| STOP | 74 |
| END | 75 |

7. Simulator data: program to produce distributions by other variables for the central ship.

The main difference between this and the relative velocity program for the simulator data is that the gross tonnages have to be assigned correctly to each encounter but no calculations have to be made. This can be done by omitting statements 24-59 and substituting the following statements

| | |
|-----------------|-----|
| RC(1)=C(1) | 24' |
| RC(2)=C(2) | 25' |
| RC(3)=C(1) | 26' |
| RC(4)=C(3) | 27' |
| RC(5)=C(2) | 28' |
| RC(6)=C(3) | 29' |
| DO 15 J=1,IT | 30' |
| I=6+J | 31' |
| 15 RC(I)=C(1) | 32' |
| DO 16 J=1,IT | 33' |
| I=6+IT+J | 34' |
| 16 RC(I)=C(2) | 35' |
| DO 17 J=1,IT | 36' |
| I=6+2*IT+J | 37' |
| 17 RC(I)=C(3) | 38' |
| GO TO 13 | 39' |
| 14 DO 18 I=1,IT | 40' |
| 18 RC(I)=C(1) | 41' |
| DO 19 I=1,IT | 42' |
| I=I+IT | 43' |
| 19 RC(I)=C(2) | 44' |
| DO 21 I=1,IT | 45' |
| I=2*IT+I | 46' |
| 21 RC(I)=C(3) | 47' |

| | |
|--|----|
| WRITE (6,991) ((N(I,J),I=1,50),J=1,3) | 54 |
| 991 FORMAT (25I3/25I3) | 55 |
| DO 5 LN=1,10 | 56 |
| DO 5 JN=1,3 | 57 |
| WRITE (6,983) LN, JN | 58 |
| 983 FORMAT (1H ,5HSPEED,2X,I2,2X,6HSECTOR,2X,I1) | 59 |
| WRITE (6,986) (NN(IN,JN,LN),IN=1,50) | 60 |
| 986 FORMAT (25I3/25I3) | 61 |
| 5 CONTINUE | 62 |
| WRITE (6,982) LN | 63 |
| 982 FORMAT (1H ,5HSPEED,2X,I2) | 64 |
| DO 7 LN=1,10 | 65 |
| DO 8 JN=1,3 | 66 |
| DO 8 IN=1,50 | 67 |
| N(IN,JN)=NN(IN,JN,LN) | 68 |
| 8 CONTINUE | 69 |
| CALL SMOOTH(SNE,SNV,SNW,N) | 70 |
| CALL CUMULATE(N,NCUM,SNW,SNWCUM) | 71 |
| CALL DOMAIN(SNW,SNWCUM,TOT,SLO,ISIGN,NCUM) | 72 |
| 7 CONTINUE | 73 |
| STOP | 74 |
| END | 75 |

7. Simulator data: program to produce distributions by other variables for the central ship.

The main difference between this and the relative velocity program for the simulator data is that the gross tonnages have to be assigned correctly to each encounter but no calculations have to be made. This can be done by omitting statements 24-59 and substituting the following statements

| | |
|-----------------|-----|
| RC(1)=C(1) | 24' |
| RC(2)=C(2) | 25' |
| RC(3)=C(1) | 26' |
| RC(4)=C(3) | 27' |
| RC(5)=C(2) | 28' |
| RC(6)=C(3) | 29' |
| DO 15 J=1,IT | 30' |
| I=6+J | 31' |
| 15 RC(I)=C(1) | 32' |
| DO 16 J=1,IT | 33' |
| I=6+IT+J | 34' |
| 16 RC(I)=C(2) | 35' |
| DO 17 J=1,IT | 36' |
| I=6+2*IT+J | 37' |
| 17 RC(I)=C(3) | 38' |
| GO TO 13 | 39' |
| 14 DO 18 I=1,IT | 40' |
| 18 RC(I)=C(1) | 41' |
| DO 19 I=1,IT | 42' |
| I=I+IT | 43' |
| 19 RC(I)=C(2) | 44' |
| DO 21 I=1,IT | 45' |
| I=2*IT+I | 46' |
| 21 RC(I)=C(3) | 47' |

The numbering of the classes of gross tonnage cannot be done so simply as in statement 62 but must be identified according to the appropriate tonnage divisions:

e.g. Class 3 all tonnage between 4000 and 9000 g.r.t.

Otherwise only minor changes are needed in case there are more subdivisions of the variable and so that the correct formats appear.

The programs for distributions by maximum speed and experience can similarly be formed, changing C to S and then to E respectively, making any dimensional changes necessary.

8. Sunk survey data: programs to produce distributions by other variables for the central ship.

The Sunk programs can be adapted in a similar manner as the simulator programs were from the relative velocity one. This applies to gross tonnage and length.

The fishing vessel and channel programs can be obtained easily from the basic program by changing the exclusions for the central ship.

9. Sunk survey data: program to calculate the distributions of ships around buoys.

```
C PROGRAM TO COMPUTE DOMAIN WRT BUOYS
  DIMENSION N(50,3)
  DIMENSION E(300),XA(300),YA(300),XB(300),YB(300),T(300),
  C(300),P(300),BL(300)
  DIMENSION SNE(50,3),SNV(50,3),SNW(50,3),NCUM(50,3),SNWCUM(50,3)
  DIMENSION TOT(50,3),SLO(50,3),ISIGN(50,3)
  DIMENSION EB(10),XC(10),YC(10)
  DO 2 J=1,3
  DO 2 I=1,50
  2 N(I,J)=0
  READ (1,997) ISURVEY
997 FORMAT(I1)
  READ(1,990) IHOURS
990 FORMAT(I2)
  WRITE (6,996) ISURVEY, IHOURS
996 FORMAT(2I2)
  DO 1 J=1,10
  1 READ(1,995) EB(J),XC,(J),YC(J)
  DO 13 K=1, IHOURS
995 FORMAT(3F0.0)
  READ(1,999) M
999 FORMAT(I5)
  DO 3 I=1, M
  READ (1,998) E(I),XA(I),YA(I),XB(I),YB(I),T(I),P(I),BL(I),C(I)
998 FORMAT(9F0.0)
```

```
DO 9 J=1,10
IF (E(I).EQ.E(J).OR.T(I).NE.T(J)) GO TO 3
XAR=XA(J)-XA(I)
YAR=YA(J)-YA(I)
XAC=XB(I)-XA(I)
YAC=YV(I)-YA(I)
CALL RELVELSUNK(R,B,XAR,YAR)
IF(R.GT.50.) GO TO 3
CALL RELVELSUNK(RR,RC,XAC,YAC)
B=RC-B
IF(B.LT.0.)B=360.+B
CALL COUNT(F,FA,N,R,B)
9 CONTINUE
3 CONTINUE
13 CONTINUE
WRITE(6,991)((N(I,J),I=1,50),J=1,3)
991 FORMAT(25I3/25I3)
CALL SMOOTH(SNE,SNV,SNW,N)
CALL CUMULATE(N,NCUM,SNW,SNWCUM)
CALL DOMAIN(SNW,SNWCUM,TOT,SLO,ISIGN,NCUM)
STOP
END
```

List of Symbols

The following list contains the symbols used most frequently in the text together with a short definition. The page reference refers to the first point in the text where they were introduced and hence where a full definition can be found.

- θ Bearing of another ship relative to the central ship i.e. the angle measured clockwise between the heading of the central ship and the line joining the two ships. p.59.
- K Uniform density per square mile in an area under observation p.85.
- α Constant of uniform density p.85.
- x_E Distance from the central ship below which no ship was observed to go p.86.
- x_A Distance from the central ship at which the observed distribution of ships first cuts the line of uniform density p.86.
- x_D Distance from the central ship at which the observed distribution of ships has a local maximum p.86. X
- x_C Distance from the central ship after which the observed distributions of ships may be considered to follow a line of uniform density p.86.
- y_d Distribution of ships in the presence of the domain p.87. s
- x_B Distance from the central ship at which the observed density curve of ships has its overall maximum p.96. X
- $E(x)$ Smoothed value of a curve p.98.
- $Y(x)$ Actual value of a curve p.98.
- a Smoothing coefficient for exponential smoothing p.98.
- C_i Cumulative total of ships in a sector of outer radius x_i p.104.
- β
 γ Parameters in a sine curve approximation to the observed distribution of ships p.104. Wk / s
- x_F An arbitrary distance from the central ship used in fitting a sine curve to the observed distribution of ships p.106.
- m_i Mean radius of a band of outer radius x_i and inner radius x_{i-1} p.111.
- y_i Number of ships in part of a band of mean radius m_i p.111. X

- $\hat{\alpha}$ An estimate of α , the constant of uniform density p.104.
- T_i Estimated cumulative total of ships in a sector of outer radius x_i p.112.
- x_i^* An estimate of x_C p.112.
- y_i^* $y_i^* = 2\alpha x_i^*$ p.112.
Thus (x_i^*, y_i^*) are the estimated coordinates of the point C after which the observed distribution of ships follows the line of uniform density
- y_{si} Smoothed number of ships in a sector of a band of mean radius m_i p.112.
- T_{si} Estimated smoothed cumulative total of ships in a sector of outer radius x_i p.113.
- C_{si} Actual cumulative total of ships in a sector of outer radius x_i p.113.
- $\bar{\alpha}$ Mean value of estimates for α p.122.
- \hat{x}_A Estimate of x_A p.126.
- $x_{Ai \text{ Dover}}$ Domange for the i^{th} sector in the Dover Strait p.136.
- $x_{Ai \text{ Sunk}}$ Domange for the i^{th} sector in the Sunk area p.136.

Notes on Tables and Figures

Chapter 1

- Table 1.1 Source: Thompson (1972)⁽¹⁾.
- Table 1.2 Source: Thompson (1972)⁽¹⁾
The figures for 1980 are based on the assumptions that current trends in birth rates etc. will continue but that there will be no sudden changes such as wars altering the utilisation of trade routes.
- Table 1.3 Source: Lloyds Register of shipping (1963)⁽⁴³⁾ and 1973⁽⁴⁴⁾.
- Table 1.4 Source: Shell International Marine Ltd. (1968)⁽⁴⁵⁾.
- Table 1.5 Source: Liverpool Underwriters Association (1973)⁽²⁾.

Each time a ship is a casualty during a year, the nature of the casualty is recorded under the major category only. It is however, possible for any one ship to be a casualty on more than one occasion during a year.

Chapter 3

- Table 3.1 (a) As the table contains the distribution of experience considering each exercise separately, any one person is usually recorded several times in the table.
(b) The category 'length of experience not known' contained two people in shore jobs and six people for whom full details on the course were not readily available.
- Table 3.2 The large number of ships in the 10,000 g.r.t. category arises because this is the category used in the first exercises when all students are placed in identical situations in similar ships.
- Table 3.3 The large number of ships of maximum speed 16 knots arises because this is the maximum speed assumed in the early exercises when all students are placed in identical situations in similar ships.
- Table 3.4 (a) The number of six minute intervals recorded is for each survey less than the number which might have been expected given the duration of the survey. This is because of the loss of photographs for various reasons.
(b) The positions of the M.V. 'Sir John Cass' quoted are only approximate positions.
- Table 3.5 (a) The size of ship was obtained from Lloyds Register of Shipping (1972)⁽²⁷⁾.
(b) Some ferries were included by size where this was known but the others were put in the category 'ferry'. No ship was included twice.

Table 3.6 The length of ship between perpendiculars was obtained from Lloyds Register of Shipping (1972)⁽²⁷⁾.

Chapter 4

The sectors are defined on p.

Figs. 4.4) These three figures show by sector the distribution of
4.5) ships around a central ship for all exercises combined
4.6) in the simulator data. Only 'own' ships were included
as central ships.

Figs. 4.8) These three figures show by sector the distribution of
4.9) ships around a central ship for survey 2 of the Sunk
4.10) surveys. One graph has no exclusions as central ship.
The second excludes the pilot boat, ships within one mile
of it, ships in the channel area and ships on the edge
of the area, as central ship. The third excludes
additionally fishing vessels as central ship.

Chapter 5

Notes general to all tables, and figures based on data collected.

- (a) The sectors are defined on page
- (b) The tables using the simulator data are based on the results when the first two time points of every exercise are excluded.
- (c) The tables using the Sunk survey data are based on the results when ships more than 3 miles distant from the centre of the radar screen are excluded as central ship. Also excluded as central ship are fishing boats, the pilot boat and ships within one n.mile radius of it, and any ships in the buoyed channel defined on p. The behaviour of central ships with respect to these categories of ships is considered.
- (d) The quoting of results to 2 decimal places is not really justified if the sample sizes are small.

Notes on particular tables.

Table 5.1 The sample size refers to the number of own ships.

- Table 5.16) (a) A value is in the direction of the domain if it is
5.17) the side of the uniform density line agreeing with the
concept of a domain.
- (b) If not it is considered as a value against the domain.
 - (c) The probabilities in the final column are evaluated by considering the probability of getting the observed number of values against the domain or less if each value has an equal chance of lying either side of the uniform density line.

Chapter 6

- (a) The general notes to the tables and figures based on data collected given for Chapter 5 are applicable in nearly all cases here except where stated otherwise.
- (b) The figures in brackets in each table refer to the sample size on which the estimates are made.
- (c) The sample sizes shown by the separate categories will not always add to the sample size given for the total because of the omission of certain categories.

Notes on particular tables

Table 6.2 The figures for a gross tonnage of 10,000 are given separately because this is the size of ship used in the early exercises when all students have similar ships.

Table 6.3 Some ferrys have been included in their appropriate size category.

Appendix I

Table I.1 Source: Thompson (1972)⁽¹⁾.

Table I.2 Source: Lloyds Register of Shipping (1963)⁽⁴³⁾ and 1973⁽⁴⁴⁾.

Appendix III

Table III.3 Source: Lloyds Register of Shipping (1972)⁽²⁸⁾.

Appendix V

See the general notes to Chapter 5.

Table V.1) The sample sizes refer to the number of own ships
Table V.2)

Table V.4 The definitions of the symbols are given on p.
Table V.5
Table V.6

Appendix VI

See the general notes to Chapter 6.

Table VI.2) See the note for table 6.2
Table VI.3)

Table VI.4 See the note for table 3.1

References

1. Thompson R.P. (1972) Estimating Global Traffic Flows. Journal of Navigation Vol.25, p.384
2. Liverpool Underwriters Association (1973) Annual reports.
3. Oudet L. (1968) The Black Flood: Lessons of the 'Torrey Canyon'. Journal of the Institute of Navigation. Vol.21, p.41.
4. Vanags A.H. (1972) The Application of the Economics of Congestion to Marine Problems. Conference on Marine Traffic Engineering (see (15)).
5. Silverleaf A. (1972) Marine Traffic Engineering: An Introduction. Paper presented at the conference on Marine Traffic Engineering May 1972.
6. Kemp J.F. (1974) Factors in the Prevention of Collisions at Sea. Ph.D. thesis CNA 1974.
7. Parker E. and Le Page L.S. (1949) Operational factors and operational yields. Journal of the Institute of Navigation. Vol.2, p.95.
8. Sasieni, Yaspan and Friedman Operations Research - methods and problems. First published 1959. John Wiley.
9. Beattie J.H. (1968) Operational Research into Marine Traffic and Collisions. Journal of the Institute of Navigation. Vol.21, p.490.
10. National Physical Laboratory (1971) Marine Traffic in the Dover Strait. An exploratory Survey and Analysis of Collisions. December 1971.
11. NPL Report Mar. Sci. 7-72. (1972) Marine traffic in the Dover Strait. Summary of surveys conducted during 1971.
12. Waddington C.H. (1973) OR in World War 2. Operational Research against the U Boat. Publ: Elek Science.
13. Hargreaves E.R. (1973) 'Safety of Navigation in the English Channel' Journal of Navigation, Vol26, p.399.
14. Toyoda S. and Fujii Y. (1971) Marine Traffic Engineering. Journal of the Institute of Navigation, Vol.24, p.24.
15. Marine Traffic Engineering Proceedings of a conference organised jointly by the Royal Institution of Naval Architects and the Royal Institute of Navigation (1973).
16. Hall E.T. (1955) The anthropology of manners. Scientific American, V192, p.84-90.

17. Little K.B. (1965) "Personal Space" Journal Experimental Psychology, Vol.I p.237-47.
18. Ministry of Transport (1968) 'The Highway Code', Section 35.
19. Reich P.G. (1964) A Theory of Safe Separation Standards for Air Traffic Control. RAE Technical Report No.64041.
20. Reich P.G. (1964) An Analysis of Planned Aircraft Proximity and its Relation to Collision Risk, with special reference to the North Atlantic Region. RAE Technical Report No.64042.
21. International Rules for preventing collisions at sea (1960).
22. Brown I.S.H. and Wheatley J.H.W. (1972) Circumstances of Collisions and Strandings in the Dover Strait Area (1958-1971). NPL Report Mar. Sci. R101 (1972).
23. Fujii Y. and Tanaka K. (1971) Traffic Capacity. Journal of the Institute of Navigation Vol.24 p.543.
24. Barratt M.J. (1973) Encounter Rates in a Marine Traffic Separation Scheme. Journal of Navigation Vol.26 p.458.
25. Draper J. and Bennett C. (1972) 'Modelling encounter rates in marine traffic flows with particular application to the Dover Strait'. Journal of Navigation, Vol.25, p.381.
26. Yamaguchi A. and Sakaki S. Traffic Surveys in Japan. Journal of the Institute of Navigation (1971). 24.4.
27. Lloyd's Register of Shipping Register Book 1971/72 1972/73 Register of Ships.
28. Lloyd's Register of Shipping Statistical Tables (1972).
29. Kendall M.G. and Stuart A. The Advanced Theory of Statistics Vol.III. Published by Griffin.
30. Kruskal, W.H. and Wallis W.A. (1952) Use of ranks in one-criterion variance analysis. J. Americal Statistical Association 47, 583-621.
31. Kruskal W.H. (1952) A non-parametric test for the several sample problem. Ann. Mathem. Statist. 23, 525-540.
32. Andrews F.C. (1954) Asymptotic behavior of some rank tests for analysis of variance. Ann. Math. Statist. 25, 724-736.
33. Mood A.M. (1954) On the asymptotic efficiency of certain non-parametric two-sample tests. Ann. Math. Statist. Vol.25, p.514-522.
34. Van Hooff J.F. Drijfhout (1971) The Air Analogy at Sea. Journal of the Institute of Navigation Vol.24, p.349.

35. Schimmel N. (1972) Traffic Regulation in Europoort and its Approaches. Conference on Marine Traffic Engineering (see (15)).
36. Goodwin E.M. (1972) Traffic Distribution and Collision Rate/Size Correlations Derived from Dover Strait's Data. Journal of Navigation, Vol.25, p.370.
37. Stratton A. (1971) Navigation Traffic and the Community. Journal of the Institute of Navigation, Vol.24, p.1.
38. May G.T.A. (1971) A method for predicting the number of near mid-air collisions in a defined airspace. Journal of Navigation (1971) Vol.24, p.204.
39. Oshima R. and Fujii Y. (1974) The diameter of evasion for crossing encounters. Journal of Navigation. Vol.27, p.235.
40. The Institute of Navigation The Use of Radar at Sea. Published by Hollis and Carter.
41. Mann H.B. and Whitney D.R. (1947) On a test of whether one of two random variables is stochastically larger than the other. Ann. Math. Statist. Vol.18, p.50-60.
42. Siegel S. Non-parametric statistics for the behavioural sciences. Published by McGraw-Hill.
43. Lloyds Register of Shipping (1963) Statistical Tables.
44. Lloyds Register of Shipping (1973) Statistical Tables.
45. Shell International Marine Ltd. (1968) Tanker Manoeuvring Characteristics. Shell International Marine Ltd. (MRT/31) London.

Attention is drawn to the fact that the copyright of this thesis rests with its author.

This copy of the thesis has been supplied on condition that anyone who consults it is understood to recognise that its copyright rests with its author and that no quotation from the thesis and no information derived from it may be published without the author's prior written consent.

I

D50265'84

END