

# A Survey of MAC Layer Issues and Protocols for Machine-to-Machine Communications

Ajinkya Rajandekar and Biplab Sikdar

**Abstract**—With the growing interest in the use of autonomous computing, sensing and actuating devices for various applications such as smart grids, home networking, smart environments and cities, health care etc., machine-to-machine (M2M) communication has become an important networking paradigm. However, in order to fully exploit the applications facilitated by M2M communications, adequate support from all layers in the network stack must first be provided in order to meet their service requirements. This paper presents a survey of the requirements, technical challenges, and existing work on Medium Access Control (MAC) layer protocols for supporting M2M communications. The paper first describes the issues related to efficient, scalable and fair channel access for M2M communications. Then, in addition to protocols that have been developed specifically for M2M communications, the paper reviews existing MAC protocols and their applicability to M2M communications. This survey paper then discusses ongoing standardization efforts and open problems for future research in this area.

**Index Terms**—MAC protocol, M2M communications, IoT.

## I. INTRODUCTION

Machine-to-Machine communications constitute the basic communication paradigm in the emerging Internet-of-Things (IoT) and involves the enabling of seamless exchange of information between autonomous devices without any human intervention. The services facilitated by M2M communications encompass both personal, public, and professional spaces and scenarios of interest include smart power grids, intelligent spaces, smart cities, industry automation, health care, etc. just to name a few. The increasing popularity of services and systems based on the use of M2M communications has been fueled in part by the utility of the applications they facilitate, as well as by the continued fall in the prices of autonomous devices capable of sensing and actuating. The number of devices based on M2M communication is poised for extensive growth in the near future with predicted compound annual growth rates of greater than 25% [1]. The increasing M2M traffic and the associated revenue have created an interest among telecom operators as well as regulatory and standardization bodies to facilitate M2M communications.

The unique characteristics of M2M communications introduce a number of networking challenges. Most applications and scenarios based on M2M communications usually involve a very large number of devices and a fundamental issue is the efficient management of network resources. In addition to scalability, the network also has to consider the traffic characteristics and cater to the quality of service (QoS) requirements. For example, in a home setting, M2M devices may randomly and infrequently send small bursts of data or transmit a fixed amount of data periodically. Also, the service requirements

of applications using M2M communications may be different from existing applications and will also vary within the M2M based applications. For example, in certain applications it may be required to provide highly reliable communication with QoS guarantees thus requiring prioritized assignments. A significant fraction of the devices involved in M2M communications are expected to be battery operated. Consequently, lowering the communication related power consumption is an important design objective for the network. Finally, as M2M communication is primarily “hands off” (i.e. free from human intervention), the M2M communication network must be self-capable in various aspects such as organization, configuration and healing. These requirements and characteristics affect all the layers in the networks stack and make network support for M2M communications a challenging area of research at different levels.

In this paper, we consider the MAC layer issues related to M2M communications. The MAC layer is primarily responsible for channel access for nodes within a network that use a shared medium. The critical MAC layer challenge for M2M communications lies in facilitating channel access to extremely large number of devices while supporting the diverse service requirements and unique traffic characteristics of devices in M2M networks. In addition, MAC protocols for M2M communications should be efficient, scalable, consume low power, have low latency, and be implementable using low cost hardware. Channel access for scenarios with very large number of devices has the potential to become a bottleneck, as foreseen by the industry and standardization bodies [2], [3], [4]. Consequently, development of MAC layer protocols and technologies for M2M communications is an area of considerable importance to both researchers and practitioners.

This paper reviews the key MAC layer protocols that have been proposed for M2M networks. In addition, we also evaluate MAC protocols for general wireless networks in terms of their suitability for M2M communications. This paper classifies the protocols into three classes: contention-based protocols, contention-free protocols, and hybrid protocols which incorporate advantages of contention-free and contention-based protocols while trying to alleviate their weaknesses. The effectiveness of these protocols in the context of M2M communications is discussed, along with their advantages and weakness. In addition, open research problems and ongoing standardization efforts in the area of M2M communications are also discussed.

The rest of the paper is organized as follows. In Section II we discuss the key features that MAC protocols should possess in order to satisfy the demands of M2M communications.

Section III, describes existing contention-based, contention-free, and hybrid wireless MAC protocols and their application to M2M communications. Section IV describes MAC protocols that have been developed specifically for M2M communications while Section V reviews the literature on the performance evaluation of such MAC protocols. In Section VI we discuss the avenues for future work in this area and also describe the standardization efforts on MAC protocols for M2M communications. Finally, Section VII concludes the paper.

## II. REQUIREMENTS OF MAC PROTOCOLS FOR M2M COMMUNICATION

MAC protocols for supporting M2M communications have to be designed with a rich set of requirements in order to satisfy the needs of the overlaying applications and scenarios. This section describes these requirements in detail.

### A. Data Throughput

The first characteristics that MAC protocols for M2M communications needs to possess are high efficiency and throughput. Due to the limited channel/spectrum resources and a large number of devices accessing the channel, it is desirable that the MAC protocol minimizes the time wasted due to collisions or exchange of control messages. Equivalently, the throughput has to be high in order to accommodate the very large number of devices. Collisions are the main cause of concern in contention-based systems due to their negative impact on the throughput performance of the system. In addition, because of the hidden terminal problem, collisions are even more difficult to tackle in M2M networks. In contention-free, schedule based systems, the control overhead and empty slots are important issues affecting the throughput performance. Note that if the control overhead of a protocol is large, it affects the *effective* throughput (i.e. the data bits transmitted per unit time) even though the physical data rate may not be affected. In addition, it is required that the effective throughput remain high irrespective of the traffic levels.

### B. Scalability

In the context of M2M communications, a key consideration for MAC protocols is scalability. Scenarios with M2M communications are expected to have a large number of nodes. The node density is expected to increase as the deployment of application scenarios with M2M communications becomes more prevalent. In addition, the network conditions may be dynamic, with nodes entering and leaving (or alternating between active and inactive states). Thus it is imperative that the MAC protocol be easily scalable and adjust gracefully to changing node densities with little or no control information exchange, and maintain fairness even after the addition of new devices. While there is no additional control overhead in contention-based MAC protocols like CSMA/CA or ALOHA when the number of nodes increases, their performance usually degrades due to factors such as collisions. On the other hand, contention-free protocols like TDMA and even hybrid

ones usually require reassignment of resources and should be designed so that they easily accommodate nodes joining or leaving the network without requiring any major network reorganization.

### C. Energy Efficiency

Energy efficiency is one of the most important design considerations for M2M communications because of three main factors. The first is the fact that many of the devices in M2M networks are expected to be battery operated and thus power constrained. The second is the economic impact (such as operational costs and profit margins) of the power consumed by the communication infrastructure. Finally, the third factor is the environmental impact of the power consumed. The information and communications industry is currently responsible for 1.3% of total harmful emissions in the world [5]. This number is expected to increase with the explosion of M2M devices in the coming decade. Considering all three factors, it is thus imperative that all operations associated with M2M communications be optimized to consume very low power. For the battery operated M2M devices, two major contributors of power consumption are the energy spent on the radio transmissions and the channel access. Collisions during channel access are a major cause of power consumption that should be reduced to the greatest extent possible, as is the power consumed due to the transmission of control information. For example, at high loads the control overhead may consume almost 50% of the total energy in the IEEE 802.11 MAC protocol [6]. Common methods to reduce the MAC layer energy consumption include reducing the collisions, sleep scheduling, power control, reducing idle listening etc.

### D. Latency

For many of the applications that rely on M2M communications, the network latency is a critical factor that determines the effectiveness and utility of the offered services. For example, in scenarios such as intelligent transportation systems with real-time control of vehicles, e-health applications etc., it is extremely important to make the communication reliable and fast. Thus delays during channel access or network congestion are serious issues in M2M networks. Also, even if a MAC protocol is throughput efficient, it has to ensure both long term and short term fairness so that all devices get equal chance (or a chance proportional to their priority) to send their messages. Also, we note that while it is always desirable to reduce the channel access latency, there are limitations to it, specially when the number of nodes increases.

### E. Coexistence

Due to the spectrum costs associated with operating in licensed bands, a significant fraction of the access networks for M2M communications are expected to operate in the unlicensed bands. With widespread deployment of M2M devices, it is likely that multiple M2M access networks will be deployed in close proximity and independently in the same unlicensed based. In addition to coexisting with other M2M

networks, they also have to coexist with other networks that traditionally operate in the unlicensed band (e.g. WiFi and Bluetooth). While problems such as interference generated in these scenarios and bandwidth sharing may be addressed at both the physical and MAC layers, issues such as the collisions due to hidden terminals from neighboring networks has to be addressed at the MAC layer.

#### F. Cost Effectiveness

Finally, in order to make M2M communication based systems a reality, the devices must be cost effective so that it is affordable to deploy them. A MAC protocol that has many desirable properties but relies on the use of costly, complex hardware, is not practical. Although advances in manufacturing of semiconductor devices has led to a continued fall in the prices of electronic systems, when it comes to large scale deployments, low cost of devices is a necessity from a marketing and economic perspective. Therefore the MAC protocol should be designed to work effectively on simple hardware. Finally, cost as well as physical form factor requirements may also impact the choice of the hardware and the protocols that may be used on them. For example, small devices such as many sensors may find it difficult to have multiple transmitting and receiving antennas and thus preclude them from using protocols such as IEEE 802.11n. In addition to the physical limitations imposed by the small form factor, cost may also be an issue in determining the capabilities of the physical layer radio system.

#### G. Example Scenario

To highlight the various requirements listed above in a scenario with M2M communications, we consider smart homes as an example. Technology for smart homes is evolving rapidly and we consider three of its many services: (i) power management for reducing energy cost, (ii) security and (iii) assistive services for the elderly. To a large extent, these services are based on the use of devices, sensors and actuators that operate using M2M information exchange. To facilitate fine-grained energy management of homes, each appliance and electrical device may have a communication interface that sends and receives data and commands to control its operation. In addition, each room may have its own internet connected thermostats and smoke detectors. A home energy management system may also include smart meters, solar panels, inverters, and storage devices. A home security system may consist of multiple cameras, motion sensors in rooms, and reed switches at doors and windows for perimeter security. These devices generate data at various rates which may be transferred to an off-site control station (e.g. owned by a security services company) for analysis and action. Finally, assisted living facilities depend on the data generated by multiple on-body sensors for physiological data, bio-sensors, sensors to detect functional decline in older adults (e.g. measuring restlessness in bed), sensors for fall detection, infrared sensors, and video cameras. The number of devices in a smart home can thus easily run into many tens to hundreds of nodes.

The diverse range of devices that are required to support the services expected from a smart home generate different performance requirements from the underlying MAC protocol. For example, the cameras in use for home security require MAC protocols with high throughput while sensors in use for assisted living and medical applications have strict delay requirements. Also, the large number of nodes in close proximity that share a single channel for wireless access gives rise to the requirement for scalability of the MAC protocol. The fact that many of the sensors are battery operated leads to the requirement of energy efficiency. Finally, the requirement for a cost-effective solution for the smart home services that need a large number of sensors, requires MAC protocols that can be employed with low-cost hardware. Existing solutions for wireless access such as random access or polling based MAC protocols do not, simultaneously, cater to the diverse set of requirements that arise in this example scenario. In addition, as described in the subsequent sections, they are unable to scale to handle the large number of devices that occur in this scenario.

### III. GENERAL WIRELESS MAC PROTOCOLS

The design and development of MAC protocols for wireless environments is a rich field that has received extensive attention in existing literature. Existing MAC protocols can be broadly classified as contention-based, contention-free, or hybrid protocols that combine aspect of contention-free and contention-based protocols. This section presents an overview of these protocols and discusses their appropriateness in the context of M2M communications.

#### A. Contention-Based MAC Protocols

Contention-based MAC protocols are among the simplest protocols in terms of setup and implementation. In these protocols the nodes contend for the channel in various ways in order to acquire the channel and transmit data. The main disadvantage of these protocols is the lack of scalability, particularly due to the increase in the number of collisions between concurrent transmission from different nodes as the number of nodes increases.

1) *Random Access Protocols*: In the earliest random access protocols such as ALOHA and slotted-ALOHA, nodes with data to send transmit the packet as soon as it arrives, or send it at the beginning of the next slot, respectively [7], [8]. The main drawback of these protocols is the high rate of collisions which limits the asymptotic throughput values to 18% and 36%, respectively, of the channel bandwidth [8]. Carrier Sense Multiple Access (CSMA) based protocols are a step towards reducing the collisions suffered by ALOHA type protocols [9]. CSMA does not eliminate collisions and may experience throughput degradation due to the hidden and exposed terminal problems. The hidden terminal problem may be solved by the use of busy tones where transmitters and/or receivers are required to transmit a constant busy tone while a packet is being transmitted or received [10], [11]. Single channel solutions for reducing the hidden terminal problem

are primarily based on the Multiple Access with Collision Avoidance (MACA) protocol [12].

One of the most widely deployed random access protocols is IEEE 802.11 and is based on CSMA with collision avoidance (CSMA/CA) [13]. The performance of IEEE 802.11 has been widely investigated [14], [15]. While the protocol performs well for small network sizes, as the number of active nodes increases, its performance in terms of delay and throughput degrades quickly, especially when each node's load approaches saturation. Considerable research has been devoted to improve the performance of IEEE 802.11 and many variations to it have been proposed [16], [17], [18], [19]. While these advancements address one or more performance issues associated with IEEE 802.11, the fundamental issues with random access based channel access still remain.

2) *M2M Communications and Contention-Based Protocols:* Contention based MAC protocols are largely unsuited for M2M communications due to the collisions and the resulting poor performance as the node density increases (for example in ALOHA and CSMA based protocols). Busy tone based protocols such as Dual Busy Tone Multiple Access (DBTMA) [11] offer better performance. However, this comes at the price of additional hardware cost and complexity (two radio transmitters, bandwidth requirement for busy tone etc.) which limits its applicability for low cost M2M devices.

CSMA/CA based protocols such as IEEE 802.11 are among the most widely deployed MAC protocols. However, their ability to meet the requirements for M2M communication leaves much to be desired. This is primarily due to their inability to scale as the network size increases. Other concerns are the energy wasted by CSMA/CA based protocols due to collisions and idle listening, and the overhead of control packets which may consume more energy than the data packets (due to higher collision probabilities for control packets) [6].

### B. Contention-Free MAC Protocols

Contention free protocols eliminate the issue of collisions by pre-allocating transmission resources to the nodes in the network. Common contention-free protocols include time division multiple access (TDMA), code division multiple access (CDMA), and frequency division multiple access (FDMA). In FDMA, a fraction of the frequency bandwidth is allocated to each user all the time while in TDMA, the entire bandwidth is allocated to a user for a fraction of time [20], [21]. CDMA operates by assigning orthogonal codes to each user which are then used to modulate the bit patterns [22], [23]. Static contention-free protocols have a fixed number of resources: time slots, frequency bands and orthogonal codes that need to be assigned to the users. Such protocols have limited flexibility in the presence of dynamic network conditions and are not very efficient at low loads. The solution to these issues is usually the use of dynamic resource allocation methodologies.

1) *Dynamic Contention-Free Protocols:* Dynamic contention-free protocols proposed in literature are primarily TDMA based. Dynamic TDMA protocols are primarily based on reallocation of slots or adapting the number of slots, as a function of the number of active nodes and their traffic

intensity. For example, in the Unifying Dynamic Distributed Multichannel TDMA Slot Assignment protocol (USAP), nodes with data to send first observe and then select vacant slots in the TDMA frame to transmit their data [24]. USAP and similar protocols require the exchange of considerable control information between the nodes. Additionally, the presence of a large number of unassigned slots leads to higher delays when the load is low. Many enhancements to the basic idea of USAP have been proposed to enhance its performance [25], [26]. These enhancements allow the frame length and frame cycle to change dynamically, based on the network condition. Although these protocols improve the average channel utilization, it is still low and the control overhead is significant due to the frequent information exchange between neighboring nodes. Other extensions to TDMA include protocols that allow nodes to dynamically schedule their transmissions based on the node density and bandwidth requirement [27], reserve TDMA slots based on routing information [28], and use deadlines associated with messages to determine channel access [29], [30].

2) *M2M Communications and Contention-Free Protocols:* The main advantage of contention-free protocols is their better channel utilization at high loads. However, the utilization drops at low loads, the protocols are difficult to adapt when the number of nodes in the network varies, and usually have strict requirements on the hardware. In the context of M2M communications, the drawbacks outweigh the advantages and it is challenging for contention-free protocols to provide the flexibility and scalability that is desired in these scenarios.

Contention-free protocols that dynamically adapt their operation as per the network conditions are better suited for networks with variability (in terms of traffic and active nodes). However the facilitation of dynamic operation requires additional overheads which limit the overall improvement. For example, in dynamic TDMA protocols such as Five Phase Reservation Protocol (FPRP) [31], Node Activation Multiple Access (NAMA) [32], and their derivatives, collisions may occur during certain stages of their operation, limiting their applicability in scenarios with high node density. In addition, TDMA type protocols have stringent time synchronization requirements which are difficult to implement, and result in extra bandwidth and energy consumption. Finally, the average packet delays with these protocols is considerably higher (particularly at low loads), which is a concern for delay sensitive applications.

CDMA based protocols are unsuitable for low cost M2M devices primarily due to their complexity. CDMA based communication requires strict power control in order to address the near-far problem at the receiver due to multiple access interference. The need for power control imposes computational and hardware requirements that increase the overall system cost. In addition, CDMA requires computationally expensive operations for encoding and decoding messages, making it less appropriate for networks where devices lack special hardware and that have limited computing power.

Compared to TDMA and CDMA, FDMA is less suitable for operation with low cost devices. The first reason for this is FDMA capable nodes require additional circuitry to

communicate and switch between different radio channels. The complicated band pass filters required for this operation are relatively expensive. Another disadvantage of FDMA that limits its practical use is the rather strict linearity requirement on the medium.

### C. Hybrid MAC Protocols

Contention-based protocols adapt easily to changing network scenarios and are better suited for networks with low loads. On the other hand, contention-free protocols eliminate collisions and have better channel utilization at higher loads. To harness the advantages of both classes of protocols, hybrid protocols have been proposed that combine aspects of contention-based and contention-free protocols.

1) *Hybrid TDMA/FDMA/CDMA Protocols with Contention*: Hybrid MAC protocols proposed in literature usually combine elements of CSMA with TDMA, FDMA and CDMA. Protocols that combine TDMA and CSMA such as [33], [34] behave as CSMA at low contention levels and switch to TDMA type operation at high contention levels. Protocols such as the hybrid MAC (HyMAC) protocol proposed in [35] combine CSMA with TDMA and FDMA where nodes are assigned a frequency as well as a time slot to transmit data once they successfully send a bandwidth request using contention based transmission. Similar protocols where CSMA based bandwidth requests are used to determine the allocation of slots and codes have also been proposed [36], [37], [38].

2) *M2M Communications and Hybrid Protocols*: Hybrid protocols address some of the performance issues that arise with contention-based and contention-free protocols. Protocols that switch between random access based operation at low loads and scheduled access at high loads avoid the degraded throughput and collisions of random access protocols at high loads and low channel utilization of scheduled access at low loads. Consequently, hybrid protocols are a promising approach for designing MAC protocols for M2M communications.

The main drawback of hybrid protocols that have been proposed in the context of wireless ad hoc and sensor networks is their scalability. Many scenarios with M2M communications have node *densities* that are an order of magnitude (and more) greater than currently deployed wireless networks. At such high densities, the incidence of collisions during the random access based slot/code/frequency reservation stage of hybrid protocols becomes the bottleneck that prevents the network from achieving a high utilization.

Another limiting factor of hybrid protocols for ad hoc and sensor networks when applied to M2M networks is the overhead associated with reconfiguring the system settings in order to accommodate varying traffic conditions and number of active nodes. This limitation is most prominent in the case of TDMA based protocols where the frame length needs to be dynamically adjusted. Such dynamic tuning of frame lengths usually results in the waste of some slots and also requires control overhead, in addition to the need for synchronization among nodes.

Hybrid protocols based on FDMA and CDMA have better scalability than pure FDMA and CDMA. However, the

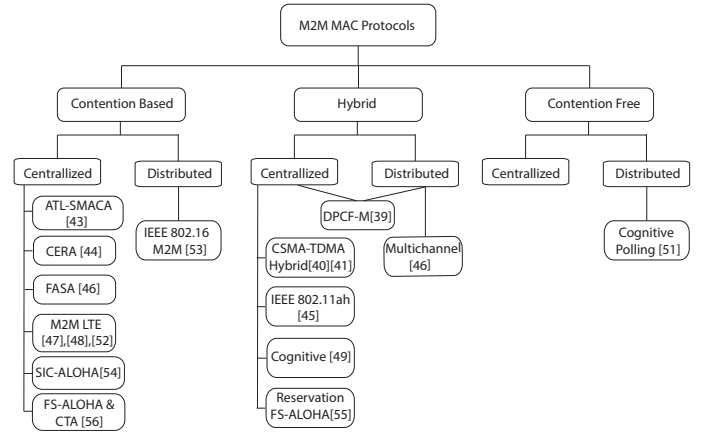

Fig. 1. Taxonomy of M2M MAC protocols.

drawback of FDMA in terms of the requirement for expensive hardware and that of CDMA for complex operation and the need for power control still remains. Consequently, TDMA based hybrid protocols are the most promising of the hybrid protocols in the context of M2M communications.

## IV. MAC PROTOCOLS SPECIFIC TO M2M COMMUNICATIONS

In order to address the unique requirements of M2M communications, an intuitive approach is to develop MAC protocols specific to these environments. Recent research along these lines has proposed various protocols and this section reviews these protocols. A taxonomy of the protocols surveyed in this section is shown in Figure 1 and their comparison in terms of the M2M communication requirements listed in Section II is given in Table I.

### A. DPCF-M

A hybrid MAC protocol for M2M communications named DPCF-M (Distributed Point Coordination Function-M) was proposed in [39] to address energy constrained M2M communication. This protocol uses a hybrid of CSMA/CA and Point Coordination Function (PCF) of IEEE 802.11 for channel access. DPCF-M is designed for scenarios where there are two types of devices: local M2M nodes and gateway-capable nodes. Gateway-capable nodes are equipped with a short range interface for local communication and a cellular radio interface, whereas M2M nodes are equipped with only a low-power short-range radio. For local communication among neighboring nodes, the protocol uses CSMA/CA non beacon mode of the IEEE 802.15.4. However when a M2M node needs to contact an external server through the cellular network, it uses one of the gateway-capable nodes to send the data.

The operation of DPCF-M protocol is shown in Fig. 2. In this figure, device 1 is a M2M node and wishes to send data to an external server through the cellular link. Device 1 first obtains access to the local channel using CSMA/CA, and then sends a Request for Gateway (RFG) packet to its

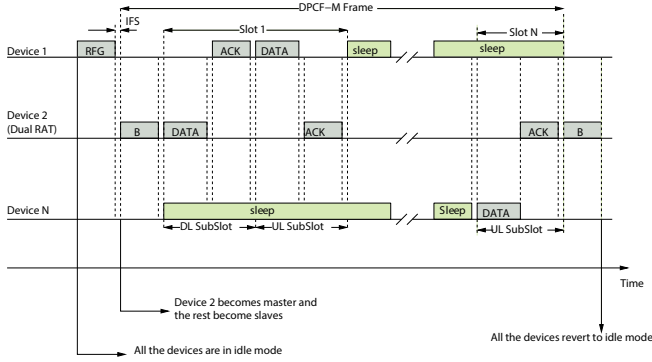

Fig. 2. DPCF-M protocol frame structure [39].

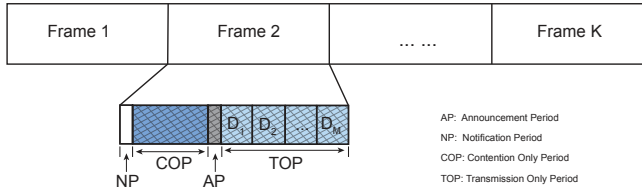

Fig. 3. Frame structure for the contention-TDMA hybrid MAC protocol from [40].

selected gateway (device 2, which is a gateway-capable node). On receiving the RFG packet, device 2 assumes the role of a master and starts a temporary cluster by periodically transmitting a beacon during the existence of the cluster. Devices that overhear this beacon (say devices  $1, 3 \dots, N$ ) enter into the slave mode. Devices in slave mode suspend their CSMA/CA based operation and transmit only when permitted by the master. The time between two successive beacons is divided into a number of slots and each slot is further divided into uplink and downlink sub-slots. Devices in the cluster are assigned individual slots by the master thereby allowing them to sleep at other times, and nodes without data to send stay silent in their slots. In Fig. 2, it is assumed that both device 1 and device  $N$  have data to transmit to the gateway and they are assigned slots 1 and  $N$ , respectively. The DPCF-M protocol outperforms CSMA/CA based protocols in terms of the throughput and energy efficiency. However, the energy savings come with additional hardware costs for gateway nodes that require two radios. Also, the protocol does not eliminate the collisions that result during local communication using CSMA/CA.

### B. Scalable Hybrid MAC

A CSMA-TDMA hybrid MAC protocol for M2M communications is proposed in [40]. The protocol divides time in frames and each frame consists of four parts: notification period (NP), contention only period (COP), announcement period (AP), and transmission only period (TOP), as shown in Fig. 3. Each frame starts with a NP where the base station (BS) announces the start of the COP to all nodes. During the COP, nodes with data use  $p$ -persistent CSMA to send transmission requests to the BS. Successful nodes are allocated slots to transmit data in the TOP and the nodes are informed of their slots during the

AP. The length of the COP may vary from frame to frame. An optimization problem is solved by the BS to determine the optimum COP length and the number of devices that are allowed to transmit in the TOP. The length of the contention period as well as the optimum contention probability for the  $p$ -persistent CSMA is communicated to all nodes by the BS during the NP. The protocol in [40] is extended in [41] with the addition of quality of service provisioning and fairness by allowing nodes to choose their contention probabilities according to their priority and observed throughput. While the protocols in [40], [41] incur additional delays and energy consumption due to the time required for the COP and the need for contention, they provide a tradeoff between the performance of  $p$ -persistent CSMA and TDMA.

### C. Adaptive Multichannel Protocol for Large-Scale M2M

A contention-FDMA hybrid MAC protocol based on the use of a common control channel is proposed in [42] for use in large scale M2M networks. In the proposed protocol, the available bandwidth is split into a number of channels, with one of them used as the control channel. Also, time is divided into intervals of fixed length and each interval is further divided into three phases: estimation, negotiation and data transmission. The estimation phase consists of a number of time slots in which nodes transmit busy tones on the common control channel if they have data to send or if they hear a busy tone from other nodes, with decreasing probability in each time slot. Based on the total number of busy tones sent and heard, a methodology for statistically estimating the number of active nodes is presented. The negotiation phase consists of a number of slots, and nodes transmit data transmission requests (in the control channel) in each slot with a given probability. Nodes that successfully receive request messages reply back confirming the channel to be used for the data transfer. The length of the negotiation phase as well as the access probability are determined from the estimated number of active nodes. Nodes that have successfully reserved a channel with their receiver in the negotiation phase proceed to transmit their data in the data transmission phase. While the protocol performs well in terms of channel utilization, it adds an extra overhead due to the estimation phase. Also, if all nodes are not in the range of each other, estimates of the number of active nodes and thus the parameters for the negotiation phase may not be the same at all nodes.

### D. Adaptive Traffic Load Slotted MACA

For M2M networks with nodes incapable of carrier sensing, an extension of the slotted MACA protocol called Adaptive Traffic Load slotted MACA (ATL S-MACA) protocol has been proposed in [43]. The ATL S-MACA protocol slightly modifies the basic RTS-CTS-DATA-ACK based scheme of MACA and RTS contention is adaptively controlled based on an estimate of the traffic load. The basic idea behind ATL S-MACA is the observation that slotted MACA reaches its maximum throughput at some value of traffic load  $G_{opt}$  and then decreases rapidly. The BS in ATL S-MACA thus estimates the traffic load  $G$  and then assigns a probability of



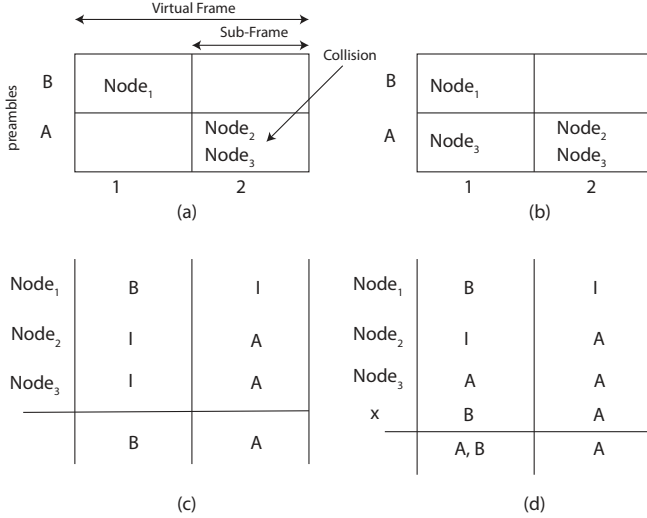

Fig. 4. Code expanded random access [44]: (a) Current random access in LTE, (b) Code expanded random access, (c) Current LTE random access codewords, with collision for nodes 2 and 3, (d) Code expanded codewords, with phantom codeword in last row. *I* denotes a node is idle.

$G_{opt}/G$  to each node for RTS contention. Thus the offered traffic load is kept constant at  $G_{opt}$ . ATL S-MACA suffers from increased collisions since all nodes are allowed to send RTS packets at the beginning of a slot.

#### E. Code Expanded Random Access

The code expanded random access (CERA) mechanism is proposed in [44] and is based on a modification of the dynamic Random Access Channel (RACH) resource allocation used in Long Term Evolution (LTE). The objective of the proposed protocol is to provide support for a larger number of devices as compared to LTE, without increasing the resource requirements. In LTE, random access is performed by nodes by selecting one of the available orthogonal preambles and then sending it over a randomly selected sub-frame. For example, as shown in Fig. 4 (a), when a node wants to perform random access, it does so by choosing one of the available preambles (denoted here by *A* and *B*) and then selecting a random access sub-frame (denoted here by 1 and 2) to transmit the chosen preamble. In Fig. 4 (a), the first node (or user equipment (UE) in LTE parlance), UE<sub>1</sub>, selects preamble *B* and transmits it in sub-frame 1. When two or more nodes select the same preamble and same sub-frame to transmit the connection request, there is a collision, as denoted by the collision of UE<sub>2</sub> and UE<sub>3</sub> in the second sub-frame. Figure 4 (c) shows the preambles as received the BS in each random access sub-frame, in order to discern between the nodes sending requests.

In the modified access procedure presented in [44], a fixed number of sub-frames are grouped into a virtual frame. For example, in Fig. 4(b) two sub-frames constitute one virtual frame and there are three possible preambles that can be sent: *A*, *B* and Idle (*I*). Instead of sending a preamble in a single sub-frame as in conventional LTE, nodes in the proposed scheme send a preamble in each of the sub-frames in a virtual frame. The sequence of preambles transmitted by a node in

a virtual frame constitutes its codeword and the BS identifies a node based on its codeword. This increases the number of contention resources and reduces the likelihood of collision (a collision occurs when two or more nodes select the same codeword). The protocol's operation is shown in Fig. 4 (b) and (d). In this example, UE<sub>1</sub>, UE<sub>2</sub> and UE<sub>3</sub>'s codewords consist of two preambles each (*BI*, *IA* and *AA*, respectively) distributed over two sub-frames. Thus when the BS receives preambles *A* and *B* in the first sub-frame and preamble *A* in the second sub-frame, it lists all possible permutations of the codewords that could have been sent (*AA*, *BA*, *AI*, *IA*, *BI*) and assumes that all nodes with corresponding codewords have transmitted. Note that this leads to "phantom" codewords (*BA* and *AI*), indicated by an "x" in Fig. 4 (d), which causes the BS to incorrectly add nodes that have not transmitted any codewords. However, the likelihood of such phantom codewords reduces when the traffic load is high.

#### F. Enhancement of IEEE 802.11ah for M2M Communications

In addition to the ability to offload cellular traffic, the IEEE 802.11ah protocol is also expected to have the capability to support M2M communication. To facilitate the transmission of M2M traffic, IEEE 802.11ah uses beacons to divide time into frames and each frame is further divided into two sections: Restricted Access Window (RAW) and offload traffic. Each RAW is divided into slots and a slot may either be allocated to a device by the AP or may be randomly selected by a device. Within each slot selected by a device, a binary exponential backoff based access method is used by the devices to send a polling frame to request channel access. The authors of [45] address the problem of estimating the required length of the RAW in order to facilitate the efficient channel access by the devices. The enhancement proposed by the authors divides the RAW into two sections: RAW uplink (RAW-UL) and RAW downlink (RAW-DL) and the focus is on the uplink. To determine the RAW-UL size, the AP first determines the number devices wishing to transmit. This estimate is obtained by the AP by using the probability of successful transmissions in the last frame. The number of slots in the RAW-UL (and thus the size of the RAW-UL) is taken as a linear function of the estimated number of active nodes. Compared to the original IEEE 802.11ah protocol, the proposed enhancement achieves a higher probability of successful transmission.

#### G. Fast Adaptive Slotted ALOHA

The Fast Adaptive Slotted ALOHA (FASA) protocol is proposed in [46] for random access in event driven M2M communications. In FASA, the network status in terms of the number of backlogged devices,  $N_t$ , is estimated by using drift analysis on the access results of the past slots. Using this network information, each node in the network is then assigned  $1/N_t$  as its transmission probability in each slot. This approach is similar to that of ATL S-MACA in [43]. The BS is responsible for estimating the number of backlogged nodes and communicating the transmission probability to backlogged devices.

## H. M2M Communications Using Cellular Networks

The MAC layer design for M2M communication in LTE Advanced (LTE-A) is considered in [47]. The authors argue that the overhead associated with the signaling required for the radio resource control (RRC) mechanism of LTE is prohibitive in the case of M2M communications where devices may have very little data to send. To make the channel access mechanism more efficient, the authors present a policy where backlogged nodes first send an access request to the BS using a preamble. On receiving the preamble, the BS allocates uplink resources to the node to send the RRC setup request. However, instead of sending a RRC setup request as in LTE-A, the nodes directly send data in the form of a MAC protocol data unit (PDU). The BS is modified to recognize the MAC PDU which may contain the node identity and security information. The authors also propose an enhancement where the MAC protocol is further simplified by allowing nodes to directly send the data in encoded format along with a special preamble. The proposed simplifications to the MAC layer in LTE-A improve the efficiency and avoid unnecessary control overhead. However, the possibility of collisions and contention resolution is not discussed or considered.

The overload problem during random access of Physical Random Access Channel (PRACH) in LTE-A due to simultaneous transmissions by a large number of M2M devices is addressed in [48]. Six possible solutions for the PRACH overload problem have been proposed by the Third Generation Partnership Project (3GPP). However, these methods do not address the issue of PRACH overload detection and notification. Thus [48] proposes a self-optimizing overload control (SOOC) mechanism which dynamically detects congestion in a PRACH channel. In the proposed overload detection mechanism, M2M devices count the number of times they do not receive a response from the BS to their random access requests. This information is transmitted by the M2M devices to the BS as a PRACH overload indicator. To adapt to the overload, the BS then increases the number of slots for PRACH depending on the value of the received PRACH overload indicator. The increase or decrease of the PRACH random access slots may be done in the frequency domain, time domain, or both. At the end of each random access cycle, the BS first estimates the collision probability,  $p_c$ , in the cell or sector using the PRACH overload indicators. It then uses this  $p_c$  to calculate the number of random access requests per second,  $B$ , using  $B = -L \ln(1 - p_c)$  where  $L$  is the current number of random access resources (i.e. slots) per second. Then, for the desired collision probability,  $p'_c$ , and the current estimate of  $B$ , the BS calculates required number of random access resources per second,  $L'$ , using  $B = L' \ln(1 - p'_c)$ . The BS then determines the additional random access resources required as:  $L' - L$ .

## I. Cognitive Radio based M2M Communications

A MAC protocol for M2M communications that uses cognitive radio technology at the physical layer is proposed in [49]. The methodology proposed in [49] combines the packet reservation multiple access (PRMA) protocol of [50] with a

cognitive radio physical layer that uses television (TV) white spaces for communication between the M2M devices and their gateways. The underlying TV channel is divided in slots of fixed length and time division duplexing is used to separate the uplink and downlink transmissions. All uplink slots are initially available for contention and each M2M device may contend for an available slot with some probability  $p$ . The gateway responds to each correctly received contention request with an ACK in the downlink phase, and this also implies a reservation of the same slot in subsequent frames. A backoff mechanism is used by the devices in case of collisions. While the proposed protocol addresses the question of spectrum scarcity, its performance is limited by the increased levels of collisions as the node density increases.

A polling based MAC protocol that may be used for M2M communications is proposed in [51] for use in orthogonal frequency division multiple access (OFDMA) based wireless networks. The proposed protocol uses cognitive radio techniques and the M2M devices are considered secondary users. The authors consider the case where network access is frame based and the BS (e.g. in WiMAX or LTE) broadcasts the information regarding the resource allocation to the primary users (in terms of subchannels and time slots) in each frame. In the proposed protocol, M2M devices listen to these broadcasts and use the unoccupied resources for communicating among themselves. The main advantage of the proposed scheme is that no spectrum scanning is required to find unused resources. While communicating in the unused subchannels and slots, the M2M devices use token passing based polling to determine the channel access. The proposed protocol does not provide any guarantees on the delays and throughput experienced by the M2M devices. In addition, the token passing strategy is inefficient for M2M devices with bursty traffic.

## V. PERFORMANCE STUDIES

In addition to developing or enhancing MAC protocols for M2M communications, the performance of existing technologies for M2M communications has also been reported in literature.

### A. Evaluation of Preamble Division in LTE

In the context of LTE, the impact of the use of preambles for resource allocation is discussed in [52]. The objective of [52] is to evaluate the impact of the division of preambles for channel access in LTE among human-to-human (H2H) and M2M traffic. The authors consider two methods for dividing the preambles. In the first method, the preambles are divided into two separate groups for H2H and M2M traffic. In the second method, some preambles are reserved for H2H traffic and the remaining are shared by both H2H and M2M communications. It is shown that, in general, if the number of shared resources in the second method is greater than the number of fixed resources for M2M traffic in the first method, then the performance seen by M2M devices in both methods is comparable. Also, there is a boundary in terms of the offered load, below which the second method performs better, and above which its performance degrades to a large extent. Thus



TABLE I  
COMPARISON OF MAC PROTOCOLS SPECIFIC TO M2M COMMUNICATION

Protocol	Throughput/ Utilization	Scalability	Energy efficiency	Latency	Cost	Burst handling
DPCF-M [39]	Moderate	Moderate	Moderate	Moderate	Low	Yes
CSMA-TDMA Hybrid [40], [41]	Moderate	Moderate	Moderate	Low	Low	No
Contention-FDMA Hybrid [42]	Moderate	Moderate	Low	High	Low	Yes
ATL-SMACA [43]	Low	Low	Low	High	Low	No
CERA [44]	High	Moderate	Moderate	Low	High	Yes
IEEE 802.11ah [45]	High	High	Moderate	Moderate	Low	No
FASA [46]	Low	Low	Low	High	Low	No
M2M LTE [47]	Moderate	Low	Moderate	Moderate	High	No
M2M LTE [48]	High	Moderate	Moderate	Moderate	High	Yes
Cognitive [49]	High	Moderate	Moderate	Moderate	High	Yes
Cognitive polling [51]	Moderate	Low	High	High	High	No

dynamically allocating preambles to M2M traffic achieves the best performance.

### B. Efficiency and Delay Analysis of IEEE 802.16

The slot efficiency and mean access delay for M2M communications using IEEE 802.16 is evaluated in [53]. A mathematical model is developed to evaluate the performance of slotted ALOHA and the extended backoff mechanism (EB) used in the IEEE 802.16 protocol. The developed analytic models evaluate the efficiency and access delays as a function of the traffic arrival rate. The proposed models can be used to select the appropriate ranging parameters to enhance the efficiency of limited ranging resources and reduce network access delay.

### C. Analysis of SIC Frame-Slotted ALOHA

The performance of frame-slotted ALOHA (FSA) with successive interference cancellation (SIC) is evaluated and compared with traditional FSA in [54]. In traditional FSA, time is divided into frames and each frame consists of a number of slots. In each frame, a node randomly chooses a subset  $K$  (with  $K \geq 1$ ) of the slots to transmit. In each of the chosen slots, a node transmits a replica of the same data packet. Slots in which only one node transmits are successful and nodes without a successful transmission in a given frame try again in the next frame. Under the proposed FSA with SIC (SIC-FSA) protocol, the MAC header of each replica contains a pointer to the slots in which the other  $K - 1$  replicas are transmitted. Thus if the BS (or coordinator node in FSA literature) is able to receive any one of the replicas successfully, it can determine the slot locations of the other replicas. If any of those slots has a collision, the coordinator can subtract the received signal of the successful slot from the signal in the slot with collision to decode data packets that were initially lost due to collision (i.e. the coordinator performs SIC). The newly decoded data packets also contain the information about their  $K - 1$  replicas. Thus this process is iterated until the coordinator is no longer able to decode any more data packets. The authors of [54] evaluate the performance of the traditional FSA and SIC-FSA and obtain

the optimal value of  $K$  that minimizes the average delay and energy consumption. It is shown that the optimal value of  $K$  is dependent on the ratio of the number of slots in a frame and the number of M2M devices reporting to the coordinator.

### D. Performance Evaluation of Reservation Frame-Slotted ALOHA

Reservation Frame Slotted ALOHA (RFSA) is an evolution of FSA in which a node gets to reserve a slot for data transmission in each frame once it successfully accesses the channel for the first time. The node may continue its reservation of the slot until its data queue is empty. The authors of [55] evaluate the energy and delay performance of RFSA in a M2M network with periodic bursts of traffic from a large number of nodes. The results show that RFSA outperforms FSA in terms of average delay, throughput and energy consumption.

1) *Comparison of Contention Resolutions Algorithms:* The energy and delay analysis of two contention based protocols with application to M2M networks based on low power devices is performed in [56]. The first protocol is FSA while the second protocol considered is the contention tree algorithm (CTA). In the CTA, each node randomly selects a slot in a frame to transmit. If there a collision in any slot, say slot  $i$ , a new frame is assigned to all the devices that caused the collision in slot  $i$ . Thus if a frame has collisions in  $k$  slots, it would be followed by  $k$  additional frames, leading to the formation of a tree whose expansion stops either when all slots in a frame are empty or successful. Mathematical models are formulated in [56] to evaluate the two protocols in terms of their energy and delay, and to determine the optimal frame length for maximizing the energy efficiency and minimizing the delay. The authors show that the performance of CTA and FSA is almost identical when the number of devices is small and CTA performs slightly better when the number of devices increases.

## VI. STANDARDIZATION AND FUTURE RESEARCH

The emerging explosion of M2M traffic and the revenue it is expected to fetch, has initiated a number of activities to develop standards that govern various aspects of M2M

data transmissions. In this section we present an overview of these standardization efforts. In addition, we present a list of research issues that still remain open.

#### A. Standards for M2M Communications

The primary focus of standardization bodies has been to support M2M communication in existing networks. Current efforts are mainly focused at developing specifications that enable basic M2M communications. As M2M applications and devices continue to evolve, subsequent phases of standardization efforts are expected to develop advanced specifications.

3GPP and IEEE 802.16 (WiMax) mainly address the problem of M2M devices connecting to a base station (BS). In IEEE 802.16p, IEEE 802.16's M2M Task Group was initiated to address enhancements in the existing standard to support M2M communications [4]. Grouping of BS and M2M devices in a M2M group zone is suggested as one of the solutions to tackle the increased number of devices. In addition, IEEE 802.16p is looking at scalability, power issues, and device authentication. The 3GPP Release 13 standard addresses M2M related congestion control, low power operation, admission control, overload control, identifiers, addressing, subscription control and security [2]. The solutions proposed in 3GPP include grouping of M2M devices based on their priorities and location, and refusing or delaying access when the network is overloaded. Future topics to be considered by IEEE 802.16p include M2M gateways, co-operative M2M networks, and other advanced M2M features. Similarly, future 3GPP standards are expected to further enhance M2M group operation, develop M2M gateways, and provide advanced services and optimizations.

The IEEE 802.11ah Working Group is currently in the process of developing standards for M2M communication in the sub-1GHz band. This standard specifically addresses the problems of scalability, large number of nodes per AP, and long range transmissions by energy constrained M2M devices. The large number of nodes are accommodated by using a hierarchical method which uses a unique Association Identifier (AID) to classify the nodes at different levels. The protocol achieves energy savings by deactivating the M2M nodes during periods where a node does not have any traffic. The standard specifically addresses performance issues with small data transmissions from sensors that generate high overheads and low performance in wireless networks [57].

Other standardization bodies that are active in the area of M2M communications include IEEE 802.15.4, European Telecommunications Standards Institute (ETSI), Telecommunications Industry Association (TIA), and OneM2M. The IEEE 802.15.4 standard addresses the PHY and MAC layer for low rate wireless personal area networks. Its MAC layer is based on CSMA/CA. Also, nodes may use a time slotted channel hopping mechanism to shuffle between the available channels periodically in order to tackle the problem of interference from co-located wireless systems [58]. The M2M communications related standardization activities of ETSI mainly focus on the service middleware layer. The ETSI standards take an end-to-end view to define a set of

standardized service capabilities that are required to provide the functionalities shared by various M2M applications [59]. The standardization activities of TIA focus on developing interface standards for the exchange of information between diverse M2M devices and applications. The proposed standard develops a smart device communications (SDC) layer that allows communication over multiple transport protocols [60]. The objective of the oneM2M partnership program is to bring together a number of telecommunications standardization bodies and organizations from M2M-related businesses to develop standards for M2M communications. OneM2M aims to standardize the technical specifications for common M2M service layers for communication and management of heterogeneous M2M devices for diverse applications. Currently, their focus is on defining requirements, security solutions, and evaluating architectures for use in M2M communications [61].

#### B. Future Research Directions

As highlighted in Section IV, recent research has started to develop MAC protocols that are specifically targeted for M2M communications. However, a number of open issues remain to be solved before the MAC layer requirements of M2M communications are fully satisfied. This section presents an overview of the research that is required in this direction.

1) *Scalability and Large Network Sizes:* Scalability of the MAC protocol as the number of nodes in the network increases by an order of magnitude or more, remains the fundamental open problem at the MAC layer. The developed MAC protocols should have the capability to handle simultaneous channel access requests or transmission attempts by extremely large number of devices. In addition to MAC layer enhancements, this problem may also be alleviated by the use of smarter physical layer signal processing techniques that facilitate multiple access communications.

2) *Exploiting M2M Traffic Characteristics:* Applications with M2M communications generate traffic with diverse characteristics. For example, traffic may be periodic or bursty, may have strict timing requirements or be elastic, and may have different peak-to-average rate requirements. Appropriately designed MAC layer schedulers or resource allocation mechanisms are thus required in order to exploit the presence of flows with diverse requirements to enable a better utilization of the available resources.

3) *Support for Extremely Low Power Operation:* Sources for M2M traffic such as sensors may have limited, or in some cases, no access to power. For such devices, further work needs to be done to develop MAC protocols that can support low power communications such as on-demand query-initiated transmissions, coordinate sleep-wake schedules across nodes, and provide power control. Similar issues have been considered in the context of traditional wireless sensor networks. However, integrating support for low power communications into massively scalable MAC protocols remains an open problem.

4) *Priority Access:* Existing MAC protocols need to be extended to provide adequate support for prioritized access to relevant applications. Priority access is needed, for example,

by applications that generate and communicate alarms in response to specific conditions. Support for priority access may be provided in a number of ways such as supporting differentiated bandwidth requests, resource reservation and preemption for priority services, admission control etc.

5) *Quality of Service Support*: M2M communications are expected to be employed for various mission critical applications where there are strict requirements on the timely and correct delivery of data. Emerging MAC protocols for M2M communications have to provide the desired guarantees for the delay, throughput and loss requirements (to name a few) of the applications. Integrating such quality of service support in dense networks remains an open issue.

6) *Support for Heterogeneous Transceivers*: Most existing MAC protocols are designed for use with a specific transceiver hardware and usually assume that all nodes (for example, subscriber stations, sensor nodes) in the network are homogeneous in terms of their transceivers. In M2M networks with diverse hardware types, such an assumption is too restrictive and needs to be generalized. Thus MAC protocols need to be developed for scenarios where nodes have transceivers with non-homogeneous capabilities and constraints.

## VII. CONCLUSIONS

The future evolution of the Internet-of-Things relies on the development of network support at all layers for supporting M2M communications. This paper presented an overview of the MAC layer issues in M2M communications. The paper also presented a survey of existing MAC layer solutions for wireless networks and evaluated them in the context of M2M communications. MAC protocols that have been specifically proposed for M2M communications were reviewed. Finally, current standardization efforts as well as open research issues were discussed.

## REFERENCES

- [1] T. Taleb and A. Kunz, "Machine type communications in 3GPP networks: potential, challenges, and solutions," *IEEE Communications Magazine*, vol. 50, no. 3, pp. 178–184, 2012.
- [2] 3GPP, "Service requirements for machine-type communications," *3GPP TS 22.368 V13.0.0*, 2014.
- [3] 3GPP, "System improvement for machine-type communications," *3GPP TR 23.888 V11.0.0*, 2012.
- [4] IEEE, "802.16p-2012 - IEEE standard for air interface for broadband wireless access systems—Amendment 1: Enhancements to support machine-to-machine applications," *IEEE Standards*, pp. 1–82, 2012.
- [5] J. Malmödin, Å. Moberg, D. Lundén, G. Finnveden and N. Göran and N. Lövehagen, "Greenhouse gas emissions and operational electricity use in the ICT and entertainment & media sectors," *Journal of Industrial Ecology*, vol. 14, no. 5, pp. 770–790, 2010.
- [6] F. De Rango, A. Perrotta, and S. Ombres, "A energy evaluation of E-TDMA vs IEEE 802.11 in wireless ad hoc networks," in *Proceedings of SPECTS*, pp. 273–279, 2010.
- [7] N. Abramson, "THE ALOHA SYSTEM: another alternative for computer communications," in *Proceedings of the AFIPS Conference*, pp. 281–285, 1970.
- [8] L. G. Roberts, "ALOHA packet system with and without slots and capture," *ACM SIGCOMM Computer Communication Review*, vol. 5, no. 2, pp. 28–42, 1975.
- [9] L. Kleinrock and F. Tobagi, "Packet switching in radio channels: Part I—Carrier sense multiple-access modes and their throughput-delay characteristics," *IEEE Transactions on Communications*, vol. 23, no. 12, pp. 1400–1416, 1975.
- [10] F. Tobagi and L. Kleinrock, "Packet switching in radio channels: part II—The hidden terminal problem in carrier sense multiple-access and the busy-tone solution," *IEEE Transactions on Communications*, vol. 23, no. 12, pp. 1417–1433, 1975.
- [11] J. Deng and Z. J. Haas, "Dual busy tone multiple access (DBTMA): A new medium access control for packet radio networks," in *Proceedings of IEEE ICUPC*, vol. 2, pp. 973–977, IEEE, 1998.
- [12] P. Karn, "MACA-A new channel access method for packet radio," in *Proceedings of ARRL/CRRL Amateur Radio Computer Networking Conference*, pp. 134–140, 1990.
- [13] IEEE, "Wireless LAN Medium Access Control (MAC) and Physical Layer (PHY) Specifications," *IEEE Standard 802.11*, 1997.
- [14] G. Bianchi, "Performance analysis of the IEEE 802.11 distributed coordination function," *IEEE Journal on Selected Areas in Communications*, vol. 18, no. 3, pp. 535–547, 2000.
- [15] O. Tickoo and B. Sikdar, "Modeling queueing and channel access delay in unsaturated IEEE 802.11 random access MAC based wireless networks," *IEEE/ACM Transactions on Networking*, vol. 16, no. 4, pp. 878–891, 2008.
- [16] C. Crespo, J. Alonso-Zarate, L. Alonso, and C. Verikoukis, "Distributed point coordination function for wireless ad hoc networks," in *Proceedings of IEEE VTC (Spring)*, pp. 1–5, 2009.
- [17] F. Cali, M. Conti, and E. Gregori, "Dynamic tuning of the IEEE 802.11 protocol to achieve a theoretical throughput limit," *IEEE/ACM Transactions on Networking*, vol. 8, no. 6, pp. 785–799, 2000.
- [18] F. Ye, S. Yi, and B. Sikdar, "Improving spatial reuse of IEEE 802.11 based ad hoc networks," in *Proceedings of IEEE GLOBECOM*, vol. 2, pp. 1013–1017, 2003.
- [19] N.-O. Song, B.-J. Kwak, J. Song, and M. Miller, "Enhancement of IEEE 802.11 distributed coordination function with exponential increase exponential decrease backoff algorithm," in *Proceedings of IEEE VTC (Spring)*, vol. 4, pp. 2775–2778, 2003.
- [20] R. Rom and M. Sidi, *Multiple Access Protocols: Performance and Analysis*, Springer Verlag, New York, 1990.
- [21] W. Stallings, *Data and Computer Communications*, Macmillan Inc., New York, 1985.
- [22] R. Pickholtz, D. Schilling and L. Millstein, "Theory of spread-spectrum communications- A tutorial," *IEEE Transactions on Communications*, vol. 30, no. 5, pp. 855–884, May 1982.
- [23] A. Viterbi, *CDMA: Principles of Spread Spectrum Communications*, Addison-Wesley, Reading, MA, 1995.
- [24] C. D. Young, "USAP: A unifying dynamic distributed multichannel TDMA slot assignment protocol," in *Proceedings of IEEE MILCOM*, vol. 1, pp. 235–239, 1996.
- [25] C. D. Young, "USAP multiple access: Dynamic resource allocation for mobile multihop multichannel wireless networking," in *Proceedings of IEEE MILCOM*, vol. 1, pp. 271–275, 1999.
- [26] A. Kanzaki, T. Uemukai, T. Hara, and S. Nishio, "Dynamic TDMA slot assignment in ad hoc networks," in *Proceedings of IEEE AINA*, pp. 330–335, 2003.
- [27] C. Zhu and M. S. Corson, "An evolutionary-TDMA scheduling protocol (E-TDMA) for mobile ad hoc networks," *Technical Report CSHCN TR 98-14*, University of Maryland, College Park, 1998.
- [28] K. Arisha, M. Youssef, and M. Younis, "Energy-aware TDMA-based MAC for sensor networks," in *Proceedings of IEEE IMPACCT*, pp. 21–40, 2002.
- [29] M. Caccamo, L. Y. Zhang, L. Sha, and G. Buttazzo, "An implicit prioritized access protocol for wireless sensor networks," in *Proceedings of IEEE RTSS*, pp. 39–48, 2002.
- [30] T. W. Carley, M. A. Ba, R. Barua, and D. B. Stewart, "Contention-free periodic message scheduler medium access control in wireless sensor/actuator networks," in *Proceedings of IEEE RTSS*, pp. 298–307, 2003.
- [31] C. Zhu and M. S. Corson, "A five-phase reservation protocol (FPRP) for mobile ad hoc networks," *Wireless networks*, vol. 7, no. 4, pp. 371–384, 2001.
- [32] L. Bao and J. Garcia-Luna-Aceves, "A new approach to channel access scheduling for ad hoc networks," *Proceedings of ACM MobiCom*, pp. 210–221, 2001.
- [33] I. Rhee, A. Warriar, M. Aia, J. Min, and M. L. Sichitiu, "Z-MAC: A hybrid MAC for wireless sensor networks," *IEEE/ACM Transactions on Networking*, vol. 16, no. 3, pp. 511–524, 2008.
- [34] R. Zhang, R. Ruby, J. Pan, L. Cai, and X. Shen, "A hybrid reservation/contention-based MAC for video streaming over wireless networks," *IEEE Journal on Selected Areas in Communications*, vol. 28, no. 3, pp. 389–398, 2010.

- [35] M. Salajegheh, H. Soroush, and A. Kalis, "HYMAC: Hybrid TDMA/FDMA medium access control protocol for wireless sensor networks," in *Proceedings of IEEE PIMRC*, pp. 1–5, 2007.
- [36] T. Shu and M. Krunz, "Energy-efficient power/rate control and scheduling in hybrid TDMA/CDMA wireless sensor networks," *Computer Networks*, vol. 53, no. 9, pp. 1395–1408, 2009.
- [37] M. Chatterjee and S. K. Das, "Performance evaluation of a request-TDMA/CDMA protocol for wireless networks," *Journal of Interconnection Networks*, vol. 2, no. 1, pp. 49–67, 2001.
- [38] A. Boukerche and T. Dash, "Performance evaluation of a generalized hybrid TDMA/CDMA protocol for wireless multimedia with QoS adaptations," *Computer communications*, vol. 28, no. 12, pp. 1468–1480, 2005.
- [39] F. Azquez-Gallego, J. Alonso-Zarate, I. Balboteo, and L. Alonso, "DPCF-M: A medium access control protocol for dense machine-to-machine area networks with dynamic gateways," in *Proceedings of IEEE SPAWC*, pp. 490–494, 2013.
- [40] Y. Liu, C. Yuen, J. Chen, and X. Cao, "A scalable hybrid MAC protocol for massive M2M networks," in *Proceedings of IEEE WCNC*, pp. 250–255, 2013.
- [41] Y. Liu, C. Yuen, X. Cao, N. U. Hassan, J. Chen, "Design of a Scalable Hybrid MAC Protocol for Heterogeneous M2M Networks," *IEEE Internet of Things Journal*, vol.1, no.1, pp. 99–111, 2014.
- [42] C. Y. Hsu, C. H. Yen, and C. T. Chou, "An adaptive multichannel protocol for large-scale machine-to-machine (M2M) networks," *Proc. IEEE IWCNC*, pp. 1223–1228, Italy, 2013.
- [43] G. Wang, X. Zhong, S. Mei, and J. Wang, "An adaptive medium access control mechanism for cellular based machine-to-machine (M2M) communication," *Proceedings of IEEE ICWITS*, pp. 1–4, 2010.
- [44] N. K. Pratas, H. Thomsen, C. Stefanovic, and P. Popovski, "Code-expanded random access for machine-type communications," in *Proceedings of IEEE GLOBECOM Workshops*, pp. 1681–1686, 2012.
- [45] C. W. Park, D. Hwang and T. J. Lee, "Enhancement of IEEE 802.11ah MAC for M2M Communications," *IEEE Communications Letters* vol.18, no. 7, 2014.
- [46] H. Wu, C. Zhu, R. J. La, X. Liu, and Y. Zhang, "Fast adaptive S-ALOHA scheme for event-driven machine-to-machine communications," in *Proceedings of IEEE VTC (Fall)*, pp. 1–5, 2012.
- [47] Y. Chen and W. Wang, "Machine-to-machine communication in LTE-A," in *Proceedings of IEEE VTC (Fall)*, pp. 1–4, 2010.
- [48] A. Lo, Y. W. Law, M. Jacobsson, and M. Kucharzak, "Enhanced LTE-advanced random-access mechanism for massive machine-to-machine (M2M) communications," in *Proceedings of WWRF*, pp. 1–5, 2011.
- [49] A. Aijaz and A. H. Aghvami, "A PRMA based MAC protocol for cognitive machine-to-machine communications," in *Proceedings of IEEE ICC*, pp. 2753–2758, 2013.
- [50] D. J. Goodman, R. A. Valenzuela, K. Gayliard, and B. Ramamurthi, "Packet reservation multiple access for local wireless communications," *IEEE Transactions on Communications*, vol. 37, no. 8, pp. 885–890, 1989.
- [51] D. Tarchi, R. Fantacci and D. Marabissi, "Proposal of a cognitive based MAC protocol for M2M environments," in *Proc. IEEE-PIMRC*, 2013, pp. 1609–1613.
- [52] K.-D. Lee, S. Kim, and B. Yi, "Throughput comparison of random access methods for M2M service over LTE networks," *Proceedings of IEEE GLOBECOM Workshops*, pp. 373–377, 2011.
- [53] S. Kim, J. Cha, S. Jung, C. Yoon, and K. Lim, "Performance evaluation of random access for M2M communication on IEEE 802.16 network," *Proceedings of IEEE ICACT*, pp. 278–283, 2012.
- [54] F. V. Gallego, M. Rietti, J. Bas, J. Alonso-Zarate and L. Alonso, "Performance Evaluation of Frame Slotted-ALOHA with Successive Interference Cancellation in Machine-to-Machine Networks," *Proc. 20th European Wireless Conf.*, May 2014, pp.1–6.
- [55] F. V. Gallego, J. Alonso-Zarate, A. M. Mandalari, O. Briante, A. Molinaro, G. Ruggeri "Performance Evaluation of Reservation Frame Slotted-ALOHA for Data Collection M2M Networks," *Proc. 20th European Wireless Conf.*, May 2014, pp.1–6.
- [56] F. V. Gallego, J. Alonso-Zarate and L. Alonso, "Energy and delay analysis of contention resolution mechanisms for machine-to-machine networks based on low-power WiFi," *Proc. IEEE ICC*, 2013, pp. 2235–2240.
- [57] T. Adame, A. Bel, B. Bellalta, J. Barcelo, J. Gonzalez and M. Oliver, "Capacity analysis of IEEE 802.11 ah WLANs for M2M communications," *Proc. 6th International Workshop on Multiple Access Communications*, Vilnius, Lithuania, December 2013.
- [58] IEEE, "IEEE standard for local and metropolitan area networks—Part 15.4: Low-rate wireless personal area networks (LR-WPANS) Amendment 1: MAC sublayer," *IEEE Standard 802.15.4e-2012*, pp. 1–225, 2012.
- [59] ETSI, "ETSI TS 102 690: Machine-to-machine communications (M2M); Functional architecture," *Technical Specifications*, 2013.
- [60] TIA, "TIA-4940 series: Smart device communications," *Technical Specifications*, 2013.
- [61] oneM2M, "OneM2M Requirements Technical Specification", *oneM2M Technical Specification*, TS-0002-V-0.6.2, November 2013.