

Planning, design and operation of surface water management systems

a case study

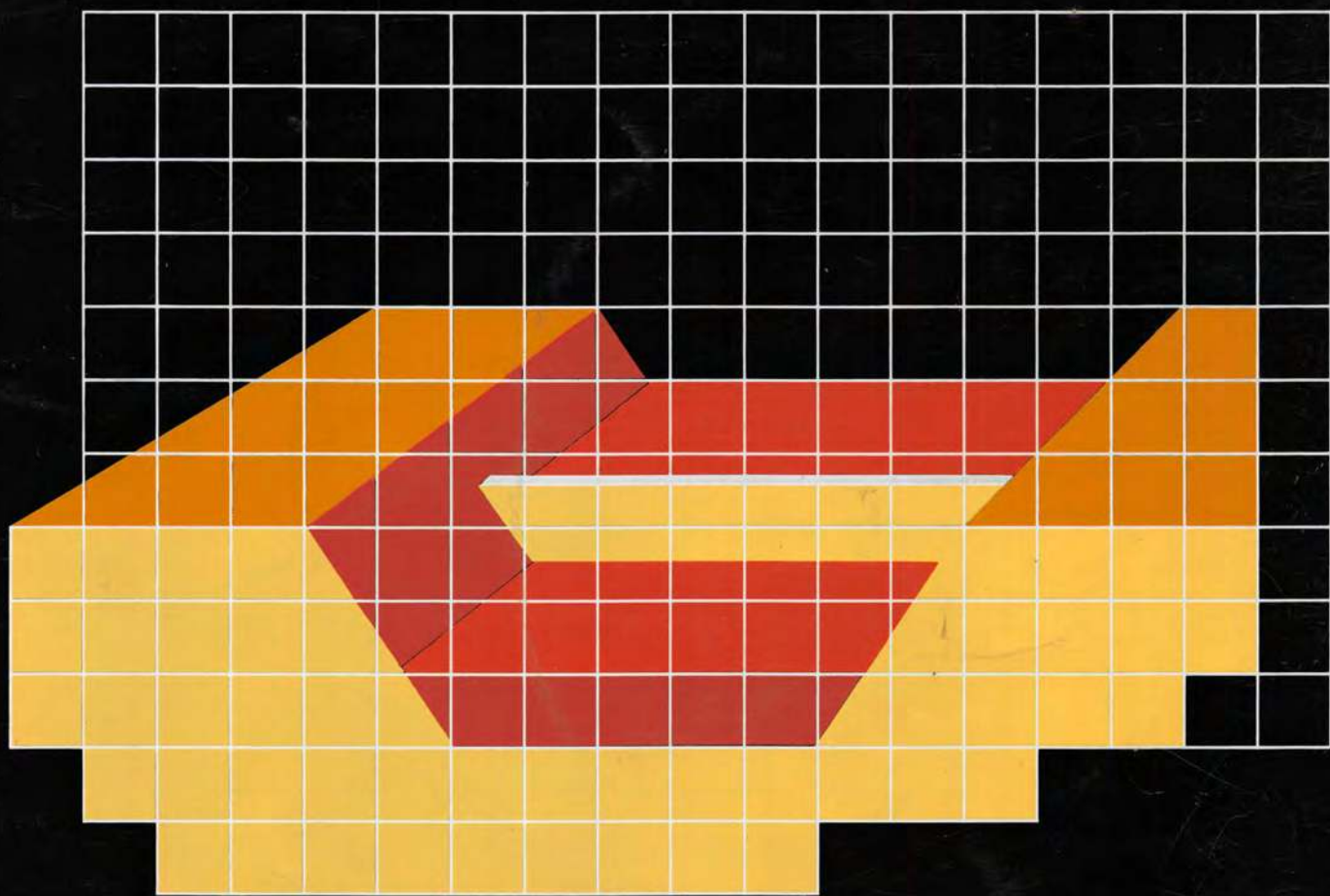

P.J.T. van Bakel

Amis

15. 01/06

860113

**A SYSTEMATIC APPROACH TO IMPROVE THE PLANNING, DESIGN
AND OPERATION OF SURFACE WATER MANAGEMENT SYSTEMS:
A CASE STUDY**

Promotor: dr.ir. W.H. van der Molen, hoogleraar in de agrohydrologie

P.J.T. van Bakel

**A SYSTEMATIC APPROACH TO IMPROVE THE PLANNING, DESIGN
AND OPERATION OF SURFACE WATER MANAGEMENT SYSTEMS:
A CASE STUDY**

Proefschrift

ter verkrijging van de graad van
doctor in de landbouwwetenschappen,
op gezag van de rector magnificus,
dr. C.C. Oosterlee,
in het openbaar te verdedigen
op woensdag 15 januari 1986
des namiddags te vier uur in de aula
van de Landbouwhogeschool te Wageningen



Instituut voor Cultuurtechniek
en Waterhuishouding,

CURRICULUM VITAE

The author was born in Deurne (The Netherlands) on 2 May 1949 and attended the 'Lagere Landbouwschool' at Deurne, the 'Middelbare Tuinbouwschool' at Venlo and the 'Hogere Landbouwschool' at 's-Hertogenbosch. From 1970 to 1976 he studied at the 'Landbouwhogeschool' at Wageningen. He graduated in agrohydrology and catchment hydrology as majors and mathematics as minor.

Since 1976 he has been employed at the Institute for Land and Water Management Research (ICW) at Wageningen as head of the section Water Resources Management. His main task is the development of models for simulating regional water resources systems.

1948

De eerste twee maanden van 1948 zijn zeer goed verlopen. Het aantal bezoekers is zeer groot geweest. Dit is vooral te danken aan de goede samenwerking van de medewerkers. De organisatie is goed verlopen en de bezoekers hebben veel plezier gehad. Het is een succesvolle periode geweest. De komende maanden zullen we ons blijven inzetten voor de bezoekers en de medewerkers. We zullen de organisatie blijven verbeteren en de samenwerking versterken. Het is belangrijk om de bezoekers tevreden te houden en de medewerkers te ondersteunen. We zullen de komende maanden de organisatie blijven verbeteren en de samenwerking versterken. Het is belangrijk om de bezoekers tevreden te houden en de medewerkers te ondersteunen.

aan Els en Paulien

ABSTRACT

Bakel, P.J.T. van. 1986. A systematic approach to improve the planning, design and operation of regional surface water management systems: a case study. Report 13 (special issue), Institute for Land and Water Management Research (ICW), Wageningen, The Netherlands. (XII) + 118 p., 120 eqs., 52 tables, 75 figs., 98 refs., Eng. and Dutch summaries. Also: Doctoral thesis, Agricultural University, Wageningen, The Netherlands.

From an agricultural point of view the most desired surface water level in areas with a shallow groundwater table is low during winter and high during the growing season. Waterboards in the Netherlands try to fulfil this demand by applying different surface water levels in winter and summer.

Because weather conditions vary considerably from year to year, the most desired open water level should be varied too.

The manipulation of weirs by the waterboards is mainly based on practical experience and is not much different from year to year. To obtain better founded rules for surface water manipulation, a study was carried out in a cut-over peat region of about 8000 ha.

For the surface water, the groundwater and the unsaturated soil water system in this area a simulation model was constructed that links these systems mutually and offers the possibility of computing consequences of manipulating open water levels for the water use by crops. The model was calibrated with hydrological data collected in the area. Operational rules for setting weirs and inlet structures were established by comparing the effects of a number of possible rules on depth of groundwater tables and consequent water uptake by the crops for a number of meteorological years. With the operational rules that gave the largest effects on water use by the crops management strategies involving water conservation and additional water supply capacities for sub-irrigation were simulated with the model. The additional transpiration by the crops caused by these strategies were converted to extra yields so that an economical analysis of these strategies became possible. With the aid of the results of this analysis also a demand function for water for the study area was derived. Finally the possible application of the demand function in the water management policy at provincial level was outlined.

The results show that the proposed model offers good possibilities to forecast effects of water management strategies. It can be used by a waterboard to decide upon changes in open water levels that are required in the course of the season because of weather conditions. The weakest point in the model seems to be the lack of knowledge about the possible negative effects of waterlogging on transpiration by crops.

For the conditions prevailing in the study area, water conservation is economically very attractive. Additional water supply to the area for sub-irrigation has a relatively low efficiency, but the economical analysis shows that investments in this strategy may pay off too.

UDC: 631.671:556.182:352.91 556.3.072:631.547 556.512(492.73)

Free descriptors: water management strategies, sub-irrigation, water conservation, water demand function, crop water use, economical analysis, surface water-groundwater-unsaturated soil water simulation model, cut-over peat region, Drenthe

STELLINGEN

I

Door het ter beschikking komen van modellen waarmee de effecten van waterbeheer beter kunnen worden berekend, moet rekening worden gehouden met een ontwikkeling naar een meer genuanceerde verdeling van de waterschapslasten.

II

De stelling van DE ZEEUW dat waterbeheersingsmiddelen doeltreffender zouden kunnen worden gehanteerd indien behalve peilschaalaflezingen ook regelmatig grondwaterstandsmetingen zouden plaatsvinden, geldt nog steeds.

J.W. de Zeeuw, 1966. Analyse van het afvoerverloop van gebieden met hoofdzakelijk grondwaterafvoer.
Proefschrift Landbouwhogeschool, Wageningen.

Dit proefschrift

III

Verificatie van hydrologische modellen dient bij voorkeur te gebeuren aan de hand van de werkelijke verdamping in plaats van aan grondwaterstanden.

H.A.M. Thunnissen, 1984. Toepassing van hydrologische modellen en remote sensing. Deelrapport 4.
Remote sensing studieproject Oost-Gelderland/Nota 1542. ICW, Wageningen.

IV

Bij diepere ontwatering zal de oppervlakkige afstroming steeds meer maatgevend worden voor het ontwerp van waterlopen.

P.J.T. van Bakel, 1984. Invloed van afvoeren tijdens dooiperioden en in de zomer op ontwerp en onderhoud van watergangen. Cultuurt. Tijdschr. 23(6): 301-309.

V

Hydrologische studies die betrekking hebben op ingrepen in de waterhuishouding zijn minder geschikt voor het nemen van beslissingen omtrent ontwerp en beheer indien een economische analyse ontbreekt.

VI

Zolang over de juiste waarden van drainageweerstanden en bodemfysische eigenschappen niet meer bekend is dan thans, is het in de meeste gevallen geoorloofd om bij de koppeling van verzadigde en onverzadigde stroming de kwel als functie van grondwaterstand en open waterpeil in rekening te brengen.

VII

In vele regionale hydrologische studies wordt onvoldoende aandacht besteed aan de ongelijke ligging van het maaiveld.

VIII

In het landelijke gebied zijn inrichting en feitelijk beheer dikwijls niet met elkaar in overeenstemming.

P. Brussel, 1981. Een onderzoek naar het beheer en het gebruik van de cultuurtechnische inrichting in landelijke gebieden. Meded. 88, Vakgroep Cultuurtechniek. Landbouwhogeschool, Wageningen.

IX

In veengebieden kan een belangrijk secundair effect van peilverhoging de vertraging van de afbraak van het veen zijn.

C.J. Schothost, 1977. Subsidence of low moor peat soils in the western Netherlands. *Geoderma* 17: 265-291.

X

De bij de hydrologische systeemanalyse geproduceerde kaarten geven een vertekend beeld van de relatieve belangrijkheid van de diverse stromingssystemen.

G.B. Engelen, 1984. Hydrological Systems Analysis. A regional case study. Report OS 84-20, DGV-TNO/Institute of Applied Geoscience.

XI

Door de mogelijkheden die de huidige computers bieden bij de toepassing van numerieke modellen bestaat het gevaar dat analytische oplossingen van stromingsproblemen naar de achtergrond worden gedrongen, hetgeen ten koste kan gaan van het inzicht.

XII

De kennis omtrent water in de bodem is in de landbouw over het algemeen gering. Dit moet mede worden geweten aan de te geringe aandacht die in de agrarische beroepsopleiding aan de waterhuishouding wordt besteed.

XIII

Iedere Nederlander heeft recht op een basisinkomen.

P.J.T. VAN BAKEL
Planning, design and operation of
surface water management systems.
Wageningen, 15 januari 1986.

PREFACE

This thesis is the final report of a study to which many persons have contributed.

In the first place I wish to express my gratitude to prof.dr. W.H. van der Molen for the valuable discussions I had with him on the subject and his willingness to act as promotor.

I am indebted to ir. G.A. Oosterbaan, Director of the Institute for Land and Water Management Research (ICW), for providing the environmental conditions that were required to carry out the study.

Both the waterboard 'De Veenmarken' and the Government Service for Land and Water Use in Drenthe provided material and personal assistance to carry out field measurements. In this respect I would like to thank their Boards. Particularly the assistance of mr. L.J. de Jong, mr. T. Rozenveld and mr. J.H. Op'tende was highly appreciated.

I greatly appreciate the excellent cooperation with the initiators of this study, ing. W.H. Naarding and ing. F. Hamster, and with mr. G. Nijhof and ing. F. Homma in the 'supervising committee'. The fruitful discussions during the many meetings we had were essential for the progress of the research.

Special thanks go to mr. W. Berg, mr. R.A. Pot, mr. B.W. Staats and mr. L.G. Bartelds for giving the opportunity to share in the agricultural use of their land.

Many thanks are due to my 'colleague in the field' ing. F. Homma. We spent many hours together in discovering the hydrological behaviour of the research area. In determining the stage-discharge curves also the help of mr. J. van der Maas of the Provincial Waterboard Drenthe was appreciated.

I am much indebted to dr. R.A. Feddes. His continuous encouragement was indispensable in helping me through the difficult stages. I am also grateful for his comments on the draft of this report and the many valuable suggestions he made that certainly have led to the improvement of the final report.

A number of ICW-employees were involved in producing basic notes. To be specific: ing. G.W. Bloemen and mr. G.J. Veerman (soil physical properties), mr. D. Slothouwer (economical data), ir. T. van Keulen (water balance calculations), drs. E.H. Smidt (model application), drs. A.B. Pomper (geohydrology) and ir. M. de Graaf (model verification). I am much indebted to them. Furthermore I am thankful to mr. H. Breunissen

and mr. L. Honkoop for their assistance in collecting field data.

Several of my colleagues gave advice or provided basic ideas, notably ir. P.E.V. van Walsum and ir. J.M.L. Jansen for their valuable discussions concerning various problems related with water management, ir. G. Naber for his help in library matters and dr. H. de Bakker for his support in translating the Dutch system of soil classification. I am also indebted to drs. L.J. Locht and drs. J. Vreke for their critical review of the chapter on economics. Special thanks are due to mr. R. Wiebing for the way he supported me with his practical knowledge and experience.

I am most grateful to my 'editor-in-chief' dr. J. Wesseling for the many valuable suggestions concerning organization and contents of this thesis.

Great appreciation goes to mrs. M.J. van Dijk-Janssen for the professional way in which she turned the poorly hand-written versions of this thesis into its present form. The same holds for mr. H. van Ledden for his efforts in making the drawings.

Finally I have to thank mr. M. Jansen, mr. J. Ariese and mr. M.C. van Son for the fine job they did in designing the cover of this book and carrying out the necessary photographic work.

CONTENTS

	page
1. INTRODUCTION	1
2. GENERAL CONCEPTS AND APPLICABILITY OF WATER RESOURCES SYSTEMS ENGINEERING	3
2.1. General concepts of systems engineering	3
2.2. Application of systems engineering in surface water resources management in the Netherlands	4
2.2.1. Structure of the surface water management system	4
2.2.2. Application of Systems Engineering to water management	4
3. DESCRIPTION OF THE RESEARCH AREA 'DE MONDEN'	7
3.1. General	7
3.2. Geological origin	7
3.3. Reclamation history	8
3.4. Agriculture	10
3.5. Topography and soil	10
3.6. Soil improvement	11
3.7. Water management situation	13
3.7.1. Water management at waterboard level	13
3.7.2. Water management at farmers level	14
4. PHYSICAL-MATHEMATICAL APPROACH	16
4.1. Introduction	16
4.2. The atmosphere - crop system	16
4.2.1. Physical mathematical backgrounds	16
4.2.2. Boundaries of the atmosphere - crop system	18
4.2.3. Meteorological and crop data	18
4.3. The unsaturated zone	19
4.3.1. General theory	19
4.3.2. Boundaries of the unsaturated zone	19
4.3.3. Soil physical properties	20
4.4. The saturated groundwater system	21
4.4.1. Mathematical background	21
4.4.2. Boundaries of the saturated system	22
4.4.3. Geo-hydrological schematization	22
4.5. The surface water system	27
4.5.1. Water flow in open watercourses and over weirs	27
4.5.2. Hydraulic properties of watercourses and weirs	28
4.6. Interaction between groundwater and surface water system	30
4.6.1. Theory	30
4.6.2. Field measurements	31
5. MODELING OF THE HYDROLOGICAL SYSTEM	34
5.1. Introduction	34
5.2. System decomposition and boundary conditions	34
5.2.1. Coupling between atmosphere - crop system and unsaturated zone	34

	page
5.2.2. Coupling between unsaturated zone and saturated groundwater system	35
5.2.3. Coupling between saturated groundwater and surface water system	38
5.3. The actual modeling	39
5.3.1. Problem description	39
5.3.2. The open water system	40
5.3.3. The unsaturated system	41
5.3.4. The saturated groundwater system	43
5.3.5. Computational procedure in SWAMP	44
6. MODEL CALIBRATION AND VERIFICATION	46
6.1. Introduction	46
6.2. Calibration of FEMSATS	46
6.2.1. Procedure	46
6.2.2. Results of calibration	49
6.3. Verification of FEMSATS	53
6.4. Verification of the unsaturated flow part in SWAMP	54
6.4.1. Verification with lysimeter data	54
6.4.2. Verification with thermal infrared images	54
6.5. Comparison of simulation results of SWAMP and SWADRE	57
6.6. Regional groundwater flow in SWAMP	58
7. DAY-TO-DAY SURFACE WATER MANAGEMENT AND ESTABLISHMENT OF OPERATIONAL RULES	61
7.1. Choice of rules for the day-to-day surface water management	61
7.2. Establishment of operational rules	65
7.3. Comparison of 'model' surface water management and the management performed by the water-board 'De Veenmarken'	69
8. SENSITIVITY ANALYSIS OF SWAMP	71
8.1. Introduction	71
8.2. Soil physical properties	71
8.3. Drainage resistance	71
8.4. Maintenance of tertiary system	72
8.5. Dimensions of weir	72
8.6. Magnitude of regional flux	73
8.7. Waterlogging damage	73
8.8. Conclusions	75
9. EFFECTS OF SURFACE WATER MANAGEMENT FOR THE ENTIRE AREA 'DE MONDEN'	76
9.1. Introduction	76
9.2. Meteorological and crop data	76
9.3. Seepage fluxes per section	77
9.4. Gross hydrological effects of conservation and water supply	80
9.5. Corrections of the gross hydrological effects	81
9.6. Net hydrological effects of water conservation and water supply	85

	page
10. OTHER ASPECTS OF SURFACE WATER MANAGEMENT	87
10.1. Introduction	87
10.2. Location of reference piezometer	87
10.3. Number of reference piezometers	87
10.4. Influence of maintenance of small canals	88
10.5. Consequences of installation of pipe drainage	88
10.6. Influence of size of sections	89
10.7. Hydraulic aspects of surface water management	90
10.8. Secondary effects	91
11. ECONOMICAL ANALYSIS OF THE EFFECTS OF SURFACE WATER MANAGEMENT	93
11.1. Introduction	93
11.2. Increase in agricultural income due to surface water management	93
11.3. Costs of surface water management	95
11.4. Internal rate of return of surface water management	96
11.5. Supply capacity, water distribution and size of sections based on internal rate of return	97
11.6. Generating a demand function for water	99
SUMMARY AND CONCLUSIONS	102
SAMENVATTING EN CONCLUSIES	105
REFERENCES	109
LIST OF SYMBOLS	113
APPENDIX	117

1. INTRODUCTION

In the history of hydrology one can distinguish a few major trends. From the formulation of the law of Darcy in 1856 until the beginning of the sixties of this century there has been a gradual increase in the knowledge of the physical process of the flow of water in soils and of the mathematical formulation of it. This resulted in a large variety of analytical solutions of flow problems. The introduction of electronic computers created a number of new possibilities namely:

- complex flow systems for which no analytical solutions were possible, can be solved numerically;
- large-scale problems can be handled because computers can manage a great number of data.

Also in the beginning of the sixties people started to realize that water is, to some extent, a non-renewable resource. With a growing population and the increase of economic activities water became scarce, even in a humid country like the Netherlands. This leads to conflicting interests. Because of the complexity of the problem of water allocation a systematic approach using techniques developed in Systems Analysis may be helpful. One of the essential parts of Systems Analysis is the use of a combination of hydrological and management models. Using a computer for simulations, a powerful instrument for water management is at hand, known as 'Water Resources Systems Engineering'. Up till now only a few good examples of successful application of this method to water management problems are available. In fact, in much of this type of work use is made of techniques stemming from Systems Engineering, for instance in the field of hydrological simulation models. The final goal of this kind of modeling is an integrated system of models for the whole terrestrial phase of the hydrological cycle, each model representing a subsystem (e.g. the unsaturated soil water system, the groundwater system, etc.).

In the Dutch situation the planning, design and operation of the water resources systems, particularly at regional/local level at which waterboards function, is very traditional: it is based on practical experience and thumb rules. The day-to-day operation can be characterized in general as some (improved)

version of the so-called complaint system. This means that waterboards act according to simple standard rules and take only action when obviously something goes wrong. Under normal situations operations may approach optimum conditions but without a systematic approach this cannot be proved.

The traditional approach of water management by Dutch waterboards can partly be explained on historical grounds. In the past the main aim of water management was to improve drainage conditions in order to create a more favourable environment for crop growth. During the last decades also measures to increase the water uptake by the crops from the soil have been introduced. This can be realized by raising surface water levels in spring to reduce or stop the drainage of the precipitation surplus, and to supply water from outside the region for sub-irrigation or sprinkling irrigation. Under Dutch conditions good drainage during winter and realization of water conservation and sub-irrigation during the growing season means manipulation of the surface water level. Because of from year to year varying weather conditions a standard operation procedure can be far from optimal.

To improve their management waterboards apply empirical operational rules. Increasing competition between parties concerned in water management, however, makes more objective methods for planning, design and operation necessary. This in fact is the main reason for undertaking this study.

In the waterboard 'De Veenmarken' in the eastern part of the province of Drenthe with an area of about 25 000 ha, farmers constitute the only water users group. The board designed and partly implemented a water conservation and supply plan making optimum use of ground and surface water by means of regulating the level in the open watercourses. The construction of the technical works in the part of the area called 'De Monden', having a size of about 8000 ha, was finished in 1978. This area was used as the pilot area for this study.

The water conservation and supply system was de-

signed in a traditional manner. The design was based on a mixture of empirical design and research findings. The operation of the system was 'heuristic', i.e. the waterboard installed a number of piezometers and used the recorded groundwater depths to manipulate surface water levels. The problem with this method is that one never knows whether the best water management is attained. Therefore the waterboard requested an investigation on the applicability of a more systematic approach to water management problems on regional/local level. This report is the scientific outcome of this study.

In Chapter 2 a description of the general concepts of Water Resources Systems Engineering and the application of this approach to water resources management in the Netherlands is given. In particular, the interdependence between national, provincial and regional water management systems will be pointed out.

Chapter 3 gives a description of the pilot area 'De Monden' while in Chapter 4 a systematic approach needed for the design of models has been given. In Chapter 5 the modeling process itself is described. Calibration and verification of the models and a sensitivity analysis are reported in Chapters 6 and 7.

An essential part of the modeling was the determination of operational rules for the day-to-day surface water manipulation. Chapter 8 is dedicated to this subject.

In Chapter 9 the hydrological effects of water conservation and water supply are simulated with the aid of the developed models. On the basis of results obtained with the models a number of practical aspects of surface water management are dealt with in Chapter 10. These aspects concern the effects of installation of a pipe drainage system, the maintenance of watercourses and the optimal location of piezometers to be used as a basis for surface water management measures.

In Chapter 11 the economical aspects of surface water management will be treated. Based on the economical analysis a demand curve for water to be supplied to the area 'De Monden' has been generated. Finally the interaction between surface water management on local/regional level and the provincial and national water resources management systems is discussed.

2. GENERAL CONCEPTS AND APPLICABILITY OF WATER RESOURCES SYSTEMS ENGINEERING

In the introduction, it has been suggested that a systematic approach using techniques developed in Systems Analysis might be helpful in improving the water management of a particular region. This approach, called Water Resources Systems Engineering, will be discussed now in more detail, starting with the general concepts of Systems Engineering. Application of this approach will be discussed in the context of the Dutch national and provincial water resources management systems.

2.1. GENERAL CONCEPTS OF SYSTEMS ENGINEERING

A growing population and an increasing prosperity requires efficient use of natural resources. Weighing interests and avoiding conflicts in water management require more technology than currently assumed. This implies that engineers and research workers should place more emphasis on 'prescriptive' rather than on 'scientific' or 'descriptive' problem-solving. The engineering process should be integrated with elements of other disciplines, particularly economics and all aspects involved should be considered simultaneously. Such an integration requires a systematic approach - the Systems Approach. The use in this approach of formalized procedures, particularly mathematical models, is called Systems Analysis or Systems Engineering.

The book of MAASS et al. (1962) is considered to be the first publication in which the specific features of application of Systems Analysis to Water Resources Management were outlined. The approach utilizes existing principles and techniques; its only novelty is its holism (HALL and DRACUP, 1970): 'Systems analysis is the science of selecting from a large number of feasible alternatives, involving substantial engineering control, that particular set of actions which will best accomplish the overall objectives of the decision makers, within the constraints of law, morality, economics, resources, political and social pressure, and laws governing the physical life and other natural sciences'.

Hall and Dracup distinguish between 'Systems Analysis' as defined above and 'Systems Engineering' which also involves subjective elements. Because, in the

opinion of the author, the latter especially is true in water resources management, the term Systems Engineering is preferred. The continuity of engineering and the Systems Approach is illustrated by TOEBES' (1975) cryptic remark that 'Systems Engineering is engineering, only more so'.

The main characteristics of Systems Engineering according to TOEBES (1975) are:

- the combination of technical and economic disciplines;
- systems orientation. A system can be defined as a set of components interacting in a predictable, interdependent way. It is characterized by a system boundary with inputs and outputs, interrelations among (sub)elements, input, output and feedback (HALL and DRACUP, 1970). Reality is modelled as a group of subsystems, whose outputs determine the extent to which the objectives are achieved. Modeling simplifies the problem by taking into account only the most important processes and interrelations;
- the definition of the objective function(s). Again quoting HALL and DRACUP (1970): 'An objective is any statement by which the consequences or output of a system can be determined, given the policy, the initial stage of the system and the system parameters'. Thus, the objective function is the mathematical expression of the objective;
- parametric design. By changing the objectives systematically, alternatives can be obtained which are fundamentally different;
- mathematical modeling. Several types of mathematical models are applied in order to avoid the inaccuracy of verbal expressions, thus allowing formal optimization. This is perhaps the most striking feature of Systems Engineering. Besides, the recent development of the digital computer, with its capability of solving large sets of simultaneous equations, has allowed Systems Engineering to flourish.

The framework in which mathematical models are used in Water Resources Systems Engineering has been depicted in Fig. 2.1. A distinction is made between two main types of models, descriptive and prescriptive ones. Descriptive models generate relations, e.g. the amount of water pumped from an aquifer and the draw-

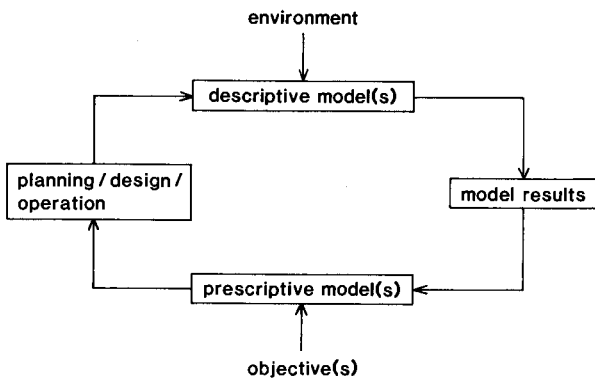

Fig. 2.1. Schematic representation of using mathematical models in Water Resources Systems Engineering

down of the phreatic level. Prescriptive models evaluate the outputs of descriptive models in terms of the objective function(s), and thus form the basis for policy decisions.

In recent years there has been a dramatic rise in the popularity of Systems Engineering, as shown by an explosive increase of the number of publications on this subject. In spite of this popularity the influence of Systems Engineering on the actual improvement of water resources management is still questionable, and most of the reported applications can be classified as 'letters of intention'. As stated by DE DONNEA (1978): 'The influence of Systems Engineering on water management is not proportional to the intellectual efforts'.

In the Netherlands proper water resources management seemed to be not urgent because of evident abundance of water. Due to growing demands, only recently the need for a more optimal use of water resources was felt. To obtain this goal, also Systems Engineering was applied, as will be discussed below.

2.2. APPLICATION OF SYSTEMS ENGINEERING IN SURFACE WATER RESOURCES MANAGEMENT IN THE NETHERLANDS

2.2.1. Structure of the surface water management system

Because of geographical, topographical and climatological reasons, the main water management problem in the Netherlands has been for a long time to avoid crop damage caused by an excess of water. For this purpose dykes were constructed in low-lying areas and the land was drained by enlarging natural streams and digging of additional watercourses. Since the creation of organizations like waterboards and polder districts, practical experience and research have made

water management more sophisticated. During the last decades waterboards pay considerable attention to water supply for agriculture during dry periods and to non-agricultural interests like nature. Rapid progress is now being made in the incorporation of these aspects into laws and administration.

In the water management in the Netherlands one can distinguish three governmental levels (Fig. 2.2):

- national level. For the management of the national surface water system a special water authority the 'Rijkswaterstaat', falling under the Ministry of Traffic and Communications is responsible;
- provincial level. The 'Provinciale Waterstaat' must ensure that the surface water system in the province is properly managed;
- regional/local level. Locally and regionally the surface water management is carried out by special bodies, the waterboards. There is a tendency to reduce the number of waterboards, while with the introduction of the Public Law on Pollution of Surface Water a number of waterboards has the care for the quality of the surface water too. The waterboards are supervised by the provincial water authority.

The scheme in Fig. 2.2 suggests that there is a strong interdependence between the different levels. Although at least some feed-back mechanisms are operational, the actual situation is not so clear because at each level the requirements posed by the higher level are not always known. As an example waterboards have to know the surface water supply possibilities offered by the province in order to optimize their surface water management, but the provincial authority does not know the water supply possibilities given by the national authority. Hence it cannot realize optimum water supply possibilities for the different waterboards. This situation is mainly caused by the fact that at all levels there is a lack of good methods to establish standard water management policies.

2.2.2. Application of Systems Engineering to water management

At national level, the main objective is to maximize total revenues. The national water authority therefore has to consider measures whose influence extends over more than one province and affect more than agriculture alone. For example, the distribution of Rhine water is based on demands for agriculture, for shipping, for power generation and for domestic water supply.

To optimize the management of national water re-

Fig. 2.2. Structure of the water resources management system in the Netherlands

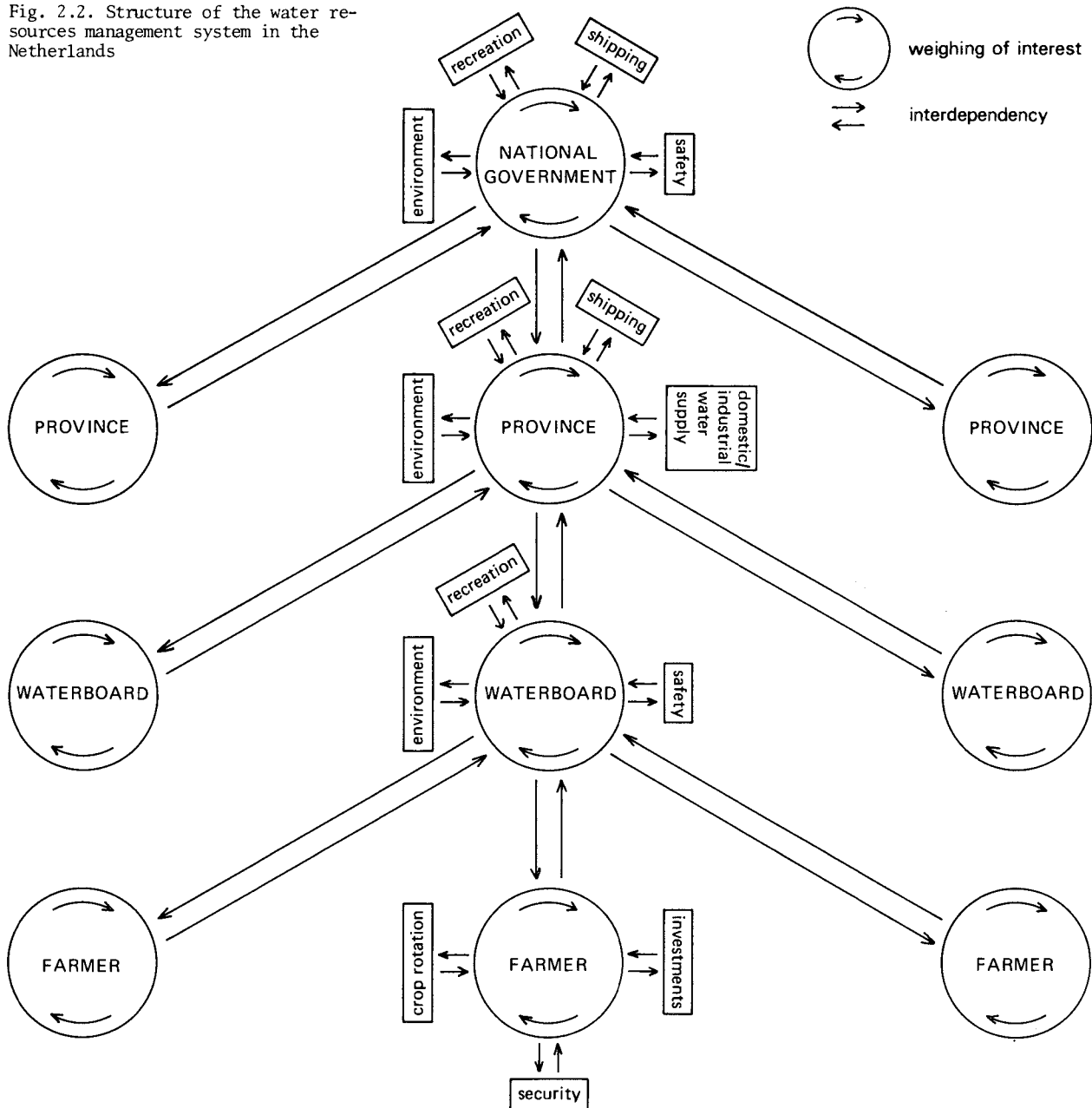

sources the Dutch government initiated in 1976 the study 'Policy Analysis for the Water Management of the Netherlands' (PAWN). The primary tasks of PAWN were (ABRAHAMSE et al., 1982):

- development of a methodology for assessing the multiple consequences of water management policies;
- application of the methodology to develop alternative water management policies for the Netherlands and to assess and compare their consequences;
- creation of Dutch capability for further analysis of water management.

The PAWN-study clearly illustrates the use of Systems Engineering because:

- a distribution model for the national water system was constructed;
- models were developed to calculate the various demands for water;
- the effects of policies for water allocation among various users are expressed in benefits and costs for all users.

In Dutch legislature the supervision of most of the laws concerning environmental problems is put in the hands of the provinces. The new Groundwater Law prescribes that the provinces have to develop a master plan for their groundwater management. The same policy will be followed with the Water Management Law.

The application of Systems Engineering at provin-

cial level was pioneered by the Commission for Water Management in the province Gelderland (CWG). Some prescriptive models were developed, but especially the construction of hydrological simulation models was particularly successful (DE LAAT and AWATER, 1978). The use of descriptive and prescriptive models in conjunction, however, was less satisfactory.

At the waterboard's level the application of Systems Engineering is least advanced, probably because the integration of the interests of the various groups was not considered to be important up to now. The complaint system, used by the waterboards, can satisfy the demands of a limited number of users provided their interests are not too divergent. Recent developments, however, demand a critical appraisal of current management practices:

- intensive agriculture demands a sophisticated water management which balances drainage requirements for heavy machinery and water requirements for high-yield crops;
- although agriculture is by far the most important user of water in the Netherlands, the needs of other users have to be accounted for too;
- a good water management is essential for conservation of nature and water management practices can influence the possibility of groundwater extraction for domestic and industrial purposes.

Because of the structure of the surface water management system in the Netherlands an overall optimization is quite difficult. A workable procedure with respect to surface water quantity may in principle be constituted along the following lines.

At users level, a demand function for water can be established giving the relation between quantity of demanded water and marginal productivity. From the user demand functions the waterboard can generate a regional demand function for water. The provincial water authority can use the waterboard demand functions, together with demand functions of other users with interests on provincial level, to generate a provincial demand function for water. Finally, the national water authority can use provincial demand functions together with demand functions of other users on national level to optimize the management at national level. This procedure should yield supply functions of water to the provinces. In this respect a supply function is the relation between quantity of supplied water and costs per unit of water. Supply functions on provincial level should in turn yield supply functions for the different waterboards within the province. With this framework once given a waterboard can optimize its

surface water management system, both with respect to design and operation.

In the suggested approach, Water Resources Systems Engineering must be applied at all levels. This study attempts to extend the application of Systems Engineering at waterboard level.

As already mentioned in the introduction, the water conservation and supply system for the study area 'De Monden' was designed in a traditional way. The manipulation of water levels in the water courses is done empirically with the implicit objectives to minimize water damage to crops because of insufficient drainage and to maximize effects of water conservation and water supply on crop transpiration and production. The first objective requires a low surface water level, the second a high one. Fortunately, crops grow in summer, while good drainage is required mainly in winter. Optimization therefore is complicated and requires a more systematic approach, used in this study.

The main objectives of the study are:

- to determine the optimal surface water manipulation for maximum crop production, given technical and administrative constraints;
- to find out which measures should be taken by the waterboard and whether they are acceptable for the farmers;
- to investigate the economical feasibility of water conservation and supply by means of sub-irrigation.

Besides some other objectives should be taken in mind too:

- the optimization of the surface water manipulation should be capable to give a demand function for water to be used in the weighing process on provincial level;
- the solution obtained for the pilot area must be such that it can be applied to other areas with the same kind of surface water management system;
- the design criteria for water conservation and water supply plans are mainly based on practical experience. Part of this study therefore will be the evaluation of current design rules.

3. DESCRIPTION OF THE RESEARCH AREA 'DE MONDEN'

3.1. GENERAL

The research area 'De Monden' being about 8000 ha is part of an almost completely reclaimed, former raised bog region. Its geographical position is given in Fig. 3.1. The area covers about one-third of the territory of the waterboard 'De Veenmarken'.

In the next sections the geological origin, the reclamation, history, the present agricultural situation, the topography and soil types, the soil improvement and the water management situation of the area will be discussed.

3.2. GEOLOGICAL ORIGIN

Much of the following information is obtained from BODEMKAART VAN NEDERLAND (1980). The eldest deposits in the area are the tertiary Breda and Scheemda Formations. The top of these marine clays and fine sandy layers is situated at about 80 m below sea level. At the beginning of the Quarterny coarse sand has been deposited by rivers. Of these deposits (Har-

derwijk and Urk/Enschede Formations) about 40 m is left. During the Cromerian phase of the Quarterny, a period with alternating warmer and colder climates, finer layers were deposited and in some places peat started to grow. During the Elsterian land ice reached the northern part of the Netherlands. The ice carved very deep gulleys that were filled later on with melt water deposits (Peelo Formation). In the research area these deposits of fine-graded material form a layer of 15 m at the utmost. During the next glacial stage, the Saalian, a large part of the Netherlands was covered with land ice. In this period a northeast-southwest directed ice pushed ridge, the 'Hondsrug', was formed. The melt water eroded a wide and deep valley east of this ridge of which the present Hunze valley forms a remnant. Deposits from this period consist of rather coarse sand (Drente Formation). In the Eemian Interglacial the filling continued with finer material. During the Weichselian Glacial most of the Eemian deposits were eroded. Also much wind erosion took place, resulting in deposits of 'old cover sands' in the lower parts of the area. Later on a more local wind erosion resulted in the forming of low dune ridges of 'young cover sands' (Twente Formation). As a result, drainage was restricted and a lacustrine organic mud called 'gyttja' was formed in the stagnant pools.

During the Holocene a vast raised bog area was formed. In principle the following phases of peat forming can be distinguished (CASPARIE, 1972):

- in the lowest places of the Hunze valley drainage was hampered by cover sand ridges. In the depressions peat was formed. On higher places a wood, mainly existing of *Betula*, developed;
- about 4000 years B.C. the climate became somewhat warmer and brook peat extended at the cost of the wood;
- about 3000 years B.C. on most places the peat layer had grown so thick that the peat forming organisms became more and more dependent on rain water for their nutrition. Sphagnum became the most important peat forming organism;
- from 2000 years B.C. the oligotrophic sphagnum peat extended to the originally higher places and the peat became even more oligotrophic. The sphagnum peat can be divided in old sphagnum peat (oligo-

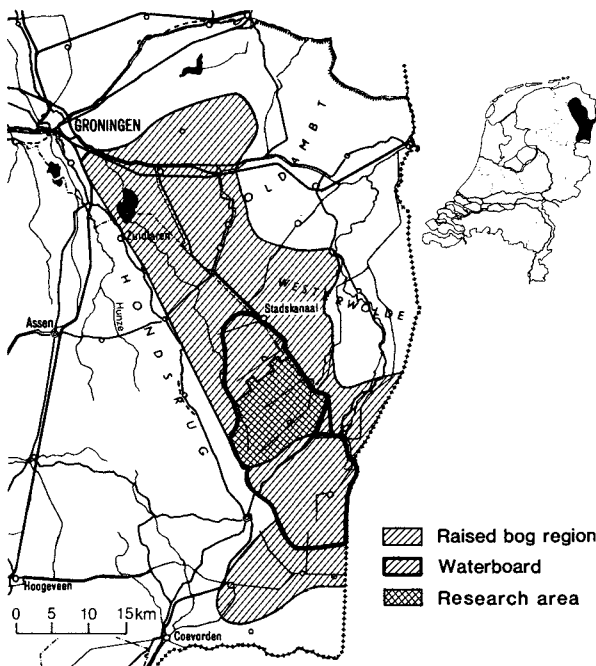

Fig. 3.1. Topography of the former raised bog region, the waterboard 'De Veenmarken' and the research area 'De Monden'

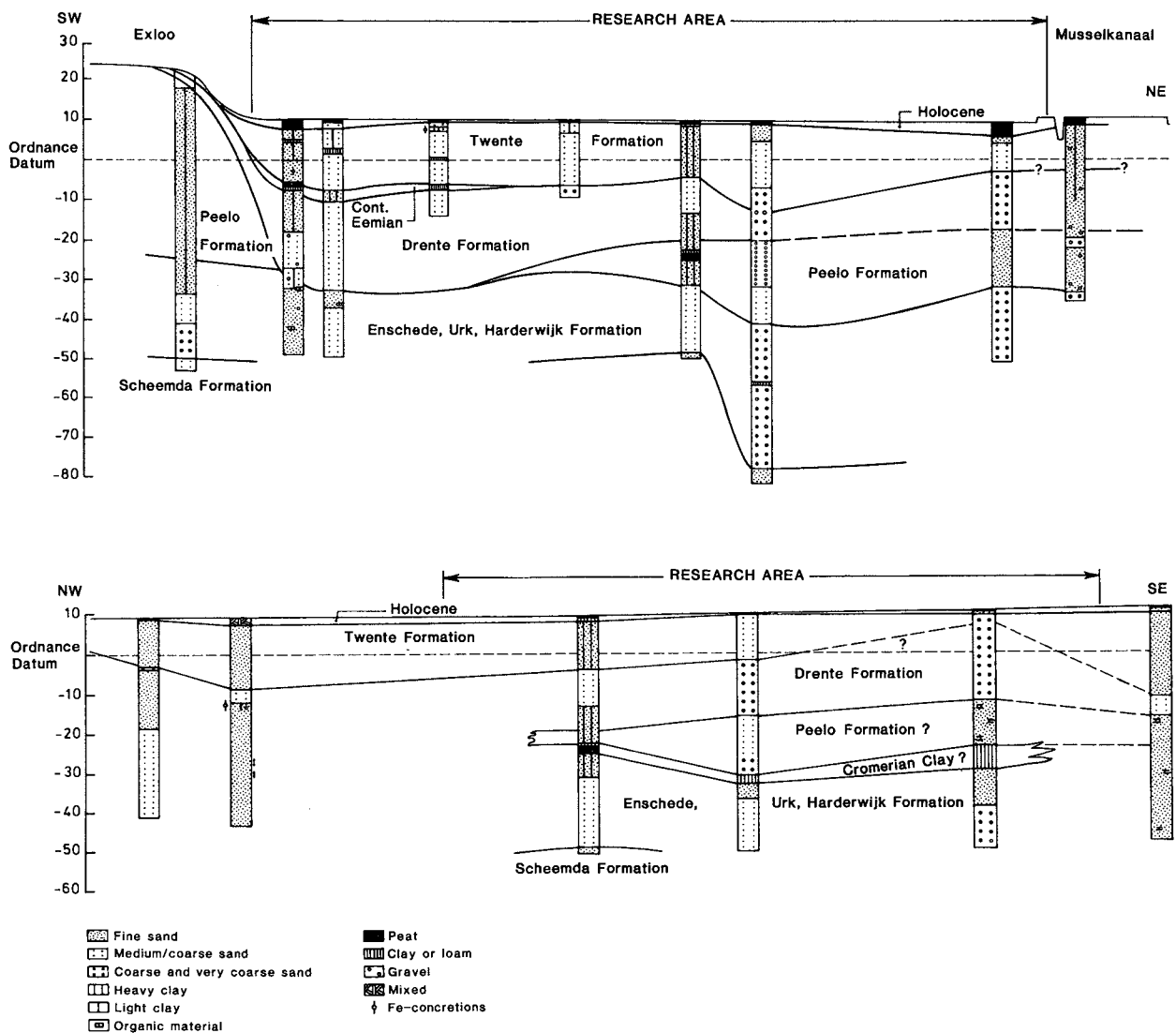

Fig. 3.2. Geological cross-sections over the research area 'De Monden' showing the extension of the different geological formations

trophic), young sphagnum peat (strongly oligotrophic) and a white loose peat called 'bolster' (upper not humified layer of the young sphagnum peat).

Two geological cross-sections compiled by POMPER (1981) clearly demonstrate the geological history outlined above (Fig. 3.2). For the composition of these profiles data from the archive of the National Water Supply Institute and from ten straight-flush drillings, especially made for this study were used. The upper boundary of the Scheemda Formation is situated roughly at 50 m below sea level. Above this the Harderwijk, Enschede and Urk Formations are present. The Peelo Formation reaches almost to the ground surface at the Hondsrug, but in the Hunze valley this

layer has almost completely disappeared by erosion. Only at a few places the Cromerian clay was found between the Urk and Peelo Formations which confirms its very local occurrence. The Drente Formation is present everywhere east of the Hondsrug, with the thickest layer in the Hunze valley. The deposits from Eemian origin are only present at the western border of the Glacial valley. Finally the profiles show how thin the recent Holocene deposits are nowadays. This is mainly caused by human activities.

3.3. RECLAMATION HISTORY

The thick peat layers were an attractive source

Fig. 3.3. Pattern of main and secondary canals in the reclaimed peat region (after 'Sectoradvies Landschapsbouw voor het deelgebied Kanaalstreek', 1980)

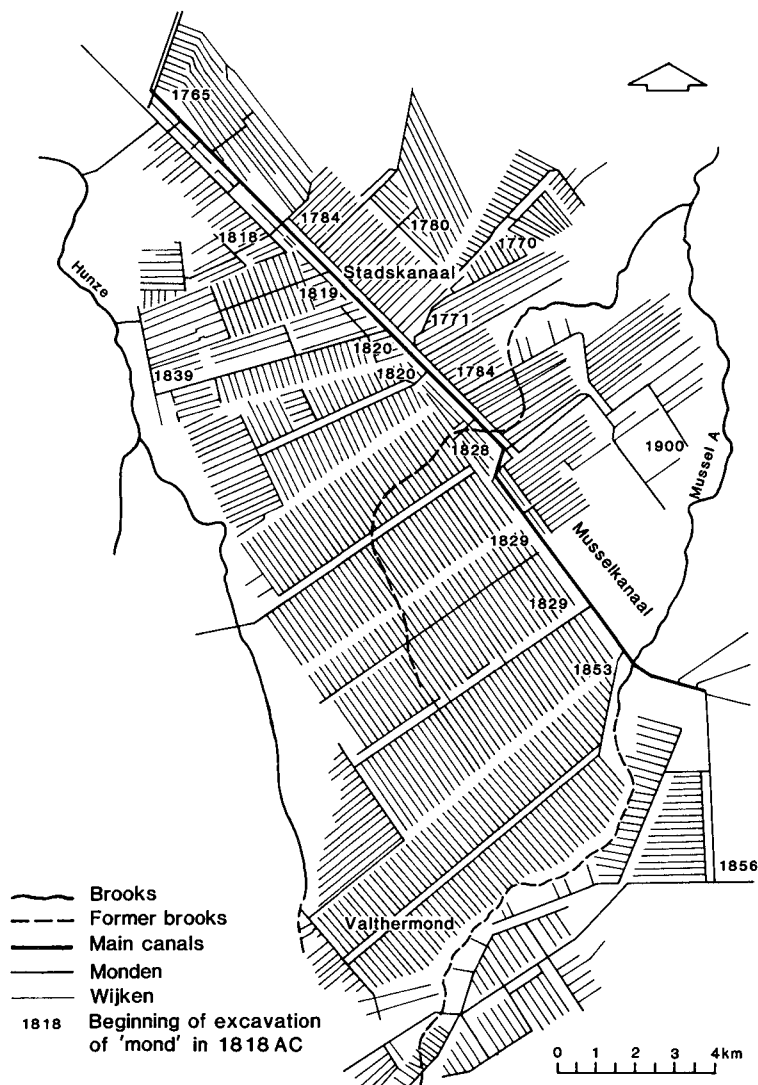

of energy. Already in the twelfth century sporadic peat-harvesting took place along the higher sand ridges.

In the beginning of the 17th century the systematic peat harvesting and reclamation started, mainly under the supervision of the city of Groningen. For the transport of the dried peat by ship, the Stadskanaal was excavated, a main canal running from Groningen in south-east direction. From the Stadskanaal the systematic reclamation of the area was undertaken. This happened by excavating main canals (so-called 'monden') perpendicular to the Stadskanaal. Next smaller laterals, so-called 'wijken', were dug orthogonal to the main canals at mutual distances of 150 (oldest reclamations) to 200 m (younger reclamations). In this way a regular pattern of water courses resulted. Fig. 3.3 gives this pattern together with the approximate years of construction.

The reclamation of the area was closely related with the peat harvesting (BOOY, 1956). Excavation of

a new 'wijk' started with harvesting a strip of peat with the width of the planned canal. The next year a parallel strip was harvested to create a dumping place for the sand from the canal to be excavated. Between the 'wijken' every year a strip of peat was harvested. The upper 0.5 m of white loose peat ('bolster') which was not very suitable for fuel was dumped in the previously excavated pit. After completion of the peat harvesting, the area was levelled and the sand depot along the 'wijk' was spread over the field. For drainage purposes a main ditch called 'zwetsloot' was excavated midway between the 'wijken' and when necessary smaller drainage ditches were created. Fig. 3.4 gives a schematic diagram of the various water courses.

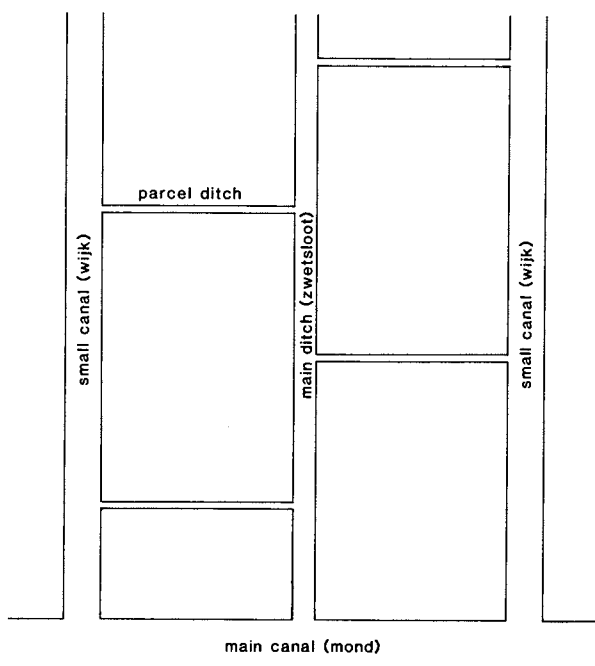

Fig. 3.4. Schematic diagram of different watercourses and their names

3.4. AGRICULTURE

The soil was originally used as arable land because the city of Groningen prohibited the use as grassland. On the other hand the city offered its refuse free of charge during the first 10 years of cultivation. Therefore the poor chemical fertility could be overcome and the advantage of the favourable water supply capacity of the profile could be used.

After the introduction of chemical fertilizers, around 1880, and the establishment of the potato-starch and straw-carton industry the share of potatoes in the cropping pattern increased till about 50%. The remainder crops are mainly cereals and sugar beets.

Of the total area of 7900 ha, approximately 6000 ha is used by agriculture. The acreages of the main crops are given in Table 3.1. These data show that the area remained almost completely arable. One of the problems in the area is that the income of the farmers depends largely upon the market prices of potato starch.

Due to the rapid mechanization during the last

	Cereals	Potatoes for industrial use	Sugar beets	Grass-land	Fodder maize	Miscellaneous
Absolute (ha)	1500	2900	1150	200	200	50
Relative (%)	25	48	19	4	3	1

Table 3.1. Acreage of the main crops in 'De Monden' in 1980 (after LEI and CBS, 1980)

decades the size of the farms is too small. Already in 1965, when the average size of the farms was about 20 ha, this problem existed (MEIJERMAN, 1966). The present average size of 30 to 35 ha still is too small.

3.5. TOPOGRAPHY AND SOIL

The geological origin, the reclamation and the subsequent agricultural use are the most important factors which constitute the present topography. The elevation of the area shows the presence of the 'Hondsrug' and the cover sand ridges (Fig. 3.5).

A soil map of the area is presented in Fig. 3.6. The profiles depicted on this map can be classified in four main groups:

- deep peat soils (units zVc, aVc, iVc). These soils have more than 40 cm peaty material (>15% organic matter) between 0.0 and 0.8 m and the upper boundary of the sandy subsoil is more than 1.2 m below soil surface. Soil profiles of this group are situated in a belt along the Hondsrug and in the depressions between sand ridges in the reclaimed peat area;
- moderately deep peat soils (units aVz, zVz, iVz, iVp). As above, but with the upper boundary of the sandy subsoil within 1.2 m below soil surface. These soils are found in places with a relatively higher elevation of the sandy subsoil;
- peaty soils (units zWz, iWz, iWp). The thickness of the peaty layer is less than 0.4 m. Most of the soils of the reclaimed peat area belong to this group;
- sandy soils (units Hn21, pZn21). The thickness of the peaty layer in this soil type is smaller than 0.05 to 0.15 m. The geographical position coincides in general with sand ridges.

As can be deduced from the description given above there is some systematic relation between the spatial distribution of soil types and the topography. This is mainly due to the original topography of the mineral subsoil and the reclamation.

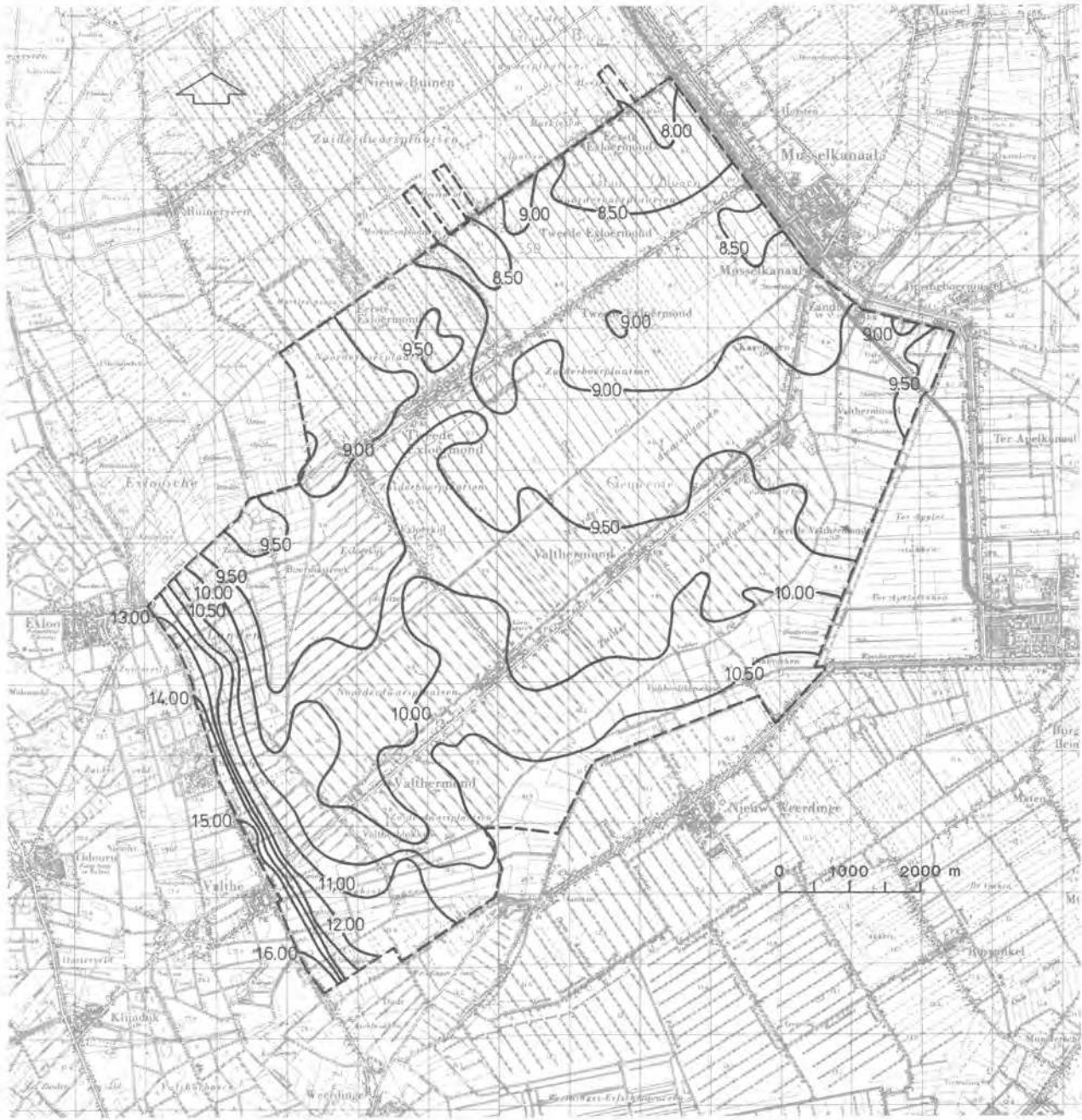

----- Boundary of study area

Fig. 3.5. Elevation map of the area 'De Monden'. Figures refer to elevation above Ordnance Datum

3.6. SOIL IMPROVEMENT

During reclamation often serious mistakes were made. According to Van DUIN and Van WIJK (1965) the following mistakes can be distinguished:

- the water level in the 'wijken' during the peat harvesting was too high, so not all peat could be removed and there remained a low permeable layer;
- due to a shortage of sand the reclaimed soil was

- too humous;
- the depth to which peat was removed varied from year to year which caused differences in elevation;
- during the reclamation low permeable layers formed by non-harvested peat and cemented B-horizons were not broken;
- the amount of 'bolster' was not always sufficient. Often part of it was burned or used for peat litter;
- the sand cover forming the top layer was not spread equally;

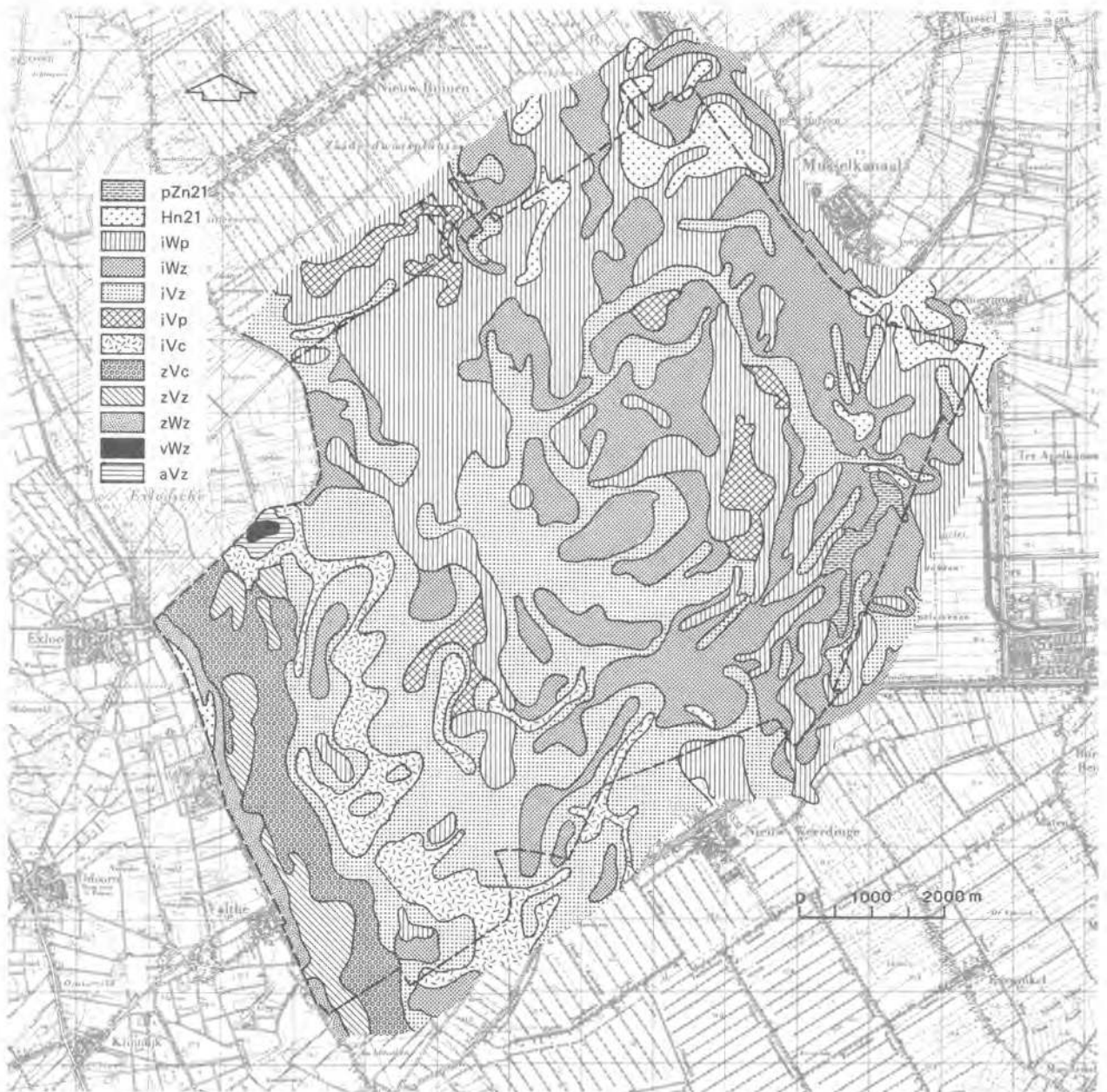

Explanation of codes

Soilgroups

- H : Humus podzols
- Z : Sandy gley soils
- V : Deep peat soils
- W : Shallow peat soils over-lying sandy bog floor

Topsoils

- a .. earthified peat
- i .. man - made topsoil, 10 - 20 cm thick, peaty to humous fine sand
- p .. dark, humous topsoil, fine sand
- v .. peaty topsoil
- z .. man - made topsoil, 20 - 30 cm thick, humous fine sand

Subsoils

- .. c *Carex* peat
- .. n hydromorphic characteristics
- .. p podzolised sandy bog floor
- .. z non - podzolised sandy bog floor
- .. 21 sand to loamy fine sand

E.g. pZn21 is a sandy gley soil with a dark topsoil, developed from sand to loamy sand.

Fig. 3.6. Soil map of the area 'De Monden'

- the sand from the canals was too loamy or the amount was too small.

The mistakes causing insufficient rooting possibilities and a bad vertical water movement, have also led to considerable differences in soil profiles over short distances which reduce the agricultural quality of the soil. To compensate losses of organic matter in the top layer, each year about 0.5 cm of peat was

brought up from the subsoil by ploughing. This caused a steady reduction of the thickness of the peat layer below the root zone that acts as a water reservoir. As a consequence, the soil became more sensitive to drought and wind erosion (WIND, 1979; BRUSSEL, 1980).

In a number of cases soil improvement offers a possibility to raise the agricultural value or to stop further soil degradation. According to BOOY et al. (1975) the improvements given in Fig. 3.7 can be applied.

Fig. 3.7. Relation between soil type and method of soil improvement (after Booy et al., 1975)

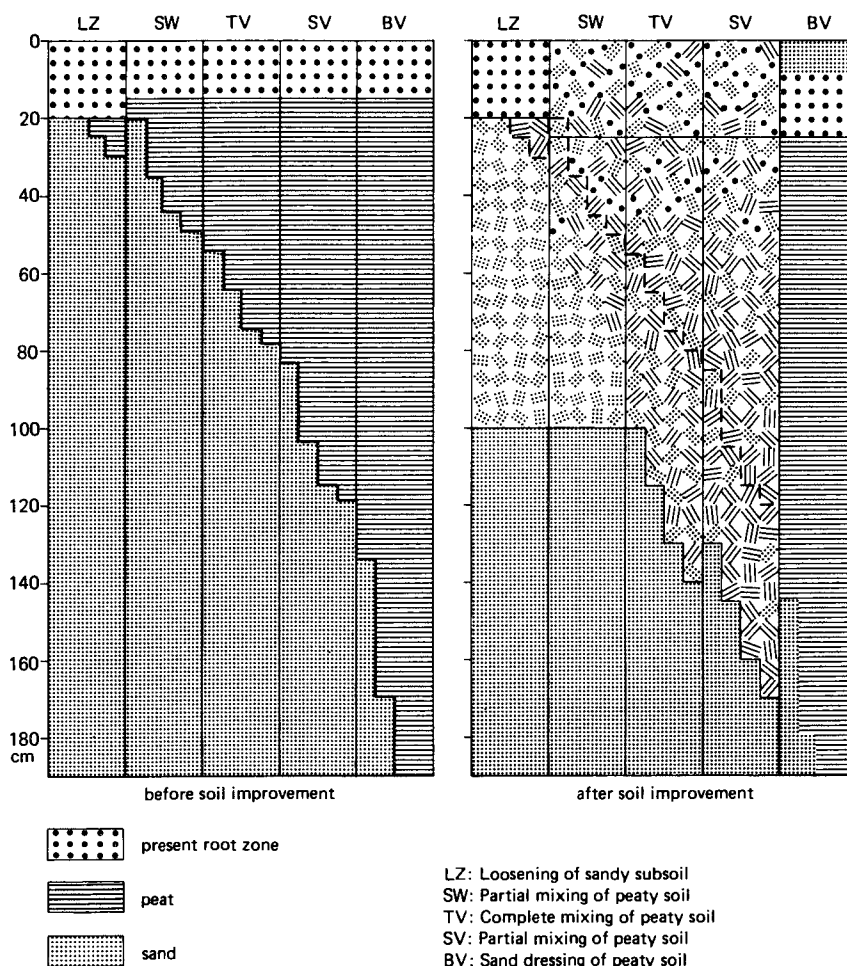

Sandy soils with a thin humous root zone and a dense subsoil can be improved by subsoiling. Care should be taken that the top soil does not become too low in organic matter. Negative effects of this type of improvement have been found for grassland (SCHOTHORST and HETTINGA, 1983). The root zone of soils in the reclaimed peat area preferably must have an organic matter content of 10 to 15%. To prevent oxydation of the remaining peat layer this layer can be mixed with the sandy subsoil. After mixing the subsoil consists of peat and sand. Each year a thin layer of the subsoil must be mixed with the top soil to compensate for losses in organic matter. An additional advantage of this method was the improved vertical water movement (both percolation and capillary rise) and the enlargement of the root zone.

Deep peat soils can be dressed with sand in order to improve the workability and to diminish the sensitivity for night frost. However, this way of soil improvement is rather expensive and can only be executed when the depth of the sandy subsoil is not more than 3 m.

On a number of experimental fields the effect of soil improvement on crop yield has been investigated. These experiments are summarized in Table 3.2, which gives the long term average increase in yield

Table 3.2. Averaged extra yield (in %) in Borgercompagnie (30 cm peat in subsoil) and Emmercompascuum (80 cm peat in subsoil) due to soil improvement

Crop	Borgercompagnie	Emmercompascuum
Summer wheat	15	1
Oats	15	0
Potatoes	9	0
Sugar beets	14	1

of four crops due to soil improvement. Evidently soil improvement is most effective for soils with a limited peat thickness in the subsoil (WIEBING and WIND, 1979).

An inventory in 'De Monden' showed that nearly all peaty soils have been improved. This fact is important when soil physical conditions are considered later on.

3.7. WATER MANAGEMENT SITUATION

3.7.1. Water management at waterboard level

The system of main canals ('monden') and small canals ('wijken') excavated for the peat harvesting was very suitable for the discharge of drainage water

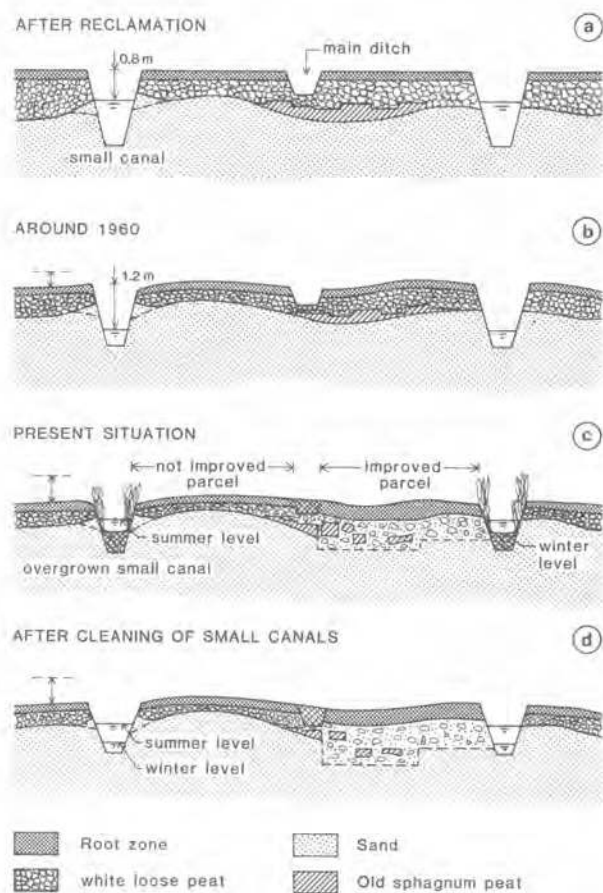

Fig. 3.8. Schematic presentation of development stages in the water management situation

from main ditches and parcel ditches. Besides these watercourses themselves had a drainage function. Due to the loss of organic matter in the topsoil, and subsidence of peat layers in the subsoil the soil surface became uneven and the drainage situation deteriorated (Fig. 3.8a).

Till about 1960 the transport of agricultural products took place by ship, so high water levels in the canals were needed. Therefore farmers started to dam off the small canals in order to create a lower open water level during periods without transport.

In the beginning of the sixties road transport became common in the area and so the water level could be lowered in all canals (Fig. 3.8b). Next for mechanization purposes the small parcel ditches and some of the main ditches were filled up by the farmers.

Maintaining a low water level throughout the year caused, however, a shortage of water during dry periods in summer. In order to prevent this shortage, at least partially, the water level should be raised in spring before the end of the period with a rainfall surplus, in order to conserve water. In dry growing seasons, however, this water conservation is insuffi-

cient to meet evaporation demands. To overcome this problem soil improvement and additional water supply are needed. By maintaining a high open water level during the whole growing season, subsurface irrigation occurs (Fig. 3.8c).

To improve conditions a new type of water management was required consisting of a combined system of drainage, water conservation and sub-irrigation. In the area 'De Monden' this was realized by constructing a number of new weirs and inlet structures. The area was divided into 13 sections with different open water levels. To manipulate open water levels weirs were made adjustable. The geometry of the inlet structures is based on a supply capacity of $0.3 \text{ l} \cdot \text{s}^{-1} \cdot \text{ha}^{-1}$ (about $2.5 \text{ mm} \cdot \text{d}^{-1}$).

The final system consists of 20 adjustable weirs and 10 inlet structures (Fig. 3.9). The adjustable weirs are provided with sensors so that the weir is raised or lowered automatically dependent on the water flow.

3.7.2. Water management at farmers level

The original dimensions of the small canals were 5.00 m bottom width, 2.60 m depth and side slopes 1:1.5. For the discharge of drainage water from adjacent sites the capacity of these canals was far too large.

After the canals lost their transport function the water levels were lowered to a depth of about 1.20 m below soil surface. As a consequence the density of the ditch drainage system could be reduced. Farmers started to fill up the field ditches and main ditches that hampered mechanization. At present the small canals form the main drainage system. Because of the large water transport capacity of these canals their maintenance was neglected. Such canals, however, can become overgrown within 10 to 20 years, resulting in a deterioration of their hydrological functioning (Fig. 3.8c). Nowadays the majority of the small canals is seriously overgrown. This means that they have to be cleaned and reshaped to restore or improve their hydrological functioning (Fig. 3.8d). A complete recovery of the small canal system is foreseen (HERIN-RIGHTINGSPROGRAMMA, 1979).

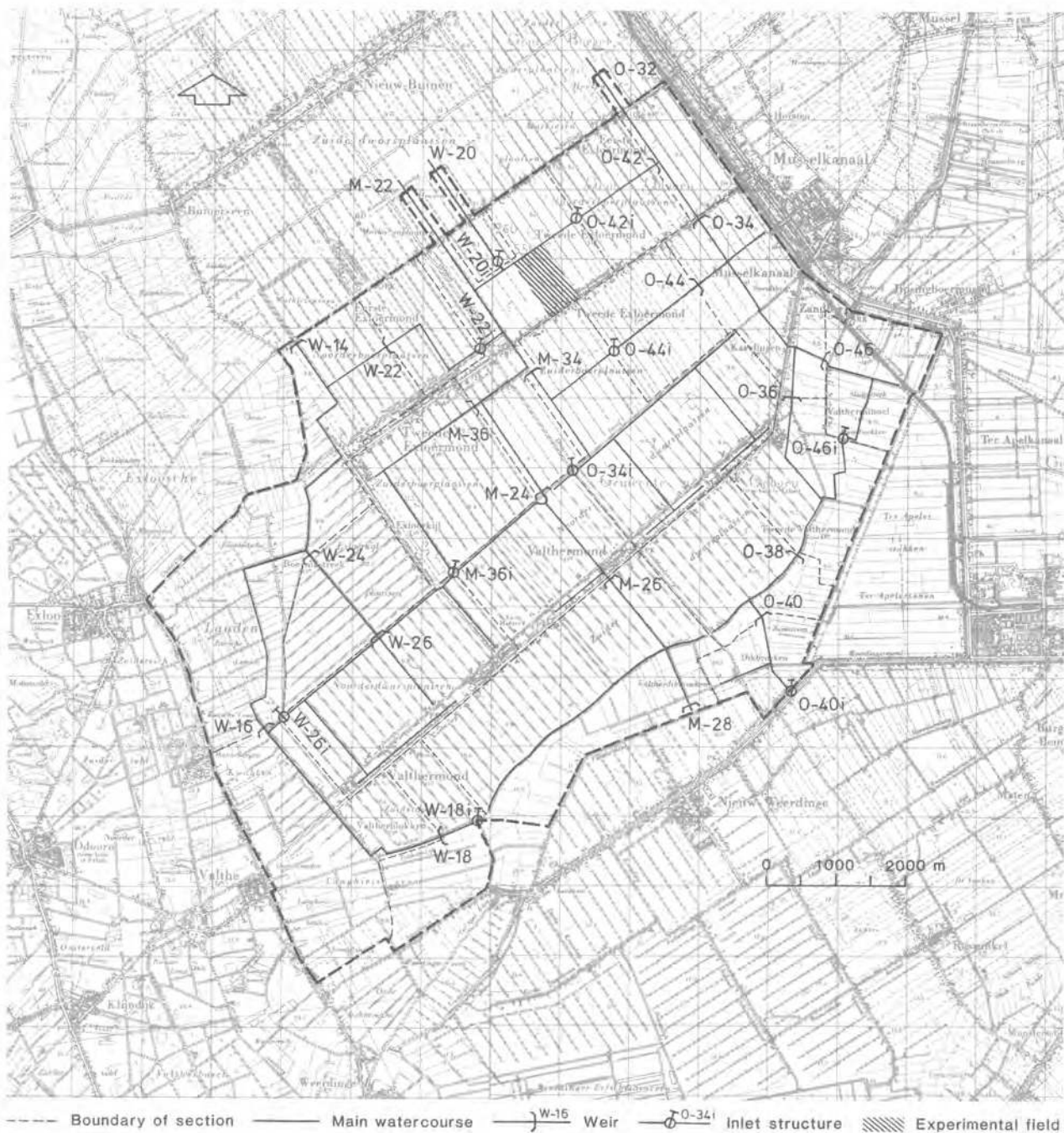

Fig. 3.9. Structures for water management and sections with the same open water level in the research area 'De Monden'. Letters and numbers refer to sections

4. PHYSICAL-MATHEMATICAL APPROACH

4.1. INTRODUCTION

The most critical points in any hydrological research project are: a) schematization of the hydrological processes involved, b) detection of the key properties of the hydrological system and c) mathematical modeling of the relevant physical processes. Especially for the first two points no strict rules can be given.

In this chapter the above mentioned points will be discussed keeping in mind the objectives of this study. One can try to reach this goal by either performing field experiments or by hydrological modeling. Field experiments are very time consuming, and the results only hold for the circumstances encountered during these experiments. Therefore hydrological modeling is often used as a way out. For this purpose the complex hydrological reality has to be translated into systems.

A perceptual model of the hydrological system under discussion in Forrester notation is given in

Fig. 4.1A for the sub-irrigation situation and in Fig. 4.1B for the drainage situation. From these figures the following sub-systems can be distinguished:

- atmosphere - crop system
- unsaturated groundwater system
- saturated groundwater system
- surface water system

These sub-systems are interrelated through mass (water) flow. To arrive at a solution a mathematical description of each sub-system and of the mass flows interrelating the systems is necessary. In this chapter this problem will be discussed.

4.2. THE ATMOSPHERE - CROP SYSTEM

4.2.1. Physical mathematical backgrounds

The atmosphere may be considered to act as the upper boundary of the hydrological system under con-

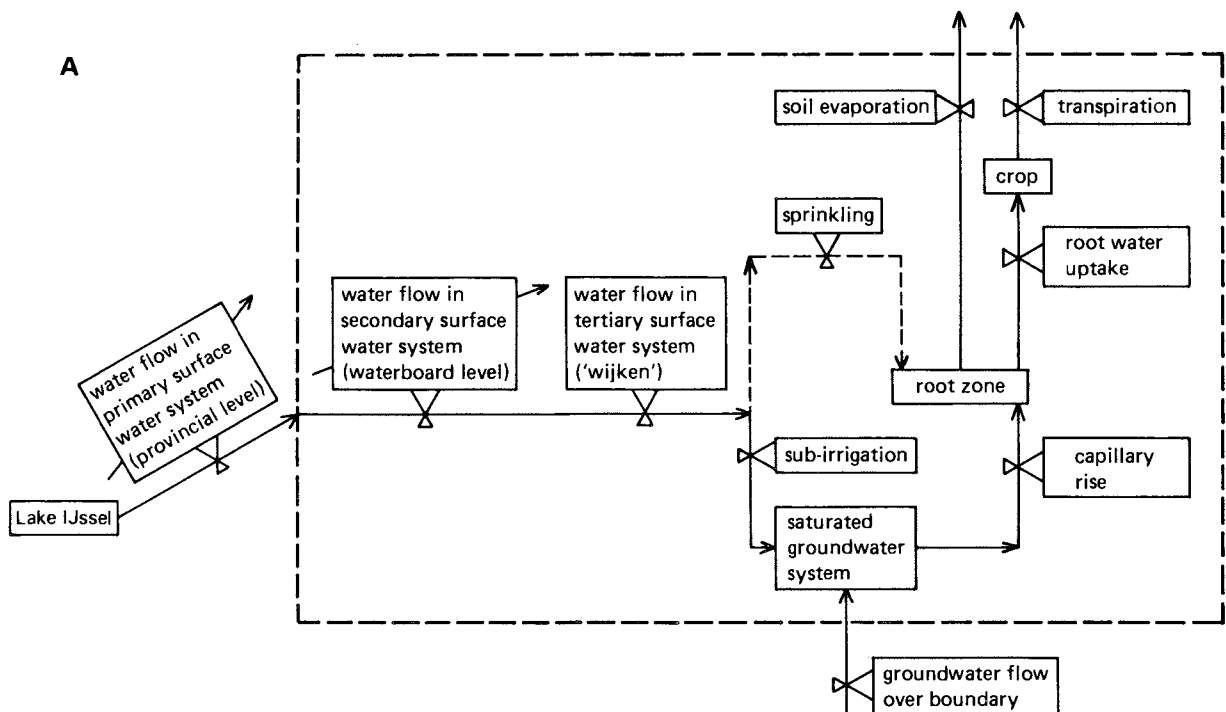

Fig. 4.1A. Perceptual model of the hydrological system for water supply with sub-irrigation situations

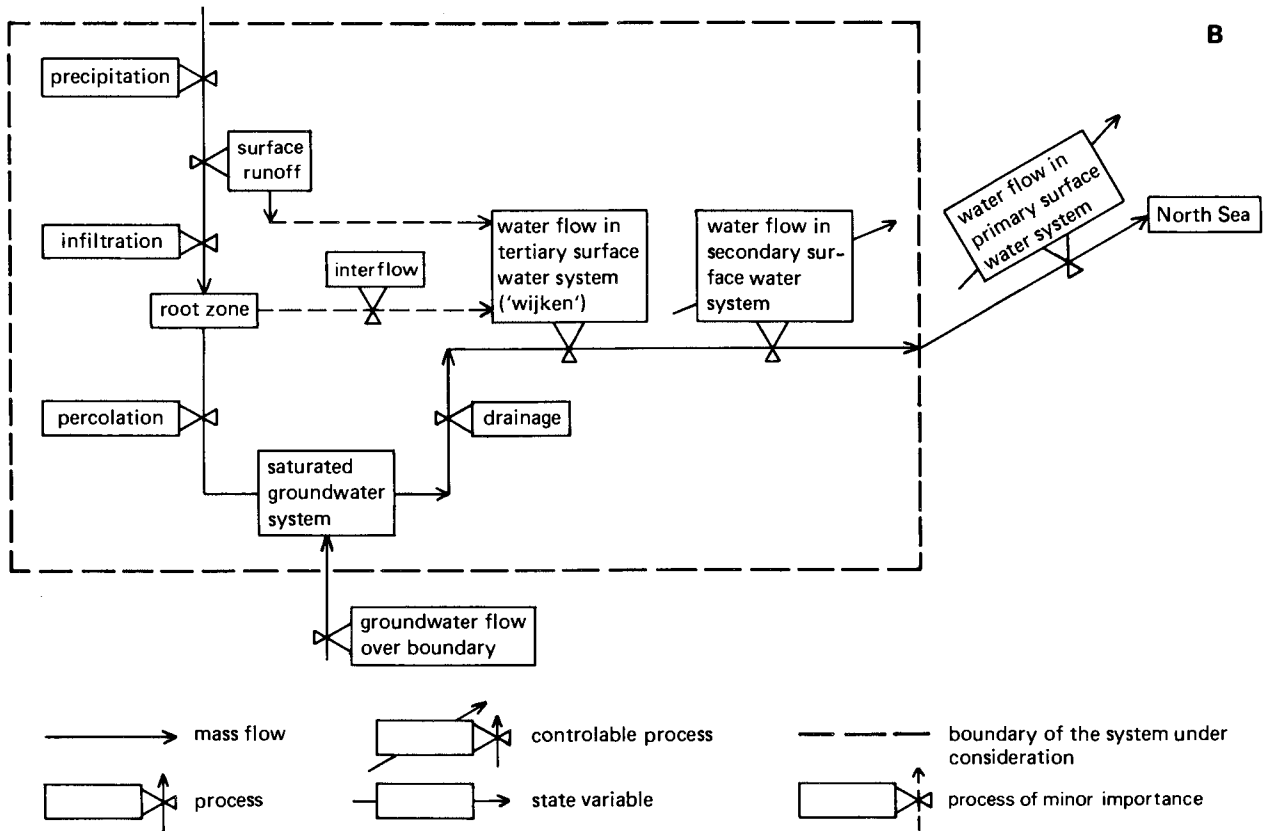

Fig. 4.1B. Perceptual model of the hydrological system for drainage situations

sideration. This means that feedback can be neglected and that the state variables of the atmospheric system are assumed independent of changes in the water management system. For dry climates and large-scale projects this is not true for evapotranspiration (MORTON, 1978), but in the temperate climate of the Netherlands there is no evidence for incorporating a feedback.

The exchange of water between soil surface and atmosphere generally is described by making use of the energy balance. This balance of a surface can be written as:

$$Q^* = G + H + \lambda E \quad (\text{W}\cdot\text{m}^{-2}) \quad (4.1)$$

where Q^* is net radiation flux density, G is soil heat flux density, H is sensible heat flux density, and λE is latent heat flux density. The constant λ is the specific latent heat of vaporization and E is evaporation rate.

For a water surface H and λE can be denoted as:

$$H = c_1(T_s - T_a)/r_a \quad (4.2)$$

$$\lambda E = c_2(e_s - e_a)/r_a \quad (4.3)$$

where c_1 and c_2 are constants, T_s and T_a the temperature at the water surface and in the air at screen height respectively, e_s the saturation water vapour pressure at the water surface, e_a is the water vapour pressure at screen height and r_a is the aerodynamic resistance.

From eqs. (4.1), (4.2) and (4.3) PENMAN (1948) derived the well-known combination equation for open water evaporation:

$$E_o = \frac{s(Q^* - G)/\lambda + \gamma E_a}{s + \gamma} \quad (\text{kg}\cdot\text{m}^{-2}\cdot\text{s}^{-1}) \quad (4.4)$$

with

$$E_a = \frac{\epsilon \rho_a}{p_a} (e_s - e_a)/r_a \quad (\text{kg}\cdot\text{m}^{-2}\cdot\text{s}^{-1}) \quad (4.5)$$

where s is the slope of the saturation vapour pressure curve, γ is psychrometer constant, ϵ is ratio between molecular weight of water vapour and dry air, ρ_a is density of moist air and p_a is atmospheric pressure.

For modeling purposes there is a preference to express evaporation as a volume flux, hence:

$$E_{\text{vol}} = E_{\text{mass}}/\rho_w \quad (4.6)$$

where ρ_w is density of water.

For E_{vol} expressed in $mm \cdot d^{-1}$ one has:

$$E_{vol} = E_{mass} / (\rho_w \times 86.4) \quad (4.7)$$

The transpiration by crops mainly takes place via the stomata, which causes an additional resistance to r_a , often denoted as the canopy resistance, r_c . Incorporating r_c in the Penman equation leads to an equation for any given cropped surface (MONTEITH, 1965; RIJTEMA, 1965):

$$E = \frac{s + \gamma}{s + \gamma(1 + r_c/r_a)} E_w \quad (kg \cdot m^{-2} \cdot s^{-1}) \quad (4.8)$$

The symbol E now stands for evapotranspiration rate and E_w for the evaporation rate of a wet surface. The magnitude of E_w can be computed with eqs. (4.4) and (4.5) by substituting proper values for Q^* and r_a .

In case soil water conditions have no influence on E , it is defined as potential evapotranspiration, E_p . For computation of E_p only meteorological data and values of r_c are required.

The crop is operating 'actively' in the transpiration process because the behaviour of the stomata and consequently r_c is influenced by soil water status and atmospheric demand (MONTEITH, 1975; SLATYER, 1967). A model that takes into account changes in the heat balance of the crop surface caused by changes in water supply by the root zone, has been developed by SOER (1977). In this model energy balance equations are solved in an iterative way. Although the crop is modeled as a single-layer one, the model still needs data for time periods less than one hour and is therefore less suitable for use in water management models.

A more indirect feedback mechanism is that crops show a reduction in growth when transpiration is reduced. By detailed modeling of growth processes it is in principle possible to take into account this form of feedback. The changes in crop physiology and hence morphology are slight and in this study they will be considered independent of the soil water status.

For evaporation from a wet soil eqs. (4.4) and (4.5) can be applied, taking into account the roughness of the soil surface and the soil cover fraction, S_c . The evaporation from a dry soil is governed by the atmospheric demand and the hydraulic conductivity of the upper few centimeters of the soil. The mathematical description of this process is so complicated (MIGNETTI, 1982) that it is difficult to use it in hydrological models. Therefore a parametrical approach has been followed to obtain a solution (see Chapter 5).

4.2.2. Boundaries of the atmosphere - crop system

In order to be able to describe the exchange of water between the atmosphere - crop system and the groundwater system one has to take into account the following processes:

- interception of rainfall
- infiltration
- surface runoff
- water uptake by roots

Part of the rainfall P is intercepted by the crop cover. The amount of intercepted water depends on both soil cover and precipitation rate. An empirical relation has been given by BELMANS et al. (1983). Evaporation of intercepted water can be derived from eqs. (4.4) and (4.5).

The actual infiltration rate, f_i , is calculated as:

$$f_i = P_n \text{ if } f_i \leq f_p \quad (4.9)$$

$$f_i = f_p \text{ if } f_i > f_p \quad (4.10)$$

where f_p is maximum possible infiltration rate ($mm \cdot d^{-1}$) and P_n is net precipitation, to be calculated as:

$$P_n = P - E_i \quad (4.11)$$

where E_i is the evaporation rate of intercepted water.

Neglecting the storage of water on the soil surface, the surface runoff, f_r , is calculated as:

$$f_r = 0 \quad \text{if } f_i \leq f_p \quad (4.12)$$

$$f_r = P_n - f_p \text{ if } f_i > f_p \quad (4.13)$$

The water uptake by plant roots is strongly influenced by soil water conditions in the root zone. This process will be dealt with in more detail in Paragraph 4.3.3.

4.2.3. Meteorological and crop data

At an experimental site of which the location is given in Fig. 3.8 the meteorological data: wind speed, precipitation, net radiation, air temperature and relative humidity were recorded continuously during the years 1980 and 1981. In order to obtain data for other years, these recordings (except for precipitation) were averaged per day and compared with corresponding measurements at the main meteorological station Eelde, some 40 km northwest of the pilot area. The parameters a_1 , b_1 and r^2 of the linear regression

Table 4.1. Parameters in the linear regression equation $y = a_1x + b_1$, relating meteorological data measured in 'De Monden' (y) with data of Eelde (x). Values between brackets hold when y should have been measured in Eelde

	a_1	b_1	r^2	Number of data
Wind speed ($m \cdot s^{-1}$)	0.61 (0.72)	0.53 (0.0)	0.83	252
Temperature ($^{\circ}C$)	1.01 (1.00)	-0.21 (0.0)	0.99	191
Relative humidity (%)	1.01 (1.00)	-3.3 (0.0)	0.89	589
Net radiation ($J \cdot cm^{-2} \cdot d^{-1}$)	0.476 (0.52)	52 (52.0)	0.91	127

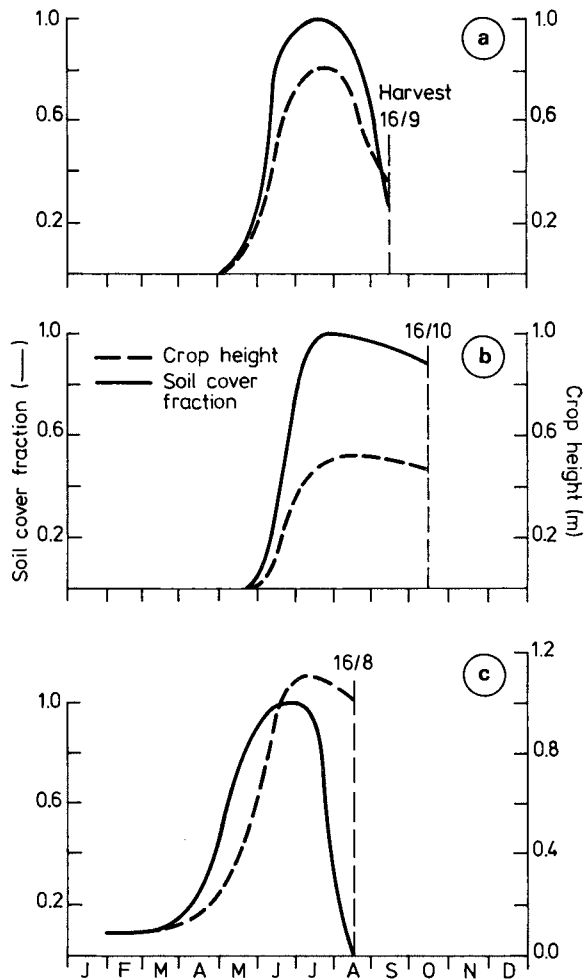

Fig. 4.2. Average course in time of soil cover fraction and crop height of potatoes (a), sugar beets (b) and winter wheat (c)

equation:

$$y = a_1x + b_1 \quad (4.14)$$

where y stands for the data in the pilot area and x for the corresponding data for Eelde are given in Table 4.1. It should be remarked that the surface cover in 'De Monden' was different from that in Eelde.

On the same experimental site data on crop growth of potatoes, sugar beets and winter wheat were collected during the period 1978-1981. On the average once

per 3 weeks during the growing season the following data were collected: soil cover, crop height, leaf area index, rooting depth, total dry matter production and dry matter production of harvestable parts. From these data the soil cover fraction and crop height of potatoes, winter wheat and sugar beets during the growing season were derived (Fig. 4.2).

4.3. THE UNSATURATED ZONE

For crop growth the sub-system of the unsaturated zone is the most important. Being only interested in (changes in) water uptake secondary effects like changes in nutrient uptake are neglected in this study.

4.3.1. General theory

For each soil there exists a relation between the pressure head, h_p (cm), and the soil water content, θ ($m^3 \cdot m^{-3}$), so:

$$\theta = f(h_p) \quad (4.15)$$

Flow of water in the unsaturated zone of importance for the problem under discussion is restricted to vertical upward and downward flow only. These types of flow can be described by the one-dimensional differential equation:

$$\frac{\delta \theta}{\delta t} = \frac{\delta}{\delta z} \left[K(h_p) \left(\frac{\delta h_p}{\delta z} + 1 \right) \right] - S \quad (4.16)$$

where S is a 'sink' term representing water uptake by plant roots. Hysteresis was neglected because the most important is drying out of the soil during the growing season.

4.3.2. Boundaries of the unsaturated zone

The 'upper' boundary of the unsaturated zone system is the atmosphere - crop system. The rate of water uptake equals the rate of transpiration. The actual rate of transpiration can be calculated from:

$$E_t = \int_0^{z_r} S dz \quad \text{if } E_t < E_{t,p} \quad (4.17)$$

$$E_t = E_{t,p} \text{ if } E_t > E_{t,p} \quad (4.18)$$

where z_r is rooting depth, S the volume of water taken up by the roots per unit volume of soil per unit time and $E_{t,p}$ is potential transpiration rate, FEDDES et al. (1978) consider the sink term S as a function of the pressure head in the root zone, so $S = f(h_p)$.

The 'lower' boundary of the unsaturated zone is the phreatic surface. The position of this surface is varying with time. In the next chapter the way this problem was solved, will be elaborated.

4.3.3. Soil physical properties

For a mathematical description of water movement in the unsaturated zone information is needed about soil water retention and hydraulic conductivity. BOUMA and Van HEESSEN (1981) showed that for sandy soils a regular soil map can be used for a soil physical classification.

For the research area the following procedure for determining soil physical properties was followed. On the basis of the available soil map 12 sampling spots were selected. At each spot per layer separate samples for the determination of retention curves, hydraulic conductivity curves and granular composition were collected. Measuring of the soil physical properties was performed in the laboratory. Water retention curves were determined with the method described by STAKMAN et al. (1969). The determination of the $K(h_p)$ -relationships was done by the evaporation method (BOELS et al., 1978), the computation method based on texture and organic matter content (BLOEMEN, 1980a,b) and the computation method of BROOKS and COREY (1964).

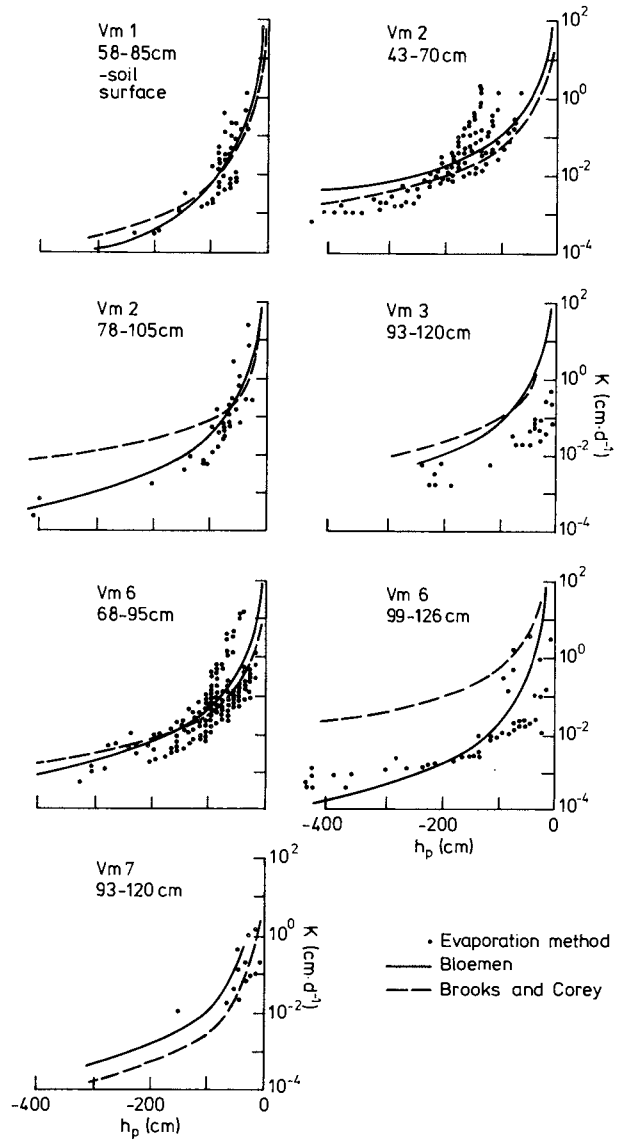

Fig. 4.3. $K(h_p)$ -relations for sandy layers obtained with three different methods

Table 4.2. Soil physical properties of the different layers distinguished in the research area 'De Monden' (ρ_s is density of soil)

Number soil layer	Description	Volume water content (θ) at h_p (m) =									Parameters in eq. (4.19)		
		0.00	-0.10	-0.32	-0.63	-1.00	-2.00	-5.00	-25.00	-160.00	$0.5K_s$ ($m \cdot d^{-1}$)	h_a/r (m)	n_s (-)
1	root zone: <15% org. matter	48.9	47.4	45.8	44.0	41.6	36.4	28.8	19.3	14.1			
2	15-20% org. matter	57.4	54.4	52.5	50.4	48.2	44.1	37.0	22.9	16.3	0.86	0.075	1.46
3	>20% org. matter	64.0	60.0	57.1	54.0	50.9	46.3	39.3	24.7	17.7			
4	fen peat $\rho_s = 230 \text{ kg} \cdot \text{m}^{-3}$	88.4	86.4	82.6	78.5	75.2	69.5	57.2	35.5	22.3	0.0026	0.260	1.62
5	$\rho_s = 250 \text{ kg} \cdot \text{m}^{-3}$	78.5	75.5	68.0	63.1	59.8	54.4	46.5	32.7	24.4	0.00185	0.35	1.57
6	white loose peat $\rho_s = 140 \text{ kg} \cdot \text{m}^{-3}$	89.8	82.8	77.3	70.8	66.0	58.7	50.1	26.4	16.4	0.0044	0.24	1.86
7	high bog peat $\rho_s = 170 \text{ kg} \cdot \text{m}^{-3}$	85.0	82.0	77.9	74.3	68.9	62.0	54.0	33.7	22.3	0.0026	0.26	1.62
8	fossile O-horizon	85.6	83.6	81.4	81.0	79.7	76.9	72.1	42.0	26.8	0.0145	0.48	1.41
9	Lacustrine organic-mineral mud	46.6	45.6	44.9	44.1	43.2	41.6	39.2	28.9	14.8	0.0282	0.27	1.41
10	highly loamy sand	40.2	37.7	36.1	34.0	31.6	27.2	22.5	15.7	8.4	0.57	0.08	1.81
11	medium loamy sand I										0.77	0.07	2.62
12	medium loamy sand II	37.8	34.5	31.8	27.6	21.1	16.1	9.4	7.7	4.1	0.80	0.06	2.20
13	medium loamy sand III										0.80	0.08	3.67
14	slightly loamy sand I										0.90	0.07	3.46
15	slightly loamy sand II	35.0	32.0	29.9	26.0	19.3	12.4	8.0	4.2	2.5	1.05	0.06	3.22

Table 4.3. Soil physical properties of soil physical units changed by soil improvement (between brackets the corresponding mapping units of Soil Map 1:50 000)

Soil physical unit	Depth (cm below soil surface)	Volum. water content (θ) at h_p (m) =									Parameters in eq. (4.19)		
		0.00	-0.10	-0.32	-0.63	-0.100	-0.200	-0.500	-25.00	-160.00	$0.5K_s$ ($m \cdot d^{-1}$)	h_a/r (m)	n_s (-)
IX (iVz, iVp)	0- 40	68.5	63.5	60.3	56.6	52.6	47.5	38.5	24.5	16.0	0.49	0.06	1.48
	40- 80	70.9	66.9	63.2	58.9	53.8	48.0	40.6	24.1	15.2	0.23	0.08	2.16
	80-120	58.5	56.0	51.9	49.4	44.0	38.6	31.7	20.4	12.8	0.37	0.06	2.22
	>120	37.8	34.5	31.8	27.6	21.1	16.1	9.4	7.7	4.1	0.80	0.08	3.67
X (iWz, zWz)	0- 40	60.3	57.3	53.1	49.5	45.8	41.0	33.7	22.8	16.3	0.52	0.06	1.47
	40- 65	48.2	45.5	42.5	39.3	35.4	31.1	25.4	18.5	11.2	0.42	0.04	1.62
	65- 90	46.4	43.2	39.9	36.0	30.9	26.0	19.4	14.3	9.0	0.50	0.04	1.82
	>90	37.8	34.5	31.8	27.6	21.1	16.1	9.4	7.7	4.1	0.80	0.08	3.67
XI (iWp)	0- 40	57.6	54.6	51.2	47.9	44.3	39.7	32.5	21.6	15.3	0.59	0.07	1.48
	40- 90	55.5	52.4	49.0	45.4	40.6	35.9	29.4	19.6	12.7	0.40	0.07	2.22
	>90	37.8	34.5	31.8	27.6	21.1	16.1	9.4	7.7	4.1	0.80	0.08	3.67

Because of failures during the laboratory tests, comparison of results obtained with the different methods could be carried out only for a limited number of data. In Fig. 4.3 data for sandy layers are shown. For peaty layers the evaporation method did not work at all. For sandy layers (less than 30% organic matter) the method of Bloemen gave results which are close to measured data. Because for each sampled layer soil texture and organic matter content were known, it was possible to establish a $K(h_p)$ -relationship by means of this method. The results, together with data on water retention are given in Table 4.2. The parameters given in the table refer to the equation

$$K(h_p) = 0.5K_s \left(\frac{h_a}{r \cdot h_p} \right)^{n_s} \quad (4.19)$$

where K_s is saturated hydraulic conductivity, h_a is air entry pressure head and r is a factor for hysteresis (BLOEMEN, 1980a,b).

Next the sequence of these layers for each soil type of the soil map 1:50 000 was established. Mapping units that showed similar sequences were combined and in this way the soil physical properties of the whole area could be classified in 8 soil physical units.

By soil improvement soil layers with different soil physical properties are created. In soil mapping soil improvement, except sand dressing, was not included. As was indicated in the previous chapter, soil improvement has been applied on a large area. Therefore its soil physical consequences must be estimated. The retention curve for these mixed soils

was determined from the weighted average of properties of the original layers. For the $K(h_p)$ -relationship this is somewhat more complicated. BLOEMEN (1982) quantified these changes by calculating the weighted average hydraulic conductivity of the original layers for different h_p . Next he computed organic matter content and textural analysis on the basis of the properties of the original layers and with these data parameters were derived by curve fitting. This procedure was applied to those soil types that were potentially improvable. In Table 4.3 the resulting soil physical properties of three improved physical units are given.

When discussing model verification and sensitivity analyses, more will be said about the uncertainties in soil physical properties.

4.4. THE SATURATED GROUNDWATER SYSTEM

4.4.1. Mathematical background

Flow of water in the saturated zone can be described by the general three-dimensional differential equation:

$$S_s \frac{\delta h}{\delta t} = \frac{\delta}{\delta x} \left(K_x \frac{\delta h}{\delta x} \right) + \frac{\delta}{\delta y} \left(K_y \frac{\delta h}{\delta y} \right) + \frac{\delta}{\delta z} \left(K_z \frac{\delta h}{\delta z} \right) - q \quad (4.20)$$

where S_s is the volume of water stored per unit volume of soil per unit change in head h and q represents the extraction rate of water.

If the water flow in a groundwater basin is schematized as horizontal flow in permeable layers (aquifers) and vertical flow in layers with low permeability (aquitards), a simplification of the general flow equation is possible. In a confined aquifer eq. (4.20) becomes:

$$S_a \frac{\delta h}{\delta t} = \frac{\delta}{\delta x} (K_x D \frac{\delta h}{\delta x}) + \frac{\delta}{\delta y} (K_y D \frac{\delta h}{\delta y}) - qD \quad (4.21)$$

where D is thickness of aquifer and S_a is volume of water stored per unit area per unit change in head.

In an aquitard, eq. (4.20) becomes:

$$S_s \frac{\delta h}{\delta t} = \frac{\delta}{\delta z} (K_z \frac{\delta h}{\delta z}) - q \quad (4.22)$$

With the given equations the groundwater flow can be calculated when the parameters in these equations and the boundary conditions of the problem are known.

4.4.2. Boundaries of the saturated system

The upper boundary of the saturated system is formed by the phreatic groundwater table, except when there is a perched water table. In steady-state situations, the flux through this boundary, v_f , can be derived from the water balance of the unsaturated zone; in nonsteady situations, v_f is varying in time and difficult to determine.

In the area under consideration water will also flow laterally through the external boundaries. Therefore hydrological measures in the area itself as well as measures outside the area can influence the loss or gain. In order to account for this flow a specification of the boundary conditions is necessary. This can be done in three different ways:

- by the Dirichlet condition: the pressure head at the boundary is specified as a function of time

$$h(x_B, y_B, t) = h_B(t) \quad (4.23)$$

- by the Neuman condition: the flux is specified as function of time

$$v(x_B, y_B, t) = v_B(t) \quad (4.24)$$

- by the Cauchy condition: the flux is a function of the hydraulic head

$$v(x_B, y_B, t) = f(h_B) \quad (4.25)$$

Because open water levels in the various sections of the area are different, a number of internal boundaries of the saturated system has to be distinguished.

The mass flow through these boundaries will be described in detail in Paragraph 4.6.1.

4.4.3. Geo-hydrological schematization

Quantification of the flow in the groundwater system requires that the soil profile is divided into aquifers and aquitards. This is done on the basis of the geological information described in Chapter 3, additional information on hydrological parameters and on own field research.

The geo-hydrological schematization following from geological information is given in Fig. 4.4, together with a rough indication of KD and c-values, obtained from textural properties of the various layers.

Piezometer observations learned that Holocene deposits, as far as present, are situated in the unsaturated zone so there was no need to distinguish the Holocene deposits as a separate layer in the saturated system.

The upper (phreatic) aquifer is formed by the fine sands of the Twente Formation with a thickness of about 15 m. The K-value varies according to HOOGHOUTT (1943) between 1.3 and $4.5 \text{ m}\cdot\text{d}^{-1}$. Similar values were found in the upper two meters from field measurements with the auger hole method. Using an average value of $3.2 \text{ m}\cdot\text{d}^{-1}$ and taking into account the magnitude of the layer yields the map of the $K_1 D_1$ -values shown in Fig. 4.5.

Below the Twente Formation on some locations continental Eemian is forming a resistive layer. Available well-logs did not allow to deduce a c-value map of this layer. Therefore an indirect method was

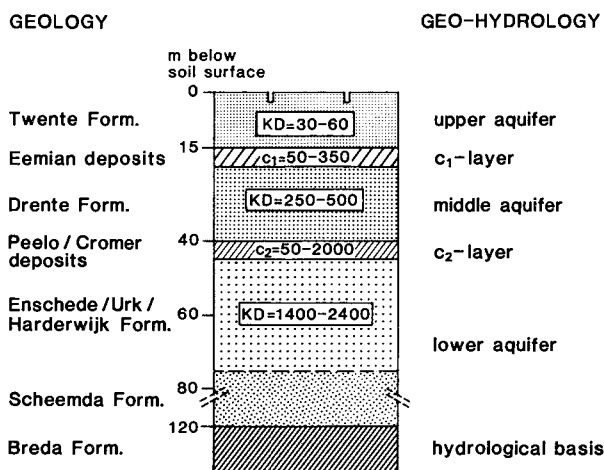

Fig. 4.4. Geo-hydrological schematization based on geological information

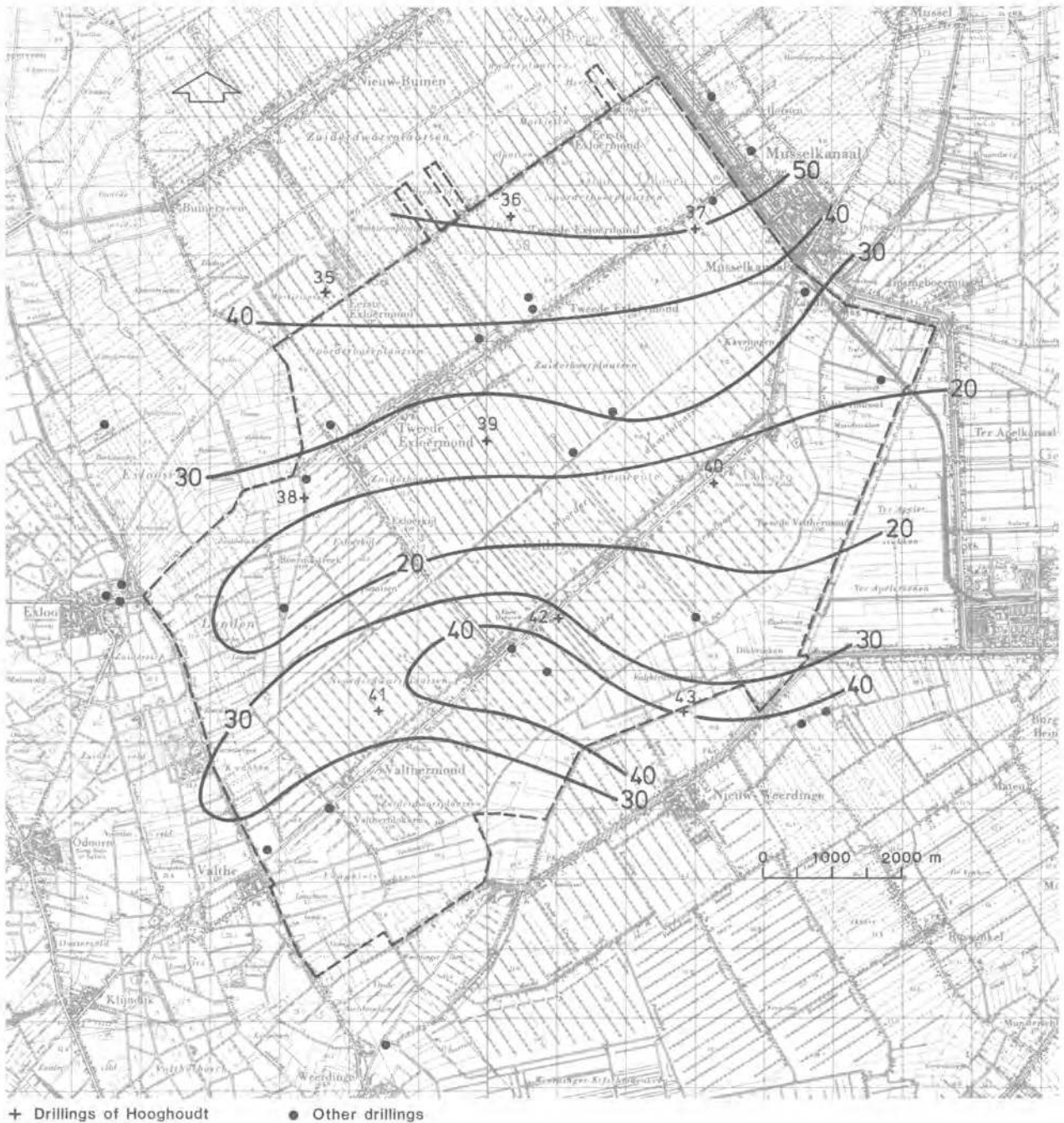

Fig. 4.5. Transmissivity map of the upper aquifer

used. In the research area the hydraulic head in the upper aquifer was measured at 52 places. For monitoring the deeper aquifers at 10 locations piezometers at 20 and 60 m below soil surface were installed. Water balance data for the upper aquifer and differences in hydraulic head resulted in a *c*-value map of the Eemian Formation as given in Fig. 4.6 (an KEULEN, 1982). It should be emphasized that this is only a first estimate, because relatively small errors in measured flows or hydraulic heads result in relatively large

errors in *c*-values.

The middle aquifer consists of coarse material of the Drente Formation. Based on the analysis of 6 borings an average *K*-value of $25 \text{ m}\cdot\text{d}^{-1}$ was established (POMPER, 1981). Together with the thickness of the aquifer as found from these borings, this gave the transmissivity map of Fig. 4.7.

Below the Twente Formation fine clayey sands and clays of the Peelo Formation were found. Direct determination of the *c*-value of this layer was not

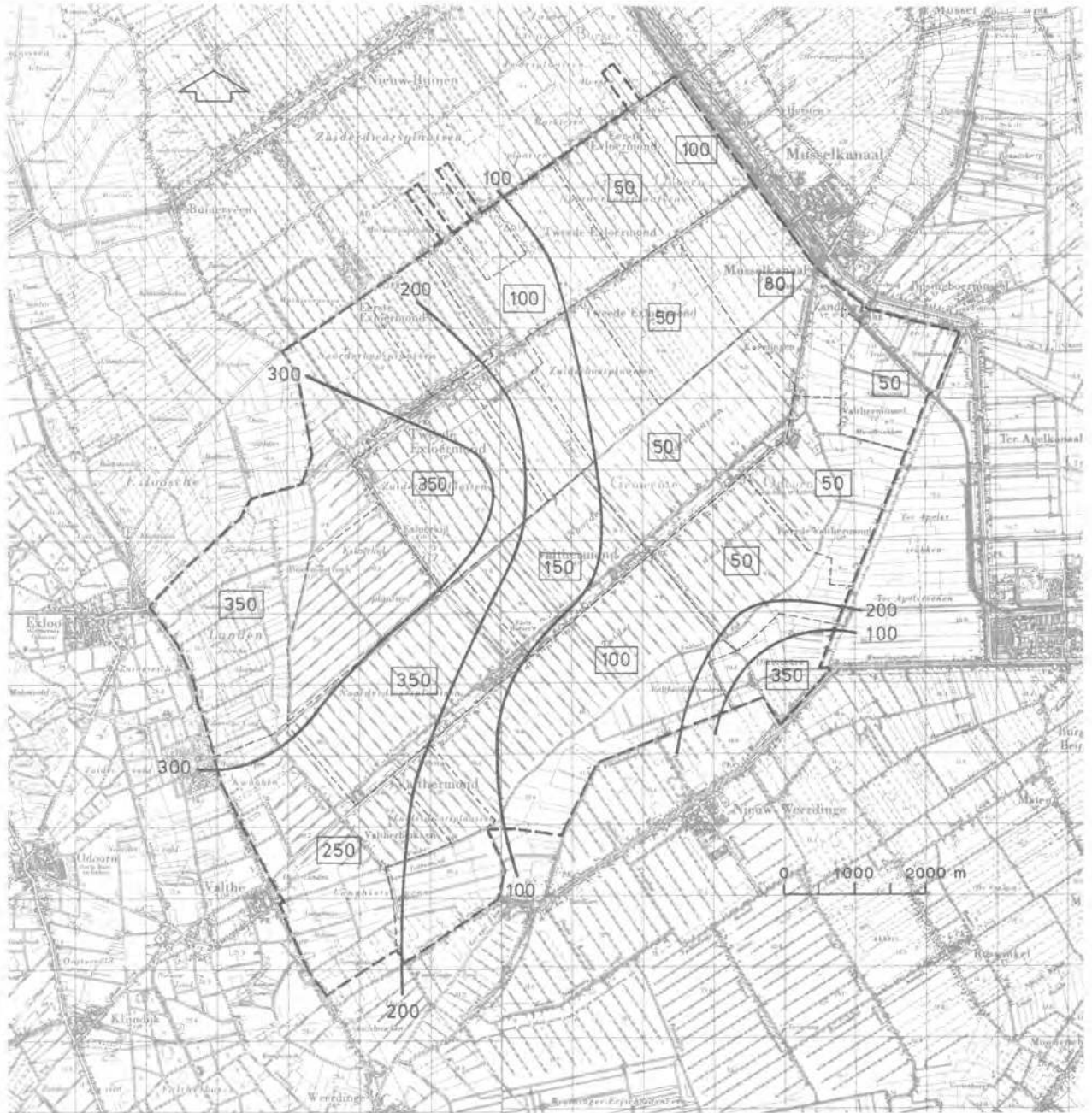

— 100 Isolines of $c_1=100$ days [100] Mean c_1 -value per section

Fig. 4.6. Values of the vertical resistance c_1 of the aquitard below the upper and middle aquifer as derived from water balance data and observed head differences

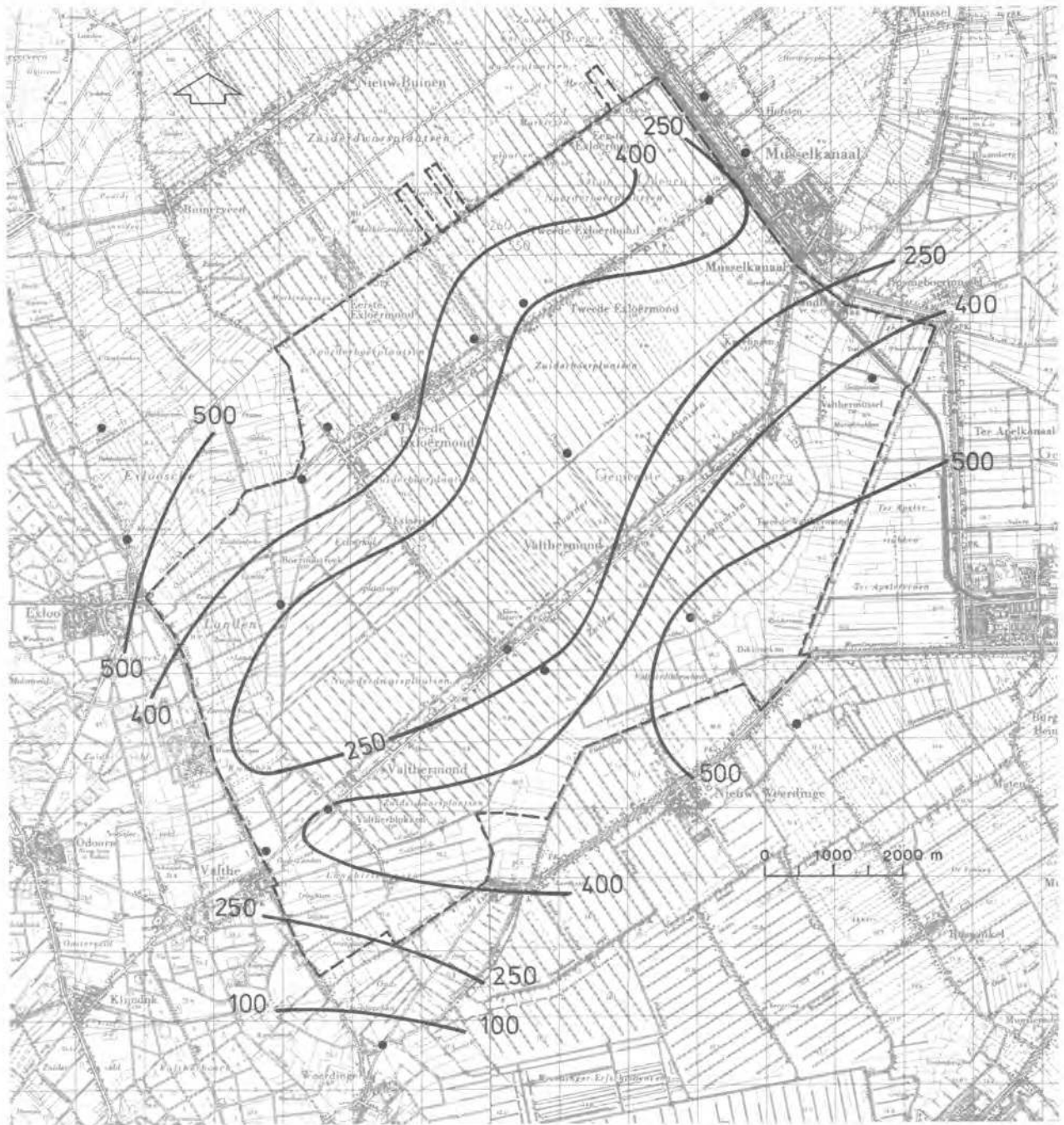

Fig. 4.7. Transmissivity map of the middle aquifer as derived from borings

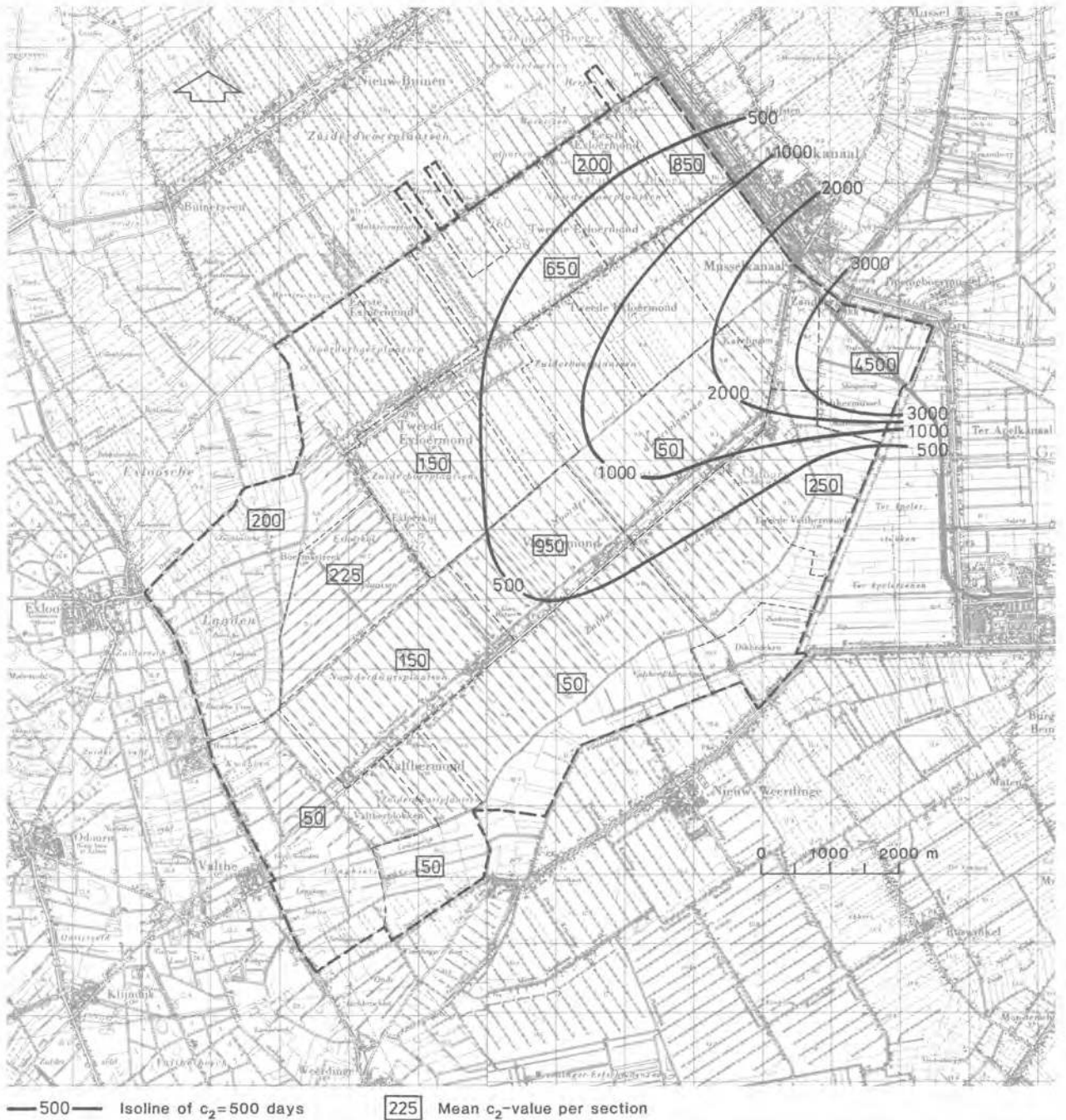

Fig. 4.8. Vertical resistances of the aquitard between the middle and lower aquifer as derived from water balance data and observed head differences

possible. The same procedure as applied for the Eemian Formation resulted in a first estimate of the c_2 -value of this aquitard given in Fig. 4.8.

The lower aquifer, formed by coarse old Pleistocene material of the Formations of Urk, Enschede and Harderwijk, is the most important aquifer, the transmissivity of which is shown in Fig. 4.9 (POMPER, 1981). The basis of the saturated system is formed by the clays of the Tertiary Breda Formation.

Data on the storage coefficient S_a of the different layers are very scarce. From the analysis of a pumping test, a value of 2.75×10^{-4} for the lower aquifer has been derived (POMPER, 1981). The thickness of this aquifer being approximately 60 m, this results in a value for the specific storativity of about $5.0 \times 10^{-6} \text{ m}^{-1}$. Taking a total thickness of all aquifers of 120 m and a maximum difference in hydraulic head of 2 m, the storage capacity in the saturat-

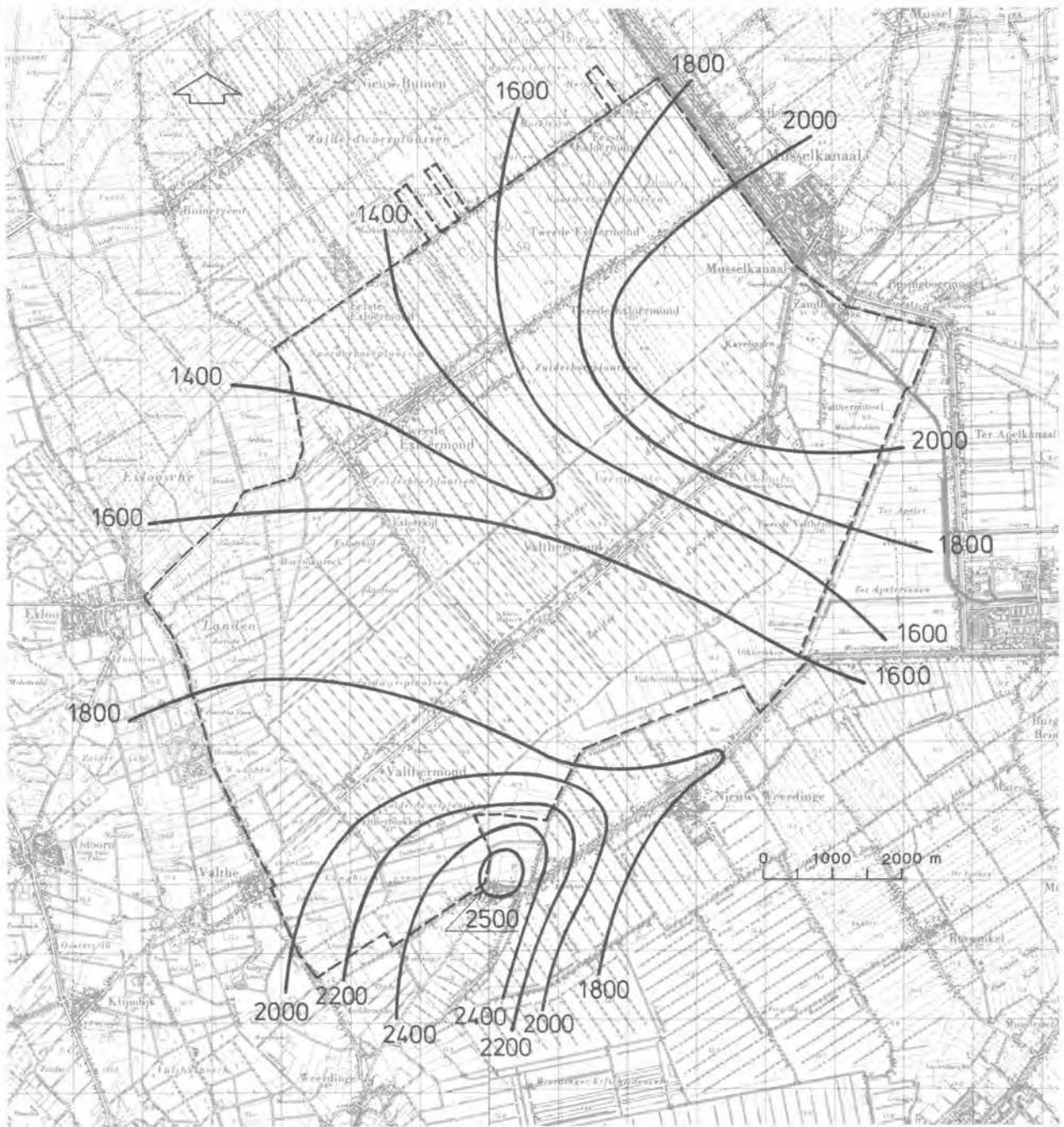

Fig. 4.9. Transmissivity map of the lower aquifer (after Pomper, 1981)

ed system is in the order of 1.2×10^{-3} m, a value two orders of magnitude lower than the phreatic storage coefficient of about 0.10. Therefore the storage properties of the middle and lower aquifer as well as those of the aquitards in between can be safely neglected.

4.5. THE SURFACE WATER SYSTEM

4.5.1. Water flow in open watercourses and over weirs

The water flow in open watercourses can be described by the following equations:

- equation of motion (Saint-Venant)

$$\frac{\delta Q}{\delta X} + \frac{\delta}{\delta X} \left(\alpha_V \frac{Q^2}{A_W} \right) + g A_W \frac{\delta y}{\delta X} + g A_W S_e = 0 \quad (4.26)$$

- continuity equation

$$\frac{\delta Q}{\delta x} + \frac{\delta A_w}{\delta t} = 0 \quad (4.27)$$

where Q is discharge, y is water depth, A_w is wetted area, α_v is coefficient depending on velocity distribution and S_e is slope of energy line, H_e .

The energy line can be split into:

$$H_e = \frac{\overline{v_{f1}}^2}{2g} + P_e/\rho_w g + z \quad (4.28)$$

where $\overline{v_{f1}}$ is average fluid velocity, P_e is pressure energy per unit of volume and ρ_w is density of water.

The slope of the energy line is the result of the slope of the bottom of the watercourse, S_o , and a loss of head caused by the friction resistance, S_f , so:

$$S_e = S_o + S_f \quad (4.29)$$

S_f can be calculated with the empirical Manning equation:

$$S_f = \frac{n_M^2 Q^2}{R^{4/3} A_w^2} \quad (4.30)$$

where n_M is the roughness coefficient of Manning and R is hydraulic radius. The value $1/n_M$ is often referred to as the conveyance factor K_M . The value of K_M depends on the roughness of the walls of the watercourse and, consequently, on the presence and type of water weeds. The parameter K_M sometimes is expressed as a function of water depth (WERKGROEP AFVOERBEREKENINGEN, 1979):

$$K_M = \gamma h^\delta \quad (4.31)$$

with δ is about 0.33 and γ is depending on the state of maintenance of the watercourse.

The flow rate Q over a broad-crested weir with a depth of flow equal to the critical depth, y_c , (Fig. 4.10) can be calculated from:

$$Q = C_d C_v \left(\frac{2}{3}\right)^{0.50} b h_1^{1.50} \quad (4.32)$$

where C_d is a dimensionless discharge coefficient to account for viscous effects, increased turbulence and non-uniform velocity distribution, C_v is an approach velocity coefficient to account for the velocity head in the approach channel, b is effective width of the weir, and h_1 is upstream head above crest. For the determination of C_d and C_v tables are available (BOS, 1976).

For any particular weir the stage discharge relation between discharge q and upstream head h_1 can be written as:

$$q' = C_d' h_1^n \quad (4.33)$$

where q' is discharge per unit width, C_d' is discharge coefficient and n is a constant. In the present study this equation will be used for weirs and inlet structures.

4.5.2. Hydraulic properties of watercourses and weirs

In the design of the main watercourses, permissible backwater effects in each section have been taken into account (Table 4.4). During water supply the flow volumes are below or equal to $2.5 \text{ mm}\cdot\text{d}^{-1}$, so that the main watercourses are oversized for water supply and backwater effects can be neglected.

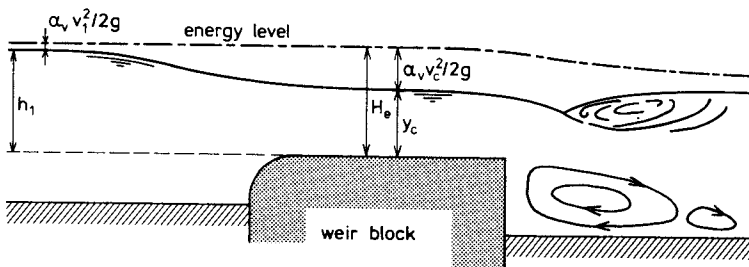

Fig. 4.10. Flow pattern over a broad-crested weir (after Bos, 1976)

	Section								
	W-14	W-16	W-24	M-22	M-24	M-28	O-32	O-36	O-38
Backwater effect	1.00	0.60	0.40	0.70	0.30	0.65	0.45	0.55	0.40

Table 4.4. Backwater effects (m) in a number of sections at a discharge intensity of $10 \text{ mm}\cdot\text{d}^{-1}$ as taken into account for the design

Table 4.5. Parameters for the different weirs and inlet structures in 'De Monden' (for location see Fig. 3.8) and ranges of h_1 (cm) for which they are valid

Number	C_d'	b(m)	n	h_1 -range
W-14 winter	1.88	4.28	1.595	
summer	2.17	4.28	1.50	
W-16	1.67	3.00	1.5	<3.0
	1.76	3.00	1.5	3.0 - 8.0
	1.79	3.00	1.5	>8.0
W-18, W-22, W-24	0.205	1.30	3.5	<2.5
W-26	0.815	1.35	2.00	2.5 - 6.0
	1.817	1.40	1.53	>6.0
W-20	1.600	1.40	1.50	
M-22 winter	1.88	4.76	1.595	
summer	2.17	4.76	1.510	
M-24	0.64	4.28	1.979	
M-26	0.205	4.28	3.50	<2.5
	0.815	4.28	2.00	2.5 - 6.0
	1.87	4.28	1.53	>6.0
M-28	2.716	2.75	1.669	
M-34	0.205	1.50	3.50	<2.5
	0.815	1.50	2.00	2.5 - 6.0
	1.87	1.60	1.53	>6.0
M-36, O-40, O-42	0.205	1.30	3.50	<2.5
O-44, O-46	0.815	1.35	2.00	2.5 - 6.0
	1.87	1.40	1.53	>6.0
O-32 winter	1.88	4.28	1.595	
summer	2.17	4.28	1.510	
O-34	0.22	4.28	3.00	<3.0
	0.85	4.28	1.82	3.0 - 10.0
	2.15	4.28	1.51	>10.0
O-36	0.205	1.75	3.5	<2.5
	0.815	1.75	2.00	2.5 - 6.0
	1.87	1.85	1.53	>6.0
O-38	0.205	1.50	3.50	<2.5
	0.815	1.50	2.00	2.5 - 6.0
	1.87	1.65	1.51	>6.0
W-26i, M-34i	1.67	1.00	1.50	<3.0
M-36i	1.76	1.00	1.50	3.0 - 8.0
	1.79	1.00	1.50	>8.0
O-40i	1.67	1.50	1.5	<3.0
	1.76	1.50	1.5	3.0 - 8.0
	1.79	1.50	1.5	>8.0
O-42i, O-44i,	1.67	0.50	1.5	<3.0
O-46i	1.76	0.50	1.5	3.0 - 8.0
	1.79	0.50	1.5	>8.0
W-22i	pump			

With the exception of W-16 which is broad-crested, all 20 weirs in the main watercourses are sharp-crested. Most weirs have a tooth-shaped crest (Fig. 4.11). When the upstream water head h_1 is below the tops of the teeth, the exponent n in eq. (4.32) depends on both the angles θ_w of the teeth and α_w of the weir itself.

Because the weirs are not constructed for measuring but for regulating purposes, the only way to obtain correct stage discharge relations is to measure in situ. The procedure and results of this field research are described by HOMMA (1981). The resulting discharge formulas have exponents around 1.6.

The 10 inlet structures and W-16 are of the broad-crested Romijn-Vlugter type. Because the stage discharge relation for this type of weirs is accurate-

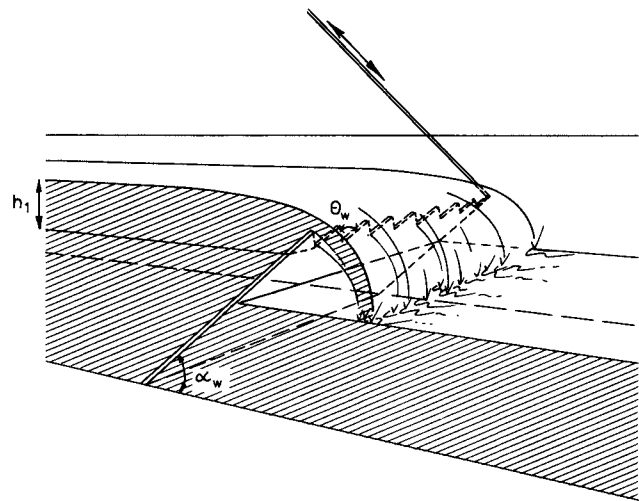

Fig. 4.11. Schematic representation of the flow situation over an adjustable weir with tooth-shaped crest

ly known, no field measurements were needed. A summary of the parameters for the stage discharge relation of all weirs and inlet structures is given in Table 4.5.

The drainage system at farm level is formed by the small canals ('wijken') and main ditches ('zwetsloten') dug during the reclamation process. Application of Manning's formula to well-maintained small canals shows that hardly ever any backwater effect occurs. With the computer program DIWA for permanent discharge (GELOK, 1970) also a situation with heavy growth of water weeds has been analyzed. The lowest known value for $\gamma = 10$ and $\delta = 1/3$ in eq. (4.33) resulted in the empirical relationship:

$$\Delta h_0 = 0.10 v_d^{1/2} \quad (4.34)$$

where Δh_0 is backwater effect in the small canals and v_d flux to these canals. In the field sometimes much higher values were observed (Table 4.6). This discrepancy is due to the presence of sills. Sometimes a too high position of the outflow culvert was observed, but in most cases the bottom of the small canals was raised by the debris of weeds. Because after completion of the reconstruction plan these sills will be removed, such large backwater effects will not occur anymore.

The dimensions of the main ditches are such that some backwater effect under drainage conditions can be expected. Because most of these ditches are filled or will be filled in the near future no attention is paid to the flow process in these ditches.

Table 4.6. Observed and calculated backwater effects in small canals ('wijken') in the period 21 to 23 July 1980. For numbering of sections, see Fig. 3.8

Section	Discharge intensity (mm·d ⁻¹)	Observed Δh_o	Calculated with eq. (4.34)
W-14	7.4	-0.05	0.27
W-16	7.4	0.20	0.27
W-18	8.7	0.13	0.29
W-24	5.1	0.03	0.22
M-22	3.0	0.02	0.17
M-24	4.8	0.13	0.22
M-26	4.0	0.05	0.20
M-28	4.2	0.14	0.20
M-36	2.8	0.28	0.17
O-34	3.2	0.44	0.18
O-36	3.9	0.55	0.20
O-38	4.3	0.34	0.21
O-40	5.2	0.25	0.23

4.6. INTERACTION BETWEEN GROUNDWATER AND SURFACE WATER SYSTEM

4.6.1. Theory

In solving groundwater flow problems a watercourse is a boundary where the hydraulic head is prescribed. In modeling an area it is therefore, in principle, possible to incorporate watercourses as fixed boundaries. Due to their large number, however, this would lead to a very complicated model. In order to get a simpler solution the influence of open watercourses can be replaced by functions describing the relation between flow intensity and difference in head between the open water and the groundwater. One of the possibilities in this respect is the use of the so-called drainage resistance (ERNST, 1954, 1962). According to this author the drainage resistance T for flow between a saturated groundwater system and parallel ditches in a steady-state situation is:

$$T = \frac{h_{f,m} - h_o}{v_f} \quad (4.35)$$

where $h_{f,m}$ is the height of the phreatic surface midway between the ditches, h_o is open water level and v_f is vertical flux density through the phreatic surface.

Sometimes it is more convenient to use:

$$T = \frac{1}{\eta_f} \frac{\bar{h}_f - h_o}{v_f} \quad (4.36)$$

where \bar{h}_f is level of phreatic surface averaged over the area and η_f is a factor depending on the shape of the phreatic surface, defined as:

$$\eta_f = \frac{1}{L} \int_0^L (h_f(z) - h_o) dz \quad (4.37)$$

where L is the distance between watercourses.

The drainage resistance can be split up into four components:

$$T = T_v + T_h + T_r + T_e \quad (4.38)$$

where T_v , T_h , T_r and T_e are vertical, horizontal, radial and entrance resistance, respectively. Each component causes a loss in head proportional to the resistance, so:

$$h_{f,m} - h_o = \Delta h_v + \Delta h_h + \Delta h_r + \Delta h_e \quad (4.39)$$

The loss in head caused by the vertical resistance is (ERNST, 1976):

$$\Delta h_v \approx \frac{v_f}{K} (h_{f,m} - h_o) \quad (4.40)$$

Even with $v_f = 0.01 \text{ m}\cdot\text{d}^{-1}$ the vertical head loss is negligible as long as there are no extreme low permeabilities, say $K_z < 0.5 \text{ m}\cdot\text{d}^{-1}$.

The horizontal resistance is defined as:

$$T_h = \frac{L^2}{\Sigma 8KD} \quad (4.41)$$

The radial resistance T_r for a homogeneous aquifer is (ERNST, 1962):

$$T_r = \frac{L}{\pi K} \ln \frac{4D}{\pi B_w} \quad (4.42)$$

where D is thickness of the aquifer and B_w is wetted perimeter of the watercourse.

Due to deposition of debris and fine material (silt) on the bottom of the drainage canal one can expect an entrance resistance. Little, however, is known about the magnitude of this resistance. Field measurements showed that the part of the side slopes submerged during sub-irrigation has a lower resistance than the bottom. Experiments elsewhere indicate also that the resistance depends on the direction of flow. During sub-irrigation the resistance can increase because of sedimentation of fine particles.

The formulas for the different components of the drainage resistance given above are only valid for certain conditions. In the research area D is at least 15 m. With a variation in the height of the phreatic surface of less than 1.5 m, the assumption

of D being constant is reasonable.

A representative value for B_w of a small canal in the case of drainage and sub-irrigation is 7 and 9 m, respectively. This situation gives a 13% smaller T_r in the case of sub-irrigation. On the other hand a seepage surface may be present above the water level in the canals in the case of drainage causing an increase of B_w .

Because of the above uncertainties, it is better to use actually measured data on drainage resistances. In the next paragraph such data obtained from field measurements on this subject will be dealt with.

4.6.2. Field measurements

Because the small canals ('wijken') form by far the most important part of the drainage system and their mutual distance and geometry is very uniform, one can expect a rather uniform value of T throughout the area. Discharge and open water levels of the different sections and phreatic levels midway between the canals were measured during winter periods 1979/80 and 1980/81. Averaging $h_{f,m}$ and h_o gave a first estimate of T. This resulted, however, in a large variability in T, as is shown in Table 4.7. A better way is to compute T-values for each measured $h_{f,m}$ and h_o separately and to average these T-values. In this way a second estimate of the drainage resistance is obtained, listed as T' in Table 4.7. A drawback of this method is that the obtained data pertain to certain localities only.

Table 4.7. Drainage resistance per section deduced from discharges and groundwater tables

Section	T (from averaging data)	T' (from measurement at one place)	T'' (differential approach)	Best estimate
	(d)	(d)	(d)	(d)
W-14	200	-	-	200
W-16	330	130	90	150
W-18	-	370	-	300
W-24	380	240	180	200
W-26	350	390	350	350
M-22	60	210	90	150
M-24	200	-	150	200
M-26	100	-	50	150
M-34	150	-	150	150
M-36	350	-	180	200
O-32	100	170	90	150
O-34	300	250	300	250
O-36	-	-	300	250
O-38	100	170	-	150
O-40	150	-	170	150
O-42	320	440	400	350
O-44	440	-	-	300
O-46	170	-	-	150

Because the main source of error is the discharge a third method, called the 'differential approach', was applied. To eliminate errors in the discharge measurements it is supposed that the difference in discharge per section in two periods is equal to the difference in effective precipitation in those periods, P_n . The latter is supposed to be known accurately. Implicitly it is assumed that the regional seepage pattern does not change with the effective precipitation. The systematic error in the averaging process was eliminated by taking the difference $\Delta(\overline{h_{f,m}} - \overline{h_o})$ in the two periods considered, so:

$$T'' = \frac{\Delta(\overline{h_{f,m}} - \overline{h_o})}{\Delta P_n} \quad (4.43)$$

A best estimate of the drainage resistance per section has been obtained by assigning weighing factors of 0.4, 0.6 and 1.0 for T, T' and T'', respectively. The results are bounded within preset physical boundaries ($150 \leq T \leq 350$) and rounded off to the nearest 50 (see fourth column of Table 4.7).

No significant differences were found between the area with 'wijken', the area near the southeastern border and the 'sandy' section in the east without 'wijken'. Evidently the behaviour of the drainage system in the latter two areas is comparable with that in the 'wijken' area.

To obtain an insight in the various parts of the drainage resistance detailed measurements in three sub-areas have been made (see WERKGROEP OPSCHONEN WIJKEN, 1982). In the first sub-area the open water level in 4 'wijken', the phreatic levels at 2, 10 and 80 m (denoted as h_1 , h_{10} and h_{80}), the hydraulic heads in the middle and lower aquifer (h_m and h_l respectively) and the discharge from the 'wijken', Q_w , were measured. Because of radial flow in the neighbourhood of the canal, the shape of the phreatic surface between 2 and 10 m from the canal has to be a logarithmic curve. Extrapolation of this curve to the canal wall gives the loss of head due to the entrance resistance, Δh_e .

The distinction between radial resistance T_r and horizontal resistance, T_h , is difficult to make, because of the limited number of measuring points. A conservative estimate of the distance over which radial flow occurs, is 15 m. Neglecting the horizontal resistance in this region means that:

$$\Delta h_r = h_{15} - h_o - \Delta h_e \quad (4.44)$$

The data resulted in the following average values: $T_e = 120$ days, $T_r = 100$ days, $T_h = 20$ days and

Table 4.8. Drainage resistances computed from open water levels and depths of groundwater in two sub-areas, before and after cleaning of 'wijken'

	Before cleaning				After cleaning			
	winter		summer		winter		summer	
	T	T _e	T	T _e	T	T _e	T	T _e
Sub-area 1								
wijk a	-	-	-	2*	175	10	-	.7*
wijk b	-	-	-	3*	188	19	-	8*
wijk c	-	-	-	16*	175	26	-	13*
Sub-area 2								
wijk a	230	28	-	-	-	-	200	26
wijk b	240	22	-	-	-	-	215	13
wijk c	227	36	-	-	-	-	-	18*
wijk d	222	22	-	-	-	-	-	14*

*When T is not given because of lack of discharge data, T_e is expressed in percentage of the total resistance T

T_V = 0. This clearly shows the dominant role of entrance plus radial resistance. The average value for η_F (eq. 4.37) is therefore also very high, viz. 0.9.

In the other two sub-areas groundwater depth and discharge measurements were carried out during 1981 and 1982 in order to investigate the effect of cleaning of 'wijken' on the magnitude of the drainage resistance and the difference between drainage and sub-irrigation conditions. In these areas piezometers were placed in two rows (1/4 and 3/4 from the outlet of the 'wijken') at distances of 1, 3, 5, 10, 20 and 80 m. From the data values for T_e, T_R and T_h have been derived as described above (Table 4.8). On the basis of these data the following conclusions can be drawn:

- the value of T_e is not significantly influenced by cleaning and is in the order of 5 to 15% of the total resistance;
- resistances under sub-irrigation are approximately 10% lower than those under drainage conditions which can be explained by the larger value of the wetted perimeter;
- the total resistance did not increase during a sub-irrigation period of about 5 months. This does not confirm with the idea that under sub-irrigation conditions the resistance increases due to sedimentation of fine material;
- the shape of the phreatic level near the canals can be described very well by a logarithmic curve;
- the shape factor, η_F, of the phreatic level varies between 0.73 and 0.80, for both drainage and sub-irrigation situation. The theoretical value for a radial flow with r₀ = 4 m and T_e = 0.1 T_R is 0.78;
- the shape factor does not depend significantly on the direction of flow. This indicates that the radial re-

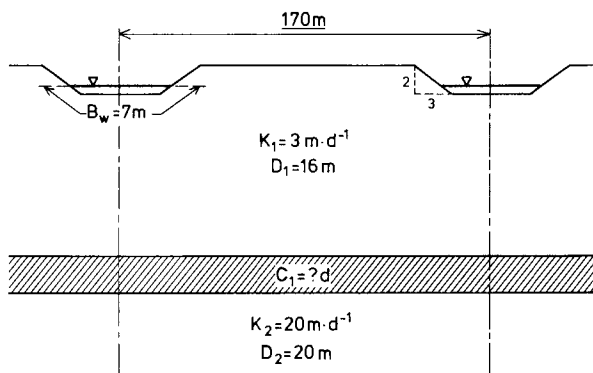

Fig. 4.12. Representative cross-section for the drainage situation

sistance is rather indifferent to variations in direction of flow as indicated by ERNST (1962).

Based on the geo-hydrological situation a representative cross-section for the drainage situation is depicted in Fig. 4.12. When the vertical resistance of the c₁-layer is greater than 300 days, it may be considered to act as a hydrological basis and the theoretical values of T_R and T_h become:

$$T_R = \frac{L}{\pi K} \ln \frac{4D}{\pi B_w} = 25 \text{ days} \quad (4.45)$$

$$T_h = \frac{L^2}{\Sigma 8KD} = 75 \text{ days} \quad (4.46)$$

Adding 20 days for T_e results in a total drainage resistance, T, of 120 days.

In case of absence of the c₁-layer one has to do with two layers with different hydraulic conductivity. The radial resistance T_R then can be computed from (ERNST, 1962):

$$K_1 T_R = K_1 T'_R + \frac{1}{\pi} \ln \frac{4D_1}{\pi B_w} \quad (4.47)$$

where T'_R is the radial resistance of a semi-circular ditch for which D₁/B_w = π/4. In this case T_R is about 43 days and T_h about 8 days so that T becomes 43 + 8 + 20 = 71 days.

The ratio radial resistance to horizontal resistance is therefore largely depending on the presence of a c₁-layer. Field data show a low value for T_h as compared with T_R, but the total resistance measured in the field is about three times the theoretical value. A reasonable explanation for this is anisotropy in the aquifer. An anisotropy factor of 4 and higher for fluvial sediments like the Drente Formation has been reported by OLSIHOORN (1982). For

Table 4.9. Values for μ , α and T from continuously recorded groundwater levels

Location number	$\bar{\mu}$	$\bar{\alpha}$	\bar{T}
1	0.100	0.09	111
2	0.065	0.04	385
3	0.062	0.09	178
4	0.08	0.05	250

$K_x/K_z = 4$ the following theoretical values are calculated: $T_r = 122$ days and $T_h = 64$ days. With 20 days for the entrance resistance, the total drainage resistance then becomes $T = 122 + 64 + 20 = 206$ days. Both the total resistance and the separate resistances now agree well with measured data.

In the research area the phreatic level was recorded continuously at four places. These recordings, together with data on precipitation, were aimed to find values for the storage coefficient μ of the phreatic aquifer. By selecting so-called depletion curves of the groundwater, i.e. curves for periods in which the water table drops after a period of high rainfall, the reaction factor α can be found by plotting data on semi-logarithmic paper (De ZEEUW, 1966). For this purpose the relation

$$\alpha = \frac{1}{T\mu\eta_f} \quad (4.48)$$

(see eqs. 4.36 and 4.37 for definition of η_f) is used. Table 4.9 gives the average values of $\bar{\mu}$, $\bar{\alpha}$ and \bar{T} obtained. They agree fairly well with the other field data except for location 2 which gives a higher T -value.

5. MODELING OF THE HYDROLOGICAL SYSTEM

5.1. INTRODUCTION

In Chapter 4 a description of the hydrological system and different parameter values have been given. A prediction model for the hydrological system should be able to evaluate the effects of human-imposed changes in the water management by means of a priori chosen variables. According to PRICKETT (1975) a model is defined as 'each method that can duplicate the response of a hydrological system'. Operation with such a model is called simulation.

The most important problem, however, is to construct a consistent system of sub-models and not fall in the pitfall of overmodeling. As FREEZE (1971) says: 'complex models are open to the charge that their sophistication outruns the available data'. DE DONNEA (1978) pointed out that the impact of models in Water Resources Policy and Management is not proportional to the intellectual efforts involved. Also BACHMAT et al. (1980) mention this aspect as one of the reasons for the existence of a gap between model application and management.

The translation of the decomposed hydrological system described in Chapter 4 into a computer program is, from a scientific point of view, not very interesting. In general, however, much effort has to be put in it in order to make the model operational. Calibration of models is sometimes used to improve uncertain input data, but is also necessary to investigate the validity of the model as an image of reality.

The system decomposition and computer program formulation will be dealt with in this chapter. The calibration and verification of the model is subject of Chapter 6, the model results will be discussed in Chapters 7 and 8.

5.2. SYSTEM DECOMPOSITION AND BOUNDARY CONDITIONS

The sub-systems shown in Fig. 4.3 are coupled via external and internal boundary conditions. For the sake of simplicity, minor processes like surface runoff, interflow, precipitation on or evaporation from the surface water system and sprinkling from groundwater or surface water are neglected. All are of minor importance in the research area. This leads

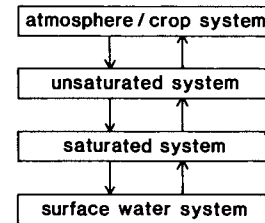

Fig. 5.1. Simplified schematization of system decomposition and relations between sub-systems

to the scheme pictured in Fig. 5.1. The key to simple model formulation is the way of coupling the different sub-systems. Especially the possibilities of replacing two-way relationships between sub-systems by one-way relations are of interest.

5.2.1. Coupling between atmosphere - crop system and unsaturated zone

In fact not the atmospheric conditions at, say, 2 m above the soil surface, but the microclimate in the direct vicinity of crop or soil surface causes changes in transpiration. There are several microclimatic models which take into account this form of feedback. All have the drawback that they need very detailed input data and very small time steps. Therefore they are less suitable for simulation of regional hydrological systems. On the other hand, they can be useful to eliminate systematic errors in less-detailed models.

The method given in Section 4.2 is selected for describing the relationship between the atmosphere - crop system and the land surface. This method does not imply that the potential rate of evapotranspiration, E_p , will always be reached. The actual rate of evapotranspiration may be much lower, but this does not influence the state variables of the atmospheric system. Working in this way the atmosphere acts as an external boundary condition for the unsaturated zone. This means that the two-way relationship between atmosphere - crop system and unsaturated zone can be replaced by a one-way relationship.

5.2.2. Coupling between unsaturated zone and saturated groundwater system

Due to the existence of a zone of complete saturation above the free water surface (capillary fringe), the phreatic level is not the real boundary between saturated and unsaturated soil, but soil water pressure above the phreatic surface is negative and therefore we will take this surface as the boundary between the two systems.

There is no fundamental difference between the two systems as far as it concerns flow of water. Therefore, a number of scientists (e.g. FREEZE, 1971; NEUMAN et al., 1975) consider for modeling the unsaturated and saturated system as one uniform system. De LAAT (1980) presented a review of the consequences of this unified approach that describes flow in terms of pressure head. The problem is that in the unsaturated zone the governing differential equation is non-linear, in the saturated zone linear, while $\frac{\delta h}{\delta \theta} \neq 0$ in the former and zero in the latter. FREEZE (1971) and ABBOT et al. (1979) solved this problem by taking $\frac{\delta h}{\delta \theta} > 0$ in the saturated zone, but there remains the fact that the time constant of the two systems are an order of magnitude different, causing inefficient numerical solutions. Efforts are made to solve this computational difficulty. NARASIMHAN et al. (1977) developed a mixed implicit - explicit procedure for marching in the time domain. HORNING and MESSING (1980) introduced a non-iterative scheme, which combines a predictor - corrector strategy, the Crank - Nicholson's scheme and Alternating Direction Implicit techniques for one-dimensional flow. This scheme, however, is too time-consuming to solve field-size three-dimensional flow problems where the interaction between saturated and unsaturated system is of importance. Therefore the decomposition in two separate systems - the 'traditional approach' - is more attractive. The main reason for this is that the flow to be considered in the unsaturated zone is only vertical.

The separate systems approach leads to a model structure as depicted in Fig. 5.2. The saturated zone is divided into a number of elements by imposing a grid on the region of interest. Each nodal point represents an element formed by the grid. The height of the phreatic surface in a particular point is considered representative for the corresponding element. The exchange of water between the saturated and unsaturated zone in each point is incorporated by means of an upper boundary condition following from a separate one-dimensional flow model for the unsaturated zone.

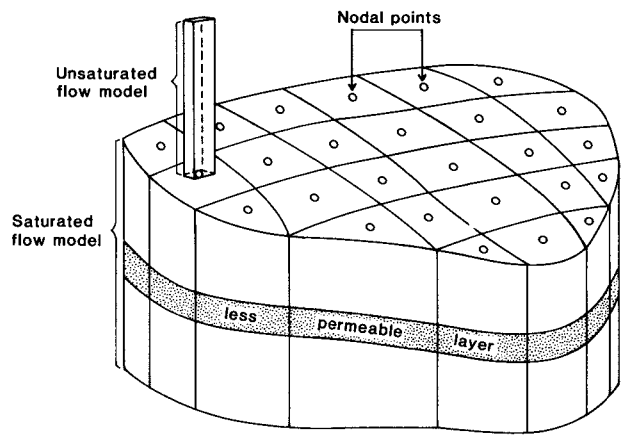

Fig. 5.2. Composition of saturated and non-saturated flow systems

Taking the phreatic surface as an internal boundary, different ways of coupling are possible (see also Table 5.1).

- a) The phreatic surface is considered as a moving boundary. At time t the height of the phreatic surface, $h_f(t)$, is known, either as initial condition or as a result of calculations for a previous period $t - \Delta t$, t . The unsaturated flow model gives a flux, v_f , and a value for the storage coefficient, μ . With these two values a new height of the phreatic surface is calculated for each nodal point of the saturated flow model. The solution in the time domain is achieved by either an implicit or an explicit procedure.

In a fully forward or explicit scheme the value of $h_f(t)$ is the lower boundary condition for the unsaturated flow model. This produces a flux through the phreatic surface $v_f(t)$ between t and $t + \Delta t$. $v_f(t)$ is used as input for the saturated flow model, yielding $h_f(t + \Delta t)$. This value in turn forms the lower boundary condition for the unsaturated flow model during $t + 2\Delta t$, etc.

In a fully backward implicit scheme $h_f(t + \Delta t)$ is used as a lower boundary condition for the unsaturated flow model between t and $t + \Delta t$. Because this value is not a priori known, but depends on the results of the unsaturated flow model itself an iterative procedure is necessary. In the first iteration round $h_f(t + \Delta t)$ is assumed, e.g. equal to $h_f(t)$. The unsaturated flow model yields $v_f(t)$. Introducing it into the saturated flow model yields a new value $h_f(t + \Delta t)$. The storage coefficient is derived from $\mu = f(h_f(t))$, $\mu = f(h_f(t + \Delta t))$ or $\mu = f(h_f(t), h_f(t + \Delta t))$. In the next iteration round

Table 5.1. Different ways of coupling between unsaturated and saturated groundwater system

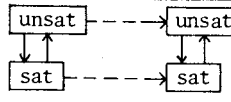
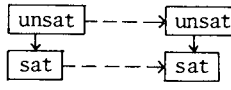
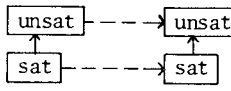
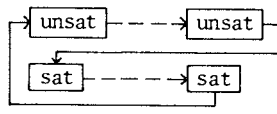
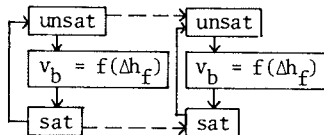
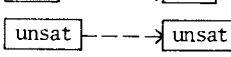
Method	Type of coupling t -----> t + nΔt	Change in boundary conditions due to changes in system itself		Auxiliary equation(s)	References
		unsaturated system	saturated system		
a		$\Delta h_f \neq 0$	$\Delta v_f \neq 0$	$\mu = f(h_f)$ or $\mu = f(h_f, v_f)$	Gilding and Wesseling (1983) Querner and Van Bakel (1985) Pikul et al. (1974)
b	ibid a			$\mu = \text{constant}$	Refsgaard and Hansen (1982)
c		$\Delta h_f = 0$	$\Delta v_f \neq 0$	$\mu = \text{constant}$	
d		$\Delta h_f \neq 0$	$\Delta v_f = 0$		Werkgroep Geohydrologische Aspecten van Grondwaterwinning (1983)
e		$\Delta h_f^{(i)} = 0$ $\Delta h_f^{(i-1)} \neq 0$	$\Delta v_f^{(i)} = 0$ $\Delta v_f^{(i-1)} \neq 0$	$\mu = \text{constant}$	Van Lanen (1983)
f		$\Delta h_f \neq 0$	$\Delta v_b \neq 0$	$\mu = f(v_b)$	De Laat (1980)
g		$\Delta v_b = f(\Delta h_f)$		$v_b = f(h_f)$ from [sat]	this study

[unsat] = unsaturated flow model, [sat] = saturated flow model, h_f = height of phreatic surface, v_f = flux through phreatic surface, v_b = flux through plane below the lowest possible h_f , $\Delta h_f^{(i)}$ = change in h_f during i-th iteration cycle

a new $h_f(t+\Delta t)$ is introduced in the unsaturated model, etc. The iteration is stopped when differences between two successive iterations are smaller than a certain preset value.

In a time-centered scheme a weighted average value of $h_f(t)$ is used as a lower boundary condition for the unsaturated flow model between t and $t+\Delta t$. To find $h_f(t+\Delta t)$ by iteration, the procedure described above is used.

A disadvantage of an explicit procedure is the risk of instability when using too big time steps; an advantage is its simplicity. PIKUL et al. (1974) proved that it is more economical to use an explicit procedure with smaller time steps than an implicit iterative procedure. QUERNER and van BAKEL (1985) found for a regional model for saturated and unsaturated flow that the explicit procedure remained stable, even when a time step of 7 days was applied.

b) A variant of the method described under a) for an integrated surface/subsurface catchment model has been given by REFSGAARD and HANSEN (1982). They use

a time-independent value for μ .

c) A simplification of method a) can be achieved by taking a one-way relationship between the unsaturated and the saturated system i.e. the unsaturated zone is assumed to influence the saturated zone by a flux through the phreatic surface, but changes of the phreatic level induced by this flux are assumed not to influence the flux towards the unsaturated zone. This simplification offers great computational advantages because no iteration is necessary and therefore it is often applied in regional models and situations with rather deep phreatic levels. Although the phreatic surface remains an internal boundary, in fact method c) constitutes a fully decoupled approach. Examples of this approach are groundwater flow models that use net recharge as a function of time as upper boundary condition.

d) A one-way relationship between saturated and unsaturated system is also possible. Changes in the phreatic surface do influence the unsaturated system, but do not affect the feedback mechanism of

the unsaturated zone i.e. v_f or the changes in v_f are ignored. This is true when e.g. the change is fully compensated by a change in evapotranspiration or when the change in v_f is an order of magnitude smaller than the change in flux to the surface water system.

The method is very attractive in analyses of effects of water withdrawal from aquifers. When the fluxes through the phreatic level in the zero situation are known, the drawdown can be calculated by a saturated groundwater flow model only. The calculated phreatic levels then act as lower boundary for the unsaturated zone. This is only permitted if induced changes in the unsaturated zone are small as compared to changes in the saturated groundwater system. The validity of this type of de-coupling has been investigated by the WERKGROEP GEOHYDROLOGISCHE ASPECTEN VAN GRONDWATERWINNING (1983). It concluded that the method is suitable for reproducing the drawdown, but about the possible reduction in evapotranspiration caused by the drawdown nothing is said.

A great disadvantage is the lack of counteracting the wrong assumption of the one-way relationship: $v_f = f(h_f)$. This relationship depends very much on soil physical characteristics of the unsaturated zone, especially on the hydraulic conductivity. This property is difficult to derive from field measurements.

e) A method which takes into account the interaction between the saturated and unsaturated system, but offers the opportunity of simulating both systems separately goes as follows:

- simulate the saturated groundwater system with an initial guess of $v_f^{(1)}$ and known values for the entire simulation period. So

$$\sum_{t=1}^T h_f^{(1)}(t) = g\{\sum_{t=1}^T v_f^{(1)}(t)\} \quad (5.1a)$$

where T is number of simulation steps;

- with the phreatic levels, $h_f^{(1)}$, as lower boundary condition the unsaturated flow is simulated yielding new values for $v_f^{(1)}$, namely $v_f^{(2)}$:

$$\sum_{t=1}^T v_f^{(2)}(t) = g\{\sum_{t=1}^T h_f^{(1)}(t)\} \quad (5.1b)$$

If $v_f^{(2)}$ differs too much from $v_f^{(1)}$, the first and second step are repeated. The procedure can also be started with the second step. In that case an initial guess of $h_f(t)$ is needed.

A disadvantage of the method is that there is no guarantee for convergency, although for practical applications this seems to be no problem (Van LANEN, 1983).

f) The GELGAM model (GELderland Groundwater Analysis Model) is a combination of a quasi-stationary model for the unsaturated (vertical) flow and a quasi three-dimensional model for saturated groundwater flow. Each node of the discretized saturated system is connected with an unsaturated flow model. The method of coupling has been described in detail by De LAAT (1980). The fundamental difference with the method described under a) is that the boundary between the unsaturated and saturated zone is situated below the lowest phreatic level occurring during the simulation period. This eliminates the problem of a moving boundary. The problem of determining the right value for μ is transferred to the unsaturated flow domain. During each time step and for each nodal point the unsaturated flow model yields a stepwise linear relation between the change in the phreatic level and the flux, v_b , over the lower boundary of the unsaturated flow region, written as:

$$v_b(i) = a_1(i) \Delta h_f(i) + b_1(i) \quad (5.2)$$

where a_1 and b_1 are regression coefficients and i is number of nodal point. With these relations the saturated flow model yields the change in phreatic level for the same time step. Now the corresponding value of v_b can be calculated from eq. (5.2) and this lower boundary flux is used in the unsaturated flow model on each node. In the next time step new values for a_1 and b_1 are calculated, with which the new position of the phreatic level is calculated, etc.

In this study a somewhat different coupling has been applied to overcome some of the disadvantages mentioned above.

With the saturated flow model a relationship is established between height of phreatic surface and the flux through this surface for each nodal point or group of points:

$$\sum_{i=1}^N v_f(i) = f\{\sum_{i=1}^N h_f(i)\} \quad (5.3)$$

where N is total number of nodal points. This relationship is used as the Cauchy type of lower boundary condition in the unsaturated flow model. For computational reasons the lower boundary of the unsaturated system is set below the lowest height of the phreatic surface occurring during the simulation period. The hydraulic head at this boundary is taken equal to the phreatic level. Neglecting the hydraulic gradient in the saturated zone between the phreatic level, h_f , and the lower boundary of the unsaturated system, $z =$

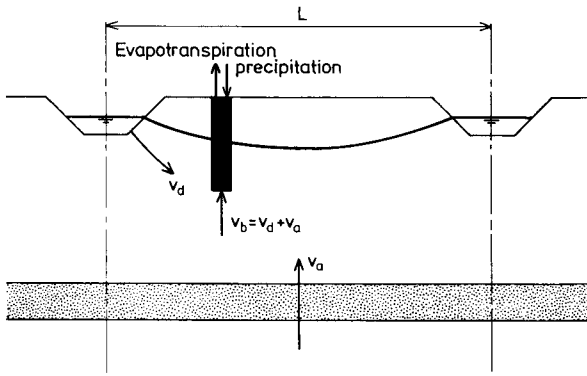

Fig. 5.3. Schematic representation of fluxes involved in the groundwater flow system

z_b , the drainage resistances discussed in Chapter 4 can be used to find the groundwater flux to the open water system. Also a flow towards or from deeper aquifers can be introduced by incorporating it in the boundary flux. Denoting this flux as $v_b(h_f)$, one has (Fig. 5.3):

$$v_b(h_f) = v_d(h_f) + v_a(h_f) \quad (5.4)$$

where v_d is flux to the ditches and v_a is flow to the deep aquifer. For v_d one can use:

$$v_d = - \frac{1}{\eta_f} \frac{\bar{h}_f - h_o}{T} \quad (5.5)$$

and for v_a :

$$v_a = - \frac{\bar{h}_f - h_m}{c_1} \quad (5.6)$$

where h_m is hydraulic head in the middle aquifer and c_1 the vertical resistance of the semi-confining layer in between. It must be remarked that in principle both v_d and v_a vary with the distance to the ditch. To get a representative situation the unsaturated model is thought to pertain to the place where $h_f = \bar{h}_f$ (Fig. 5.3).

In this way the unsaturated system is related to the surface water system (h_o) and the aquifer (h_m). That gives impulses on it. All storage changes in the soil are now restricted to the unsaturated system. A number of scientists working on modeling of the unsaturated zone apply a similar procedure, for example De LAAT (1979) and BELMANS et al. (1983).

In the chosen approach there is no relation between height of the phreatic surface and hydraulic head of the deep aquifer, so in fact the coupling between unsaturated and saturated zone is reduced to a one-way relationship. Especially in situations where changes in height of the phreatic surface induced by e.g. surface water management change the regional pattern of groundwater flow this simplification is not allowed. Because in the area under consideration regional effects may occur, it will be described later how to account for these effects without complicating the modeling (Section 5.5).

5.2.3. Coupling between saturated groundwater and surface water system

Usually the relation between the surface water system and the saturated groundwater system is conceptually modeled as a one-way relationship between surface water and groundwater, i.e. the surface water system is a boundary with prescribed head in the saturated groundwater model. A one-way coupling between saturated groundwater system and surface water system is applied in numerous Hydrograph Synthesis models. The Stanford watershed model e.g. has a module for routing the water coming from the 'soil' module in the surface water system. For a detailed review, the reader is referred to KRAYENHOFF VAN DE LEUR et al. (1966). In a two-way relationship the surface water level, h_o , depends on the magnitude of the drainage flux, v_d , which in turn depends on h_o .

The consequences of the use of one- and two-way coupling are given by ERNST (1978). He solved the drainage problem of undulating sandy soils analytically with and without an interaction between groundwater and surface water. The two relationships between v_d and h_f deduced for these cases did not show much difference. On the other hand Van LANEN and HEY (1978) concluded from results of the GELGAM-model in a region influenced by groundwater extraction, that the assumption of no interaction sometimes may lead to underestimating of the drawdown of the groundwater table.

Having separate mathematical models for the saturated groundwater and the surface water system and having the boundary between them fixed (the bottom of the surface water system) the coupling between the two systems can be done by means of an iterative procedure as described in Section 5.3 under method a). Starting with the surface water level as a boundary for the model of the saturated groundwater system,

the latter yields a flow to the surface water system. Next the computed flow is used as a boundary condition in the surface water model, yielding a new surface water level. This procedure is repeated until agreement has been reached.

The main drawback of this procedure is computational inefficiency caused by the fact that the time constants involved differs by several orders of magnitude. As will be shown later this problem can be overcome by adjusting the time step in the separate systems to their corresponding characteristic times (see also GILDING and WESSELING, 1983).

5.5. THE ACTUAL MODELING

5.3.1. Problem description

After having discussed principles and methods of modeling and procedures to describe the coupling between various sub-systems, the actual modeling will be dealt with.

The problem under discussion is schematically given in Fig. 5.4. The water management of the water-board comes in fact to the regulation of the open water level in the main canals by means of manipulating the discharge outlet and, if supply water is available, the inlet structure. In this way the open water level in the tertiary ('wijken') system in fact is manipulated too. In dry periods this system loses water towards the groundwater (flux v_d) which creates in turn better soil water conditions for crop growth in the form of increasing transpiration.

Due to changes in the open water level the regional groundwater flow may be influenced, causing changes in the flux v_a .

The problem to be solved now is to link the surface water system to the groundwater system and relate them with the processes in the unsaturated zone, so that the effects of the water management measures become clear. Numerical models that can be used to simulate the effects of surface water manipulation as well as by waterboards for their management have to obey the following conditions:

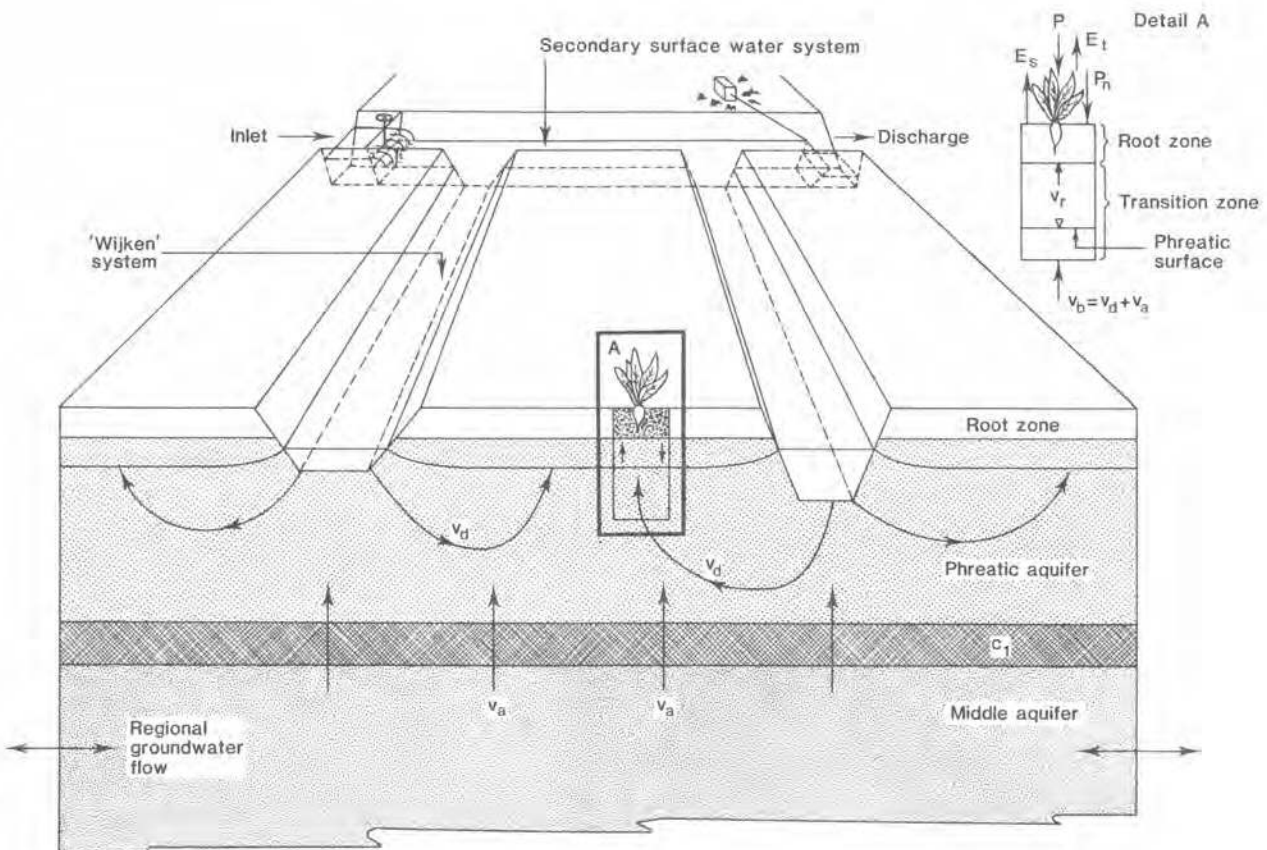

Fig. 5.4. Structure of the problem to be solved

- a) the system must be capable to simulate the day-to-day water management;
- b) the smallest unit to be considered is a section, i.e. an area served by one open water level;
- c) the information available to the waterboard is limited to discharge, open water level and sometimes one or a few groundwater table depths for each section.

The GELGAM-model (De LAAT and AWATER, 1978) that links groundwater flow and unsaturated flow uses Dirichlet-type boundary conditions. In addition it has no possibility for taking into account waterlogging problems. Moreover the model uses time periods of 10 days, which are too long for the problem under discussion here. Therefore a new one-dimensional model has been developed that uses Cauchy-type boundary conditions to link saturated and unsaturated flow and gives a possibility of handling day-to-day changes in open water levels. This model called SWAMP (Surface Water Management Program) will be discussed hereafter. Before doing so some basic conventions that have been used throughout the text are given.

Because the model is basically one-dimensional, fluxes and amounts of water are expressed per unit surface area.

The elevations of phreatic surface and open water level are expressed in cm below soil surface i.e. depth. To distinguish them from heights they are marked with an asterisk.

For simulation of transient water flow in principle a time step, Δt , of one day is used. If necessary this time step is reduced, especially in the case of open water. State variables with argument t represent the variable at time t , fluxes with argument t represent the flux between t and $t+\Delta t$.

Volumes of water (e.g. water content of the root zone) are expressed in mm, fluxes are given in $\text{mm}\cdot\text{d}^{-1}$.

5.3.2. The open water system

The open water of interest for the modeling can be divided into three parts. The first one (the primary system) delivers water to the area under consideration. The second part (secondary system) is the system of watercourses taken care of by the waterboard. In the present study this is the main canal system. The last part (the tertiary system) distributes the water over the area. In our case this part is formed by the small canals ('wijken').

The only figure about the primary surface water system of interest for modeling the water management is its supply capacity per unit area, s_p . However, s_p

never can exceed the capacity of the inlet structure of the area, s_i . So the supply capacity used in the model, s_m , is either bound by s_p or by s_i . The actual supply rate, $v_{o,p}$, from the primary to the secondary system is determined during the simulation, but can never exceed s_m , so:

$$v_{o,p}(t) = v_{o,p} \quad \text{if } v_{o,p} \leq s_m \quad (5.7)$$

$$v_{o,p}(t) = s_m \quad \text{if } v_{o,p} > s_m \quad (5.8)$$

The secondary system maintained by the waterboard is modeled as a reservoir. The state of the reservoir is expressed as the level of the surface water, $h_{o,s}^*$, that can be calculated from:

$$h_{o,s}^*(t+\Delta t) = h_{o,s}^*(t) + 0.1\Delta t\{v_{o,s}(t) + v_{o,w}(t) - v_{o,p}(t)\}/a_s \quad (5.9)$$

where $v_{o,s}$ is the flow rate from the secondary to the tertiary system, $v_{o,w}$ is the flow rate over downstream weir and a_s is the fraction of the area covered by the secondary system. This area is, in general, so small that evaporation from it and precipitation on it can be neglected.

In model terms the adjustable weirs are imaged as a level (depth of weir crest, h_w^*) that can be moved up or down with a given speed. The required change in weir crest depth is found by comparing the differences between the actual surface water level upstreams from the weir and a certain target level. For practical reasons a certain preset difference is allowed before the weir is adjusted. The establishing of the target level is governed by a number of operation rules that will be treated in Chapter 7.

The discharge rate, $v_{o,w}$, is calculated with eq. (4.33). To convert $h_{o,s}^*$ (surface water level representative for the entire secondary system) to the upstream water level, $h_{o,w}^*$, required to compute the discharge over the weir, the backwater effect is taken into account using Manning's formula (eq. 4.30) in the form:

$$h_{o,w}^*(t) = h_{o,s}^*(t) + C_M\{v_{o,w}(t)\}^2 \quad \text{if } v_{o,w} > 0 \quad (5.10)$$

$$h_{o,w}^*(t) = h_{o,s}^*(t) \quad \text{if } v_{o,w} = 0 \quad (5.11)$$

where the input variable C_M is a constant representing the average hydraulic properties of the secondary system. It may depend on $h_{o,s}^*$ and growing stage of water weeds.

Now the flow over the weir $v_{o,w}$ can be calculated from:

$$v_{o,w} = c_d (h_w^* - h_{o,w}^*)^n \quad \text{if } h_w^* > h_{o,w}^* \quad (5.12)$$

$$v_{o,w} = 0 \quad \text{if } h_w^* < h_{o,w}^* \quad (5.13)$$

where c_d is model discharge coefficient to be calculated from:

$$c_d = C_d^1 \times a_w \times 8640 \quad (5.14)$$

and a_w is specific width of weir.

The tertiary system of the small canals ('wijken') is also modeled as a reservoir. The state of this reservoir is the surface water level, $h_{o,t}^*$. The water balance of this reservoir reads:

$$h_{o,t+\Delta t}^* = h_{o,t}^* + 0.1\Delta t \{ (v_d(t) - f_r(t))a_g - v_{o,s} \} / a_t + E_o(t) - P(t) \quad (5.15)$$

where v_d is flux to ditches, f_r surface runoff, E_o evaporation from open water, P precipitation and a_t and a_g fractional areas covered by the tertiary system and the ground surface, respectively. The value of $v_{o,s}$ can be derived from (see eq. 4.34):

$$v_{o,s}(t) = C_t \{ h_{o,s}^*(t) - h_{o,t}^*(t) \}^2 \quad \text{if } h_{o,s}^* > h_{o,t}^* \quad (5.16)$$

$$v_{o,s}(t) = -C_t \{ h_{o,s}^*(t) - h_{o,t}^*(t) \}^2 \quad \text{if } h_{o,t}^* \leq h_{o,s}^* \quad (5.17)$$

The factor C_t takes into account the hydraulic properties of the system and is an input variable. Eqs. (5.16) and (5.17) are only applicable if the surface water levels are above the bottom depth of the system, $h_{o,c}^*$. Therefore eqs. (5.16) and (5.17) have been extended with:

$$v_{o,s}(t) = C_t (h_{o,t}^* - h_{o,c}^*)^2 \quad \text{if } h_{o,t}^* < h_{o,c}^* \quad \text{and } h_{o,s}^* > h_{o,c}^* \quad (5.18)$$

$$v_{o,s}(t) = -C_t (h_{o,s}^* - h_{o,c}^*)^2 \quad \text{if } h_{o,t}^* \geq h_{o,c}^* \quad \text{and } h_{o,s}^* < h_{o,c}^* \quad (5.19)$$

$$v_{o,s}(t) = 0 \quad \text{if } h_{o,t}^* > h_{o,c}^* \quad (5.20)$$

Data on the geometry like mutual distance, bottom width, bottom depth and side slopes of the tertiary watercourses are input variables, because they determine the value of the fractional area a_t .

To maintain numerical stability in case the surface water level comes below the bottom depth, the water surface is reduced to half the bottom width.

5.3.3. The unsaturated system

In the unsaturated system the processes between soil surface and the lowest possible height of the phreatic surface are described. This system is divided into the root zone and the transition zone (Fig. 5.4). The root zone is modeled as a reservoir with storage W_r . The water balance of this reservoir reads:

$$W_r(t+\Delta t) = W_r(t) + \Delta t \{ (-E_s(t) - E_t(t) + P_n(t) - f_i(t) + v_r(t) \} a_g \quad (5.21)$$

where v_r is flux through the lower boundary of the root zone. Soil evaporation, E_s , and net precipitation, P_n , are input variables. They are calculated with the unsaturated flow model SWATRE (for a description of the model see BELMANS et al., 1983). The net precipitation in this model is calculated as:

$$P_n(t) = P(t) - E_i(t) \quad (5.22)$$

where E_i is evaporation rate of intercepted precipitation, to be estimated with:

$$E_i(t) = uP(t)^{(v-wP(t))} S_c \quad (5.23)$$

where u , v and w are regression coefficients and S_c is soil cover fraction. The soil evaporation rate, E_s , in SWATRE is calculated as the minimum of the Darcian flux from the top nodal point of the model to the soil surface and a flux derived from an empirical relationship, according to BLACK et al. (1969):

$$E_s(t) = \lambda_s \sqrt{t'+1} - \lambda_s \sqrt{t'} \quad (5.24)$$

where λ_s is soil-dependent parameter and t' is time after the dry period started, d . The transpiration rate, E_t , is calculated as:

$$E_t(t) = \alpha_T E_{t,p}(t) \quad (5.25)$$

where $E_{t,p}$ is potential transpiration.

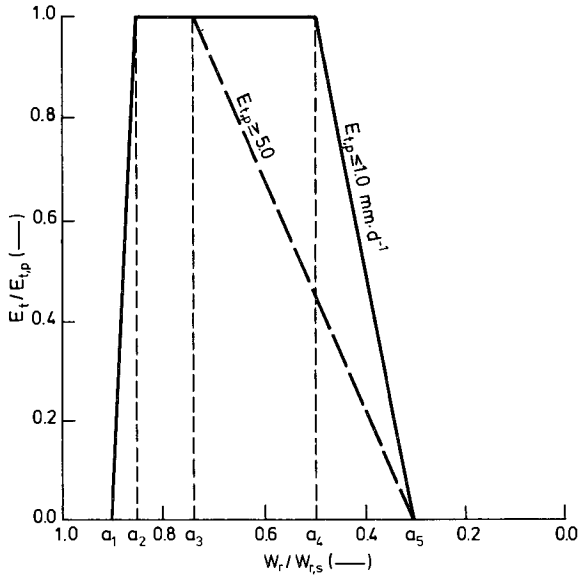

Fig. 5.5. Functions relating relative transpiration, $E_t/E_{t,p}$, and relative water storage in the root zone, $W_r/W_{r,s}$, used for the computation of reduction in transpiration caused by soil water conditions

Contrary to the approach used in SWATRE where the reduction of the potential transpiration depends on the pressure head in the root zone, here α_T is taken to be dependent on the relative water storage of the root zone, $W_r/W_{r,s}$ (Fig. 5.5) where $W_{r,s}$ is the water storage of the root zone at complete saturation. In the figure a_1 represents the anaerobiosis point and a_5 the wilting point. Between these two values the reduction depends on $W_r/W_{r,s}$ and the evaporation demand of the atmosphere. The values a_1 through a_5 are input variables.

The flux through the lower boundary of the root zone, v_r , is calculated as:

$$v_r(t) = f\{W_r(t), W_r(t+\Delta t)\} \quad (5.26)$$

if $W_r \geq W_{r,e}$

$$v_r(t) = f\{h_f^*(t), h_f^*(t+\Delta t), W_r(t), W_r(t+\Delta t)\} \quad (5.27)$$

if $W_r < W_{r,e}$

where $W_{r,e}$ is soil water storage of the root zone when $v_r = 0$ (equilibrium situation), so:

$$W_{r,e} = f(h_f^*) \quad (5.28)$$

Eq. (5.26) expresses that $v_r(t)$ depends on the water storage of the root zone while eq. (5.27) gives the capillary rise. Relevant data are obtained from a finite difference model for steady-state unsaturated flow. This model yields pressure head profiles for

different values for h_f^* and v_r . With the help of the soil water retention curve the pressure head is converted into water content.

The transition zone (Fig. 5.4) is also modeled as one single reservoir with a water storage W_s . The water balance of this reservoir reads:

$$W_s(t+\Delta t) = W_s(t) - \Delta t\{v_r(t) + v_b(t)\}a_g \quad (5.29)$$

where v_b is the flow rate at the bottom of the reservoir (below lowest possible h_f^*) written as:

$$v_b(t) = v_a(t) + v_d(t) \quad (5.30)$$

in which v_a is the regional groundwater flow component and v_d is the exchange with the surface water system (see Fig. 5.4). The value of v_d is derived from (see eq. 4.48):

$$v_d(t) = f\{h_f^*(t), h_f^*(t+\Delta t), h_{o,t}^*(t), h_{o,t}^*(t+\Delta t)\} \quad (5.31)$$

and v_a is derived from:

$$v_a(t) = f\{h_f^*(t), h_f^*(t+\Delta t), h_{o,t}^*(t), h_{o,t}^*(t+\Delta t)\} \quad (5.32)$$

The latter relation is input for the SWAMP model and is derived from the FEMSATS model (Paragraph 5.5.4).

The depth of the phreatic surface is calculated as:

$$h_f^*(t+\Delta t) = h_f^*(t) - \frac{W_s(t+\Delta t) - W_s(t)}{\mu_s(t)} \quad (5.33)$$

where μ_s is storage coefficient of the transition zone depending on h_f^* and v_r according to:

$$\mu_s(t) = \mu_{s,e}(t) \quad \text{if } h_f^* < h_{f,b}^* \quad (5.34)$$

$$\mu_s(t) = \mu_{s,e}(t) \quad \text{if } v_r \leq 0 \quad (5.35)$$

$$\mu_s(t) = f\{h_f^*(t), v_r(t)\} \quad \text{if } v_r > 0 \text{ and } h_f^* > h_{f,b}^* \quad (5.36)$$

where $h_{f,b}^*$ is a groundwater depth at which the profile is so wet that the gradient in hydraulic head can always be neglected and $\mu_{s,e}$ is storage coefficient of the transition zone when $v_r = 0$ (equilibrium situation), so:

$$\mu_{s,e} = f(h_f^*) \quad (5.37)$$

Eq. (5.36) is derived from the pressure head curves obtained with the above described steady-state model for unsaturated flow by converting them into saturation deficit curves for the transition zone with the help of the soil water retention curves. This relationship depends

on the soil physical unit considered and is input for the model just as eq. (5.37).

5.3.4. The saturated groundwater system

The saturated groundwater system of the entire area was modeled with the stationary version of the computer program FEMSAT (acronym for Finite Element Model for SATurated groundwater flow) for quasi-three-dimensional flow (van BAKEL, 1978; QUERNER, 1984) making use of the geohydrological information given in Chapter 4. The surface water system was built in as constant head boundary and coupling with the saturated system was done through a drainage resistance specified for each node.

Taking the upper boundary of the saturated system at the lowest possible phreatic level means that storage in the saturated system is eliminated so that the state variables of the saturated groundwater system for various boundary conditions can be calculated with FEMSATS.

FEMSATS was run for a series of fluxes, v_f , through the upper boundary. In this way for each node relationships were established between v_f and the height of the phreatic surface, h_f .

In principle this relationship depends upon both v_f and the surface water level in the node considered and in all other nodes. The phreatic level in any arbitrary nodal point i can be written as:

$$h_f(i) = (a_1, \dots, a_N) \begin{Bmatrix} v_{f,1} \\ \vdots \\ v_{f,N} \end{Bmatrix} + (b_1, \dots, b_N) \begin{Bmatrix} h_{o,1} \\ \vdots \\ h_{o,N} \end{Bmatrix} \quad (5.38)$$

where a_1, \dots, a_N and b_1, \dots, b_N form the i -th row of the influence matrices A and B, respectively, and

N is total number of nodal points. The coefficients of A and B can vary with v_f and h_o , except in the case of a fully linear model where they are constant.

A considerable reduction in computational time can be achieved by assuming that v_f and h_o in all nodes are uniquely correlated with each other. This reduces the two influence vectors for upper boundary fluxes and open water levels to a single equation of the form:

$$h_f(i) = f\{v_f(i), h_o(i)\} \quad (5.39)$$

The regional pattern of the flux v_f must be strongly correlated because piezometers show a narrow correlation (Table 5.2). Differences in $v_f(t)$ from node to node originate from differences in actual evapotranspiration minus net precipitation. Systematic differences in net precipitation can be ignored. Differences in actual evapotranspiration between the nodes are caused by differences in groundwater table and physical properties of the unsaturated zone. By taking per nodal point a unique relation between capillary rise and groundwater depth and taking as upper boundary conditions not a flux boundary but a boundary where $v_f = f(h_f^*)$ (Cauchy condition), the regional correlation which is in reality present, is taken into account. The assumption is, however, not always correct. For instance the maximum difference in soil water retention capacity of the root zone between an improved peaty soil (rooting depth 40 cm) and a podzolic soil (rooting depth 20 cm) is about 50 mm. This difference causes a difference in total evapotranspiration during an average and a dry year of 30 mm and 60 mm respectively (van WALSUM and van BAKEL, 1983). As a result, the rise of the phreatic surface in autumn in the first soil will start later than in the latter. During the time that this occurs,

Table 5.2. Matrix of correlation coefficients of a number of piezometers in 'De Monden'

	15	16	17	18	19	20	21	22	23	24	25	26	27	28	29	30	31
15	1.00																
16	0.96	1.00															
17	0.91	0.96	1.00														
18	0.89	0.96	0.98	1.00													
19	0.93	0.95	0.94	0.95	1.00												
20	0.81	0.89	0.93	0.94	0.92	1.00											
21	0.85	0.91	0.92	0.92	0.88	0.88	1.00										
22	0.87	0.91	0.91	0.89	0.90	0.84	0.92	1.00									
23	0.92	0.91	0.87	0.86	0.90	0.82	0.85	0.90	1.00								
24	0.84	0.91	0.94	0.95	0.91	0.93	0.91	0.90	0.86	1.00							
25	0.87	0.92	0.95	0.95	0.92	0.92	0.92	0.91	0.86	0.99	1.00						
26	0.88	0.93	0.94	0.94	0.92	0.89	0.94	0.93	0.87	0.97	0.99	1.00					
27	0.87	0.92	0.95	0.95	0.94	0.92	0.93	0.92	0.85	0.97	0.98	0.98	1.00				
28	0.84	0.90	0.94	0.94	0.91	0.92	0.91	0.89	0.82	0.96	0.96	0.96	0.97	1.00			
29	0.85	0.88	0.89	0.89	0.91	0.88	0.84	0.82	0.83	0.91	0.92	0.90	0.91	0.90	1.00		
30	0.83	0.86	0.87	0.89	0.86	0.84	0.85	0.81	0.79	0.90	0.90	0.90	0.94	0.91	0.85	1.00	
31	0.66	0.75	0.80	0.82	0.76	0.84	0.81	0.76	0.66	0.86	0.84	0.83	0.87	0.85	0.77	0.88	1.00

the assumption that v_f and h_o are uniquely correlated is violated. This discrepancy will happen at the beginning of the wet season and will last on the average for about one month. In general, this time is not of interest for surface water manipulation, because at that time the surface water will be already at winter level. Of course, v_f may vary within a node due to differences in crop, differences in soil properties, etc., but these differences will be leveled out by local saturated groundwater flow and will not affect the regional groundwater flow pattern.

The assumption for a unique correlation of the open water levels in all nodal points is quite reasonable. Raising and lowering of the surface water level is exclusively handled by the waterboard and, in general, the time at which changes are performed is the same for all sections. Differences in changes, however, are possible and the consequences of that on the validity of eq. (5.39) have to be considered.

A relation like eq. (5.39) for each nodal point was obtained by running FEMSATS with values for h_o differing per section and different v_f -values. Because v_f is equal to v_b (eq. 5.30) and the magnitude of v_d is known from h_f , h_o and τ , v_a is known too and a relation between v_a and h_f can be derived.

A section (which has one surface water level) covers a number of nodal points. From the values for h_f and v_a for all nodal points in a section average values \bar{h}_f and \bar{v}_a for that section were computed. Taking into account the average soil surface elevation of a section the relationship between \bar{v}_a , \bar{h}_f and h_o^* was established being:

$$\bar{v}_a(j) = f(\bar{h}_f(j), h_o^*(j)) \quad (5.40)$$

where j is section number. Eq. (5.40) is used to take into account the effects of water management in the area on the regional groundwater flow and vice versa.

5.3.5. Computational procedure in SWAMP

A number of relationships in the previous sections are interactive in the sense that rates depend on state variables and state variables are influenced by rates. To solve this problem an interactive numerical procedure is required. With the same procedure, non-linear relationships can be handled.

The numerical procedure for solving the system of equations incorporated in SWAMP comprises the following steps:

- 1) the state variables at time t are known, either as initial conditions or as a result of computations for a previous time step;

- 2) a number of fluxes and parameters for the period $t, t+\Delta t$, some state variables and fluxes at $t+\Delta t$ are copied from the previous time step to be used in the first iteration round of the next time step;
- 3) fluxes between t and $t+\Delta t$ and state variables at $t+\Delta t$ are calculated using the equations given in the previous sections;
- 4) the variables calculated in step 3 are compared with the first estimates;
- 5) depending on the result of the comparison in step 4), parameters are adjusted and steps 3) and 4) are repeated until the difference in h_f from two consecutive iterations is smaller than a preset value.

The procedure given is in fact a relaxation method. Because some functional relationships used in the model are non-linear, this procedure is only stable when Δt is smaller than a certain critical value, Δt_c . Each sub-system has its own value $\Delta t_{c,i}$, the magnitude of it being dependent on:

- the degree of non-linearity in the functional relationships involved;
- the time constant, τ , of the sub-system to be defined as:

$$\tau_i = S_i w_i \quad (5.41)$$

where S_i is storage coefficient and w_i is specific resistance. As an example suppose that the entire system could be restricted to the transition zone of the unsaturated system and the tertiary surface water system only. Furthermore let T, μ, a_g and a_t be 200, 0.1, 0.98 and 0.02, respectively. Then the transition zone would have a τ -value of $200 \times 0.1 \times 0.98 = 19.6$ days and the tertiary surface water system $200 \times 1.0 \times 0.02 = 4$ days. This example shows that great differences in time constant between the different sub-systems occur. In fact the situation is even worse, because the flow resistance over weirs is much lower than the resistances for groundwater flow.

The large difference in τ between the groundwater system and the surface water system may result in an inefficient numerical procedure. Therefore in the iterative procedure an explicit calculation of the state variables and fluxes in the surface water system with a small time step, $\Delta t'$, is nested by using the depth of the phreatic surface, calculated with the iterative procedure within one explicit cycle as a boundary condition. It turned out that for Δt and

Δt 1 and 0.01 day, respectively, the model did not show any instability.

For the change in target level of surface water depth $h_{o,m}^*$, a special subroutine was developed, which will be dealt with in Chapter 7.

6. MODEL CALIBRATION AND VERIFICATION

6.1. INTRODUCTION

According to BEVEN and O'CONNELL (1982) model calibration means the selective improvement of initial parameter estimates through comparison of observed and simulated variables. Others (CONTACTGROEP GRONDWATERMODELLEN, CHO-TNO, 1982) define calibration as the establishment of values for the parameters.

The first definition is more or less a 'trial and error' calibration. The values of parameters are changed in a heuristic way till the best possible agreement between the output of the model and observed data is reached. A disadvantage is that there is no evidence that the final parameters introduced are the best ones.

To overcome this disadvantage, a sensitivity analysis can be carried out, i.e. the systematic evaluation of changes in parameters or boundary conditions.

The second definition is broader and includes the inverse use of models. This means that instead of simulating hydrological variables from input parameter values, field data are used as input in the model to find values for the parameters. These field data have to be accurate, because otherwise the parameter values can become physically unrealistic. To overcome this difficulty preset conditions with respect to the ranges of the parameters can be incorporated in the model.

Verification or validation of a model means testing whether or not it is acceptable. This has to be done by comparing observed and simulated variables. Of course, field data used for verification must be independent from those used for calibration.

The question of acceptability of a model can be answered by using objective criteria. A criterium, widely used, is the efficiency factor, R_e (NASH and SUTCLIFFE, 1970), defined as:

$$R_e = 1 - \frac{\sum(F - F')^2}{\sum(F - \bar{F})^2} \quad (6.1)$$

where F is the measured variable, F' is the simulated one and \bar{F} is the average of the measured variables. If observed and simulated data fully agree $R_e = 1$.

In the hydrological model for the region 'De Monden', as discussed in Chapter 5, there is a large number of parameters so that calibration is complicated. Therefore the models FEMSATS and SWAMP are calibrated separately. Calibration of FEMSATS will be treated in Section 6.2. A real calibration of SWAMP was not possible because during the period of observations (1978-1981) hardly any reduction in potential transpiration occurred. Therefore it is impossible to calibrate e.g. soil water characteristics or hydraulic conductivities. Almost any combination of parameters will yield the same result, namely potential transpiration. Besides, determination of the $\theta(h_p)$ and $K(h_p)$ -relationships per soil physical unit, as discussed in Chapter 4, is already the product of a calibration process. Hence, calibration of these relationships with a flow model would mean a rejection of the validity of the methods of determination. Other parameters in SWAMP, like the thickness of the root zone and the geometrical and hydraulic properties of the surface water system were derived from the physical description of the region, given in Chapter 4. The values for the drainage resistance are calibrated with FEMSATS.

Verification of FEMSATS will be discussed in Section 6.3 and of SWAMP in Section 6.4. Because verification of SWAMP was not quite satisfactory, a kind of pseudo-verification has been carried out by comparing the results of SWAMP with those of a modified version of SWATRE (Section 6.5).

The method to use the results of FEMSATS as part of the lower boundary condition in SWAMP, discussed in Chapter 5, is verified in Section 6.6.

6.2. CALIBRATION OF FEMSATS

6.2.1. Procedure

In FEMSATS the initial values for the geo-hydrological parameters (i.e. K_1D_1 , c_1 , K_2D_2 , c_2 , K_3D_3 , T) were those described in Chapter 4. In a number of cases these values were obtained from water balances e.g. T , c_1 and c_2 . The initial values have been im-

proved by the 'trial and error' calibration method in FEMSATS. The objective functions were agreement between measured and simulated hydraulic heads in the different aquifers. The 'trial and error' calibration was chosen because 1) the accuracy of the field data was insufficient and 2) FEMSATS is only used to establish the functional relationship $v_a = f(h_f^*, h_o^*)$ per section (eq. 5.40).

A problem with calibration of parameter values in a steady-state flow model is that field data varies

with time and depends on the history while a steady-state model has, by definition, no memory. Therefore calibration of parameters in a steady-state model is only possible for field data from periods with small changes in storage. The period 10 Oct. 1980 - 27 Feb. 1981 was such a period. The change in storage in the phreatic aquifer, derived from changes in height of the phreatic surface during this period was 15 mm (van KEULEN, 1982). The change in storage in the deeper layers can be ignored, as was already

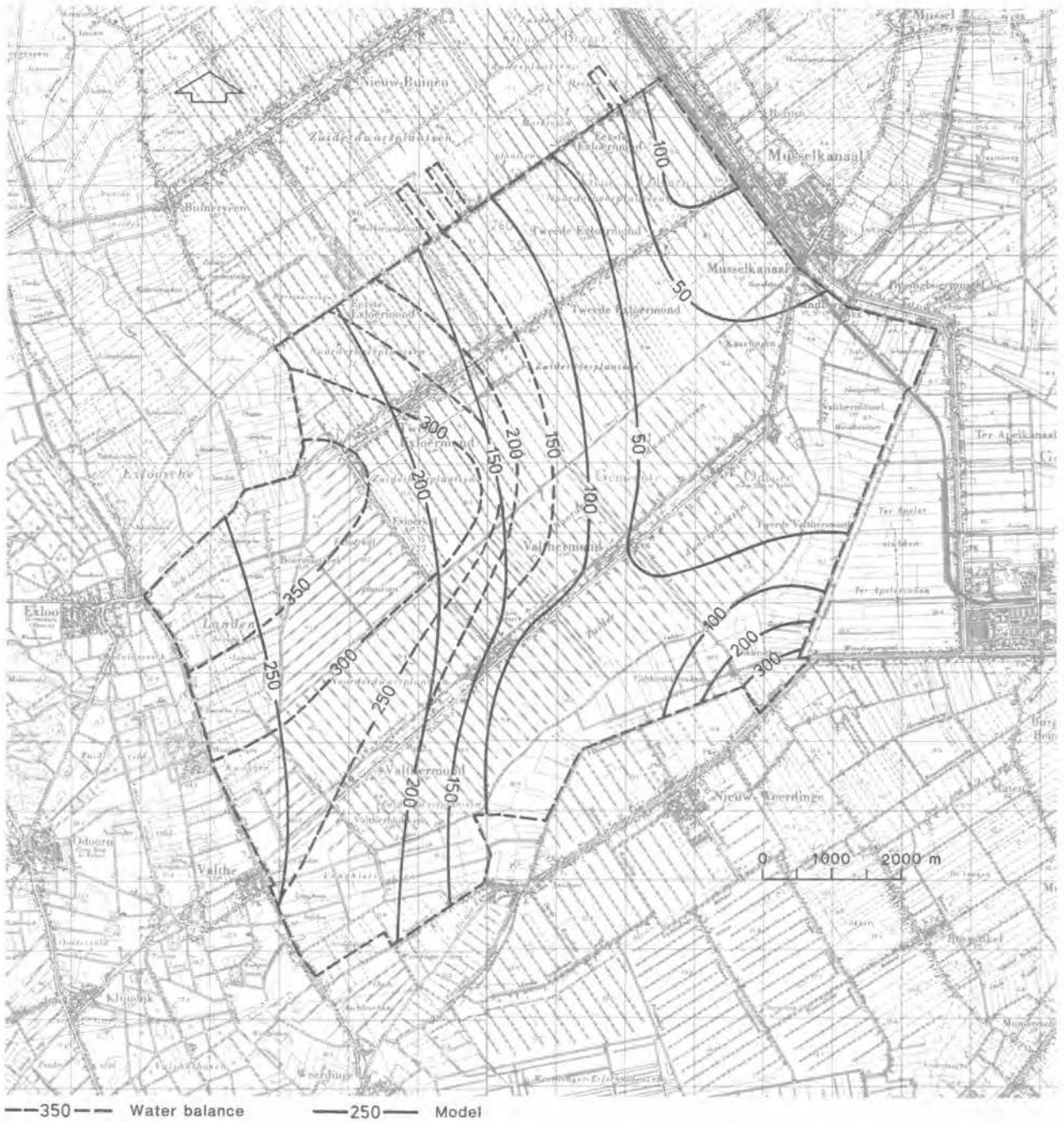

Fig. 6.1. Comparison between c_1 -values calibrated with FEMSATS (full lines) and those derived from water balances (dotted lines)

proved in Chapter 4.

As boundary conditions for FEMSATS during the period the following data were used:

- the upper boundary flux, $v_F = -1.96 \text{ mm} \cdot \text{d}^{-1}$ throughout the area, viz. the average precipitation surplus during this period;
- per section an average open water level, derived from field data;
- per nodal point on the boundary of the region a hy-

draulic head, also derived from field data.

With these data FEMSATS was run, yielding values for the hydraulic heads in the different layers and the discharges per section. In order to restrict the almost infinite possibilities to adjust the geo-hydrological parameters per nodal point, only those parameters were calibrated 1) which could not accurately be determined from geo-hydrological data, 2) which have a great influence on the model results

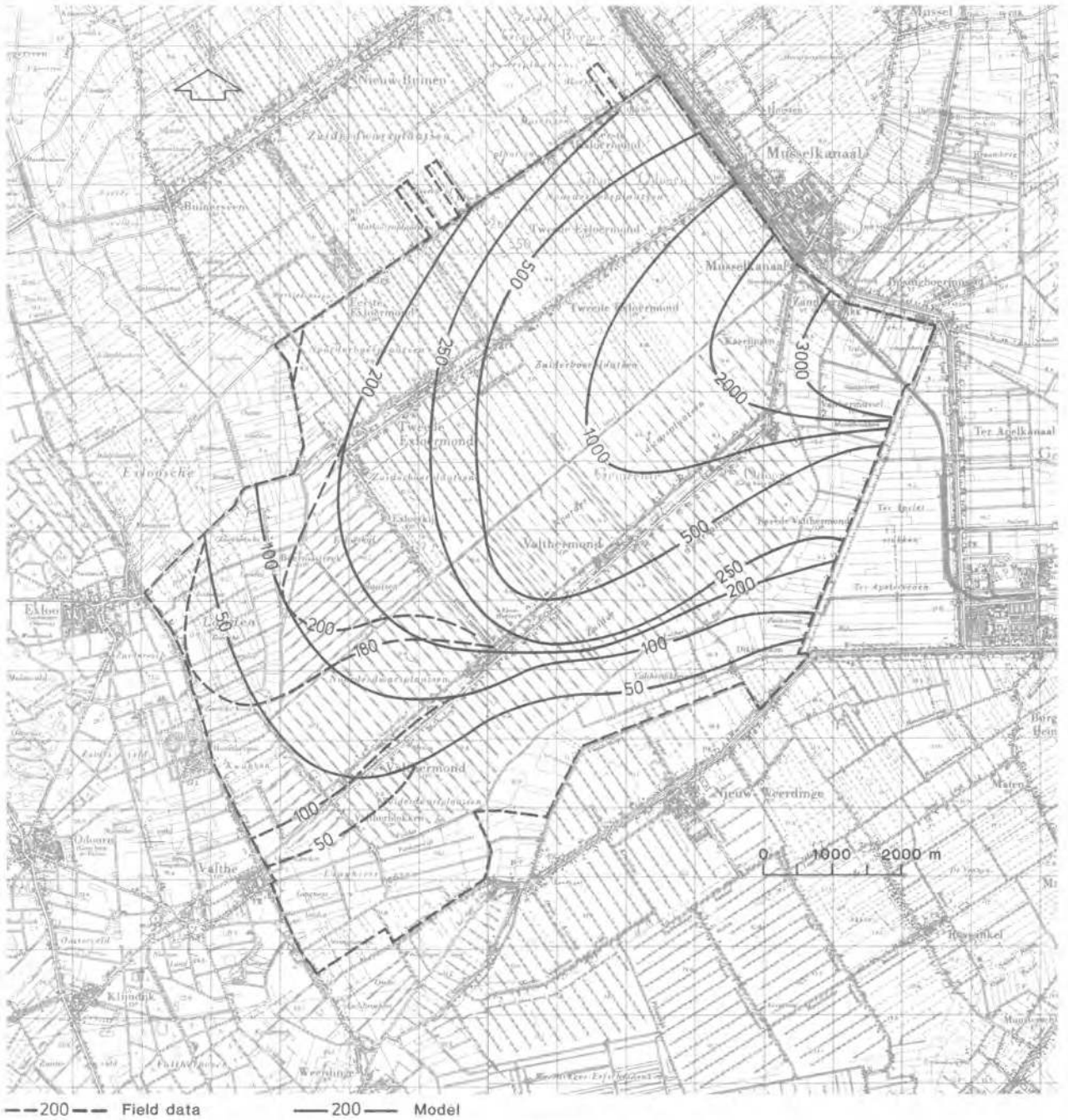

Fig. 6.2. Comparison between c_2 -values calibrated with FEMSATS and those derived from water balances

and 3) for which field data were available for calibration. These restrictions meant that only the parameters c_1 , c_2 and T have been calibrated.

6.2.2. Results of calibration

In Fig. 6.1 the calibrated isoline pattern of the resistance between phreatic and middle aquifer (c_1) is compared with the initial pattern. Only in the north-

western part of the region the c_1 -value had to be changed. This adjustment is in good agreement with the (scarce) data about the extension of Eemian deposits.

A comparison between calibrated and initial isoline pattern of the vertical resistance, c_2 , of the layer between middle and lower aquifer is given in Fig. 6.2. The calibrated pattern is in better agreement with the extension of the Cromerian clay than the initial one.

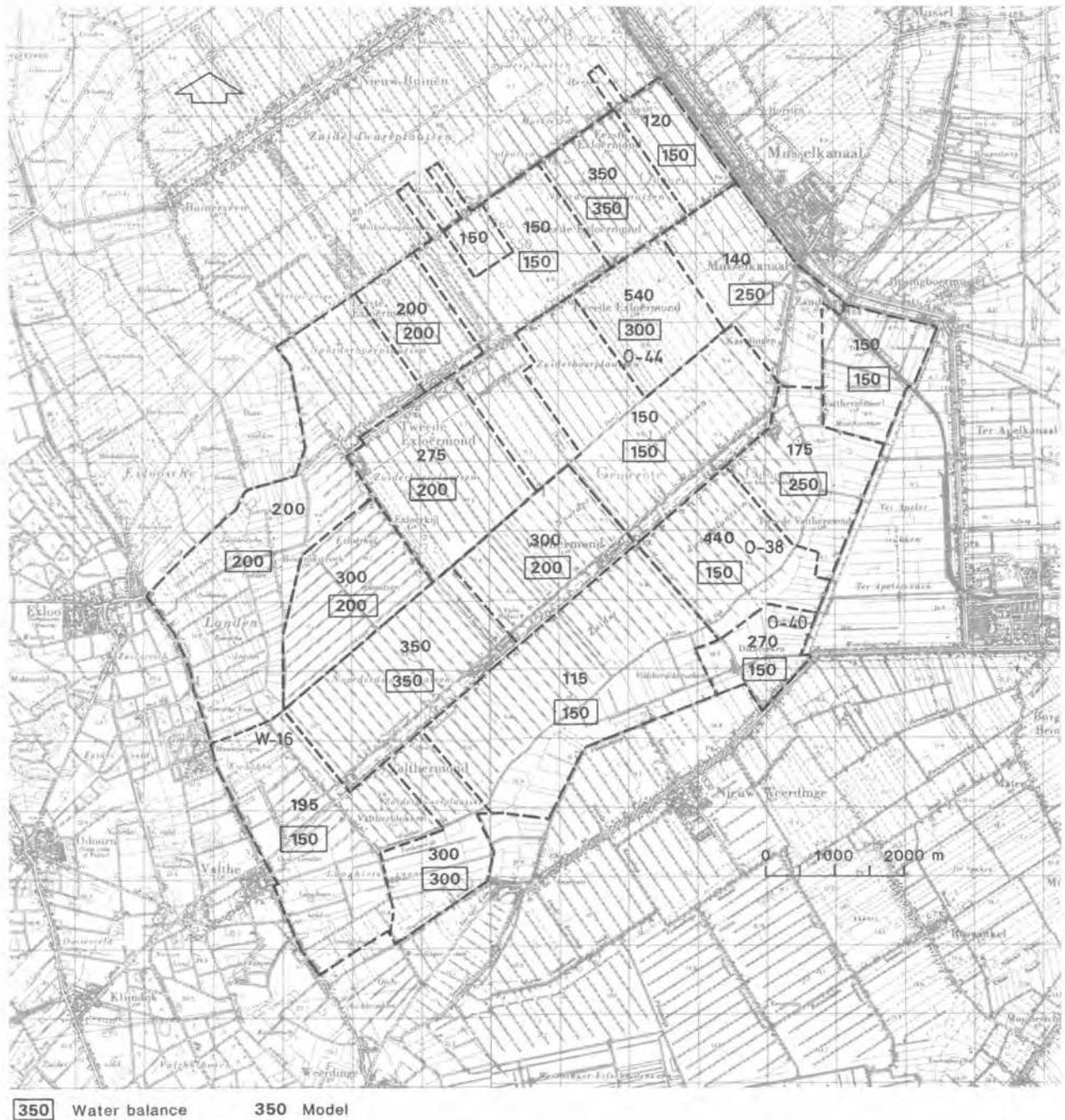

Fig. 6.3. Comparison between the T -values per section calibrated with FEMSATS, and the T -values derived from field data

In principle, when calibrating, T-values should be changed per nodal point. There were, however, not enough field data to do so. Hence, changes were only tried per section. In the field a considerable variation in T-value may occur within a section.

In Fig. 6.3 the calibrated and initial T-values per section are compared. The most important changes were:

- in section W-16 T has been increased from 150 to 195 days;
- the T-value of section O-44 has been increased from 300 to 540 days. This higher value was due to badly maintained 'wijken';
- the T-value of section O-38 has been increased from 150 to 440 days. This value seems rather high because the drainage situation in this section is rather good;

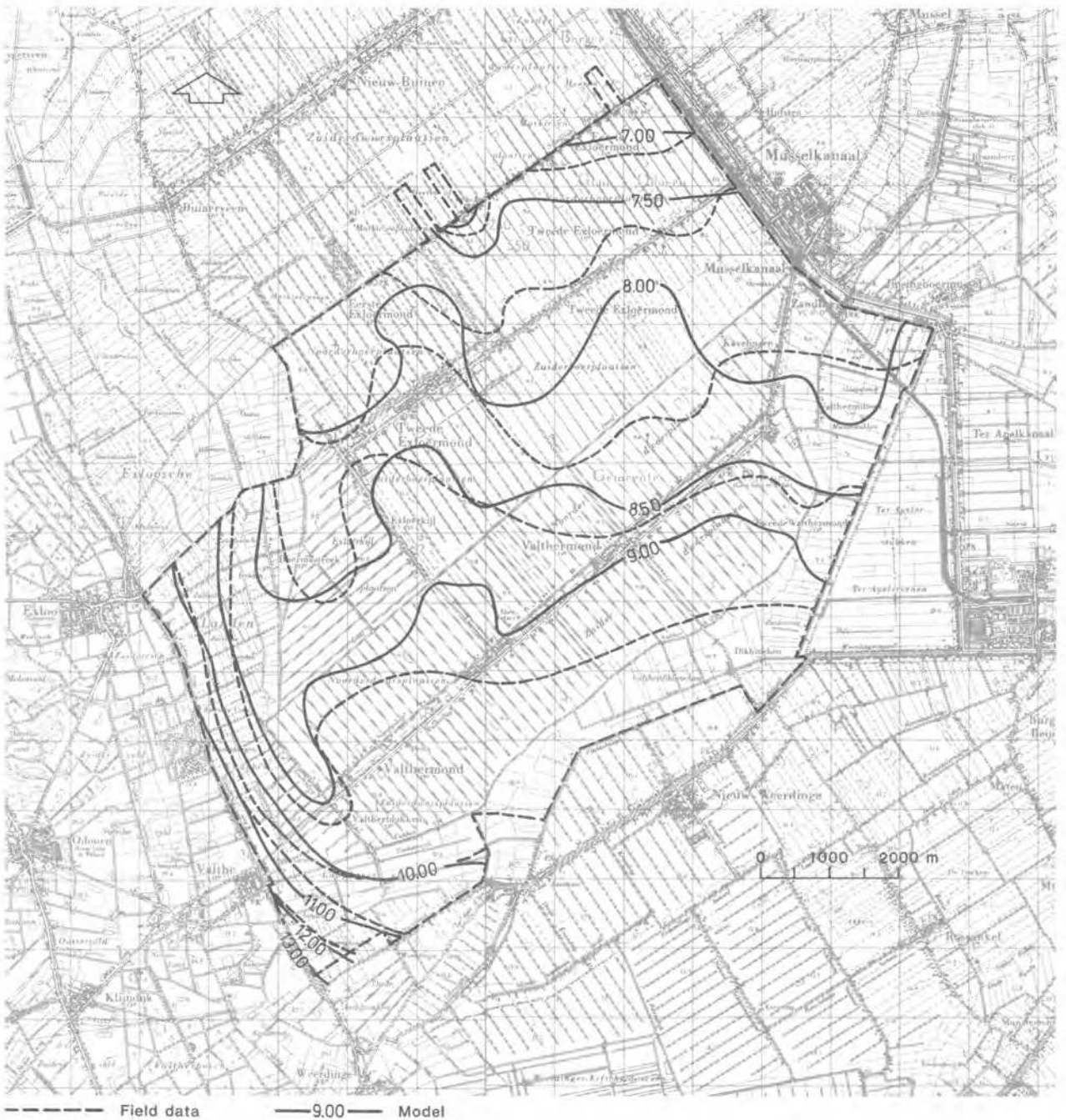

Fig. 6.4. Contour lines of phreatic groundwater levels simulated with calibrated parameters and the pattern derived from field observations

- the increase of the T-value of section 0-40 from 150 to 270 days seems reasonable, because the density of ditches in this section is low.

With the adjusted values of c_1 , c_2 and T-values the piezometer observations and simulated values in the three aquifers is rather good, as can be seen in Figs. 6.4, 6.5 and 6.6. The simulated pattern of the phreatic surface is smoother than the one derived from field observations. This may be due to the fact

that in the observed values local differences in height of the ground surface may have played a role.

The number of piezometers in the middle and lower aquifer was too low to construct a pattern from field observations. The observed data fit very well, although one piezometer in the vicinity of the 10.00 m-isoline shows only values for h_2 and h_3 of 9.52 m and 9.53 m, respectively.



Fig. 6.5. Contour lines of h_2 -values simulated with calibrated parameters and field observations

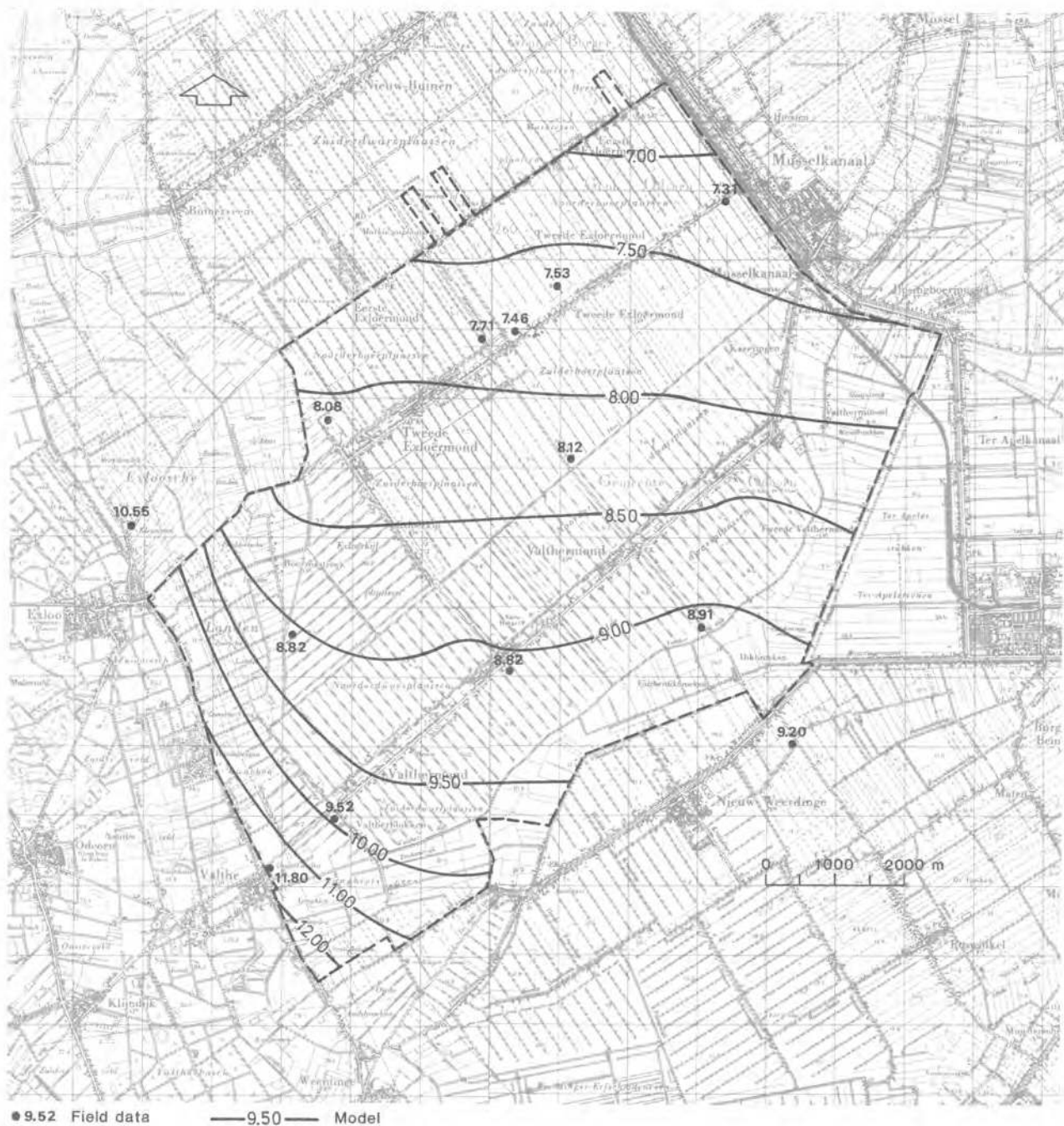

Fig. 6.6. Contour lines of h_3 -values simulated with calibrated parameters and field observations

By means of a sensitivity analysis the influence of changes in parameter values on model results was systematically investigated. All KD , c and T -values were reduced and doubled. As an example the effect of these changes on the average height of the phreatic surface per section is given in Table 6.1. A more detailed description of the results of calibration and sensitivity analysis with FEMSATS is given by SMIDT (1984).

The effects of changes in K_1D_1 and K_2D_2 are of

minor importance. The influence of K_3D_3 is only of some importance in the western part of the area. This can be explained by the relatively high gradients in hydraulic head present there. With a fixed hydraulic head along the western boundary a lower K_3D_3 -value means less boundary flow and consequently lower phreatic surfaces (and vice versa).

The drainage resistance has the most pronounced effect throughout the area. Lowering of T with only 25% mostly results in considerable lowering of h_F ,

Table 6.1. Results of a sensitivity analysis with respect to changes in average height of the phreatic surface per section (m) compared with the value in the reference run

Section	KD ₁		KD ₂		KD ₃		T		c ₁		c ₂	
	0.5	2.0	0.5	2.0	0.5	2.0	0.75	2.0	0.5	1.5	0.5	2.0
W-14A	0.00	0.00	0.00	0.00	0.00	0.00	-0.03	0.10	0.01	-0.01	0.00	0.00
W-14B	0.00	0.00	-0.01	0.00	-0.04	0.03	-0.10	0.28	0.03	-0.02	0.00	-0.01
W-16	0.00	0.01	0.01	0.01	-0.04	0.05	-0.19	0.29	0.05	-0.03	0.01	-0.01
W-18	0.00	0.00	-0.01	0.01	-0.05	0.06	-0.10	0.28	0.00	-0.01	0.00	-0.01
W-20	0.00	0.01	-0.01	0.01	0.00	0.00	-0.05	0.15	0.02	-0.01	0.01	-0.01
W-22	0.00	-0.01	0.01	-0.02	0.00	-0.01	-0.04	0.13	-0.02	0.01	-0.01	0.00
W-24	-0.01	-0.01	-0.01	0.00	-0.06	0.06	-0.15	0.48	-0.01	-0.01	0.00	-0.02
W-26	0.00	0.00	0.00	0.01	-0.05	0.08	-0.14	0.50	-0.02	0.01	0.00	0.01
M-22	0.00	0.01	0.00	0.01	0.00	0.00	-0.05	0.22	0.00	0.00	0.01	0.00
M-24	0.00	0.00	0.01	0.00	0.00	0.01	-0.11	0.41	0.00	0.01	0.00	0.00
M-26	0.00	0.00	0.00	0.00	-0.01	0.01	-0.05	0.16	0.00	0.00	0.00	0.00
M-28	0.00	0.00	0.00	0.00	0.00	0.00	0.00	0.00	0.00	0.00	0.00	0.00
M-34	0.00	0.00	0.00	0.01	0.00	0.00	-0.07	0.29	0.00	0.00	0.01	0.00
M-36	0.00	0.00	0.00	-0.01	0.00	-0.01	-0.10	0.36	-0.01	0.00	0.00	0.00
O-32	0.00	0.00	0.00	0.00	0.00	0.00	-0.02	0.06	0.00	0.00	0.00	0.00
O-34	0.00	0.00	-0.02	0.02	0.00	0.00	-0.05	0.19	0.00	0.00	0.00	0.00
O-36	0.00	0.00	0.00	0.00	0.00	-0.01	-0.05	0.14	0.00	0.00	-0.01	0.00
O-38	0.00	-0.01	0.03	-0.04	0.03	-0.04	-0.07	0.22	-0.02	0.01	-0.03	0.03
O-40	0.00	0.00	0.00	0.00	0.01	-0.00	0.02	-0.08	0.01	0.01	0.00	0.01
O-42	0.00	0.00	0.02	-0.01	0.01	0.00	-0.06	0.19	0.00	0.01	0.00	0.01
O-44	0.01	-0.01	0.03	-0.04	0.01	-0.01	-0.14	0.43	-0.01	0.01	-0.03	0.02
O-46	0.00	0.00	0.00	0.01	0.00	0.00	-0.03	0.10	0.00	0.00	0.00	0.00

especially in the western part. Again, this effect can be explained by the type of boundary condition used for calibration, i.e. fixed hydraulic heads. Lowering of T in a period of precipitation surplus means a lower height of the phreatic surface. As a result, the boundary flux will increase. The high sensitivity of the model results for changes in T-values implies on one hand that this parameter can be calibrated quite well but on the other hand that it is necessary to determine this parameter with relatively high accuracy.

The influence of changes in c₁ and c₂-values is less than expected. This means that the situation used for calibration was not very suitable for a proper calibration of these resistances. It is to be expected that in a situation of water withdrawal from the lower aquifer the c₁ and c₂-values could be calibrated much better because of larger changes in head. The model FEMSATS, however, was only used to investigate the effects of relatively small changes in the surface water level and hence small changes in heads in the aquifers on the regional groundwater flow pattern.

6.3. VERIFICATION OF FEMSATS

Because for verification of FEMSATS no second period with negligible changes in storage and sufficient field data was available, a less direct and less formal way of verification was carried out by comparing long term differences on observed and simulated re-

Table 6.2. Comparison between average regional fluxes \bar{v}_a (mm·d⁻¹) per section, derived from water balances and obtained by simulation with SWAMP, over the period 6-2-1978 to 5-10-1981

Section	Observed	Simulated	Observed minus simulated	Efficiency factor R _e
W-14	-	0.6	-	
W-16	1.8	1.4	0.4	
W-18	0.1	0.3	-0.2	
W-22	-0.9	-0.7	-0.2	
W-24	-0.4	0.4	-0.8	
W-26	-0.7	-0.2	-0.5	
Western part	0.5	0.5	0.0	
M-22	-	-0.2	-	
M-24	-0.3	-0.3	0.0	
M-26	-0.3	0.0	-0.3	
M-34	-0.5	-0.2	-0.3	
M-36	-0.7	-0.5	-0.2	
Middle part	-0.4	-0.2	-0.2	
O-32	-	0.8	-	
O-34	-	0.2	-	
O-36	-0.7	0.2	-0.5	
O-38	-1.1	-0.6	-0.5	
O-40	-1.0	-0.4	-0.6	
O-42	-0.6	-0.2	-0.4	
O-44	-0.7	-0.5	-0.2	
O-46	-0.6	0.0	-0.6	
Eastern part	-0.6	-0.2	-0.4	
Whole region	-0.2	0.1	-0.3	0.61
Whole region, calculated from boundary flux	0.3			

gional flow per section.

The calibrated saturated flow model FEMSATS was used to establish the functional relationship $\bar{v}_a = f(\bar{h}_f, \bar{h}_o)$ per section required for the lower boundary condition of the unsaturated flow part of SWAMP. Next SWAMP was used to simulate per section the effects of different alternatives of surface water management. The results of these simulations are dealt with in Chapter 9. One of the outcomes is a time series of the regional flux, \bar{v}_a , per section. From this series the mean \bar{v}_a during the period for which water balance measurements were available, have been selected. In Table 6.2 these values are compared with the corresponding water balance data. For this purpose, the water balance equation is applied in the following way:

$$\bar{v}_a = \Sigma P - \Sigma E + \Sigma V_{O,W} \quad (6.2)$$

The cumulative precipitation, ΣP , has been taken from the neighbouring KNMI-station Nieuw-Buinen, the actual evapotranspiration, ΣE , was derived from the water balance of the whole area and $\Sigma V_{O,W}$ is the measured total discharge per section.

The agreement between observed and simulated data is rather poor, especially for the eastern part of the area. Possible reasons are the low accuracy of the measured discharges in periods of low discharge rates (weirs are not ideal for measurement) and a systematic underestimation of the measured discharges. The first reason is supported by the fact that the part with the lowest discharges, i.e. the eastern part, shows the highest discrepancy. The second reason is supported by the net regional flux in Table 6.2, calculated from the boundary fluxes of the saturated groundwater system. This figure results from head gradients multiplied with the transmissivity and its accuracy is within $0.2 \text{ mm} \cdot \text{d}^{-1}$.

6.4. VERIFICATION OF THE UNSATURATED FLOW PART IN SWAMP

6.4.1. Verification with lysimeter data

With the model SWAMP the effects of surface water management on the actual transpiration of potatoes was simulated. Hence, a proper way of verification is to feed the model with measured meteorological data and observed surface water levels and to compare the simulated actual transpiration with the transpiration derived from field data. For this purpose, four non-weighable lysimeters were installed in the experimental field (for the location, see Fig. 3.8). By means of an automatic device these lysimeters had the same

Table 6.3. Water balance data from lysimeters (observed) and simulated for the period 29-4-1980 to 1-10-1980. All figures are in mm

	Observed	Simulated
ΣP_n	399	399 (input)
ΣE_t		240 ($E_{t,p} = 249$)
ΣE_s		67 (input) ($E_{s,p} = 149$)
$\Sigma (E_t + E_s)$	374	307
$\Sigma W_r + \Delta W_s$	-70	-35
ΣV_b	-95	-127

groundwater level as their surroundings (FEDDES, 1971). In order to measure the changes in soil water content, tensiometers were installed. Evapotranspiration was obtained as a balance term.

In Table 6.3 the measured water balance terms for the period 29-4-1980 to 1-10-1980 are compared with the corresponding simulated values. The 67 mm difference between observed and simulated E_t and E_s is rather large. Possible reasons are:

- the amount of net precipitation is derived from $\Sigma P_n = \Sigma P - \Sigma E_i - \Sigma f_i$. Rainfall was obtained from a pluviometer, ΣE_i computed from SWATRE and Σf_i was set equal to zero, because of the high infiltration capacity of the soil. Especially this latter assumption is questionable because of the heavy showers occurring during this growing season;
- the simulated E_t is bounded by the amount of $E_{t,p}$. A difference of 9 mm has been simulated because of very wet conditions during part of the growing season;
- the simulated E_s is input for the model and has been calculated with SWATRE. As was already described in Chapter 5, for the conversion from potential soil evaporation rate, $E_{s,p}$, to E_s empirical relationships are used in this model.

The most important conclusion from the figures in Table 6.3 is that there has been hardly any reduction in transpiration. This outcome is supported by field observations. Hence, verification of SWAMP, using the lysimeter data of 1980, means a verification of the upper boundary conditions, i.e. the magnitudes of $E_{t,p}$ and E_s and not a verification of simulated reduction of $E_{t,p}$. Therefore SWAMP could not be verified with lysimeter data.

6.4.2. Verification with thermal infrared images

The regular data collection period ended in September 1981 without the occurrence of any significant

reduction in transpiration. In 1982 such a period occurred and therefore on 4 August 1982 an Infra-Red Line Scanning (IRLS) flight was performed above the area.

Remote sensing techniques can be very useful to characterize the regional pattern of reduction in evapotranspiration. The theoretical background to convert heat images into instantaneous evapotranspiration values and the procedure to obtain 24-hr values of evapotranspiration are described by SOER (1980). A complete description of obtained pictures and the analysis of them are given in NIEUWENHUIS et al. (1985).

The relationship between temperatures and 24-hr evapotranspiration of potatoes and sugar beets has been determined by means of the TERGRA-model (SOER, 1977, 1980). The crop roughness z_0 is set equal to 3.5 cm corresponding to a crop height of 60 cm (NIEUWENHUIS and PALLAND, 1982). The data offered the possibility to classify the reduction in evapotranspiration into four classes, viz. extremely high (>60%), considerable (25-60%), some (10-25%) and negligible (<10%) reduction, corresponding with I through IV, respectively in Fig. 6.7.



Fig. 6.7. Regional pattern of reduction in evapotranspiration of part of the study area and its surrounding, derived from heat images

Patterns shown in Fig. 6.7 have been determined only from the temperatures of the potato and sugar beet plots. It should be remarked that, by classifying, a lot of detailed information was lost.

In the Hondsrug region with groundwater depths of more than 5 m below soil surface large reductions in evapotranspiration are found. The seepage zone east of the Hondsrug clearly manifests itself as a zone where reduction in evapotranspiration is negligible. More towards the east reductions vary between those found on the Hondsrug and in the seepage zone. In this area reductions coincide more or less with the elevations of the soil surface. Differences in elevation are related with differences in soil mapping units and consequently with differences in soil physical units while depth of the surface water level plays a role too. With the aid of the pattern of reduction in transpiration, the map of soil physical units and the elevation map an estimation of the average reduction in evapotranspiration on 4 August could be established for four typical situations. These four situations were then simulated with SWAMP during the year 1982. The simulated reductions in evapotranspiration are compared with reductions derived from the heat images (Table 6.4). The agreement is very good, except for soil physical unit I where the simulated reduction in evapotranspiration is too high. This is probably caused by the choice of the $K(h_p)$ -relationships for the peaty subsoils. They were calculated from granular analysis and organic matter content, but this validity for soil layers with high organic matter content could not be verified with experimental data.

The most common soil physical units between the sandy ridges are VII and XI (improved). Due to differences in soil physical properties caused by soil improvement and differences in elevation the heat images show much variation. Therefore the reduction in evapotranspiration derived from the heat images varies between 30 and 60%.

A small region with peaty soils was considered more closely. In this area the influence of soil surface elevation on crop evapotranspiration reduction was evident. Improved peaty parcels on the highest parts showed a reduction of 70% while the same soil in the lower places showed a reduction of 40%. The reductions in evapotranspiration, calculated with SWAMP, are 70% and 15% respectively.

The reduction in evapotranspiration of an improved soil with a surface level of 9.40 m above

Table 6.4. Comparison between reduction in evapotranspiration of potatoes with complete soil cover on 4 August 1982, derived from infrared heat images with the reduction calculated with the SWAMP-model for four situations

Location	Soil physical and hydrological properties				Reduction of $E_{t,p}$ (%)	
	soil physical unit	root depth (cm)	seepage ($\text{mm}\cdot\text{d}^{-1}$)	surface water level during summer (cm below surface)	heat images	SWAMP
'Hondsrug'	VIII	20	-1.0	500	90	80
Seepage zone adjacent to the 'Hondsrug'	I	30	1.0	90	20	50
Sandy ridges	VIII	20	0.0	130	70	80
Between sandy ridges	VII/XI	40/20	0.0	90-130	30-60	40-60

Ordinance Datum (1.00 m above summer surface water level), obtained with SWAMP, was 40% while the non-improved profile under the same circumstances gave 70% reduction, both in agreement with the heat image.

In another part three leveled and drained parcels with the surface level about 0.80 m above summer surface water level, and parcels with a surface level more than 2.00 m above summer surface water level were present. They gave a reduction in evapotranspiration from SWAMP of 15% and 80% respectively. The hydrological situation for the latter can be compared with the 'Hondsrug' area for which in Table 6.4 a reduction in evapotranspiration of 80% is given.

From the comparison between reductions in evapotranspiration derived from infrared heat images and reductions derived from SWAMP, the following conclusions can be drawn:

- the simulated effects of differences in elevation agree with the results of the heat images. This is a good indication for a proper hydraulic conductivity of the subsoil;
- the effects of soil improvement on soil physical properties are derived from a number of assumptions (see Chapter 4). Validation with heat images indicate that these assumptions are reasonable;
- the unsaturated hydraulic conductivity of unit I is probably underestimated by the Bloemen method.

In general, heat images proved to support the results obtained from the SWAMP-model.

Table 6.5. Most important differences and agreements between the models SWAMP and SWADRE (Van Walsum and Van Bakel, 1983)

Description	SWAMP	SWADRE
Discretization of soil profile	root zone + subsoil	20 compartments, each with a thickness of 0.10 m
Calculation of groundwater flow	quasi-steady-state	non-steady-state
Calculation of surface water level	from water balance of 'wijk' and secondary system	from water balance of 'wijk'
Determination of target level	from groundwater depth and soil water in root zone	ibid
Calculation of $E_{t,p}$	boundary condition	from meteorological data and crop parameters
Calculation of reduction in $E_{t,p}$	$E_t = f(W_r, E_{t,p})$	$E_t = \sum_{i=1}^I f(h_p, E_{t,p})$ (I is number of compartments in root zone)
Calculation of h_f	from water balance of subsoil and μ_s	from water balance of whole soil profile
Lower boundary condition	$v_b = v_d + v_a$ $v_d = f(h_f^*, h_o^*)$ $v_a = f(h_f^*, h_o^*)$	$v_d = v_d + v_a$ $v_d = f(h_f, h_o)$ $v_a = f(h_f)$

6.5. COMPARISON OF SIMULATION RESULTS OF SWAMP AND SWADRE

Although comparison of results of a model with those of another model cannot be classified as a real verification, the confidence in a model increases when both models give similar results. SWATRE was verified for many situations (see e.g. FEDDES et al., 1978 and De GRAAF and FEDDES, 1984). In these applications, however, the modeled system was restricted to the unsaturated zone only. To simulate the effects of water supply to the whole cut-over peat area (WERK-GROEP WATERAANVOER, 1983) SWATRE was extended with modules for surface water management and for water flow in the surface water system. The starting points for these two modules were nearly identical with those used in SWAMP. This extended version will be denoted as SWADRE.

The agreements and differences between SWAMP and

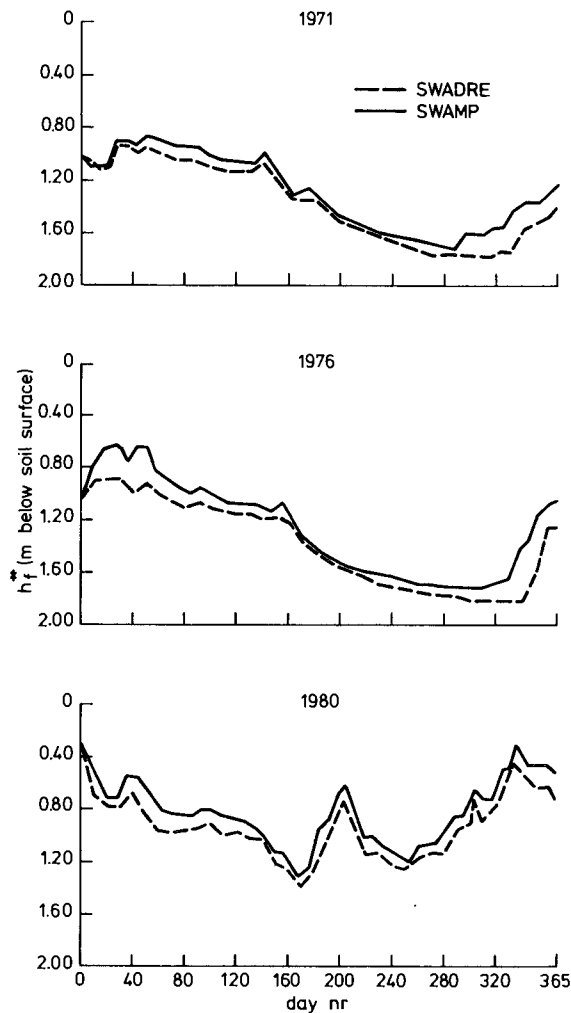

Fig. 6.8. Time series of groundwater depth, h_f^* , during 1971, 1976 and 1980 simulated with SWATRE and SWAMP, respectively

SWADRE are given in Table 6.5. The main difference is that the former is quasi-steady, whereas SWADRE uses a non-steady state-approach. Further differences are the calculation of reduction in transpiration and of the height of the phreatic surface. For a more detailed description of SWADRE, see Van WALSUM and Van BAKEL (1983) and KEESMAN and Van BAKEL (1985).

Both models were applied on potatoes growing on soil physical unit XI (improved iWp) and with the meteorological data of the period 1971-1982. In Fig. 6.8 the time series of the depth of the phreatic surface of the years 1971 (dry year), 1976 (extreme dry year) and 1980 (wet year), calculated with both models, are compared. The agreement is very good. The differences during winter periods can be explained by small differences in simulated open water level. Of importance is that the lowering of the phreatic surface in the dry years 1971 and 1976 are almost identical. This fact is a strong evidence that the quasi-steady-state approach of the unsaturated groundwater flow in SWAMP is acceptable. In autumn the rise of the phreatic surface, calculated with SWAMP, starts earlier than with SWADRE.

Even more important than a good agreement between groundwater depth is the agreement between the effects of surface water management. For that purpose both models were fed with two different ways of surface water management, viz. 1) conservation and 2) water supply with a maximum rate of $1.5 \text{ mm} \cdot \text{d}^{-1}$. The results are given in Table 6.6. In general, the correspondence between the results of both models is good, especially in case of water supply. Only during the dry year 1976 SWADRE gives a significantly higher value for E_t under conservation. The effect of water supply, calculated as the difference in E_t , is also shown. SWAMP clearly shows a higher effect of water supply in dry years. This difference can partly be explained by the fact that in SWAMP the water supply only depended on the water balance of the surface water system. As soon as the surface water level in spring dropped below a particular target level, water supply started. In the SWADRE-model the water supply was also dependent on the amount of water in the root zone.

The average seasonal amounts of water supply needed, $\overline{\Sigma v_{o,p}}$, were 57 mm and 71 mm for SWADRE and SWAMP respectively. The average efficiencies of water supply, $\overline{e_w}$, are 10.5 and 13.2% for SWADRE and SWAMP respectively. The efficiency calculated with SWAMP is somewhat higher mainly because the increase in transpiration is significantly higher ($9.4 \text{ mm} \cdot \text{a}^{-1}$ compared with $6.0 \text{ mm} \cdot \text{a}^{-1}$).

From the comparison between the simulated results

Table 6.6. Comparison of yearly values of E_t , simulated with the extended SWATRE-model and with the SWAMP-model, for two alternatives of surface water management

Year	$E_{t,p}$ (mm·a ⁻¹)	Conservation		Maximum supply 1.5 mm·d ⁻¹		Effect of water supply (mm·a ⁻¹)	
		E_t calculated with		E_t calculated with		SWADRE	SWAMP
		SWADRE	SWAMP	SWATRE	SWAMP		
1	2	3	4	5	6	7 (= 5-3)	8 (= 6-4)
1971	329	302	297	313	316	11	19
1972	295	291	294	290	294	-1	0
1973	298	282	276	284	280	2	4
1974	301	298	298	300	300	2	2
1975	336	294	293	315	314	21	21
1976	338	299	284	328	328	29	44
1977	274	265	257	267	268	2	11
1978	275	273	270	274	273	1	3
1979	250	248	249	248	249	0	0
1980	237	227	227	221	222	-6	-5
1981	248	249	248	250	248	1	0
1982	308	282	277	292	290	10	13
Mean	295	275.7	272.5	281.7	281.9	6.0	9.4
Average seasonal water supply, $\overline{\Sigma v}$ (mm)				57	71		
Average supply efficiency, $\overline{e_w}$ (%) _{O,P}				10.5	13.2		

of SWADRE and SWAMP the conclusion can be drawn that their behaviour is similar. Evidently, the quasi-steady-state approach used in SWAMP is permissible.

The conclusion that SWAMP is suitable for simulating the effects of different ways of surface water management is risky, because a number of simplifications and assumptions are used in both models. Important simplifications in this respect are ignoring hysteresis and non-uniformity in horizontal direction that may cause a lower capacity to store precipitation surplus in the unsaturated zone and a constant thickness of the root zone, independent of crop growth and soil water conditions. The most important assumption is that the relation between soil water pressure head and reduction in transpiration is independent of the growing stage.

6.6. REGIONAL GROUNDWATER FLOW IN SWAMP

In Chapter 5 a method to take into account the effects of regional groundwater flow in SWAMP has been discussed. By running FEMSATS with different values for the flux through the phreatic surface, v_f , and open water level, h_o , the relation $v_a = f(h_f^*, h_o^*)$ was established. It should be reminded that v_f is dependent on regional groundwater flow. As already pointed out one may expect differences in E_t from differences in soil water availability. Because there is a regional pattern of soil mapping units, it is to be expected that there will be systematic differences in v_f too.

If a stationary model is applied, a unique rela-

tionship $v_f = f(h_f^* - h_o^*)$ is used. A consequence of this is that the calculated values for $h_f^* - h_o^*$ for high values of v_f are overestimated. This causes a frequency distribution of $h_f^* - h_o^*$ that is different from a stationary model (see e.g. WESSELING, 1969). The difference depends on the time constant τ . If τ would be the same throughout the area, this phenomenon would not cause a distortion of the correlation between heights of the phreatic surface on different places, but there exists a spatial variability in T and μ and hence in τ .

The variation with time of the surface water level is taken the same in all sections. In practice, the surface water level in a particular section will be manipulated according to the groundwater depth in that section. Hence, the surface water levels may differ in different sections, their fluctuations will differ both in phase and amplitude.

Summarizing one can say that differences in v_f , τ and h_o^* between the sections are caused by differences in E_t , T and surface water management. To find out in how far these differences influence the final results, cases with extreme differences in soil water availability, T and h_o have been simulated by SWAMP over the period 1971-1982.

As extremes for soil water availability the soil physical units XI (improved iWp) and VIII (Hn21) that give a long term reduction in potential transpiration of 8% (24 mm) and 25% (73 mm), respectively, have been compared. Both units have been simulated with exactly the same input data, type of water management, etc. The computed values of h_f^* in unit VIII were used to

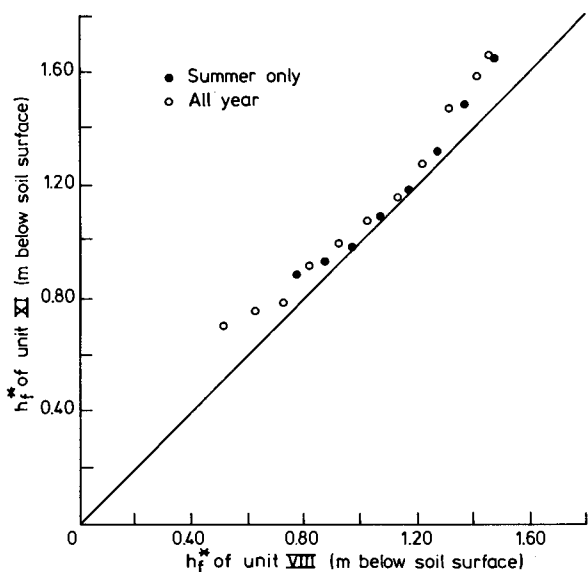

Fig. 6.9. The influence of soil physical unit on simulated daily h_f^* -values of units VIII and XI

derive a frequency distribution. For each frequency class of 10 cm the simultaneously occurring values of h_f^* in unit XI were selected and their mean value computed. These means are plotted in Fig. 6.9 against the means of the frequency classes of unit VIII. In case there is no systematic influence of soil type the points in Fig. 6.9 will fall on the 45°-line. However, as a consequence of the higher storage capacity both the lower and higher values of h_f^* of unit XI fall above this line. In the latter case better capillary rise and consequently higher values of E_t give unit XI a deeper groundwater table than unit VIII.

The effect of a better capillary rise can be taken into account by introducing v_f as a function of h_f^* in case $v_f > 0$ (see Chapter 5). If such a correction is made, the remaining maximum systematic error in h_f^* can be estimated to be 0.05 m. In this estimate, the number of simulations in each class has been taken into account.

For extremes of T , the simulated values of h_f^* of unit XI with $T = 300$ days and with $T = 100$ days have been compared for the period 1971-1982. The surface water level was kept constant at 1.40 m below soil surface, as long as the height of the phreatic surface was above this level. Fig. 6.10 gives the results, obtained as described above. The relation should follow the dashed line in Fig. 6.10, at least at low h_f^* . The simulated values of h_f^* do not obey this relation.

According to the steady-state approach used in FEMSATS, the points for the given T -values should fall on the dotted line in Fig. 6.10 with a slope 1:3

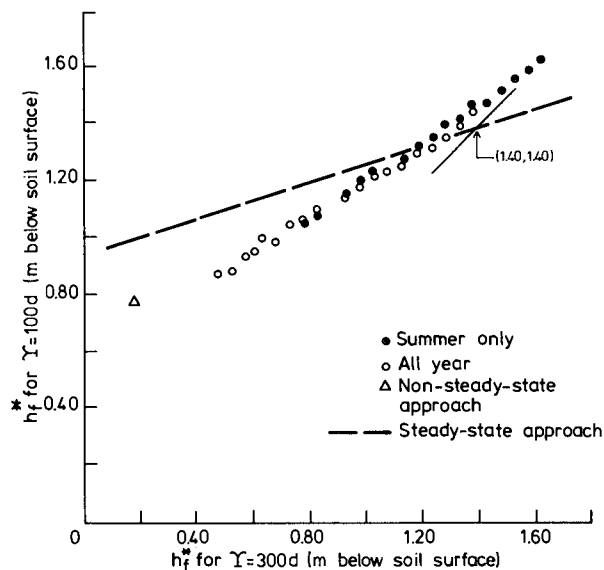

Fig. 6.10. The influence of drainage resistance on simulated daily h_f^* -values of soil physical unit XI with $T = 300$ days and $T = 100$ days. Also depicted are the relationship according to the steady-state theory and one point from the non-steady-state calculations

through the point (1.40, 1.40).

The difference between the steady-state approach and the non-steady-state one used in SWAMP will increase with increasing discharge intensity (WESSELING, 1969).

For Dutch conditions WESTPHAL (1981) established a relationship between the time constant $\tau (= \mu T)$ of the groundwater system and discharge flux for particular recurrence times of the flux. This relationship is given in Fig. 6.11 for a recurrence time of once a year.

With the aid of Fig. 6.11 it is possible to es-

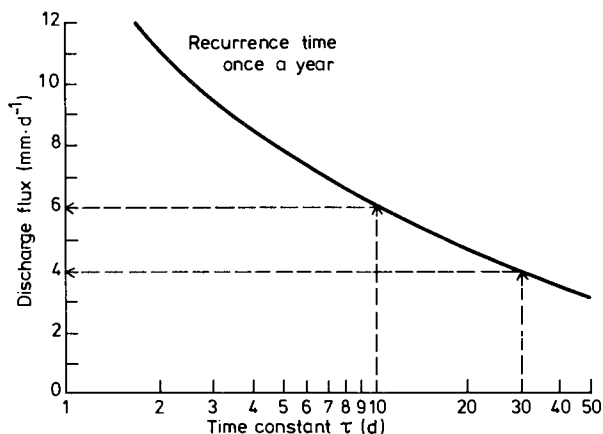

Fig. 6.11. Relationship between time constant of the saturated system and the discharge intensity with a recurrence time of once a year for daily precipitation in De Bilt during 1913-1963 (Westphal, 1981)

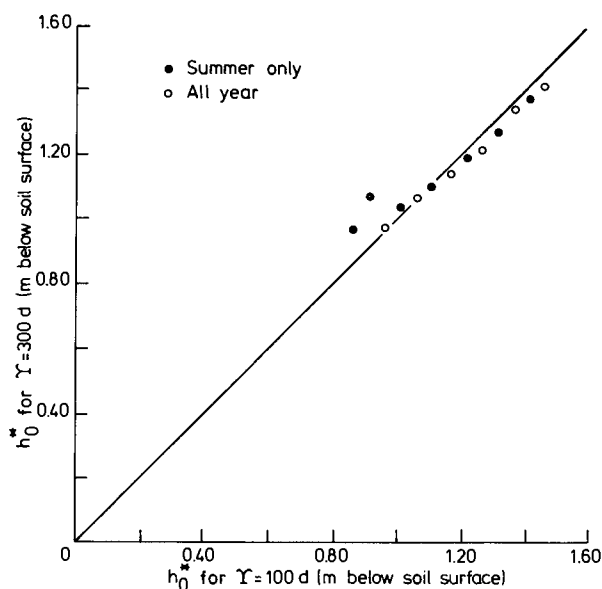

Fig. 6.12. The influence of differences in surface water management in terms of simulated daily h_0^* -values for soil physical unit XI with $T = 100$ days and with $T = 300$ days

establish the theoretical relationship between h_f^* in extreme wet periods for the two cases. With $\mu = 0.10$ and $T = 300$ days τ is 30 days and with $T = 100$ days and $\mu = 0.10$ τ becomes 10 days. The corresponding discharge intensities in Fig. 6.11 are 4.1 and 6.2 $\text{mm}\cdot\text{d}^{-1}$, respectively. For the given T -values the values for $h_f^* - h_0^*$ are -1.23 and -0.62 m respectively. When h_0^* is 1.40 m below soil surface, h_f^* becomes 0.17 and 0.88 m below soil surface respectively. This combination is given in Fig. 6.10 as a result of the non-steady-state approach. It agrees very well with the simulated relationship.

In dry periods with high values of h_f^* the surface water level is assumed to remain at 1.40 m below soil surface as long as there is discharge. In case there is no discharge, the surface water level will further fall and will approximately equal the phreatic level. Thus the points will come close to the 45°-line.

Taking into account the frequencies of the different h_f^* -values, a reasonable estimation of the maximum systematic error in groundwater depth obtained from FEMSATS, is 0.10 m.

Finally the influence of differences in surface water management has been investigated by simulating required surface water levels in case of water supply for two situations: soil physical unit XI with $T = 100$ days and 300 days respectively. Due to difference in drainage resistance, one may expect difference in surface water management. The simulated data for the two cases are plotted in Fig. 6.12. Only for low values of the depth of the surface water level deviations from the 45°-line occur.

From the results mentioned above it can be concluded that the maximum systematic error in h_f^* per section is 0.15 m. Calculations with FEMSATS for sections with an unfavourable ratio between area and length of outer boundary, showed that the effect of a change of 0.15 m in depth of the phreatic surface on the regional flux v_a was $0.24 \text{ mm}\cdot\text{d}^{-1}$. In these calculations the phreatic levels of the surrounding sections were kept constant.

The systematic error of $0.24 \text{ mm}\cdot\text{d}^{-1}$ in v_a is a maximum estimate. In practice the difference in soil profiles is less pronounced. Besides, during summer when effects of surface water management are important, the depth of the phreatic surface is relatively low. Consequently the systematic error caused by differences in drainage resistance is lower too. A final remark in this respect is that the systematic error in v_a is calculated without taking into account feedback effects, i.e. a deviation in phreatic surface causes a change in flux that reduces it.

The final conclusions from the validation is that the conceptual approach of modeling the lower boundary condition of SWAMP is acceptable, keeping in mind other uncertainties and assumptions which are inherent to each modeling process. The results of a sensitivity analysis with SWAMP that will be described in Chapter 8, support this important conclusion.

7. DAY-TO-DAY SURFACE WATER MANAGEMENT AND ESTABLISHMENT OF OPERATIONAL RULES

7.1. CHOICE OF RULES FOR THE DAY-TO-DAY SURFACE WATER MANAGEMENT

The ultimate goal of manipulating surface water levels in an area like 'De Monden' is improvement of the soil water conditions for crop growth. Therefore it is logical to relate the day-to-day surface water management and soil water conditions by means of variables that are determining the latter. From the discussions in Chapter 5 it followed that probably the best choice for these variables are groundwater depth and soil water storage in the root zone.

A mathematical description of the way surface water management is coupled with groundwater depth and soil water storage in the root zone should result in operational rules for the day-to-day surface water management. The latter actually means a frequent change in surface water level and, if water supply from outside is possible, a frequent adjustment of the supply rate in order to obtain the best possible soil water conditions for plant growth.

According to the scheme given in Fig. 5.2 the development of a model starts with a perceptual scheme of the real conditions. Concerning surface water manipulation, one can formulate the following starting-points and assumptions:

- a. Under climatological conditions prevailing in the Netherlands there is a precipitation surplus during winter (October - March) and an evapotranspiration surplus during summer (April - September). In the former period drainage is necessary and the lower the surface water level, the better the drainage. The water delivering capacity of the soil during summer is not always enough to meet evapotranspiration surpluses. Shortages are influenced by depth of drainage and can be reduced by creating high open water levels through activation of sub-irrigation. Hence, the general trend in surface water level will be low during winter and high during summer.
- b. Because of variation in weather conditions the optimal surface water level will often deviate from the general trend. Management of the surface water level should depend on soil and crop conditions and therefore the optimal surface water level will vary continuously.

- c. In principle, the manipulation of the surface water level could be performed automatically by means of sensors that observe conditions like soil moisture, depth of water table and open water level. This method, however, is too sophisticated to apply in practice for the time being. Daily adjustment of all weirs in a waterboard region will be too expensive, because it would ask a daily visit to all weirs and observation points. Therefore an a priori choice of the frequency of adjustment of the most desired surface water level (= target level) must be set. In our case we assumed once in 7 days reasonable.

From the above points it follows that the establishment of operational rules is an optimization problem. The best approach to solve this problem therefore seems to be the use of optimization techniques like linear and dynamic programming. As objective function one could use a min - max objective, i.e. minimizing damage due to waterlogging and maximizing E_t . To be able to apply optimization in the present case a one-to-one relationship between the change in surface water level, Δh_o^* , on one hand and change in groundwater depth, Δh_f^* , and water storage of the root zone, ΔW_r , on the other hand is necessary. In principle, the relationship between Δh_o^* and Δh_f^* can be established like an instantaneous unit hydrograph (IUH). Only with a constant value for the phreatic storage coefficient, μ , and for the drainage resistance, T , the IUH-function would be independent of the value of h_f^* and the mathematics of linear systems is applicable. In practice, however, both μ and T will depend on h_f^* .

The relationship between Δh_o^* and ΔW_r certainly has no one-to-one correspondence. A change in the surface water height changes the groundwater depth, causing a change in capillary rise, v_z , and consequently in W_r . Moreover, v_z depends on W_r and therefore the relationship $\Delta h_o^* - \Delta W_r$ is highly non-linear. Because W_r is also influenced by precipitation and evapotranspiration, it is not predictable. Also dynamic aspects are involved: the history of W_r , and not only its actual value, determines the total transpiration of the crop. Application of an optimization technique therefore has to be rejected.

Another possibility to establish rules for surface water management is a real-time approach. Suppose that the frequency of changing of the target level is once per 7 days. Given the conditions at time t , the best surface water level between t and $t+7$ has to be defined, taking into account the stochastic nature of the weather during that period. The latter can be done by a stochastic model or by the Monte-Carlo method. Using the Monte-Carlo method a representative number of series of weather conditions during t and $t+7$ could be simulated with the SWAMP-model, yielding a frequency distribution of effects of different ways of surface water management. From these results the best possible target level could be chosen. The whole procedure has then to be repeated for the next period. This approach is called real-time approach or predictive simulation.

Because of storage capacity changes in the unsaturated zone the effect of a certain change in surface water level at time t is not restricted to one week. With a time constant $\tau = 20$ days for the whole system in SWAMP, it takes approximately 50 days before 80% of the final effect of an imposed change is reached. Suppose that this is 7 weeks and each week the operator can choose between 3 possibilities: target level + 0.10, 0 and -0.10 meter. When the maximum variation is 0.50 m, the number of possible strategies in these 7 weeks varies between 707 and 1430. For each range a Monte-Carlo simulation has to be carried out, each simulation yielding a frequency distribution of possible effects. Then all the frequency distributions have to be analyzed and it has to be determined which of them are connected with raising, with lowering and with keeping the surface water level constant during the next period. Analysis of these three classes of frequency distributions then has to yield the best choice at time t . Because the amount of work would be far too great for practical application, this approach was also rejected.

The only possibility left is then the empirical approach. A historical series of weather conditions was simulated with SWAMP and by a trial and error procedure the operational rules were improved.

The first step in the empirical approach is modeling the hydraulic properties of weir and inlet structure with respect to surface water level manipulation. The movement of an automatic weir is governed by two electrodes with a fixed height difference of 4 cm (Fig. 7.1). When the surface water level is below s_2 , the weir is raised and when it is above s_1 the weir is lowered. To prevent oscillations, the speed of these movements is restricted.

The weir is modeled as follows. Each week the

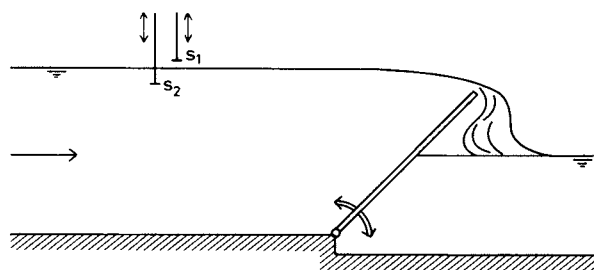

Fig. 7.1. Schematic presentation of the principle of an automatic weir

target level may be set by a shift of s_1 and s_2 . The range between lowest and highest target level is 0.70 m. This range is divided into phases (steps) of 0.10 m: phase 0 stands for the lowest level (winter level), phase 1 is winter level + 0.10 m, etc. Phase 5 (winter level + 0.50 m) is the normal level during the growing season and is called summer level. Phases 6 (winter level + 0.60 m) and 7 (winter level + 0.70 m) are only used in periods with a considerable water shortage in the root zone and sufficient water supply. To maintain these target levels the weir crest level must have a wider range in order to take into account upstream heads under discharge conditions.

The splitting of the target level range into a limited number of phases reduces the number of possibilities, which is favourable for both modeling and practical application.

The general trend in target level, $h_{o,m}^*$, is low in winter and high during summer (Fig. 7.2). In between transition periods must occur, dependent on weather conditions.

During winter, the rule for surface water management has been taken as simple as possible: phase 0 when the groundwater depth, h_f^* , is below a certain level and phase 2 when h_f^* is higher. In this way overdrainage is prevented. Practice showed that during dry winters the groundwater depth can become lower than is necessary for a good workability in spring.

The timing of the beginning of the transition period in spring, t_1 , is very important because a too early rise means extra risks by waterlogging and a too late rise might result in shortages later on. Normally the precipitation surplus decreases at the end of the winter period, hence the depth of the groundwater increases. Therefore the groundwater table can be used as an indicator for the beginning of the transition period. A further operational rule is that the lower the groundwater table the higher the surface water level is set.

During the transition period the surface water

Fig. 7.2. Schematic presentation of possible target level, $h_{o,m}^*$, during the year and the distinction of periods

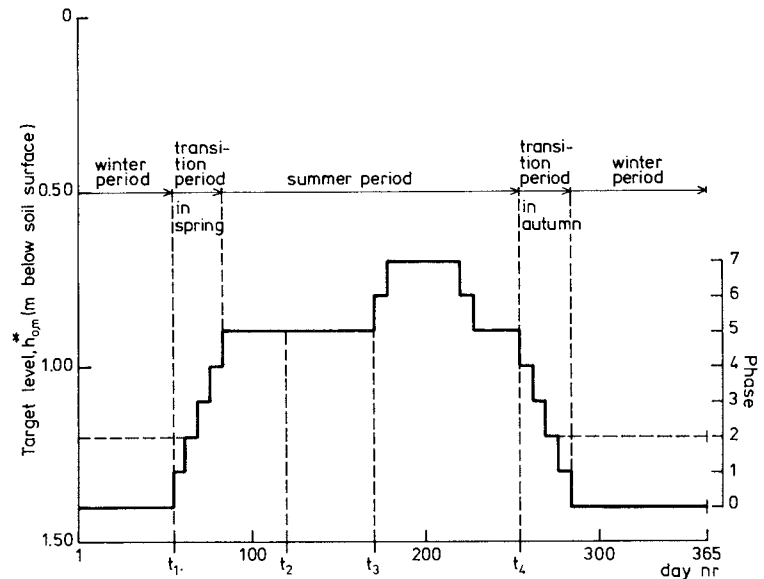

management has been formalized by means of a table that couples the depth of the groundwater table with the target level. An example of such a table is given in Table 7.1. These tables may differ per soil-physical unit and are found by 'trial and error', as will be discussed below. The possibility is included to make a distinction between a more or less constant or dropping groundwater table and a rising one. A groundwater table is considered as rising when its depth in the preceding week decreased 0.05 m or more. In the case of rising groundwater preference is given to a lower target level.

During summer the surface water management has been modeled by coupling the target level with a) the groundwater depth and b) the water storage in the root zone. For this coupling with the groundwater depth the tables for the transition period are used. Although during this period the groundwater table normally is deep, too shallow water tables can occur. By relating the manipulation of the surface water level to the groundwater table the operator

Table 7.1. Example of groundwater depth, h_f^* , and target levels, $h_{o,m}^*$

Groundwater depth h_f^* (m below soil surface)	Phase	Target level $h_{o,m}^*$ (m below soil surface)
>0.60	1	1.30
>0.70	2	1.20
>0.80	3	1.10
>0.90	4	1.00
>1.00	5	0.90
>1.10	6	0.80
>1.10	7	0.70

can react on high or rapidly rising water tables by lowering the surface water level.

As an indicator for the water storage in the root zone the water deficit in the root zone, $W_{r,d}$, has been taken:

$$W_{r,d} = W_{r,e}(1.00) - W_r \quad (\text{mm}) \quad (7.1)$$

where $W_{r,e}(1.00)$ is the water storage in equilibrium with $h_f^* = 1.00$ m and W_r the actual water storage. For phases 4, 5, 6 and 7, $W_{r,d}$ must exceed certain values, as is illustrated in Table 7.2. The reason for this is that high surface water levels give a higher risk of waterlogging after heavy rainstorms. As long as there is a storage possibility in the root zone, this risk is small. Phases 6 and 7 are only allowed after $t = t_3$, which is fixed at 1 July.

In autumn, too early lowering of the surface water level may result in a lower transpiration. If the start is too late, it may result in wetness during harvesting. In the model t_4 depends on $W_{r,d}$, as is illustrated in Table 7.3. This table is also pro-

Table 7.2. Example of water deficit in the root zone during the growing season, $W_{r,d}$, and target levels, $h_{o,m}^*$

Water deficit (mm)	Phase	Target level (m below soil surface)
$W_{r,d} > 10$	4	$h_{o,m}^* = 1.00$
> 20	5	$= 0.90$
> 30	6,7	$= 0.80$ and 0.70

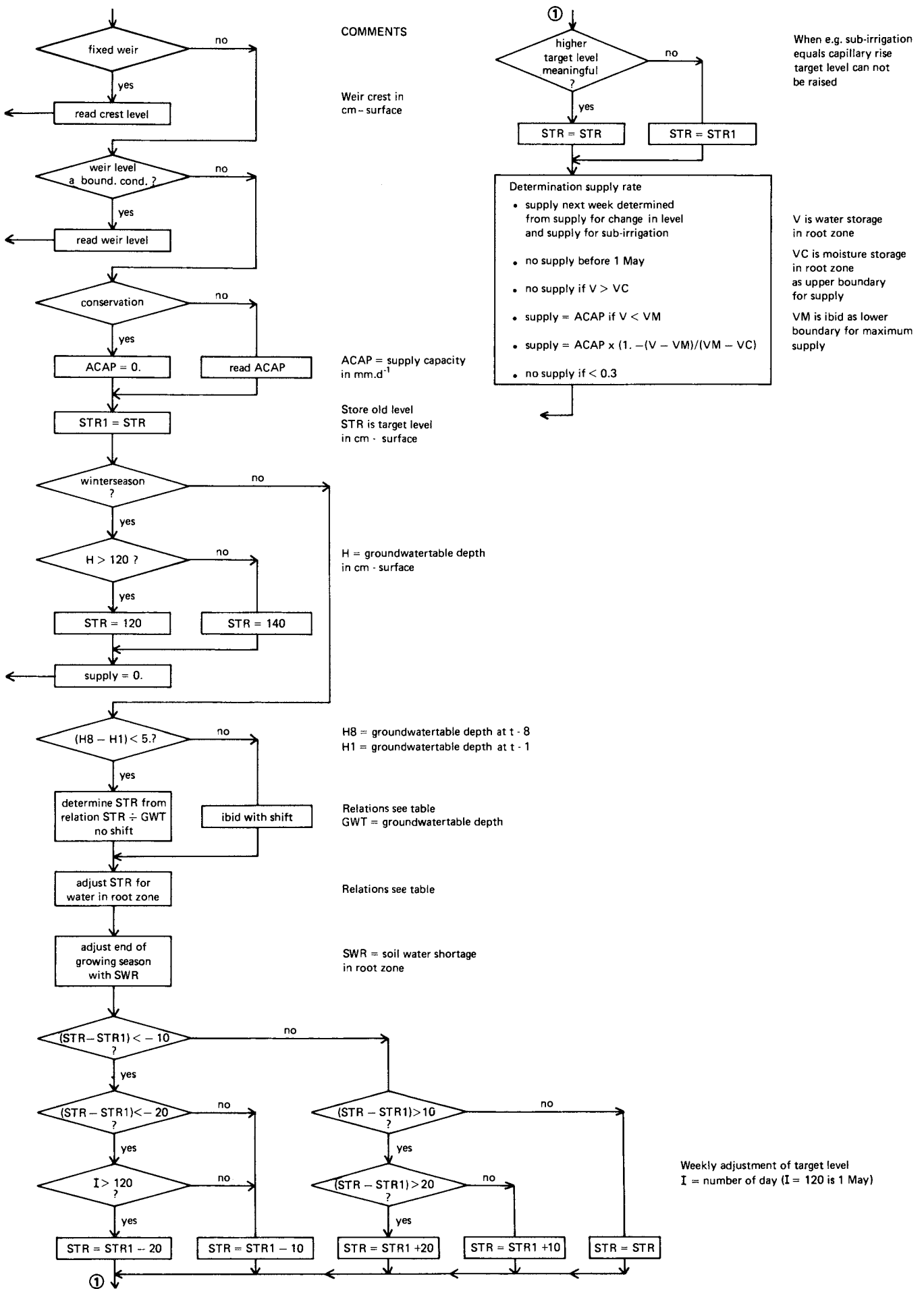

Fig. 7.3. Flow chart of subroutine MANAGEMENT of the SWAMP-model

Table 7.3. Example of the dependency of the beginning of the transition period in late summer, t_4 , on the simulated water deficit in the root zone, $W_{r,d}$

$W_{r,d}$	t_4 (day nr.)
<10	250 (5 September)
<20	270 (25 September)
<30	280 (5 October)
>30	290 (25 October)

duced by 'trial and error'.

The operational rules for the surface water level discussed so far have been purely based on hydrological grounds. Running a model with these operational rules may result in large jumps in target level. In reality, this may cause too high flow velocities and hence erosion of the sidewalls of the watercourses. Therefore the change in target level is limited to 0.10 m a time, except when the change according to the above rules is 0.30 m or more. In that case the change is 0.20 m a time.

Operational rules set for the inlet structure are as follows. Water supply is only possible after $t = t_2$ (see Fig. 7.1), which is a priori fixed at 1 May. The maximum supply rate, s'_m , is made dependable on $W_{r,d}$ as follows:

$$s'_m(t) = 0 \text{ if } W_{r,d} < w_1 \quad (7.2)$$

$$s'_m(t) = s_m \text{ if } W_{r,d} > w_2 \quad (7.3)$$

$$s'_m(t) = s_m \{1 - (w_2 - W_{r,d}) / (w_1 - W_{r,d})\} \text{ if } w_1 \leq W_{r,d} \leq w_2 \quad (7.4)$$

where w_1 and w_2 are fixed amounts. In this way a gradual increase or decrease in supply rate can be reached.

At time t the water supply rate for the period between t and $t+7$ is found from the water balance of the surface water system:

$$v_{o,p}(t) = \min \left[s'_m(t), \left\{ (v_d(t) + v_d(t+7)) / 2 + \{h_{o,t}^*(t) - h_{o,m}^*(t)\} / (a_t \cdot 7) + \{h_{o,s}^*(t) - h_{o,m}^*(t)\} / (a_s \cdot 7) \right\} \right] \quad (7.5)$$

So the total water supply rate is the sum of the water needed for sub-irrigation and that needed for the change in water volume in the surface water system.

Because $v_d(t+7)$ is not known, the best estimate is the flux which corresponds with $h_F^*(t)$ and $h_{o,t}^*(t+7)$. The latter is equal to $h_{o,m}^*(t)$ or, in case $v_{o,p}$ is limited by s'_m , it is calculated from eq. (7.5).

An alternative solution for the determination of $v_{o,p}(t)$ could have been the incorporation of a feedback between discharge over the weir, $v_{o,w}$, and $v_{o,p}$. E.g. $v_{o,p} = s_m$ as long as $v_{o,w} = 0$ and $v_{o,p} = 0$ when $v_{o,w} > 0$. In practice this would involve either frequent observation of the weirs and a frequent adjustment of the inlet structure or monitoring and remote control of weir and inlet structure. Furthermore no water is supplied when $v_{o,p} < v_1$, where v_1 is a pre-set small water supply rate.

The above operational rules are handled in a separate subroutine of SWAMP, called MANAGEMENT. To compare different ways of surface water management three options for water management have been incorporated in this subroutine, namely:

- weirs with a fixed crest height;
- adjustable weirs without water supply (water conservation);
- adjustable weirs with water supply.

For verification purposes a fourth option is added with the surface water level in the tertiary system as an input variable. Fig. 7.3 gives the flow chart of the subroutine MANAGEMENT.

7.2. ESTABLISHMENT OF OPERATIONAL RULES

In the operational rules discussed in the previous section various parameters are incorporated that have to be known beforehand. The determination of values for these parameters started with the definition of a soil physical - hydrological situation representative for the research area and will be referred to as reference. For this purpose the following choices were made:

- soil physical unit XI (improved iWp)
- $v_a = 0.0 \text{ mm} \cdot \text{d}^{-1}$ (no seepage)
- $T = 200$ days
- $\eta_f = 0.8$ (shape factor for phreatic surface)
- $c_d = 0.003$ (discharge coefficient for weirs (eq. 5.12))
- small canals in a good state of maintenance
- standard crop of potatoes for starch production

For this reference case three different situations of surface water management have been considered:

- a) weir with a fixed crest with a height equal to phase 0 (winter level). The average yearly transpiration for this zero situation is denoted as \overline{T}_O ($\text{mm}\cdot\text{a}^{-1}$);
- b) adjustable weir and no water supply, representative for water conservation. The average yearly transpiration is denoted as \overline{T}_C ($\text{mm}\cdot\text{a}^{-1}$);
- c) adjustable weir with conservation and water supply with a supply capacity of $1.5 \text{ mm}\cdot\text{d}^{-1}$. The average yearly transpiration and amount of water supply is denoted as \overline{T}_S and $\overline{v}_{O,p}$ respectively ($\text{mm}\cdot\text{a}^{-1}$).

The effect of conservation is defined as:

$$\overline{\Delta T}_C = \overline{T}_C - \overline{T}_O \quad (\text{mm}\cdot\text{a}^{-1}) \quad (7.6)$$

The water supply situation could have been compared with the zero situation, but because water supply implies conservation, its effect is compared with the conservation case, so:

$$\overline{\Delta T}_S = \overline{T}_S - \overline{T}_C \quad (\text{mm}\cdot\text{a}^{-1}) \quad (7.7)$$

Another indicator is the average supply efficiency defined as:

$$\overline{e}_w = (\overline{\Delta T}_S / \overline{v}_{O,p}) \cdot 100\% \quad (7.8)$$

For the above situations a number of different water management strategies were chosen. For each

strategy the hydrological consequences were simulated with SWAMP for the years 1971-1982, yielding average values for T_O , T_C and T_S . These values were corrected for waterlogging damage (see Section 8.7).

The results of the procedure are given in Table 7.4. In run 0 rises in open water level due to outflow and drops due to sub-irrigation in periods with low groundwater depths are accounted for. In run 1 an automatic weir that keeps the surface water level constant is introduced. The positive value of $\overline{\Delta T}_C$ is caused by reduced damages in spring. To maintain the level a supply of 80.9 mm in summer is necessary; its effect on transpiration is surprisingly high ($\overline{\Delta T}_S = 10.9 \text{ mm}\cdot\text{a}^{-1}$). In run 2 the target level is the same each year. From 15 March on the target level is raised with 0.10 m each week till the summer level is reached. From 15 August on the target level is lowered with 0.10 m each week till the winter level is reached again. Only when the groundwater depth becomes less than 0.60 m below soil surface, the summer level is lowered. In the introduction this type of water management has been called complaint system. It gives a rather high conservation effect: $\overline{\Delta T}_C = 10.0 \text{ mm}\cdot\text{a}^{-1}$. It requires a water supply of $96.0 \text{ mm}\cdot\text{a}^{-1}$ and causes an additional transpiration, $\overline{\Delta T}_S$, of $12.6 \text{ mm}\cdot\text{a}^{-1}$.

A water management strategy in which the surface water level depends on the actual conditions is that used by the waterboard 'De Veenmarken' (run 3). It has the following characteristics. Until $t_1 = 50$ a winter level of 1.40 m is applied. After t_1 the target

Table 7.4. Results of simulations with SWAMP to establish operational rules for the surface water management. The properties of the reference case used with these simulations are given in the text

Run nr.	Description	\overline{T}_O ($\text{mm}\cdot\text{a}^{-1}$)	$\overline{\Delta T}_C$ ($\text{mm}\cdot\text{a}^{-1}$)	$\overline{\Delta T}_S$ ($\text{mm}\cdot\text{a}^{-1}$)	$\overline{v}_{O,p}$ ($\text{mm}\cdot\text{a}^{-1}$)	\overline{e}_w (%)
0	weir with a fixed weir crest at 1.40 m below soil surface (zero situation)	258.3				
1	$h_{O,m}^*$ constant at 1.40 m below soil surface	258.3	2.4	10.9	80.9	13.4
2	$h_{O,m}^*$ in winter 1.40 m below soil surface, in summer 0.90 m below soil surface unless $h_f^* < 0.60$ m	258.3	10.0	12.1	96.0	12.6
3	waterboard strategy with small modification	258.3	14.9	10.4	110.5	9.3
4	as 3 + supply depending on $W_{R,d}$	258.3	14.9	8.4	93.3	9.0
5	as 3 + coupling between h_f^* and $h_{O,m}^*$ according to Table 7.7	258.3	14.1	9.4	92.3	10.2
6	as 5 + coupling between $W_{R,d}$ and $h_{O,m}^*$ according to Table 7.8	258.3	14.1	9.3	92.5	10.1
7	as 6, t_4 3 weeks earlier	258.3	14.4	9.1	70.8	12.8
8	as 6, t_4 6 weeks earlier	258.3	14.4	8.2	41.4	19.8
9	as 7, t_1 15 March	258.3	10.9	13.7	85.0	16.1
10	as 7, shift of 0.20 m in weir crest and phases ('wetter' management)	269.8	4.1	7.5	57.3	13.1
11	as 7, more restrictive demands for h_f^* to allow the different phases	258.3	8.4	12.7	83.3	15.2

Table 7.5. The relation between groundwater depth h_f^* and target level $h_{o,m}^*$ as applied by the waterboard 'De Veenmarken' and used in run 3 of Table 7.4

Groundwater depth (m below soil surface)	Phase	Target level (m below soil surface)	Remarks
>0.80	1	1.30	
>0.85	2	1.20	
>0.90	3	1.10	
>1.00	4	1.00	
>1.10	5	0.90	
>1.20	6	0.80	only permitted in July and August
>1.30	7	0.70	

Table 7.6. The dependency of t_4 on the water deficit in the root zone, $W_{r,d}$, as applied in run 3 for the determination of t_4

Water deficit in root zone (mm)	t_4 (day nr.)
$W_{r,d} < 10$	260 (15 September)
$10 < W_{r,d} < 30$	$305 - \{(30 - W_{r,d})/20\}(305-260)$
$W_{r,d} > 30$	305 (1 November)

level depends on groundwater depth. For modeling purposes the used relation is translated into figures given in Table 7.5. The time at which the change to winter level starts (t_4) depends on the wetness of the year. This vague rule is replaced by a relation between $W_{r,d}$ and t_4 as given in Table 7.6.

The consequences of this type of water management (run 3) are a significant improvement of $\overline{\Delta T_C}$, but a lower $\overline{\Delta T_S}$. The required amount of water ($110.5 \text{ mm} \cdot \text{a}^{-1}$) is high and its efficiency ($\overline{e_w}$) is lower.

In order to achieve a higher water supply efficiency the water supply rate has been made dependable on the water storage of the root zone as discussed in the former section. The results of run 4 show no significant improvement.

Especially when drainage resistances are low and/or the soil permeability of the transition zone is low, a groundwater depth of 1.20 m or more rarely will occur, because under those conditions sub-irrigation will exceed capillary rise. Therefore for run 5 Table 7.5 has been replaced by Table 7.7. Compared with run 4 there is a slight reduction in $\overline{\Delta T_C}$ and a slight increase in both $\overline{\Delta T_S}$ and $\overline{e_w}$.

In run 6 the effects of using a coupling between $W_{r,d}$ and target level (see Table 7.8) are shown. The differences with run 5 are negligible. For wetter conditions than modeled in the reference unit the appli-

Table 7.7. Demands for the groundwater depth, h_f^* , to allow different target levels, $h_{o,m}^*$, as used in run 5 of Table 7.4

Groundwater depth (m below soil surface)	Phase	Target level (m below soil surface)
0.85	1	1.30
0.90	2	1.20
0.95	3	1.10
1.00	4	1.00
1.05	5	0.90
1.05	6	0.80
1.05	7	0.70

Table 7.8. Coupling between water deficit in the root zone, $W_{r,d}$, and target level, $h_{o,m}^*$, used in run 7

Water deficit in root zone (mm)	Phase	Target level (m below soil surface)
<10	0-4	1.40, 1.30, 1.20, 1.10, 1.00
<20	5	0.90
>20	6,7	0.80, 0.70

cation of a table like Table 7.8 can be valuable.

Next the effects of a change in t_4 have been investigated (see run 7) by taking t_4 3 weeks earlier. This action definitely reduces the annual amount of water supply, $\overline{v_{o,p}}$, without a significant reduction in $\overline{\Delta T_S}$. Hence $\overline{e_w}$ increases from 10.1 to 12.8%.

The effects of taking t_4 6 weeks earlier are given under run 8. Compared with run 6 $\overline{\Delta T_S}$ is slightly reduced, but $\overline{v_{o,p}}$ is reduced far more, and $\overline{e_w}$ increases till 19.8%. Compared with run 7 $\overline{\Delta T_S}$ is reduced with $0.9 \text{ mm} \cdot \text{a}^{-1}$ and $\overline{v_{o,p}}$ with 39.6 mm . The marginal efficiency of water supply therefore is $(0.9/39.6) \cdot 100\% = 2.3\%$. Although this figure is very low, it can be calculated that the marginal costs of water supply are approximately Dfl 0.035 per m^3 and the marginal returns about Dfl 1.60 per m^3 (see Chapter 11). Hence water supply will be profitable if its marginal efficiency surpasses $(0.035/1.60) \cdot 100\% = 2.2\%$. For this reason the operational rules used in run 7 have been adopted in the further simulation runs.

In run 9 t_1 has been made 4 weeks later, i.e. 15 March. Compared with run 7 $\overline{\Delta T_C}$ reduces, but this is compensated by an increase of $\overline{\Delta T_S}$. The annual amount of water supply, however, increases from 70.8 to 85.0 mm. This strategy is only interesting when water supply is not limited.

A very important question is whether the chosen target levels are correct. In run 10 therefore the

target levels have been raised with 0.20 m. In this case the effects of conservation and water supply must be compared with the reference situation with a weir crest of 1.20 m. Compared with run 7 $\overline{\Delta T_C}$ decreases sharply because of a considerably higher value of $\overline{T_O}$. For the zero situation a fixed weir crest at 1.40 m below soil surface evidently is too low. Both $\overline{\Delta T_S}$ and $\overline{v_{O,p}}$ become less, so that $\overline{e_w}$ approximately remains the same.

The results of run 10 show that a higher water level now takes over the conservation effect which itself becomes very small. However, the sum of $\overline{T_O}$, $\overline{\Delta T_C}$ and $\overline{\Delta T_S}$ in run 10 remains nearly the same as in run 7 so that this wetter type of water management has not been accepted.

From the sensitivity analyses (Chapter 8) it follows that the results of the model are sensitive for changes in the parameters for waterlogging. Because a proper determination of these parameters is very difficult, a more restrictive type of water management may be better. Therefore in run 11 the different phases are only allowed at groundwater tables 0.20 m below those used in run 7. This change means that phase 1 only is allowed when the groundwater depth is more than 1.00 m below soil surface, etc. Compared with run 7, $\overline{\Delta T_C}$ now reduces from 14.4 to 8.4 $\text{mm}\cdot\text{a}^{-1}$, but $\overline{\Delta T_S}$ increases to 12.7 $\text{mm}\cdot\text{a}^{-1}$ and water supply efficiency becomes 15.2%. The decrease in $\overline{\Delta T_C}$ cannot be compensated fully by an increase in $\overline{\Delta T_S}$.

The above procedure, although less detailed, has been applied to soil physical units IV (iVz) and VIII (Hn21). For unit IV no significant differences were found. For unit VIII a significant improvement resulted from the wetter type of management of run 10 (a shift of 0.20 m in the target levels). Table 7.9 clearly illustrates this. The more favourable effects for this type of soil are due to its higher drought sensitivity.

The final result of the 'trial and error' method described above is that for all soil physical units, except unit VIII, for both conservation and water supply run 7 is chosen. For soil physical unit VII the

Table 7.10. Water balance of the unsaturated zone during the growing season (1 April - 1 October) and groundwater depth at 1 October for the water management corresponding to run 7 in Table 7.4 for the zero situation, for conservation and for water supply, averaged over the period 1971-1982

	Zero situation	Conservation	Water supply
$\overline{P_n}$ (mm)	302.6	302.6	302.6
$\overline{E_s}$ (mm)	57.2	57.2	57.2
$\overline{E_t}$ (mm)	258.2	272.2	281.4
$\overline{\Delta W_r}$ (mm)	2.1	-0.8	-0.1
$\overline{\Delta W_s}$ (mm)	-81.5	-68.3	-25.7
$\overline{v_b}$ (mm)	-66.6	-42.3	10.2
$\overline{h_f}$ at 1/10 (m)	1.57	1.47	1.25

'wetter' type of water management (run 10) is preferred. A review of the model approach and the operational rules applied for the simulation of effects of surface water management are described in the Appendix.

So far only the effects of conservation on the increase in average annual transpiration and the required amount of water have been discussed. To show the effects of water management on separate water balance terms and on groundwater depths in autumn Table 7.10 gives data for the unsaturated zone and Table 7.11 for the surface water system of the reference. Compared with the zero situation the lower boundary flux, $\overline{v_b}$, with conservation increases from -66.6 to -42.3 mm. This extra flux decreases the groundwater depth, giving a higher transpiration. With water supply, $\overline{v_b}$ even becomes positive, resulting in a considerably wetter situation and an increase in transpiration from 272.2 to 281.4 mm. The groundwater depth in autumn (1 October) rises from 1.57 m in the zero situation to 1.47 m in the case of conservation and to 1.25 m with water supply.

The water balance of the surface water system is given in Table 7.11. Because no storage is considered in the saturated zone, the inflow into the canals, v_d , numerically equals v_d in Table 7.10, though with opposite sign. The differences between zero situation and conservation are mainly caused by the differences in this drainage flux, $\overline{v_d}$. A lower value of $\overline{v_d}$ for

Run nr.	Description	$\overline{T_O}$ ($\text{mm}\cdot\text{a}^{-1}$)	$\overline{T_C}$ ($\text{mm}\cdot\text{a}^{-1}$)	$\overline{T_S}$ ($\text{mm}\cdot\text{a}^{-1}$)	$\overline{v_{O,p}}$ ($\text{mm}\cdot\text{a}^{-1}$)	$\overline{e_w}$ (%)
1	phase 0 is 1.40 m below soil surface, etc.	197.7	20.7	13.2	46.2	28.6
2	phase 0 is 1.20 m below soil surface, etc.	214.5	8.5	16.4	53.7	30.5

Table 7.9. Influence of a shift in target levels of 0.20 m on effects of conservation and water supply of soil physical unit VIII (Hn21)

Table 7.11. Water balance of the surface water system during the growing season (1 April - 1 October) for the management corresponding to run 7 in Table 7.4 for the zero situation, for conservation and for water supply, averaged over the period 1971-1982

	Zero situation	Conservation	Water supply
$\overline{\Delta h_{o,t} \cdot a_t}$ (mm)	-10.9	-14.4	-8.5
$\overline{\Delta h_{o,s} \cdot a_s}$ (mm)	-1.2	-1.8	-1.1
$\overline{v_d}$ (mm)	66.6	42.3	-10.2
$\overline{v_{o,w}}$ (mm)	-78.7	-58.5	-72.6
$\overline{v_{o,p}}$ (mm)	-	-	73.2

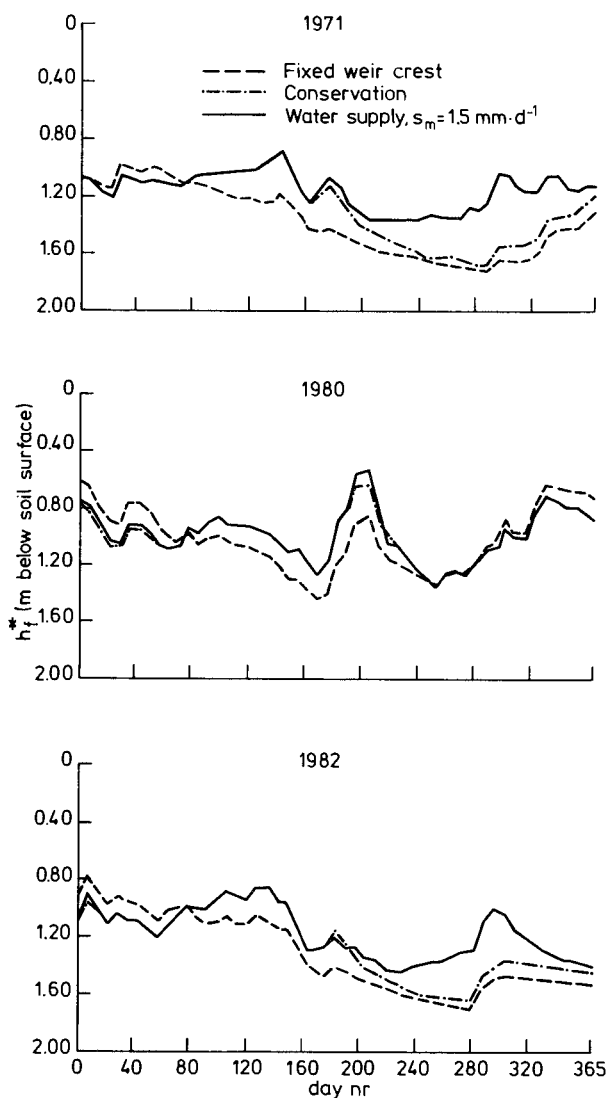

Fig. 7.4. Effect of different water management systems on the depth of the groundwater during 1971 (rather dry growing season), 1980 (wet growing season) and 1982 (dry growing season)

conservation results in a lower discharge over the weir, $\overline{v_{o,w}}$. With water supply the supplied water, $\overline{v_{o,p}}$, of 73.2 mm is used for a decrease in $\overline{v_d}$ of 52.5 mm, resulting in a negative value (inflow into the

soil) over the balance period. Further the flux over the weir increases with 14.1 mm, while surface water storage takes the remaining 6.6 mm.

The effect of surface water management on the depth of the groundwater is illustrated in Fig. 7.4, in which for three years simulated depths of the groundwater for the reference, for conservation and for water supply are depicted.

From the simulation results discussed above a number of conclusions can be drawn:

- the system is rather inert. Consequently the potential for improving the effects of conservation and water supply by refining rules is limited;
- there is no guarantee that the operational rules obtained by the 'trial and error' procedure cannot be improved further;
- the resulting operational rules are easy to understand and easy to apply in practice. The manager can adapt these rules to his own specific circumstances;
- although the efficiency of water supply is low, it will be shown in Chapter 11 that nevertheless it can be economically justified to bring water to the region.

7.3. COMPARISON OF 'MODEL' SURFACE WATER MANAGEMENT AND THE MANAGEMENT PERFORMED BY THE WATERBOARD 'DE VEENMARKEN'

The final result of improving the operational rules was a refinement of the surface water management applied by the waterboard 'De Veenmarken'. Hence the 'model' water management should also produce better results in other periods than those used for the determination of the rules.

The year 1983 offered an opportunity for a check. It was an exceptional year; a very wet period from 15 March until the end of May was followed by an extremely dry period from June until August. Especially May was very wet. To investigate whether the surface water management according to the model is satisfactory under such circumstances, the year 1983 has been simulated. The effects of the proposed management have been compared with the actual management performed by the waterboard 'De Veenmarken'. A detailed report is given by Van BAKEL (1984). In the following only the most important results are given.

In Fig. 7.5 the actual course of the surface water level is compared with the model results for conservation and for supply with a capacity of 2.5 mm·d⁻¹.

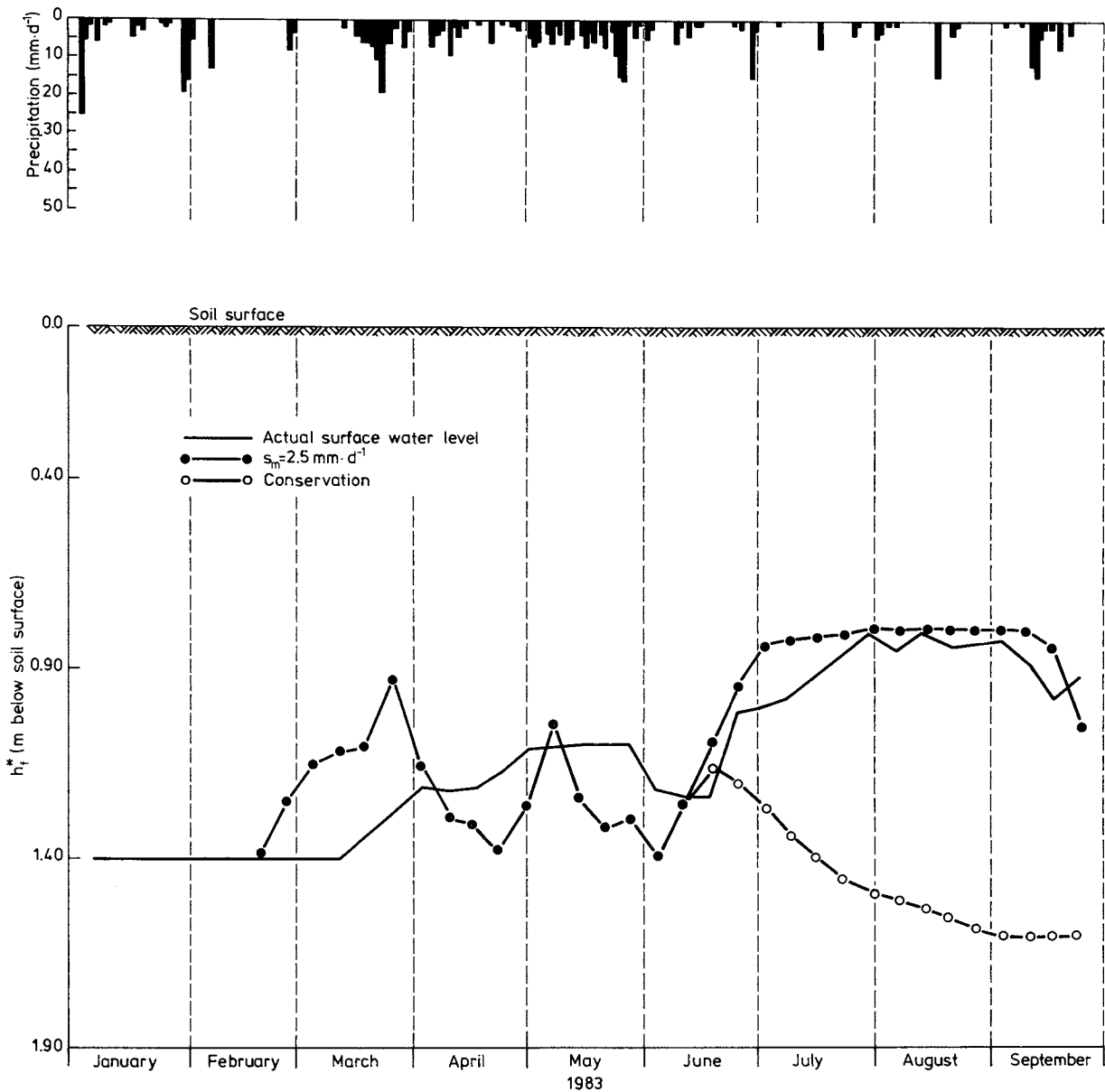

Fig. 7.5. Comparison of observed and simulated courses in time of the surface water level during the first nine months of 1983

The 'model' operator starts nearly a month earlier in spring to raise the surface water level. In periods of a high precipitation surplus (e.g. March, May) he lowers the surface water level faster than practice does. One should, however, take in mind that in practice high water levels in canals further downstreams restricted the required lowering of the weirs, particularly in May. In the dry period from June till August the actual water supply capacity was below the capacity assumed in the model, resulting in a somewhat lower actual surface water level.

Using the actual supply capacity during the latter period as input, the 'model' management gives an increase in transpiration for the standard potato

crop of 59.2 and 38.2 mm on soil physical units XI and VI, respectively, while for the waterboard management these data are 54.5 and 30.7 mm. The model management therefore gives an improvement of 10 to 25%. It must be noted, however, that part of this improvement may be due to the too high surface water levels actually occurring during the wet period in May.

8. SENSITIVITY ANALYSIS OF SWAMP

8.1. INTRODUCTION

In this chapter the sensitivity analysis of SWAMP is dealt with. In this analysis single parameters or complexes of parameters have been changed to find their effect on the final results, i.e. the increase in average annual transpiration caused by conservation, $\overline{\Delta T_C}$, by water supply with a maximum supply capacity of $1.5 \text{ mm}\cdot\text{d}^{-1}$, $\overline{\Delta T_{1.5}}$, and the average annual efficiency of water supply, $\overline{e_w}$. The soil physical - hydrological unit described in Section 7.2, has been chosen as a reference together with one standard crop (potatoes for starch production). For the surface water management the operational rules given for run 7 of Table 7.4 were used.

The sensitivity of soil physical properties, drainage resistance, maintenance of small canals, dimensions of weirs, magnitude of regional flux and parameters for waterlogging damage have been investigated.

8.2. SOIL PHYSICAL PROPERTIES

For the calculation of the effects of surface water management strategies in the whole region 'De Monden' that will be discussed in the next chapter, one soil physical unit was assigned to each section. As explained in Chapter 3 this assignment was based on the soil map 1:50 000 and an inventory of soil-im-

Table 8.1. Influence of soil physical unit on transpiration, $\overline{T_O}$, on conservation effect, $\overline{\Delta T_C}$, on water supply effect, $\overline{\Delta T_S}$, and on efficiency of water supply, $\overline{e_w}$, simulated with SWAMP and averaged over the period 1971-1982

	Soil physical unit				
	XI (reference (improved peat)	VIII (Hn21) (sand)	VII (iWp) (peaty)	I (zVc) (deep peat)	IV (iVz) (mod. deep peat)
$\overline{T_O}$ ($\text{mm}\cdot\text{a}^{-1}$)	258.3	214.5	229.1	242.7	248.2
$\overline{\Delta T_C}$ ($\text{mm}\cdot\text{a}^{-1}$)	14.1	8.5	17.6	8.2	5.1
$\overline{\Delta T_S}$ ($\text{mm}\cdot\text{a}^{-1}$)	9.4	15.8	9.6	7.9	8.3
$\overline{e_w}$ (%)	13.3	29.4	16.6	10.9	16.3

proved parcels. Here the sensitivity of the model for the choice of the soil physical unit will be treated. This has been done by replacing the soil physical unit used in the reference by a number of other units.

Table 8.1 gives the results of this replacement. The values of $\overline{T_O}$ obtained for the case of a fixed weir have been given to indicate the differences in water delivery capacity of the various soil physical units. The considerably lower value of $\overline{T_O}$ for unit VIII causes a higher profit of water supply compared with the reference, so that $\overline{\Delta T_S}$ increases from 9.4 to $15.8 \text{ mm}\cdot\text{a}^{-1}$. To reach this effect a lower amount of water is needed, resulting in a high efficiency of water supply (29.4%). Soil physical unit VII has also a low $\overline{T_O}$, but $\overline{\Delta T_S}$ and $\overline{e_w}$ are lower than unit VIII. On the other hand, $\overline{\Delta T_C}$ is higher compared with the reference. Soil physical unit I shows rather low values of $\overline{\Delta T_C}$, $\overline{\Delta T_S}$ and $\overline{e_w}$. This is probably caused by underestimating the hydraulic properties of the peat layers in the subsoil, as was already discussed in Chapter 6. Soil physical unit IV has also a relatively thick peat layer, resulting in a low value of $\overline{\Delta T_S}$, but the efficiency of water supply is comparable with that of the reference. For the low value of $\overline{\Delta T_C}$ no explanation can be found.

The results of the sensitivity analysis show that the choice of the soil physical unit is important for the final result. Therefore it is not allowed to take one unit for the whole region and the distinction between deep peat soils, moderate deep peat soils, peaty soils, improved peaty soils and sandy soils has to be maintained.

8.3. DRAINAGE RESISTANCE

In the sensitivity analysis of FEMSATS (Table 6.1) it already turned out that the influence of the drainage resistance, T, on heights of the phreatic surface was considerable. The simulation results of SWAMP for different T-values are presented in Table 8.2. The conservation effect, $\overline{\Delta T_C}$, is decreased when T is increased to 300 days whereas decreasing T has little influence.

The effect of water supply, $\overline{\Delta T_S}$, clearly depends

Table 8.2. Influence of the drainage resistance on transpiration, \bar{T}_O , on water conservation effect, $\Delta\bar{T}_C$, on water supply effect, $\Delta\bar{T}_S$, and on efficiency of water supply, \bar{e}_w , simulated with SWAMP and averaged over the period 1971-1982

	Drainage resistance			
	$\bar{T} =$ 200 d (reference)	$\bar{T} =$ 50 d	$\bar{T} =$ 100 d	$\bar{T} =$ 300 d
\bar{T}_O (mm·a ⁻¹)	258.3	254.0	257.5	262.5
$\Delta\bar{T}_C$ (mm·a ⁻¹)	14.1	13.5	12.9	8.9
$\Delta\bar{T}_S$ (mm·a ⁻¹)	9.4	15.7	-	8.1
\bar{e}_w (%)	13.3	19.7	-	10.8

on the drainage resistance because it increases with 70% if \bar{T} reduces from 200 days to 50 days. Such a low value of \bar{T} might be achieved by pipe drainage at a mutual distance of about 15 m, used for drainage in winter and for sub-irrigation in dry summer periods. In Chapter 10 special attention will be paid to the consequences of using pipe drainage.

8.4. MAINTENANCE OF TERTIARY SYSTEM

Maintenance conditions of the tertiary system ('wijken') influences its hydraulic properties. To reckon with these conditions in SWAMP, the following parameters may be changed:

- the coefficient C_t in eqs. (5.16) and (5.17). For the reference the tertiary system is assumed to be in a good state of maintenance, having a value $C_t = 0.10 \text{ d}^{-1} \cdot \text{m}^{-1}$;
- the bottom depth, $h_{O,C}^*$. For the reference $h_{O,C}^*$ is taken 1.60 m below soil surface.

Field data showed that in a watercourse moderately overgrown with weeds, C_t decreased by a factor 5, while $h_{O,C}^*$ was only about 1.00 m. In watercourses heavily overgrown with water weeds C_t decreased with a factor 10 and $h_{O,C}^*$ was 0.90 m.

In Table 8.3 the simulated results of these two situations are compared with those of the reference. For a moderately overgrown watercourse \bar{T}_O is higher than in the reference situation. This is caused by a smaller depth of the bottom of the watercourse, $h_{O,C}^*$, giving higher surface water levels. In this way conservation already occurs in the zero situation and the effect of conservation by means of automatic weirs, i.e. $\Delta\bar{T}_C$, even becomes negative. For the same reason the effect of water supply is strongly reduced.

Table 8.3. Influence of maintenance of the tertiary system on yearly transpiration, \bar{T}_O , on water conservation effect, $\Delta\bar{T}_C$, and on water supply effect, $\Delta\bar{T}_S$, simulated with SWAMP and averaged over the period 1971-1982

	Cleaned (reference)	Moderately overgrown	Heavily overgrown
\bar{T}_O (mm·a ⁻¹)	258.3	275.0	245.6
$\Delta\bar{T}_C$ (mm·a ⁻¹)	14.1	-2.0	0.0
$\Delta\bar{T}_S$ (mm·a ⁻¹)	9.4	4.0	0.0

Heavily overgrown watercourses will lead to waterlogging. Because the bottom of the watercourse, $h_{O,C}^*$, is at 0.90 m below soil surface, no water can enter these watercourses unless phases 6 or 7 are applied. Under wet circumstances such high surface water levels are never allowed, and will certainly damage the crop. This results in 'no effect' response of the model on conservation and water supply.

The results clearly show that maintenance conditions of the tertiary system are important to prevent waterlogging. Poor maintenance will nullify the beneficial effects of conservation and water supply.

8.5. DIMENSIONS OF WEIR

In SWAMP the weir is modeled as a stage - discharge relationship in the form (see eq. 5.12):

$$v_{O,W} = c_d (h_w^* - h_{O,W}^*)^n \quad (8.1)$$

where c_d is discharge coefficient and n is exponent. The numerical value of c_d has been derived from eq. (5.14):

$$c_d = C_d' \times a_w \times 8640 \quad (8.2)$$

where a_w is specific width of weir expressed in $\text{m} \cdot \text{ha}^{-1}$. A value for a_w of 0.003 means that one meter of weir width is available for each 333 ha. In general, this design criterium is used for hand-operated weirs; an automatic weir can be considerably narrower.

To investigate the effects of dimensions of weirs, a_w has been changed in respectively 0.002 and 0.001 $\text{m} \cdot \text{ha}^{-1}$, corresponding with 1 m weir per 500 and 1000 ha respectively. Table 8.4 gives the results. The outcome is that the dimension of the weir has very little influence. Hence, it may be concluded that the design criterium of 1 m weir per 333 ha for hand-operated weirs can be reduced to 1 m weir per 1000 ha for automatic weirs.

Table 8.4. Influence of dimensions of weir on conservation effect, $\overline{\Delta T_C}$, on water supply effect, $\overline{\Delta T_S}$, and on efficiency of water supply, e_w , simulated with SWAMP and averaged over the period 1971-1982

	$a_w =$ 0.003 m·ha ⁻¹ (reference)	$a_w =$ 0.002 m·ha ⁻¹	$a_w =$ 0.001 m·ha ⁻¹
$\overline{\Delta T_C}$ (mm·a ⁻¹)	14.1	15.8	14.0
$\overline{\Delta T_S}$ (mm·a ⁻¹)	9.4	8.5	9.6
e_w (%)	13.3	11.6	13.2

8.6. MAGNITUDE OF REGIONAL FLUX

In Chapter 5 the influence of the regional seepage flux has been discussed. The regional flux (averaged over a section) was expressed as a $v_a = f(\overline{h_f^*}, h_0^*)$ -relationship and is used as part of the lower boundary condition of the unsaturated system: $v_b = v_d + v_a$. In Chapter 6 the possible maximum systematic error in v_a has been estimated at 0.24 mm·d⁻¹. About twice this value will be used to investigate the sensitivity of SWAMP for the magnitude of the regional (seepage) flux.

For the reference situation v_a has been taken zero. This situation has been compared with situations where $v_a = -0.5$ and 0.5 mm·d⁻¹. The results for $\overline{\Delta T_C}$ and $\overline{\Delta T_S}$ are given in Fig. 8.1.

The conservation effect is the highest with $v_a = 0$. The lower value of $\overline{\Delta T_C}$ with $v_a = 0.5$ mm·d⁻¹ can be explained by the fact that the seepage already causes an increase in transpiration without water management. The lower value of $\overline{\Delta T_C}$ with $v_a = -0.5$ mm·d⁻¹ is a result of the extra loss of water by downward seepage after the surface water level has been raised in

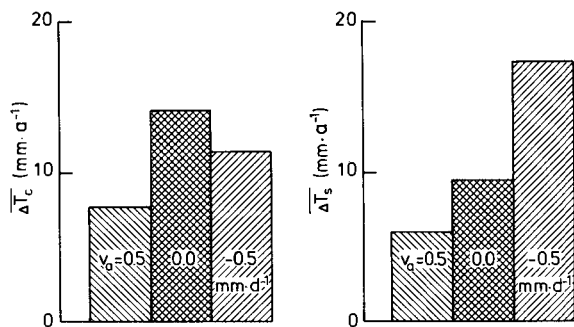

Fig. 8.1. Influence of magnitude of regional flux on water conservation effect, $\overline{\Delta T_C}$, and on water supply effect, $\overline{\Delta T_S}$, simulated with SWAMP and averaged over the period 1971-1982

spring.

The effect of water supply increases from upward seepage (0.5 mm·d⁻¹) to downward seepage (-0.5 mm·d⁻¹), because the drought effects increase.

The results show that differences in magnitude of regional flux are important. A good knowledge of the regional pattern of seepage is necessary to estimate the effects of surface water management.

8.7. WATERLOGGING DAMAGE

One of the reasons to have low groundwater tables, especially in spring is to prevent damage due to waterlogging. Wet soil conditions cause poor workability and favour unwanted soil compaction. In SWAMP these circumstances are taken into account by setting as a condition that for tillage in spring the soil water pressure in sandy and reclaimed cut-over peat soils at 5 cm below surface should be below -0.70 m to prevent compaction (BOELS et al., 1980; BOELS and HAVINGA, 1980; BEUJING, 1982). On the average 10 'workable' days are required in the period between 20 March and 10 April for sowing sugar beets and planting potatoes (BEUJING, 1982). For harvesting the same author gives a required soil water pressure head below -0.60 m. For wheat no criteria are necessary because during harvest of this crop (July-August) wet soil conditions generally will not occur.

In SWAMP a possible delay in sowing or planting time shifts the time scale in the standard growth curves (see Fig. 4.2) influencing crop cover and crop height and hence transpiration.

For the purpose of modeling in spring a workable day is defined as a day at which the groundwater table is below 0.70 m, a non-workable day as a day with a water table above 0.70 m. In autumn a workable day is defined as a day at which the groundwater table is below 1.00 m, a non-workable day as a day with a water table above 0.60 m. Days at which the water table is between 0.60 and 1.00 m are partly workable; the non-workable part n_w is taken into account according to:

$$n_w = 1 - (100 - h_f^*)/40 \quad (8.3)$$

Sowing or planting is considered to be finished as soon as a total of 10 workable days have passed after 20 March. For harvest it is assumed that a farmer needs at least 30 workable days in the period 15 September - 1 November. If the simulated number of workable days is less than 30, harvesting is assumed to start earlier and the consequences with respect to

transpiration are taken into account by ending the standard crop curves accordingly.

A possible reduction in transpiration due to too wet soil conditions during the growing season is taken into account by the parameters a_1 and a_2 in the relation between relative soil water storage and transpiration (see Fig. 5.5): a_1 is the anaerobiosis point and a_2 is a particular water storage above which reduction in transpiration due to waterlogging occurs. In SWAMP the value for a_1 is taken 0.90 as an estimation because little is known about its actual value.

According to WIEBING (1983, pers. comm., Institute for Land and Water Management Research (ICW), Wageningen) potatoes need a minimum air content, $\theta_a = 0.12$, in the root zone for an undisturbed root metabolism. Taking for the saturated water content $\theta_s = 0.60$ (Table 4.2), a_2 then becomes 0.80. However, the figures in Table 4.2 stem from samples which have been taken before ploughing took place. Especially for potatoes farmers try to create a loose root zone and therefore $a_2 = 0.85$ is chosen as a good approximation.

The sensitivity of the model results for the parameters a_1 and a_2 has been investigated by changing them from 0.90 and 0.85 to 0.85 and 0.80 respectively. By this change the effect of conservation, $\overline{\Delta T_c}$, decreased dramatically from $14.1 \text{ mm}\cdot\text{a}^{-1}$ for the reference unit to $0.2 \text{ mm}\cdot\text{a}^{-1}$ while $\overline{\Delta T_s}$ only slightly decreased from 9.4 to $8.4 \text{ mm}\cdot\text{a}^{-1}$. Because of the high sensitivity of the model for these parameters extra attention is paid to them.

SWATRE has more possibilities to investigate the sensitivity of the parameters for waterlogging damage, because of its different options for water uptake by roots and its more detailed modeling of the flow processes in the unsaturated zone. In SWATRE two options for the modeling of water uptake by roots are possible (BELMANS et al., 1983):

- a) maximum possible root water uptake, S_{\max} , is a function of $E_{t,p}$ defined as:

$$S_{\max} = E_{t,p}/z_r \quad (8.4)$$

where z_r is rooting depth

and the actual uptake is a function of the soil water pressure head, h_p , according to:

$$S(h_p) = \alpha_S(h_p) S_{\max} \quad (8.5)$$

where $\alpha_S(h_p)$ is a prescribed function determined by the pressure head values p_1 through p_4 (Fig. 8.2);

- b) maximum possible root water uptake is independent

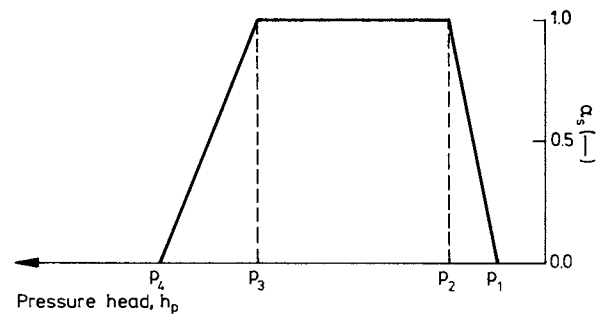

Fig. 8.2. Relation between dimensionless sink term variable, α_S , and soil water pressure head, h_p (after Belmans et al., 1983)

of $E_{t,p}$, but is defined by the root system (HOOGLAND et al., 1981), in the manner

$$S_{\max} = a + b|z| \quad (8.6)$$

where a and b are constants to be determined from measured root water uptake data. Because in the study no detailed information about root water uptake was available, for a and b the values of 0.02 and 0.0, as advised by BELMANS et al. (1983), have been adopted.

Method b) gives the best option for investigating the sensitivity of the model for changes in the waterlogging parameters p_1 and p_2 , but it requires the thickness of the root zone in the course of time. According to WIEBING (1983, pers. comm.) the root development of potatoes is $0.66 \text{ cm}\cdot\text{d}^{-1}$, starting at planting time and continuing until the roots reach their maximum depth about mid-July. The very wet growing season of 1980 has been taken, because in the period 1971-1982 only this year did show a reduction in transpiration due to too wet conditions.

In Table 8.5 the results of simulations with different values for p_1 and p_2 and different alternatives of surface water management are given. In run 1 the most likely values for p_1 and p_2 have been used. In this wet year application of conservation leads to a considerable decrease in transpiration, i.e. 59.1 mm. In run 2 the value of p_1 has been changed from -0.60 to -0.40 m. The effect of this change is that the profile may become wetter before root water uptake ceases completely. The effect on ΔT_c indeed is considerable, i.e. from -59.4 to -34.1 mm. In run 3, p_2 has been changed from -0.80 to -0.60 m compared with run 2. Now the reduction in transpiration due to water conservation is reduced from 34.1 to 25.8 mm. In run 4, p_1 has been changed from -0.40 to -0.50 m, resulting in an increased damage by water conservation. Now ΔT_c goes from -25.8 to -42.9 mm. The results

Table 8.5. Influence of changes in the parameters for root water uptake p_1 and p_2 (see Fig. 8.2) on the transpiration of potatoes in the zero situation, T_0 , and with conservation, T_c , simulated with the SWATRE-model for the wet year 1980 ($E_{t,p} = 237.0$ mm)

Run nr.	Description	P_1 (m)	P_2 (m)	Transpiration		Conservation effect, ΔT_c (mm)
				T_0 (mm)	T_c (mm)	
1	normal operation	-.60	-.80	211.8	152.7	-59.1
2	normal operation	-.40	-.80	213.0	178.9	-34.1
3	normal operation	-.40	-.60	213.3	187.5	-25.8
4	normal operation	-.50	-.60	213.3	170.4	-42.9
5	restrictive operation	-.40	-.80	213.0	210.1	- 2.9

of runs 1 to 4 prove that the sensitivity for parameters for waterlogging damage is very high. In run 5 a more restrictive surface water management has been applied. Instead of using the relationship between groundwater depth and surface water level of the standard operational rules (Table 7.7) the changes to higher phases were only allowed at groundwater tables 0.20 m lower than in the standard rules (compare run 11 in Table 7.4). So the target level was only raised when h_f^* became more than 1.00 m below soil surface.

The consequences of this restrictive surface water management in this particular year are very significant. The reduction in transpiration due to conservation sharply reduced from 34.1 for run 2 (with the same values for p_1 and p_2) to 2.9 mm. This result suggests that it may be better to apply restrictive management rules as long as there is no good determination of the parameters for waterlogging damage. On the other hand, it was only the year 1980 that showed a reduction in transpiration due to waterlogging. The crop yields in 1980, which were about 10% lower than the average over 1971-1982, give the impression that SWATRE overestimates this kind of damage. This could be due to the fact that potatoes are grown in ridges, whereas SWATRE assumes a flat soil surface.

According to the results of run 11 in Chapter 7, a more restrictive surface water management reduces the effect of conservation with 40% while the effect of water supply increases with 40%. Hence, if water supply is possible the decrease in $\overline{\Delta T_c}$ can be compensated by an increase of $\overline{\Delta T_s}$. This fact may have as a practical consequence that surface water management can be more restrictive if the water supply possibilities from outside the region are better.

The uncertainties concerning the effects of waterlogging have led to a dual approach in the establishment of the economical feasibility of surface water management: 'normal' versus 'restrictive'.

8.8. CONCLUSIONS

The results of the sensitivity of SWAMP for soil physical unit, drainage resistance, maintenance of watercourses, dimension of weirs, magnitude of regional flux and parameters for waterlogging damage give a good review of the importance of the different parameters and relationships. They can be summarized as follows:

- the influence of soil physical unit on the transpiration is high. Differences in soil physical properties therefore have to be taken into account;
- the effect of drainage resistance on water conservation is moderate, but is compensated by a larger effect of water supply. Differences in drainage resistance per section have to be taken into account;
- the maintenance of the watercourses is of great influence on both the transpiration in the zero situation and on the effects of water conservation and water supply. This is mainly due to the fact that poor maintenance causes higher water levels than in the zero situation and does not allow adequate water supply;
- the sensitivity for dimension of weirs is very low and can be neglected;
- the magnitude of the regional flux is of considerable importance, hence the regional pattern of seepage flux has to be known if one wants to calculate the effects of surface water management with a one-dimensional model like SWAMP;
- from the sensitivity analysis of the parameters for waterlogging damage during the growing season it may be concluded that waterlogging effects may be important. Until more is known about these effects, for the time being a more restrictive surface water management has to be considered too, especially when water supply from outside the area is possible.

9. EFFECTS OF SURFACE WATER MANAGEMENT FOR THE ENTIRE AREA 'DE MONDEN'

9.1. INTRODUCTION

With the models FEMSATS and SWAMP and the optimized operational rules the hydrological effects of different ways of surface water management are determined for the entire research area 'De Monden'. These results are next used to arrive at the production functions.

For weather conditions data of the meteorological station Eelde during the period 1971-1982 were used and for crops a standard potato crop for starch production was chosen (Section 9.2).

For each section given in Fig. 3.8 the regional groundwater flux $v_a = f(\bar{h}_f^*, h_o^*)$ was calculated with FEMSATS and used as the seepage flux at the lower boundary of the unsaturated system in SWAMP (Section 9.3). To each section representative hydrological and soil physical properties were assigned, after which the following water management strategies were simulated with SWAMP (see Appendix):

- I. weir with a fixed crest. The weir crest level is equal to the winter level of adjustable weirs (zero situation);
- II. conservation. The target level is determined from the operational rules derived in Chapter 7 (run 7 and run 10, respectively, depending on soil physical unit);
- III. water supply with a maximum supply capacity, s_m , of $0.75 \text{ mm}\cdot\text{d}^{-1}$;
- IV. water supply with $s_m = 1.50 \text{ mm}\cdot\text{d}^{-1}$;
- V. water supply with $s_m = 2.50 \text{ mm}\cdot\text{d}^{-1}$.

The gross effect of conservation is the difference in transpiration between conservation and the zero situation; the effects of water supply are the differences between the effects of the water management strategies III to V and conservation (Section 9.4).

The gross effects have to be corrected for the limited number of meteorological years used in simulations, the cropping pattern, the gross-net production, the unevenness of the soil surface, the shape of the phreatic surface and the expected changes in soil physical properties in the near future. The different corrections will be dealt with in Section 9.5. The net effects of the different water management strategies per section are totalled to obtain the net effects for the entire research area. These

final results will be treated in Section 9.6.

9.2. METEOROLOGICAL AND CROP DATA

Instead of using a limited number of typical hydrological years (e.g. wet, normal and dry), a historical record of meteorological data has been used here. Although this choice implies simulation over longer periods it was preferred for the following reasons:

- surface water management has an influence on damages caused by waterlogging and by water shortage. The choice of typical years therefore should have been based on both degree of water shortage and degree of waterlogging. Especially the latter is very difficult because there are three periods (spring, growing season, autumn) with different sensitivity for waterlogging damage. Moreover the conditions in a year typical for a selected water shortage will most probably not allow to simulate waterlogging problems successfully;
- the costs of running a simulation program like SWAMP on a computer are small and still will diminish in the near future.

Using a time series of meteorological records the number of years has to be decided. Generally a time span of at least 30 years is considered necessary to obtain a reliable representation of the climatological conditions. Such a long record for the neighbourhood of the area was not available. Therefore a historical record of 12 years (1971-1982) of the nearest meteorological station at Eelde (approximately 40 km north-west of the research area) has been chosen. Afterwards a correction for a longer time period has been applied, as will be explained in Section 9.5.

As a representative crop, potatoes for starch production has been chosen. This crop covers about 50% of the area. The remainder crops are sugar beets (30%) and cereals (20%). The effects of surface water management on the latter two crops will certainly not be the same as for a potato crop. Corrections needed in this respect will be discussed in Section 9.5.

9.3. SEEPAGE FLUXES PER SECTION

With FEMSATS the relationships $v_a = f(\bar{h}_f^*, h_o^*)$ per section were derived for fluxes across the phreatic surface, v_f , of 2.0, 1.0, 0.0, -1.0, -1.5, -2.0, -2.5, -3.0, -3.5, -4.0, -4.5, -5.0 and -5.5 $\text{mm}\cdot\text{d}^{-1}$, and surface water levels, h_o^* , equal to winter level, winter level -0.10, winter level -0.20, winter level -0.30, winter level -0.40 and winter level -0.50 m (= summer level). The values of both v_f and h_o^* were kept the same throughout the area in each run and every combination of the above mentioned values was simulated.

The choice of the outer boundary conditions has been based on the fact that the research area is 1) part of the whole region of the waterboard 'De Veenmarken', 2) part of the cut-over peat area and 3) the western border is formed by the Hondsrug.

If surface water management will be applied in 'De Monden', it will also be applied in the whole region of the waterboard 'De Veenmarken'. This means that the flows across the northern and the southern boundary of the research area will appr. remain the same. For the area east of 'De Monden' another waterboard intends to apply the same system of surface water management, hence also the flow across the eastern boundary will not change. West of the research area surface water management is not possible because of the high elevation of that area. Assuming that the flow across the western boundary remains constant would ignore the influence of changes in groundwater height in the research area, caused by the surface water management. Assuming a constant hydraulic head along the western boundary would ignore the changes in hydraulic head outside the area, caused by fluctuations inside. The best way to find proper boundary conditions would be to construct a groundwater flow model covering the research area and its surrounding.

Lack of geohydrological data and especially lack of knowledge of the spatial pattern of drainage resistance made this impossible. Analysis of the groundwater flow showed, however, that surface water management induced only limited changes in hydraulic head west of the research area. Therefore it was assumed that a constant head along the western boundary of the research area is the most realistic choice.

A total of 13 x 6 simulation runs with FEMSATS were performed.

The bottom of the watercourses was set at 1.60 m below surface. In case h_o^* in a particular nodal point of the FEMSATS grid system became deeper than 1.60 m, it was set equal to 1.60 m below soil surface and the drainage resistance was raised to a value of 100 000 days. In this way conditions with watercourses running dry could be handled with the same calculation procedure.

Surface runoff was accounted for by decreasing the drainage resistance, in case h_f^* becomes less than 0.20 m below soil surface, linearly from its original value at 0.20 m to 10 days for $h_f^* = 0.0$ m below soil surface. By applying this rule some sections started sooner with surface runoff than others. As a consequence h_f^* was influenced which in turn caused a rapid change in the regional groundwater flow pattern.

Some results of the computations are depicted in Figs. 9.1 through 9.7. Only the results for h_o^* equal to winter level and h_o^* equal to summer level are given. In most of the figures the relation between v_a and \bar{h}_f^* is approximately linear. Deviations at low \bar{h}_f^* -values reflect the influence of surface runoff in some sections, but these deviations play a minor role in the v_a -relationships. Most sections show positive values for v_a , indicating groundwater influx from elsewhere. Negative values, indicating outflow to other sections are limited to a few cases and their magnitudes rarely exceed $0.5 \text{ mm}\cdot\text{d}^{-1}$.

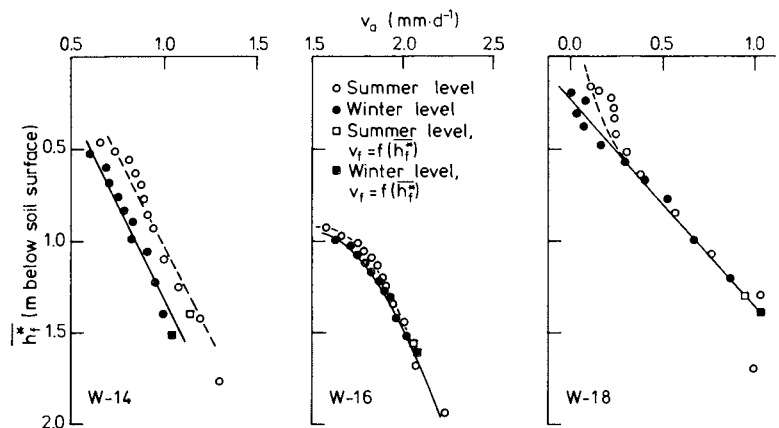

Fig. 9.1. The relationship $v_a = f(\bar{h}_f^*, h_o^*)$ of sections W-14, W-16 and W-18, calculated with FEMSATS, type A

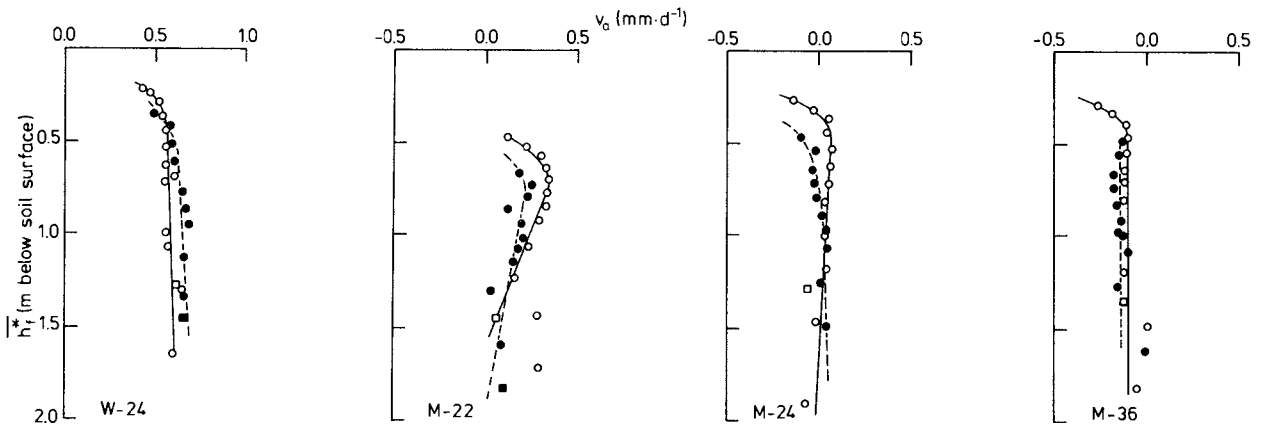

Fig. 9.2. The relationship $v_a = f(\overline{h_f^*}, h_o^*)$ of sections W-24, M-22, M-24 and M-36, calculated with FEMSATS, type B

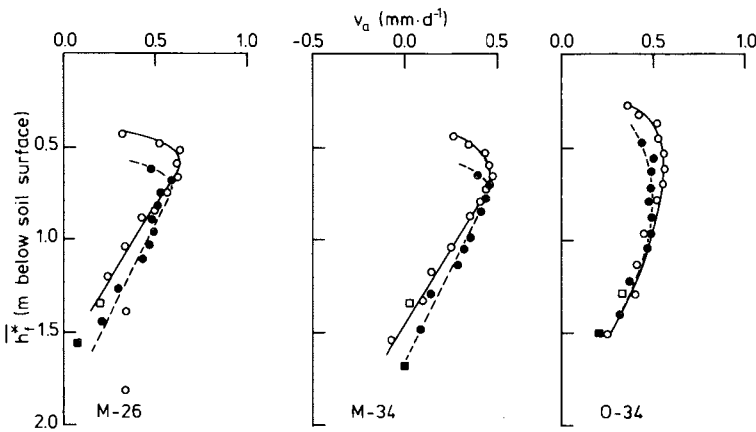

Fig. 9.3. The relationship $v_a = f(\overline{h_f^*}, h_o^*)$ of sections M-26, M-34 and O-34, calculated with FEMSATS, type C

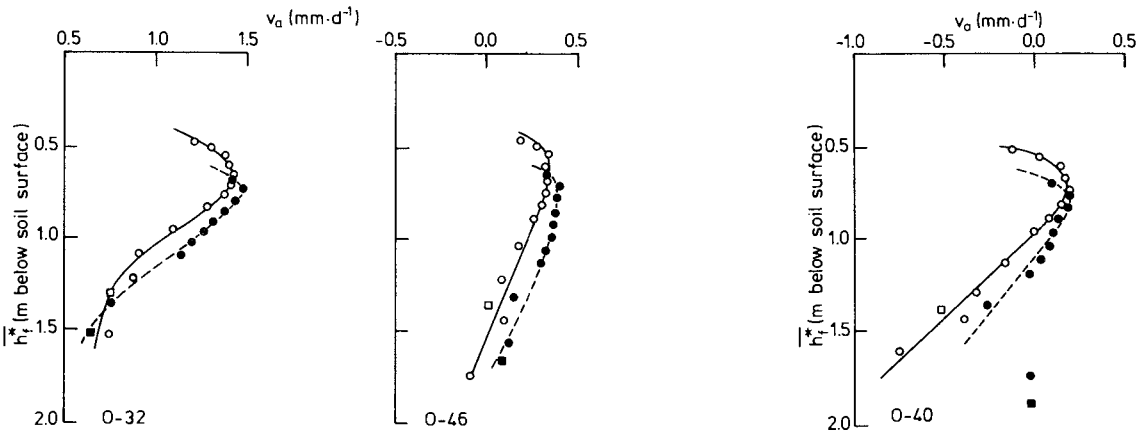

Fig. 9.4. The relationship $v_a = f(\overline{h_f^*}, h_o^*)$ of sections O-32 and O-46, calculated with FEMSATS, type D

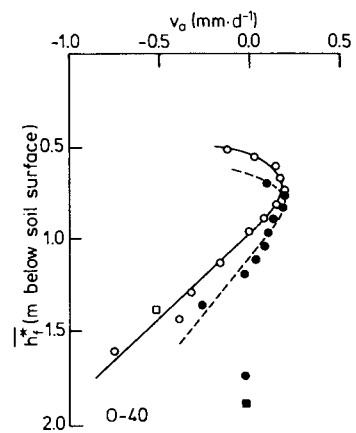

Fig. 9.5. The relationship $v_a = f(\overline{h_f^*}, h_o^*)$ of section O-40, calculated with FEMSATS, type E

Square symbols indicate results for the case capillary rise is a function of h_f^* . In general, these points differ only slightly from the general $v_a = f(\overline{h_f^*}, h_o^*)$ -relationships as simulated with a constant

value of v_f throughout the area. This result supports the conclusion in Chapter 6 that it is acceptable to impose one value for v_f as upper boundary condition for FEMSATS.

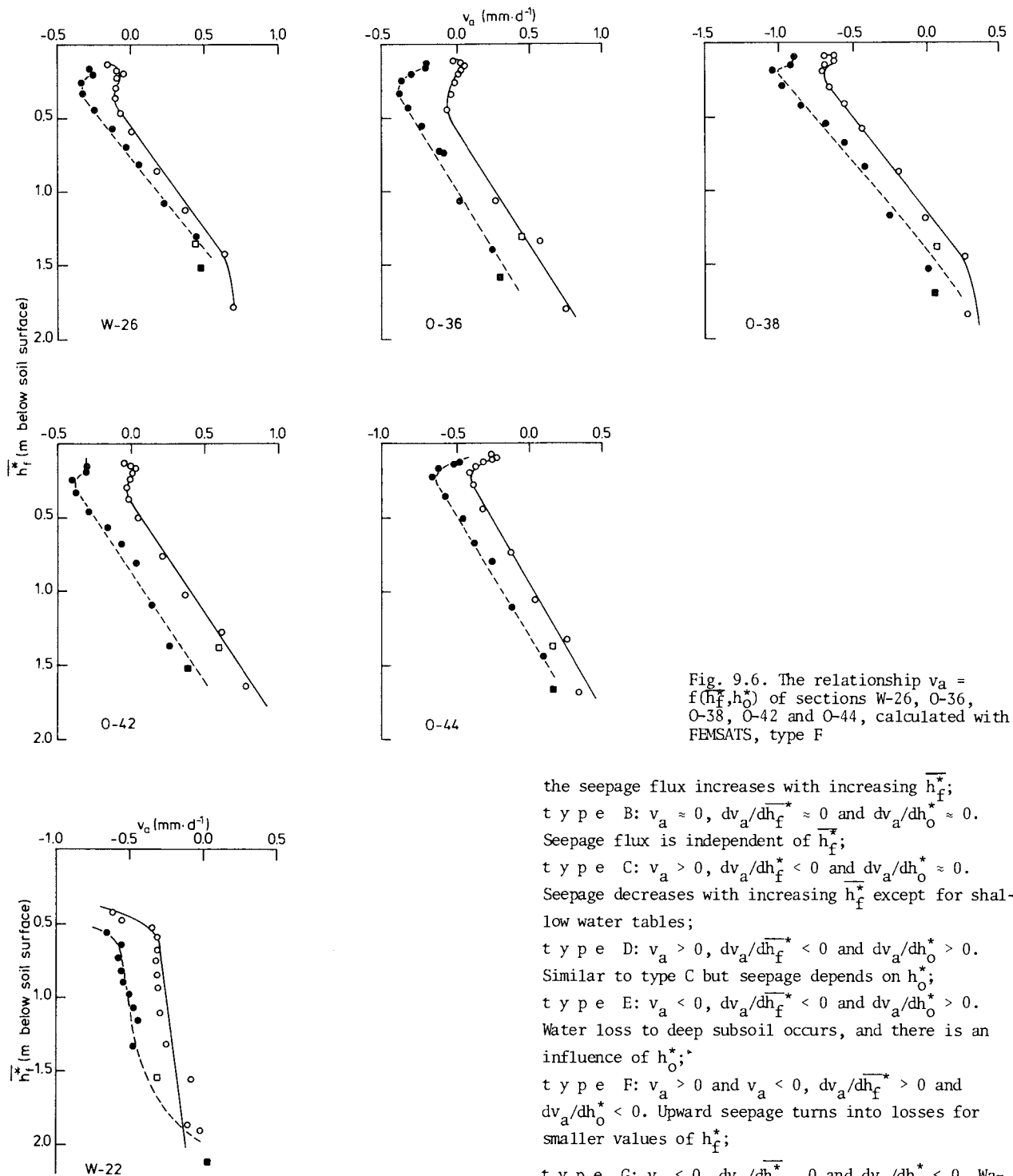

Fig. 9.6. The relationship $v_a = f(\bar{h}_f^*, h_o^*)$ of sections W-26, O-36, O-38, O-42 and O-44, calculated with FEMSATS, type F

Fig. 9.7. The relationship $v_a = f(\bar{h}_f^*, h_o^*)$ of section W-22, calculated with FEMSATS, type G

In the simulated relationships $v_a = f(\bar{h}_f^*, h_o^*)$ per section, a distinction has been made between the following types (Figs. 9.1 through 9.7):

type A: $v_a > 0$, $dv_a/d\bar{h}_f^* > 0$ and $dv_a/dh_o^* \approx 0$. So

- the seepage flux increases with increasing \bar{h}_f^* ;
- type B: $v_a \approx 0$, $dv_a/d\bar{h}_f^* \approx 0$ and $dv_a/dh_o^* \approx 0$. Seepage flux is independent of \bar{h}_f^* ;
- type C: $v_a > 0$, $dv_a/d\bar{h}_f^* < 0$ and $dv_a/dh_o^* \approx 0$. Seepage decreases with increasing \bar{h}_f^* except for shallow water tables;
- type D: $v_a > 0$, $dv_a/d\bar{h}_f^* < 0$ and $dv_a/dh_o^* > 0$. Similar to type C but seepage depends on h_o^* ;
- type E: $v_a < 0$, $dv_a/d\bar{h}_f^* < 0$ and $dv_a/dh_o^* > 0$. Water loss to deep subsoil occurs, and there is an influence of h_o^* ;
- type F: $v_a > 0$ and $v_a < 0$, $dv_a/d\bar{h}_f^* > 0$ and $dv_a/dh_o^* < 0$. Upward seepage turns into losses for smaller values of h_o^* ;
- type G: $v_a < 0$, $dv_a/d\bar{h}_f^* \approx 0$ and $dv_a/dh_o^* < 0$. Water losses to deep subsoil without influence of h_o^* .

As can be seen from Figs. 9.1 through 9.7, the seepage flux averaged over a section reacts on changes in \bar{h}_f^* and sometimes on h_o^* . The different $v_a = f(\bar{h}_f^*, h_o^*)$ -relationships per section are used as part of the lower boundary condition for the unsaturated zone.

9.4. GROSS HYDROLOGICAL EFFECTS OF CONSERVATION AND WATER SUPPLY

To arrive at the gross hydrological effects for each section a representative soil physical unit, a representative T-value and a $v_a = f(h_f^*, h_0^*)$ -relationship as described in the previous section were determined

SWAMP is a one-dimensional model which simulates the hydrological processes in one point per section, the 'reference simulation point'. Per reference simulation point the surface water management strategies I through V, mentioned in the introduction of this chapter have been simulated for the period 1971-1982. The results of the simulations in terms of average transpiration and amounts of supplied water are given

in Table 9.1. The figures for the subregions and the whole region are the weighted averages of the sections.

The effects of conservation and water supply and efficiencies of water supply have been defined as follows:

- average yearly effect of conservation:

$$\overline{\Delta T_c} = \overline{E_t \text{ (II)}} - \overline{E_t \text{ (I)}} \quad (\text{mm} \cdot \text{a}^{-1})$$

- average yearly effect of water supply:

$$\overline{\Delta T_{0.75}} = \overline{E_t \text{ (III)}} - \overline{E_t \text{ (II)}} \quad (\text{mm} \cdot \text{a}^{-1})$$

where the subscript 0.75 stands for $s_m = 0.75 \text{ mm} \cdot \text{d}^{-1}$. Definitions of $\overline{\Delta T_{1.50}}$ and $\overline{\Delta T_{2.50}}$ are similar

Table 9.1. Average yearly transpiration, $\overline{E_t}$, and amounts of water supply per unit area, $\overline{v_{o,p}}$, per section, per subregion and of the whole region 'De Monden' for five alternatives of surface water management during the period 1971-1982, simulated with SWAMP

Section, (sub)-region	Gross area (ha)	Soil physical unit	T (d)	Surface water management alternatives									
				I (fixed weir)		II (conservation)		III (water supply $s_m = 0.75 \text{ mm} \cdot \text{d}^{-1}$)		IV (water supply $s_m = 1.50 \text{ mm} \cdot \text{d}^{-1}$)		V (water supply $s_m = 2.50 \text{ mm} \cdot \text{d}^{-1}$)	
				$\overline{E_t}$ ($\text{mm} \cdot \text{a}^{-1}$)	$\overline{v_{o,p}}$ ($\text{mm} \cdot \text{a}^{-1}$)	$\overline{E_t}$ ($\text{mm} \cdot \text{a}^{-1}$)	$\overline{v_{o,p}}$ ($\text{mm} \cdot \text{a}^{-1}$)	$\overline{E_t}$ ($\text{mm} \cdot \text{a}^{-1}$)	$\overline{v_{o,p}}$ ($\text{mm} \cdot \text{a}^{-1}$)	$\overline{E_t}$ ($\text{mm} \cdot \text{a}^{-1}$)	$\overline{v_{o,p}}$ ($\text{mm} \cdot \text{a}^{-1}$)	$\overline{E_t}$ ($\text{mm} \cdot \text{a}^{-1}$)	$\overline{v_{o,p}}$ ($\text{mm} \cdot \text{a}^{-1}$)
1	2	3	4	5	6	7	8	9	10	11	12		
W-1	320	I	200	251.0	257.9	260.1	32.3	261.5	46.8	261.5	46.8		
W-16	330	I	200	226.4	256.8	256.9	19.9	256.3	32.0	256.3	32.0		
W-18	239	IV	300	252.6	258.0	260.4	31.2	261.7	46.1	262.5	47.2		
W-22	183	XI	200	246.1	254.1	265.0	62.9	272.4	103.6	276.4	119.9		
W-22	330	IV	300	252.6	258.0	260.4	31.2	261.6	46.7	262.5	47.0		
W-26	474	VII	350	246.2	250.7	253.0	30.0	254.9	45.4	255.3	48.2		
Western sub-region	1876			250.9	255.5	258.9	32.2	260.0	49.3	260.7	51.8		
M-22	584	XI	150	257.6	272.7	279.9	46.3	284.3	73.3	285.2	88.9		
M-24	329	XI	300	260.1	272.0	277.2	46.2	279.7	67.3	281.5	77.0		
M-26	828	VII	115	231.4	255.1	259.1	37.6	259.9	57.7	261.5	67.9		
M-34	666	XI	150	259.3	276.2	281.5	42.0	284.4	63.3	286.1	71.7		
M-36	430	XI	275	256.7	271.1	277.4	49.4	279.7	72.8	281.8	85.3		
Middle sub-region	2837			250.5	268.1	273.5	43.2	276.0	65.6	277.5	76.8		
O-32	166	XI	120	271.6	284.1	287.5	30.1	288.4	44.1	289.6	47.2		
O-34	402	VII	140	235.3	250.7	256.7	35.4	259.4	53.4	261.4	83.9		
O-36	348	VIII	175	215.0	225.9	237.0	40.4	244.1	59.1	246.1	65.9		
O-38	366	XI	240	256.6	270.5	278.1	50.1	281.5	75.3	283.3	89.1		
O-40	100	VII	270	229.9	246.7	251.8	39.4	254.3	58.8	255.8	62.2		
O-42	248	XI	350	267.5	272.5	276.8	39.7	278.3	54.6	280.1	56.2		
O-44	248	XI	540	265.4	270.0	272.8	40.8	274.6	56.5	275.1	56.2		
O-46	250	VIII	150	220.1	229.2	239.4	39.8	244.7	55.5	246.7	65.6		
Eastern sub-region	2128			243.7	254.7	261.5	40.2	265.0	58.4	266.7	69.4		
Whole region	6814			248.5	260.5	265.8	39.2	268.2	58.9	269.5	67.6		

Table 9.2. Average yearly gross effects per unit area of water conservation, $\overline{\Delta T_C}$, water supply, $\overline{\Delta T_S}$, and efficiencies of water supply, $\overline{e_w}$, per subregion and for the whole region 'De Monden'

(Sub)region	$\overline{\Delta T_C}$ (mm·a ⁻¹)	$\overline{\Delta T_{0.75}}$ (mm·a ⁻¹)	$\overline{e_{0.75}}$ (%)	$\overline{\Delta T_{1.50}}$ (mm·a ⁻¹)	$\overline{e_{1.50}}$ (%)	$\overline{\Delta T_{2.50}}$ (mm·a ⁻¹)	$\overline{e_{2.50}}$ (%)
West	4.6	3.4	10.5	4.5	9.1	5.2	10.0
Middle	17.6	5.4	12.5	7.9	12.0	9.4	12.2
East	11.0	6.8	16.9	10.3	17.5	12.0	17.7
'De Monden'	12.0	5.3	13.5	7.7	13.1	9.0	13.3

Table 9.3. Simulated effects of water conservation and water supply on actual transpiration, $\overline{E_t}$, expressed as percentage of potential transpiration, $\overline{E_{t,p}}$, per subregion and for the whole region 'De Monden', averaged over the period 1971-1982

(Sub)region	$\overline{\Delta T_C}/\overline{E_{t,p}}$ (%)	$\overline{\Delta T_{0.75}}/\overline{E_{t,p}}$ (%)	$\overline{\Delta T_{1.50}}/\overline{E_{t,p}}$ (%)	$\overline{\Delta T_{2.50}}/\overline{E_{t,p}}$ (%)
West	1.56	1.15	1.52	1.76
Middle	5.96	1.83	2.67	3.18
East	3.72	2.30	3.49	4.06
'De Monden'	4.04	1.79	2.60	3.05

- average yearly efficiency of water supply:

$$\overline{e_{0.75}} = (\overline{\Delta T_{0.75}}/\overline{v_{0.75}}) \times 100\%$$

where $\overline{v_{0.75}}$ is average yearly amount of supplied water with $s_m = 0.75 \text{ mm}\cdot\text{d}^{-1}$. For $s_m = 1.5$ and 2.5 definitions are similar.

These results per subregion and for the whole area are given in Table 9.2.

Finally in Table 9.3 the different effects are given as percentage of the average yearly potential transpiration, $\overline{E_{t,p}}$ (i.e. $295.4 \text{ mm}\cdot\text{a}^{-1}$).

All tables show that the effects of water conservation and supply in the western subregion are lower than elsewhere. Probably this is caused by a seepage flow into this region from the Hondsrug ridge. Another reason may be the estimation of soil physical properties. The most occurring soil physical unit in this subregion is unit I. From the analysis of remote sensing images (Chapter 6) it already has been concluded that the capillary conductivity of this unit has probably been underestimated.

The effects of water supply do not increase proportionally with supply capacity. This is mainly because in wetter years the higher capacities are not utilized.

9.5. CORRECTIONS ON THE GROSS HYDROLOGICAL EFFECTS

The effects of water conservation and water supply given in Table 9.2 would be true if the whole area of 6814 ha was covered completely with a good growing potato crop, the meteorological data would be represen-

tative for the local climate, the soil surface was completely horizontal and flat and no roads, etc. would be present. Because this is not the case, a number of corrections has to be applied. Besides, a correction has to be applied for expected future changes in soil-physical properties.

Correction for meteorological data

First of all the question whether the meteorological data of the period 1971-1982 are representative for a longer period has to be answered. A good measure for the degree of dryness of a particular year proved to be the maximum value of the water deficit in the root zone, $W_{r,d}$, calculated by assuming a potential transpiration rate. WIEBING (1982, pers. comm.) calculated these yearly maximum values during the period 1945-1982 for a potato crop, using meteorological data of Eelde. The average value of $W_{r,d}$ over the period 1945-1982 was 150 mm; that over the period 1971-1982 167 mm. The latter period, therefore, was approximately 10% drier. Therefore it was decided to reduce the gross effects, obtained over the period 1971-1982, by 10%.

Correction for crop related data

The standard potato crop used in the model can be classified as a middle-late ripening one. In practice there are early, middle-late and late-ripening varieties grown, but the standard crop is assumed to be representative for all varieties.

The sugar beets (30%) and cereals (20%) in the area are actually accounted for in the following way. With the SWADRE-model the effects of conservation and water supply on transpiration of sugar beets and win-

Table 9.4. Comparison between simulated yearly effects of water conservation and water supply, ΔT_C and ΔT_S on the transpiration of potatoes and the corresponding effects for a cropping pattern with 50% potatoes, 30% sugar beets and 20% winter wheat

Year	ΔT_C (mm·a ⁻¹)		ΔT_S (mm·a ⁻¹)	
	potatoes	cropping pattern	potatoes	cropping pattern
1971	19.0	18.1	7.1	10.3
1975	17.3	19.9	19.1	17.8
Average	18.2	18.5	13.1	14.0

ter wheat for the years 1971 and 1975 were simulated. These years have been selected because they did show considerable but not extremely high effects of conservation and water supply on the transpiration of the potato crop. With the results the weighted effects of water conservation and supply in 1971 and 1975 for the actual cropping pattern in 'De Monden' have been derived. Table 9.4 gives the results compared with the simulated effects of the potato crop. Because differences are small it has been concluded that the standard potato crop can be considered representative for the cropping pattern as a whole.

The standard potato crop is assumed to be free of diseases and to grow equally well at each location in the field. In practice, however, both diseases and less favourable growing conditions on headlands and along the edges of parcels result in a lower transpiration per unit area than calculated for the reference simulation point. These conditions will be accounted for when converting additional transpiration into crop production.

Correction for gross - net area

From data of SLOTHOUWER (1982) it can be derived that of the gross area 76% is used by agriculture, the remainder being occupied by roads, farmyards, water, buildings, etc. The area occupied by the surface water system is about 6% of the gross area and is accounted for in the model. This means that 18% of the gross area is not modeled. It has been assumed that about half of this area receives water, but gives no effects of surface water management. This results in a decrease of the water supply efficiency of 10% (e.g. $\bar{e}_w = 10\%$ becomes $\bar{e}_w = 9\%$). To find the hydrological effects per unit surface therefore only 82% of the gross area, given in Table 9.1, has to be taken.

Correction for unevenness of the soil surface

As can be seen from the elevation map (Fig. 3.5) the elevation of the soil surface within each section

is varying. The contour lines reflect only the regional and local trends in elevation and do not show smaller differences in micro-relief. Spots with a lower or higher elevation than the reference simulation point will respond in a different way.

To investigate the consequences of the unevenness the hydrological processes during 1971-1982 have been simulated with different elevations of the soil surface, different water management strategies and different soil physical units. The results of the simulations are given in Fig. 9.8 in terms of \bar{E}_t and soil surface elevation. The curves in this figure show that the relation between soil surface elevation and

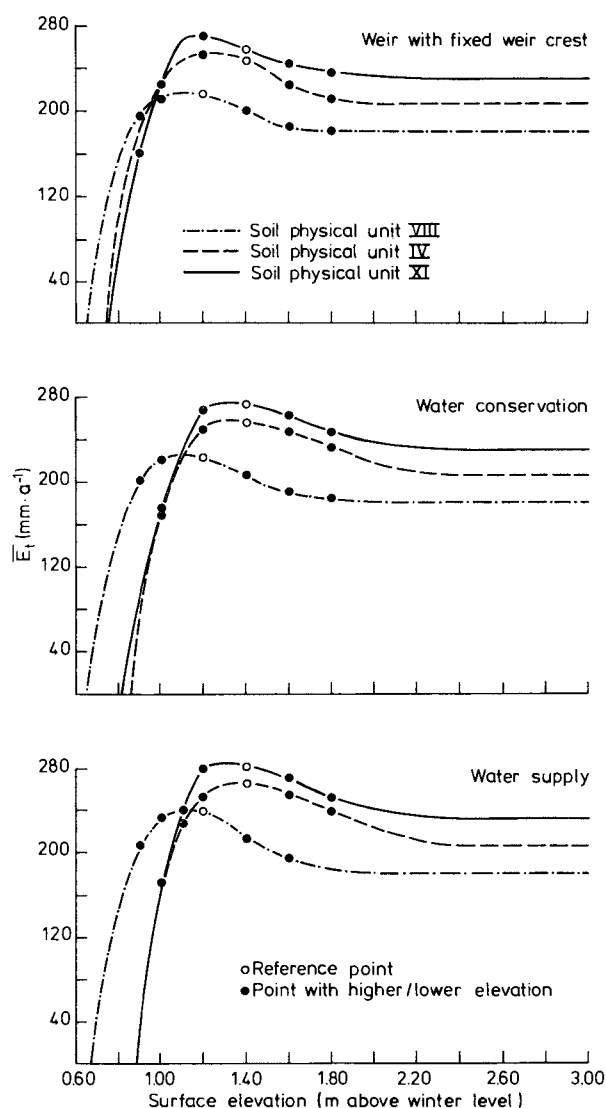

Fig. 9.8. Average yearly transpiration of potatoes growing on soil physical units IV, VIII and XI, \bar{E}_t , as function of height of the soil surface, calculated with SWAMP for three alternative ways of surface water management

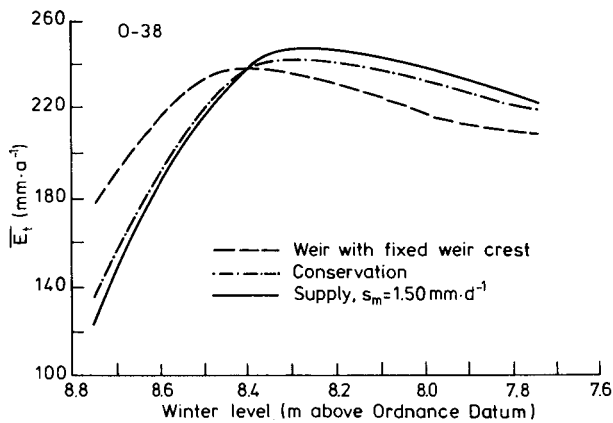

Fig. 9.9. Average yearly transpiration of potatoes, \bar{E}_t , of section O-38 derived from the relations in Fig. 9.8, for three alternative ways of surface water management

the average yearly transpiration has an optimum, that varies with soil physical unit and water management employed. Furthermore \bar{E}_t decreases sharply for soil surface elevations less than 1.00 m above winter level, as a result of increasing waterlogging damage.

Next five sections were selected. Per section soil physical units and elevation at a great number of locations were determined, using the soil map 1:50 000 and a map with point elevation values. With the aid of this data each section was subdivided into a number of combinations of surface elevation and soil physical unit, applying elevation classes of 5 cm and the soil physical units given in Fig. 9.8. For each combination the \bar{E}_t -values for a given winter water level and for the three surface water management alternatives were read from the curves in Fig. 9.8. Averaging all \bar{E}_t -values per section yielded the average yearly value of \bar{E}_t for an entire section. Repeating these calculations with different winter levels yielded a relationship between winter level and \bar{E}_t for each of the 5 selected sections. In Fig. 9.9 an exam-

ple is shown. The optimal depths of winter level and the corresponding \bar{E}_t are given in Table 9.5. The optimal depth of a fixed weir crest is approximately 1.40 m below average soil surface. With conservation the optimal winter level is approximately 1.50 m, while with water supply this depth is approximately 1.55 m. From Table 9.5 also the effects of conservation and water supply per section follow. In Table 9.6 these effects are compared with the effects computed for a flat surface and with elevation equal to that in the reference simulation point. Averaged over five sections the effects are reduced by unevenness to 74% and 64% of the values for flat land for conservation and water supply, respectively.

By oxydation of organic matter the unevenness may increase, because the soil profiles in the lowest places normally have a higher organic matter content and a thicker peat layer in the subsoil. Assuming lowering of the soil surface between zero and 0.15 m, depending on soil type, the above mentioned reductions did not change more than 3%. Therefore the influence of future changes in soil surface elevation has been ignored.

Table 9.6. Comparison between the average yearly effects of water conservation, ΔT_C , and water supply, ΔT_S , corresponding to an uneven soil surface and ΔT_C and ΔT_S corresponding to a flat soil surface, in five selected sections of 'De Monden'

Section	ΔT_C (mm·a ⁻¹)		ΔT_S (mm·a ⁻¹)	
	uneven soil surface	flat soil surface	uneven soil surface	flat soil surface
W-24	6.0	7.6	5.0	8.4
W-26	5.0	6.4	6.0	8.1
O-34	5.0	7.9	6.0	8.8
O-38	6.0	6.8	5.0	8.4
O-42	6.0	9.3	6.0	10.4
Average	5.6	7.6	5.6	8.8

Table 9.5. Optimal depth of weir crest or winter level relative to the mean height of the soil surface of a section and corresponding transpiration for the period 1971-1982 and averaged over a section, \bar{E}_t , of three alternatives of surface water management, in five selected sections of 'De Monden'

Section	I (fixed weir)		II (conservation)		III (supply, $s_m = 1.50 \text{ mm} \cdot \text{d}^{-1}$)	
	weir crest (m below soil surface)	\bar{E}_t (mm·a ⁻¹)	winter level (m below soil surface)	\bar{E}_t (mm·a ⁻¹)	winter level (m below soil surface)	\bar{E}_t (mm·a ⁻¹)
W-24	1.50	237	1.60	243	1.65	248
W-26	1.40	239	1.52	244	1.55	250
O-34	1.40	238	1.50	243	1.55	249
O-38	1.35	239	1.50	245	1.52	250
O-42	1.45	225	1.50	231	1.55	237
Average	1.40	235.6	1.52	241.2	1.56	246.8

Fig. 9.10. Schematic representation of influence of location of reference simulation point on flow resistance to the watercourse

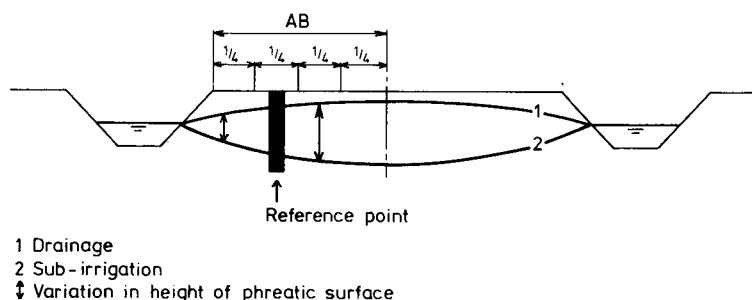

From the simulation results the influence of unevenness of the soil surface on the average yearly amount of water supply $\overline{v_{o,p}}$; and on the average yearly efficiency of water supply, $\overline{e_w}$, could not be derived. Assuming that $\overline{e_w}$ remains the same for all elevations, $\overline{v_{o,p}}$ would decrease with 36%. In relatively low places, $\overline{e_w}$ can become negative. In relatively high places $\overline{e_w}$ may be decreased because the distance between groundwater table and root zone becomes too great to give a sufficient capillary rise. Groundwater will flow from these places to places with capillary rise and the supply will be less than calculated. This kind of local groundwater flow cannot be accounted for in SWAMP. As a guess it therefore has been assumed that on 80% of the area $\overline{e_w}$ remains the same as in the reference simulation point and on 20% it becomes zero, so that $\overline{e_w}$ reduces with 20%. Combined with a 36% lower effect of water supply, $\overline{v_{o,p}}$ of a section becomes 20% lower than has been calculated for the reference simulation point.

Correction for the shape of the phreatic surface

The location of the reference simulation point is that particular place where $h_f = \overline{h_f}$ (see also Fig. 5.4). In order to investigate whether it is necessary to correct for the shape of the phreatic surface the parcel AB in Fig. 9.10 has been divided into 4 strips, each with a width of 20 m. The centre of each strip is taken as representative.

For each strip $\overline{\Delta T_c}$ and $\overline{\Delta T_{1.5}}$ have been simulated. The results show that $\overline{\Delta T_c}$ and $\overline{\Delta T_{1.5}}$ of the reference simulation point are 10% and 3% larger than $\overline{\Delta T_c}$ and $\overline{\Delta T_{1.5}}$ averaged over the entire parcel (strips 1 through 4).

Correction for future changes in soil physical properties

The soil mapping units of soil map 1:50 000 are the 'carriers' of the soil physical properties. However, the soil physical properties change with time for three reasons:

- The decomposition of organic matter is faster than the supply. With certain assumptions about the decomposition rate it can be calculated that within 30 years, roughly the following changes will occur:
 - deep peat soils (zVc, aVc, iVc, aVz) lose part of the organic matter but remain peat soils;
 - moderate deep peat soils (iVz, iVp) change into peaty soils;
 - peaty soils (iWz, iWp, zWz) change into sandy soils;
 - in sandy soils (Hn21, pZn21) the water retention capacity of the root zone will diminish.
- The soil physical properties drastically change by soil improvement (see Chapter 4).
- As a result of deeper cultivation and subsoil liming the thickness of the root zone can increase, especially in soil types with a root zone of only 0.20 m.

The changes described above will affect the values of $\overline{\Delta T_c}$, $\overline{\Delta T_s}$ and $\overline{e_w}$. Because the benefits of investments stretch over a period of 30 to 50 years, it is necessary to estimate the potential influences of such changes.

The effects of a transformation of a moderate deep peat soil into a peaty soil have been estimated by comparing the soil physical units IV (iVz, iVp) and V (iWz). The simulated values of $\overline{\Delta T_c}$ are 5.1 and 17.6 $\text{mm}\cdot\text{a}^{-1}$ respectively; of $\overline{\Delta T_s}$ 8.3 and 9.6 $\text{mm}\cdot\text{a}^{-1}$ respectively. It has been estimated that this change will happen in 10% of the area.

The effects of a transformation of a peaty soil into a sandy soil have been estimated by comparing soil physical unit V (iWz) and VIII (Hn21, pZn21). The simulated values of $\overline{\Delta T_c}$ are 17.6 and 8.5 $\text{mm}\cdot\text{a}^{-1}$ respectively; of $\overline{\Delta T_{1.5}}$ 9.6 and 15.8 $\text{mm}\cdot\text{a}^{-1}$. This change will manifest itself in about 15% of the area.

Already a considerable part of the area has been improved, but roughly 20% of the area still is potentially improvable. The effects have been estimated

Table 9.7. Change in average yearly effects of water conservation and water supply owing to a decrease in soil water retention capacity, caused by soil degradation

Soil physical unit	Effect of conservation, $\overline{\Delta T_C}$ (mm·a ⁻¹)		Effect of water supply, $\overline{\Delta T_S}$ (mm·a ⁻¹)	
	reference profile	degraded profile	reference profile	degraded profile
XI	14.1	12.8	9.4	7.8
VIII	8.5	16.9	15.8	14.2

by comparing soil physical unit VII (iWp) and XI (improved iWp) giving a $\overline{\Delta T_C}$ of 17.6 and 14.1 mm·a⁻¹ respectively; $\overline{\Delta T_{1.5}}$ is 9.6 and 9.4 mm·a⁻¹ respectively.

To estimate the effects of a decrease in water retention capacity caused by decomposition of organic matter the following changes have been assumed. The soil water retention capacity corresponding with a groundwater depth of 1.00 m of root zone and subsoil of soil physical unit XI (improved peaty soil) decreases from 181 to 170 and from 645 to 632 mm respectively. The soil water retention capacity of the root zone of soil physical unit VIII (podsol) decreases from 82 to 62 mm. The effects of these changes have been simulated with SWAMP for the period 1971-1982 and the average values are given in Table 9.7. It has been estimated that the degradation of improved peaty soils is relevant for 40% of the area, the degradation of sandy soils for 10% of the area.

The total effect of all possible changes in soil physical properties has been determined by taking into account the areas for which the particular change is relevant. This procedure has resulted in a decrease of the effect of water conservation of 15%, while the effect of water supply increases with 10%. Changes in water supply efficiency have not been investigated but it

Table 9.8. Summary of possible systematic corrections on the average yearly hydrological effects of water conservation, $\overline{\Delta T_C}$, and water supply, $\overline{\Delta T_S}$, and on average yearly efficiency of water supply, $\overline{e_w}$, calculated with SWAMP

	Correction for $\overline{\Delta T_C}$ (%)	Correction for $\overline{\Delta T_S}$ (%)	Correction for $\overline{e_w}$ (%)
Meteorological data	-10	-10	0
Crop related data (Table 9.3)	0	0	-
Gross-net area	-	-	-10
Unevenness of soil surface (Table 9.4)	-26	-36	-20
Shape of phreatic surface	-10	-3	0
Changes in soil physical properties	-15	+10	0
Overall corrections	-50	-30	-30

has been estimated that $\overline{e_w}$ practically will not change.

9.6. NET HYDROLOGICAL EFFECTS OF WATER CONSERVATION AND WATER SUPPLY

The corrections discussed in the previous section are summarized in Table 9.8. The last row gives the overall corrections, as obtained by the product rule for percentages. These overall corrections, if applied to the values obtained earlier, result in the data shown in Table 9.9.

In Chapter 7 a more 'restrictive' surface water management has been mentioned (run 11 in Table 7.4). For the reference (for the definition, see Section 7.2) $\overline{\Delta T_C}$ was about 40% lower, while $\overline{\Delta T_S}$ and $\overline{v_{o,p}}$ increased with some 40% and 20% respectively. Applying these percentages gives the estimation of the net effects of a restrictive surface water management given in the last row of Table 9.9. It must be emphasized

Table 9.9. Average yearly net hydrological effects, per unit area and as percentage of potential transpiration, of water conservation/water supply together with average yearly amounts of water supply per unit area in three subregions and in the whole region 'De Monden' obtained from correction of the gross hydrological effects, given in Tables 9.2 and 9.3

(Sub)region	Conservation		Supply, $s_m = 0.75 \text{ mm}\cdot\text{d}^{-1}$			Supply, $s_m = 1.50 \text{ mm}\cdot\text{d}^{-1}$			Supply, $s_m = 2.50 \text{ mm}\cdot\text{d}^{-1}$		
	$\overline{\Delta T_C}$ (mm·a ⁻¹)	$\overline{\Delta T_C}$ (%)	$\overline{\Delta T_{0.75}}$ (mm·a ⁻¹)	$\overline{\Delta T_{0.75}}$ (%)	$\overline{v_{o,p}}$ (mm·a ⁻¹)	$\overline{\Delta T_{1.50}}$ (mm·a ⁻¹)	$\overline{\Delta T_{1.50}}$ (%)	$\overline{v_{o,p}}$ (mm·a ⁻¹)	$\overline{\Delta T_{2.50}}$ (mm·a ⁻¹)	$\overline{\Delta T_{2.50}}$ (%)	$\overline{v_{o,p}}$ (mm·a ⁻¹)
West	2.5	0.79	2.4	0.81	32.6	3.2	1.06	50.2	3.6	1.23	51.4
Middle	8.8	2.98	3.8	1.28	43.4	5.5	1.87	65.5	6.6	2.23	77.3
East	5.5	1.86	4.8	1.61	40.6	7.2	2.44	58.8	8.9	2.84	71.8
'De Monden'	6.0	2.02	3.7	1.25	39.5	5.4	1.82	59.4	6.3	2.14	67.2
'Restrictive' management	3.6	1.21	5.2	1.75	47.4	7.6	2.55	71.3	8.8	3.00	80.6

that these figures are not the result of simulations, but merely the outcome of applying the above mentioned percentages. This table has been used as a basis for the determination of the economical effects of water conservation and water supply (see Chapter 11). The main aim of using the figures for restrictive management is to show the sensitivity of the operational rules applied on these effects.

The figures in Table 9.9 could suggest that the hydrological effects have been determined with a high degree of accuracy. The sensitivity analysis, however, shows that the effects in reality may differ considerably from the simulated ones. Besides a number of secondary effects of surface water management have not taken into account (see Chapter 10). The figures in Table 9.9 therefore must be considered as a best estimate, free of systematic errors. Because it is difficult to base engineering decisions such as the construction of weirs, etc. on a distribution function of possible effects of water conservation and supply, the approach of the best estimates followed here remains necessary. The presence of a certain scatter in possible effects must certainly be kept in mind.

10. OTHER ASPECTS OF SURFACE WATER MANAGEMENT

10.1. INTRODUCTION

In Chapter 9 the net hydrological effects of surface water management have been treated. In this chapter some other aspects will be discussed.

Water conservation and water supply not only involves the construction of weirs and inlet structures, but also the choice of an operating system. The proposed operational rules are partly based upon groundwater observations. In Sections 10.2 and 10.3 the required number and the location of piezometers will be discussed.

In the previous chapter it has been assumed that all watercourses of the tertiary system were well-maintained. This, however, is not the case, and in Section 10.4 the influence of this maintenance will be examined.

Pipe drainage is uncommon in the area, but its installation in future may influence the effects of surface water management. This question will be dealt with in Section 10.5.

In Chapter 9 it was found that the unevenness of the soil surface has a considerable influence. The size of a section may influence this conclusion; this will be verified in Section 10.6.

Construction of weirs and inlet structures will influence the flow of water in the watercourses. In Section 10.7 the hydraulic aspects will be treated.

Finally, in Section 10.8, a number of secondary effects of surface water management will be treated.

10.2. LOCATION OF REFERENCE PIEZOMETER

In SWAMP the surface water management is governed by the depth of the groundwater and the water storage in the root zone at one reference simulation point. Due to unevenness of the soil surface the winter level below the average soil surface of a whole section may differ from the depth of the winter level in the reference simulation point (Table 9.5). In case of conservation, the optimal depth of the winter level should be 1.52 m below the mean level of the soil surface of a section, whereas the winter level was only 1.40 m below the soil surface in the reference point. With water supply these values were 1.56 m and 1.40 m respectively. In these cases the level

of the reference simulation point did not coincide with the mean level of the soil surface of a section, but was situated 0.12 m (conservation) and 0.16 m (water supply) lower. A waterboard, that wants to operate with surface water levels according to the operational rules discussed in Chapter 7, must situate its reference piezometer about 0.15 m lower than the average height of the soil surface of a section.

Another problem with the location of a reference piezometer is its position with respect to the watercourses. In an area like 'De Monden', with an average distance between two watercourses of 200 m and a shape factor $n_f = 0.80$, a point about 30 m away from a watercourse coincides with the point where $h_f = \bar{h}_f$ (see also Fig. 9.10). In general, this position will be in a field, which may cause inconvenience. If a location midway between two watercourses is chosen, a larger variation in depth of groundwater table occurs, and a correction should be applied.

10.3. NUMBER OF REFERENCE PIEZOMETERS

Applying SWAMP for surface water management requires a reference point in each section. An important question for the waterboard is whether one reference point can be used for several sections to reduce the number of observations. From the figures in Table 5.2 it can be concluded that there exists a close correlation between the different piezometers. Therefore, it should not be necessary to have a reference piezometer for each section.

To test whether it is allowed to use a limited number of reference piezometers the following model experiment has been performed. Two hydrologically different sections with the same groundwater depth classification has been chosen, viz. M-36 ($T = 275$ days and $v_a < 0.0 \text{ mm}\cdot\text{d}^{-1}$) and M-22 ($T = 100$ days and $v_a > 0.0 \text{ mm}\cdot\text{d}^{-1}$). Data of the reference simulation point of section M-36 have been used as input for section M-22. The hydrological effects of water supply for M-22, calculated in this way, were compared with those obtained by using data from M-22 itself. The result was that ΔT_s changed from 11.6 to 10.9 $\text{mm}\cdot\text{a}^{-1}$, while $\bar{v}_{0,p}$ increased from 73.3 to 75.8 $\text{mm}\cdot\text{a}^{-1}$. Hence, it has been concluded that it is allowed to reduce the number of reference piezometers. A possi-

ble recommendation is to chose one reference piezo-meter per groundwater depth class.

10.4. INFLUENCE OF MAINTENANCE OF SMALL CANALS

In earlier simulations, good maintenance of the watercourses has been assumed. From the sensitivity analysis maintenance conditions of the 'wijken' turned out to have a large influence, not only on the effects of water conservation and water supply, but also on the actual transpiration in the zero situation (Table 8.3).

To get a better insight in the effects of cleaning all 'wijken', the transpiration of potatoes per section during the period 1971-1982 has been simulated with SWAMP for water supply with $s_m = 1.50 \text{ mm}\cdot\text{d}^{-1}$ and watercourses partly overgrown by water weeds. The latter condition is representative for the present situation. Compared with the same situation, but 'wijken' all cleaned, $\overline{T}_{1.50}$ for the western, middle and eastern subregion decreased with 58.5, 10.4 and $24.3 \text{ mm}\cdot\text{a}^{-1}$ respectively, corresponding with 23, 5 and 9% of $\overline{E}_{t,p}$. For the whole region $\overline{T}_{1.50}$ decreased from 268.1 to $240.3 \text{ mm}\cdot\text{a}^{-1}$ (10%), while $\overline{v}_{o,p}$ only decreased from 58.9 to $57.3 \text{ mm}\cdot\text{a}^{-1}$. The negative effects of non-optimal maintenance of the 'wijken' therefore are considerable, especially in the western region where, in general, upward seepage occurs ($v_a > 0$). It may be expected that in future the small canals will be cleaned and maintained, so that the earlier simulations will become representative.

10.5. CONSEQUENCES OF INSTALLATION OF PIPE DRAINAGE

One of the results of the sensitivity analysis was that the effect of water supply, $\overline{\Delta T}_s$, depends on the value of the drainage resistance T . In practice T can be decreased by installing pipe drainage. This is only done when considerable waterlogging damage occurs. According to the curves depicting the relation between winter level and \overline{E}_t (Fig. 9.8), waterlogging damage becomes important if the soil surface is less than 1.20 m above the weir crest or winter level. Therefore it has been assumed that pipe drainage only is relevant for places with an elevation less than 1.20 m below winter level and that it will be used for both drainage and sub-irrigation.

The consequences of the installation of pipe drainage at these places have been computed by applying the following steps:

- three reference simulation points have been defined viz. soil physical units IV, VIII and XI, all three having $T = 200$ days;
- points which have an elevation of 0.20 m or more below the elevation of the reference point have been assumed to get a pipe drainage system. This reduces the drainage resistance T from 200 to 50 days;
- with the simulated surface water levels for the three reference points the transpiration for the surface water management alternatives I, II and IV (Section 9.1) was simulated and depicted as a function of height above winter level. In Fig. 10.1 the

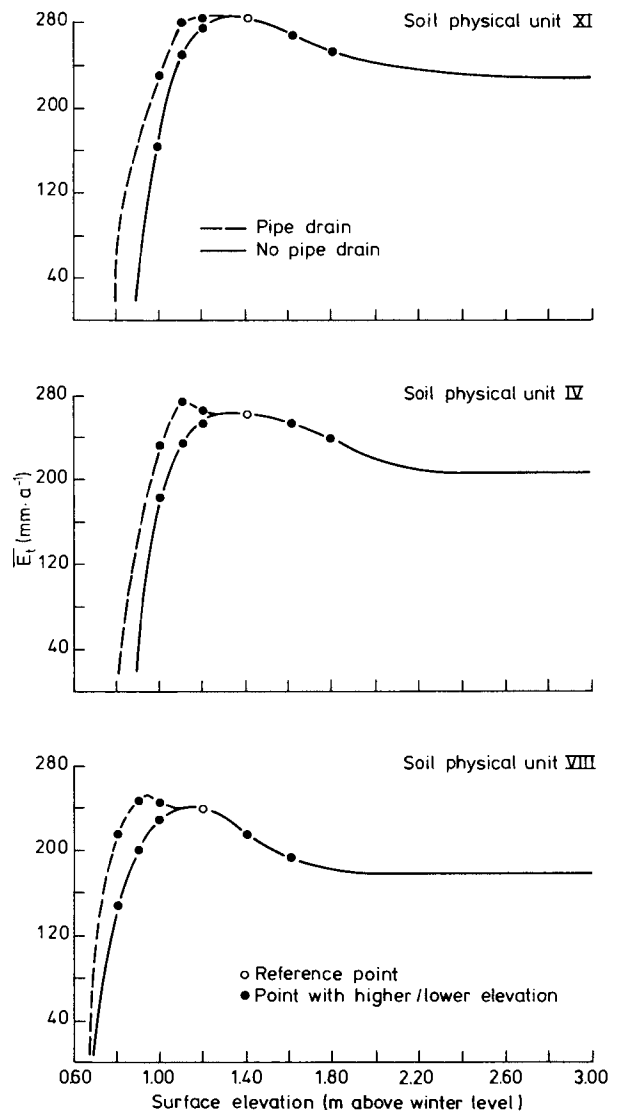

Fig. 10.1. Influence of installing pipe drainage (in places where the soil surface is 0.20 m or more below the level of the soil surface in the reference simulation point) on the relation between level of the soil surface, h_{s2} , and the average yearly transpiration of potatoes, \overline{E}_t , for soil physical units V, VIII and XI with water supply ($s_m = 1.5 \text{ mm}\cdot\text{d}^{-1}$)

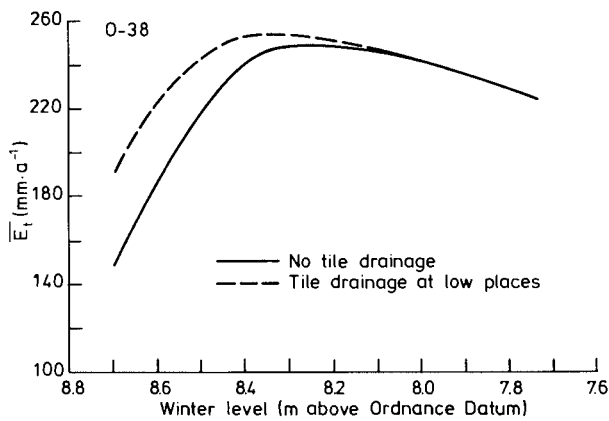

Fig. 10.2. Influence of installation of pipe drainage (in places within a section where the soil surface is 0.20 m or more below the level of the reference point) on the relation between height of the winter level and mean yearly transpiration, averaged over a section, \overline{E}_t , for water supply with $s_m = 1.5 \text{ mm}\cdot\text{d}^{-1}$ in section 0-38

curves for water supply with $s_m = 1.5 \text{ mm}\cdot\text{d}^{-1}$ are shown.

Installation of pipe drainage indeed gives a strong increase of \overline{E}_t in the low-lying places. This is mainly due to a reduction in waterlogging damage, but also to an increase of the effects of water supply.

The curves of Fig. 10.1 were used to establish the relationship between height of winter level and \overline{E}_t , averaged over a section for each surface water management alternative. This has been done for the same five sections used for the establishment of the effect of surface unevenness. The effects of the installation of pipe drainage for section 0-38 are shown in Fig. 10.2 as an example. As can be seen from this figure drainage of the lowest places causes an

increase in \overline{E}_t of the section. The optimum value of the surface water levels shift to a shallower depth (higher level) because the negative effects of higher groundwater tables in low places have been reduced by the pipe drainage. Also the evapotranspiration on higher places increases, resulting in considerably higher \overline{E}_t 's averaged over a section. In Table 10.1 the figures are compared with those of Table 9.5, valid for non-drained conditions.

Pipe drainage in low lying places has on the average a positive effect on \overline{T}_0 of $6.0 \text{ mm}\cdot\text{a}^{-1}$, on \overline{T}_c of $6.2 \text{ mm}\cdot\text{a}^{-1}$ and on $\overline{T}_{1.50}$ of $5.0 \text{ mm}\cdot\text{a}^{-1}$. Compared with the original values $\overline{\Delta T}_c$ slightly increases from 5.6 to $5.8 \text{ mm}\cdot\text{a}^{-1}$, but $\overline{\Delta T}_{1.50}$ clearly decreases from 5.6 to $4.4 \text{ mm}\cdot\text{a}^{-1}$. Installation of pipe drainage in the lowest places causes on the average a shift of about -0.10 m in the optimal values of depth of weir or winter level. So, in case of additional drainage, the surface water levels can be raised.

When by loss of organic matter the soil surface drops and hence relatively higher surface water levels occur, the target levels have to be lowered to keep the surface water level at optimum depth. This adjustment is not necessary when the lowest places are pipe-drained.

10.6. INFLUENCE OF SIZE OF SECTIONS

The influence of unevenness on the effects of water management is considerable (Table 9.6). Therefore it is important to know the variation in soil surface level. An important question is whether it is possible to reduce the variation in surface elevation within a section. In principle this can be achieved in the following ways:

Table 10.1. Optimal depth of weir crest, h_w^* (m below soil surface), or winter level, $h_{o,m}^*$ (m below soil surface), of a section and corresponding mean yearly transpiration, \overline{E}_t ($\text{mm}\cdot\text{a}^{-1}$), averaged over a section, for three alternatives of surface water management and five selected sections without and with pipe drainage at places with a soil surface of 0.20 m or more below the height of the soil surface at the reference point

Section	Weir with a fixed crest at 1.40 m below soil surface				Conservation, winter level 1.40 m below soil surface				Water supply with $s_m = 1.5 \text{ mm}\cdot\text{d}^{-1}$, winter level 1.40 m below soil surface			
	without pipe drainage		with pipe drainage		without pipe drainage		with pipe drainage		without pipe drainage		with pipe drainage	
	h_w^*	\overline{E}_t	h_w^*	\overline{E}_t	$h_{o,m}^*$	\overline{E}_t	$h_{o,m}^*$	\overline{E}_t	$h_{o,m}^*$	\overline{E}_t	$h_{o,m}^*$	\overline{E}_t
W-24	1.50	237	1.40	243	1.60	243	1.50	249	1.65	248	1.55	253
W-26	1.40	239	1.30	245	1.52	244	1.40	250	1.55	250	1.45	255
O-34	1.40	238	1.25	243	1.50	243	1.35	249	1.55	249	1.45	253
O-38	1.35	239	1.25	245	1.50	245	1.40	250	1.52	250	1.45	255
O-42	1.45	225	1.30	232	1.50	231	1.40	239	1.55	237	1.45	243
Mean	1.40	235.6	1.30	241.6	1.52	241.2	1.41	247.4	1.56	246.8	1.46	251.8

- a) leveling of the soil surface. This is very expensive and will never be undertaken just to increase the effects of surface water management. The main reason for land leveling in practice is that low spots within a parcel delay tillage of the whole parcel. Hence, this alternative has not been considered further;
- b) diminishing of the size of sections. In the design of the surface water management plan of 'De Monden' the difference in winter level between adjacent sections is taken about 0.50 m. This criterion was based on local circumstances, such as the already existing drainage system, location of roads, etc. and resulted in 20 sections of about 400 ha each.

To investigate the size of the sections the following procedure has been applied. With the help of the soil map and elevation data, new sections were designed. For each section the average yearly transpiration with conservation and with water supply were determined for different heights of winter level, using the curves given in Fig. 9.8. Next the relations between height of winter level and average yearly transpiration with water supply as given in Fig. 9.9 were derived for each section. The value of \bar{E}_t averaged over a section was compared with the simulated value for the reference point. Plotting the changes in \bar{E}_t found in this way against the size of the section, Fig. 10.3 is obtained. This figure clearly illustrates that enlargement of sections results in a loss of \bar{E}_t . On the basis of such a relationship it would have been possible to optimize the size of sections in 'De Monden' by comparing the benefits with the costs of constructing and operating of

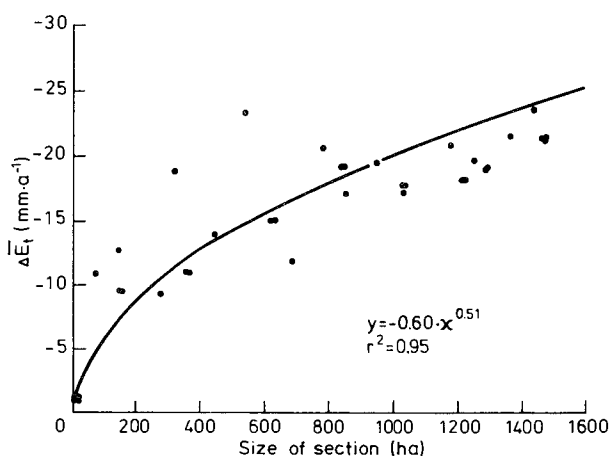

Fig. 10.3. Relation between size of a section and change in mean yearly transpiration, $\Delta\bar{E}_t$, averaged over the section, derived from data on soil type and surface level in the study area 'De Monden'

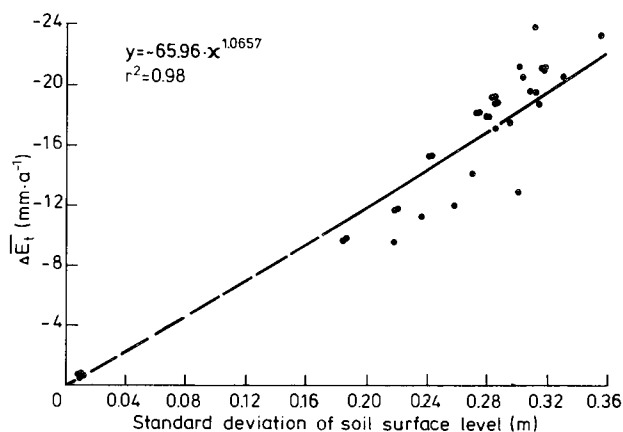

Fig. 10.4. Relation between standard deviation of the soil surface level and change in mean yearly transpiration, $\Delta\bar{E}_t$, derived from data on soil type and surface level in the study area 'De Monden'

weirs and inlet structures. In Chapter 11 this item will be dealt with.

The curve in Fig. 10.3 is only valid for regions with the same unevenness characteristics as the study area. In regions with less microrelief the size of a section can be greater, in sloping regions and in regions having more microrelief the size of sections must be smaller.

To make the results of this study more applicable to other regions, the data used for the construction of Fig. 10.3 have been re-processed to produce a relation between the standard deviation of the soil surface level of a section and loss in \bar{E}_t . The standard deviation has been chosen as a measure for the degree of unevenness. In Fig. 10.4 the result is given. The relation given in this figure is only valid for regions with the same soil types and the same cropping pattern as the study area, but the same procedure can be applied for other soil types and other cropping patterns.

10.7. HYDRAULIC ASPECTS OF SURFACE WATER MANAGEMENT

In this section two subjects will be dealt with. Firstly the influence of surface water management on daily peak discharges and secondly the influence of two ways of handling the weirs, viz. automatic and hand-operated.

Generally it is assumed that water supply does increase the highest discharge rates which in turn may have consequences for the design of watercourses and weirs. To verify this assumption the daily peak discharges, v_{peak} , of each year during 1971-1982 were simulated for the same soil physical-hydrological unit

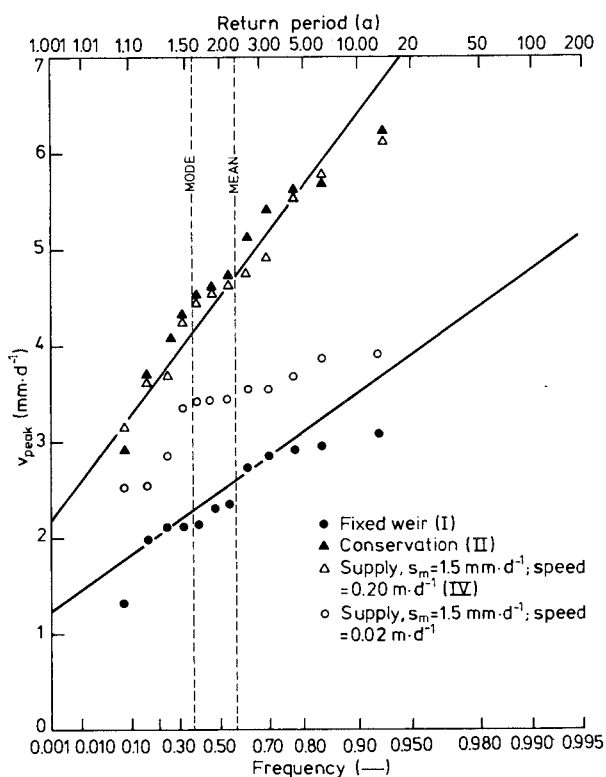

Fig. 10.5. Frequency distribution of daily peak discharges over the weir in the period 1971-1982, simulated with SWAMP for five different ways of surface water management

used in Chapter 7 and the alternatives I (fixed weir crest), II (conservation) and IV (water supply with $s_m = 1.5 \text{ mm}\cdot\text{d}^{-1}$) given in Section 9.1. The three populations of 12 values each were plotted on GUMBEL-paper (Fig. 10.5). The figure shows that with conservation and water supply peak discharges with the same return period are almost doubled, compared with those for a weir with a fixed crest. This doubling is not caused by higher surface water levels during summer, because 11 out of 12 values occur during winter.

Further analysis showed that the differences in peak discharges are caused by the way the weirs are modeled. The weir is supposed to move upward or downward with a maximum speed of $0.10 \text{ m}\cdot\text{d}^{-1}$. With an automatic weir the upstream water level is kept as constant as possible. With a drop or rise speed of $0.10 \text{ m}\cdot\text{d}^{-1}$ water storage in the surface water system is negligible and no attenuation of discharge peaks occurs. With a drop/rise speed of $0.02 \text{ m}\cdot\text{d}^{-1}$ the water level cannot longer be kept constant in all cases. As a consequence storage in the surface water system is possible, resulting in a considerable decrease in daily peak discharges. In case of a fixed weir the surface water level may rise even more when the discharge increases so that the discharge peak is atten-

Table 10.2. Influence of automatization of weirs on yearly transpiration, \overline{E}_t , calculated with SWAMP and averaged over the period 1971-1982, for two specific widths of weir, a_w

	Average yearly transpiration, \overline{E}_t ($\text{mm}\cdot\text{a}^{-1}$)	
	automatic weir	hand-operated weir
$a_w = 0.003 \text{ m}\cdot\text{ha}^{-1}$	281.8	280.0
$a_w = 0.001 \text{ m}\cdot\text{ha}^{-1}$	281.9	279.4

uated, resulting in lower values of daily peak discharges.

In SWAMP the weirs are modeled as if they were automatically adjustable. In practice, however, the automatization of weirs is not self-evident. In principle, it is possible that the operator adjusts the weir by hand when needed according to the operational rules.

In the following the hydrological effects of automatic versus hand-operated weirs will be investigated. The simulated average yearly transpiration of the reference, defined in Chapters 7 and 8, for water supply with maximum capacity of $1.5 \text{ mm}\cdot\text{d}^{-1}$ will be used.

The operation of the hand-operated weir is modeled as follows. Each week the weir is 'visited' and adjusted according to the operational rules. If the actual upstream surface water level differs more than 0.05 m from the target level, the weir level is adjusted with 0.10 m. Even if the difference is more than 0.10 m, the adjustment is never more than 0.10 m to avoid too great fluctuations.

In Table 10.2 the average yearly values of \overline{E}_t for both modes of operation are given. Automatization of weirs does increase \overline{E}_t with $1.8 \text{ mm}\cdot\text{a}^{-1}$ when the specific weir width a_w is $0.003 \text{ m}\cdot\text{ha}^{-1}$. If the specific width is made three times smaller ($a_w = 0.001 \text{ m}\cdot\text{ha}^{-1}$), the difference in \overline{E}_t becomes $2.5 \text{ mm}\cdot\text{a}^{-1}$ in favour of the automatic weir. From the results it can be concluded that automatization of weirs offers only a small advantage.

10.8. SECONDARY EFFECTS

Surface water management has a number of effects which are not incorporated in SWAMP because the necessary knowledge was not available. Effects have also been left out to get a manageable system of models or because the effects are not measurable. A number

of possible effects, termed secondary effects, are listed below. They are:

- a) Decrease in variation in transpiration from year to year, causing a more constant production. For the reference, the simulated reduction in potential transpiration during 1971-1982 has a standard deviation of 41.3 mm (14%) for alternative I (weir crest at 1.40 m below soil surface). For alternative V (water supply with $s_m = 2.50 \text{ mm} \cdot \text{d}^{-1}$) this value is 16.6 mm (6%).
- b) With surface water management the length of the growing season may be prolonged, because higher transpiration means better growing conditions. This effect is especially important for potatoes. In sprinkler irrigation experiments performed during the year 1982, a lengthening of the growing season of sprinkled potatoes of approximately 30 days was found (Van der SCHANS et al., 1984). Although the effect of sub-irrigation will be less pronounced, it can be posed that the ignoracion of this effect in SWAMP underestimates the benefits of water supply.
- c) Decrease of rooting depth. In the soil physical unit used as reference the rooting depth is assumed to be governed by mechanical and chemical properties of the soil layers and not by unfavourable hydrological conditions. With a high groundwater level rooting depth may be limited. In practice it is also possible that roots die after rise of the groundwater table and have a slower regrowth after the groundwater recedes. In SWAMP the thickness of the root zone is fixed and thus is independent of hydrological conditions. The root water uptake indeed reduces under wet conditions, but as soon as the root zone becomes drier, this effect vanishes.
- d) Preservation of peat. Decomposition of organic matter is favoured by good aeration and high temperatures. Low groundwater levels therefore are favourable for a high decomposition rate. Under water conservation and especially under water supply the groundwater levels are considerably higher, resulting in a slower decomposition of organic matter.
- e) Change in frequency of maintenance of watercourses. Larger water depths during summer may hamper the growth of water weeds. On the other hand they must be maintained properly.
- f) The major part of supplied water is used to raise groundwater levels. This extra supply to the groundwater system offers the opportunity to increase water withdrawal from the groundwater system for industries or municipal water supply.
- g) with water supply 'foreign' water is introduced,

with possible negative effects on the quality of the groundwater.

- h) In this study the economical feasibility of sprinkler irrigation from surface water has not been investigated because it is practically not applied in the study region. In other regions sprinkler irrigation from surface water is applied more frequently. If in the near future it also will be applied in the study region, the surface water system, used for sub-irrigation, is also suitable for sprinkler irrigation.
- i) With high surface water levels during summer the growth of grass on part of the side walls of watercourses may be hampered, which may decrease their stability.
- j) From a cultural - historical point of view the small canals in the cut-over peat region should contain water also during the growing season. Besides, these watercourses offer good possibilities for recreation (fishing).

11. ECONOMICAL ANALYSIS OF THE EFFECTS OF SURFACE WATER MANAGEMENT

11.1. INTRODUCTION

The net hydrological effects of water conservation and water supply, given in Table 9.9, are expressed as a percentual increase of the average yearly transpiration, compared with the zero situation. For an economical analysis these effects have to be converted into financial effects i.e. the increase in income of the land users in the area (Section 11.2).

To effectuate this increase, costs have to be made by waterboard, provincial and national water authority. These costs can be divided into investment costs and costs of operation and maintenance, and will be discussed in Section 11.3. Also the economical feasibility of the water conservation and water supply plan for the study area is treated.

In Section 11.4 the internal rate of return of plans for water conservation and water supply will be dealt with.

Effects of surface water management depend on the size of the section, as has been discussed in Chapter 10. Therefore the agricultural benefits of surface water management to the area 'De Monden' can be expressed as a function of number of sections. Also costs of surface water management can be expressed as function of the number of sections. From comparison of both functions an optimal size of sections can be derived as will be shown in Section 11.5.

In case the costs of investments to realize the effects of surface water management in a certain region are not known, it is possible to generate a demand function for water at the inlet point of that region, as will be discussed in Section 11.6.

11.2. INCREASE IN AGRICULTURAL INCOME DUE TO SURFACE WATER MANAGEMENT

In Table 9.9 the average yearly net hydrological effects per unit area of arable land caused by water conservation and water supply have been presented. These data will be converted to the effects on the average yearly income from agricultural products in the region 'De Monden' in three steps, viz. from transpiration to crop yield, from crop yield to benefits per ha and from these to benefits in the area.

a) Conversion of transpiration into crop yields

From molecular diffusion equations for transpiration and photosynthesis the following expression can be derived (FEDDES, 1984):

$$\frac{Y}{E_t} = \frac{A}{\Delta e} \quad (11.1)$$

where Y is dry matter production of a crop ($\text{kg}\cdot\text{ha}^{-1}\cdot\text{d}^{-1}$), A is a proportionality constant ($\text{kg}\cdot\text{ha}^{-1}\cdot\text{mm}^{-1}\cdot\text{mbar}$) and Δe is saturation vapour pressure deficit (mbar). Summing eq. (11.1) over the total number of days of the growing season, the yield Y can be obtained as a function of E_t . This method could not be applied because A is not known. Besides, in SWAMP no data on Δe were used.

Assuming that the maximum yield, Y_{\max} , is reached at potential transpiration, $E_{t,p}$, one can write:

$$\frac{Y_{\max}}{E_{t,p}} = \frac{A'}{\Delta e} \quad (11.2)$$

If A in eq. (11.1) and A' in eq. (11.2) are the same, one arrives at:

$$\frac{Y}{Y_{\max}} = \frac{E_t}{E_{t,p}} \quad (11.3)$$

The use of eq. (11.3) does not include the occurrence of drought sensitive periods.

Eq. (11.3) can only be applied if Y_{\max} is known. However, for the period 1971-1982, used for simulation, no data on Y_{\max} were available.

The most simple expression widely used in the Netherlands is (WERKGROEP LANDBOUWKUNDIGE ASPECTEN VAN GRONDWATERWINNING, 1984):

$$Y_{\max}(n) = E_{t,p}(n) \frac{Y_{\max}}{E_{t,p}} \quad (11.4)$$

where $Y_{\max}(n)$ is maximum yield in year n ($\text{kg}\cdot\text{ha}^{-1}$), $E_{t,p}(n)$ is potential transpiration in year n ($\text{mm}\cdot\text{a}^{-1}$), $\frac{Y_{\max}}{E_{t,p}}$ is average yearly maximum yield ($\text{kg}\cdot\text{ha}^{-1}$) and $E_{t,p}$ is average yearly potential transpiration ($\text{mm}\cdot\text{a}^{-1}$). In eq. (11.4) implicitly a linear relation between transpiration and reduction in yield has been assumed. Taking further that differences in transpira-

tion do not influence the distribution of the dry matter production between harvestable and non-harvestable parts of the crop and ignoring differences in dry matter content in the harvestable parts from year to year, one has:

$$Y_h(n) = \frac{E_t(n)}{\overline{E_{t,p}}} \overline{Y_{h,max}} \quad (11.5)$$

where $Y_h(n)$ is actual harvestable yield in year n (kg marketable product·ha⁻¹), $E_t(n)$ is actual transpiration in year n (mm·a⁻¹) and $\overline{Y_{h,max}}$ is average yearly maximum harvestable yield (kg marketable product·ha⁻¹).

Instead of actual yields and transpiration, which are different from year to year, average actual yields and transpiration can be used, resulting in:

$$\overline{Y_h} = \frac{\overline{E_t}}{\overline{E_{t,p}}} \overline{Y_{h,max}} \quad (11.6)$$

where $\overline{Y_h}$ and $\overline{E_t}$ are average yearly actual yield (kg·ha⁻¹) and transpiration (mm·a⁻¹) respectively.

The quotient $\overline{E_t}/\overline{E_{t,p}}$ is given in Table 9.6. These data are used for sugar beets and winter wheat as well. The reasoning for this is that the actual $\overline{E_t}$ for potatoes may differ from that of the standard crop due to conditions on headlands, along edges of fields etc. and the fact that different varieties of potatoes (early, middle, late) are grown. Further $\overline{E_t}$ for sugar beets and potatoes will not differ much. Winter wheat is harvested somewhat earlier and could have a lower $\overline{E_t}$, but the difference in harvesting time between early potatoes and winter wheat is small. At the end of the growing season transpiration is diminishing due to lower radiation and in addition the part of wheat in the cropping pattern is relatively small. In any case a correction for the real cropping pattern will be very small.

For the maximum yield one can take the yield of an 'ideal' crop growing under optimal conditions of water and nutrient availability and without diseases. In practice, however, this yield never will be obtained. To get actual maximum yields SLOTHOUWER (1982) collected data on average crop yields of all crops cultivated in the study region during the period 1975-1982. From this data the yields in 1978 and 1979 were chosen as representative for the maximum crop yields under practical circumstances because in these years no reduction in transpiration occurred (GREVEN, 1980; HENSUMS, 1980). According to ROZENVELD (1982) the global radiation in 1978 and 1979 was lower than

normal, resulting in a reduction in maximum yield of 3%. Therefore the yields of 1978 and 1979 have to be increased by 3% to arrive at the average yearly maximum crop yields under practical circumstances. For potatoes, sugar beets and winter wheat these data are 45.3 x 10³ kg·ha⁻¹, 49.6 x 10³ kg·ha⁻¹ and 5.7 x 10³ kg·ha⁻¹, respectively.

Taking into account the part of the various crops in the cropping pattern, the hydrological effects now can be converted to effects on yield.

b) Conversion of crop yield into benefits

The effects of surface water management on yields have been converted into benefits per ha using 1980 prices and cropping pattern (SLOTHOUWER, 1982), taking into account the additional costs for harvesting and marketing. An extra yield of 1% resulted in a benefit of Dfl 48.25 per ha arable land.

c) Conversion of benefits per ha into benefits per subregion and benefits for the entire study area

Figures in Table 9.9 give the hydrological effects per unit area including the surface water system. The fractional area of the surface water system is 0.06 and the benefits per ha including the surface water system are therefore 0.94 x Dfl 48.25 = Dfl 45.35. Multiplying the areas per subregion with this figure yields the average yearly increase in agricultural income per subregion. Summing these values gives the benefits for the entire region.

In Table 11.1 the increase in the total agricultural incomes for the subregions and for the whole are 'De Monden' for water conservation and water sup-

Table 11.1. Average annual increase of additional agricultural income (10³ Dfl) due to conservation and water supply, both for normal and restrictive surface water management

	Conservation	Water supply		
		S _m = 0.75	S _m = 1.50	S _m = 2.50
Normal management				
total area	520	318	464	547
subregion west	59	56	74	86
middle	314	135	197	236
east	147	127	193	225
Restrictive management				
total area	311	455	649	765
subregion west	35	78	103	120
middle	188	189	276	330
east	88	178	270	315

ply with three maximum supply capacities are given. Also the figures under more restrictive management are presented.

11.3. COSTS OF SURFACE WATER MANAGEMENT

To make surface water management possible, farmers, waterboard, provincial and national authorities have to invest capital and to make operational and maintenance costs. In the following the costs involved for the different parties will be discussed.

Costs for farmers

Even without water conservation or water supply, the 'wijken' have to be in good maintenance to give adequate drainage. This implies that no additional costs for water management have to be made on farmers level.

Costs for the waterboard

The waterboard 'De Veenmarken' provided data on the necessary investments (SLOTHOUWER, 1982). These data are presented in Table 11.2.

The variable costs at waterboard level are:

- costs of operation of weirs and inlet structures;
- costs of maintenance of these structures;
- costs of maintenance of main canals. This maintenance has to be done anyway, so additional costs are negligible;
- energy costs for pumping water. This applies to section W-22 only; the other sections are supplied by gravity flow from the inlet point.

Costs for the province

To pump the water from Lake IJssel to the inlet point of the waterboard five pumping stations have to

Table 11.2. Total investments and average annual operational costs, both for normal and restrictive surface water management, in 10³ Dfl of water conservation and water supply according to the waterboard 'De Veenmarken', in prices of 1980

	Conser- vation	Water supply		
		s _m = 0.75	s _m = 1.50	s _m = 2.50
Investments	600	691	691	691
Normal management operational costs	9	11	12	12
Restrictive management operational costs	9	11	12	13

Table 11.3. Total investments and average annual operational costs, both for normal and restrictive surface water management, in 10³ Dfl of water supply to the region 'De Monden' to be made by the provincial water authority, in prices of 1980

	Water supply		
	s _m = 0.75	s _m = 1.50	s _m = 2.50
Total investments	1280	2540	4230
Operational costs			
normal management	77	116	131
restrictive management	92	139	157

be installed. The WERKGROEP WATERAANVOER (1983) calculated that the total investments for each pumping station are Dfl 475 000 per m³·s⁻¹ supply capacity. Other investments in the primary system are not required because use is made of existing canals of adequate dimensions. Therefore the investments at provincial level are 5 x Dfl 475 000 = Dfl 2 375 000 per m³·s⁻¹ supply capacity.

The maximum supply capacities are given in mm·d⁻¹. It is assumed that half of the area occupied by infrastructure and buildings is unintentionally receiving water. So, 10% has been added to the amount needed for tilled land and for the surface water system itself. Accounting for this 10%, the maximum supply capacity, s_m (mm·d⁻¹), can be converted into supply capacities, s_r (m³·s⁻¹), by:

$$s_r = s_m \times 5600 \times 1.1/8640 \quad (11.7)$$

The values of s_m of respectively 0.75, 1.5 and 2.5 mm·d⁻¹ correspond then with s_r-values of 0.53, 1.07 and 1.78 m³·s⁻¹ respectively.

The variable costs at provincial level are energy costs for pumping and costs of operation and maintenance. They are Dfl 0.02 and Dfl 0.015 per m³ respectively in 1980 prices. From the hydrological calculations (Table 9.9) the average yearly amount of water to be supplied to the area is known, hence the variable costs to be made at provincial level can be calculated.

Investments and average annual operational costs at provincial level to realize water supply in the area 'De Monden' are summarized in Table 11.3.

Costs at national level

In the framework of the PAWN-study a model has been developed for the operation of the national water supply system (ABRAHAMSE et al., 1982). In this study no costs of investments or variable costs are given. For the time being it has been assumed here

that no costs have to be taken into account to deliver the water at the inlet point(s) of the provincial authority. Because on national level water is scarce in dry summers, in principle some costs should be taken into account (accounting price), but this is left out of consideration.

11.4. INTERNAL RATE OF RETURN OF SURFACE WATER MANAGEMENT

In Tables 11.1, 11.2 and 11.3 eight alternatives of surface water management are distinguished. To investigate whether it is profitable to invest in a particular surface water management plan, one has to discount future benefits and variable costs. This is done via the internal rate of return. That rate, i , is found from:

$$\sum_{n=1}^N \frac{B(n)}{(1+i)^n} - \sum_{n=1}^N \frac{I(n) + C_o(n)}{(1+i)^n} - \frac{R_N}{(1+i)^N} = 0 \quad (11.8)$$

where N is the lifetime of the project (years), $B(n)$ is benefits of the plan in year n (Dfl), $I(n)$ is investments in the plan in year n (Dfl), $C_o(n)$ is operational costs in year n (Dfl) and R_N is rest value of the facilities in year N .

For the surface water management project 'De Monden' the investments were done in 1978 and 1979, while 1979 was the first year with benefits. Taking a time horizon of 30 years and R_N zero, eq. (11.8) becomes:

$$\sum_{n=2}^{30} \frac{B(n) - C_o(n)}{(1+i)^n} - \frac{I_{1978}}{(1+i)} - \frac{I_{1979}}{(1+i)^2} = 0 \quad (11.9)$$

Because of varying weather conditions from year to year $B(n)$ and $C_o(n)$ will vary considerably.

For the internal rate of return it makes quite

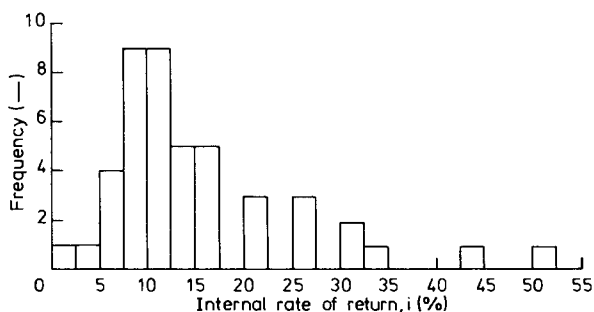

Fig. 11.1. Frequency of the internal rate of return calculated for 46 generated 30 year-long series of benefits

Table 11.4. Internal rates of return (-) of water conservation and conservation plus water supply projects for the region 'De Monden'

	Conser- vation	Water supply		
		$S_m =$ 0.75	$S_m =$ 1.50	$S_m =$ 2.50
Normal management	0.494	0.100	0.089	0.071
Restrictive management	0.352	0.152	0.132	0.104

a difference whether years with higher positive effects occur soon after realization of the project or more towards the end of the time horizon, as can be easily seen from eq. (11.9).

To investigate these stochastic aspects, the following procedure has followed (Van WALSUM and Van BAKEL, 1983). The twelve yearly effects of water supply with a supply capacity of $1.5 \text{ mm} \cdot \text{d}^{-1}$, calculated for the reference for the period 1971-1982, have been considered as a representative sample of the true population. This sample was used to generate 46 series of 30 successive yearly effects. From each series the internal rate of return has been calculated. In Fig. 11.1 the frequency distribution of these calculated internal rates of return is given. As can be seen, the distribution is skewed and its variance is very high. The mean value of the internal rates is 0.156, against a rate for constant hydrological effects of 0.148. This result leads to the conclusion that it is justified to assume $B(n)$ and $C_o(n)$ to be equal to the average yearly benefits and operational costs, given in Tables 11.1, 11.2 and 11.3. Because of technological developments, the physical yields of agricultural crops will increase. On the other hand, the acreage of agricultural land, prices of products and operational costs when corrected for inflation in general will decrease (LOCHT and SLOTHOUWER, 1978). An analysis of these changes is beyond the scope of this study, but it is assumed that they cancel out.

Data from Tables 11.1, 11.2 and 11.3 together with eq. (11.9) give the internal rate of return of the different water management alternatives as shown in Table 11.4. The internal rate of return of conservation is very high, even with a restrictive surface water management. The figures show that the investments in water conservation pay back within two years.

The internal rates of return of water supply are the lower the higher the supply capacity (Fig. 11.2). It should be remarked, however, that the relationship depicted in this figure may not be used to find for a particular choice of internal rate of return the corre-

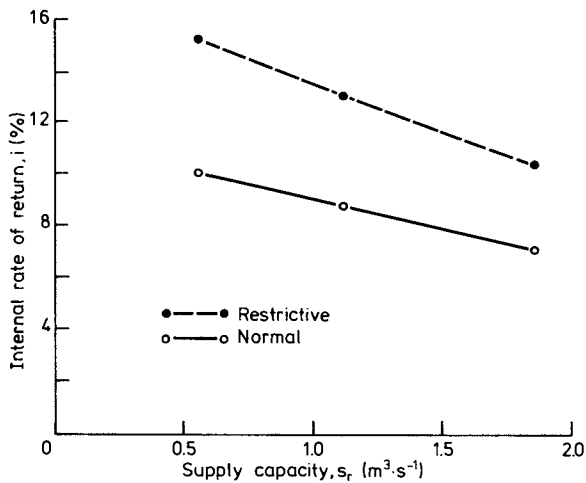

Fig. 11.2. Relationship between supply capacity and internal rate of return of water supply for normal and restrictive surface water management

sponding optimal water supply capacity. This aspect will be treated in the next section.

11.5. SUPPLY CAPACITY, WATER DISTRIBUTION AND SIZE OF SECTIONS BASED ON INTERNAL RATE OF RETURN

Supply capacity

On the basis of data about additional agricultural income, investment costs and operational costs corresponding with the three supply capacities an analytical relationship can be established between supply capacity and additional agricultural income, investments and operational costs, respectively. They can be expressed as follows:

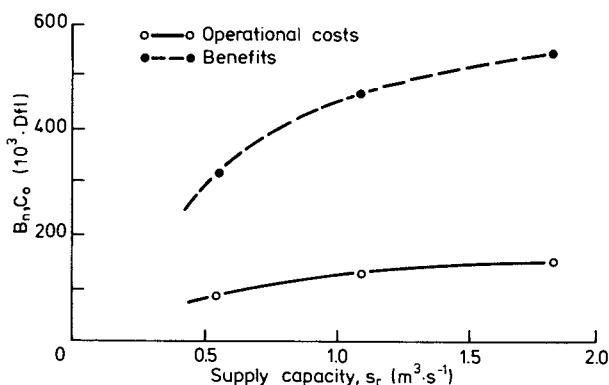

Fig. 11.3. Agricultural benefits, B_n , and operational costs, C_o , of water supply to 'De Monden' as a function of supply capacity for normal surface water management

$$I = 691 + 475 s_r \quad (11.10)$$

$$B_n = -448 + 193 \ln(s_r \times 100); r^2 = 0.997 \quad (11.11)$$

$$B_r = -605 + 266 \ln(s_r \times 100); r^2 = 0.996 \quad (11.12)$$

$$C_{o,n} = -97 + 47 \ln(s_r \times 100); r^2 = 0.971 \quad (11.13)$$

$$C_{o,r} = -117 + 56 \ln(s_r \times 100); r^2 = 0.977 \quad (11.14)$$

where subscripts n and r refer to normal and restrictive surface water management, respectively. As an illustration the relations given in eqs. (11.11) and (11.13) have been given in Fig. 11.3. The derivative of the above relationships with respect to s_r yields the increase in agricultural income, in costs and in investments due to an increase in supply capacity. With the figures obtained in this way the internal rate of return of an increase in supply capacity can be calculated.

The approach described by LOHT (1980), and called the investment steps method, is followed here. The supply capacity is increased in finite steps of $0.1 m^3 \cdot s^{-1}$. For each increment the increase in agricultural income, in investments and in operational costs is calculated with eqs. (11.10) through (11.14). Subsequently the internal rate of return of these increments is calculated, using eq. (11.9).

The results of this procedure for normal and restrictive surface water management are presented in Figs. 11.4 and 11.5. It has been assumed that water supply will always involve a supply capacity, s_r , of at least $0.55 m^3 \cdot s^{-1}$ corresponding with $s_m = 0.75 mm \cdot d^{-1}$.

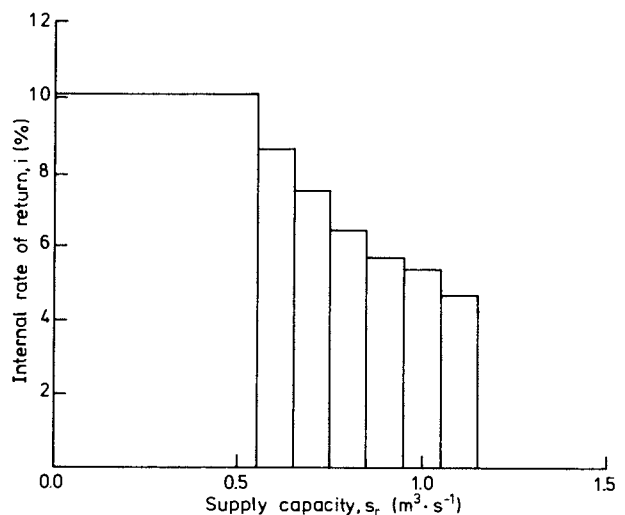

Fig. 11.4. Internal rate of return of increase of supply capacity to the area 'De Monden' of $0.1 m^3 \cdot s^{-1}$ as function of supply capacity for normal surface water management

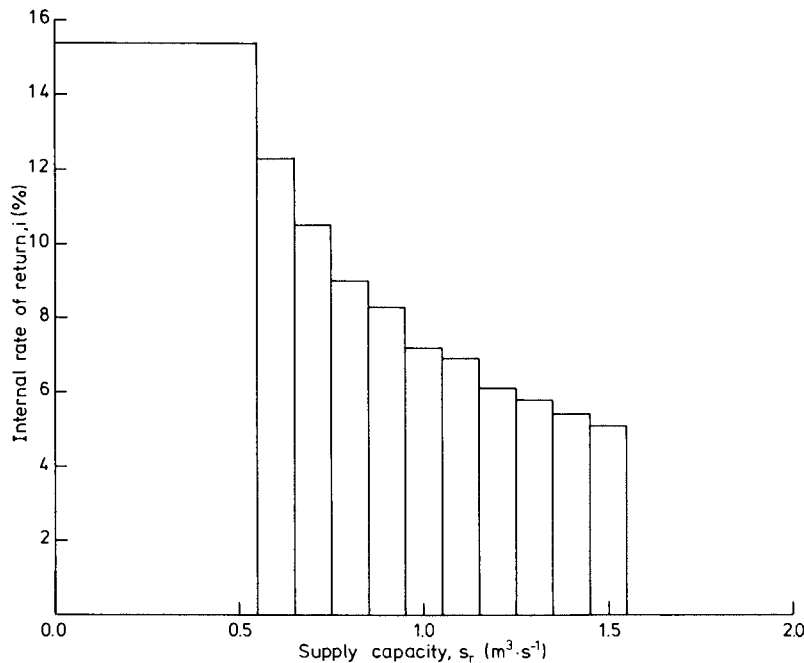

Fig. 11.5. Internal rate of return of increase of supply capacity to the area 'De Monden' of $0.1 m \cdot s^{-1}$ as function of supply capacity for restrictive surface water management

From the figures the supply capacity, s_r , corresponding to a particular internal rate of return, can be determined directly. E.g. if the latter has to be at least 0.10 (a political decision), the supply capacity to be installed has to be restricted to $0.55 m^3 \cdot s^{-1}$ for normal management (Fig. 11.4). On the other hand, for any proposed supply capacity the figures provide the marginal internal rate of return. This return rate is higher for 'restrictive' management.

Comparing Fig. 11.2 with Figs. 11.4 and 11.5, it must be remarked that decisions about the supply capacity have to be based on the marginal internal rates of return (depicted in Figs. 11.4 and 11.5) and not on the internal rates themselves, given in Fig. 11.2.

Optimal water distribution within the area

In the approach given above it has been assumed that the entire area 'De Monden' will get the same supply capacity. However, the hydrological effects show that the western part has a far lower response to water supply than the remainder of the area. Therefore it is expected that by optimizing the distribution of supply capacity between the different subregions a higher internal rate of return can be achieved. To find this out the water supply capacity is increased in small steps of $0.05 m^3 \cdot s^{-1}$. Every time the additional capacity is allocated to the subregion with the highest marginal internal rate of return. This procedure has been worked out for normal surface water management (Fig. 11.6). To compare

the result with the situation without differentiation between the subregions, the latter also is depicted.

With a particular choice of the internal rate of return the corresponding supply capacity now is different from the original one. E.g. if for $i = 0.065$, differentiation decreases the supply capacity from

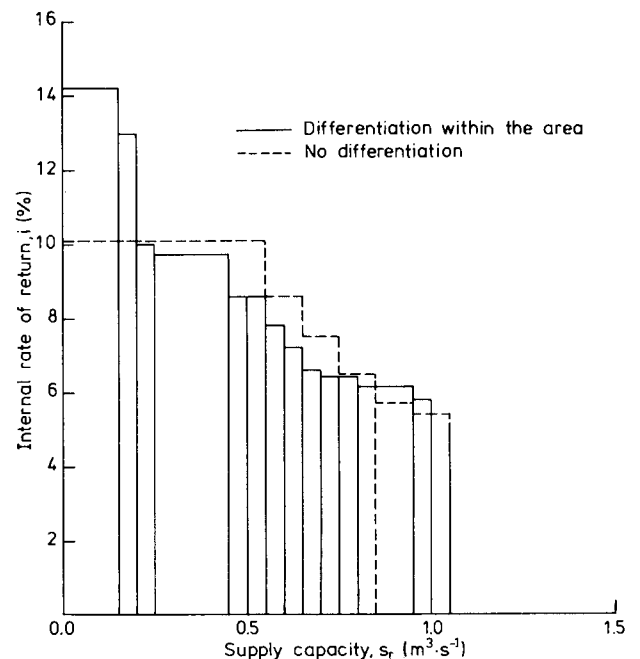

Fig. 11.6. Effect of differentiation of supply capacity between subregions on the relationship between the internal rate of return of an increased supply capacity to the area 'De Monden' for normal surface water management compared with the same relationship without differentiation

0.75 to $0.70 \text{ m}^3 \cdot \text{s}^{-1}$. The distribution of supply capacity to the different subregions is then west $0.0 \text{ m}^3 \cdot \text{s}^{-1}$, middle $0.35 \text{ m}^3 \cdot \text{s}^{-1}$ and east $0.35 \text{ m}^3 \cdot \text{s}^{-1}$. The ratio between agricultural benefits minus operational costs and total investments increases from 0.114 to 0.123.

The practical feasibility of an optimized distribution of water within the area can be questioned, because a waterboard aims at an equal allocation of its services over the water users. However, certain differences could be possible, especially when all persons involved see the advantage of differentiating between areas with different effects.

Optimal size of sections

From Section 10.6 it follows that the hydrological effects of surface water management depend on the size of the sections (see also Fig. 10.3). According to the same procedure described in Section 11.2, the relationship depicted in Fig. 10.3 can be converted to a relationship between size of sections and decrease of agricultural benefits from water supply with $s_m = 1.5 \text{ mm} \cdot \text{d}^{-1}$ for the entire area. The derivative of this relationship expresses the marginal effect of size changes as a function of the size itself. Also the influence on capital investments and operational costs can be expressed as a function of the size of the sections using data given by SLOTHOUWER (1982, 1985). With these relationships the internal rate of return of a decrease of the size of the sections has been calculated; it is depicted in Fig. 11.7. As can be seen from this figure, the section size is about 220 ha when i is taken 10%, which is significantly smaller than actually designed (400 ha). When the relationship depicted in Fig. 10.3 is replaced by a linear one, the relationship in Fig.

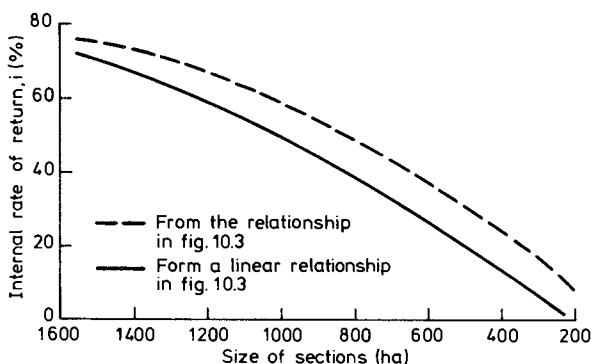

Fig. 11.7. Internal rate of return of decrease of size of sections as function of size of sections, for $s_m = 1.5 \text{ mm} \cdot \text{d}^{-1}$ and normal surface water management for two different relationships between size of sections and change in average transpiration

11.7 also changes. Then the size of the sections for $i = 10\%$ becomes 350 ha. This proves that, apart from the arbitrary choice of $i = 10\%$, the result for the optimal size of sections highly depends on the accuracy of the relation in Fig. 10.3.

11.6. GENERATING A DEMAND FUNCTION FOR WATER

The determination of the internal rate of return of investments for water supply discussed above was only possible because data on the necessary investment in the primary system was available. Usually this will not be the case and then one has to generate a demand function for water for the inlet point of the water supply region. This demand function for water is the relation between amount of water demanded and the price the user is willing to pay. In general, this price will be lower the higher the already existing supply capacity is, because the additional quantities of water will give diminishing returns.

For the generation of demand functions it is necessary to fix an interest rate for the necessary capital investment. In the following the demand functions of the region 'De Monden' will be established at two fixed values for the yearly costs of investments. These yearly costs consist of interest and depreciation. The method of annuities, applied here, calculates the yearly costs as a constant amount during the lifetime of the project. With a particular value for the interest rate and the lifetime of the works as reference for depreciation, the annuity, a , is known. At an interest rate of 0.05 and a time horizon of 30 years the annuity becomes 0.065. With this annuity the demand and supply curves of water will be established. To show the influence of the annuity, also demand curves for $a = 0.10$ have been constructed.

The necessary investments for water supply in the area are given in prices of 1980 in Table 11.2. They are independent of the supply capacity. Consequently the yearly costs for the investments are 0.065 or 0.10 times the investments.

From the figures of Tables 9.6 and 11.1 a relationship between average yearly amount of supplied water, Q_s , and the net increase in agricultural income, B , has been deduced. These relationships

$$B_n = 0.14 Q_s \quad (11.15)$$

$$B_r = 0.16 Q_s \quad (11.16)$$

where B_n and B_r refer to water supply for normal and restrictive management. These relationships indicate

Table 11.5. Average additional agricultural income (10^3 Dfl) and average yearly total costs of water supply (10^3 Dfl) at waterboard level with two values for annuity, a , and three yearly amounts, Q_s (10^3 m³), for both normal and restrictive surface water management

	Q_s	Additional agricultural income	Total costs	
			$a = 0.065$	$a = 0.10$
Normal management	2180	318	56	80
	3420	464	57	81
	4000	547	57	81
Restrictive management	2740	455	56	80
	4120	649	57	81
	4680	765	58	82

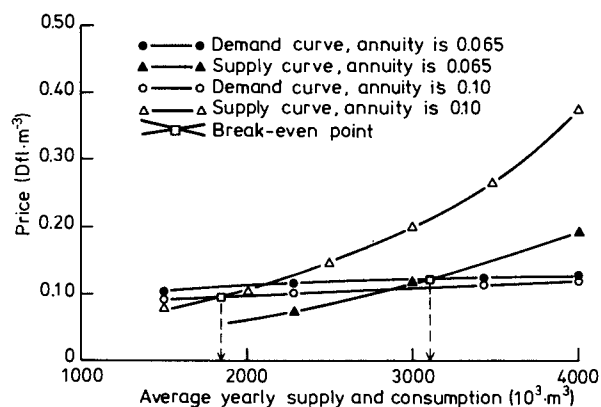

Fig. 11.8. Demand and supply curves for water at the inlet point of the area 'De Monden' for annuities 0.065 and 0.10, and normal surface water management

a marginal productivity of water of Dfl 0.14 per m³ and Dfl 0.16 per m³, respectively. The linearity of these relationships is surprising, because one might expect diminishing returns at higher supply levels. The reason may be that large amounts of water are only applied in dry years, when the efficiency of water supply is high.

At waterboard level the net benefits are the effects after eq. (11.15) or eq. (11.16) minus the investment costs (Dfl 49 000 or Dfl 69 000) and minus the operational costs (Dfl 0.035 per m³). Figures for three different supply levels both for normal and restrictive surface water management are presented in Table 11.5. From these data the waterboard can calculate an accounting price per m³ water. This is the maximum price at which the waterboard would be willing to buy water for from the provincial government. Based on these prices, the demand curves for water to be supplied to the region 'De Monden' have been constructed. They are presented in Fig. 11.8 for normal management and in Fig. 11.9 for restrictive management. For normal management the waterboard would

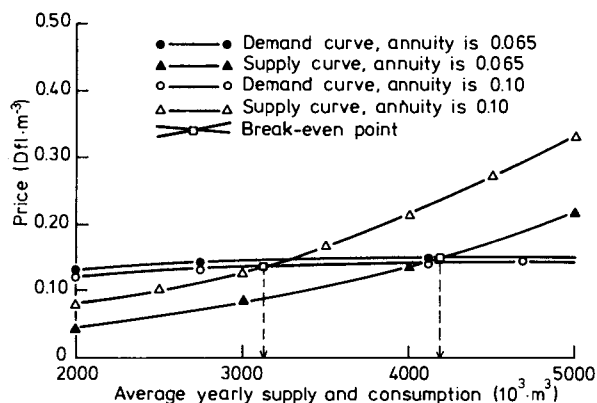

Fig. 11.9. Demand and supply curves for water at the inlet point of the area 'De Monden' for annuities 0.065 and 0.10, and restrictive surface water management

be willing to pay Dfl 0.125 and Dfl 0.10 per m³ respectively for an average yearly supply of 2300×10^3 m³ to the region and Dfl 0.13 and Dfl 0.12 respectively for a supply of 4000×10^3 m³. The demand curves, therefore, give prices which are nearly independent of the quantities involved.

To obtain the average yearly amount of water which actually will be 'bought' from the provincial water authority, one has to know the supply curve of the provincial water authority. As an example, the supply curve for the region 'De Monden' is constructed using the data given in Table 11.3. Again, annuities of 0.065 and 0.10 are assumed (Table 11.6). These data are used to obtain the supply curves of the provincial water authority. These curves are also depicted in Fig. 11.8 and Fig. 11.9. The break-even points are at 3100×10^3 and 1900×10^3 for normal management and at 4200×10^3 and 3100×10^3 for restrictive management. The corresponding prices are Dfl 0.12 and Dfl 0.095 per m³ for normal, and Dfl 0.15 and Dfl 0.135 per m³ for restrictive management.

If the provincial water authority would have a

Table 11.6. Total yearly costs of water supply (10^3 Dfl), at provincial level with two values for annuity, a , and three annual amounts, Q_s (10^3 m³), for both normal and restrictive surface water management

	Q_s	Total costs	
		$a = 0.065$	$a = 0.10$
Normal management	2180	160	205
	3420	281	370
	4000	406	554
Restrictive management	2740	175	220
	4120	304	393
	4680	432	580

demand function for water for all regions within its territory, and the annual costs to realize water supply, it could obtain an optimal distribution of water over the province and generate a demand function of water at its inlet point(s). If all provincial water authorities should apply this procedure the national water authority must be able to make an optimal distribution of water over the entire country and set a price for the water. With this price the provincial water authority in turn can generate supply curves for the inlet points of the waterboards.

SUMMARY AND CONCLUSIONS

With a growing population and the increase of economic activities water of good quality can become scarce, even in a humid country like the Netherlands. This problem calls for proper water resources management at all levels, i.e. national, provincial, waterboard and users level. Because of the interrelationships between the different levels, a systematic approach using techniques developed in Systems Engineering can provide a common basis to arrive at a proper solution. The general concepts of Systems Engineering are shortly described in Chapter 2, together with the application of this approach to surface water management in the Netherlands. From this description follows that especially at waterboard level water resources management nowadays is still performed in a traditional way. However, because of ever growing intensivity of agriculture, demands for nature conservation and increasing groundwater extractions the need for a more fundamental approach of surface water management practices is obvious. To that end a case study was undertaken, the results of which are described in this report.

The study region with an area of approximately 8000 ha, described in Chapter 3, is part of a vast almost completely reclaimed raised bog region at the border of the provinces of Groningen and Drenthe. It covers approximately one third of the area of the waterboard 'De Veenmarken'. The cut-over peat region is mainly used for arable farming.

Geo-hydrological information shows that the basis of the groundwater system is formed by clayey deposits of tertiary age at a depth of about 120 m below soil surface. Above this basis a layer of 40 m of mostly coarse sand forms the lower aquifer. During the Cromerian Interglacial clay and peat was deposited on top of this layer. During the Saalian Glacial an ice-pushed ridge called the 'Hondsrug' has been formed along the western border of the area. The wide and deep valley east of this ridge was later on filled with rather coarse sand forming the middle-deep aquifer of about 25 m. During the Weichselian Glacial a cover sand layer of approximately 15 m thickness was deposited forming the upper or phreatic aquifer. During the Holocene a vast raised bog area east of the 'Hondsrug' was formed.

From the beginning of the 17th century peat was harvested in a systematic way by digging a system of

canals which were used for the shipping of the dried peat. During the peat harvesting, the upper 0.5 m of the peat was left behind because it was not suitable for burning. In reclaiming the area this peat was levelled and covered with sand from the canals. The properly reclaimed land gave good opportunities for agriculture use because the soil profile had a large water holding capacity and rather good drainage conditions because of the presence of ditches and a network of canals that simultaneously could be used for transport purposes. The poor soil fertility was overcome by using city refuse and later on commercial fertilizers.

The arable land use caused a steady decomposition of the peat layer so that the soil surface was lowered, the water holding capacity of the soil decreased gradually and the drainage situation deteriorated. After World War II when mechanization in agriculture and road transport became common in the area, the transport function of the canals vanished and drainage conditions could be improved by maintaining lower open water levels. To improve the water holding capacity of the soil and the vertical water movement, hampered by locally present less permeable layers at the boundary between peat and subsoil, soil improvement (sub-soiling) was carried out on a large scale and is still going on.

Around 1977 the waterboard 'De Veenmarken' set up a new surface water management plan in which water conservation and additional water supply in dry periods were provided for. For this purpose possibilities for manipulating open water levels were realized by constructing a number of weirs and inlet structures. This system present in the study area is described in Chapter 3. Water levels during winter are kept as low as possible, while in spring they are raised to conserve water in the area. By external water supply subsurface irrigation is possible.

The way in which the open water levels are manipulated is based on practical experience. Because weather conditions vary considerably from year to year, the most desired open water levels will do too. A better founded decision about these levels and the time they have to be established can be based on results of field experiments or on model computations. Field experiments are very time consuming and the results only hold for circumstances encountered during the time they are carried out. Therefore hydrological modeling was preferred.

For the study region a model based on physical-mathematical principles was developed. Theoretical backgrounds and parameters necessary to describe the hydrological system of the area are given in Chapter 4. For modeling purposes the hydrological system was subdivided into four subsystems: the atmosphere-crop system, the unsaturated zone, the groundwater system and the surface water system.

In Chapter 5 where the actual modeling is described, special attention is paid to the different possible ways of coupling the distinguished subsystems and the consequences of the different ways of coupling for the final model. The final simulation model called SWAMP (Surface Water Management Program) that contains all distinguished subsystems in a one-dimensional form offers the possibility to compute the effects of surface water level manipulation on groundwater depth and crop transpiration. The regional groundwater flow is incorporated in the lower boundary condition of the unsaturated part. The spatial distribution of this flow over the area is calculated separately with the finite element model for saturated groundwater flow, FEMSATS.

Calibration and verification of both SWAMP and FEMSATS is described in Chapter 6. The calibration of parameters for the saturated groundwater system was restricted to the drainage resistance and the resistance of less permeable layers between the aquifers. The verification of FEMSATS was limited because of the restricted accuracy of available discharge data. A direct verification of the unsaturated flow part in SWAMP was not possible because during the measuring period hardly any reduction in transpiration occurred because of weather conditions. However, verification with thermal infrared images from an InfraRed Line Scanning (IRLS) flight in 1982 showed a good agreement between simulated reductions in transpiration and those obtained from the heat images. Also comparison of the simulation results of SWAMP with the results of the more sophisticated model SWATRE showed a good agreement. The conceptual approach of incorporating regional groundwater flow in SWAMP was verified and proved to be acceptable.

One of the most important objectives of the study was to establish operational rules for manipulating weirs and inlet structures. The empirical approach to arrive at these rules is discussed in Chapter 7. In this approach the most desired surface water level at any time during the growing season is related with groundwater depth and water content of the root zone: the lower the groundwater table or the drier the root zone the higher the surface water level. During winter the surface water level is as low as possible. The

timing of the transition from winter to summer level in spring and from summer to winter level in autumn is also coupled with groundwater depth and water content in the root zone. The actual coupling is established by trial and error.

Chapter 8 deals with the results of a sensitivity analysis of SWAMP. The most sensitive parameters are the soil physical properties, the hydraulic properties of the tertiary surface water system and the parameters for waterlogging damage during the growing season.

Chapter 9 describes the possible effects of water conservation and water supply for the entire study area. To that end the transpiration of a potato crop during the 12 years period 1971-1982 has been simulated with SWAMP for the situations of a fixed weir, water conservation and water supply. These results corrected for crop related and meteorological data, gross-net area, unevenness of soil surface, shape of the phreatic surface and expected changes in soil physical properties, yielded the net effects of water conservation and water supply on transpiration.

In Chapter 10 a number of other aspects of surface water management such as location and number of piezometers needed to manipulate the surface water level, the influence of maintenance of small canals, the consequences of installation of pipe drainage on effects of surface water manipulation are discussed. Also the consequences of automatization and dimensioning of weirs and a number of secondary effects are dealt with.

An economical analysis of the effects of surface water management given in Chapter 11 yields the internal rate of return of investments in plans for water conservation and water supply. By applying the investment steps approach a relationship between internal rate of return of investments and increasing levels of water supply could be determined for the area. With the same approach an optimal allocation of supply capacity within the region and the optimal size of sections was derived. Finally a demand function for water, valid for the study region was generated.

An evaluation of the case study described in this report leads to the following conclusions:

- the most difficult problem in the study was to develop a conceptual modeling approach based on mathematical-physical principles that could lead to a manageable hydrological simulation model;
- much effort was spent to find suitable parameters for the saturated groundwater system. Sensitivity analysis, however, showed that the influence of pa-

parameters pertaining to this subsystem on the final results is less than that of the parameters of the open water and the unsaturated zone;

- assessing of the spatial pattern of drainage resistances proved to be rather problematic, because of the limited accuracy of measured discharges and the determination of surface water levels and groundwater depths representative for a certain area. Better methods for the determination of drainage resistances are therefore urgently needed;
- the weakest point in the modeling was the limited knowledge about parameters for waterlogging damage during the growing season. More fundamental research is necessary;
- thermal infrared images proved to be very useful in verifying the unsaturated part of SWAMP. This technique offers good possibilities for verifying models of the unsaturated zone;
- by carrying out simulations for a sufficient number of soil physical - hydrological units the spatial variability of soil physical properties and drainage resistances could be taken into account in a satisfactory way;
- the operational rules derived from simulations with SWAMP are easily applicable in practice. The only prerequisites are measuring of groundwater depths and setting up a water balance of the root zone;
- the unevenness of the soil surface turned out to be of utmost importance for the final effects of surface water management. The procedure developed in this study to calculate the hydrological consequences of an uneven soil surface can be applied to other drainage and water management problems;
- because of the sensitivity of the results for parameters for waterlogging damage a more restrictive surface water manipulation could be a better solution in practice. Such a strategy, however, reduces the effects of water conservation. This reduction, however, can almost be compensated when water supply is possible;
- pipe drainage systems also used for sub-irrigation drastically increase the potential effects of sub-irrigation. However, the risks of clogging of the drains due to sub-infiltration are not yet clear and as long as this is the case installation of pipe drainage for this purpose cannot be recommended;
- water conservation in the area turned out to be economically very attractive;
- in spite of relatively low average efficiency of water supply for subsurface irrigation (some 10 or 20%) the water supply plan for the area is economical feasible;
- water supply for sub-irrigation is especially effec-

tive in dry years. In such years the effects and efficiencies are about three times the average values. An important result of water supply therefore is that year to year variations in crop yields due to limited water availability are considerably reduced;

- the efficiency of water supply for sprinkling irrigation is (much) higher. However, the economical feasibility of it was not investigated because this was beyond the scope of the study;
- the consequences of surface water management for nature conservation were not incorporated in this study, but because surface water manipulation can be an effective tool in manipulating groundwater levels, it offers good possibilities for nature conservation.

With respect to the application of the results of the study to other regions one has to take into account that the study area is a special one in the way that it has a rather dense and over-dimensioned surface water system. However, the approach followed in the study can be applied to arrive at a better founded way of surface water manipulation in each region having a more or less regular surface water system with an average mutual distance of not more than say 400 m. In cases where the spacing between watercourses is greater one has to apply a more dimensional model to describe the groundwater flow from or to the watercourses. The approach can also be used to carry out feasibility studies on water conservation and water supply projects or to obtain correct design parameters. Applying the developed approach for the purpose of deriving demand functions for water, it can add to an improved water resources management at various decision levels.

SAMENVATTING EN CONCLUSIES

Door toename van de bevolking en de groei van de economische activiteiten kan water een schaars goed worden, zelfs in een regenrijk land als Nederland. Dit probleem vraagt om een goed waterbeheer, niet alleen op nationaal en provinciaal bestuurlijk niveau, maar ook op dat van waterschappen en gebruikers. Vanwege de verwevenheden tussen de verschillende niveaus kan toepassing van technieken ontwikkeld in de 'Systems Engineering' een goed uitgangspunt leveren om tot een goede oplossing van dit beheersvraagstuk te komen. De algemene principes van Systems Engineering en de toepassing van deze benadering op het oppervlaktewaterbeheer in Nederland worden in het kort beschreven in Hoofdstuk 2. Uit deze beschrijving volgt dat vooral op waterschapsniveau het waterbeheer nog steeds op een traditionele manier wordt uitgevoerd, hetgeen inhoudt dat het is gebaseerd op praktijkervaringen en vuistregels. Door de nog steeds toenemende eisen van de landbouw, het sterk groeiende belang van de natuurbescherming en de zich in verschillende gebieden uitbreidende grondwateronttrekkingen wordt het oppervlaktewaterbeheer ingewikkelder en is er behoefte ontstaan aan een meer fundamentele aanpak ervan. In het kader van het onderzoek van het Instituut voor Cultuurtechniek en Waterhuishouding werd daarom besloten tot het uitvoeren van een studie van dit probleem. De uitkomsten van deze studie, die werd uitgevoerd in nauwe samenwerking met het waterschap 'De Veenmarken' en de Landinrichtingsdienst van de provincie Drenthe, zijn in dit rapport beschreven.

Het studiegebied met een oppervlakte van ongeveer 8000 ha staat beschreven in Hoofdstuk 3. Het gebied is deel van het veenkoloniale gebied op de grens van de provincies Groningen en Drenthe en beslaat circa eenderde van het totale gebied van het waterschap 'De Veenmarken'.

Uit de geohydrologische beschrijving volgt dat de basis van het grondwatersysteem wordt gevormd door kleifige afzettingen van tertiaire oorsprong op een diepte van circa 120 m beneden maaiveld. Boven deze basis vormt een circa 40 m dikke laag van overwegend grof zand het onderste watervoerende pakket. Gedurende het Cromerien interglaciale tijdperk werd boven op deze laag klei en veen afgezet. Tijdens de Saalien ijstijd werd een stuwwal, de Hondsrug, gevormd die nu de westelijke begrenzing van het gebied vormt. Het door smeltwater gevormde brede en diepe dal ten oosten

van deze stuwwal werd later opgevuld met tamelijk grof zand. Deze circa 25 m dikke laag vormt het middelste watervoerende pakket. Gedurende de Weichselien ijstijd werd een ongeveer 15 m dik pakket dekzand afgezet dat kan worden aangemerkt als het bovenste of phreatische watervoerende pakket. Gedurende het Holoceen ontstond een uitgestrekt hoogveen ten oosten van de 'Hondsrug'. Vanaf het begin van de 17e eeuw werd dit veen op systematische wijze ontgonnen waarbij een stelsel van grote en kleine kanalen (monden respectievelijk wijken) werd gegraven om de turf af te voeren. Bij het vervenen werd de bovenste 50 cm los veen (bolster) teruggestort. Na de vervening werd het gebied geschikt gemaakt voor de landbouw door de bovenste laag van de bolster te egaliseren en af te dekken met een dunne laag zand afkomstig van de uitgegraven kanalen. Het aldus gecreëerde bodemprofiel was uitermate geschikt voor landbouwkundig gebruik vanwege een groot vochtleverend vermogen, een redelijk goede ontwatering en een goede ontsluiting vanwege de aanwezige kanalen en wijken. In het tekort aan chemische vruchtbaarheid werd aanvankelijk voorzien door het gebruik van stadsafval en later door kunstmest.

Het gebruik als bouwland veroorzaakte een geleidelijke afname van de hoeveelheid veen zodat het maaiveld daalde, het vochtleverend vermogen van de grond verminderde en de drainagesituatie verslechterde. Toen in het begin van de zestiger jaren een overgang plaats vond van vaartransport naar wegtransport konden de peilen in de kanalen worden verlaagd en worden afgestemd op de vanwege de mechanisatie toegenomen landbouwkundige eisen met betrekking tot de ontwatering. Ter verbetering van het vochtleverend vermogen alsmede van de verticale waterbeweging, die werd bemoeilijkt door lokaal aanwezige minder goed doorlatende lagen in het bodemprofiel, werd en wordt op grote schaal bodemverbetering toegepast, voornamelijk in de vorm van mengwoelen.

Omstreeks 1977 ontwierp het waterschap 'De Veenmarken' een nieuw waterbeheersplan waarin ook werd voorzien in wateraanvoer gedurende droge perioden. Om dit plan te kunnen realiseren werd een aantal beweegbare stuwen en inlaatwerken gebouwd. Uitgangspunt van het plan was om het open waterpeil gedurende de winter zo laag mogelijk te houden en in het voorjaar het peil te verhogen om op die manier zo veel mogelijk water in het gebied vast te houden. Bovendien

zou door watertoevoer van buiten het gebied sub-infiltratie mogelijk worden.

Het waterbeheersingssysteem voor het proefgebied staat beschreven in Hoofdstuk 3. De manier waarop het peilbeheer wordt uitgevoerd berust op praktijkervaringen. Omdat de weersomstandigheden van jaar tot jaar sterk kunnen verschillen, varieert het meest gewenste peil eveneens vrij sterk.

Een verantwoorde beslissing omtrent het meest gewenste peil kan worden gebaseerd op resultaten van veldproeven of op modelberekeningen. Het bepalen van effecten van het peilbeheer met veldproeven is niet alleen tijdrovend en duur, maar de uitkomsten zijn alleen geldig voor omstandigheden die tijdens de proefperiode zijn opgetreden, zodat deze proeven zich zouden moeten uitstrekken over een zeer lange tijdsperiode. Daarom werd de voorkeur gegeven aan het berekenen van effecten van peilbeheer door middel van hydrologische modellen. Voor het proefgebied werd een op fysisch-mathematische grondslagen gebaseerd model ontwikkeld. Theoretische achtergronden en gegevens die nodig zijn om het hydrologische systeem van het gebied te beschrijven worden beschreven in Hoofdstuk 4. Ten behoeve van de modellering werd het hydrologisch systeem in vier subsystemen opgedeeld: het atmosfeer-gewas systeem, de onverzadigde zone, het verzadigd grondwatersysteem en het oppervlaktewaterstelsel.

In Hoofdstuk 5, waarin de daadwerkelijke modellering staat beschreven, wordt speciale aandacht besteed aan de verschillende manieren van koppeling van de onderscheiden subsystemen. Het ontwikkelde simulatiemodel SWAMP (Surface Water Management Program) bevat alle subsystemen in een ééndimensionale vorm. Met dit model kunnen de effecten van open waterpeilen op grondwaterstanden en op de grootte van de gewasverdamping worden berekend. De regionale grondwaterstroming is in rekening gebracht via de onderrandvoorwaarden van het onverzadigde subsysteem. Het ruimtelijke patroon van deze stroming, die zich uit in kwel vanuit of wegzijging naar het middelste en diepe watervoerende pakket, wordt apart berekend met het eindige elementenmodel voor verzadigde grondwaterstroming, FEMSATS.

Calibratie en verificatie van zowel SWAMP als FEMSATS worden beschreven in Hoofdstuk 6. De calibratie van parameters voor het verzadigd grondwatersysteem had betrekking op drainageweerstand en de weerstanden van de weerstandbiedende lagen tussen de watervoerende pakketten. Verificatie van FEMSATS was slechts beperkt mogelijk vanwege de onnauwkeurigheid van de beschikbare afvoergegevens. Een directe verificatie van het onverzadigde deel van SWAMP was niet

mogelijk omdat gedurende de meetperiode (1978-1980) nauwelijks of geen reductie in verdamping optrad vanwege de relatief natte weersomstandigheden. Met behulp van warmtebeelden, opgenomen in 1982, konden echter de met het model berekende reducties in gewasverdamping worden vergeleken met uit warmtebeelden afgeleide reducties. Daarbij bleek voor de meeste situaties een goede overeenstemming te bestaan tussen de met de beide methoden verkregen resultaten. Een vergelijking tussen de simulatieresultaten van SWAMP met die van het veel ingewikkelder model SWATRE gaf eveneens goede overeenkomsten te zien.

Ook de conceptuele aanpak om de regionale stroming in rekening te brengen in het model SWAMP werd geverifieerd en bleek acceptabel te zijn.

Een van de belangrijkste doelstellingen van de studie was het opstellen van beheersregels voor stuw en inlaatwerken. De empirische aanpak om deze regels te vinden is beschreven in Hoofdstuk 7. Hierbij wordt het meest gewenste open waterpeil tijdens het groeiseizoen gekoppeld aan grondwaterstand en aan vochtinhoud van de wortelzone. Hierbij geldt als algemene regel: hoe dieper de grondwaterstand of hoe droger de wortelzone des te hoger het oppervlaktewaterpeil. Voorts wordt gedurende de winter het peil zo laag mogelijk gehouden om de ontwateringsmogelijkheden zo goed mogelijk te benutten. Het tijdstip van overgang van winterpeil naar zomerpeil in het voorjaar en van zomerpeil naar winterpeil in de herfst is eveneens gekoppeld aan grondwaterstand en vochtinhoud van de wortelzone. De grenswaarden van grondwaterstand en vochtinhoud waarbij veranderingen in het open waterpeil worden aangebracht, werden door middel van de 'trial and error'-methode verkregen.

Hoofdstuk 8 behandelt de resultaten van de gevoeligheidsanalyse met SWAMP. Het meest gevoelig bleken daarbij de parameters voor de bodemfysische eigenschappen van de onverzadigde zone, voor de hydraulische eigenschappen van het wijkstelsel en voor de wateroverlast gedurende het groeiseizoen.

Hoofdstuk 9 beschrijft de mogelijke effecten van waterconservering en -aanvoer voor het gehele studiegebied. Daarvoor werd de gewasverdamping van een aardappelgewas gedurende de periode 1971-1982 met SWAMP gesimuleerd voor drie verschillende alternatieven, namelijk situaties met vaste stuwen, waterconservering en wateraanvoer. Om een betere benadering van de zich in werkelijkheid voordoende omstandigheden te krijgen moeten de aldus berekende effecten worden gecorrigeerd voor de in werkelijkheid in het gebied geteelde gewassen, voor de meteorologische gegevens gebruikt in de simulatie, voor bruto-netto oppervlakte, voor ongelijkheid van maai-

veldsligging, voor vorm van het phreatisch vlak en voor de in de naaste toekomst te verwachten veranderingen in bodemfysische eigenschappen. Na invoering van deze correcties worden de gemiddelde netto effecten van waterconservering en -aanvoer op de gewasverdamping verkregen. De verdampingswaarden zijn ten behoeve van de economische beschouwing gebruikt voor de berekening van de gewasproductie.

In Hoofdstuk 10 worden een aantal andere aspecten van peilbeheer behandeld. Het betreft de situering en aantal in te richten referentiemeetpunten voor de grondwaterstand, de invloed van wijkonderhoud, de gevolgen van de aanleg van buisdrainage en de automatisering en dimensionering van stuwen. Verder worden een aantal zogenaamde secundaire effecten genoemd die verder in deze studie buiten beschouwing zijn gebleven.

Een economische analyse van de effecten van peilbeheer wordt gegeven in Hoofdstuk 11. Daarbij werd de interne rentevoet van investeringen in plannen voor waterconservering en -aanvoer berekend. Door toepassing van de investeringstrappenmethode kon een verband tussen de interne rentevoet van investeringen in uitbreiding van wateraanvoer en de reeds aanwezige aanvoercapaciteit naar het gebied worden afgeleid. Met dezelfde benadering werden een optimale verdeling van aanvoercapaciteit tussen verschillende deelgebieden en de optimale grootte van peilvakken verkregen. Tenslotte werd een vraagfunctie naar water, geldig voor het proefgebied, gegenereerd.

Een evaluatie van de in dit rapport beschreven case studie leidt tot de volgende conclusies:

- het moeilijkst op te lossen probleem was de ontwikkeling van een conceptuele modelaanpak, gebaseerd op mathematisch-fysische beginselen, die kon leiden tot een hanteerbaar hydrologisch simulatiemodel;
- veel moeite werd besteed om de eigenschappen van het verzadigd grondwatersysteem vast te stellen. Uit de uitgevoerde gevoeligheidsanalyse kon echter worden afgeleid dat de invloed van deze eigenschappen op het uiteindelijke resultaat minder is dan de invloed van eigenschappen van het oppervlaktewaterstelsel en van de onverzadigde zone;
- het vaststellen van de ruimtelijke variabiliteit van drainageweerstanden bleek tamelijk problematisch te zijn vanwege de beperkte nauwkeurigheid van gemeten afvoeren en de vaststelling van open waterpeilen en grondwaterstanden die representatief zijn voor een zeker gebied. Goede methoden voor de vaststelling van drainageweerstanden zijn daarom dringend gewenst;
- het zwakste punt in het modelleringsproces is de be-

perkte kennis omtrent parameters waarmee de gevolgen van wateroverlast op de gewasverdamping in rekening worden gebracht. Meer fundamenteel onderzoek hieromtrent is dan ook gewenst;

- door remote sensing verkregen warmtebeelden bleken zeer geschikt te zijn om het onverzadigde deel van SWAMP te verifiëren. Deze techniek opent goede perspectieven om meer algemeen te worden gebruikt bij verificatie van modellen voor de onverzadigde zone. Dat in plaats van de tot nu toe meestal voor dit doel gebruikte grondwaterstanden;
- door het uitvoeren van berekeningen voor een groot aantal bodemfysisch-hydrologische eenheden kan met de ruimtelijke variabiliteit van bodemfysische eigenschappen, drainageweerstanden en intensiteit van kwel en wegzijging op bevredigende wijze rekening worden gehouden;
- de beheersregels afgeleid uit berekeningen met SWAMP zijn gemakkelijk toepasbaar in de praktijk. De enige voorwaarden voor deze toepassing zijn het hebben van informatie over de zich voordoende grondwaterstanden en het beschikbaar hebben van een waterbalans voor de wortelzone. Eventueel kan het laatste gegeven worden vervangen door directe meting van de vochtinhoud van de wortelzone;
- de ongelijkheid van maaiveldsligging bleek erg belangrijk voor de uiteindelijke effecten van peilbeheer. De in deze studie ontwikkelde procedure om de invloed hiervan te bepalen kan worden toegepast op andere waterbeheersproblemen;
- vanwege de gevoeligheid van de resultaten voor de parameters voor wateroverlast kan een voorzichtiger beheer de voorkeur verdienen. Zo'n beheer beperkt echter de effecten van waterconservering. In het geval wateraanvoer mogelijk is, kan dit verlies vrijwel volledig worden opgeheven;
- aanleg van buisdrainage, die tevens kan worden gebruikt voor infiltratie, doet de mogelijke effecten van peilbeheer sterk toenemen. De risico's van vroegtijdige verstopping van de drains zijn echter nog niet goed bekend. Daarom moet toepassing van buisdrainage voor infiltratie met de nodige voorzorg gebeuren;
- waterconservering in het gebied bleek economisch zeer aantrekkelijk te zijn;
- ondanks een vrij lage gemiddelde efficiëntie van wateraanvoer voor infiltratie (10 à 20%) blijkt wateraanvoer voor het proefgebied redelijk rendabel;
- wateraanvoer voor sub-infiltratie is met name in droge jaren effectief. In dergelijke jaren zijn de effecten en efficiënties ongeveer drie maal zo hoog als gemiddeld. Een belangrijk effect van wateraanvoer is daarom dat de van jaar tot jaar optredende reduc-

- ties in gewasopbrengsten ten gevolge van droogte aanzienlijk worden ~~ver~~minderd;
- de efficiëntie van wateraanvoer voor beregening is (veel) hoger. De hydrologische en economische effecten van beregening zijn echter buiten de studie gehouden;
- de gevolgen van peilbeheer op het hydrologisch regime van natuurterreinen is niet onderzocht, maar omdat peilbeheer zeer effectief kan zijn bij het reguleren van de grondwaterstanden, heeft het goede mogelijkheden voor natuurbeheer.

De in de studie ontwikkelde methoden om te komen tot een beter gefundeerd waterbeheer kan worden toegepast op andere gebieden met een min of meer regelmatig oppervlaktewaterstelsel met een onderlinge afstand tussen de beheersbare waterlopen van niet meer dan ongeveer 400 m. In gebieden waarin deze afstand groter is, dient de grondwaterstroming naar of vanuit het oppervlaktewaterstelsel te worden beschreven met meer-dimensionale modellen.

De ontwikkelde methoden kunnen ook worden gebruikt om de economische haalbaarheid van waterconserverings- en aanvoerplannen vooraf te bepalen of om bepaalde ontwerpcriteria vast te stellen.

Bij toepassing van de methoden om per gebied de vraagfuncties van water te genereren kan deze een bijdrage leveren om te komen tot een beter waterbeheer op verscheidene beslissingsniveaus.

REFERENCES

- ABBOT, M.B., I.R. WARREN, K.H. JENSEN, T. JØNCH-CLAUSEN and K. HAVNØ. 1979. Coupling of unsaturated and saturated zone models. Proc. IAHR-congress, Cagliari: 119-125.
- ABRAHAMSE, A.H., G. BAARSE and E. VAN BEEK. 1982. Policy analysis of water management for the Netherlands. Vol. XIII. Model for regional hydrology, agricultural water demands and damages from drought and salinity. RAND Note N-1500/12-NETH. 315 pp.
- BACHMAT, Y., B. ANDREWS, D. HOLZ and S. SEBASTIAN. 1978. Utilization of numerical groundwater models for water resources management. Ada. 177 pp.
- BAKEL, P.J.T. VAN. 1978. A numerical model for non-stationary saturated groundwater flow in a multi-layered system. Nota 1077 ICW, Wageningen. 47 pp.
- . 1984. Analyse van het stuwpeilbeheer in 1983 zoals uitgevoerd door het waterschap De Veenmarken. Nota 1485 ICW, Wageningen. 26 pp.
- BELMANS, C., J.G. WESSELING and R.A. FEDDES. 1983. Simulation model of a water balance of a cropped soil: SWATRE. J. Hydrol. 63,3/4: 271-286. Techn. Bull. ns 21 ICW, Wageningen.
- BEUVING, J. 1982. Onderzoek naar bodem- en waterhuishoudkundige gegevens voor invoer in en verificatie van een model voor berekening van de effecten van waterhuishouding. Nota 1378 ICW, Wageningen. 28 pp.
- BEVEN, K.J. and P.E. O'CONNEL. 1982. On the role of physically-based distributed modelling in hydrology. Report 81 Institute of Hydrology, Wallingford. 36 pp.
- BLACK, T.A., W.R. GARDNER and G.W. THURTELL. 1969. The prediction of evaporation, drainage and soil water storage for a bare soil. Soil Sci. Soc. Am. Proc. 33: 655-660.
- BLOEMEN, G.W. 1980a. Calculation of hydraulic conductivities of soils from texture and organic matter content. Zeitschr. Pflanzenernähr. Bodenkd. 143,5: 581-605. Techn. Bull. 120 ICW, Wageningen.
- . 1980b. Calculation of steady state capillary rise from the groundwater table in multi-layered soil profiles. Zeitschr. Pflanzenernähr. Bodenkd. 143,6: 701-719. Techn. Bull. 121 ICW, Wageningen.
- BLOEMEN, G.W. 1982. De capillaire eigenschappen van de gronden in het wateraanvoergebied 'De Monden'. Nota 1332 ICW, Wageningen. 33 pp.
- BODEMKAART VAN NEDERLAND, schaal 1:50 000. 1978, 1980. Blad 13 (Winschoten), blad 18 (Ter Apel), blad 23 (Nieuw-Schoonebeek). STIBOKA, Wageningen.
- BOELS, D., J.B.H.M. VAN GILS, G.J. VEERMAN and K.E. WIT. 1978. Theory and system of automatic determination of soil moisture characteristics and unsaturated hydraulic conductivities. Soil Sci. 126,4: 191-199.
- , D.B. DAVIES and A.E. JOHNSTON. 1980a. Soil degradation. Proc. Land use seminar on soil degradation, Wageningen. Balkema, Rotterdam. 280 pp.
- and L. HAVINGA. 1980b. Physical soil degradation in the Netherlands. Nota 1235 ICW, Wageningen. 32 pp.
- BOOY, A.H. 1956. Het Drentse hoogveen, de dalgronden en hun toekomst. Boor en Spade VIII: 56-72.
- , G. RUTTEN and G.P. WIND. 1975. Reconstructiegebied Oost-Groningen en Gronings-Drentse Veenkoloniën en Streekplangebied Oost en Zuid-Oost Drenthe. Onderzoek naar de grondverbetering ten behoeve van de landbouw bij een optimale ontwatering van de gronden. Rapport 1198 STIBOKA, Wageningen. 61 pp.
- BOS, M.G. (ed.). 1976. Discharge measurement structures. Publ. 20 ILRI, Wageningen. 464 pp.
- BOUMA, J. and H.C. VAN HEESSEN. 1979. Waterwingebied 't Klooster: toelichting bij de veldbodemkundige gevoeligheidsanalyse. Basisrapport Commissie Bestudering Waterhuishouding Gelderland. Rapport 1432 STIBOKA, Wageningen. 22 pp.
- BROOKS, P.H. and F. COREY. 1964. Hydraulic properties of porous media. Hydrol. Papers 3. Colorado State Univ., Fort Collins. 27 pp.
- BRUSSEL, P.C.M. 1980. Winderosie en de Veenkoloniën. Nota 1169 ICW, Wageningen. 106 pp.
- CASPARIE, W.A. 1972. Bog development in Southeastern Drenthe (The Netherlands). Thesis, Rijksuniversiteit Groningen. 271 pp.
- CONTACTGROEP GRONDWATERMODELLEN. 1982. Rapport en aanbevelingen van de Contactgroep Grondwatermodellen CHO-TNO. Rapporten en Nota's 10 Committee for Hydrological Research TNO, The Hague. 36 pp.

- DE DONNEA, E.X. 1978. The role and limits of normative models in Water Resources Policy and Management. In: P. Laconte and Y.Y. Haines (eds.). Water resources and land use planning: a systems approach: 7-20. Proc. of NATO Advanced Study Institute, Louvain-la-Neuve.
- DUIN, R.H.A. VAN and C. VAN WIJK. 1965. De verkaveling van de Gronings-Drentse Veenkoloniën. Meded. 88 ICW, Wageningen. 46 pp.
- ERNST, L.F. 1954. Het berekenen van stationaire grondwaterstromingen welke in een verticaal model afgebeeld kunnen worden. Rapport IV Rijkslandbouwproefstation en Bodemkundig Instituut TNO, Groningen. 55 pp.
- 1962. Grondwaterstromingen in de verzadigde zone en hun berekening bij aanwezigheid van horizontale evenwijdige open leidingen. Proefschrift Rijksuniversiteit Utrecht. Pudoc, Wageningen.
- 1976. Second and third degree equations for the determination of the spacing between parallel drainage channels. Nota 896 ICW, Wageningen. 23 pp.
- 1978. Drainage of undulating sandy soils with high groundwater tables. I. A drainage formula based on a constant hydraulic head ratio. II. The variable head ratio. J. Hydrol. 39: 14-50. Techn. Bull. 106 ICW, Wageningen.
- FEDDES, R.A. 1971. Water, heat and crop growth. Thesis, Agricultural University, Wageningen. H. Veenman & Zonen, Wageningen. 184 pp.
- Crop water use and dry matter production: state of the art. Conférence Internationale de la ICID sur les Besoins en eau des Cultures, Paris, 11-14 Sept. 1984 (in press).
- , P.J. KOWALIK and H. ZARADNY. 1978. Simulation of field water use and crop yield. Simulation Monograph. Pudoc, Wageningen. 189 pp.
- FREEZE, R.A. 1971. Three-dimensional, transient, saturated-unsaturated flow in a groundwater basin. Water Resour. Res. 7,2: 347-366.
- GELOK, A.J. 1970. Beschrijving computerprogramma DIWA. Meded. 88 Cultuurtechnische Dienst, Utrecht. 29 pp.
- GILDING, B.H. and J.W. WESSELING. 1983. PREDIS - a physically-based hydrologic response model. In: Proc. 20th Congress Intern. Ass. of Hydr. Res. V: 26-34. IAHR, Moscow.
- GRAAF, M. DE and R.A. FEDDES. 1984. Model SWATRE. Simulatie van de waterbalans van grasland in het Hupselse Beekgebied over de periode 1976 t.m 1982. Nota 1563 ICW, Wageningen. 34 pp.
- GREVEN, S.J. 1980. Weersomstandigheden gedurende het groeiseizoen 1977-1978. In: Jaarverslag 1978 van proefboerderijen te Borgercompagnie, Emmercompascuum en Rolde: 8-12.
- HALL, W.A. and J.A. DRACUP. 1970. Water resources systems engineering. McGraw-Hill Book Company, New York. 372 pp.
- HENSUMS, H. 1980. De weersomstandigheden gedurende het groeiseizoen 1978/1979. In: Jaarverslag 1979 van proefboerderijen te Borgercompagnie, Emmercompascuum en Rolde: 7-10.
- HERINRICHTINGSPROGRAMMA. 1979. Concept-voorontwerp. Herinrichting Oost-Groningen en de Gronings-Drentse Veenkoloniën. 94 pp.
- HOMMA, F. 1981. Metingen ter bepaling van Q/h-relaties voor enkele stuwen in het gebied 'De Monden'. Nota 1266 ICW, Wageningen. 18 pp.
- HOOGHOUJDT, S.B. 1943. De bodemgesteldheid van de Veenkoloniën, doorlatendheid van de watervoevende laag tot maximaal 20 m onder het maaiveld en de daaruit af te leiden algemeene conclusies met betrekking tot de ontwatering van de Veenkoloniën. Bijdrage tot de kennis van eenige natuurkundige grootheden van de grond 8. Verslagen van Landbouwkundige Onderzoekingen 49. The Hague. 193 pp.
- HOOGLAND, J., C. BELMANS and R.A. FEDDES. 1981. Root water uptake model depending on soil water pressure head and maximum extraction rate. Acta Hortic. 119: 123-126.
- HORNUNG, U. and W. MESSING. 1980. A predictor-corrector alternating-direction implicit method for two-dimensional unsteady saturated-unsaturated flow in porous media. J. Hydrol. 47: 317-323.
- KEESMAN, K.J. and P.J.T. VAN BAKEL. 1985a. Gebruikershandleiding van het simulatiemodel voor de waterbalans van een met een gewas begroeid oppervlak gekoppeld aan een peilbeheersingsmodel voor open water: SWADRE (SWATRE-DRENTHE). Nota 1605 ICW, Wageningen. 35 pp.
- , P.J.T. VAN BAKEL, J. KRELING and B.M. HAAYER. 1985b. Berekening van langjarige aanvoereffecten en -efficiënties ten behoeve van de bepaling van de landbouwkundige baten van wateraanvoer naar het 'tussen-10-plan' gebied. Nota 1623 ICW, Wageningen. 118 pp.
- KEULEN, T. VAN. 1982. Bepaling van geohydrologische grootheden uit waterbalansen en grondwaterstanden van het wateraanvoergebied 'De Monden'. Nota 1363 ICW, Wageningen. 38 pp.
- KRAYENHOFF VAN DE LEUR, D.A., F.E. SCHULZE and F. O'DONNELL. 1966. Recent trends in hydrograph synthesis. Proc. of technical meeting. Proc. and Informations 13 Committee for Hydrological Research TNO, The Hague. 103 pp.

- LAAT, P.J.M. DE. 1979. Vochtleverantie-berekeningen. In: J. Bouma (ed.). Overzichtskaarten met betrekking tot een aantal aspecten van de waterhuishouding: rapport 'Bezinningsgroep': 23-28. Rapport 1434 STIBOKA, Wageningen.
- 1980. Model for unsaturated flow above a shallow water-table, applied to a regional subsurface flow problem. Thesis, Agricultural University, Wageningen. Pudoc, Wageningen.
- and R.A. AWATER. 1978. Groundwater flow and evapotranspiration. A simulation model. Part 1. Theory. Basisrapport ten behoeve van de Commissie Bestudering Waterhuishouding Gelderland, Arnhem. 63 pp.
- LANEN, H.A.J. VAN. 1983. Berekening uit het grondwater op hogere gronden en het effect daarvan op lagere gronden. *H₂O* 16,16: 369-375.
- en G.J. HEY. 1978. De tijdsafhankelijkheid van verlagingen als gevolg van grondwaterwinningen nabij Glindhorst (Gelderse Vallei). Meded. 78-4 RID, Rijswijk. 26 pp.
- LEI (Landbouw-Economisch Instituut) and CBS (Centraal Bureau voor de Statistiek). 1980. Landbouwcijfers 1980. LEI, The Hague and CBS, Voorburg. 257 pp.
- LOCHT, L.J. 1980. Berekening van investeringstrappen als middel bij de selectie van cultuurtechnische plannen. *Cultuurt. Tijdschr.* 20,3: 1-9. Meded. ns 1 ICW, Wageningen.
- and D. SLOTHOUWER. 1978 (Postscript 1985). Uitgangspunten voor de evaluatie van plannen in de toekomstige situatie voor het landelijk gebied. Interne notitie ICW, Wageningen. 10 pp.
- MAASS, A., M.M. HUFSCHMIDT, R. DOREFMAN, H.A. THOMAS, S.A. MARGLIN and G.M. FAIR. 1962. Design of water-resource systems. Harvard Univ. Press, Cambridge. 620 pp.
- MENENTI, M. 1982. Physical aspects and determination of evaporation in deserts applying remote sensing techniques. Thesis, Agricultural University, Wageningen. Report 10 ICW, Wageningen. 202 pp.
- MEIJERMAN, G.C. 1966. Betekenis van een aantal cultuurtechnische factoren voor de ontwikkelingsmogelijkheden van veenkoloniale akkerbouwbedrijven. Een toepassing van lineaire programmeringstechnieken. Thesis, Agricultural University, Wageningen. 171 pp.
- MONTEITH, J.L. 1965. Evaporation and environment. *Proc. Symp. Soc. Exp. Biol.* 19: 205-234.
- (ed.). 1975. *Vegetation and the atmosphere. I. Principles.* Acad. Press, London, New York, San Francisco. 278 pp.
- MORTON, F.J. 1978. Estimating evapotranspiration from potential transpiration: practicality of an iconoclastic approach. *J. Hydrol.* 38: 1-32.
- NARASIMHAN, T.N., P.A. WITHERSPOON and A.L. EDWARDS. 1978. Numerical model for saturated-unsaturated flow in deformable porous media. 2. The algorithm. *Water Resour. Res.* 14,2: 255-261.
- NASH, J.E. and J.V. SUTCLIFFE. 1970. River flow forecasting through conceptual models. 1. A discussion of principles. *J. Hydrol.* 10: 282-290.
- NEUMAN, S.P., R.A. FEDDES and E. BRESLER. 1975. Finite element analysis of two-dimensional flow in soils considering water uptake by roots. I. Theory. *Soil Sci. Soc. Amer. Proc.* 39: 224-230.
- NIEUWENHUIS, G.J.A. and C.P. PALLAND. 1982. Verdamping van het aardappelgewas en de meting daarvan via remote sensing. Rapport ns 2 ICW, Wageningen. 68 pp.
- , E.H. SMIDT and H.A.M. THUNNISSEN. 1985. Estimation of regional evapotranspiration of arable crops from thermal infrared images. *Int. J. of Remote Sensing* 6,8: 1319-1334.
- OLSTHOORN, T.N. 1982. Anisotropie, een verwaarloosd verschijnsel bij grondwateraangestroomden. *H₂O* 15,11: 262-267.
- PENMAN, H.L. 1948. Natural evapotranspiration from open water, bare soil and grass. *Proc. Roy. Soc., ser. A*, 193: 120-146.
- PIKJL, M.F., R.L. STREET and I. REMSON. 1974. A numerical model based on coupled one-dimensional Richards and Boussinesq equations. *Water Resour. Res.* 10,2: 295-302.
- POMPER, A.B. 1981. De geohydrologische opbouw van het proefgebied 'De Monden' in het waterschap 'De Veenmarken'. Nota 1316 ICW, Wageningen. 47 pp.
- PRICKETT, T.A. 1975. Modeling techniques for groundwater evaluation. In: *Advances in Hydrosience* 10: 1-143.
- QUERNER, E.P. 1984. Program FEMSAT. 1. Calculation method for steady and unsteady groundwater flow. Nota 1557 ICW, Wageningen. 24 pp.
- and P.J.T. VAN BAKEL. 1985. Description of second level water quantity model including results. Report 37 Project group Southern Peel region. Nota 1586 ICW, Wageningen. 67 pp.
- REFSGAARD, J.C. and E. HANSEN. 1982. An integrated surface/subsurface catchment model. *Proc. Symp. Hydr. Research Basins. Sonderh. Land Hydr., Bern:* 571-581.
- ROZENVELD, T. 1982. 100 ton fabrieksaardappelen per ha. In: *Onderzoek 1982. Stichting Interprovinciaal Onderzoekscentrum voor de Akkerbouw op zand- en veenkoloniale grond in Middenoost- en Noordoost-Nederland:* 15-20.

- RIJTEMA, P.E. 1965. An analysis of actual evapotranspiration. Thesis, Agricultural University, Wageningen. Agric. Res. Rep. 659 Pudoc, Wageningen. 107 pp.
- SCHANS, D.A. VAN DER, M. DE GRAAF and A.J. HELLINGS. 1984. De relatie tussen wateraanvoer, verdamping en produktie, bij het gewas aardappelen. Verslag van een veldproef op het proefterrein Sinderhoeve in 1982. Nota 1539 ICW, Wageningen. 47 pp.
- SCHOTHORST, C.J. and D. HETTINGA. 1983. Grondverbetering: alternatief voor beregening van grasland op lichte zandgrond? *Bedrijfsontwikkeling* 14,2: 115-122. *Cultuurt. Tijdschr.* 22,4: 213-226. Meded. ns 22 ICW, Wageningen.
- SECTORADVIES LANDSCHAPSBOUW VOOR HET DEELGEBIED KANAALSTREEK. 1980. 137 pp.
- SLATYER, R.O. 1967. Plant - water relationships. *Exp. Botany; an intern series of monographs*, vol. II. Acad. Press, London, New York. 366 pp.
- SLOTHOUWER, D. 1982. Economische aspecten van de waterbeheersingswerken in het studiegebied 'De Monden'. Nota 1384 ICW, Wageningen. 70 pp.
- 1985. Evaluatie van de waterbeheersingswerken in het studiegebied 'De Monden' (in press).
- SMIDT, E.H. 1984. Toepassing van het stationaire grondwaterstromingsmodel FEMSATS in 'De Monden'. Nota 1515 ICW, Wageningen. 53 pp.
- SOER, G.J.R. 1977. The TERGRA model: a mathematical model for the simulation of the daily behaviour of crop surface temperature and actual evapotranspiration. Publ. 46 NIWARS, Delft. Nota 1014 ICW, Wageningen. 44 pp.
- 1980. Estimation of regional evapotranspiration and soil moisture conditions using remotely sensed crop surface temperatures. *Remote Sens. Environ.* 9: 27-45. *Techn. Bull.* 116 ICW, Wageningen.
- STAKMAN, W.P., G.A. VALK and G.G. VAN DER HARST. 1969. Determination of soil moisture retention curves. I. Sand-box apparatus. II. Pressure membrane apparatus. 3rd revised ed. ICW, Wageningen.
- TOEBES, G.H. 1975. Systems analysis in environmental engineering and management. Lecture notes. 126 pp.
- VEERMAN, G.J. 1982. Resultaten van fysische bepalingen in grondmonsters afkomstig uit het wateraanvoergebied 'De Monden'. Nota 1331 ICW, Wageningen. 8 pp.
- WALSUM, P.E.V. and P.J.T. VAN BAKEL. 1983. Berekening van de effecten van infiltratie op de gewasverdamping in het herinrichtingsgebied, met een aangepaste versie van het model SWATRE. Nota 1434 ICW, Wageningen. 135 pp.
- WERK GROEP AFVOERBEREKENINGEN. 1979. Richtlijnen voor het berekenen van afwateringsstelsels in landelijke gebieden. 104 pp.
- WERK GROEP GEHYDROLOGISCHE ASPECTEN VAN GRONDWATERWINNING. 1983. Aanbevelingen voor het geohydrologisch onderzoek ter onderbouwing van vergunningsaanvragen voor grondwateronttrekkingen. Commissie Grondwaterwet Waterleidingbedrijven. 35 pp.
- WERK GROEP ICW. 1981. Voortgezet onderzoek kanaal Wadinxveen - Voorburg. Nota 1249 ICW, Wageningen. 205 pp.
- WERK GROEP LANDBOUWKUNDIGE ASPECTEN VAN GRONDWATERWINNING. 1984. Landbouwkundige aspecten van grondwateronttrekking. Berekening van de schade als gevolg van kunstmatige verlaging van de grondwaterstand. Commissie Grondwaterwet Waterleidingbedrijven. 154 pp.
- WERK GROEP OPSCHONEN WILJKEN. 1983. Opschonen wijken. Verslag van een proef in de Drentse Veenkoloniën. 57 pp.
- WERK GROEP WATERAANVOER. 1983. Wateraanvoer naar het herinrichtingsgebied. Herinrichtingscommissie Oost-Groningen en Gronings-Drentse Veenkoloniën, Ter Apel. 147 pp.
- WESSELING, J. 1969. Bergingsfactor en drainagecriterium. Meded. 118 ICW, Wageningen. 8 pp.
- WESTPHAL, R. 1981. Berekening van de ontwerptopafvoer met een gemiddelde frequentie van 1 maal per winterhalfjaar voor het afwateringsgebied van de Eems-Dollardboezem. WWNO-N-800011. Directie Waterhuishouding en Waterbeweging, district Noord, Lelystad.
- WIEBING, R. and G.P. WIND. 1979. Bodemverbeteringsonderzoek in de Veenkoloniën. *Cultuurt. Tijdschr.* 18,6: 1-15. Verspr. Overdr. 246 ICW, Wageningen.
- WIND, G.P. 1979. Grondverbetering, conservering van veen en winderosie in de Veenkoloniën. *Landbouwk. Tijdschr./pt 91,3*: 1-5. Verspr. Overdr. 234 ICW, Wageningen.
- ZEEUW, J.W. DE. 1966. Analyse van het afvoerverloop van gebieden met hoofdzakelijk grondwaterafvoer. Hydrograph analysis of areas with prevailing groundwater discharge. Thesis, Agricultural University, Wageningen. 139 pp.

LIST OF SYMBOLS

Symbol	Definition	Units	Dimension
A	proportionality constant in Eq. (11.1)	$\text{kg}\cdot\text{ha}^{-1}\cdot\text{mm}^{-1}\cdot\text{mbar}^{-1}$	$\text{L}^{-2}\cdot\text{t}^2$
A'	proportionality constant in Eq. (11.2)	$\text{kg}\cdot\text{ha}^{-1}\cdot\text{mm}^{-1}\cdot\text{mbar}^{-1}$	$\text{L}^{-2}\cdot\text{t}^2$
A _S	size of sections	ha	L ²
A _w	wetted area of a watercourse	m ²	L ²
a	annuity	1	-
a _g	fractional area covered by the ground surface	1	-
a _s	fractional area covered by the secondary surface water system	1	-
a _t	fractional area covered by the tertiary surface water system	1	-
a _w	specific width of weir	$\text{m}\cdot\text{ha}^{-1}$	L ⁻¹
a ₁	parameter in linear regression equation	1	-
a ₁ , ..., a ₅	values for W _r /W _{r,s} in $\alpha_T = f(W_r/W_{r,s})$ (Fig. 5.5)	1	-
B	benefits	Dfl	-
B _w	wetted perimeter of a watercourse	m	L
b	effective width of a weir	m	L
b ₁	parameter in linear regression equation	1	-
C	costs	Dfl	-
C _d	discharge coefficient	1	-
C _d '	discharge coefficient in Eq. (4.33)	$\text{m}^{2-n}\cdot\text{d}^{-1}$	$\text{L}^{2-n}\cdot\text{t}^{-1}$
C _M	coefficient in Eq. (5.10)	$10^{-6} \text{m}^{-1}\cdot\text{d}^2$	$\text{L}^{-1}\cdot\text{t}^2$
C _O	operational costs	Dfl	-
C _t	discharge coefficient in Eqs. (5.16) through (5.19)	$10^3 \text{m}^{-3}\cdot\text{d}^{-1}$	$\text{L}^{-3}\cdot\text{t}^{-1}$
C _V	approach velocity coefficient	1	-
c	resistance for vertical flow	d	t
c _d	discharge coefficient in Eq. (5.12)	$10^{-6} \text{m}^{1-n}\cdot\text{d}^{-1}$	$\text{L}^{1-n}\cdot\text{t}^{-1}$
c ₁ , c ₂	constants in Eqs. (4.2) and (4.3)	1	-
D	thickness of an aquifer	m	L
E	evapotranspiration rate	$\text{kg}\cdot\text{m}^{-2}\cdot\text{s}^{-1}$ (mm·d ⁻¹)	$\text{M}\cdot\text{L}^{-2}\cdot\text{t}^{-1}$
E _i	evaporation rate of intercepted precipitation	$\text{kg}\cdot\text{m}^{-2}\cdot\text{s}^{-1}$ (mm·d ⁻¹)	$\text{M}\cdot\text{L}^{-2}\cdot\text{t}^{-1}$
E _O	open water evaporation rate	$\text{kg}\cdot\text{m}^{-2}\cdot\text{s}^{-1}$ (mm·d ⁻¹)	$\text{M}\cdot\text{L}^{-2}\cdot\text{t}^{-1}$
E _p	potential evapotranspiration rate	$\text{kg}\cdot\text{m}^{-2}\cdot\text{s}^{-1}$ (mm·d ⁻¹)	$\text{M}\cdot\text{L}^{-2}\cdot\text{t}^{-1}$
E _S	soil evaporation rate	$\text{kg}\cdot\text{m}^{-2}\cdot\text{s}^{-1}$ (mm·d ⁻¹)	$\text{M}\cdot\text{L}^{-2}\cdot\text{t}^{-1}$
E _{s,p}	potential soil evaporation rate	$\text{kg}\cdot\text{m}^{-2}\cdot\text{s}^{-1}$ (mm·d ⁻¹)	$\text{M}\cdot\text{L}^{-2}\cdot\text{t}^{-1}$
E _t	transpiration rate	$\text{kg}\cdot\text{m}^{-2}\cdot\text{s}^{-1}$ (mm·d ⁻¹)	$\text{M}\cdot\text{L}^{-2}\cdot\text{t}^{-1}$
E _{t,p}	potential transpiration rate	$\text{kg}\cdot\text{m}^{-2}\cdot\text{s}^{-1}$ (mm·d ⁻¹)	$\text{M}\cdot\text{L}^{-2}\cdot\text{t}^{-1}$
E _w	evaporation rate of a wet surface	$\text{kg}\cdot\text{m}^{-2}\cdot\text{s}^{-1}$ (mm·d ⁻¹)	$\text{M}\cdot\text{L}^{-2}\cdot\text{t}^{-1}$
e _a	water vapour pressure at screen height	mbar	$\text{M}\cdot\text{L}^{-1}\cdot\text{t}^{-2}$
e _s	saturation water vapour pressure	mbar	$\text{M}\cdot\text{L}^{-1}\cdot\text{t}^{-2}$
e _w	efficiency of water supply	1	-
F	measured variable	-	-
F'	simulated variable	-	-
f _i	infiltration rate	$\text{mm}\cdot\text{d}^{-1}$	$\text{L}\cdot\text{t}^{-1}$
f _p	maximum possible infiltration rate	$\text{mm}\cdot\text{d}^{-1}$	$\text{L}\cdot\text{t}^{-1}$
f _r	surface runoff	$\text{mm}\cdot\text{d}^{-1}$	$\text{L}\cdot\text{t}^{-1}$

Symbol	Definition	Units	Dimension
G	soil heat flux density	$W \cdot m^{-2}$	$M \cdot t^{-3}$
g	acceleration due to gravity ($g = 9.813$)	$m \cdot s^{-2}$	$M \cdot t^{-2}$
H	sensible heat flux density	$W \cdot m^{-2}$	$M \cdot t^{-3}$
H_e	energy line	m	L
h_a	air entry pressure head	m	L
h_f	height of phreatic surface above datum	m	L
h_f^*	depth of phreatic surface below soil surface	m	L
$h_{f,m}$	height of the phreatic surface midway between the watercourses	m	L
h_l	hydraulic head of lower aquifer	m	L
h_m	hydraulic head of middle aquifer	m	L
h_o	open water level	m	L
$h_{o,c}^*$	depth of bottom of watercourse below soil surface	m	L
$h_{o,m}^*$	target level of surface water relative to soil surface	m	L
$h_{o,s}^*$	depth below soil surface of surface water in secondary system	m	L
$h_{o,t}^*$	depth below soil surface of surface water in tertiary system	m	L
$h_{o,w}^*$	water depth upstream of weir below soil surface	m	L
h_p	pressure head	m	L
h_s	height of soil surface above datum	m	L
h_w^*	depth of weir crest below soil surface	m	L
h_l	upstream head above crest	m	L
I	investments	Df1	-
i	internal rate of return	1	-
K	hydraulic conductivity	$m \cdot d^{-1}$	$L \cdot t^{-1}$
K_M	conveyance factor of Manning	$m^{1/3} \cdot s^{-1}$	$L^{1/3} \cdot t^{-1}$
K_S	saturated hydraulic conductivity	$m \cdot d^{-1}$	$L \cdot t^{-1}$
$K_{x,y,z}$	hydraulic conductivity in x,y,z direction	$m \cdot d^{-1}$	$L \cdot t^{-1}$
L	distance between watercourses	m	L
N	lifetime of project	a	t
n	exponent in Eqs. (4.33) and (5.12)	1	-
n_M	roughness coefficient of Manning	$m^{-1/3} \cdot s^{-1}$	$L^{-1/3} \cdot t^{-1}$
n_S	exponent in Bloemen formula (Eq. 4.19)	1	-
P	gross precipitation	$mm \cdot d^{-1}$	$L \cdot t^{-1}$
P_e	pressure energy	mbar	$M \cdot L^{-1} \cdot t^{-2}$
P_n	net precipitation (gross precipitation - interception)	$mm \cdot d^{-1}$	$L \cdot t^{-1}$
P_a	atmospheric pressure ($p_a = 1013$)	mbar	$M \cdot L^{-1} \cdot t^{-2}$
P_1, \dots, P_4	values for h_p in $\alpha_S = f(h_p)$	m	L
Q	discharge	$m^3 \cdot s^{-1}$	$L^3 \cdot t^{-1}$
Q^*	net radiation flux density	$W \cdot m^{-2}$	$M \cdot t^{-3}$
q	extraction rate of water	$m \cdot d^{-1}$	$L \cdot t^{-1}$
q'	discharge per unit width of weir	$m^2 \cdot s^{-1}$	$L^2 \cdot t^{-1}$
R	hydraulic radius	m	L
R_e	efficiency factor in Eq. (6.1)	1	-
R_N	rest value	Df1	-
r	factor for hysteresis in Eq. (4.19)	1	-
r_a	aerodynamic resistance	$s \cdot m^{-1}$	$L^{-1} \cdot t$
r_c	canopy resistance to vapour transport	$s \cdot m^{-1}$	$L^{-1} \cdot t$
S	sink term/root water uptake	d^{-1}	t^{-1}
S_a	storage coefficient of aquifer	1	-
S_c	fraction of soil covered by crops	1	-

Symbol	Definition	Units	Dimension
S_e	gradient in total energy	1	-
S_f	loss of head per unit length caused by friction resistance	1	-
S_{max}	maximum possible root water uptake	d^{-1}	t^{-1}
S_o	slope of bottom of a watercourse	1	-
S_s	specific storativity	m^{-1}	L^{-1}
s	slope of saturation vapour pressure curve	$mbar \cdot K^{-1}$	$M \cdot L^{-1} \cdot t^{-2} \cdot \theta^{-1}$
s_i	capacity of inlet structure per unit area	$mm \cdot d^{-1}$	$L \cdot t^{-1}$
s_m	supply capacity per unit area	$mm \cdot d^{-1}$	$L \cdot t^{-1}$
s_p	supply capacity of primary system per unit area	$mm \cdot d^{-1}$	$L \cdot t^{-1}$
s_r	supply capacity	$m^3 \cdot s^{-1}$	$L^3 \cdot t^{-1}$
T_a	temperature of the air at screen height	K	θ
$\frac{T_a}{T_c}$	average yearly transpiration simulated for the situation with water conservation	$mm \cdot a^{-1}$	$L \cdot t^{-1}$
$\frac{T_s}{T_s}$	temperature at the water surface	K	θ
$\frac{T_s}{T_s}$	average yearly transpiration simulated for the situation with water supply	$mm \cdot a^{-1}$	$L \cdot t^{-1}$
$\overline{T_0}$	average yearly transpiration simulated for the zero situation (weir with fixed crest)	$mm \cdot a^{-1}$	$L \cdot t^{-1}$
t	time	d	t
t'	time after dry period started (Eq. 5.24)	d	t
v	apparent velocity	$mm \cdot d^{-1}$	$L \cdot t^{-1}$
v_a	flux to aquifer	$mm \cdot d^{-1}$	$L \cdot t^{-1}$
v_b	flux through lower boundary of unsaturated flow model (below lowest possible groundwater table)	$mm \cdot d^{-1}$	$L \cdot t^{-1}$
v_d	flux to watercourses	$mm \cdot d^{-1}$	$L \cdot t^{-1}$
v_f	flux through phreatic surface	$mm \cdot d^{-1}$	$L \cdot t^{-1}$
v_{f1}	fluid velocity	$m \cdot s^{-1}$	$L \cdot t^{-1}$
$v_{o,p}$	supply rate of primary system	$mm \cdot d^{-1}$	$L \cdot t^{-1}$
$v_{o,s}$	flux from secondary to tertiary surface water system	$mm \cdot d^{-1}$	$L \cdot t^{-1}$
$v_{o,w}$	flux over a weir	$mm \cdot d^{-1}$	$L \cdot t^{-1}$
v_{peak}	daily peak discharge	$mm \cdot d^{-1}$	$L \cdot t^{-1}$
v_r	flux through lower boundary of root zone	$mm \cdot d^{-1}$	$L \cdot t^{-1}$
$v_{0.75}$	average yearly amount of water supply with $s_m =$ 0.75, 1.50 and 2.50 $mm \cdot d^{-1}$, respectively	$mm \cdot a^{-1}$	$L \cdot t^{-1}$
$v_{1.50}$			
$v_{2.50}$			
W_r	water storage in the root zone	mm	L
$W_{r,d}$	water deficit in root zone (Eq. 7.1)	mm	L
$W_{r,e}$	water storage in the root zone at equilibrium	mm	L
$W_{r,s}$	water storage in the root zone at complete saturation	mm	L
W_s	water storage in transition zone	mm	L
w_i	specific resistance	d	L
Y	crop yield, dry matter production of a crop	$kg \cdot ha^{-1} (d^{-1})$	$M \cdot L^{-2} (t^{-1})$
Y_h	actual harvestable crop yield	$kg \cdot ha^{-1}$	$M \cdot L^{-2}$
Y_{max}	maximum crop yield	$kg \cdot ha^{-1}$	$M \cdot L^{-2}$
y	water depth in watercourse	m	L
y_c	critical water depth	m	L
z	vertical coordinate	m	L
z_b	height of lower boundary of unsaturated model	m	L
z_o	soil surface	m	L
z_r	rooting depth	m	L

Symbol	Definition	Units	Dimension
α	reaction factor	d^{-1}	t^{-1}
α_S	reduction coefficient for S_{max} (Eq. 8.5)	1	-
α_T	reduction coefficient for $E_{t,p}$ (Eq. 5.25)	1	-
α_V	coefficient depending on velocity distribution in Eq. (4.26)	1	-
α_w	slope of weir	rad	-
γ	psychrometer constant ($\gamma = 0.67$)	$mbar \cdot K^{-1}$	$M \cdot L^{-1} \cdot t^{-2} \cdot \theta^{-1}$
Δe	saturation vapour pressure deficit	mbar	$M \cdot L^{-1} \cdot t^{-2}$
Δh_e	loss of head due to entrance resistance	m	L
Δh_h	loss of head due to horizontal resistance	m	L
Δh_o	backwater effect	m	L
Δh_r	loss of head due to radial resistance	m	L
Δh_v	loss of head due to vertical resistance	m	L
ΔT_C	effect of water conservation on transpiration compared with zero situation	$mm \cdot a^{-1}$	$L \cdot t^{-1}$
ΔT_S	effect of water supply on transpiration compared with conservation	$mm \cdot a^{-1}$	$L \cdot t^{-1}$
$\Delta T_{0.75}$	effect of water supply of 0.75, 1.50 and 2.50 $mm \cdot d^{-1}$, respectively, on transpiration, compared with conservation	$mm \cdot a^{-1}$	$L \cdot t^{-1}$
$\Delta T_{1.50}$			
$\Delta T_{2.50}$			
Δt	length of time step	d	t
ϵ	ratio between molecular weight of water vapour and dry air ($\epsilon = 0.622$)	1	-
θ	soil water content	1	-
θ_a	air content of soil	1	-
θ_s	saturated soil water content	1	-
θ_w	weir notch angle	rad	-
η_f	coefficient for the shape of the phreatic surface	1	-
λ	specific latent heat of vaporization ($\lambda = 2.4518 \times 10^6$)	$J \cdot kg^{-1}$	$L^2 \cdot t^{-2}$
λ_s	soil dependent parameter in Eq. (5.24)	1	-
μ	phreatic storage coefficient	1	-
μ_s	storage coefficient of transition zone	1	-
$\mu_{s,e}$	storage coefficient of transition zone at equilibrium	1	-
ρ_a	density of moist air	$kg \cdot m^{-3}$	$M \cdot L^{-3}$
ρ_s	density of soil	$kg \cdot m^{-3}$	$M \cdot L^{-3}$
ρ_w	density of water	$kg \cdot m^{-3}$	$M \cdot L^{-3}$
τ	time constant	d	t
T	drainage resistance	d	t
T_e	entrance resistance	d	t
T_h	horizontal resistance	d	t
T_r	radial resistance	d	t
T_v	vertical resistance	d	t

APPENDIX: MODEL APPROACH AND OPERATIONAL RULES APPLIED

The hydrological system is divided into four sub-systems: the crop - atmosphere system, the unsaturated zone, the groundwater system and the open water system interrelated through mass flows. The constructed model contains these sub-systems and their interactions. For practical use simplifications have been applied.

In the transient one-dimensional model, of which the computer code is called SWAMP, all sub-systems are taken into account via the fractional area. Simulations are carried out for points representative for a certain area, in our case a section (an area with the same open water level).

The model needs the following data:

A. BOUNDARY CONDITIONS

- the potential transpiration calculated with SWATRE;
- the actual soil evaporation, also calculated with SWATRE (soil evaporation does not change with changing water management);
- the supply capacity per unit area.

B. SYSTEM PARAMETERS

1) Soil physical unit related data consisting of an input file containing:

- equilibrium water storage of the root zone for a number of groundwater depths;
- capillary rise as a function of groundwater depth and of water storage of the root zone;
- storage coefficient of the transition zone below the root zone as a function of groundwater depth and of capillary flux;
- rooting depth;
- parameters for reduction in transpiration (Fig. 5.5).

2) Groundwater flow related data:

- the regional groundwater flow component specified as $v_a = f(h_f^*, h_o^*)$, calculated as the average of all nodal points of a section used in FEMSATS;
- drainage resistance and shape factor determining the local groundwater flow v_d .

3) Open water related data:

- distance between 'wijken';
- geometry parameters for calculating fractional areas and backwater effects;
- roughness parameters;
- weir properties i.e. specific width of weir, adjustment range and speed of weir crest.

C. WATER MANAGEMENT DATA

Type of surface water management, to be specified with a code:

- 0 = surface water level as input (used for verification purposes)
- 1 = weir with a fixed crest (strategy I). Level must be specified as input
- 2 = water conservation i.e. target level is determined by soil water conditions. Target levels are divided into a number of steps ranging from winter level (phase 0) to winter level +0.70 m (phase 7) (strategy II)
- 3 = conservation plus water supply with capacity $0.75 \text{ mm}\cdot\text{d}^{-1}$ (strategy III)
- 4 = ibid 3; capacity $1.50 \text{ mm}\cdot\text{d}^{-1}$ (strategy IV)
- 5 = ibid 3; capacity $2.50 \text{ mm}\cdot\text{d}^{-1}$ (strategy V)

For simulating the effects of water conservation and water supply the operational rules described in run 7 (Table 7.4) are used. They comprise (see also Fig. 7.2):

- from $t = 0$ to $t = t_1$ (20 February) the target level is 1.40 m unless the groundwater depth is below 1.00 m. In that case it becomes 1.20 m;
- from t_1 on the target level is only raised if it is allowed by the groundwater depth. The groundwater depths allowing a certain level are given in Table A.1. For soil physical unit VIII (sand) the target levels are taken 0.20 m higher.

Table A.1. Demands for groundwater depths to allow different target levels

Groundwater depth (m below soil surface)	Target level (m below soil surface)	Phase
>0.85	1.30	1
>0.90	1.20	2
>0.95	1.10	3
>1.00	1.00	4
>1.05	0.90	5
>1.05	0.80	6
>1.05	0.70	7

For the higher phases (5 through 7) an extra safety has been built in in the form of a demand for the water deficit in the root zone (Table A.2).

Table A.2. Demands for water deficits in the root zone to allow different target levels

Water deficit (mm)	Target level (m below soil surface)	Phase
>10	0.90	5
>20	0.80,0.90	6,7

- the earliest time at which water supply is allowed is $t_2 = 120$ (30 April);
- the earliest time at which phases 6 and 7 are allowed is $t_3 = 150$ (29 May);
- the latest time t_4 at which the target level should be lowered is dependable on the water deficit in the root zone according to the rules given in Table A.3.

Table A.3. Dependency of t_4 on the water deficit in the root zone, $W_{r,d}$

Water deficit in root zone, $W_{r,d}$ (mm)	t_4 (day nr.)
<10	220 (8 August)
10-20	$250 - \frac{20 - W_{r,d}}{10} \cdot 30$
>20	250 (7 September)

- the water supply rate depends on the needs but never can exceed the supply capacity;
- target levels are adjusted every week, but cannot exceed 0.20 m in order to prevent too high flow velocities in the watercourses.

SWAMP uses time steps of 1 day, except for the open water system where time steps of 0.01 day are

used. The computing time is approximately 50 sec cpu-time for simulating one year on a VAX-11/750.

Waterboards in the Netherlands try to fulfil agricultural demands by manipulating water levels in open watercourses. This type of water management is mainly based on practical experience. To get a more scientific basis for surface water management a case study was carried out. In this study a model to simulate the effects of manipulating surface water levels was constructed. The model was used to derive operational rules to be used by waterboards.

With the model the additional transpiration by crops caused by water conservation and water supply for subsurface irrigation was simulated. This result was converted into higher agricultural revenues. The corresponding costs were calculated and an economical analysis was performed. This enabled the determination of an optimal supply capacity and of a water demand function for the region.

The proposed model approach can be used by regional water authorities for planning, design and operation of surface water systems.