

Jun 17th, 12:00 AM

## A Toaster For Life: Using Design Fiction To Facilitate Discussion On The Creation Of A Sustainable Internet of Things

Michael Stead  
*Lancaster University*

Follow this and additional works at: <https://dl.designresearchsociety.org/drs-conference-papers>

---

### Citation

Stead, M. (2016) A Toaster For Life: Using Design Fiction To Facilitate Discussion On The Creation Of A Sustainable Internet of Things, in Lloyd, P. and Bohemia, E. (eds.), *Future Focused Thinking - DRS International Conference 2016*, 27 - 30 June, Brighton, United Kingdom. <https://doi.org/10.21606/drs.2016.455>

This Research Paper is brought to you for free and open access by the Conference Proceedings at DRS Digital Library. It has been accepted for inclusion in DRS Biennial Conference Series by an authorized administrator of DRS Digital Library. For more information, please contact [DL@designresearchsociety.org](mailto:DL@designresearchsociety.org).

# A Toaster For Life: Using Design Fiction To Facilitate Discussion On The Creation Of A Sustainable Internet of Things

Michael Stead

Lancaster University  
m.stead1@lancaster.ac.uk  
DOI: 10.21606/drs.2016.455

**Abstract:** This paper presents a design fiction created by the author – the *Toaster For Life*. The design is an initial prototype that seeks to embody Sterling’s concept of *spimes* which when viewed simply, are a class of near future, sustainable, manufactured objects designed to make the *implicit* impacts of a technological product’s entire lifestyle more *explicit* to its potential users. This paper argues that when properly understood, spimes act as a rhetorical device that can be used as a lens through which designers can speculate and reflect upon sustainable technological product futures whilst also critiquing the unsustainable production and consumption practices that define our current lifestyles. To make this case, the paper contextualises the *Toaster For Life* in relation to the spimes concept, the unsustainability of Internet of Things products and sustainable design praxis; and reflects upon the design fiction methodology used to highlight the potential benefits of such an approach.

**Keywords:** spimes; sustainable product design; internet of things; design fiction

## 1. Introduction

The term *spimes* was coined in 2004 by the futurist Bruce Sterling to denote a class of near future, sustainable, manufactured objects. Sterling (2005, p.11) envisions spimes to be “material instantiations of an immaterial system... they are designed on screens, fabricated by digital means and precisely tracked through space and time throughout their earthly sojourn.” In a spime-based future, products, objects and things would be materialised nodes, physical anchors to an expansive, networked digital domain. Taylor & Harrison (2008, p.345) note that the significance of a spime would be “not so much the physical material object [but] the provenance, history” and informational support system that it



This work is licensed under a [Creative Commons Attribution-Non Commercial 4.0 International License](https://creativecommons.org/licenses/by-nc/4.0/).

creates. In essence, a spime object would be “a set of relationships first and always, and an object now and then” (Sterling, 2005, p.77).

Today, electronic product waste (e-waste) is said to be the fastest growing waste stream in the world, while the material resources needed to manufacture such products are becoming ever more scarce (Webster 2015). *Internet of Things* (IoT) products continue to adhere to these unsustainable models of production and consumption, and the time is therefore right to explore Sterling’s concept in greater depth. The origins of spimes are *in the present* as they are likely to develop out of today’s technological product culture. Having done so, their earliest ‘material instantiations’ would share some common attributes with current technological products, for example, location aware (GPS), networked (wireless mobile Internet) and environment sensing (embedded sensors/actuators) capabilities. This has led some to use *spimes* and the *IoT* interchangeably to denote an Internet-connected object. I argue that this is a fundamental misappropriation of Sterling’s term. The informational support afforded by IoT products centres on the ‘use phase’ of their lifecycle – for example, the display of energy usage data – and fails to account for their inherent materiality. In contrast, a spime object would be designed so that it can be managed sustainably by its users throughout its entire lifecycle – from initial design through its use phase to its rebirth as a future spime object ad infinitum.

To frame the spimes concept, Sterling (2005) traces the evolution of what he calls our ‘techno-culture’ – the relationship between people and their material things. His analysis moves from ‘artifacts’ (farmers’ tools) to ‘machines’ (customers’ devices) to ‘products’ (customers’ purchases) to ‘gizmos’ (end-users’ platforms) to beyond, to what he considers a preferable future defined by *spimes*. Sterling asserts that techno-cultures prior to ‘gizmos’ had simpler, more linear sets of relationships. He notes how ‘artifacts’ were self-made or made by those living in close proximity, and enabled people to live off the land. As a result, people were more aware of the provenance of their objects and the effects such tools, and the work they facilitated, had on the immediate environment. This transparency became extremely muddled in the transition to our present day ‘gizmo’ techno-culture due to an overreliance on increasingly complex material extraction, manufacturing, supply chain and consumption infrastructures. Sterling asserts that our relationships with ‘gizmo’ products are highly mediated and *unstable* - we are now *end-users* who are denied the fundamentals of product production and disposal.

I contend that whereas today’s ‘gizmo’ products will eventually be discarded and enter the electronic waste stream with their precious materials and embodied energy forever lost, *spimes, by their very nature, would be an ongoing means rather than an end*. One would know where a spime object has come from, where it is and where it is going. Like Sterling, I posit that this innate transparency would radically alter how people use and value their material things. Thus, while the *present* might be described as a ‘transitory period’ from unsustainable IoT ‘gizmos’ to sustainable spime objects, we are yet to definitively begin designing, manufacturing and consuming the latter. Moreover, as Maly (2012, para.22) stresses, spimes can only come to be if the products “getting manufactured [are] as easy to

dispose of as [they are] to make.” The concept of spimes, then, is both *ideologically of the future* – a manifesto for moving beyond the unsustainable people-product relationships of today – and *pragmatically of the future* – as the physical, infinitely recyclable materials required for spimes’ sustainable existence are yet to exist.

## 2. Spimes As A Lens For Speculation And Reflection

Hales (2013, p.6) describes the concept of spimes as “rhetorically futuristic... a category of imaginary object that is also an intervention in the present and [which] are ‘forward looking’ akin to the actually futuristic objects they create.” As outlined, whilst early spimes may come about through extrapolations and convergences of today’s technologies and creative practices, we are as yet unable to ‘actually’ design and produce spimes. We can, however, use speculative design methods to envision potential near future worlds in which spime objects might exist as well as to explore the types of people-product relationships spimes may possibly facilitate. If Sterling (2005) provided the initiatory theoretical underpinnings for the ‘rhetorically futuristic’ construction of spimes, I contend that the speculative design methodology *design fiction* can, in turn, provide the most appropriate method for envisioning ‘actually futuristic’ spime objects.

Having coined the term spimes, Sterling (2005) also originated the term design fiction and has since defined this method as “the deliberate use of diegetic prototypes to suspend disbelief about change” (cited in Bosch, 2012, para.3). Here he is appropriating Kirby’s (2010) notion of ‘diegetic prototyping’ which denotes how a futuristic object or product might be rendered ‘material’ and fully functional in ‘diegesis’, in other words, as a ‘prop’ embedded in a fictional narrative environment or ‘storyworld’. As Tanenbaum (2011, para.5) states, the positioning of the designed object within a fictional frame is central to the method as it enables designers to “make an argument about a potential future by demonstrating that future in a context that a large public audience can understand.” Design fictions should therefore not be seen as an attempt to predict the future or design a specific ‘product solution’ but as a strategy for opening up inclusive debate about *how* and *why* futures are designed and what they might mean. They aim to create a discursive space in which the design prototype is free of the constraints of normative commercial design practice and can challenge peoples’ insular and habituated perceptions and expectations of the role products and services play in their everyday life (Bleecker 2009).

Unpacking Sterling’s spimes concept, Stead (2015) puts forward seven potential design criteria for near future spime objects:

- Context;
- Technology;
- Sustainability;
- Temporality;
- Metahistory;
- Synchronicity;

- Wrangling.

The *Toaster For Life* is a 'diegetic prototype' which aims to embody three of the above spime design criteria – 'technology', 'sustainability' and 'temporality.' The design (Figure 1) represents an early material instantiation of a spime object; a physical product with innate sustainable attributes including the ability to be repaired, upgraded, customised, recycled and tracked throughout its lifecycle. By presenting a spime as 'actually futuristic' within a fictional world, I hope to provoke audiences to consider the potential implications, meanings and values that spimes may bring and also question whether such a future offers a more 'preferable' alternative to our present day methods of production and consumption. In addition to this, I have also found the conception of the spime-based design fiction to be an inherently reflective process. Sterling (n.d, para.4) also acknowledges this, stressing that, "the best way to understand the many difficulties of design fiction is to attempt to create one." Accordingly, I see spimes as a lens for speculating and reflecting upon alternate worlds in which sustainable technological products exist – both for the audiences that designers seek to their work to engage with and the designers who seek to envision them.

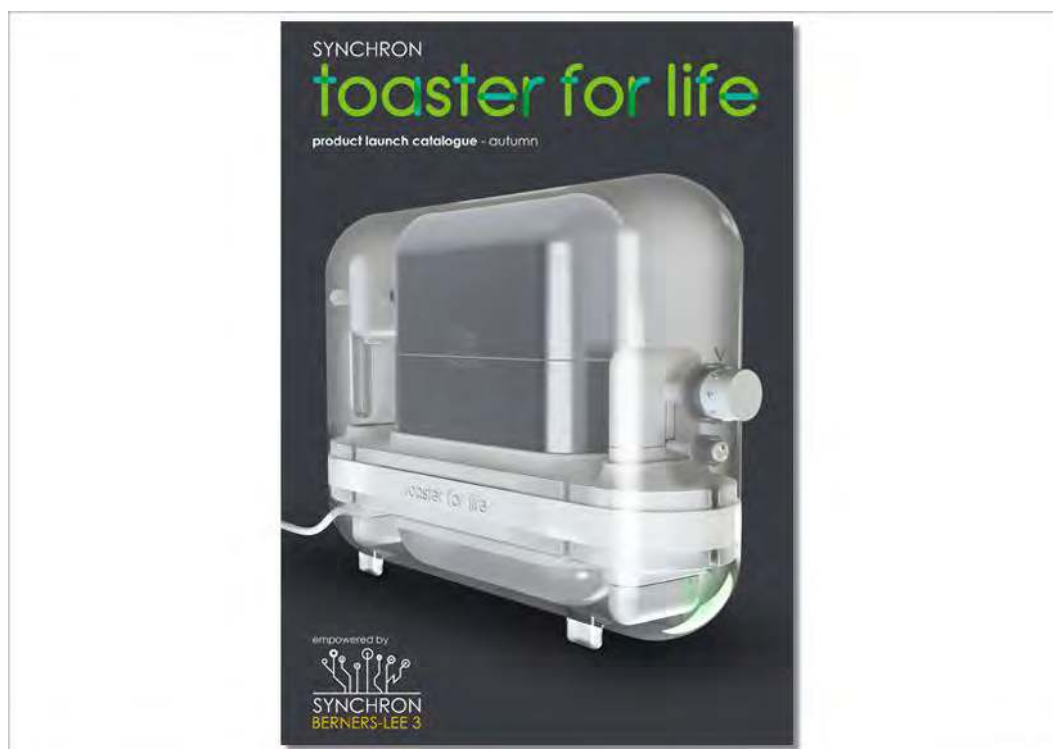

Figure 1 The 'Toaster For Life' represents an early 'material instantiation' of a spime object – a physical product with innate sustainable attributes. I see 'peripheral' material such as this 'product launch brochure' as one way of helping to build a world in which spime objects are 'actually futuristic', in other words, appear as if they 'exist.' Other designers use a variety of media to build speculative worlds including artefacts, films, digital games and text.

### 3. Spimes And Design Fiction

The nascent method design fiction shares similarities with the more established field of *critical design*. Dunne & Raby (2007, para.1) describe the latter as the opposite of 'affirmative' commercial industrial design practice, which simply "reinforces the status quo." Seeing confusion arising from the different terminology, Auger (2013) advocates the use of *speculative design* as an 'umbrella' term for these related envisioning methodologies. Auger's term is useful and allows for easy interchange between the two methods. Nevertheless, I argue that it is design fiction in particular which engenders speculative proposals with characteristics that are key to the envisioning of spimes. Design fiction and spimes are both emblematic of Sterling's (2005, p.5) interest with *time*, encapsulated in his comment: "why things were once as they were, why things are as they are, and what things seem to be becoming." I posit that Sterling introduces the concept of spimes to symbolise this *atemporality* and design fiction as *the* method for concretising it. In this sense, spimes are representative of design fiction and likewise, design fiction is central to the representation of spimes.

#### 3.1 Futures Mundane

Design fiction is often discussed in relation to science fiction literature and film, not least because Sterling is a noted science fiction author but also due to the use of diegetic prototyping, which is rooted in the ways in which new technologies are introduced and 'actualised' within the narratives of Hollywood science fiction films (Kirby 2010). Whilst not seeking to discredit its influence upon the method, I argue that spimes are best framed in relation to mundane, everyday objects as opposed to the fantasy and spectacle often used to present science fiction style technologies. Foster sees the juxtaposition of possible new technological products in relation to past artefacts as an effective way of framing mundane futures:

"We should embrace legacy technologies when conceiving new ones... to show potential disconnects between the new and established, places where technology sticks out like a sore thumb. This is a useful tool for all designers and using it well can help us depict a more tangible future." (Foster, 2013, para.14).

Sterling (2005) begins to do this by describing how a near future spime object might manifest as a bottle of wine. Other design fictions such as the short film *A Digital Tomorrow* (Nova et al, 2012) and those presented in the Bleecker edited *To Be Designed Catalog* (2014) pose similarly mundane near futures. The *Toaster For Life* proposal expands upon this approach by contrasting a near future spime product with a banal and ubiquitous domestic electronic object of today.

Similar to Foster, Auger (2013, p.12) contends that one must ensure "careful management of the speculation; if it strays too far into the future to present implausible concepts... the audience will not relate to the proposal." The *Toaster For Life* design extrapolates a range of present day technologies, practices and behaviours and marries them with fictitious possibilities including domestically 3D printable eco-plastics and 'nano-RFID' tracking

capabilities (Figure 2). This projected convergence would result in new spime-like people-product practices and interactions. In light of this, rather than attempting to design a radical ‘game-changing’ spime product, I have chosen to embody the spime concept in an object that a mainstream audience beyond academia will readily relate to – the humble toaster. I hope that the unfamiliar practices and interactions afforded by a *spime toaster* appear mundane, ‘everyday’ and, most importantly, plausible. This may lessen the potential for the product’s features and technologies to appear fantastical, unreal or as Auger implies – ‘too futured’. Further, the framing of spimes in relation to a mass-produced artefact also facilitates critique of the unsustainability of IoT products. Increasing material scarcity and e-waste are evidence that we often take commonplace objects like toasters for granted. How long will it be before we throwaway more our mundane products and replace them with IoT style devices? Will these connected products be any more sustainable?



*Figure 2 A ‘Synchron nano-RFID tag’ and tags in situ attached to parts. One of several fictional sustainable attributes within the speculation, these tags would be fitted to the majority of the toaster’s parts allowing components to be tracked throughout their lifecycle.*

### **3.2 Sustainability and the Everyday**

The proposal not only seeks to embody a near future spime object but also make the oftentimes abstract concept of electronic product sustainability more practical and tangible to a variety of audiences. The issue of environmental sustainability is often framed within utopian or dystopian narratives. I argue that, rather than engaging audiences, these extreme visions disengage people from taking part in this important dialogue. Accordingly, I have purposely sought to avoid presenting the speculation as an ‘idealistic utopia’ or ‘end is

nigh' style dystopia. Situated in the mundane, the *Toaster For Life* aims to make sustainability more of an 'everyday concern'. This aligns with Sterling's (2005, p.30) view that a design fiction is most successful when it presents new products and technologies as "practical [and] more hands on."

I contend that the use of what Hales (2013) calls 'new media' can also help to bring the sustainability of everyday objects into sharper focus. Whereas art galleries have played a significant role in the dissemination of critical designs, design fictions more actively "encourage debate using social/viral media and popular culture" (MIT MediaLab, n.d, para.2). The appropriation of such media can extend the 'reach' of a design fiction, enabling the proposal to 'speak' to audiences beyond academia, the design sector and artistic elite. Moreover, their playful subversion of marketing material and advertising promo films – the media most associated with 'real' industrial product design – often means that design fictions do not require in-depth *pre-text*. Unlike critical designs whose 'readability' can be undermined by their gallery context and academic framing, audiences are well versed in the *semiology* of design fictions, they can already 'read the signs.' This inherent readability is crucial for the *Toaster For Life* proposal as audiences do not have to negotiate a 'layer of theory', they can instead consider the most significant aspects of the design – its sustainability and how this relates to their day-to-day lives.

#### 4. Crafting The Design Fiction

Alongside the increase in proprietary IoT 'gizmos' such as smart phones, wearable fitness trackers and wireless energy monitors, recent years have also witnessed growth in decentralised IoT practices like the Maker Movement, 'hacking', Fab labs and open hardware and software development. Within these sub-cultures, people use technologies like RFID, computer-aided design software and 3D printers to design and build bespoke Internet-connected objects (McEwen & Cassimally 2013). I contend that it is within this latter strand of technological product development that Sterling identified potential for a more sustainable material culture. The *Toaster For Life* speculation might be seen as a means of reassessing the above technologies and practices to potentially realign them with Sterling's sustainable vision as opposed to the corporate rhetoric of the IoT.

Stead (2015, p.6) posits that the earliest, material instantiations of spimes would likely be characterised by a convergence of the following six technologies and practices:

- 11) RFID tags – Small, inexpensive means of remotely and uniquely identifying a spime object over short ranges;
- 12) GPS – A mechanism to precisely locate a spime object on Earth;
- 13) Internet Search Engine – Search functionality affording a front end to mine the enormous amounts of data that a spime object is constantly collecting and transmitting;
- 14) CAD Software – Tools to digitally construct and manipulate endless iterations of a spime object;



- 15) 3D Printers – Sophisticated, automated and robust means to rapidly fabricate a ‘digital instantiation’ of a spime object into a ‘material instantiation’;
- 16) Eco-materials – Materials which are ecologically safe and durable but also highly versatile. When a spime object is no longer required, they can be cheaply returned into the production process as a raw material for future spime objects.

Yet, if many contemporary unsustainable products are designed and manufactured using the above, how would the lifecycle of an early spime be made potentially more sustainable with similar technologies/practices? Bonnani et al (2009, p.265) suggest that the design of spime objects would rely “on a life-cycle approach... to account for materials and energy over multiple generations. [This] could empower a tinkerer to repair a product; it could offer information about available upgrades and customization; and as technology evolves... could provide new strategies for re-use and recycling.” Figure 1 and Figure 3 show the front cover and an internal page of a ‘product launch brochure’ for the *Toaster For Life* design fiction. In contrast with the toasters of today, the speculative toaster has been designed to allow potential users’ to sustainably manage its lifecycle by partaking in effective product *repair, upgrade, customisation, recycling* and *tracking* practices.

Near future eco-materials would make the material instantiations of spime objects infinitely enhanceable. People would have flexibility to dispose of their material spimes quickly, cultivate longer-lasting relationships with them through care and maintenance, or practice something in-between. Thus, “rather than forever remaining the same... spimes would have the innate ability to transform and reflect changes in technology, cultural trends and peoples’ needs” (Stead, 2015, p.9). With this lineage to past, present and future product cultures, a spime object would be *atemporal*. I therefore chose to title the design *Toaster For Life* as it connotes notions of time. Atemporality is also reflected in the use of the design fiction method itself. The ‘actually futuristic’ spime toaster is ‘materialised’ within a fictional future world and is therefore asynchronous to the present. Despite this theoretical rationale, in my mind *Toaster For Life* does not require specific pre-text. It does much to convey the concept of product longevity and sustainability without academic explanation. As a result, I hope the title will also help the speculation to engage broader, non-academic audiences.

As has already been noted, ‘plausibility’ is the principle reason for representing the spime concept as a toaster. Toasters are a staple of the domestic setting, of routine interactions. In addition to this, the ‘toaster’, like the ‘fridge’, is often cited as an archetypal IoT device, an everyday product that, if made ‘smart’ and networked, would enrich its users’ lives in new and beneficial ways. Sterling (2014, p.19) laments this corporate rhetoric where the connection between the physical material object and the digital world is often being made



*Figure 3 The key spime-like sustainable attributes of the Toaster For Life presented in the speculation – repair, upgrade, customisation, recycling, and tracking. In addition to these features, the prototype has been designed to function like any present day existing toaster, that is, to toast bread.*

for connection's sake – “making your refrigerator talk to your toaster is a senseless trick that any competent hacker can achieve today for twenty bucks.” The *Toaster For Life* seeks to subvert this rhetoric by shifting emphasis away from the production and consumption of superfluous connected gizmos and instead focusing on the responsible and sustainable ownership of ubiquitous electronic objects. In modern western societies, toasters, like many other domestic electronic products, are often seen as disposable. If such a product breaks in some way, it can be more cost effective and convenient to purchase an entirely new product rather than to spend time, energy and money trying to repair the original artefact, either personally or through professional means. Most proprietary electronic objects make use of glues, screws, hidden seals and irreplaceable parts. They are purposely designed to be difficult to maintain and upgrade, forcing people to buy a newer iteration when their current device ceases to function correctly (Slade 2007).

The *Toaster For Life* should not be seen as a potential ‘solution product’ to the unsustainable issues described above, but as a means for generating discussion about those issues.

Bleecker outlines this distinction:

“Design fiction objects are totems through which a larger story can be told, or imagined or expressed. They are like artifacts from someplace else, telling stories about other worlds.” (Bleecker, 2009, p.7).

Nevertheless, I argue that in order for the world in which the *Toaster For Life* exists to appear plausible and engage audiences effectively, the 'design fiction object' itself must also *appear* plausible, that is, *seem as if it had actually been designed and could be manufactured*. With this in mind, the process of designing the spime toaster was more intricate and time-consuming than I had first anticipated. What appears to be a relatively simple and banal object grows increasingly complex when one begins to consider integrating several sustainable strategies into its design. Furthermore, uncertainties arise when designing for a combination of materials and technologies that presently do not exist. These issues also impacted the adoption of Stead's (2015) spime design criteria. Rather than including all seven in this first speculation, I made the decision to focus on the design potential of only three of the criteria – 'technology', 'sustainability' and 'temporality'. I felt that this combination would 'do enough' to convey the sustainable credentials of an early material spime object without losing the essence of Sterling's concept.

I began the design process by gaining a greater understanding of the design, manufacture and provenance of an existing toaster (Figure 4). As a result of this analysis, I considered using the purchased product as the template for the speculative iteration (Figure 4 – right) depicts my initial CAD model. I soon realised, however, that in order to accommodate various spime-like attributes, I would have to rethink the design in a more holistic manner. As illustrated by Figure 5, several different iterations of the prototype thus followed. The ensuing *Toaster For Life* prototype has been designed to toast bread (Figure 3), but unlike other toasters, it would also afford self-repair and upgrades due to its modular design (Figure 6). Using sustainable design strategies *Design-for-Disassembly* (Chiodo 2005) and *Design-for-Recycling* (Gaustad, et al 2010) as reference, I have integrated accessible parts and efficient component separation into the toaster's design in an attempt to allow more effective repair and recycling by potential users. No glues, screws or hidden seals are featured. Modularisation is said to extend product lifecycles and reduce use of materials, energy, packaging and distribution emissions (Greenpeace 2014). Upgrades to inner componentry would also be possible because the design would operate via modular open source hardware and software (Figure 7). It is common for electronic components to be soldered directly to printed circuit boards making them immovable without the correct equipment and expertise (this is the case with the purchased toaster). The *Toaster For Life* design incorporates solderless breadboards allowing components to be simply exchanged if they break and/or upgraded should new functionality become available.

Modularisation and open source technologies like *Arduino* are seen as tenets of democratised and decentralised 'making' and 'hacking' cultures. Indeed, such techniques are central to Make Magazine's influential *Owner's Manifesto* (Torrone 2006). In recent years, modularization has been subject to increased interest within the mobile phone sector where manufacturers have been heavily criticised for perpetuating planned obsolescence. While the highly publicised *Google Project Ara* phone and independent projects *PhoneBlocs* and *PuzzlePhone* remain in the development stages, responsible manufacturer *Fairphone* has brought two modular smart phones to market. Each of these four projects is pictured in

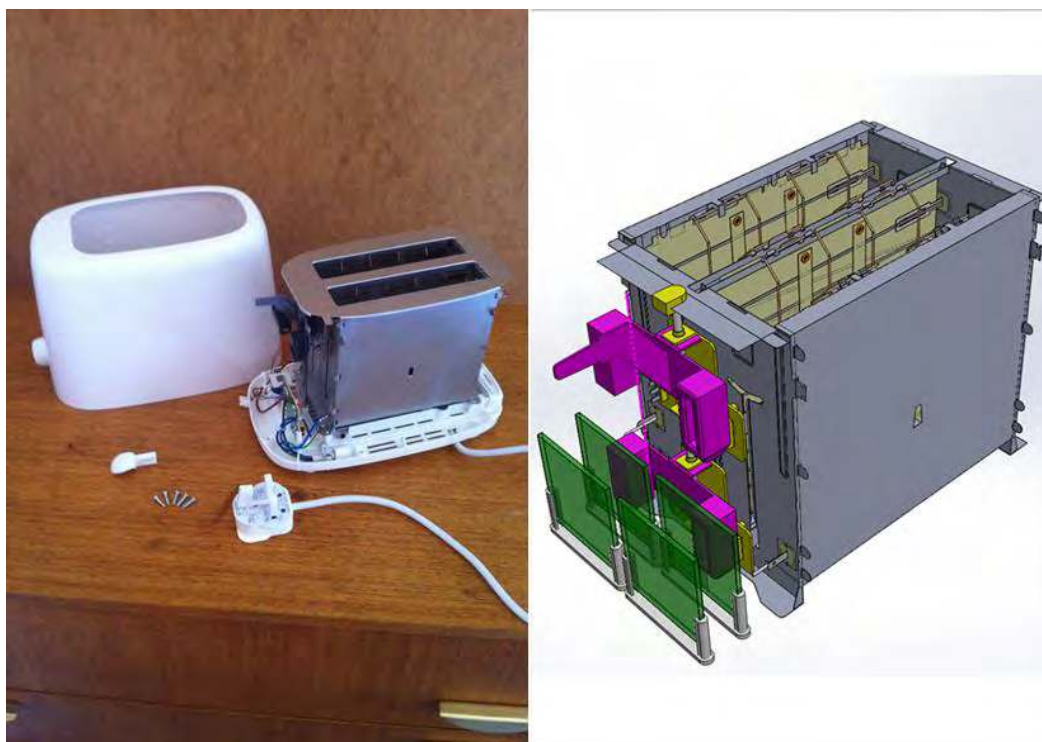

Figure 4 Left – The existing toaster that I purchased and deconstructed; right – my initial CAD model based on the purchased toaster.

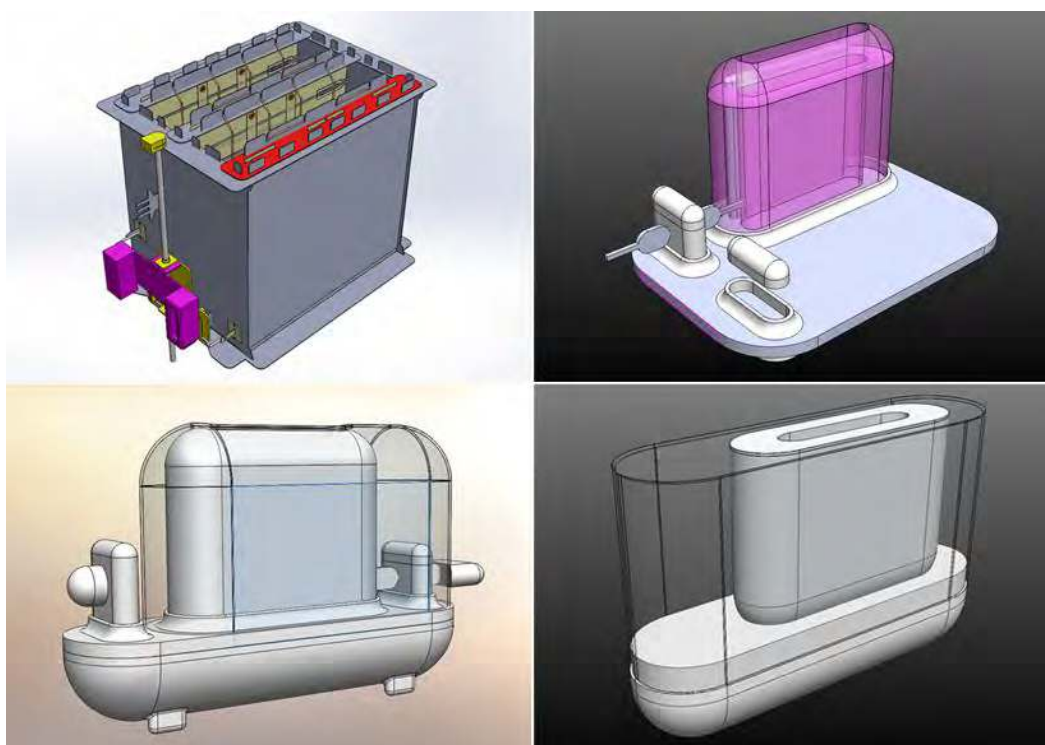

Figure 5 Successive iterations of the Toaster For Life prototype.



Figure 6 The prototype's design is modular with no screws, glues or hidden seals. Users would therefore be able to easily disassemble the toaster.



Figure 7 The design would operate via modular open source hardware and software. Here the solderless breadboard allows easy replacement/repair of componentry should any parts break. The 'Berners-Lee 3' micro-processor board's wireless and geo-locative functions enable the product and its parts to be tracked.



Figure 8 A range of modular smart phone concepts. Clockwise top left to bottom left – Fairphone, Google’s Project Ara, PhoneBlok and PuzzlePhone (all 2015).

Figure 8. In the main however, open source and modular approaches are yet to be adopted into the design of most mass-produced proprietary consumer electronic appliances, despite growing calls to do so from ethical organisations such as Restart (2015) and the Great Recovery Project (2013).

The *Toaster For Life’s* modular design and use of would-be eco-materials would also enable users to recycle, customise and track its individual parts. The speculation implies that CAD and domestic fabrication have become mainstream activities in the near future. Aluminium and heat resistant bio-plastics would be readily accessible for home 3D printing and both materials could be efficiently and repeatedly recycled (Figure 9). Domestic fabrication would also give people the freedom to customise their spine toaster as and when they please, perhaps altering the colour of the product’s casings (Figure 10) or even adding an additional toasting chamber. The proposal further frames the product as inherently trackable due to the majority of its parts being fitted with nano RFID tags; a smaller but more powerful iteration of today’s radio frequency technology (see Figure 2). This would enable potential users to ascertain the whereabouts of individual componetry throughout the product’s entire lifecycle. Data from each part would be stored on the attached tag. When tagged parts are within the required proximity, their data would be transmitted from their tag to the *Synchron Berners-Lee 3* micro-processor board (see Figure 7). The *Berners-Lee 3* would be equipped with wireless and geo-location abilities and would therefore be able to continually log details online about the toaster’s current state of operation. Similar

'synching' interactions would occur at different stages of each part's lifecycle, for example, at manufacture, points of distribution, during usage and then finally at disposal when they are returned to Synchron – the fictional environmentally conscious manufacturer of the *Toaster For Life* – for recycling and reuse in the production of future spime products.

The *Toaster For Life's* aesthetic sensibilities also seeks to reflect sustainability, namely notions of 'openness' and 'transparency'. Regards the product's clear casing, I was inspired in part by Daniel Weil's 1981 design *Radio In A Bag* (Figure 11 - left) but more so by a range of consumer products made by Freeplay. Housed in transparent casings, the manufacturer's radios and torches (Figure 11 - right) are extremely popular in developing nations, where self repair, customisation and 'off the grid' cultures are, by necessity, more prevalent. The design's casing and accessible assembly is envisaged as a way of inviting users to also 'touch' and gain deeper practical insight into the object's construction, materiality and functionality.



Figure 9 Within the speculation, the 3D printing and the recycling of aluminium and bio-plastic electronic product parts are mainstream domesticated activities.



*Figure 10 The prototype's modular design offers potential for personal customisation. An example of such is presented above – changes to the products' styling in the form of new coloured casings.*



*Figure 11 The Toaster For Life prototype's casing is a metaphor for 'transparency' of both form and function. It aims to entice users to open up the product and actively engage in sustainable practices including repair and upgrades. I took inspiration from these designs – Daniel Weil's 'Radio In A Bag' (left) and Freeplay's products (right).*



## 5. Initial Conclusions

The *Toaster For Life* speculation seeks to challenge the ongoing legitimacy of centralised industrial product design in an era of increasing material scarcity, electronic waste and climate change. By envisioning an alternate strategy for the design, manufacture and consumption of an Internet connected device, the proposal aims to provoke audiences to also consider the sustainable potential of lesser-known practices and technologies which are central to today's decentralised technological sub-cultures. In doing so, *Toaster For Life*, like other design fictions, strives to “inspire an audience to think not only about what they do want for their future... but also what they do not want” (Auger, 2013, p.32). As a means to ‘open up’ a discursive space amongst audiences, my ‘design fiction object’ could also be described as a ‘discursive product.’ Here I have adapted Tharp & Tharp’s term *discursive design*, a method they characterise as:

“The creation of utilitarian objects/services/interactions whose primary purpose is to communicate ideas – artefacts embedded with discourse. These are tools for thinking; they raise awareness and perhaps understanding.” (Tharp & Tharp, 2013, p.406).

Frayling separates design led research into three sub-categories – *into*, *through* and *for*. I see strong parallels between Tharp and Tharp’s definition and Frayling’s description of research *for* design (RfD):

“Research... where the thinking is... *embodied in the artefact*, where the goal is not primarily communicable knowledge in the sense of the verbal communication, but in the sense of visual or iconic or imagistic communication.” (Frayling, 1993, p.5).

However, as expressed earlier, I consider spime-based design fictions to not only be a lens for reflection for audiences *but also for the designers who seek to envision them*. In many ways, the design fiction process also corresponds with research *through* design (RtD). For me, the practicing of the design fiction was, like RtD, “a route to discovery [where] the synthetic nature of design allows for richer and more situated understandings than those produced through more analytic means” (Gaver, 2012, p.942). This indicates that the relationship between RfD and RtD is perhaps more fluid than Frayling’s original delineation suggests.

While ‘good’ for the ensuing speculation, the use of ‘new media’ is a highly nuanced approach which can also have important implications for how design fictions are ‘crafted.’ Hales (2013, p.7) notes that “as media objects, design fictions are deeply implicated in the ecology of the media situation... they cannot be untangled from that milieu.” As a self-described ‘conventionally trained service to industry’ product designer, I have found this ‘entanglement’ difficult to negotiate. Although the method removes the constraints of normative market-led product design, “constraints still exist... without them the design speculations could drift off into neverlands and dreamscapes” (Auger, 2013, p.34). Essentially, the crafting of the design fiction required the same level of attention to detail and expertise that would be needed if I were actually trying to design and produce the ‘real’

product. This created a 'blurred boundary' between normative product design practice and design fiction practice and was consequently a source of tension during the design process. With its focus on narrative and the embodiment of ideas, the use of design fiction could begin to facilitate "alternative value systems for designers" (Voss et al, 2015, p.2). Chapman & Gant contend that:

"Creation and consumption is both a natural and integral facet of human behaviour... problems arise when these deep motivations are expressed physically (e.g. objects, materials and new technologies), as opposed to metaphysically (e.g. stories, ideas and friendships)." (Chapman & Gant, 2007, p.6).

As an approach, design fiction negotiates the 'metaphysical' in that it is not concerned with the commercialisation of product designs but *the meaning of products and the futures they might bring*. Having said this, questions remain regard the rhetorical and ideological nature of 'design fiction objects.' As Gaver (2012, p.944) stresses, such artefacts embody "the designer's best judgement about how to address the particular configuration of issues in question." Like Sterling, I see spimes as a more preferable alternative to today's unsustainable models of production and consumption. The *Toaster For Life* is thus representative of my values and my ideology. However, I also understand that the notion of *what is preferable* varies from person to person. I therefore maintain that the *Toaster For Life* is a 'conversation starter', not an 'end product.' Whether or not others see spimes and sustainable futures in the same manner as myself is up to them, the *Toaster For Life* is a means for getting people to talk about such views.

## 6. Future Work

Deciding *where, when* and with *whom* such conversations take place is the next important step for this project. Voss et al (2015, p.3) highlight the lack of engagement with broader audiences across speculative design culture – "despite explicitly advocating [their] potential for 'helping people participate more actively'... many speculative design projects either operate as stand-alone spectacle, or... with those deemed to have 'expertise' – scientists and technologists, political scientists, economists." Thus, rather than being discussed solely within academia or presented in an art gallery setting like many critical design proposals, I see 'participatory' workshops as a more valuable forum to showcase the *Toaster For Life* design fiction. It is envisaged that this context would better facilitate discussions around peoples' perceptions of unsustainable technological product presents and potential sustainable spime-based futures.

Different audiences will likely focus on different themes. I intend to firstly organise a workshop to discuss the *Toaster For Life* proposal in relation to practical domestic issues including convenience, safety, efficiency, cost, time, quality, expertise, product warranty and aesthetics. Another workshop will be aimed at those working within the IoT field with the view to understanding how the fictional product is perceived in relation to present IoT devices. Both workshops would see *a discursive object being used to open up a discursive space*. As with RtD and design fiction, the aim of such endeavour is to generate insights for

additional design praxis – further discursive objects – which, in turn, can be used to stimulate further debate. It is, in essence, an ongoing reflective process.

With the *Toaster For Life* representing only three of Stead's (2015) seven spime design criteria, I already see numerous opportunities for envisioning further worlds in which 'actually futuristic' spime products exist. The *Toaster For Life* principally focuses on the sustainability of a connected product's physical attributes. Could a spime object also be designed to sustainably accommodate changes to its digital characteristics such as software? Might the copious amounts of data that a spime generates be stored on, and, accessed via, the object itself? Or like today, would said data continue to disappear into the environmental uncertainty that is 'the cloud'? And how might spimes be framed in relation to the negative rhetoric presently associated with the IoT such as privacy, surveillance and the growing agency of connected products? In this light, the *Toaster For Life* can be seen as the first in an exploratory body of work which uses Sterling's concept as its lens. Looking further ahead, several spime orientated projects could well provide the foundation for a design manifesto for a sustainable Internet of Things.

**Acknowledgements:** Many thanks to Paul Coulton and Mike Hazas for their supervision and help with this project. This work is funded by the Digital Economy programme (RCUK Grant EP/G037582/1), which supports the HighWire Centre for Doctoral Training. (<http://highwire.lancs.ac.uk>).

## 7. References

- Auger, J. (2013) Speculative Design: Crafting The Speculation, *Digital Creativity*, Vol.24(1), pp. 11–35.
- Bleecker, J. (2009) *Design Fiction: A Short Essay On Design, Science, Fact & Fiction*, <http://tinyurl.com/qhcfm2m>, (Assessed 25th October, 2015).
- Bleecker, J. (2014) *TBD Catalog (1st edition)*, Near Future Laboratory LLC.
- Bonanni, L., Vargas, G., Chao, N., Pueblo, S., and Ishii, H. (2009) Spime Builder: A Tangible Interface For Designed Hyperlinked Objects, in: Proc. *TEC' 09*, ACM, pp. 263–266.
- Bosch, T. (2012) *Sci-Fi Writer Bruce Sterling Explains the Intriguing New Concept of Design Fiction*, <http://tinyurl.com/78sz3zg>, (Assessed 25th October, 2015).
- Chapman, J., and Gant, N. (2007) *Designers, Visionaries & Other Stories: A Collection Of Sustainable Design Essays, (1st edition)*, Earthscan.
- Chiodo, J. (2005) *Design For Disassembly Guidelines*, <http://tinyurl.com/py5qof9>, (Assessed 25th October, 2015).
- Dunne, A., and Raby, F. (2007) *Critical Design FAQ*, <http://tinyurl.com/d5wzdc>, (Assessed 25th October, 2015).
- Fairphone. (2015) <https://www.fairphone.com/phone/>, (Assessed 25th October, 2015).
- Foster, N. (2013) *The Future Mundane*, <http://tinyurl.com/o5m67qs>, (Assessed 25th October, 2015).
- Frayling, C. (1993) *Research In Art And Design, Royal College of Art Research Papers, 1(1)*, pp. 1–9.
- Freeplay. (2015) <http://www.freeplayenergy.com>, (Assessed 25th October, 2015).
- Gaver, W. (2012) What Should We Expect From Research Through Design? in: Proc. *CHI '12*, pp. 937–946.

- Gaustad, G., Olivetti, E., and Kirchain, R. (2010) Design For Recycling, in: *Journal of Industrial Ecology*, Vol.14(2), pp. 286–308.
- Great Recovery. (2013) *The Great Recovery Report: Investigating The Role Of Design In The Circular Economy*, <http://tinyurl.com/q2q43sg>, (Assessed 25th October, 2015).
- Greenpeace. (2014) *Green Gadgets: Designing The Future – The Path To Greener Electronics*, <http://tinyurl.com/kogp9hb>, (Assessed 25th October, 2015).
- Hales, D. (2013) Design Fictions: An Introduction And Provisional Taxonomy, in: *Digital Creativity*, Vol.24(1), pp. 1–9.
- Kirby, D. (2010) The Future is Now: Diegetic Prototypes And The Role Of Popular Films In Generating Real-world Technological Development, in: *Social Studies of Science*, Vol.40(1), pp. 41–70.
- Maly, T. (2012) *Spimes: Junk Philosophy*, [http://tinyurl.com/oers\\_u95](http://tinyurl.com/oers_u95), (Assessed 25th October, 2015).
- McEwen, A., and Cassimally, H. (2013) *Designing The Internet Of Things*, (1st edition), John Wiley & Sons.
- MIT Media Lab. (n.d) *Design Fiction*, <http://tinyurl.com/ok247ck>, (Assessed 8th November, 2015).
- Nova, N., Kwon, N., Miyake, K., and Chiu, W. (2012) *A Digital Tomorrow*, <http://tinyurl.com/q2ynotx>, (Assessed 25th October, 2015).
- Phonebloks. (2015) <https://phonebloks.com>, (Assessed 25th October, 2015).
- Project Ara. (2015) <http://projectara.com>, (Assessed 25th October, 2015).
- PuzzlePhone. (2015) <http://puzzlephone.com>, (Assessed 12th November, 2015).
- Restart Project. (2015) <http://therestartproject.org>, (Assessed 25th October, 2015).
- Slade, G. (2007) *Made To Break: Technology & Obsolescence In America*, (1st edition), Harvard University Press.
- Sterling, B. (2004) *Dumbing Down Smart Objects*, <http://tinyurl.com/nf69xkw>, (Assessed 25th October, 2015).
- Sterling, B. (2005) *Shaping Things*, (1st edition), MIT Press.
- Sterling, B. (2014) *The Epic Struggle Of The Internet Of Things*, (1st edition), Strelka Press.
- Sterling, B. (n.d) *The European Graduate School: Bruce Sterling – Seminars/Workshops/Lectures: The Media Philosophy Of The Internet Of Things*, <http://tinyurl.com/nhbysm3>, (Assessed 25th October, 2015).
- Tanenbaum, J. G. (2011) *What Is Design Fiction? Does It Have Any Limitations?*, <http://tinyurl.com/q3z7yzw>, (Assessed 25th October, 2015).
- Taylor, I. J., and Harrison, A. (2008) *From P2P & Grids To Services On The Web: Evolving Distributed Communities*, (1st edition), Springer.
- Tharp, B. M., and Tharp, S. M. (2013) Discursive Design: Modes And Audience, in: *Proc. Nordes '13*, 5, pp. 406–409.
- Torrone, P. (2006) Owner's Manifesto – The Maker's Bill Of Rights, in: *Make Magazine*, Vol.4, November, p. 156.
- Voss, G., Revell, T., and Pickard, J. (2015) *Speculative Design & The Future Of An Ageing Population Report 2: Techniques*, Government Office for Science Report, <http://tinyurl.com/pxyqqvs>, (Assessed 25th October, 2015).
- Webster, K. (2015) *The Circular Economy: A Wealth Of Flows*, (1st edition), Ellen MacArthur Foundation Publishing.
- Weil, D. (1981) <http://tinyurl.com/q47sngh>, (Assessed 25th October, 2015).

*Michael Stead*

Stead, M. (2015) Spimes and Speculative Design: Sustainable Product Futures Today, presented at Anticipation 2015: First International Conference On Anticipation, Trento, Italy, November 5-7, 2015, <http://tinyurl.com/jtwd8bt>

About the Author:

**Michael Stead** holds a Masters in both Product Design and Research: Digital Innovation. He has worked as a commercial product designer for clients including the BBC and The Big Issue. His PhD research focuses on the environmental impacts of industrial product design in the age of ubiquitous computing.