

A TRANSFORMATION OF SELF-DISCRIMINATION RESPONSE FUNCTIONS IN ACCORDANCE WITH THE ARBITRARILY APPLICABLE RELATIONS OF SAMENESS, MORE THAN, AND LESS THAN

SIMON DYMOND AND DERMOT BARNES

UNIVERSITY COLLEGE CORK, IRELAND

In Experiment 1, 2 experimental subjects were given pretraining of nonarbitrary relations that brought their responses under the control of four contextual stimuli; same, opposite, more than, and less than. One control subject was not exposed to this pretraining. The 2 pretrained subjects and the 3rd nonpretrained subject then received training in six arbitrary relations, the following four relations being the most crucial: same/A1-B1, same/A1-C1, less than/A1-B2, more than/A1-C2. All 3 subjects were then tested for seven derived relations, the following three relations being the most important: same/B1-C1, more than/B1-C2, less than/B1-B2. The 2 pretrained subjects, but not the nonpretrained subject, showed the derived relations. One of the stimuli (B1) from the relational network and two novel stimuli (X1 and X2) were then used to train three different self-discrimination responses on three complex schedules of reinforcement. That is, all 3 subjects were trained to pick X1 if they had not emitted a response, to pick B1 if they had emitted one response only, and to pick X2 if they had emitted two responses only. The 2 pretrained subjects, but not the nonpretrained subject, showed the predicted transformation of self-discrimination response functions in accordance with the relations of sameness, more than, and less than (i.e., no response, pick B2; one response only, pick C1; and two responses only, pick C2). In Experiment 2, 2 new subjects were employed, and the arbitrary relational training and testing phases were modified to control for a procedural artifact that may have contributed to the results of the first experiment. Experiment 2 replicated the findings of Experiment 1. The pattern of results support the utility of a relational frames approach to understanding derived stimulus relations.

Key words: self-discrimination response function, arbitrarily applicable relations, same, more than, less than, transformation of functions, humans

In a recent article we reported that human adult self-discrimination response functions may transfer through equivalence relations (Dymond & Barnes, 1994). Subjects were first trained in six matching-to-sample tasks (i.e., if A1 select B1, A1-C1, A2-B2, A2-C2, A3-B3, A3-C3) and were then tested for the formation of three equivalence classes (i.e., A1-B1-C1, A2-B2-C2, A3-B3-C3). Following a successful equivalence test, subjects were trained in two conditional self-discrimination responses on a time-based reinforcement-schedule task. If subjects did not emit an operant response on this task, choosing Stimulus B1 was reinforced; if they did emit one or more responses, choosing Stimulus B2

was reinforced. Finally, they were tested for a transfer of these self-discrimination response functions through derived equivalence relations (i.e., no response, choose C1; one or more responses, choose C2).

A number of other studies have demonstrated a derived transfer of stimulus control through equivalence relations using both discriminative (but not self-discriminative) functions (e.g., Barnes, Browne, Smeets, & Roche, 1995; Barnes & Hampson, 1993; Barnes & Keenan, 1993b; Cullinan, Barnes, Hampson, & Lyddy, 1994; de Rose, McIlvane, Dube, Galpin, & Stoddard, 1988; de Rose, McIlvane, Dube, & Stoddard, 1988; Gatch & Osborne, 1989; Hayes, Devany, Kohlenberg, Brownstein, & Shelby, 1987; Kohlenberg, Hayes, & Hayes, 1991; Wulfert & Hayes, 1988) and consequential functions (e.g., Hayes et al., 1987; Hayes, Kohlenberg, & Hayes, 1991). It was significant that self-discrimination response functions can also transfer through equivalence, because such an effect provides additional empirical and conceptual analyses of self-verbalized rule control on schedules of reinforcement (Dymond & Barnes, 1994, pp.

Data from Experiment 1 were presented at the annual conference of the Experimental Analysis of Behaviour Group, London, April 1994, and at the summer meeting of the Behaviour Analysis in Ireland Group, Belfast, June 1993. The experimental work was conducted as part of the first author's doctoral research program under the supervision of the second author.

Requests for reprints should be sent to Dermot Barnes, Department of Applied Psychology, University College Cork, Cork, Ireland (E-mail: IN% "STAY8028@IRUCCVAX.UCC.IE").

264–265; see also Barnes & Keenan, 1989, 1993a, 1994) and contributes to a behavior-analytic interpretation of certain clinical or emotional problems in the human population (see Dymond & Barnes, 1994, p. 252; Hayes & Wilson, 1993).

Although the transfer of self-discrimination response functions through equivalence may have important implications for the analysis of complex human behavior, a number of recent findings suggest that the derived-transfer-of-function effect, in general, may not be restricted to equivalence relations (see Barnes & Keenan, 1993b; Green, Stromer, & Mackay, 1993; Steele & Hayes, 1991). Insofar as a derived transfer may occur in accordance with relations not readily categorized as equivalence, the experimenter interested in human self-discrimination can explore a transfer of self-discrimination response functions through one or more nonequivalence relations. This is the approach we adopted in the current study.

This approach follows from Steele and Hayes (1991), who demonstrated that human teenagers could respond on arbitrary matching-to-sample tasks in accordance with the derived relations (or relational frames) of sameness, opposition, and difference. Specifically, they pretrained subjects to relate identical stimuli (e.g., a short line with a short line) in the presence of one contextual cue, “opposite” stimuli (e.g., a short line with a long line) in the presence of a second contextual cue, and different stimuli (e.g., a short line with a square) in the presence of a third contextual cue. Subjects were then taught an extensive network of conditional discriminations with each of the three contextual cues used in pretraining. For illustrative purposes, consider the following two training trials: [O]A1/B1-B2 and [O]A1/C1-C2. The letter O represents the arbitrary form that had been established during pretraining as the contextual cue for opposite. A1 represents the sample stimulus, and the two alphanumeric characters connected by a hyphen are the comparison stimuli. Choosing the italicized comparison was reinforced. A later test trial was as follows: [O]B2/C1-C2. If subjects were responding in accordance with an equivalence relation, they would choose C2, because during training they had selected C2 and B2 when A1 was the sample. Alternatively, if the

opposite stimulus functioned as a conditional discriminative stimulus (i.e., subjects ignored the sample), they would select C2, because choosing it had been reinforced in the presence of the O stimulus. In fact, subjects chose C1, indicating that the relational frame of opposition functioned in the task. Although this performance could be interpreted in terms of equivalence (i.e., sameness) and nonequivalence (i.e., opposition), a third arbitrary relation of difference was also examined in the Steele and Hayes research. Control in accordance with this third relation suggested that the concepts of equivalence and nonequivalence alone were unable to account for the test performances produced by all of the subjects in the study.

These and other findings (e.g., Barnes & Keenan, 1993b; Green et al., 1993) indicate that derived relations other than equivalence may be examined in the behavioral laboratory. As yet, however, no published research has shown derived transfer of functions using the types of relational frame procedures employed by Steele and Hayes. Experiments 1 and 2 of the present study attempted this demonstration, using the self-discrimination procedures developed in our previous stimulus equivalence research (Dymond & Barnes, 1994).

Because we wished to extend the findings of Steele and Hayes (1991), the current study focused on establishing self-discrimination response functions in accordance with three derived relations, two of which were not examined in the Steele and Hayes research. Specifically, 2 experimental subjects (in Experiment 1) were pretrained in accordance with sameness (examined by Steele and Hayes) and more than and less than relations (not examined by Steele and Hayes). Responding in accordance with sameness was trained using procedures similar to those employed by Steele and Hayes (e.g., subjects were trained to pick a short line comparison stimulus given a short line sample in the presence of a same contextual cue). Responding in accordance with more than and less than relations was trained using comparisons that were either more than or less than the sample along some physical dimension. For example, subjects were trained to pick a two-star comparison in the presence of a three-star sample given the less than cue and to pick a six-star

comparison in the presence of the three-star sample given the more than cue. After the subjects had been successfully pretrained, they were trained in six arbitrary relations using the three contextual cues. The four critical relations were: same/A1-B1, same/A1-C1, less than/A1-B2, more than/A1-C2. The subjects were then tested for seven derived relations, the following three relations being the most important: same/B1-C1, more than/B1-C2, less than/B1-B2 (see Figure 1, Panel 1, for a schematic representation of the most important of the trained and tested relations). To establish derived self-discrimination response functions in accordance with sameness, more than, and less than relations, three response functions were required. Therefore, subjects were trained using three complex schedules of reinforcement to produce three performances: (a) no response, (b) one response only, and (c) two responses only. If the derived sameness, more than, and less than relations have been established (i.e., B1 is the same as C1, B2 is less than B1, and C2 is more than B1) and choosing Stimulus B1 after making one response has been reinforced, it is possible that the subject, without further training, will then choose (a) C1 following one response (i.e., C1 acquires the same function as B1), (b) B2 following no response (i.e., B2 acquires a response function that is less than the B1 function), and (c) C2 following two responses (i.e., C2 acquires a response function that is more than the B1 function). The reader should note that the term *transformation* of functions is used to describe this effect instead of *transfer*, because the explicitly trained one-response function of B1 does not transfer to B2 and C2 (i.e., B2 and C2 do not acquire one-response functions); rather, the one-response function of B1 *transforms* the functions of B2 and C2 in accordance with more than and less than relations. Experiment 1 was designed to examine the transformation of self-discrimination response functions in accordance with the arbitrarily applicable relations of sameness, more than, and less than.

EXPERIMENT 1

METHOD

Subjects

Three subjects, 2 male (18 and 26 years old) and 1 female (23 years old), participated

in the experiment. All subjects were recruited through personal contacts. Two subjects were educated and employed in areas outside of psychology. One subject was a nonpsychology undergraduate, attending University College Cork. None of the subjects had any knowledge of stimulus equivalence or relational frame theory. Subjects were paid an hourly rate (IR£2.00 or about \$3.00) for participation. They could also earn money while performing the experimental tasks; each point earned during the experiment was equivalent to one Irish penny (about 1.5 cents). Experimental sessions were arranged so that subjects did not meet each other in the vicinity of the laboratory, and all subjects were instructed not to tell anyone about their participation in the study.

Apparatus and Materials

Subjects were seated at a table in a small experimental room with an Acorn Computer Ltd., British Broadcasting Corporation (BBC) Master Series 128 microcomputer with a Pace floppy disk drive and a computer monitor that displayed white characters on a black background. White circular paper dots (1 cm in diameter) were glued to the Z, V, and M keys on the computer keyboard to designate them as response keys. Stimulus presentation and the recording of responses were controlled by the computer, which was programmed in BBC BASIC.

Experimental Tasks

Matching to sample. All of the arbitrary stimuli used in the experiment were three-letter nonsense syllables that were selected randomly, for each subject, from a pool of 16 (e.g., CUG, VEK, YIM, BEH). For matching-to-sample trials, the contextual cue (i.e., a nonsense syllable designated same, opposite, more than, or less than) appeared in the center of the computer screen, two 2 cm from the top. Following a 1.5-s delay, the sample stimulus (e.g., A1) appeared 4 cm directly below the contextual cue, followed 1.5 s later by the comparison stimuli, which were positioned to the left and right of the sample, 4 cm from the bottom of the screen (i.e., no observing responses to the contextual cue or sample were required). For those trials on which three comparison stimuli were presented, the third comparison stimulus was also posi-

Schematic Representation of Trained and Tested Relations

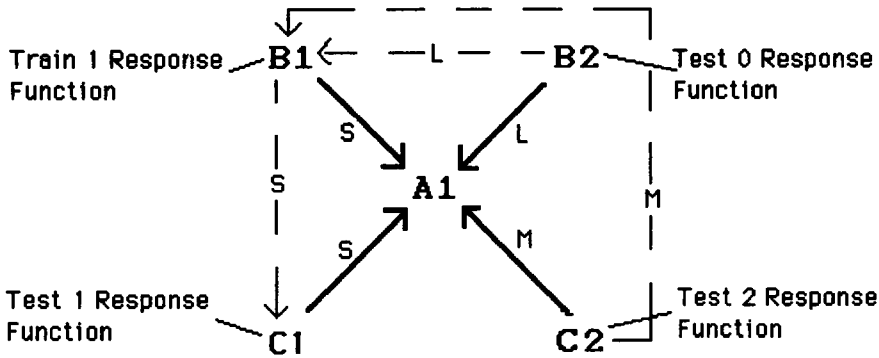

Non-Arbitrary Relational Pretraining (Experimental Subjects Only)

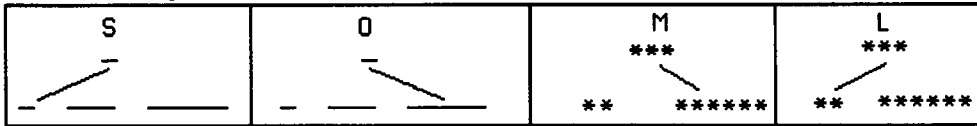

Arbitrary Relational Training

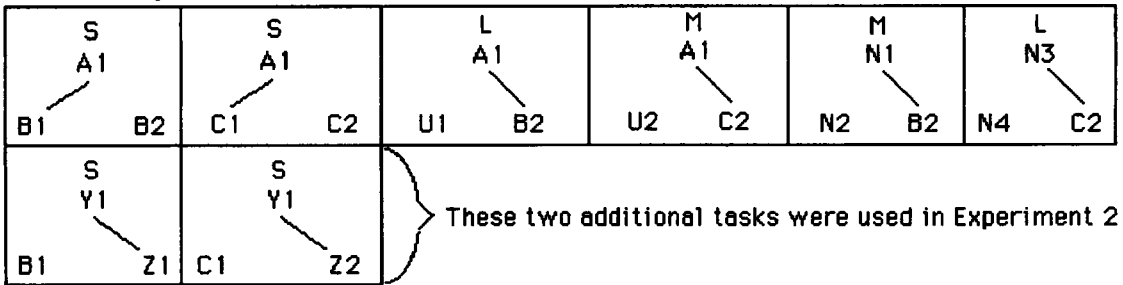

Arbitrary Relational Testing

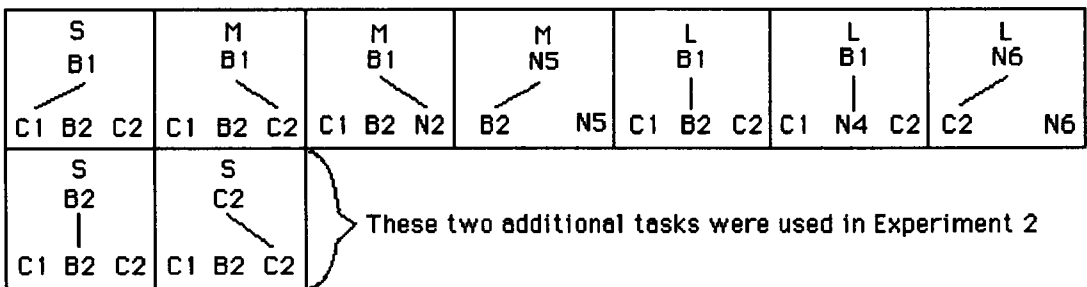

Fig. 1. Experiments 1 and 2. Panel 1 (top): Schematic representation of trained and tested relational network. Solid arrows indicate trained relations, and broken arrows indicate derived or tested relations. The letters S, M, and L indicate the arbitrary relations of same, more than, and less than. The diagram also shows that a one-response function was trained using the B1 stimulus, and tests examined the transformation of the trained function in accordance with the relations of sameness (C1, one response), more than (C2, two responses), and less than (B2, no response). Panel 2 (second row): Examples of the nonarbitrary relational pretraining tasks that were used to establish the contextual functions of same (S), opposite (O), more than (M), and less than (L). Panels 3 and 4: Arbitrary relational training and testing tasks. Trained and predicted derived relations are indicated by lines from samples to comparison stimuli.

tioned 4 cm from the bottom of the screen, but directly below the sample. On each matching-to-sample trial the position of the comparison stimuli was varied randomly (i.e., the correct nonsense syllable could appear in any position with equal probability). Subjects selected a comparison stimulus by pressing one of two (or three) keyboard keys (marked by white paper dots) whose positions corresponded to the stimuli on the screen (i.e., one key was on the left, another on the right, and where appropriate, the third was in the middle). On those matching-to-sample trials in which no contextual cue was presented, the same format was used except that the computer presented the sample and comparisons in the absence of a contextual cue.

Schedule performance. During schedule performance trials, the words "SPACE-BAR TASK" appeared in the center of the monitor screen and subjects pressed the space bar on the computer keyboard (the auto-repeat function was disabled for the entire study). On each trial, the computer quasi-randomly (see next paragraph) generated one of three reinforcement schedules: (a) a recycling conjunctive differential-reinforcement-of-other-behavior fixed-time 5-s (DRO FT 5-s) schedule, (b) a recycling conjunctive FT 5-s fixed-ratio (FR) $> 0 < 2$ schedule, or (c) a recycling conjunctive FT 5-s FR $> 1 < 3$ schedule. The recycling conjunctive DRO FT 5-s schedule required that the subject not respond at all (i.e., not press the space bar) during the entire 5-s programmed interval. If this requirement was met, the subject's performance was defined as correct. If the subject responded during the programmed 5-s interval, the performance was defined as incorrect. The recycling conjunctive FT 5-s FR $> 0 < 2$ schedule required that the subject respond once, and only once, during the programmed 5-s interval. If this requirement was met, the subject's performance was defined as correct. If the subject did not respond during the programmed 5-s interval or emitted more than one response, the performance was defined as incorrect. The recycling conjunctive FT 5-s FR $> 1 < 3$ schedule required that the subject respond twice, and only twice, during the programmed 5-s interval. If this requirement was met, the subject's performance was defined as correct. If the subject did not respond during the programmed

5-s interval or emitted any number of responses other than two, the performance was defined as incorrect.

For the first trial, and for every trial that followed a correct schedule performance, the computer generated one of the three schedules with equal probability. On trials that followed an incorrect schedule performance, however, the computer simply presented the previously generated schedule. Thus, subjects (on average) could not produce a correct schedule performance across a third of the trials by consistently emitting the same pattern of responding (e.g., pressing the space bar once on every trial).

Programmed consequences. The correct completion of a matching-to-sample or schedule control training trial removed the stimulus display and produced "CORRECT" in the center of the screen, accompanied by a high-pitched beep for 1.5 s. The incorrect completion of a schedule control or matching-to-sample training trial removed the stimulus display and produced "WRONG" in the center of the screen for 1.5 s, without auditory feedback. A message on the righthand lower side of the screen appeared with both types of feedback indicating the total number of points earned *within a given session* (i.e., "POINTS EARNED = 4"); 1 point was added for each correctly completed trial, and 1 point was deducted for each incorrect response. A 1-s intertrial interval (i.e., the screen cleared and remained blank) followed all programmed consequences. On all matching-to-sample test trials, the computer omitted all feedback messages and proceeded directly to the intertrial interval. Feedback was always provided on schedule performance trials, but during self-discrimination test trials (outlined later), the "points earned" feedback was not presented.

The computer controlled for typing errors on all tasks (i.e., hitting one of the nonfunctioning keys on the keyboard); the error-correction message "YOU HAVE MADE A MISTAKE—TRY AGAIN" appeared on the screen for 2 s and immediately thereafter, the subject was presented with the same contextual cue (when present), sample, and comparison stimuli. If a nonfunctioning key was pressed during a schedule control trial, the same error-correction message was presented for 2 s, and when the message cleared from the

screen the same schedule control trial commenced at the point in the interval at which the nonfunctioning key had been pressed. The appropriate feedback (if programmed) was presented at the end of a matching-to-sample or schedule control trial, even when an error-correction message had been presented during the trial.

Procedure

Subjects 1, 2, and 3 attended three to six separate sessions, each lasting between 30 min and 2 hr. Two subjects (1 and 2) were exposed to same/opposite and more than/less than pretraining. They were then trained and tested on six and seven arbitrary relational tasks, respectively (see Figure 1, Panel 1 for a schematic representation of the trained and tested relations). These tasks examined the effects of the three contextual cues of same, more than, and less than (i.e., although the relational cue of opposite was pretrained, its effects were not examined in this experiment). Subject 3 was exposed to this arbitrary relational training and testing without pretraining with the contextual cues. Following the relational training and testing, all 3 subjects were exposed to a three-stage self-discrimination training procedure during which they were trained to discriminate three different response patterns on three complex schedules of reinforcement (see Figure 2). Once the self-discrimination performances had been successfully established, the subjects were reexposed to the relational test and the final stage of the self-discrimination training (to ensure that the relational test and self-discrimination performances were both intact). Finally, the subjects were exposed to two self-discrimination tests, both of which examined a transformation of the self-discrimination response functions in accordance with the relations of same, more than, and less than.

Nonarbitrary relational pretraining. The two experimental subjects were given same/opposite and more than/less than pretraining (Figure 1, Panel 2). When seated in front of the computer, subjects were read the following instructions by the experimenter:

The screen will show some figures or shapes. There will be either two or three figures or shapes at the bottom of the screen. Your task is to choose one of these figures or

shapes as the correct one. If you want to choose the shape on the left, press the marked key on the left, if you want to choose the shape in the middle, press the marked key in the middle, and if you want to choose the shape on the right, press the marked key on the right. (adapted from Steele & Hayes, 1991, p. 521)

Pretraining for same/opposite control. During same/opposite pretraining, contextual functions were established for two contextual cues. For illustrative purposes consider the following example. The contextual cue for same (e.g., CUG) was followed by the sample, and then by three comparison stimuli. If the sample consisted of a short line, then the comparisons were short, medium, and long lines, and in the presence of the same contextual cue, selecting the short line was defined as correct (i.e., same, short line–short line). There were a total of four such tasks using line length as the relevant dimension (i.e., same, long line–long line; opposite, long line–short line; same, short line–short line; opposite, short line–long line), and together these four tasks constituted one problem set. Different stimulus dimensions were used to create eight problem sets: short to long lines; small squares to large squares; few dots to many dots; closely spaced to distantly spaced lines; a scale with a cursor located at the top, bottom, or middle; a scale with a cursor located at the left, right, or middle; figures drawn in very thick to thin lines; tall to short lines (adapted from Steele & Hayes, 1991, p. 523). Subjects received explicit training on a minimum of three problem sets. In this way, same/opposite control was established. It is important to understand that the opposite cue controlled selection of the comparison least like the sample. For example, in the presence of the opposite cue and three dots as sample, selecting the most dots (i.e., 12 dots) was defined as correct (i.e., choosing six dots, but not 12 dots, was defined as incorrect). If reinforcement had occurred for choosing either six dots or 12 dots, this would not constitute opposite contextual control but more than control (i.e., either six or 12 dots is more than the three-dot sample, but only the 12-dot sample is the “opposite”). In effect, the opposite cue controlled selection of the comparison that was least like the sample (along some physical dimension) but did

SELF-DISCRIMINATION TRAINING

SELF-DISCRIMINATION TRAINING (STAGE 1):

TASK 1:

NO RESPONSE = X 1
ONE RESPONSE = B 1
TWO RESPONSES = X 2

TASK 2:

X1 /	B1 	X2 \
X1 B1 X2	X1 B1 X2	X1 B1 X2

SELF-DISCRIMINATION TRAINING (STAGE 2):

TASK 1:

NO RESPONSE = X 1
ONE RESPONSE = B 1
TWO RESPONSES = X 2

TASK 2:

NO	S	A	M	P	L	E
X1 B1 X2	X1 B1 X2	X1 B1 X2	X1 B1 X2	X1 B1 X2	X1 B1 X2	X1 B1 X2

SELF-DISCRIMINATION TRAINING (STAGE 3):

TASK 1:

NO RESPONSE =	NO
ONE RESPONSE =	STIMULI
TWO RESPONSES =	STIMULI

TASK 2:

NO	S	A	M	P	L	E
X1 B1 X2	X1 B1 X2	X1 B1 X2	X1 B1 X2	X1 B1 X2	X1 B1 X2	X1 B1 X2

SELF-DISCRIMINATION TESTING

SELF-DISCRIMINATION TEST 1:

TASK 1:

NO RESPONSE =	NO
ONE RESPONSE =	STIMULI
TWO RESPONSES =	STIMULI

TASK 2:

NO	S	A	M	P	L	E
C1 B2 C2	C1 B2 C2	C1 B2 C2	C1 B2 C2	C1 B2 C2	C1 B2 C2	C1 B2 C2

SELF-DISCRIMINATION TEST 2 :

TASK 1:

NO	S	A	M	P	L	E
C1 B2 C2	C1 B2 C2	C1 B2 C2	C1 B2 C2	C1 B2 C2	C1 B2 C2	C1 B2 C2

TASK 2:

NO RESPONSE =	NO
ONE RESPONSE =	STIMULI
TWO RESPONSES =	STIMULI

Fig. 2. Experiments 1 and 2. Schematic representation of self-discrimination training Stages 1, 2, and 3 and self-discrimination Tests 1 and 2.

not control selection of the comparison that was simply more than or less than the sample.

At the beginning of same/opposite pre-training, the four tasks from the first problem set were presented in a quasi-random order in blocks of four trials (each task from the problem set presented once every four trials) until the subject produced four consecutive correct responses. Subjects were then trained,

in the same manner, on a second problem set and subsequently on a third set. Then all three problem sets were presented in a quasi-random order (i.e., one example from each problem set presented every three trials) until subjects produced six consecutive correct responses.

Subjects were then tested (i.e., no feedback) on three novel problem sets (Sets 4, 5,

and 6). These were presented in a quasi-random order (one task from each of the three novel problem sets presented once every three trials). If subjects produced six correct responses across the first six trials, the pretraining was terminated. If subjects failed to meet this criterion, they were retrained (feedback on all trials) on Sets 1 to 4. Tasks were presented in a quasi-random order (i.e., one task from each of the four problem sets was presented across every four trials) until subjects produced eight consecutive correct responses. Subjects were then tested on Sets 5 and 6 and a completely novel Set 7. These were presented in a quasi-random order (one task from each of the three problem sets presented once every three trials). If subjects produced six correct responses across the first six trials, the pretraining was terminated. If subjects failed to meet this criterion they were retrained on Sets 1 to 5. Tasks were presented in a quasi-random order (i.e., an example from each of the five sets was presented once every five trials) until subjects produced 10 consecutive correct responses. Subjects were then tested on Sets 6 and 7 and a completely novel Set 8. These were presented in a quasi-random order (one task from each of the three problem sets presented once every three trials). If the subject produced six correct responses across the first six trials, the pretraining was terminated. Neither of the 2 subjects failed at this level of testing.

Pretraining for more than/less than control. Following successful completion of same/opposite pretraining, the 2 subjects received more than/less than pretraining. Another two contextual stimuli (i.e., nonsense syllables that had not been used as same and opposite) were trained as more than and less than using sample and comparison stimuli that differed along a single physical dimension (e.g., more than, three stars–six stars; see Figure 1, Panel 2). The eight problem sets consisted of (a) two, three, and six stars; (b) three circles of different sizes; (c) one, six, and nine triangles; (d) three rectangles of different sizes; (e) three semicircles of different sizes; (f) five, 10, and 20 X shapes; (g) three diamond shapes of different sizes; and (h) eight, 11, and 25 S shapes. There were three important ways in which more than/less than pretraining differed from same/opposite pretraining.

First, only two comparison stimuli were presented to the subject on each trial, thus avoiding the ambiguous situation in which, for example, given the more than cue with three stars as the sample and two, four, and six stars as the comparisons, there would be two correct choices (i.e., the four stars or six stars are both more than the three-star sample). Note also that the use of a three-comparison task could have inadvertently established the more than cue as functionally equivalent to the opposite cue. For instance, a subject might consistently select the six-star comparison in the presence of the three-star sample and therefore fail to learn that the more than four-star comparison is also correct (i.e., the more than cue would control selection of the opposite comparison rather than a comparison stimulus that was simply more than the sample). The use of only two comparison stimuli (combined with a second difference outlined below) thereby ensured that opposite relational control could not occur during more than/less than pretraining. The second difference in the more than/less than pretraining (relative to same/opposite) was that neither of the comparison stimuli was identical to the sample; one comparison stimulus was more than and the other was less than the sample (e.g., a circle with a 1-cm diameter presented as a sample with two comparison circles measuring 0.5 cm and 5 cm in diameter, respectively). This design ensured that more than/less than control would not be confounded with opposite control (i.e., in contrast to an opposite pretraining trial in which the sample was located at the opposite end of a physical continuum from the correct comparison stimulus, during more than/less than pretraining the sample was located somewhere *between* the two comparison stimuli along a physical continuum, and thus neither comparison stimulus was the opposite of the sample). The third and final difference in the more than/less than pretraining was that there were only two tasks (instead of four) within each of the eight problem sets (e.g., more than, 1-cm diameter circle as sample, with the 5-cm diameter circle as the correct comparison; less than, 1-cm diameter circle as sample, with the 0.5-cm diameter circle as the correct comparison).

One final point needs to be addressed with regard to the more than/less than pretrain-

ing. In a pilot study it became apparent that for 1 subject the more than and less than contextual cues were controlling behavior in the absence of any discriminative function for the sample stimulus. In effect, the subject was simply selecting the greater of the two comparisons in the presence of the more than cue and was selecting the lesser of the two comparisons in the presence of the less than cue (i.e., the subject was responding to the more than and less than relations between the two comparison stimuli, rather than to the more than and less than relations between the sample and comparison stimuli). In order to suppress this type of nonsample control, but at the same time to avoid complicating the more than/less than pretraining, all subjects were given same/opposite pretraining before more than/less than pretraining. In effect, because the same/opposite pretraining "forced" subjects to respond to the sample-comparison relations (see previous section), this made it more likely that they would continue to do so during the more than/less than pretraining.

The actual training sequence used to establish more than/less than control was similar to the sequence used to establish same/opposite control. Subjects received explicit training on a minimum of three problem sets. At the beginning of more than/less than pretraining, the two tasks from the first problem set were presented in a quasi-random order in blocks of four trials (the two tasks from the problem set presented twice every four trials) until the subject produced four consecutive correct responses. Subjects were then trained, in the same way, on a second problem set and subsequently on a third set. Then all three problem sets were presented in a quasi-random order (i.e., one example from each problem set presented every three trials) until subjects produced six consecutive correct responses. Subjects were then tested on three novel problem sets (Sets 4, 5, and 6). These were presented in a quasi-random order (one task from each of the three novel problem sets presented once every three trials). If subjects produced six correct responses across the first six trials, the pretraining was terminated. If subjects failed to meet this criterion, they were retrained on Sets 1 to 4. Tasks were presented in a quasi-random order (i.e., one task from each of the four

problem sets was presented across every four trials) until subjects produced eight consecutive correct responses. Subjects were then tested on Sets 5 and 6 and a completely novel Set 7. These were presented in a quasi-random order (one task from each of the three problem sets presented once every three trials). If subjects produced six correct responses across the first six trials, the pretraining was terminated. If subjects failed to meet this criterion, they were retrained on Sets 1 to 5. Tasks were presented in a quasi-random order (i.e., an example from each of the five sets was presented once every five trials) until subjects produced 10 consecutive correct responses. Subjects were then tested on Sets 6 and 7 and a completely novel Set 8. These were presented in a quasi-random order (one task from each of the three problem sets presented once every three trials). If the subjects produced six correct responses across the first six trials, the pretraining was terminated. Neither of the 2 subjects failed at this level of testing.

Arbitrary relational training. At the beginning of the arbitrary relational training, subjects were presented with the same instructions that were used for the nonarbitrary relational pretraining, except that (a) the phrase "nonsense syllable(s)" replaced the words "figures" and "shape(s)," and (b) the instructions appeared on the computer screen (i.e., the experimenter did not read the instructions to the subject).

Each of the 3 subjects was trained with six arbitrary relational training tasks that were presented in a quasi-random order within blocks of 60 trials (i.e., 10 exposures to each task within each 60-trial block). The stimuli were 16 nonsense syllables (i.e., three contextual cues and the 13 stimuli designated A1, B1, B2, C1, C2, U1, U2, N1, N2, N3, N4, N5, N6). The six tasks were same/A1-B1, same/A1-C1, less than/A1-B2, more than/A1-C2, more than/N1-B2, less than/N3-C2 (see Figure 1, Panel 3). The two latter tasks were included so that subjects would have a history of reinforcement for selecting B2 and C2 in the presence of the more than and less than contextual cues. All 3 subjects were required to produce a minimum of nine correct responses out of 10 on each of the six tasks, within a 60-trial block, before proceeding to the arbitrary relational testing.

Note that the B and C stimuli were not presented together as comparisons on any of the more than and less than training tasks. This design removed the possibility that the derived more than and less than relations between the B and C stimuli would emerge in the absence of any controlling function for the sample stimulus. For example, if a subject was trained to select the B2 comparison stimulus rather than the C1 or C2 comparison stimuli in the presence of the less than cue, it is possible that this training would establish B2 in a less than relation to C1 and C2, irrespective of the sample stimulus (i.e., from the subject's perspective, "less than means pick the B2 comparison rather than the C1 or C2 comparisons, and thus B2 must be less than C1 or C2"). Because the current study did not present the B and C stimuli together as comparisons during training, this type of nonsample control could not emerge.

Arbitrary relational testing. When a subject had successfully completed the relational training, he or she was immediately exposed (with no additional instructions) to the arbitrary relational test. During relational testing, each of the 3 subjects was exposed to a 70-trial block that presented each of the seven tasks (one same, three more than, and three less than) 10 times in a quasi-random order without feedback (see Figure 1, Panel 4). The stability criterion required that each subject choose the same, but not necessarily correct, comparison on each task at least nine times out of 10 before proceeding to the next stage of the experiment. The seven tasks were carefully designed to control for a number of factors that may confound the effects of the predicted, derived relations. The more important of these controls will be noted below.

The first task (reading from left to right in Figure 1) tested for the same/B1-C1 relation, and the first more than task tested for the B1-C2 relation. The second more than task was identical to the first more than task, except that the correct C2 stimulus was replaced with N2 (used in training); it was predicted that the pretrained subjects would choose N2, because C1 is the same as, and B2 is less than, B1 (note that a selection of something other than N2 in the presence of the more than cue had been reinforced during training). The third more than task presented the novel stimulus, N5, as both the sample and com-

parison, with B2 as the other remaining comparison; it was predicted that pretrained subjects would choose B2 on this task because the stimulus, N5, cannot be more than itself (note that a performance based on equivalence or exclusion would predict selection of N5). The first less than task tested for the B1-B2 relation. The second less than task was identical to the first, except that the correct B2 stimulus was replaced with N4 (used in training); it was predicted that the pretrained subjects would choose N4, because C1 is the same as, and C2 is more than, B1 (note that a selection of something other than N4 in the presence of the less than cue had been reinforced during training). The third more than task presented the novel stimulus, N6, as both the sample and comparison stimulus, with C2 as the other comparison stimulus; it was predicted that pretrained subjects would choose C2 on this task because the stimulus, N6, cannot be more than itself (note once more that responding based on equivalence or exclusion relations would predict selection of N6).

Note that a large number of same, more than, and less than relational tasks could have been used at this stage to test for these derived relations (cf. Steele & Hayes, 1991). However, the number of tasks was kept to a minimum for the following three reasons: (a) Derived relational responding (in accordance with sameness, difference, and opposition) had already been clearly demonstrated in a previously published study that employed a large number of tasks (Steele & Hayes, 1991), (b) unexpected sources of stimulus control are more difficult to identify as the number of testing tasks increases, and (c) to avoid "overworking" the subjects before the self-discrimination training and testing phases of the experiment, we used only those tasks that were deemed absolutely necessary to demonstrate the predicted derived relations.

Self-Discrimination Training

When subjects had completed the relational training and testing they were exposed to self-discrimination training. Each of the 3 subjects was seated in front of the computer monitor and presented with the following "minimal" instructions (see Dymond & Barnes, 1994) that were read aloud by the experimenter while pointing to the relevant keys:

The computer will present the words "SPACE-BAR TASK" on the computer screen. Whenever you see these words, you must learn how to press the space bar.

After each space-bar pressing task, the computer will present three nonsense syllables at the bottom of the screen. You must learn to select the correct nonsense syllable.

You select the nonsense syllable on the left by pressing the marked key on the left, you select the nonsense syllable in the middle by pressing the marked key in the middle, and you select the syllable on the right by pressing the marked key on the right.

If you have any questions please read the instructions again, and then just "have a go," and see how you get on. The experimenter is not allowed to discuss the experiment with you until after you have completed the entire study.

Instructions were repeated if the subject requested, and any questions were answered by referring the subject to the instructions. A copy of these instructions was left on the table beside the computer.

Three training stages, each consisting of 30 trial blocks, were used to establish self-discrimination responding. Each trial involved two tasks, one presented after the other: (a) a schedule control task and (b) a matching-to-sample task (without a contextual cue). The purpose of the three training stages was to obtain stimulus control by the onscreen stimuli and then remove the onscreen stimuli (in two steps), so that the control transferred to the subject's own behavior. Throughout the three stages of self-discrimination training, feedback (CORRECT or WRONG, and POINTS EARNED) was presented on all schedule control and matching-to-sample tasks.

During the first task of Stage 1 (see Figure 2, Panel 1), a novel nonsense syllable designated "X1" was always presented on the screen (below the words "SPACE-BAR TASK"). If the subject did not emit a response (i.e., did not press the space bar), the X1 stimulus remained onscreen for the duration of the schedule (i.e., 5 s). If the subject made a response, X1 was immediately replaced by the nonsense syllable designated "B1" (i.e., from the relational training and testing stages of the experiment). If the subject made a second response, B1 was immediately replaced by a second novel nonsense

syllable designated "X2." If the subject made a third response, the screen cleared and remained blank for the remainder of the 5-s interval (any further responses produced no stimulus changes on the computer screen, and the WRONG feedback and a reduction in points earned were always presented at the end of the 5-s interval). When subjects had completed Task 1, they were exposed to a matching-to-sample task (Task 2; see Figure 2, Panel 1). In Task 2, the sample was the same stimulus that had been on the screen at the end of the schedule performance task (i.e., X1, B1, or X2); if the subject had emitted three or more responses on Task 1 and had therefore completed the task with a blank screen, no sample was presented during Task 2. The three comparison stimuli were X1, B1, and X2. When X1 was the sample, X1 was the correct comparison stimulus; when B1 was the sample, B1 was the correct comparison stimulus; when X2 was the sample, X2 was the correct comparison stimulus; when no sample was presented, none of the comparison stimuli were correct (i.e., no matter which of the three comparison stimuli the subject chose, it was defined as an incorrect response and thus choosing any of the three stimuli produced the WRONG feedback and a reduction in points). Subjects could produce a correct matching-to-sample response at this stage by means of identity matching, without necessarily discriminating their own schedule performance. If a subject had emitted three or more responses on Task 1, identity matching could not occur because no sample was presented on Task 2. The two tasks were presented in blocks of 30 trials (i.e., Task 1 followed by Task 2 repeated 30 times), and they represented the first stage in establishing self-discrimination functions for X1, B1, and X2.

Stage 2 was identical to Stage 1, except that in Task 2 the matching-to-sample format was modified; no sample was presented above the two comparison stimuli (Figure 2, Panel 2). By not presenting a sample during Task 2, a subject was presented with a delayed identity matching procedure (assuming, of course, that the subject had emitted less than three responses on Task 1). As with Stage 1, subjects could produce a correct matching-to-sample performance on Task 2 without discriminating their own schedule performance.

Stage 3 was identical to Stage 2, except that the stimuli involved in Task 1 were removed. That is, a subject's performance on this task was not accompanied by the appropriate on-screen nonsense syllable. This final modification thus required that the subject discriminate their "no response/one response/two responses" performance on the previous schedule, in order to produce the correct response (i.e., choose the correct nonsense syllable) on Task 2 (see Figure 2, Panel 3). This is the first point at which subjects had to discriminate their preceding schedule performance.

The use of recycling conjunctive schedules for self-discrimination training meant that each schedule terminated after 5 s, and the appropriate feedback was presented, irrespective of a subject's performance. Thus, subjects were simply required to discriminate no response or one response or two responses on the schedule rather than the reinforcement contingency (see Hineline & Wanchisen, 1989). For instance, even if a subject did not emit a response on the recycling conjunctive FT 5-s FR $> 0 < 2$ schedule, and thus WRONG appeared after the 5-s interval, he or she could still successfully discriminate the incorrect schedule performance (i.e., pick X1) and thereby obtain the CORRECT feedback and regain the point lost for the incorrect schedule performance.

Mastery criterion. During training Stages 1 and 2, there was no specific mastery criterion, although, in general, subjects progressed from one stage to the next only when they achieved at least 27 of 30 correct matching-to-sample responses (Task 2) in a given block of 30 trials. During training on Stage 2, if they just failed to reach this criterion (e.g., 25 of 30) they were reexposed to the same stage, but if their performance fell well below criterion (e.g., 18 of 30) they were returned to Stage 1.

A strict mastery criterion of at least 27 of 30 correct matching-to-sample responses within a given block of 30 trials was employed for self-discrimination training Stage 3. If subjects failed to meet this criterion, they were either reexposed to Stage 3 or returned to an earlier stage. No specific criteria were used to decide whether a subject should be retrained on Stage 3 or returned to an earlier stage, although decisions were usually based on how

poorly or well a subject had performed on his or her last exposure (e.g., if a performance approached the 27 of 30 stability criterion, the subject was reexposed to Stage 3, but if it did not he or she was returned to an earlier stage). No explanation or other form of verbal contact between subject and experimenter was allowed during or between these blocks of training trials.

Reexposure to the Relational Test and Self-Discrimination Training

After the self-discrimination training had been successfully completed, the subjects were reexposed to the arbitrary relational test and immediately thereafter to the final stage of self-discrimination training (i.e., Stage 3). These reexposures were used to ensure that the previously established performances were still intact before subjects were exposed to the self-discrimination tests.

Self-Discrimination Tests

Test 1. After subjects had been successfully reexposed to the relational test and to the self-discrimination training, they were immediately exposed to the first self-discrimination test (Figure 2, Panel 4). Test 1 was identical to the final self-discrimination training stage, except for the following two differences. First, the stimuli in Task 2 were the nonsense syllables designated "B2," "C1," and "C2." In this experimental context, it was predicted that (a) C1 would acquire the self-discrimination one-response function of B1 in accordance with the derived relation of sameness (i.e., if B1 and C1 are both the same as A1, then B1 and C1 are the same, so C1 means the same responding as B1), (b) B2 would acquire the self-discrimination no-response function through the derived relations of sameness and less than (e.g., if B1 is the same as A1 and B2 is less than A1, then B2 is less than B1, so B2 means less responding than B1), and (c) C2 would acquire the self-discrimination two-response function through the derived relations of sameness and more than (e.g., if B1 is the same as A1 and C2 is more than A1, then C2 is more than B1, so C2 means more responding than B1). The second difference between the final stage of self-discrimination training and the self-discrimination test was that no feedback was presented on Task 2 during testing. Feedback

("CORRECT" and "WRONG") occurred on Task 1 trials, but the "POINTS EARNED" feedback was omitted, so that subjects did not obtain indirect feedback for their self-discrimination responses on Task 2.

Test 2. This test involved a reversal in the order of presentation of Task 1 and Task 2 (Figure 2, Panel 5). Subjects were first presented with the B2, C1, and C2 stimuli and were required to select the stimulus that corresponded to what they "intended to do" on the following schedule task. Before exposure to Test 2, subjects were simply told, "This time you have to pick a nonsense syllable before the space-bar task." If a subject chose B2 and did not respond on the schedule task, the previous selection of B2 was defined as the correct self-discrimination response. If a subject chose C1 and emitted only one response on the schedule task, the previous selection of C1 was defined as correct. If a subject selected C2 and subsequently emitted two responses on the schedule task, the previous selection of C2 was defined as correct. If a subject selected any of the three stimuli and subsequently emitted three or more responses on the schedule task, the previous selection was always defined as incorrect. In accordance with the previous test, no feedback was presented on the nonsense syllable choice task (i.e., Task 1 in Test 2), and although feedback occurred on the schedule control task (i.e., Task 2 in Test 2), the "POINTS EARNED" feedback was omitted.

RESULTS AND DISCUSSION

The results are shown in Figures 3 and 4. Subject 1 (Figure 3) required 180 trials of arbitrary relational training. On her first exposure to the relational test, she failed to produce a consistent performance (i.e., choose the same, but not necessarily correct, comparison on each of the seven tasks at least nine times out of 10). She was reexposed to the same/opposite and more than/less than nonarbitrary relational pretraining and then to the arbitrary relational training (60 trials), but she again failed to produce a consistent performance on the relational test. However, after another 60 arbitrary relational training trials, she produced 65 correct responses out of 70 on the relational test (never falling below nine correct responses on each of the seven tasks). This subject then required four ex-

posures to self-discrimination training Stage 1, three exposures to Stage 2, and three exposures to Stage 3. At this point she was successfully retested on the relational test and was retrained on self-discrimination training Stage 3 (to ensure that the behavioral relations necessary for the predicted transformation of functions were still intact). She then demonstrated the predicted transformation of self-discrimination response functions on self-discrimination Tests 1 and 2 (no response, choose B2; respond once, choose C1; respond twice, choose C2).

Subject 2 (Figure 3) required eight separate exposures to the relational training and testing (and two separate reexposures to the nonarbitrary relational pretraining) before he produced a consistent (and correct) performance. This subject then required six exposures to self-discrimination training Stage 1, two exposures to Stage 2, and one exposure to Stage 3. He was successfully retested on the relational test and was retrained on self-discrimination Stage 3 before showing the predicted transformation of self-discrimination response functions on Tests 1 and 2.

Subject 3 (Figure 4) required five separate exposures to the relational training and testing before he produced a consistent (and incorrect) performance. For example, in the presence of same and B1 he consistently, and correctly, chose C1, but in the presence of more than and B1 he consistently, but incorrectly, chose C1. The remaining parts of his final performance were as follows: more than/B1-B2 (incorrect), more than/N5-N5 (incorrect), less than/B1-C1 (incorrect), less than/B1-C2 (incorrect), less than/N6-C2 (correct). This subject then required one exposure to self-discrimination training Stage 1, three exposures to Stage 2, and one exposure to Stage 3. When he was reexposed to the relational test, he again produced a consistent, but incorrect, performance identical to that produced during his previous exposure. After successful retraining on self-discrimination Stage 3, he was exposed to self-discrimination Tests 1 and 2, and as predicted he failed to transform the self-discrimination response functions in accordance with the relations of sameness, more than, and less than (i.e., during Test 1 he chose B2 five times out of 12, C1 six times out of nine, and C2 four times out of nine after emitting zero, one,

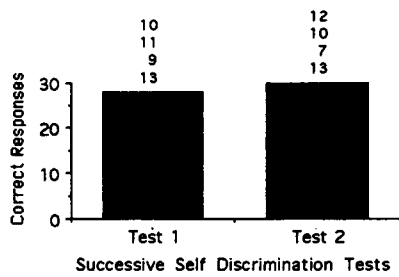
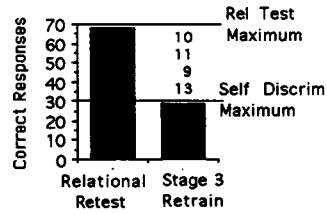
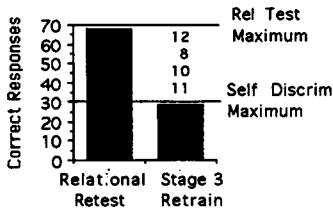
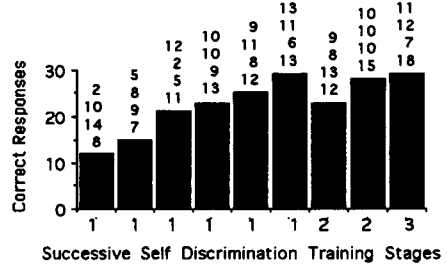
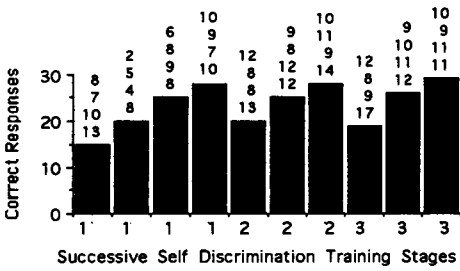
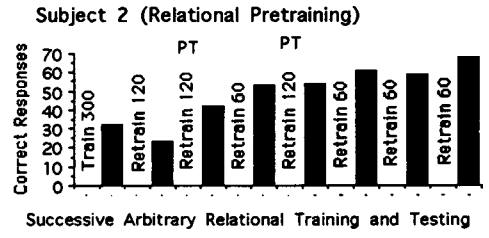
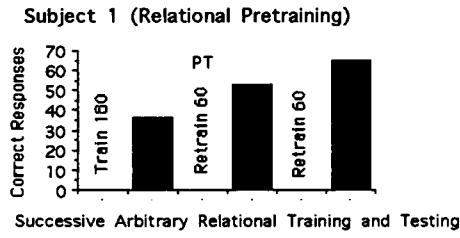

Fig. 3. Experiment 1. Results of arbitrary relational training and testing and self-discrimination training and testing for relationally pretrained Subjects 1 and 2. Panel 1 (top): "Train —" indicates the number of training trials presented during a subject's first exposure to the arbitrary relational training. "Retrain —" indicates the number of training trials presented during all subsequent exposures to these training phases. "PT" indicates that the subject was reexposed to the same/opposite and more than/less than pretraining before being retrained on the arbitrary relations. Panels 2, 3, and 4 (vertically): The numbers above each column for the self-discrimination training and testing stages provide information regarding the subjects' performances across each block of 30 schedule performance trials. The three upper numbers show the number of trials on which the subject did not respond (top), responded once (second from top), and responded twice (third from top); the bottom figure indicates the number of schedule tasks correctly completed. Note that the three upper numbers may not sum to 30, because on some schedule-performance trials a subject may have produced three or more responses.

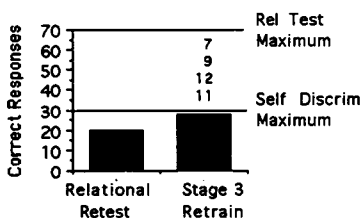
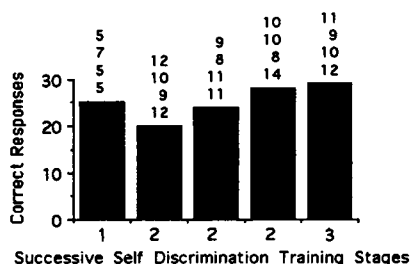
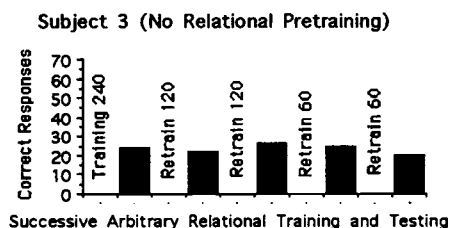

Fig. 4. Experiment 1. Results of arbitrary relational training and testing and self-discrimination training and testing for the nonrelationally pretrained Subject 3 (see caption to Figure 3 for details).

and two responses, respectively; during Test 2 he chose B2 three times out of nine, C1 five times out of 13, and C2 three times out of eight before emitting zero, one, and two responses, respectively).

In summary, these data suggest that without relational pretraining, the predicted transformation of self-discrimination response functions in accordance with sameness, more than, and less than relations is un-

likely to emerge. In effect, because the nonpretrained subject failed to show the transformed performances, it is unlikely that the transformation emerged in the pre-trained subjects purely on the basis of unexpected stimulus control that developed independently of the pretraining.

EXPERIMENT 2

Two major criticisms may be made of Experiment 1. First, only 3 subjects were used, and 1 of these was a control subject (i.e., only two subjects showed the predicted transformation of self-discrimination response functions). A more robust demonstration of the transformation effect would require that a similar effect be demonstrated using additional subjects. Experiment 2 therefore attempted to replicate, using 2 naive subjects, the transformation of self-discrimination response functions in accordance with sameness, more than, and less than relations.

The second criticism of Experiment 1 is that the arbitrary training and testing did not clearly demonstrate contextual control in accordance with sameness. Specifically, subjects were trained to pick B1 and C1 in the presence of A1 and the same contextual cue, and thus subjects could have ignored the sample (A1) and formed a simple equivalence relation with the same cue as the mediating node (i.e., $B1 \leftarrow \text{same} \rightarrow C1$). Consequently, the arbitrary relational test, in which the subjects chose C1 given B1 in the presence of the same cue, cannot determine whether subjects were responding in accordance with a simple equivalence relation or a contextually controlled relation of sameness. It also follows, therefore, that the trained self-discrimination one-response function of B1 could have emerged for C1 in accordance with a simple equivalence relation or a contextually controlled sameness relation. To circumvent this interpretive problem, Experiment 2 incorporated an additional two tasks into the arbitrary relational training and an additional two tasks into the arbitrary relational testing. The details of these additional tasks and the rationale for using them are as follows.

During the relational training the subjects were presented with the original six training tasks from Experiment 1 and the following two additional tasks: [same] Y1/B1-Z1 and

[same] Y1/C1-Z2. In effect, subjects were trained, in the presence of same, to choose the comparisons Z1 and Z2 given the sample Y1. Incorporating these two additional training tasks ensured that choosing B1 and C1 in the presence of same was reinforced on some trials but not on others. This pattern of training should thereby prevent the same cue from functioning as a mediating node for a simple equivalence relation between B1 and C1.

During the relational test, the subjects were presented with the original seven testing tasks from Experiment 1 and the following two tasks: [same] B2/C1-B2-C2 and [same] C2/B1-B2-C2. If the same stimulus functions as a contextual cue (for sameness responding) during the relational test, subjects should choose the B2 comparison in the presence of the B2 sample and should choose the C2 comparison in the presence of the C2 sample (note that during training, choosing B2 or C2 is always incorrect in the presence of the same cue). In effect, if same functions as a contextual cue, it should control selection of a comparison that is physically identical to the sample, even if choosing that comparison has always resulted in nonreinforcement during previous training.

Experiment 2 employed the same tasks that were used in Experiment 1 for training and testing the more than and less than relations (i.e., no additional more than or less than tasks were included). No changes were deemed necessary for the following reason. Although during training subjects may have picked B2 and C2 in the presence of the more than and less than cues (i.e., treating them as samples rather than as contextual cues), passing the relational test required that subjects show unequivocal contextual control. Specifically, if the subjects responded to the contextual cues as samples during the relational training, the following two simple equivalence classes would have emerged: same-B1-C1 and more than-less than-B2-C2 (note that choosing both B2 and C2 was reinforced in the presence of both more than and less than; thus, one class containing both cues would form). If these equivalence classes had emerged, subjects should have continued to choose B2 and C2 on all of the test trials in the presence of the more than and less than cues. This, however, did not happen. In

fact, on two separate tasks the pretrained subjects chose a stimulus that had always been incorrect during training, although B2 was available on one of the tasks and C2 was available on the other (see Figure 1, and reading from left to right, compare Tasks 5 and 6 from the relational training with Tasks 3 and 6 from the relational test). Finally, and perhaps more importantly, if only two equivalence classes had emerged during the relational training and testing, there would be no basis for predicting the transformation of three self-discrimination response functions. (This is a complex issue, and we will return to it in the General Discussion.)

METHOD

Subjects, Apparatus, and Materials

Two subjects, 1 male (19 years old) and 1 female (21 years old), participated in Experiment 2. Both subjects were nonpsychology undergraduates, attending University College Cork. Neither of the subjects had any knowledge of stimulus equivalence or relational frame theory. Payment for participation and all other arrangements were identical to those in Experiment 1. The apparatus and materials were identical to those in Experiment 1.

Procedure

Subjects 4 and 5 attended five to nine separate sessions, each lasting between 30 min and 2 hr. The nonarbitrary relational pre-training, self-discrimination training, and self-discrimination tests were identical to those used in Experiment 1. The arbitrary relational training and testing employed the same tasks as Experiment 1, but an additional two tasks were added to the training and testing phases, respectively (see Figure 1, Panels 3 and 4). The two additional training tasks were [same] Y1/B1-Z1 and [same] Y1/C1-Z2 (Y1, Z1, and Z2 were three-letter nonsense syllables). Choosing Z1 on the former task and choosing Z2 on the latter always produced the CORRECT feedback (choosing B1 and C1, respectively, always produced the WRONG feedback). During relational training, the eight tasks were presented in a quasi-random order within blocks of 80 trials (i.e., 10 exposures to each task within each 80-trial

block). Both subjects were required to produce a minimum of nine correct responses out of 10 on each of the eight tasks, within an 80-trial block, before proceeding to the arbitrary relational testing.

The two additional tasks that were included in the arbitrary relational test (from Experiment 1) examined the same/B2-B2 relation and the same/C2-C2 relation. During relational testing, the nine tasks were presented within a 90-trial block, with each of the nine tasks presented 10 times in a quasi-random order without feedback (see Figure 1, Panel 4). The stability criterion required that each subject choose the same, but not necessarily correct, comparison stimulus on each task at least nine times out of 10 before proceeding to the next stage of the experiment (i.e., to the self-discrimination training that was identical to Experiment 1).

RESULTS AND DISCUSSION

The results are shown in Figure 5, using the same format that was used in Figures 3 and 4. Subject 4 required 480 trials of arbitrary relational training. On his first exposure to the relational test, he failed to produce a consistent performance (i.e., choose the same, but not necessarily correct, comparison on each of the nine tasks at least nine times out of 10). He was reexposed to the same/opposite and more than/less than nonarbitrary relational pretraining and then to the arbitrary relational training (160 trials), but he again failed to produce a consistent performance on the relational test. After another 80 relational training trials, he produced 87 correct responses out of 90 on the relational test (never falling below nine correct responses on each of the nine tasks). This subject then required three exposures to self-discrimination training Stage 1, three exposures to Stage 2, and three exposures to Stage 3. At this point he was retested on the relational test and was retrained on self-discrimination training Stage 3. However, he failed to produce a stable performance on the relational test when he selected C1 eight times out of 10 in the presence of the B1 sample and the same cue (i.e., if he had chosen C1 nine times he would have passed the test), and produced only 26 correct responses on the self-discrimination training (a minimum of 27 correct was required). He was immediately

reexposed to the relational test and self-discrimination training and completed both successfully. He then demonstrated the predicted transformation of self-discrimination response functions on self-discrimination Tests 1 and 2 (no response, choose B2; respond once, choose C1; respond twice, choose C2).

Subject 5 required five separate exposures to the relational training and testing and two separate reexposures to the nonarbitrary relational pretraining before she produced a consistent (and correct) performance. This subject then required three exposures to self-discrimination training Stage 1, two exposures to Stage 2, and two exposures to Stage 3. She was successfully retested on the relational test and was retrained on self-discrimination Stage 3 before showing the predicted transformation of self-discrimination response functions on self-discrimination Tests 1 and 2.

These data support and extend the findings of Experiment 1, in that an additional 2 subjects produced a transformation of self-discrimination response functions in accordance with the arbitrarily applicable relations of sameness, more than, and less than. Furthermore, in Experiment 2 (a) subjects were trained to select and reject B1 and C1 in the presence of the same cue, and (b) on two separate relational testing tasks, in the presence of same subjects chose comparison stimuli (B2 and C2) that were physically identical to the samples on those tasks, even though they had been trained to choose stimuli other than those comparison stimuli in the presence of the same cue. It is highly unlikely, therefore, that subjects ignored the A1 stimulus during training (and responded to the same cue as a sample) and thereby formed a simple equivalence relation between the B1 and C1 stimuli.

GENERAL DISCUSSION

Experiments 1 and 2 demonstrated that subjects' self-discrimination response functions established on three schedules of reinforcement can be transformed in accordance with the arbitrarily applicable relations of sameness, more than, and less than. It is important to note that (a) both experiments employed a predetermined stability criterion during the relational testing (i.e., consistent

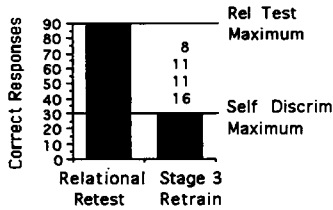
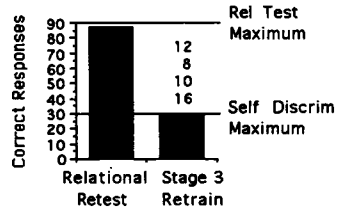
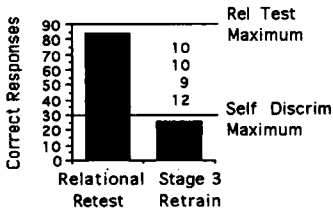
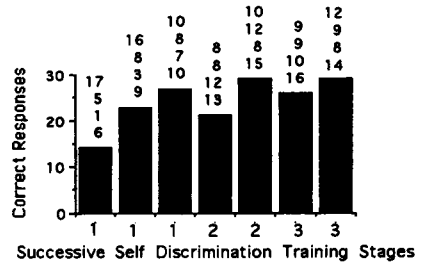
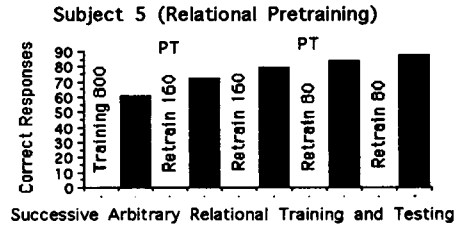
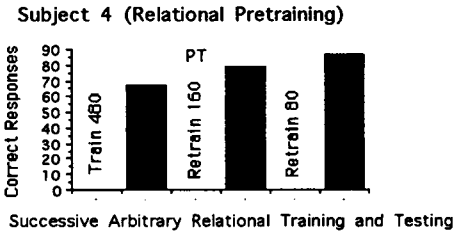

Fig. 5. Experiment 2. Results of arbitrary relational training and testing and self-discrimination training and testing for relationally pretrained Subjects 4 and 5 (see caption to Figure 3 for details).

but not necessarily correct), and (b) all of the experimental subjects showed a transformation of functions during their first exposure to the self-discrimination tests. It is very likely, therefore, that the predicted performances were largely derived from the trained relations and not from the additional feedback provided by repeated training and testing that is often employed in transfer-of-function procedures (see Barnes & Keenan, 1993b, p. 63).

These data clearly support and extend the work of those researchers who have examined derived relations other than equivalence (e.g., Barnes & Keenan, 1993b; Green et al., 1993; Steele & Hayes, 1991). The most important feature of the current study in this respect is the first demonstration of relational responding (using matching-to-sample and self-discrimination procedures) in accordance with the three derived relations of sameness, more than, and less than. The present findings also extend our previous research on transfer of self-discrimination response functions (e.g., Dymond & Barnes, 1994) in which we showed the derived transfer effect through equivalence relations both with regard to prior (Test 1) and subsequent (Test 2) schedule performance.

Although all 4 pretrained subjects in the current study demonstrated the predicted transformation of self-discrimination response functions on their first exposure to the self-discrimination tests, it is interesting that these subjects showed the predicted performances on the arbitrary relational tests only after repeated training and testing. A similar effect has also been reported in a number of stimulus equivalence and transfer-of-function studies, in which subjects produced the predicted, untaught performances only after repeated training, testing, or both (e.g., Barnes & Keenan, 1993b; Devany, Hayes, & Nelson, 1986; but see Barnes, McCullagh, & Keenan, 1990). Exactly why derived responding often emerges in this way remains at present unclear, although recent stimulus equivalence research has found that training and testing for symmetry relations before training and testing for more complex relations (e.g., combined symmetry and transitivity) appears to reduce the need for recursive training and testing (Fields, Adams, Newman, & Verhave, 1992). Within the con-

text of the current study, therefore, the gradual emergence of the predicted performances may have been related to the fact that subjects were trained and tested on same, more than, and less than tasks within single blocks. If during Experiment 2, for example, subjects had been trained and tested on the four same tasks, then trained and tested on the more than tasks, and then finally trained and tested on the less than tasks, the emergence of the untaught performances may have occurred more rapidly than it did. Future studies in this area could certainly examine this possibility.

The current study showed a transformation effect that does not lend itself easily to an interpretation based on equivalence. Specifically, 4 subjects showed that when a one-response self-discrimination function had been related to the B1 stimulus, this function could be transformed in accordance with the relations of more than and less than. A no-response (less than one response) function was established for B2, and a two-response (more than one response) function was established for C2. It is difficult to predict this outcome in terms of equivalence relations because (a) two different response functions emerged for B2 and C2, and (b) both of these functions differed from the trained B1 function. An equivalence-based interpretation would require the existence of three separate equivalence relations (i.e., one for each function) or, alternatively, just one equivalence relation in which the function transformation was controlled, in part, by the nodal distances between the stimuli participating in the relation (see Fields, Adams, & Verhave, 1993). Both of these interpretations seem unlikely, however, because (a) the mere existence of three separate equivalence relations would not produce the specific transformation of functions seen here (i.e., even if B1, B2, and C2 were members of three different equivalence relations, establishing a one-response function for B1 leaves the derived functions of B2 and C2 unspecified), and (b) B2 and C2 were both removed by one node (i.e., A1) from the B1 stimulus, and thus nodal distance does not differentiate between these stimuli. At the very least, these findings suggest that there are derived relations that cannot be captured by the language of equivalence alone, and that future empirical and theoretical research

should examine extensions of, or perhaps alternatives to, the concept of stimulus equivalence (see Barnes, 1994; Barnes & Holmes, 1991; Green et al., 1993; Hayes, 1991; Stromer, McIlvane, & Serna, 1993; Watt, Keenan, Barnes, & Cairns, 1991).

One alternative to the concept of stimulus equivalence that appears to describe the current data adequately is the relational frame account. We have used relational frame terminology to describe the current procedures and findings and those reported in our previous study (see Dymond & Barnes, 1994, for a detailed discussion of our reasons for adopting the language of relational frame theory). Interestingly, however, other researchers have also been exploring alternatives to, or extensions of, the language of equivalence; thus, we will briefly consider whether these alternatives and extensions can account for the current data.

One recent alternative to the language of stimulus equivalence is the concept of separable stimulus compound suggested by Stromer et al. (1993). Specifically, these researchers have argued that the behavioral control referred to as stimulus equivalence is not necessarily hierarchical (i.e., equivalence does not necessarily involve control by a four-term contingency). In effect, each stimulus participating in an equivalence relation may be conceptualized as an element of a separable compound; thus, selecting the "correct" comparison in the presence of a sample may reflect control by a three-term contingency in which two elements of a separable compound (e.g., A1 and B1) are treated as a *single* discriminative stimulus (i.e., A1B1). Although the separable compound interpretation appears to offer an adequate language for describing stimulus equivalence and perhaps other related effects (e.g., Markham & Dougher, 1993), it is not clear that the concept of a separable compound can readily describe the transformation of stimulus functions through the relations of more than and less than observed in the current study. Let us assume that establishing a particular function for one element of a separable compound may also establish the same function for the remaining elements (see Stromer et al., 1993, p. 593). In the current study, training a no-response function for the novel stimulus X1, a one-response function for B1, and

a two-response function for the novel stimulus X2 produced a no-response function for B2, a one-response function for C1, and a two-response function for C2. We might consider B1 and C1 as elements of a separable compound that was established by the arbitrarily applicable relational training and testing (i.e., same-A1-B1 and same-A1-C1 established the four-element compound, same-A1-B1-C1; see Markham & Dougher, 1993). However, it is most unlikely that B2 was compounded with X1 and C2 was compounded with X2 because X1 and X2 were not used at any stage during the relational training and testing. Thus, we cannot predict that a no-response function will emerge for B2 and a two-response function will emerge for C2. We must conclude, therefore, that the concept of separable compound cannot adequately describe the current data.

One area of research that has extended the phenomenon of stimulus equivalence and may offer an adequate interpretation of the current findings is the investigation of stimulus sequences (e.g., Green et al., 1993). These sequences are sometimes examined by training subjects in a series of overlapping two-choice sequence responses, in which pairs of stimuli are presented. For example, on some trials choosing Stimulus A1 and then Stimulus A2 is reinforced, and on other trials choosing A2 and then A3 is reinforced. A total of four sequence responses may be explicitly trained in this way (i.e., $A1 \rightarrow A2$, $A2 \rightarrow A3$, $A3 \rightarrow A4$, $A4 \rightarrow A5$) before the subject is tested for a derived order relation (i.e., no feedback) using various combinations of the five stimuli. Demonstration of a derived order relation requires that the subject's test performance complies with the four properties of irreflexivity, asymmetry, transitivity, and connectedness. Irreflexivity requires that the subject must not choose the same stimulus twice in a given sequence (e.g., $A1 \rightarrow A1$ is incorrect); asymmetry requires that the subject must not reverse any of the trained sequences during test trials (e.g., $A2 \rightarrow A1$ is incorrect); transitivity requires that the subject must respond in accordance with the order relation when presented with pairs of stimuli that were not presented together during training (e.g., $A2 \rightarrow A4$); connectedness requires that the subject must respond in accordance with the order relation given all possible combinations of the stimuli used

during training (e.g., $A1 \rightarrow A5$, $A1 \rightarrow A3 \rightarrow A5$).

The important issue in the context of the current study is that the order relation and the relations of more than and less than appear to possess similar properties. The relations of more than and less than are (a) irreflexive (i.e., a stimulus cannot be more or less than itself), (b) asymmetrical (e.g., if A1 is more than A2, then A2 is not more than A1), (c) transitive (e.g., if A1 is more than A2 and A2 is more than A3, then A1 is more than A3), and (d) connected (i.e., all stimuli that participate in a specific more than or less than relation are, ipso facto, related to each other, and the relation is therefore connected).

Given that order and more than/less than relations appear to have similar defining properties, can we interpret the current findings in terms of an order relation? Clearly, such an interpretation would be difficult because no sequence responses were explicitly trained in this study. Consequently, it appears once more that the relational frame terminology most adequately describes the current data. Furthermore, according to the relational frame account, order and more than/less than relations are subcategories of the relational frame of "comparison" (see Hayes, 1991, p. 30); thus, the relational frame account can accommodate, at least theoretically, both the current data and the derived order relations that emerge from stimulus sequence training.

Clearly, future empirical research will need to examine more closely the derived relations of more than and less than and their possible involvement in other types of derived relational responding. For example, it remains to be seen whether it is possible to replicate the transformation of self-discrimination response functions seen in the present study using an order relation instead of the more than/less than relations (e.g., train the sequence $A1 \rightarrow A2 \rightarrow A3$, train a one-response function to A2, and finally test for a no-response function for A1 and a two-response function for A3).

Conclusion

The language of relational frame theory appears to provide the most adequate description of the current findings. Of course,

considerable research is required before its value as a descriptive and explanatory tool can be firmly established. For example, the effects, if any, of learning to respond in accordance with one type of relation on other types of relational responding remain to be investigated (e.g., does learning to respond in accordance with the relations of more than and less than affect learning about order relations, or vice versa?). Clearly, these and related questions should generate important experimental and conceptual analyses for some time to come.

REFERENCES

- Barnes, D. (1994). Stimulus equivalence and relational frame theory. *The Psychological Record*, *44*, 91-124.
- Barnes, D., Browne, M., Smeets, P. M., & Roche, B. (1995). A transfer of functions and a conditional transfer of functions through equivalence relations in three to six year old children. *The Psychological Record*, *45*, 405-430.
- Barnes, D., & Hampson, P. J. (1993). Stimulus equivalence and connectionism: Implications for behavior analysis and cognitive science. *The Psychological Record*, *43*, 617-638.
- Barnes, D., & Holmes, Y. (1991). Radical behaviorism, stimulus equivalence, and human cognition. *The Psychological Record*, *41*, 19-31.
- Barnes, D., & Keenan, M. (1989). Instructed human fixed-interval performance: The effects of the experimental setting. *The Psychological Record*, *39*, 351-364.
- Barnes, D., & Keenan, M. (1993a). Concurrent activities and instructed human fixed-interval performance. *Journal of the Experimental Analysis of Behavior*, *59*, 501-521.
- Barnes, D., & Keenan, M. (1993b). A transfer of functions through derived arbitrary and nonarbitrary stimulus relations. *Journal of the Experimental Analysis of Behavior*, *59*, 61-81.
- Barnes, D., & Keenan, M. (1994). Response-reinforcer contiguity and human performance on simple time-based reinforcement schedules. *The Psychological Record*, *44*, 63-90.
- Barnes, D., McCullagh, P. D., & Keenan, M. (1990). Equivalence class formation in non-hearing impaired children and hearing impaired children. *The Analysis of Verbal Behavior*, *8*, 19-30.
- Cullinan, V. A., Barnes, D., Hampson, P. J., & Lyddy, F. (1994). A transfer of explicitly and non-explicitly trained sequence responses through equivalence relations: An experimental demonstration and connectionist model. *The Psychological Record*, *44*, 559-585.
- de Rose, J. C., McIlvane, W. J., Dube, W. V., Galpin, V. C., & Stoddard, L. T. (1988). Emergent simple discrimination established by indirect relation to differential consequences. *Journal of the Experimental Analysis of Behavior*, *50*, 1-20.
- de Rose, J. C., McIlvane, W. J., Dube, W. V., & Stoddard, L. T. (1988). Stimulus class formation and functional equivalence in moderately retarded individuals' con-

- ditional discrimination. *Behavioral Processes*, 17, 167-175.
- Devany, J. M., Hayes, S. C., & Nelson, R. O. (1986). Equivalence class formation in language-able and language-disabled children. *Journal of the Experimental Analysis of Behavior*, 46, 243-257.
- Dymond, S., & Barnes, D. (1994). A transfer of self-discrimination response functions through equivalence relations. *Journal of the Experimental Analysis of Behavior*, 62, 251-267.
- Fields, L., Adams, B. J., Newman, S., & Verhave, T. (1992). Interactions among emergent relations during equivalence class formation. *The Quarterly Journal of Experimental Psychology*, 45B, 125-138.
- Fields, L., Adams, B. J., & Verhave, T. (1993). The effects of equivalence class structure on test performances. *The Psychological Record*, 43, 697-712.
- Gatch, M. B., & Osborne, J. G. (1989). Transfer of contextual stimulus function via equivalence class development. *Journal of the Experimental Analysis of Behavior*, 51, 369-378.
- Green, C., Stromer, R., & Mackay, H. A. (1993). Relational learning in stimulus sequences. *The Psychological Record*, 43, 599-615.
- Hayes, S. C. (1991). A relational control theory of stimulus equivalence. In L. J. Hayes & P. N. Chase (Eds.), *Dialogues on verbal behavior: The first international institute on verbal relations* (pp. 19-40). Reno, NV: Context Press.
- Hayes, S. C., Devany, J. M., Kohlenberg, B. S., Brownstein, A. J., & Shelby, J. (1987). Stimulus equivalence and the symbolic control of behavior. *Revista Mexicana de Analisis de la Conducta*, 13, 361-374.
- Hayes, S. C., Kohlenberg, B. S., & Hayes, L. J. (1991). The transfer of specific and general consequential functions through simple and conditional equivalence relations. *Journal of the Experimental Analysis of Behavior*, 56, 119-137.
- Hayes, S. C., & Wilson, K. G. (1993). Some applied implications of a contemporary behavior-analytic view of verbal events. *The Behavior Analyst*, 16, 283-301.
- Hineline, P. N., & Wanchisen, B. A. (1989). Correlated hypothesizing and the distinction between contingency-shaped and rule-governed behavior. In S. C. Hayes (Ed.), *Rule governed behavior: Cognition, contingencies, and instructional control* (pp. 221-268). New York: Plenum.
- Kohlenberg, B. S., Hayes, S. C., & Hayes, L. J. (1991). The transfer of contextual control over equivalence classes through equivalence classes: A possible model of social stereotyping. *Journal of the Experimental Analysis of Behavior*, 56, 505-518.
- Markham, M. R., & Dougher, M. J. (1993). Compound stimuli in emergent stimulus relations: Extending the scope of stimulus equivalence. *Journal of the Experimental Analysis of Behavior*, 60, 529-542.
- Steele, D., & Hayes, S. C. (1991). Stimulus equivalence and arbitrarily applicable relational responding. *Journal of the Experimental Analysis of Behavior*, 56, 519-555.
- Stromer, R., McIlvane, W. J., & Serna, R. W. (1993). Complex stimulus control and equivalence. *The Psychological Record*, 43, 585-598.
- Watt, A., Keenan, M., Barnes, D., & Cairns, E. (1991). Social categorization and stimulus equivalence. *The Psychological Record*, 41, 33-50.
- Wulfert, E., & Hayes, S. C. (1988). Transfer of a conditional ordering response through conditional equivalence classes. *Journal of the Experimental Analysis of Behavior*, 50, 125-144.

Received June 7, 1993

Final acceptance April 12, 1995