

A Very Simple Strategy for High-Quality Performance of AC Machines Using Model Predictive Control

Margarita Norambuena ¹, Member, IEEE, Jose Rodriguez ², Fellow, IEEE, Zhenbin Zhang ³, Member, IEEE, Fengxiang Wang ⁴, Member, IEEE, Cristian Garcia ⁵, Member, IEEE, and Ralph Kennel, Senior Member, IEEE

Abstract—This paper presents a new and very simple strategy for torque and flux control of ac machines. The method is based on model predictive control and uses one cost function for the torque and a separate cost function for the flux. This strategy introduces a drastic simplification, achieving a very fast dynamic behavior in the controlled machines. Experimental results obtained with an induction machine confirm the drive's very good performance.

Index Terms—Drives, power electronics, predictive control.

I. INTRODUCTION

THE control of electrical machines has been one of the most classical and challenging problems of electrical engineering.

With the explosive development observed in electromobility in the last decade, the control of electrical machines is of the highest interest for industry today.

Two strategies are widely accepted as standard solutions for high-performance ac drives: field oriented control (FOC) and direct torque control (DTC). FOC was invented in 1972 [1], [2] and DTC was invented in 1986 [3], [4]. These strategies were developed more than 30 years ago, at a time where modern microprocessors were not available. Microprocessors have since been used to improve the performance of these strategies without introducing significant changes in the basic concepts of the theories.

Manuscript received November 28, 2017; revised January 30, 2018; accepted February 22, 2018. Date of publication March 9, 2018; date of current version November 19, 2018. This work was supported in part by Comisión Nacional de Investigación Científica y Tecnológica/Fondo Nacional de Desarrollo Científico y Tecnológico Research Project 1170167, Alexander von Humboldt-Stiftung, and in part by National Natural Science Funds of China under Grant 51507172. Recommended for publication by Associate Editor J. Zhang. (Corresponding author: Margarita Norambuena GAE.)

M. Norambuena is with Facultad de Ingeniería, Universidad Andres Bello, Santiago 7500971, Chile (e-mail: margarita.norambuena@gmail.com).

J. Rodriguez and C. Garcia is with Universidad Andres Bello, Santiago 7500971, Chile (e-mail: jose.rodriguez@unab.cl; cristian.garcia@unab.cl).

Z. Zhang is with the School of Electrical Engineering, Shandong University, Jinan 250061, China (e-mail: zbz@sdu.edu.cn).

F. Wang is with Quanzhou Institute of Equipment Manufacturing, Haixi Institutes, Chinese Academy of Sciences, Jinjiang 362200, China (e-mail: fengxiang.wang@fjirms.ac.cn).

R. Kennel is with the Technische Universitaet Muenchen, München 80333, Germany (e-mail: ralph.kennel@tum.de).

Color versions of one or more of the figures in this paper are available online at <http://ieeexplore.ieee.org>.

Digital Object Identifier 10.1109/TPEL.2018.2812833

However, the tremendous calculation power available today at high speeds and reduced costs makes it possible to develop different control strategies. In effect, model predictive control is one of these modern control strategies that use microprocessors' calculation power differently in the field of power electronics [5]–[15]. Up to now, the finite control set model predictive control (FCS-MPC) of torque and flux of ac machines has been done mainly using a single cost function with a weighting factor to give more importance to one of these control objectives [16]–[18].

The calculation of the weighting factor has been one of the control strategy's important challenges. In most cases, the weighting factor is obtained by a trial and error process that is not easy or elegant, nor is it acceptable for many users [13]–[15], [19]–[23].

This paper presents a new strategy for predictive torque and flux control of ac machines that does not use weighting factors. This strategy is called sequential model predictive control (SMPC), and it uses a sequential structure with a single cost function for each control objective in the system. The first stage controls the torque, and the second stage is dedicated to controlling the flux. The resulting strategy solves, in a very simple and logical way, all the problems and difficulties related to the calculation of the weighting factors.

The following sections of the paper will present the mathematical models for the machine and the inverter, the prediction equations, the control strategy, and the experimental results obtained with an induction machine (IM).

II. MATHEMATICAL MODELS

A. Power Inverter

The inverter used in this work is the two-level voltage source inverter (2L-VSI). Fig. 1 shows the power circuit of the 2L-VSI. This inverter is the simplest and most mature power inverter technology; it has only two power switches for each output leg that work complementarily, but it generates a large harmonic content. However, as the focus of this work is the control strategy, this simple inverter is used.

Fig. 2 shows the possible voltage vectors generated by the 2L-VSI. There are eight possible voltage vectors described in

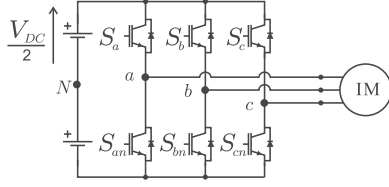

Fig. 1. Power circuit of the 2L-VSI.

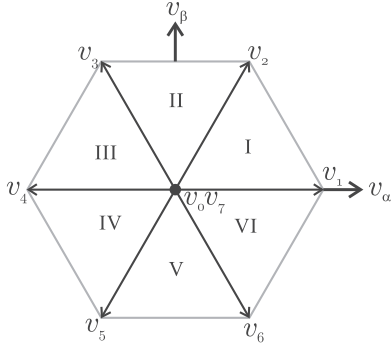

Fig. 2. Vectors of the three-phase 2L-VSI.

 TABLE I
 POSSIBLE SWITCHING STATES OF THREE-PHASE 2L-VSI

	Switching State			Voltage Vector	
	S_A	S_B	S_C	v_α	v_β
v_0	0	0	0	0	0
v_1	1	0	0	$2V_{DC}/3$	0
v_2	1	1	0	$V_{DC}/3$	$\sqrt{3}V_{DC}/3$
v_3	0	1	0	$-V_{DC}/3$	$\sqrt{3}V_{DC}/3$
v_4	0	1	1	$-2V_{DC}/3$	0
v_5	0	0	1	$-V_{DC}/3$	$-\sqrt{3}V_{DC}/3$
v_6	1	0	1	$V_{DC}/3$	$-\sqrt{3}V_{DC}/3$
v_7	1	1	1	0	0

Table I, and vectors v_0 and v_7 are the null voltage vectors ($v_\alpha = 0$; $v_\beta = 0$).

The mathematical equations that describe the 2L-VSI are as follows:

$$v_a = S_a \frac{V_{DC}}{2} \quad (1)$$

$$v_b = S_b \frac{V_{DC}}{2} \quad (2)$$

$$v_c = S_c \frac{V_{DC}}{2}. \quad (3)$$

The voltage in $\alpha - \beta$ frame can be written as follows:

$$\begin{bmatrix} v_\alpha \\ v_\beta \end{bmatrix} = \frac{2}{3} V_{DC} \begin{bmatrix} 1 & -0.5 & -0.5 \\ 0 & \sqrt{3}/2 & -\sqrt{3}/2 \end{bmatrix} \begin{bmatrix} S_a \\ S_b \\ S_c \end{bmatrix}.$$

B. Model of the IM

To generate the mathematical model of the IM, the stator flux Ψ_s and stator current \mathbf{i}_s are taken as state variables. The dynamic equations of IM can be expressed in a stationary frame as follows [24], [25]:

$$\mathbf{v}_s = R_s \mathbf{i}_s + \frac{d\Psi_s}{dt} \quad (4)$$

$$0 = R_r \mathbf{i}_r + \frac{d\Psi_r}{dt} - j\frac{\omega}{p} \Psi_r \quad (5)$$

$$\Psi_s = L_s \mathbf{i}_s + L_m \mathbf{i}_r \quad (6)$$

$$\Psi_r = L_m \mathbf{i}_s + L_r \mathbf{i}_r \quad (7)$$

$$T = \frac{3}{2} p |\Psi_s \otimes \mathbf{i}_s| \quad (8)$$

$$J \frac{d\omega}{dt} = T - T_L \quad (9)$$

where \mathbf{v}_s is the voltage vector, ω denotes the rotor angular speed, p is the pair of poles, and R_s and R_r are the stator and rotor resistance, respectively. L_s , L_r , and L_m are the stator, rotor, and mutual inductance, respectively. Finally, T and T_L are the electrical torque and load torque, respectively.

III. EQUATIONS FOR PREDICTION

For prediction of torque and flux [8], [14], [20], estimation of the stator flux Ψ_s and the rotor flux Ψ_r are required at the present sampling time k .

The rotor flux can be calculated using the equivalent equation of the rotor dynamics of an IM in rotating reference frame aligned with the rotor winding, which gives

$$\Psi_r + \tau_r \frac{d\Psi_r}{dt} = L_m \mathbf{i}_s \quad (10)$$

where $\tau_r = L_r/R_r$ is the rotor time constant. Using the backward-Euler discretization and considering T_s as the sampling time, the discrete-time equation for the rotor flux estimation is as follows:

$$\Psi_r^k = L_m \frac{T_s}{\tau_r} \mathbf{i}_s^{k-1} + \left(1 - \frac{T_s}{\tau_r}\right) \Psi_r^{k-1}. \quad (11)$$

The stator flux can be estimated by

$$\Psi_s^k = \frac{L_m}{L_r} \Psi_r^k + \left(1 - \frac{L_m^2}{L_s L_r}\right) \mathbf{i}_s^k. \quad (12)$$

Now, the stator flux prediction is obtained by the forward-Euler discretization:

$$\Psi_s^{k+1} = \Psi_s^k + T_s \mathbf{v}_s^k - T_s R_s \mathbf{i}_s^k. \quad (13)$$

The stator current prediction is also obtained by the forward-Euler discretization:

$$\mathbf{i}_s^{k+1} = C_1 \mathbf{i}_s^k + C_2 \Psi_s^k + \frac{T_s}{L_\sigma} \mathbf{v}_s^k \quad (14)$$

where $R_\sigma = (R_s + (L_m/L_r)^2 R_r)$ corresponds to the equivalent resistance, $C_1 = (1 - (R_\sigma T_s/L_\sigma))$, $L_\sigma = \sigma L_s$ is the leakage inductance of the machine, and $C_2 = (L_m/L_r) T_s/L_\sigma ((1/\tau_r) - j\omega^k)$.

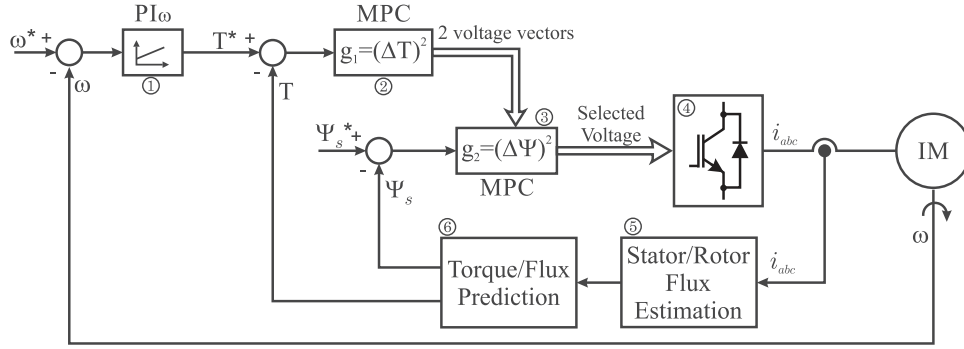

Fig. 3. Block diagram of SMPC of a 2L-VSI.

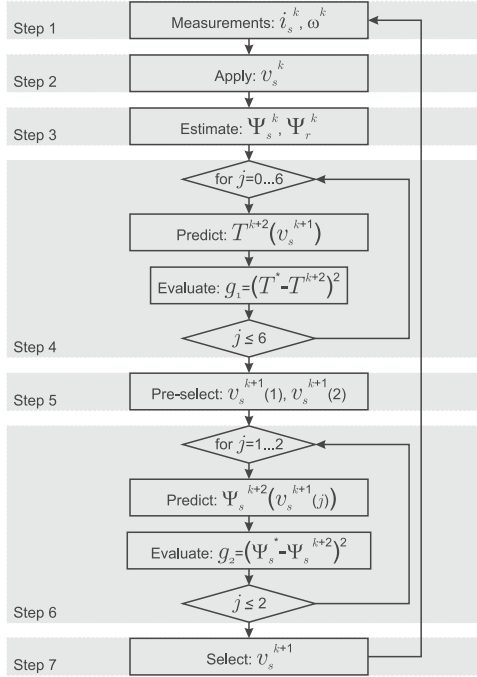

Fig. 4. Flow diagram of SMPC of a 2L-VSI.

Finally, the torque prediction depends on the stator flux and stator current predictions and can be written as follows:

$$T^{k+1} = \frac{3}{2}p|\Psi_s^{k+1} \otimes \mathbf{i}_s^{k+1}|. \quad (15)$$

IV. CONTROL STRATEGY

The proposed control strategy, called SMPC, uses a cascade structure to control more than one control objective. The strategy uses a sequence of cost functions to control each control objective. Instead of using a single cost function with several control objectives related by a weighting factor, the problem is solved by using different cost functions, each of which is dedicated to controlling a single control objective.

It should be noted that in the implementation of the predictive control strategy, the delay in the application of the optimal vector must be considered because the measurement, the data processing, and the optimization algorithm are not instantaneous. To

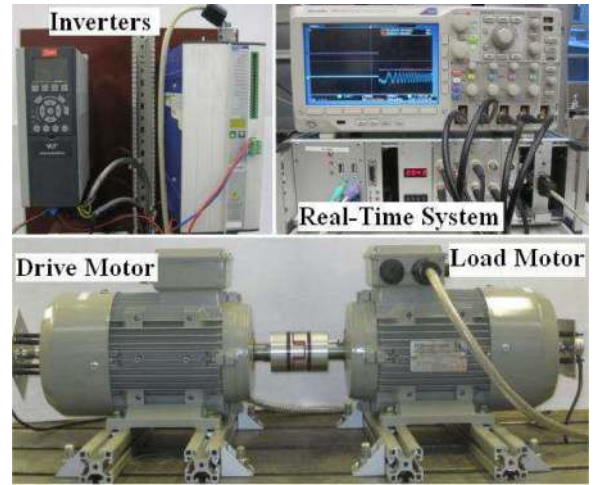

Fig. 5. Experimental test bench.

compensate for this delay, the control variables should be predicted for the future instant $k + 2$. This delay compensation strategy is well documented in [26].

The block diagram of the SMPC strategy is presented in Fig. 3. The error between the reference speed (ω^*) and the measured speed (ω) is introduced to a proportional-integral (PI) controller, which delivers the reference torque (T^*) to be generated by the machine.

The cost function for the torque control (g_1) is given by

$$g_1 = (T^* - T^{k+2})^2 \quad (16)$$

where T^{k+2} is the predicted torque, given by

$$T^{k+2} = \frac{3}{2}p|\Psi_s^{k+2} \otimes \mathbf{i}_s^{k+2}|. \quad (17)$$

This cost function is represented by block 2 of the block diagram in Fig. 3. In addition, g_1 is calculated for all seven different voltage vectors generated by the inverter.

The two voltage vectors that generate the smallest values for g_1 (that is, the smallest error) are selected for the next control step, which corresponds to the minimization of the flux error. This action is performed by the cost function g_2 , which corresponds to the flux error, defined by

$$g_2 = (\Psi_s^* - \Psi_s^{k+2})^2 \quad (18)$$

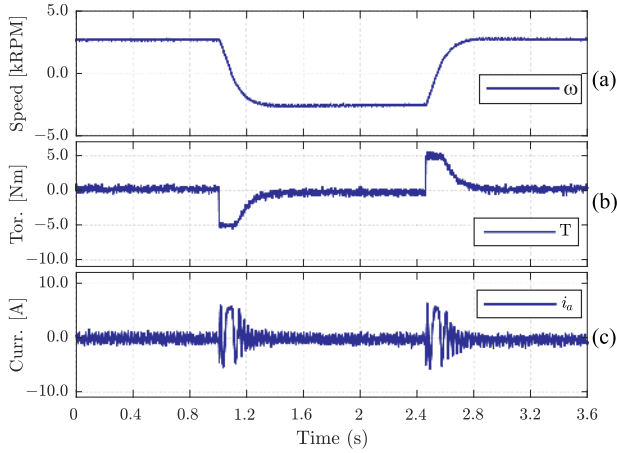

Fig. 6. Experimental results for speed reversal of ± 2772 r/min. (a) Rotor speed (ω). (b) Torque (T). (c) Stator current (i_a).

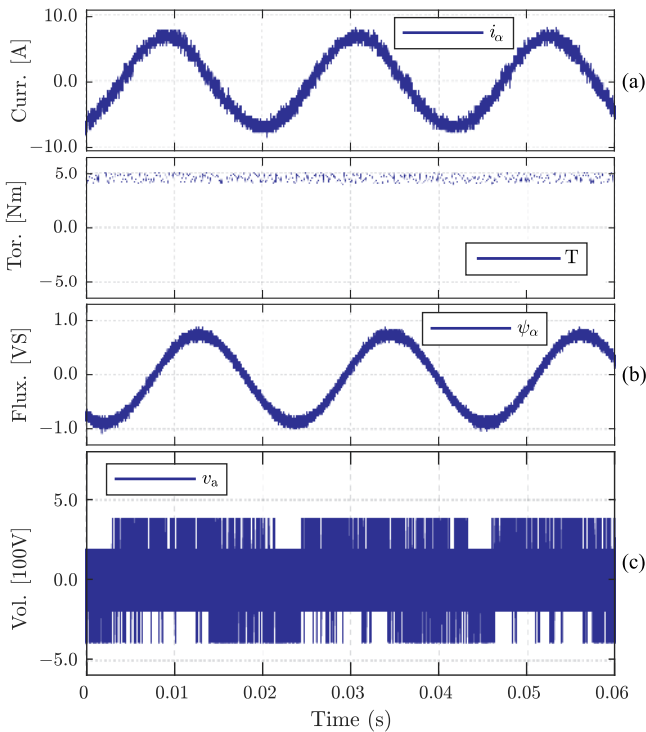

Fig. 7. Experimental results for steady state. (a) Stator current (i_a). (b) Torque (T). (c) Stator flux (ψ_α). (d) Stator voltage (v_a).

where Ψ_s^{k+2} is the predicted flux, given by

$$\Psi_s^{k+2} = \Psi_s^{k+1} + T_s \mathbf{v}_s^{k+1} - T_s R_s \mathbf{i}_s^{k+1}. \quad (19)$$

This cost function is evaluated for each of the two voltage vectors selected by the previous step of torque control. This operation is represented by block 3 in Fig. 3.

Finally, the voltage vector that minimizes g_2 is selected and delivered to the load.

In Fig. 3, block 4 represents the power circuit of the inverter, block 5 represents (11) and (12) for flux estimation and block 6 represents (19) and (17) for flux and torque prediction.

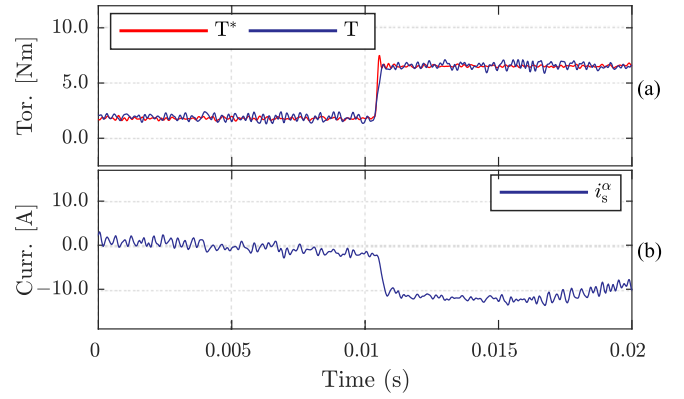

Fig. 8. Experimental results for torque control. (a) Torque and its reference (T^* , T). (b) Stator current (i_a).

Fig. 4 presents the flow diagram of the control strategy.

The strategy starts measuring stator current (i_s) and speed at sampling interval (k), what is observed in step 1 of Fig. 4.

In step 2, the voltage vector calculated in the previous sampling interval is applied.

Step 3 estimates stator flux and rotor flux at sampling interval k .

Step 4 calculates g_1 for all seven voltage vectors.

Step 5 selects the two vectors with the smallest value for g_1 .

Step 6 calculates g_2 for the two voltage vectors selected in the previous step.

Finally, step 7 selects the voltage vector that minimizes g_2 to be applied at the next sampling interval.

V. EXPERIMENTAL VALIDATION

A. Test Bench

The test bench consists of two 2.2-kW squirrel-cage induction motors, the load-side, and main motors. The load-side machine is driven by a Danfoss VLT FC-302 3.0-kW inverter. The main motor is driven by a modified SERVOSTAR620 14-kVA inverter that provides full control of the IGBT gates.

A selfmade 1.4 GHz real-time computer system is used. The rotor position is measured by a 1024-point-per-revolution incremental encoder. The sampling frequency is 16 kHz. The average switching frequency is around 3.3 kHz.

Table II shows the parameters of the test bench and Fig. 5 shows the equipment used in the laboratory.

B. Results

Fig. 6 shows the drive's dynamic response in a speed reversal of ± 2772 r/min. The variables recorded are speed (ω), torque (T), and stator current (i_a). During this operation, the amplitude of the stator flux is kept constant. It can be observed that the stator current has a fast increase in its amplitude, generating a fast change in the torque. The speed shows a smooth transition from 2772 to -2772 r/min.

Fig. 7 shows the steady-state behavior of the drive. The variables in this figure are stator current (i_a), torque (T), stator flux

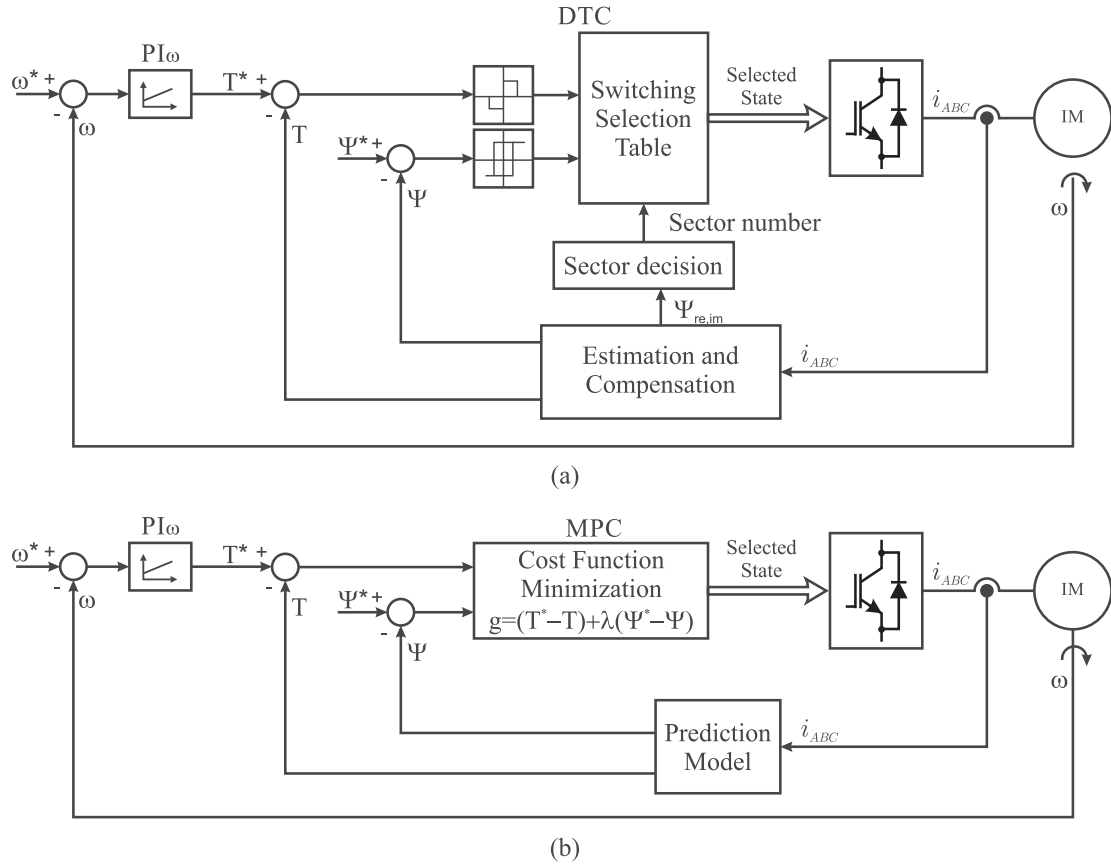

Fig. 9. Block diagram of (a) DTC and (b) standard MPC.

TABLE II
TEST BENCH PARAMETERS

Parameter	Value
DC-link voltage V_{DC}	582 V
R_s	2.68 Ω
R_r	2.13 Ω
L_m	275.1 mH
L_s	283.4 mH
L_r	283.4 mH
p	1
ω_{nom}	2772.0 r/min
T_{nom}	7.5 N·m
J	0.005 kg/m ²

(ψ_α), and stator voltage (v_α). All variables show the typical waveforms delivered by a two-level inverter.

As the flux is estimated based on the original measurement, i.e., the phase currents (a and b) in our test-bench, the measurements are not perfect in accuracy, errors will happen, which will introduce small bias at the end of this estimated flux. Some analysis has already been published in e.g. [27], and a potential solution can be that, using a full order estimator to get rid of this flux bias. A relevant report can be seen in [27] as well. But this is not our major goal in this paper; therefore, we could not deal with this in more detail.

Fig. 8 shows the transient behavior of the torque in greater detail. The variables included in this figure are reference torque (T^*), torque (T), and stator current (i_α). It can be observed that the torque reaches the reference in less than 1 ms. However, a PI controller could be adjusted so that the transient response is as fast as possible. The design procedure for this purpose is the magnitude optimum method [28], [29].

VI. CONCEPTUAL ASSESSMENT WITH DTC

The proposed strategy is different to DTC and standard model predictive control.

The main features of DTC are as follows:

- (1) Two hysteresis are used to control torque and flux.
- (2) The engineer/user must know the effect that each voltage vector will have on the behavior of torque and flux to decide which voltage will be delivered to the load.
- (3) The position of the stator flux in the complex plane must be identified by the control to select the right direction of the lookup table.

None of these important and necessary features are needed or considered using our proposed strategy, making it much simpler than DTC.

Fig. 9 shows the block diagram of DTC and the standard MPC. It is possible to see that DTC is different from MPC schemes (standard or proposed), and as the standard MPC uses only one cost function with a weighting factor, also it is possible to see the

difference between the standard MPC and the proposed control strategy.

VII. COMMENTS AND CONCLUSION

This paper has presented a new and very simple strategy for high-performance control of an IM called SMPC.

The method uses the approach of model predictive control and is based on the fundamental equations of the machine and of the inverter.

SMPC calculates the variables of the system in a sequential way using a single cost function for each control objective. Moreover, this work demonstrates that it is not necessary to use weighting factors to control torque and flux when using predictive control.

Experimental results confirm that the strategy effectively controls torque and flux. This simple strategy eliminates the problem of calculating any weighting factor.

MPC is conceptually different from established strategies for high-performance control of ac machines. It uses the capabilities of modern microprocessors and the discrete analysis of the system to be controlled (inverter and machine) in a simple way.

Finally, these results confirm that this strategy is a very attractive and promising alternative for high-performance ac drives.

REFERENCES

- [1] F. Blaschke, "The principle of field orientation as applied to the new transvector closed-loop system for rotating-field machines," *Siemens Rev.*, vol. 34, no. 3, pp. 217–220, 1972.
- [2] R. Gabriel, W. Leonhard, and C. J. Nordby, "Field-oriented control of a standard AC motor using microprocessors," *IEEE Trans. Ind. Appl.*, vol. IA-16, no. 2, pp. 186–192, Mar. 1980.
- [3] I. Takahashi and T. Noguchi, "A new quick-response and high-efficiency control strategy of an induction motor," *IEEE Trans. Ind. Appl.*, vol. IA-22, no. 5, pp. 820–827, Sep. 1986.
- [4] M. Depenbrock, "Direct self-control (DSC) of inverter-fed induction machine," *IEEE Trans. Power Electron.*, vol. 3, no. 4, pp. 420–429, Oct. 1988.
- [5] J. Rodríguez *et al.*, "Predictive current control of a voltage source inverter," *IEEE Trans. Ind. Electron.*, vol. 54, no. 1, pp. 495–503, Feb. 2007.
- [6] P. Cortes, M. P. Kazmierkowski, R. M. Kennel, D. E. Quevedo, and J. Rodríguez, "Predictive control in power electronics and drives," *IEEE Trans. Ind. Electron.*, vol. 55, no. 12, pp. 4312–4324, Dec. 2008.
- [7] S. Kouro, P. Cortes, R. Vargas, U. Ammann, and J. Rodríguez, "Model predictive control—Simple and powerful method to control power converters," *IEEE Trans. Ind. Electron.*, vol. 56, no. 6, pp. 1826–1838, Jun. 2009.
- [8] J. Rodríguez, R. M. Kennel, J. R. Espinoza, M. Trincado, C. A. Silva, and C. A. Rojas, "High-performance control strategies for electrical Drives: An experimental assessment," *IEEE Trans. Ind. Electron.*, vol. 59, no. 2, pp. 812–820, Feb. 2012.
- [9] H. Zhu, X. Xiao, and Y. Li, "Torque ripple reduction of the torque predictive control scheme for permanent-magnet synchronous motors," *IEEE Trans. Ind. Electron.*, vol. 59, no. 2, pp. 871–877, Feb. 2012.
- [10] J. Rodríguez *et al.*, "State of the art of finite control set model predictive control in power electronics," *IEEE Trans. Ind. Informat.*, vol. 9, no. 2, pp. 1003–1016, May 2013.
- [11] S. Vazquez *et al.*, "Model predictive control: A review of its applications in power electronics," *IEEE Ind. Electron. Mag.*, vol. 8, no. 1, pp. 16–31, Mar. 2014.
- [12] S. Kouro, M. A. Perez, J. Rodríguez, A. M. Llor, and H. A. Young, "Model predictive control: MPC's role in the evolution of power electronics," *IEEE Ind. Electron. Mag.*, vol. 9, no. 4, pp. 8–21, Dec. 2015.
- [13] Y. Zhang and H. Yang, "Two-vector-based model predictive torque control without weighting factors for induction motor drives," *IEEE Trans. Power Electron.*, vol. 31, no. 2, pp. 1381–1390, Feb. 2016.
- [14] S. Vazquez, J. Rodríguez, M. Rivera, L. G. Franquelo, and M. Norambuena, "Model predictive control for power converters and Drives: Advances and trends," *IEEE Trans. Ind. Electron.*, vol. 64, no. 2, pp. 935–947, Feb. 2017.
- [15] Z. Zhang, W. Tian, W. Xiong, and R. Kennel, "Predictive torque control of induction machines fed by 3L-NPC converters with online weighting factor adjustment using Fuzzy Logic," in *Proc. IEEE Transp. Electrific. Conf. Expo.*, Jun. 2017, pp. 84–89.
- [16] S. A. Davari, D. A. Khaburi, P. Stolze, and R. Kennel, "An improved finite control set-model predictive control (FCS-MPC) algorithm with imposed optimized weighting factor," in *Proc. 14th Eur. Conf. Power Electron. Appl.*, Aug. 2011, pp. 1–10.
- [17] M. Norambuena, S. Kouro, S. Dieckerhoff, and J. Rodríguez, "Finite control set-model predictive control of a stacked multicell converter with reduced computational cost," in *Proc. 41st Annu. Conf. IEEE Ind. Electron.*, 2015, pp. 1819–1824.
- [18] M. Norambuena, C. Garcia, and J. Rodríguez, "The challenges of predictive control to reach acceptance in the power electronics industry," in *Proc. 7th Power Electron. Drive Syst. Technol. Conf.*, Feb. 2016, pp. 636–640.
- [19] P. Cortes *et al.*, "Guidelines for weighting factors design in model predictive control of power converters and drives," in *Proc. IEEE Int. Conf. Ind. Technol.*, Feb. 10–13, 2009, pp. 1–7.
- [20] C. A. Rojas, J. Rodríguez, F. Villarroel, J. R. Espinoza, C. Silva, and M. Trincado, "Predictive torque and flux control without weighting factors," *IEEE Trans. Ind. Electron.*, vol. 60, no. 2, pp. 681–690, Feb. 2013.
- [21] V. P. Muddineni, S. R. Sandepudi, and A. K. Bonala, "Finite control set predictive torque control for induction motor drive with simplified weighting factor selection using TOPSIS method," *IET Electric Power Appl.*, vol. 11, no. 5, pp. 749–760, 2017.
- [22] A. Abbaszadeh, D. A. Khaburi, H. Mahmoudi, and J. Rodríguez, "Simplified model predictive control with variable weighting factor for current ripple reduction," *IET Power Electron.*, vol. 10, no. 10, pp. 1165–1174, 2017.
- [23] L. Guo, X. Zhang, S. Yang, Z. Xie, L. Wang, and R. Cao, "Simplified model predictive direct torque control method without weighting factors for permanent magnet synchronous generator-based wind power system," *IET Electric Power Appl.*, vol. 11, no. 5, pp. 793–804, 2017.
- [24] G. R. Slemon and A. Straughen, *Electric Machines*. Reading, MA, USA: Addison-Wesley, 1980.
- [25] A. E. Fitzgerald, C. Kingsley, S. D. Umans, and B. James, *Electric Machinery*, vol. 5, New York, NY, USA: McGraw-Hill, 2003.
- [26] P. Cortes, J. Rodríguez, C. Silva, and A. Flores, "Delay compensation in model predictive current control of a three-phase inverter," *IEEE Trans. Ind. Electron.*, vol. 59, no. 2, pp. 1323–1325, Feb. 2012.
- [27] S. A. Davari, D. A. Khaburi, F. Wang, and R. M. Kennel, "Using full order and reduced order observers for robust sensorless predictive torque control of induction motors," *IEEE Trans. Power Electron.*, vol. 27, no. 7, pp. 3424–3433, Jul. 2012.
- [28] K. J. Åström and T. Hägglund, *PID Controllers: Theory, Design, and Tuning*, vol. 2, Research Triangle Park, NC, USA: Instrum. Soc. Am., 1995.
- [29] J. W. Umland and M. Safiuddin, "Magnitude and symmetric optimum criterion for the design of linear control systems: what is it and how does it compare with the others?" *IEEE Trans. Ind. Appl.*, vol. 26, no. 3, pp. 489–497, May 1990.



Margarita Norambuena (S'12–M'14) received the B.S. and M.S. degrees in electric engineering from the Universidad Tecnica Federico Santa Maria (UTFSM), Valparaiso, Chile, in 2013, and the Ph.D. degree (summa cum laude) in electronics engineering from the UTFSM in 2017.

She received a scholarship from Chilean National Research, Science and Technology Committee in 2014 to pursue the Ph.D. degree studies in power electronics with UTFSM and Technische Universitaet Berlin. She also received a scholarship from German

Academic Exchange Service in 2015 to pursue the Ph.D. degree studies with TUB. She is currently an Assistant Professor with Universidad Andres Bello, Santiago, Chile. Her research interests include multilevel converters, model predictive control of power converters and drives, energy storage systems, renewable energy, and microgrids systems.



Jose Rodriguez (M'81–SM'94–F'10) received the Engineering degree in electrical engineering from the Universidad Tecnica Federico Santa Maria, Valparaiso, Chile, in 1977 and the Dr.-Ing. degree in electrical engineering from the University of Erlangen, Erlangen, Germany, in 1985.

He has been with the Department of Electronics Engineering, Universidad Tecnica Federico Santa Maria, since 1977, where he was a full Professor and President. Since 2015, he has been the President of Universidad Andres Bello, Santiago, Chile. He has coauthored two books, several book chapters, and more than 400 journal and conference papers. His main research interests include multilevel inverters, new converter topologies, control of power converters, and adjustable-speed drives.

Dr. Rodriguez has received a number of best paper awards from journals of the IEEE. He is a member of the Chilean Academy of Engineering. In 2014, he received the National Award of Applied Sciences and Technology from the Government of Chile. In 2015, he received the Eugene Mittelmann Award from the Industrial Electronics Society of the IEEE.



Cristian Garcia (M'15) received the M.Sc. and Ph.D. degrees in electronics engineering from the Universidad Tecnica Federico Santa Maria, Valparaiso, Chile, in 2013 and 2017, respectively.

He is currently an Assistant Professor with Universidad Andres Bello, Santiago, Chile. His research interests include electric transportation applications, variable-speed drives, matrix converters, and model predictive control of power converters and drives.



Zhenbin Zhang (S'13–M'16) was born in Shandong, China. He received the B.S. degree in electrical engineering and automation from Harbin Engineering University, Harbin, China, in 2008, and the Ph.D. degree (*summa cum laude*) in control theory and engineering from the Institute for Electrical Drive Systems and Power Electronics, Technical University of Munich, Munich, Germany, in 2016.

From 2008 to 2011, he studied control theory and engineering with Shandong University, Jinan, China.

From 2016 to 2017, he was a Research Fellow and the

Team Leader for the “Modern Control Strategies for Electrical Drives” Group with the Institute for Electrical Drive Systems and Power Electronics, Technical University of Munich. Since 2017, he has been a Full Professor with Shandong University, Shandong, China. His research interests include power electronics and electrical drives, sustainable energy systems, and smart grids.

Dr. Zhang was a recipient of the VDE Award, Germany, in 2017.



Ralph M. Kennel was born in 1955 in Kaiserslautern, Germany. He received the Diploma and the Dr.-Ing. (Ph.D.) degrees in electrical engineering from the University of Kaiserslautern, Kaiserslautern, Germany, in 1979 and 1984, respectively.

From 1983 to 1999, he worked on several positions with Robert BOSCH GmbH, Stuttgart, Germany. Until 1997, he was responsible for the development of servo drives. He was one of the main supporters of VECON and SERCOS interface, two multicompany development projects for a microcontroller, and a digital interface especially dedicated to servo drives. Furthermore, he actively took part in the definition and release of new standards with respect to CE marking for servo drives. Between 1997 and 1999, he was responsible for “Advanced and Product Development of Fractional Horsepower Motors” in automotive applications. His main activity was preparing the introduction of brushless drive concepts to the automotive market. From 1994 to 1999, he was a Visiting Professor with the University of Newcastle-upon-Tyne, Newcastle-upon-Tyne, U.K. From 1999 to 2008, he was a Professor of electrical machines and drives with Wuppertal University, Wuppertal, Germany. Since 2008, he has been a Professor for electrical drive systems and power electronics with Technische Universitaet Muenchen, Munich, Germany. His main interests include sensorless control of ac drives, predictive control of power electronics, and hardware-in-the-loop systems.

Dr. Kennel is a Fellow of IET (former IEE) and a Chartered Engineer in the U.K. Within IEEE, he is a Treasurer of the Germany Section as well as the Distinguished Lecturer of the Power Electronics Society. He has received the Harry Owen Distinguished Service Award from IEEE-PELS in 2013 as well as the EPE Association Distinguished Service Award in 2015. He was appointed “Extraordinary Professor” by the University of Stellenbosch, Stellenbosch, South Africa, from 2016 to 2019 and “Visiting Professor” with the Haixi Institute by the Chinese Academy of Sciences from 2016 to 2021. There he was appointed as “Jiaxi Lu Overseas Guest Professor” in 2017.

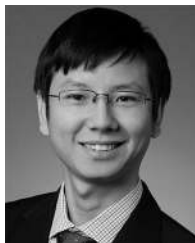

Fengxiang Wang (S'13–M'14) was born in Jiujiang, China, in 1982. He received the B.S. degree in electronic engineering and the M.S. degree in automation from Nanchang Hangkong University, Nanchang, China, in 2005 and 2008, respectively. In 2014, he received the Ph.D. degree from the Institute for Electrical Drive Systems and Power Electronics, Technische Universitaet Muenchen, Munich, Germany.

He is currently working as a full Professor and Deputy Director of Quanzhou Institute of Equipment Manufacturing, Haixi Institutes, Chinese Academy

of Sciences, China. His research interests include predictive control and sensorless control for electrical drives.