

A WDM Optical Backplane with AWG Based Passive Routing

E.D. Kyriakis-Bitaros^{2,1}, E. Grivas¹, G. Halkias¹, S. Katsafouros¹, P. Dumon³,
G. Morthier³, R. Baets³, T. Farrell⁴, N. Ryan⁴, I. McKenzie⁵, and E. Armadillo⁵

1:NCSR Demokritos, Institute of Microelectronics, Agia Paraskevi, Attiki, Greece.

2:TEI of Piraeus, Dept. of Electronics, Egaleo, Greece, Email: mpitz@teipir.gr

3:University of Ghent, INTEC, Ghent, Belgium.

4:Intune Technologies, Dublin, Ireland.

5:ESA/ESTEC, Noordwijk, The Netherlands

Abstract: An optical backplane based on Wavelength Division Multiplexing (WDM) is introduced. It is a tunable transmitter fixed receiver (TT-FR) architecture, which incorporates an NxN Arrayed Waveguide Grating (AWG) element for passive data routing. A four-node prototype has been built using high-speed FPGAs for the implementation of the control plane. Bit-Error-Rate (BER) versus power incident on the receiver using three different AWGs has been measured at a data rate of 10Gbps per link under static and dynamically changing configurations.

Keywords: Optical backplane, Arrayed Waveguide Grating (AWG), Wavelength Division Multiplexing (WDM)

1. Introduction

The need for high bandwidth in interconnection networks due to the increased processing power and latency requirements has led to the investigation of the potential of optical interconnects at the backplane level of high-end computing systems [1,2]. Since the requirement for on-board satellite data and signal handling is expected to increase dramatically in the near future, the potential use of such systems in space applications should be also investigated. Wavelength Division Multiplexing (WDM) is a widely applied technique in long haul telecommunications and Metropolitan Area Networks (MANs) [3], which offers increased bandwidth through a single optical fiber. However, the advantages of WDM are not extensively investigated for chip-to-chip and board-to-board interconnects. In [4] a WDM based optical backplane for high-speed IP routers is proposed using passive routing of data packets through the network. A prototype system working at a data-rate of 40Gbps is presented using a PC-based controller to guarantee collision free operation. The application of networking concepts to optoelectronic multiprocessor architecture design offer advantages to the system designer since already tested solutions to the problems occurring in the development of complex hybrid architectures and associated protocols may be transferred from one domain to the other [7].

In this paper we introduce a WDM optical backplane architecture and we describe the design of a four-node demonstrator using tunable transmitters, fixed receivers and high-speed FPGAs implementing the data and control plane of the system. Bit-Error-Rate (BER) measurements versus power incident to the receiver for static backplane operation and under dynamic reconfiguration are reported for three different Arrayed Waveguide Gratings (AWGs) [5] employed, which exhibit different characteristics in terms

of size, sensitivity to temperature and polarization and performance.

2. Backplane Architecture and Implementation

2.1 Architecture

The general WDM backplane architecture is shown in Fig. 1. The system depicted in Fig. 1a possesses N nodes connected to an NxN AWG routing element [5]. By using different wavelengths any node can exchange data with any other node. This architecture is a Tunable Transmitter Fixed Receiver (TT-FR) configuration meaning that every node can be tuned to send data to any of the permissible wavelengths, while the receiver accepts incoming data in all wavelengths. Multicast features can also be implemented by using an MxM AWG with M>N and adding extra star couplers as shown in Fig. 1b (some AWG inputs remain unused in this case).

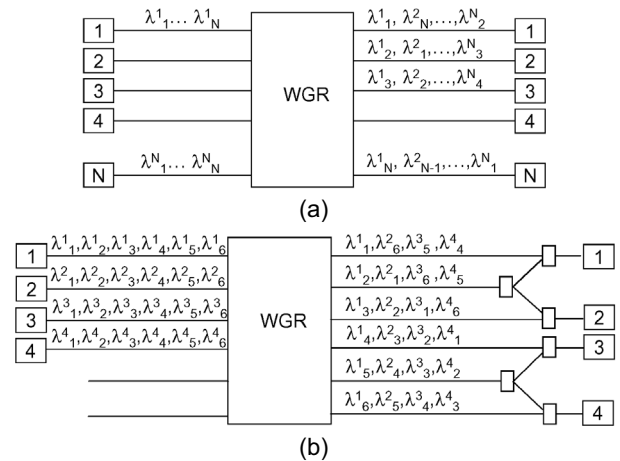

Figure 1. Basic backplane architecture with NxN AWG, (a) number of nodes equals to AWG I/Os and (b) use of larger AWG permits multicasting.

The passive wavelength router transparently implements the network connectivity on the physical level together with the laser circuitry. By using this combination of tunable transmitters, fixed receivers and fixed communication paths in the router, responsibility for adding more flexibility in the network is put on higher network levels. Although the AWG by itself is a non-blocking routing element, collisions may arise on the overall backplane when two or more nodes are transmitting simultaneously to a single node. Thus, an arbitration mechanism should be used for the collision free operation of the backplane.

2.2 Implementation

A four-node prototype system has been built based on the previously described architecture. In order to reduce prototype implementation cost and enable fast switching experiments, two of the nodes have sending and receiving capability using COTS transponders, while the other two nodes possess burst-mode receivers only. All nodes operate at a full data rate of 10Gb/s, therefore the network has a two way capacity of 20Gb/s or an aggregate routing capacity of 60Gb/s.

Wavelength router: Three different AWGs have been used and tested, namely a commercially available 4x4 AWG in silica-on-silicon (SOS), a research prototype 4x4 AWG in silicon-on-insulator (SOI) [6], and a prototype 8x8 AWG in polymer technology. The later has been combined with three star couplers in order to demonstrate broadcasting capabilities of the system. The characteristics of the three AWGs used are summarized in Table I.

AWG Type	No. of I/Os	Size (mm ²)	Insertion Loss (dB)	Cross-talk (dB)	Temp. depend.	Polar. depend.
SOS	4x4	3000	7-9	-25 dB	Low	Low
SOI	4x4	2	12-14	-12 dB	High	High
Polymer	8x8	1000	< 12	< -20	Low	High

Table I. Basic characteristics of the AWGs.

Transponders: The modules used employ a laser-less transponder driven by an external fast wavelength tunable laser source. The transponders are capable of sending and receiving 10Gbps optical data streams and communicate electrically through the standard 300-pin MSA interface with the data and control module described in the following. The tuneable lasers have 80 50GHz-spaced channels from 1528nm to 1563 nm (C band). During switching, the output of the laser is blanked to avoid disruption of other communication channels. For all possible wavelength transitions the maximum switching time is <200ns and the wavelength is specified to be within ± 2.5 GHz of the expected value. As the demonstrator uses a small subset of the wavelengths the typical switching time is <100ns.

The receivers are based on PIN photodiodes. Two of them are part of the transponders and incorporate an optical amplifier for dynamic range extension, while the other two are burst-mode receivers (in-house developed by Intune Technologies).

Control Unit: The data and control plane of the backplane has been implemented using the Stratix-II® high speed FPGAs of Altera. Concerning the data plane every node generates outgoing data packets (comprising of a variable length receiver lock-up pattern, a fixed start-of-data pattern and a $2^{23}-1$ pseudorandom bit sequence), processes incoming data, sets up communication links and performs Bit Error Rate (BER) measurements. The internal data-path is implemented using a 64-bit architecture operating at a core frequency of 155.52 MHz in order to produce the required serial data rate of 9.953 Gbps.

The control of data flow within the backplane is implemented as a hybrid form of centralized/distributed control, where all nodes contain predefined routing tables and communication schemes and a master node is responsible for controlling synchronization between the

nodes. The wavelength address on the tunable laser module is selected through a proprietary Fast Wavelength Assignment Interface. The control boards are connected through a JTAG interface to a PC for programming the FPGAs and for data retrieval.

3. Test Results

Initially, the error free operation of every node has been verified using electrical and optical loopback connections. No errors have been recorded for more than 10 hours of continuous operation leading to a BER $< 10^{-15}$.

Subsequently, evaluation of the overall system performance and comparison of the three routing elements was performed. External attenuation of the optical signal was used in order to obtain BER vs received power curves. The first set of measurements aimed to get the single channel BER figure by setting-up a single point-to-point connection through the routing element. The optical power budget needed to achieve a low BER of 10^{-11} varies for the three AWGs. Specifically, it is -31.7 dBm for the SOS, -31 dBm for the SOI and -30.1 dBm for the polymer component. Moreover, the SOS component presents the smaller variation between different channels (<0.2 dB), while the polymer and the SOI AWGs are more sensitive to wavelength change (0.7 dB and 1.2 dB, respectively). The greater variation observed in the SOI AWG is partially due to the fact that the tunable laser output and the AWG input wavelength are not exactly matched in all cases. Unicast and broadcast BER measurements performed using the polymer AWG showed a 0.5 dB power variation between all four channels for broadcast operation, which is mainly due to insertion loss variations of the external couplers used to implement the broadcasting scheme.

The next set of experiments intended to determine the influence of incoherent and coherent cross-talk and the power penalty introduced by single and multiple channel cross-talk. Initially, power penalty due to single source cross-talk was measured. The cross-talk level (CL) was being adjusted, when necessary, by attenuating the optical power of the appropriate transmitter. The power penalty for incoherent cross-talk was found to be 0.05 dB for the SoS AWG at a CL of 25 dB and 0.2 dB for the Polymer device at a CL of 22.5 dB. For the SOI AWG, the power penalty varied from 0.1 dB at a CL of 19 dB to 1dB at a CL of 11.1 dB. The power penalty due to coherent cross-talk presented greater variations, as expected. For the SoS device, it was in the range of 0.05 – 0.075 dB (for different optical paths) at a CL of 25 dB and increased to 0.2 – 0.3 dB as the CL decreased to 13.4 dB with attenuation of the optical signal, as shown in Fig. 2. The SOI AWG gave a 2dB power penalty at a CL of 14.1 dB that reduced to 0.2 dB as the CL increased to 20.1 dB by attenuating the signal causing the cross-talk. The polymer device experienced the greater sensitivity to coherent cross-talk as the power penalty was 1.25 dB at a CL of 22.5 dB and further increased to 3 dB at a CL of 20 dB. All power penalties were measured at a BER of 10^{-10} . Finally, an external modulated tunable source was used with the SOS AWG as a third transmitting node, since as mentioned earlier only two transponders were available. As it is shown in Fig. 2, the cumulative power penalty due to the two cross-talk sources increased to 0.45 dB at a CL of 13.4 dB, which implies the effect is additive.

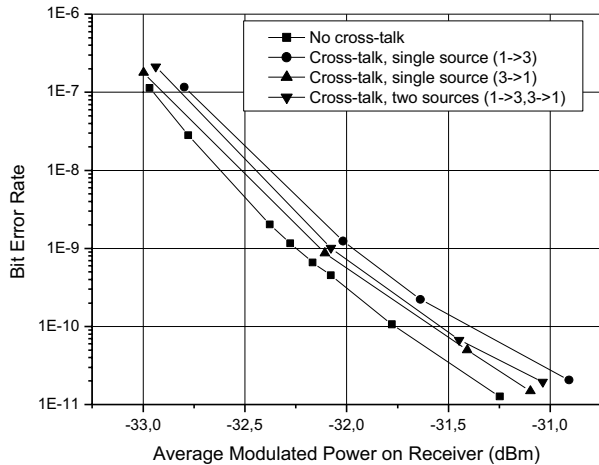

Figure 2. BER measurements under the presence of coherent cross-talk (CL=13.4db, AWG: SOS)

The tests reported up to now are static since the backplane configuration does not change during the test. A set of dynamic tests has been also performed using the burst-mode receivers of nodes 2 and 3. Two scenarios have been examined: always on and off-to-on switching. In the always-on case nodes 0 and 1 send data to nodes 2 and 3, respectively, for a specific time interval and after that a switching occurs, so that node 0 sends to 3 and 1 to 2. In the on-to-off case the receiver under test gets data from a transmitting node (i.e. node 0), thereupon gets no data for some time and finally receives data from another node (i.e. node 1). This represents the worst case, since the receiver locks on the incoming data after a period of darkness. In both cases, constant crosstalk is always present as both transmitters are always on. In Fig 3 the BER measurements for a fast switching using a preamble length of 500 ns and a packet length of 4 s along with the respective static curves are shown. No degradation of the backplane operation is observed, thus, fast switching in the range of 600 ns (laser switching time <100 ns) can be achieved.

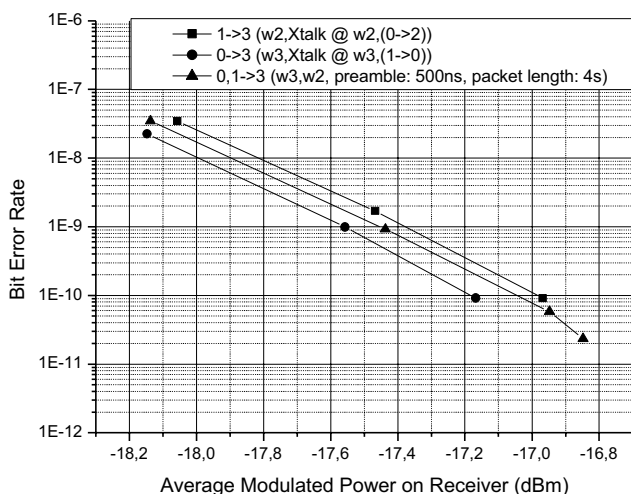

Figure 3. BER measurements under Burst Mode Switching Operation.

4. Conclusions

A four-node wavelength routed multigigabit optical backplane, based on a passive AWG router and tunable transponders, has been demonstrated. Three types of routers have been successfully tested: in silica-on-silicon (SoS), in silicon-on-insulator (SOI) and in polymer. The control plane of the backplane is implemented as a hybrid form of centralised/distributed control with a master node responsible for triggering events and controlling synchronisation and it has been realized using high-speed FPGAs. BER measurements vs optical power, for static and dynamic backplane configuration using 10Gpbs data streams, reveal the scalability of the architecture to large number of ports with switching times less than 600 ns.

5. Acknowledgement

This work was supported by ESA/ESTEC under Contract No. 17884/03/NL/HE, Multigigabit Optical Backplane Interconnections. P. Dumon thanks the Institute for the Promotion of Innovation through Science and Technology in Flanders (IWT-Vlaanderen) for a specialization grant.

6. References

- [1] Rolston D.R., Plant D.V., Szymanski T.H., Hinton H.S., Hsiao W.S., Ayliffe M.H., Kabal D., Venditti M.B., Desai P., Krishnamoorthy A.V., Goossen K.W., Walker J.A., Tseng B., Hui S.P., Cunningham J.E., Jan W.Y., A hybrid-SEED smart pixel array for a four-stage intelligent optical backplane demonstrator, *IEEE J. STQE*, Vol. 2, No. 1, Apr. 1996, pp. 97 – 105.
- [2] Yoon K.B., Cho I.-K., Ahn S. H., Jeong M.Y., Lee, D.J., Heo Y.U., Rho, B.S., Park, H.-H. and Rhee, B.-H., Optical Backplane System Using Waveguide-Embedded PCBs and Optical Slots, *IEEE J. Lightwave Technol.*, Vol. 22, No. 9, Sept. 2004, pp. 2119-2127.
- [3] Maier M., *Metropolitan Area WDM networks, An AWG Based Approach*, Kluwer Academic Pub., 2004.
- [4] Gripp J., Duell M., Simsarian J.E., Bhardwaj A., Bernasconi P., Laznicka O. and Zingibl M. Optical Switch Fabrics for Ultra-High-Capacity IP Routers, *IEEE J. Lightwave Technol.*, Vol. 21, No. 11, Nov. 2003, pp. 2839-2850.
- [5] Bernasconi P., Doerr C., Dragone C., Cappuzzo M. Laskowski E. and Paunescu A. Large N x N waveguide grating routers, *IEEE J. Lightwave Technol.*, vol. 18, No. 7, July 2000, pp. 985–991.
- [6] Dumon P., Bogaerts W., Van Thourhout D., Morthier G., Baets R., Jaenen P., Beckx S., Wouters J., Farrell T., Ryan N., Grivas E., Kyriakis-Bitzaros E., Halkias G. and McKenzie I., A Nanophotonic 4x4 Wavelength Router in Silicon-on-Insulator, *2006 OFC/NFOEC Meeting*, Anaheim, California.
- [7] J. Rorie, P.J. Marchand, J. Ekman, F.E. Kiamilev, S.C. Esener, "Application of Networking Concepts to Optoelectronic Multiprocessor Architectures", *IEEE JSTQE*, Vol. 5, No. 2, Mar./Apr. 1999.