

A WIDEBAND E-SHAPED MICROSTRIP PATCH ANTENNA FOR 5–6 GHz WIRELESS COMMUNICATIONS

B.-K. Ang and B.-K. Chung

Faculty of Engineering
Multimedia University
63100 Cyberjaya, Malaysia

Abstract—A wideband E-shaped microstrip patch antenna has been designed for high-speed wireless local area networks (IEEE 802.11a standard) and other wireless communication systems covering the 5.15–5.825 GHz frequency band. Two parallel slots are incorporated to perturb the surface current path, introducing local inductive effect that is responsible for the excitation of the second resonant mode. The length of the center arm can be trimmed to tune the frequency of the second resonant mode without affecting the fundamental resonant mode. A comprehensive parametric study has been carried out to understand the effects of various dimensional parameters and to optimize the performance of the antenna. A substrate of low dielectric constant is selected to obtain a compact radiating structure that meets the demanding bandwidth specification. The reflection coefficient at the input of the optimized E-shaped microstrip patch antenna is below -10 dB over the entire frequency band. The measurement results are in excellent agreement with the HFSS simulation results.

1. INTRODUCTION

Wireless local area networks (WLAN) are widely used worldwide. The IEEE 802.11b and 802.11g standards utilize the 2.4-GHz ISM band. The frequency band is license-free, hence the WLAN equipment will suffer interference from microwave ovens, cordless phone, Bluetooth devices and other appliances that use this same band. The 802.11a standard uses the 5-GHz band which is cleaner to support high-speed WLAN. However, the segment of frequency band used varies from one region of the world to another. In the U.S., the 802.11a system may use the 5.15–5.35 GHz band and 5.725–5.825 GHz band. Some

countries allow the operation in the 5.47–5.825 GHz band. A traveler with 802.11a transceiver that can cover the frequency range from 5.15 GHz to 5.825 GHz will be able to gain access to a local WLAN network in different parts of the world. Microstrip antenna is the ideal choice for such an application due to its low-profile, lightweight, low-cost and ease of integration with microwave circuits. However, standard rectangular microstrip patch antenna has the drawback of narrow bandwidth. Enhancement of the performance to cover the demanding bandwidth is necessary.

The bandwidth of microstrip antenna may be increased using air substrate [1]. However, dielectric substrate must be used if compact antenna size is required [2]. A few approaches can be applied to improve the microstrip antenna bandwidth. These include increasing the substrate thickness, introducing parasitic element either in coplanar or stack configuration, and modifying the shape of a common radiator patch by incorporating slots. The last approach is particularly attractive because it can provide excellent bandwidth improvement and maintain a single-layer radiating structure to preserve the antenna's thin profile characteristic. The successful examples include E-shaped patch antennas [3–7], U-slot patch antennas [8], and V-slot patch antennas [9].

For the E-shaped patch antenna, two parallel slots are incorporated to introduce a second resonant mode, resulting in a dual-band antenna. If the feed point is located at the tip of the center arm as in [3–6], the second resonant mode will be introduced at a lower frequency than the fundamental resonant mode. If the feed point is moved to the base of the center arm [7], the second resonant mode will be introduced at a higher frequency than the fundamental resonant mode.

In this paper, a wideband E-shaped microstrip antenna for wireless communications is designed to cover the 5.15–5.825 GHz frequency band. A comprehensive parametric study has been carried out to understand the effects of various dimensional parameters and to optimize the performance of the final design. The theoretical simulations are performed using HFSS software. Experimental results are obtained for several E-shaped antennas to compare the measurement with the simulation results.

2. ANTENNA DESIGN METHOD

The antenna geometry is shown in Fig. 1. First, a rectangular microstrip patch antenna is designed based on the standard design procedure to determine the length (L) and width (W) for resonant

frequency at 5.25 GHz. It is fed by a coaxial probe at position (x_o, y_o) . Two parallel slots are incorporated to perturb the surface current path, introducing local inductive effect that is responsible for the excitation of a second resonant mode. The slot length (L_s), slot width (W_s), and the center arm dimensions (W_t and L_t) of the E-shaped patch control the frequency of the second resonant mode and the achievable bandwidth. By introducing a second resonant mode at around 5.8 GHz, the coupling of the two resonant modes may form a wide bandwidth response covering the 5.15–5.825 GHz band.

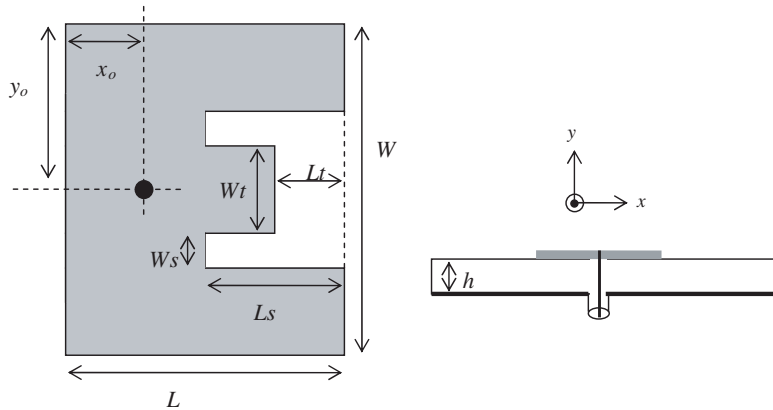

Figure 1. Configuration of the E-shaped microstrip antenna.

A common rectangular patch antenna can be represented by means of the equivalent circuit of Fig. 2(a). The resonant frequency is determined by L_1C_1 . At the resonant frequency, the impedance of the series LC circuit is zero, and the antenna input impedance is given by resistance R . By varying the feed location, the value of resistance R may be controlled such that it matches the characteristic impedance of the coaxial feed. When a pair of slots is incorporated, the equivalent circuit can be modified into the form as shown in Fig. 2(b). The second resonant frequency is determined by L_2C_2 . Analysis of the circuit network shows that the antenna input impedance is given by

$$Z_{in} = R + j \frac{(\omega L_1 - 1/\omega C_1)(\omega L_2 - 1/\omega C_2)}{\omega(L_1 + L_2) - (1/\omega C_1 + 1/\omega C_2)}$$

The imaginary part of the input impedance is zero at the two series-resonant frequencies determined by L_1C_1 and L_2C_2 , respectively. Of course, this is by no mean the exact model of the E-shaped antenna because the equation shows that there is a parallel-resonant mode

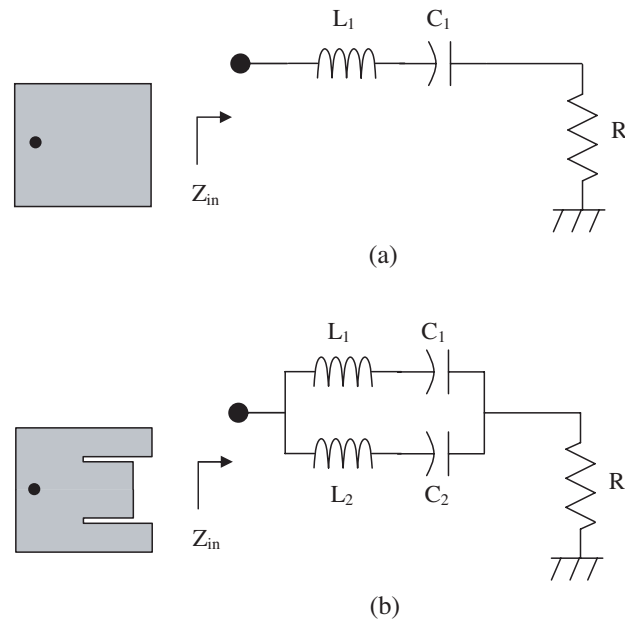

Figure 2. Equivalent circuits of (a) rectangular patch and (b) E-shaped microstrip antennas.

between the two series-resonant frequencies. Nevertheless, it serves to explain the operating principle of the antenna design. If the two series-resonant frequencies are too far apart, the reactance of the antenna at the midband frequency may be too high and the reflection coefficient at the antenna input may be unsatisfactory. If the two series-resonant frequencies are set too near to each other, the parallel-resonant mode may affect the overall frequency response and the reflection coefficient near each of the series-resonant frequencies may be degraded. The question now is: how would the slot length, slot width, slot position and the length of center arm affect the values of L_2 and C_2 ? The results of a parametric study are reported in the next section.

3. PARAMETRIC STUDY

A substrate with dielectric permittivity of 2.2 and thickness of 3.2 mm is selected to obtain a compact radiation structure that at the same time meets the demanding bandwidth specification. It is fed by a 50- Ω SMA connector (with inner conductor and outer conductor diameters of 1.3 mm and 4.7 mm, respectively). The inner conductor is soldered

on the top surface of the patch antenna while the outer conductor body is soldered to the ground plane. Simulations are performed using HFSS software. The four parameters L_s , W_s , L_t and W_t are set as variable and their effects on the impedance bandwidth are studied.

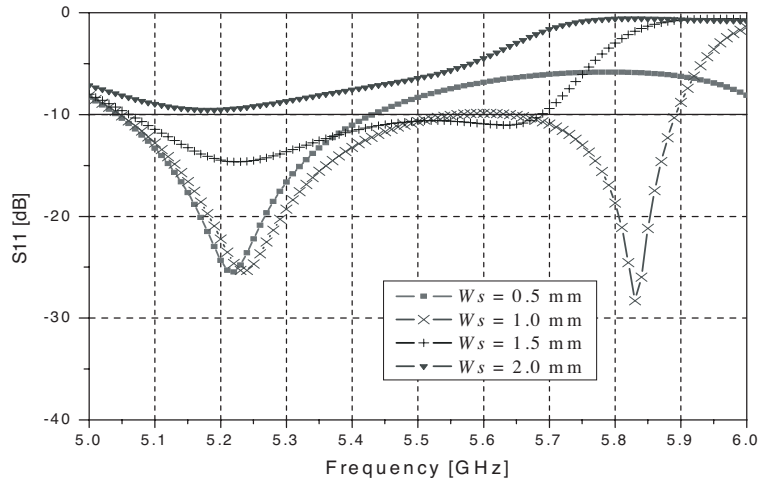

Figure 3. Simulated reflection coefficients for various W_s .

Figure 3 shows the reflection coefficient of a few E-shaped patch antenna examples. The antenna parameters are listed below (in millimeters):

$$(L, W, h) = (17.2, 20.0, 3.2), \quad (x_0, y_0) = (5.2, 10.0)$$

$$L_s = 10, \quad L_t = 2.8, \quad W_t = 6.2$$

The slot width W_s is varied from 0.5 mm to 2.0 mm. The parallel slots introduce local inductive effect by forcing the surface current to flow around the slots. The wider is the slot, the higher is the inductance L_2 . Hence, the resonant frequency of the second resonant mode decreases with wider slot. The resonant frequency of the fundamental resonant mode is barely affected. With a slot width of 0.5 mm, the frequency of the second resonant mode is too high and it gives rise to a dual-band antenna rather than a wideband antenna. With a slot width of 2.0 mm, the second resonant mode is too close to the fundamental resonant mode and it affects the overall frequency response.

With $L_t = 2.8$ mm, $W_t = 6.2$ mm, and $W_s = 1.0$ mm, the slot length L_s is varied from 9 mm to 11 mm. Increasing the slot length will increase the inductance L_2 because the diversion of surface current around the slots will be more intensive. Hence, the frequency of the

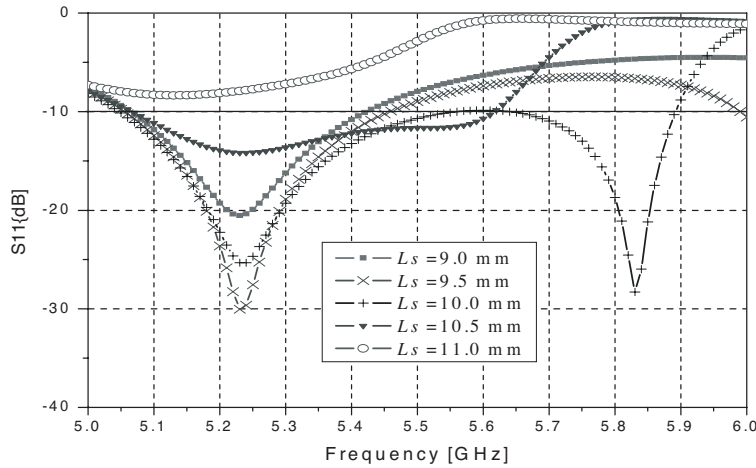

Figure 4. Simulated reflection coefficients for various L_s .

second resonant mode decreases, as shown in Fig. 4. For slot length less than 9 mm, there is little diversion of the surface current and the second resonant mode cannot be excited. For slot length longer than 9 mm, a small change in L_s will cause a big change in the second resonant mode.

The center arm of the E-shaped patch antenna acts like a tuning capacitor. Widening the center arm will increase capacitance C_2 . As shown in Fig. 5, the resonant frequency of the second resonant mode decreases when Wt is increased from 4.2 mm to 8.2 mm (with $L_s = 10$ mm, $Ws = 1.0$ mm, $Lt = 2.8$ mm).

The length of the center arm can be reduced by trimming an offset Lt from the radiating edge. As Lt is increased from 1.8 mm to 3.8 mm (with $L_s = 10$ mm, $Ws = 1.0$ mm, $Wt = 6.2$ mm), the frequency of the second resonant mode is increased as shown in Fig. 6. The antenna only exhibits the fundamental resonant mode when Lt is less than 1.8 mm. One can trim Lt to tune the frequency of the second resonant mode and thus the bandwidth. The second resonant mode may be tuned to a frequency higher than 6 GHz, but the S11 between the two resonant frequencies will be poorer than -10 dB and unable to meet the desired bandwidth specification.

4. MEASURED RESULTS

A rectangular patch and a few E-shaped microstrip antennas are fabricated. Measurement results are obtained to compare with

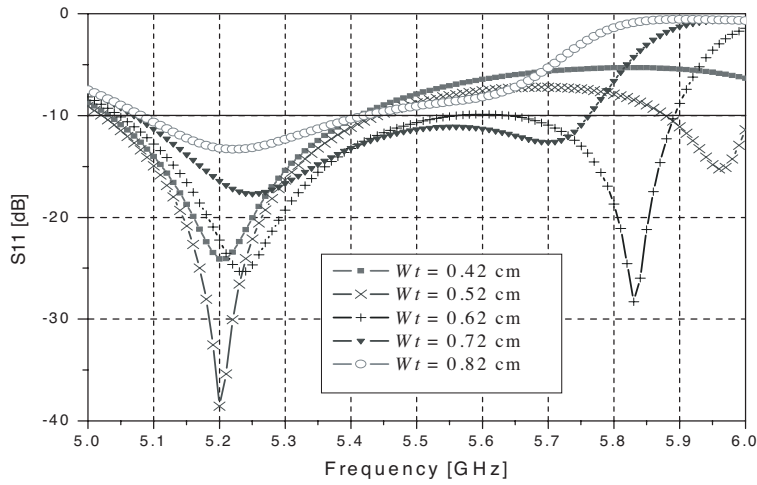

Figure 5. Simulated reflection coefficients for various Wt .

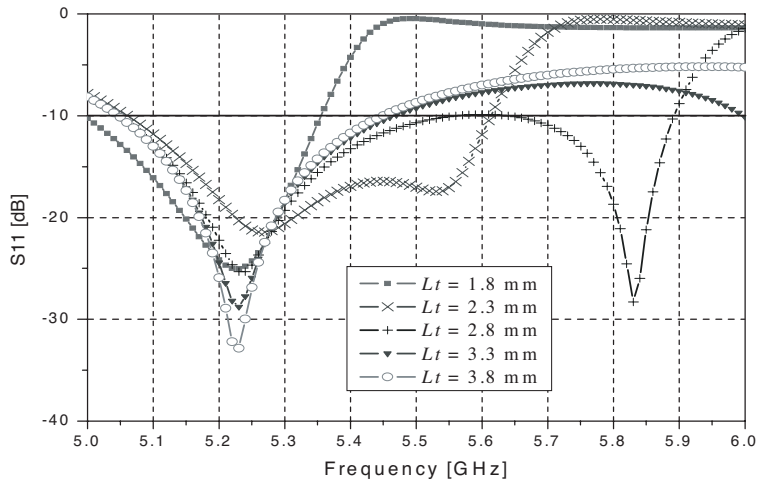

Figure 6. Simulated reflection coefficients for various Lt .

simulation results. In order to maintain a concise style of presentation, only one design example is reported in this paper. For a rectangular patch antenna, with dielectric constant of 2.2 and substrate thickness of 3.2 mm, the typical bandwidth is about 400 MHz (or 8% fractional bandwidth) at 5.25 GHz. Fig. 7 shows the measurement and simulation results for an E-shaped microstrip antenna with $L_s = 10$ mm, $W_s =$

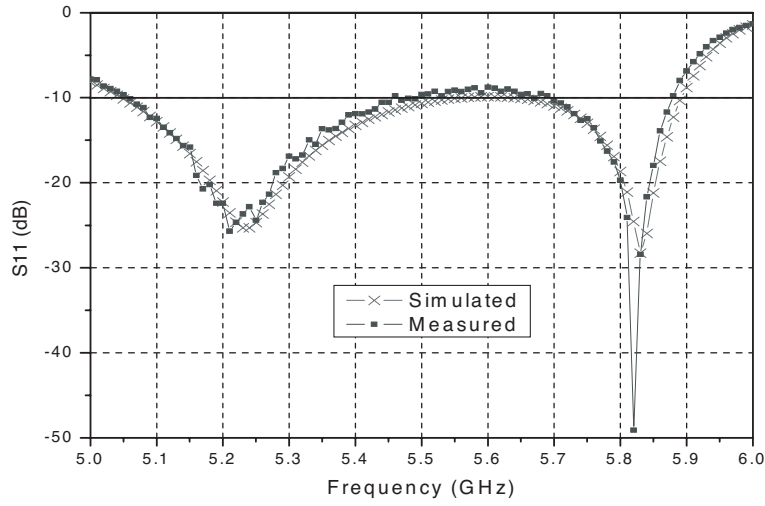

Figure 7. Simulated and measured reflection coefficients of an E-shaped microstrip antenna.

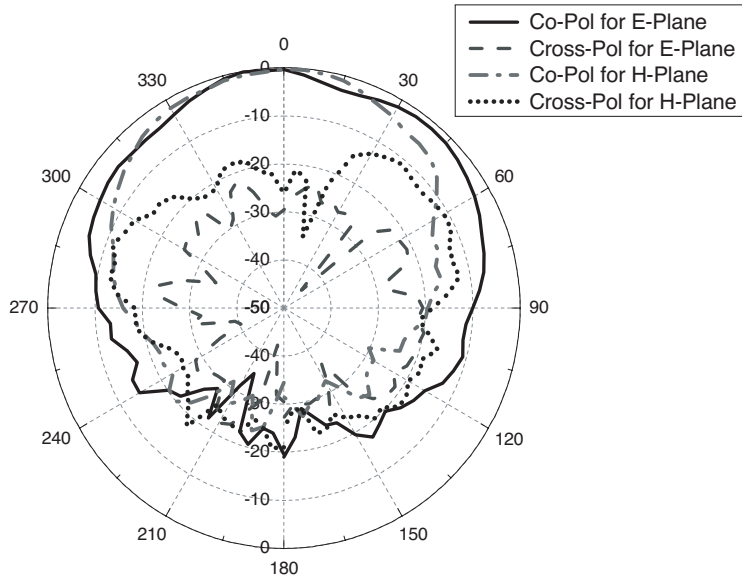

Figure 8. Measured radiation pattern of E-shaped microstrip antenna at 5.25 GHz.

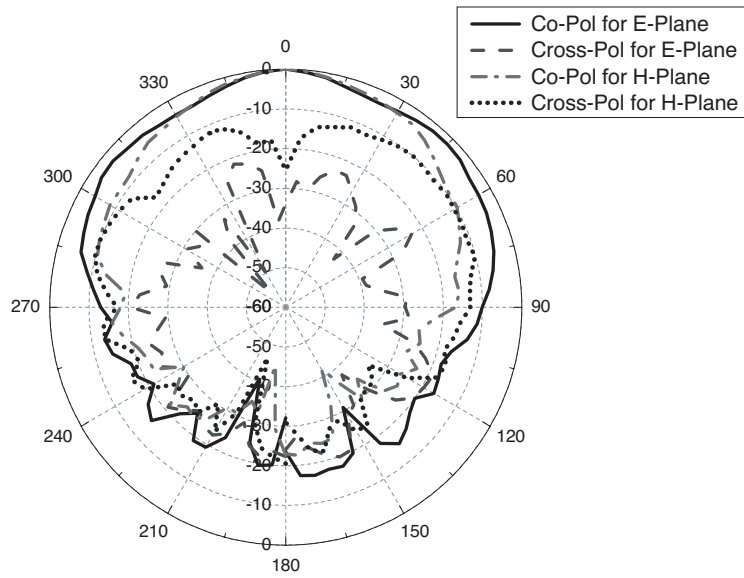

Figure 9. Measured radiation pattern of E-shaped microstrip antenna at 5.80 GHz.

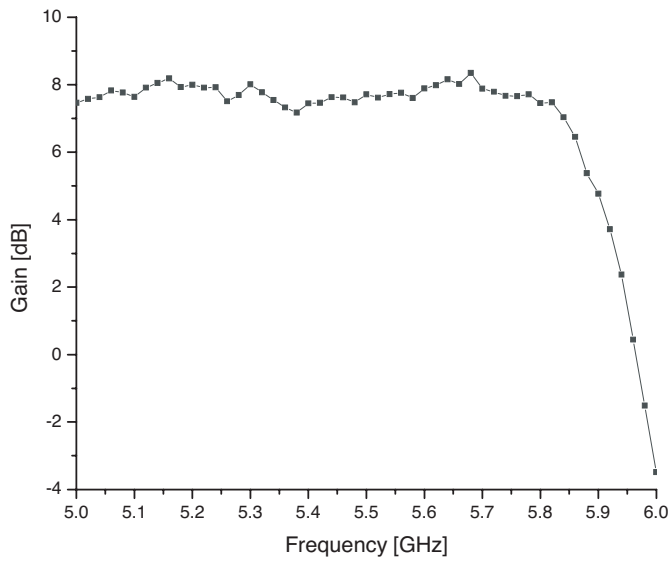

Figure 10. Measured radiation pattern gain of E-shaped antenna.

1.0 mm, $Wt = 6.2$ mm and $Lt = 2.8$ mm. The design gives the widest bandwidth with reflection coefficient below -10 dB. A bandwidth of 830 MHz (or 15.2% fractional bandwidth), covering 5.05 GHz to 5.88 GHz, is achieved. The experimental results are in excellent agreement with the simulation results.

The radiation patterns of the antenna are measured in an anechoic chamber. Fig. 8 and Fig. 9 show the results at 5.25 GHz and 5.80 GHz, respectively. Both the E-plane and H-plane have broadside directional radiation patterns similar to a common rectangular patch antenna. The radiation characteristic exhibits little variation at other frequencies over the 830-MHz bandwidth. Fig. 10 shows the measured antenna gain is about 7.5 dBi over the entire frequency range from 5.15 GHz to 5.825 GHz, with ripple of less than ± 0.6 dB.

5. CONCLUSION

A wideband E-shaped microstrip patch antenna has been designed for high-speed wireless communication systems. The reflection coefficient is below -10 dB from 5.05 GHz to 5.88 GHz. The performance is more than meeting the demanding bandwidth specification to cover the 5.15–5.825 GHz frequency band. At the same time, the antenna is thin and compact with the use of low dielectric constant substrate material. These features are very useful for worldwide portability of wireless communication equipment. The parametric study provides a good insight on the effects of various dimensional parameters. It provides guidance on the design and optimization of E-shaped microstrip patch antenna. By locating the feed point at the base rather than the tip of the center arm, the resonant frequency of the second resonant mode can be tuned without affecting the resonant frequency of the fundamental resonant mode. The bandwidth can be easily tuned by trimming the length of the center arm. Excellent agreement between the measurement and simulation results is obtained.

REFERENCES

1. Ayoub, A. F. A., "Analysis of rectangular microstrip antennas with air substrates," *Journal of Electromagnetic Waves and Applications*, Vol. 17, No. 12, 1755–1766, 2003.
2. Vetharatnam, G., B. K. Chung, and H. T. Chuah, "Design of a microstrip patch antenna array for airborne SAR applications," *Journal of Electromagnetic Waves and Applications*, Vol. 19, No. 12, 1687–1701, 2005.

3. Yang, F., X. X. Zhang, X. Ye, and Y. Rahmat-Samii, "Wide-band E-shaped patch antennas for wireless communications," *IEEE Trans. Antennas Propagat.*, Vol. 49, No. 7, 1094–1100, July 2001.
4. Wong, K. L. and W. H. Hsu, "A broad-band rectangular patch antenna with a pair of wide slits," *IEEE Trans. Antennas Propagat.*, Vol. 49, No. 9, 1345–1347, September 2001.
5. Ge, Y., K. P. Esselle, and T. S. Bird, "E-shaped patch antennas for high-speed wireless networks," *IEEE Trans. Antennas Propagat.*, Vol. 52, No. 12, 3213–3219, Dec. 2004.
6. Ge, Y., K. P. Esselle, and T. S. Bird, "A compact E-shaped patch antenna with corrugated wings," *IEEE Trans. Antennas Propagat.*, Vol. 54, No. 8, 2411–2413, Aug. 2006.
7. Yu, A. and X. X. Zhang, "A method to enhance the bandwidth of microstrip antennas using a modified E-shaped patch," *Proceedings of Radio and Wireless Conference*, 261–264, Aug. 10–13, 2003.
8. Lee, K. F., et al., "Experimental and simulation studies of the coaxially fed U-slots rectangular patch antenna," *IEE Proc. Microw. Antenna Propag.*, Vol. 144, No. 5, 354–358, October 1997.
9. Rafi, G. and L. Shafai, "Broadband microstrip patch antenna with V-slot," *IEE Proc. Microw. Antenna Propag.*, Vol. 151, No. 5, 435–440, October 2004.
10. Sim, C. Y. D., J. S. Row, and Y. Y. Liou, "Experimental studies of a shorted triangular microstrip antenna embedded with dual V-shaped slots," *Journal of Electromagnetic Waves and Applications*, Vol. 21, No. 1, 15–24, 2007.