

# A2Z Control System- DTMF Control System

Er. Zatin Gupta<sup>1</sup>, Payal Jain<sup>2</sup>, Monika<sup>3</sup>

GJCST Classification (FOR)  
H.4.3

**Abstract-Dual Tone Multi Frequency (DTMF) technique for controlling the domestic and industrial appliances is being presented in this paper. A simple mobile phone which works on DTMF tone, used to control the domestic as well as industrial electrical appliances which with the control system which we have designed here for experimental study. In recent state of affairs, domestic, military and industrial applications use this technique because it can be operated from remote location. Radio frequency (RF) is also used for wireless communication but DTMF is an alternate for RF. Mobile phone is used to send the DTMF code from remote location to the control system. The blocks of system are mobile phone, Microcontroller (AT89S52), DTMF Decoder (MT8870D), Relays and power supply. This paper shows the working areas where the system is applicable and how it has advantages over RF.**

## I. INTRODUCTION

The main features of DTMF Decoder (MT8870D) are as follows:

- DTMF Receiver
- Low power consumption
- Power-down mode
- Inhibit mode

Main applications are as follows:

- Receiver system
- Remote control
- Telephone answering machine

### 1) BLOCK DIAGRAM

The block diagram of system consists of the following equipments:

#### a) Mobile Phone

Wireless control of domestic and industrial appliances is the objective of this paper so to achieve the objective, a mobile is used here. Particular button of mobile keypad produces specific DTMF tone that will transmit by the operator of mobile to the control system.

#### b) Dtmf Decoder (Mt8870d)

The MT8870D is DTMF receiver consisting of digital decoder. It uses digital counting techniques for detecting and decoding all 16 DTMF tone pairs into a 4 bit- code. The micro controller takes the 4 bit code as input.

About<sup>1</sup>. Lecturer, Department of Information and Technology, Maharishi Markandeshwar Engineering College, Maharishi Markandeshwar University, Mullana, Ambala (Haryana) zatin.gupta2000@gmail.com, Mobile No: +919050406988

About<sup>2</sup>. Lecturer, Department of Information and Technology, Maharishi Markandeshwar Engineering College, Maharishi Markandeshwar University, Mullana, Ambala (Haryana) payaljain2006@gmail.com, Mobile No: +919466742552.

About<sup>3</sup>. Lecturer, Department of Information and Technology, Maharishi Markandeshwar Engineering College, Maharishi Markandeshwar University, Mullana, Ambala (Haryana) monawadhwa@gmail.com

### c) Microcontroller (At89s52)

Microcontroller is the control unit of this system. We have used AT89S52. It is low power, high performance CMOS 8-Bit controller with 4K bytes of ROM and 128 bytes of RAM.

### d) Dtmf Signal

DTMF is most widely known method of Multi Frequency Shift Keying (MSFK) data transmission technique. DTMF was developed by Bell Labs to be used in the telephone system. Most telephones today uses DTMF dialing (or "tone" dialing).

	1209 Hz	1336 Hz	1477 Hz	1633 Hz
697 Hz	1	2	3	A
770 Hz	4	5	6	B
852 Hz	7	8	9	C
941 Hz	*	0	#	D

Table 1: DTMF signal frequency encoding table.

The DTMF technique outputs distinct representation of 16 common alphanumeric characters (0-9, A-D, \*, #) on the keypad. The lowest frequency used is 697Hz and the highest frequency used is 1633Hz, as shown in Table 1.

### e) Relay Logic

To ON/OFF the appliances we need relays because relay is an on/off switch that can control by microprocessor automatically. Appliances are connected to these relays. Relays are of two types SPDT, DPDT, here SPDT Relays used.

### 2) EXPERIMENTAL STUDY

The main controlling technique using DTMF can be explained as follow: Integrated DTMF Receiver

#### a) Features

It has low power consumption, adjustable guard time, inhibit mode. These are the features, which we have used here to achieve the goal of this paper.

#### b) Applications

It is widely used in Mobiles, Remote control, Personal computers, Telephone answering Machine, etc.

## II. EXPLANATION OF MT8870D

The MT8870D is a complete DTMF receiver integrating both the band splitFilter and digital decoder functions. The filter section uses switched capacitor techniques for high and low group filters; the decoder uses digital counting techniques to

detect and decode all 16 DTMF tone pairs into a 4-bit BCD code.

### 1) PRACTICAL DESCRIPTION

The MT8870D monolithic DTMF receiver has small size, low power consumption and high performance. Its architecture consists of a band split filter section, which separates the high and low frequency tones, followed by a digital counting section which verifies the frequency and duration of the received tones before passing the corresponding code to the output bus to the Micro Controller.

#### a) Filter Section

Separation of the low and high group tones is achieved by applying the DTMF signal to the inputs of band pass filters, the bandwidths of which correspond to the low and high group frequencies.

#### b) Decoder Section

Decoder Section having the digital counting techniques to determine the frequencies of the incoming tones and to verify that they correspondingly generate a standard DTMF frequency.

#### c) Steering Circuit

Before registration of a decoded tone pair, the receiver checks for a valid signal duration. This check is performed by an external RC time constant.

#### d) Power-Down Feature

+ 5V voltage applied to pin no 6 (PWDN) to power down the device which minimize the power consumption in a standby mode. It stops the oscillator and the functions of the filters.

#### e) Inhibit Mode

Inhibit mode is enabled by applying +VE voltage to the pin 5 (INH). It inhibits the detection of tones representing characters A, B, C, and D. The output code will remain the same as previously received.

### 2) ULN 2003A

The ULN2003A is a high voltage; high current Darlington pair arrays each containing seven open collector Darlington pairs with common emitters. Each channel rated at 500mA and can withstand peak currents of 600mA. Suppression diodes are included for inductive load driving and the inputs are pinned opposite the outputs to simplify board layout and it is used to operate relays.

The main features of ULN 2003A are as Follows:

- Seven Darlington pair Per Package
- Output Current 500mA per Driver
- Output Voltage 50V
- Integrated Suppression Diodes for Inductive loads.
- Outputs can be paralleled for higher current.

### III. EXPERIMENTAL STUDY

The experimental study of DTMF communication is to be carried out in three stages. The FIRST STAGE is testing the output of mobile phone or DTMF Encoder (91241B). The SECOND STAGE is decoding of transmitted data. The THIRD STAGE is to perform the operation which is supposed to be done by pressing the particular key of mobile phone keypad.

#### 1) First Stage

The goal of this stage is to verify that the DTMF signal produced and transferred to the control system is appropriate and not affected by noise. The control System with DTMF receiver is programmed to perform a series of operations. The DTMF characters can be heard as "beeps". We make such an arrangement of taking the DTMF tone and then checks its frequency with the standard and then matches both the results if they are same then it means that are signal is not distorted and hence supplied to the control system.

#### 2) Second Stage

This stage is carried out to decode the DTMF signal and to produce the output which is sent to the Micro-Controller. The decoding is done by the DTMF Decoder (MT8870D) and it gives the output in BCD format i.e. The FOUR digit code which is sent to the Micro-Controller. In this control system we are presenting that code also on LED's so that we can easily decode the signal and one LED is used to tell that a DTMF signal is received and decoded i.e. whenever a DTMF signal is received and decoded by decoder then a signal LED will blink. By this means we decode the DTMF Signal.

#### 3) Third Stage

This stage is to perform the operation which is supposed to be done by the decoding the DTMF signal into a particular BCD code that represents a decimal digit basically. To do this, an experiment is performed using distinct values and repeated it many times to test the onboard DTMF receiver. The commands, as illustrated in Table are directly represented by the DTMF characters. Since the main focus is to check that whether the operations defined in coding of the system are working properly, as they actually supposed to be or not. If there is any problem then it means that an error occurs there in between so again the process started from SECOND STAGE until we got the appropriate result.

X	0	1	2	3	4	5
Y	Off All	On First	On Second	Off First	Off Second	On All

Table shows the operations performed

X tells DTMF signal produced by such key & Y tells Operation performed. To check the working of system, we gave values in between 0-5 to the system and test the functionality of the control system.

IV. A2Z CONTROL SYSTEM

Block Diagram

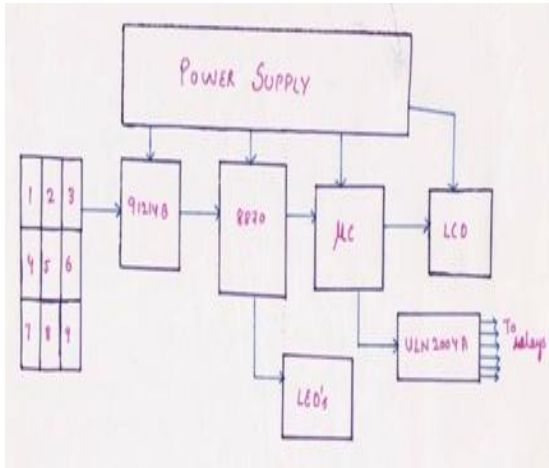

Working Image



Our control system has two relays to operate two devices such as to charge mobile phone and to blow the bulb.

Keypad Assignment

Keyboard Assignment

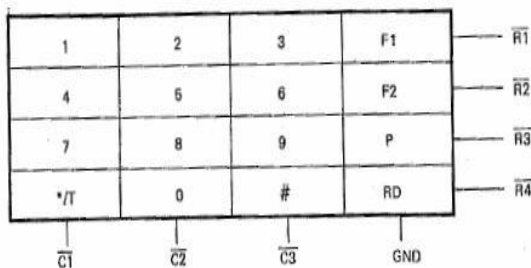

Decoder Circuit

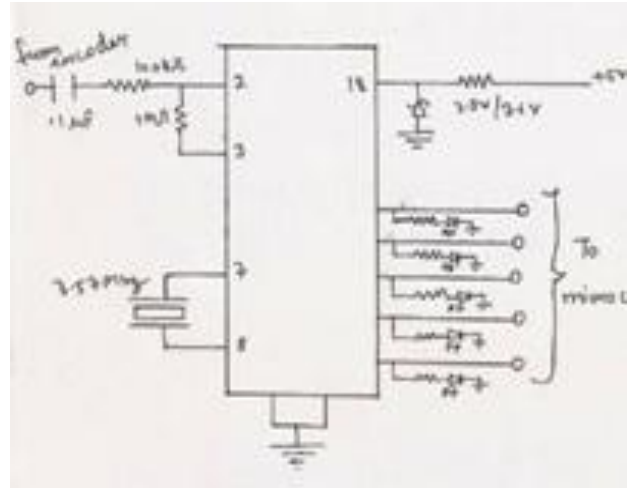

V. CONCLUSION

This paper has described the design and specifications of the DTMF based control system and it is feasible to make such a control system also it has many advantages over any other media i.e. RF because RF can be easily received by any other antenna but DTMF tone cannot be. As we are making a call from a mobile to the mobile which is connected to the system then only that particular mobile will receive the signal and decode it. This approach is very secure and is very useful in domestic as well as industrial usage. Although DTMF has advantages like low cost, simplicity, very popular in telephone industry so we conclude that this kind of control systems are very useful in today's scenario.

VI. REFERENCES

To complete this paper successfully we need to refer with many websites and papers, some of them are as mentioned below:

- 1) A. Shatnawi, A. Abu-El-Haija, A. Elabdalla, "A Digital Receiver for Dual-Tone Multi-frequency (DTMF) Signals", Technology Conference, Ottawa, CA, May 1997.
- 2) M. Felder, J. Mason, B. Evans, "Efficient Dual-Tone Multi-frequency Detection Using Non-uniform Discrete Fourier Transform", IEEE Signal Processing Letters, Vol. 5, No. 7, July 1998.
- 3) A. Plaisant, "Long Range Acoustic Communications", OCEANS '98 Conference Proceedings, Vol. 1, pp. 472, Sept. 1998.
- 4) Z. Wei-Qing, W. Chang-Hong, P. Feng, Z. Min, W. Rui, Z. Xiang-Jun, D. Yong-Mei, "Underwater Acoustic Communication System of AUV", OCEANS '98 Conference Proceedings, Vol. 1, pp. 477, Sept. 1998.
- 5) M. J. Callahan Jr., "Integrated DTMF Receiver", IEEE J. Solid States Circuits, vol. SC-14, pp. 85-90, Feb. 1979.
- 6) www.alldatasheet.com

- 7) [www.active-robots.com/.../av-modules.shtml](http://www.active-robots.com/.../av-modules.shtml) -  
United Kingdom
- 8) Robots, Androids, and Animations 12 Incredible Projects You Can Build” by John Iovine Second Edition McGraw-Hill.
- 9) PDA Robotics Using Your Personal Digital Assistant to Control Your Robot” by Douglas H. Williams McGraw-Hill
- 10) Remote robot control system based on DTMF of mobile phone” published in 6th IEEE International Conference.