

## **AAPM and GEC-ESTRO guidelines for image-guided robotic brachytherapy: Report of Task Group 192**

Tarun K. Podder, Luc Beaulieu, Barrett Caldwell, Robert A. Cormack, Jostin B. Crass, Adam P. Dicker, Aaron Fenster, Gabor Fichtinger, Michael A. Meltsner, Marinus A. Moerland, Ravinder Nath, Mark J. Rivard, Tim Salcudean, Danny Y. Song, Bruce R. Thomadsen, and Yan Yu

Citation: *Medical Physics* **41**, 101501 (2014); doi: 10.1118/1.4895013

View online: <http://dx.doi.org/10.1118/1.4895013>

View Table of Contents: <http://scitation.aip.org/content/aapm/journal/medphys/41/10?ver=pdfcov>

Published by the [American Association of Physicists in Medicine](#)

---

### **Articles you may be interested in**

[Dosimetric characterization and output verification for conical brachytherapy surface applicators. Part II. High dose rate  \$^{192}\text{Ir}\$  sources](#)

*Med. Phys.* **41**, 022104 (2014); 10.1118/1.4862506

[Report of AAPM TG 135: Quality assurance for robotic radiosurgery](#)

*Med. Phys.* **38**, 2914 (2011); 10.1118/1.3579139

[A dosimetric uncertainty analysis for photon-emitting brachytherapy sources: Report of AAPM Task Group No. 138 and GEC-ESTRO](#)

*Med. Phys.* **38**, 782 (2011); 10.1118/1.3533720

[Reliability of EUCLIDIAN: An autonomous robotic system for image-guided prostate brachytherapy](#)

*Med. Phys.* **38**, 96 (2011); 10.1118/1.3523097

[AAPM Task Group 128: Quality assurance tests for prostate brachytherapy ultrasound systems](#)

*Med. Phys.* **35**, 5471 (2008); 10.1118/1.3006337

---

**SMARTER, FASTER QA**  
**RECLAIM YOUR NIGHTS AND WEEKENDS!**

**One minute IMRT and VMAT QA!**  
**no arrays, chambers, film or EPID necessary**

 **MobiusFX**

 **MOBIUS**  
MEDICAL SYSTEMS  
INNOVATIVE SOFTWARE FOR MODERN RADIATION ONCOLOGY  
[www.mobiusmed.com](http://www.mobiusmed.com)

# AAPM and GEC-ESTRO guidelines for image-guided robotic brachytherapy: Report of Task Group 192

Tarun K. Podder<sup>a)</sup>

*Department of Radiation Oncology, University Hospitals, Case Western Reserve University, Cleveland, Ohio 44122*

Luc Beaulieu

*Department of Radiation Oncology, Centre Hospitalier Univ de Quebec, Quebec G1R 2J6, Canada*

Barrett Caldwell

*Schools of Industrial Engineering and Aeronautics and Astronautics, Purdue University, West Lafayette, Indiana 47907*

Robert A. Cormack

*Department of Radiation Oncology, Harvard Medical School, Boston, Massachusetts 02115*

Jostin B. Crass

*Department of Radiation Oncology, Vanderbilt University, Nashville, Tennessee 37232*

Adam P. Dicker

*Department of Radiation Oncology, Thomas Jefferson University, Philadelphia, Pennsylvania 19107*

Aaron Fenster

*Department of Imaging Research, Robarts Research Institute, London, Ontario N6A 5K8, Canada*

Gabor Fichtinger

*School of Computer Science, Queen's University, Kingston, Ontario K7L 3N6, Canada*

Michael A. Meltsner

*Philips Radiation Oncology Systems, Fitchburg, Wisconsin 53711*

Marinus A. Moerland

*Department of Radiotherapy, University Medical Center Utrecht, Utrecht, 3508 GA, The Netherlands*

Ravinder Nath

*Department of Therapeutic Radiology, Yale University School of Medicine, New Haven, Connecticut 06520*

Mark J. Rivard

*Department of Radiation Oncology, Tufts University School of Medicine, Boston, Massachusetts 02111*

Tim Salcudean

*Department of Electrical and Computer Engineering, University of British Columbia, Vancouver, British Columbia V6T 1Z4, Canada*

Danny Y. Song

*Department of Radiation Oncology, Johns Hopkins University School of Medicine, Baltimore, Maryland 21231*

Bruce R. Thomadsen

*Department of Medical Physics, University of Wisconsin, Madison, Wisconsin 53705*

Yan Yu

*Department of Radiation Oncology, Thomas Jefferson University, Philadelphia, Pennsylvania 19107*

(Received 7 November 2013; revised 8 August 2014; accepted for publication 24 August 2014; published 30 September 2014)

In the last decade, there have been significant developments into integration of robots and automation tools with brachytherapy delivery systems. These systems aim to improve the current paradigm by executing higher precision and accuracy in seed placement, improving calculation of optimal seed locations, minimizing surgical trauma, and reducing radiation exposure to medical staff. Most of the applications of this technology have been in the implantation of seeds in patients with early-stage prostate cancer. Nevertheless, the techniques apply to any clinical site where interstitial brachytherapy is appropriate. In consideration of the rapid developments in this area, the American Association of Physicists in Medicine (AAPM) commissioned Task Group 192 to review the state-of-the-art in the field of robotic interstitial brachytherapy. This is a joint Task Group with the Groupe Européen de Curiothérapie-European Society for Radiotherapy & Oncology (GEC-ESTRO). All developed and reported robotic brachytherapy systems were reviewed. Commissioning and quality assurance procedures for the safe and consistent use of these systems are also provided. Manual seed placement

techniques with a rigid template have an estimated *in vivo* accuracy of 3–6 mm. In addition to the placement accuracy, factors such as tissue deformation, needle deviation, and edema may result in a delivered dose distribution that differs from the preimplant or intraoperative plan. However, real-time needle tracking and seed identification for dynamic updating of dosimetry may improve the quality of seed implantation. The AAPM and GEC-ESTRO recommend that robotic systems should demonstrate a spatial accuracy of seed placement  $\leq 1.0$  mm in a phantom. This recommendation is based on the current performance of existing robotic brachytherapy systems and propagation of uncertainties. During clinical commissioning, tests should be conducted to ensure that this level of accuracy is achieved. These tests should mimic the real operating procedure as closely as possible. Additional recommendations on robotic brachytherapy systems include display of the operational state; capability of manual override; documented policies for independent check and data verification; intuitive interface displaying the implantation plan and visualization of needle positions and seed locations relative to the target anatomy; needle insertion in a sequential order; robot–clinician and robot–patient interactions robustness, reliability, and safety while delivering the correct dose at the correct site for the correct patient; avoidance of excessive force on radioactive sources; delivery confirmation of the required number or position of seeds; incorporation of a collision avoidance system; system cleaning, decontamination, and sterilization procedures. These recommendations are applicable to end users and manufacturers of robotic brachytherapy systems. © 2014 American Association of Physicists in Medicine. [<http://dx.doi.org/10.1118/1.4895013>]

Key words: brachytherapy, implantation, robots, automation, treatment planning

## TABLE OF CONTENTS

1	INTRODUCTION . . . . .	3	3.B.12	CHUG robot—An ultrasound image-guided prostate brachytherapy system . . . . .	15
2	CLASSIFICATIONS OF ROBOTS . . . . .	3	3.B.13	MIRA robot—An ultrasound image-guided lung brachytherapy system . . . . .	15
3	ROBOTIC SYSTEMS FOR BRACHYTHERAPY . . . . .	4	4	ROBOTIC SYSTEM CLINICAL WORKFLOW . . . . .	16
	3.A Historical background . . . . .	6	4.A	Preliminary preparations . . . . .	16
	3.B Current robotic systems . . . . .	7	4.B	Preoperative setup . . . . .	16
	3.B.1 Elekta-Nucletron FIRST (Oncentra Integrated Prostate Solution) system . . . . .	7	4.C	Anatomic assessment . . . . .	16
	3.B.2 EUCLIDIAN (TJU)—An ultrasound image-guided prostate brachytherapy system . . . . .	9	4.D	Dosimetric planning . . . . .	16
	3.B.3 MIRAB (TJU)—An ultrasound image-guided prostate brachytherapy system . . . . .	9	4.E	Execution . . . . .	16
	3.B.4 UMCU robot—A MRI-guided prostate brachytherapy system . . . . .	9	4.F	Exception handling . . . . .	17
	3.B.5 UW robot—An ultrasound image-guided brachytherapy system . . . . .	10	4.G	Real-time plan readjustment . . . . .	17
	3.B.6 JHU robot1—An ultrasound image-guided prostate brachytherapy system . . . . .	11	4.H	Reporting . . . . .	17
	3.B.7 JHU MrBot—A MRI-guided prostate brachytherapy system . . . . .	12	4.I	Postimplant cleaning and decontamination . . . . .	17
	3.B.8 JHU robot3—A MRI-guided prostate brachytherapy system . . . . .	13	4.J	Postimplant dosimetric evaluation . . . . .	17
	3.B.9 JHU and BWH—A MRI-guided prostate brachytherapy system . . . . .	14	5	ROBOTIC SYSTEM SAFETY . . . . .	18
	3.B.10 UBC robot—An ultrasound image-guided prostate brachytherapy system . . . . .	14	6	COMMISSIONING . . . . .	19
	3.B.11 RRI robot—An ultrasound image-guided prostate brachytherapy system . . . . .	14	6.A	Commissioning of robotic equipment . . . . .	19
			6.B	Commissioning of the clinical procedure . . . . .	21
			7	QUALITY MANAGEMENT . . . . .	21
			8	RECOMMENDATIONS . . . . .	21
			9	CONCLUSIONS AND FUTURE PERSPECTIVES . . . . .	22
			A	APPENDIX A: DEFINITIONS AND NOMENCLATURES . . . . .	22
			B	APPENDIX B: TEST PROTOCOL . . . . .	23
			1	Test procedures for evaluating performance of brachytherapy robots . . . . .	23
			a	Purpose . . . . .	23
			b	Materials . . . . .	23
			c	Methods . . . . .	23
			d	Data analysis . . . . .	23
			e	Results . . . . .	24

C APPENDIX C: EXAMPLE OF QA PROCEDURE .....	24
--	----

## 1. INTRODUCTION

The current paradigm for interstitial implantation or temporary placement of encapsulated radioactive seeds in a tumor volume results in a highly conformal dose distribution covering the target volume characterized by a steep fall-off of dose outside.<sup>1</sup> For these reasons, it is an effective treatment for a variety of tumor sites such as early-stage prostate cancer, lung cancer, liver cancer, breast cancer, and so on. However, it requires both the use of real-time image guidance and a high degree of skill on the part of the physician or surgeon in needle insertion and accurate seed placement. In addition, interstitial brachytherapy is an invasive procedure that requires handling of radioactive materials, resulting in unavoidable exposure to medical personnel.

Early applications of interstitial brachytherapy employed direct manual handling of radioactive seeds and on-the-fly optimization of seeds placement that limited the time a physician could spend in executing the implant. A major advance in this area was pioneered by Henschke *et al.* with the development of afterloading techniques, wherein hollow needles were placed at optimal locations in the tumor volume, and radioactive seeds in ribbons or wires were subsequently inserted in the needles or catheters.<sup>2-4</sup> This led to a major reduction in the time physicians were exposed to radiation. The next important development occurred in the 1970s when remote afterloading systems were introduced. In these systems, the sources were controlled remotely and could be retracted back into a safe if the medical team needed to attend to the patient. This further reduced radiation exposure to the medical staff.

Medical robots are a small but growing subgroup of industrial robots. In this report, we focus on the clinical implementation of robotic systems for interstitial brachytherapy. Most of the applications of robotic brachytherapy technology have been in the implantation of seeds in patients with early-stage prostate cancer. Nevertheless, the techniques apply to any clinical site where interstitial brachytherapy (both low-dose-rate and high-dose-rate) is appropriate. For example, one of the brachytherapy robots described in this report has been used for lung cancer, and clinical investigations are under consideration for other sites such as liver.<sup>5-8</sup>

In the last decade, there have been significant increases in the use of robotic systems and automation tools in brachytherapy. Several groups have adapted and integrated such systems and tools into conventional brachytherapy procedures, with the shared goals of achieving higher precision and accuracy in seed placement, improving dose distributions, minimizing surgical trauma, and further reducing radiation exposure to staffs. This report reviews the state-of-the-art in the field of robotic interstitial brachytherapy. The American Association of Physicists in Medicine (AAPM) Brachytherapy Subcommittee and Therapy Physics Committee, as well as the Groupe Européen de Curiethérapie-

European Society for Radiotherapy & Oncology (GEC-ESTRO) BRAPHYQS Subcommittee, have reviewed and approved this report, and thus it represents AAPM and GEC-ESTRO guidelines for the clinical evaluation and implementation of this new approach to brachytherapy.

## 2. CLASSIFICATIONS OF ROBOTS

The Robotics Institute of America (RIA) defines a robot as a “reprogrammable multifunctional manipulator designed to move materials, parts, tools, or specialized devices through variable programmed motions for the performance of a variety of tasks.”<sup>9</sup> There is no consensus on which machines qualify as robots, but there is a general agreement among experts and the public that robots tend to do some or all of the following: move under their own power, operate a mechanical limb or similar part, sense and manipulate their environment, and exhibit intelligent behavior, especially behavior which mimics humans or other animals. The RIA subdivides robots into four classes:

- Class 1. Devices that manipulate objects with manual control.
- Class 2. Automated devices that manipulate objects with predetermined cycles.
- Class 3. Programmable and servo-controlled robots with continuous point-to-point trajectories.
- Class 4. Robots of the last type (Class 3) that also acquire information from the environment and move intelligently in response.

Control systems of brachytherapy robots may have varying levels of automation and autonomy. Although frequently the terms are used interchangeably, the concepts of *automation* and *autonomy* have highly distinct meanings. Simply, automation is the process of transferring activity from unaided human labor to hardware and software systems. More precisely, “Automation is the automatically controlled operation of an apparatus, a process, or a system by mechanical or electronic devices that take the place of human organs of observation, decision, and effort”; and, robots are defined as automatic devices that perform such tasks.<sup>10</sup> All of the brachytherapy systems presented in Sec. 2 of this report satisfy this definition in that they perform certain component tasks in the brachytherapy procedure automatically by following a programmed instruction set. Automation can lead to performance gains in terms of mechanical advantage, precision, reliability, or safety.

Autonomy, on the other hand, is a process of function allocation that is independent of whether the actor is human or robotic. Autonomy is a process by which control decisions are allowed and managed in a distributed operations environment. Autonomy by an automatic system is evaluated by whether the system is authorized to perform actions with or without human intervention or oversight. This process is considered one of function allocation and has been described as “degrees of automation” by Sheridan<sup>9</sup>—perhaps adding to the potential confusion. In essence, two questions



must be asked: *Autonomy from whom?* and *Autonomy to do what?* Sheridan describes five critical domains of function oversight: plan, teach, monitor, intervene, and learn. These five functions must be performed in addition to the actual operation of the automated process. A fully autonomous robot must be able to execute the automated process, and manage all five oversight functions, accurately and safely (for the robot and any human actors) without real-time control or intervention by the human supervisory controller.

In the case of a brachytherapy robot, the autonomy challenge is for the robot to conduct treatment planning, monitor treatment progress, intervene in the case of patient movement, or needle misplacement, and obtain feedback from prior treatments to modify the robot's programming (learn and teach itself) for future performance. The *Autonomy from whom?* question directly addresses to what degree the robot will be permitted to conduct its operations without real-time oversight by the medical physicist or physician. The *Autonomy to do what?* question may then be described in terms of the tasks of treatment execution, as well as the oversight functions of treatment planning, monitoring, intervention, and learning or teaching based performance modification.

A new classification of system that accounts for interactions between human control and the machine motions may help explain the role of brachytherapy robots. This classification is appropriate for brachytherapy robots and different from the previously mentioned RIA classification.

- Level I. A human controls each movement; each machine actuator change is specified by the operator. Most surgical robots fall into this category.
- Level II. A human specifies general moves or position changes and the machine decides specific movements of its actuators. Some brachytherapy robots fall into this category.
- Level III. The operator specifies only the task; the robot manages to complete it independently. Developers of some advanced brachytherapy robots are working to achieve this level of autonomy.
- Level IV. The machine will create and complete all its tasks without human interaction. This level of autonomy is beyond the capability of current brachytherapy devices.

The above-mentioned classifications are illustrated with a few well-known medical robots. The da Vinci™ robot (Intuitive Surgical, Inc., Sunnyvale, CA) is used for radical prostatectomy surgery frequently in the United States and for low-dose-rate (LDR) brachytherapy seed implants into the bladder frequently performed in the Netherlands. This robot is a manipulator, following the movements of the surgeon's hands with no programming or automatic function, making it a teleoperation or Class 1 robot operating at Level I. The ultrasound robot listed here as JHU Robot1 is composed of a manipulator that positions a needle guide in place for insertion of a brachytherapy needle. Because the robot executes coordinates generated by an optimization guided by the human operator for needle insertion, but allows for the physician to insert the needle, it falls

under Level II. The CyberKnife™ (Accuray, Inc., Sunnyvale, CA) is an image-guided stereotactic radiosurgery system that consists of a compact linear accelerator mounted on a robotic arm.<sup>11,12</sup> It allows the external radiation beam to be directed to a target in the body from any direction within the robot's workspace according to a predefined treatment plan while dynamically adjusting for patient movement. Once the treatment has started, the CyberKnife completes the task without human interaction making it a Level III robot. No currently available medical robot has full autonomy, i.e., none are classified as a Level IV.

A robot may also be characterized by its motions. The majority of industrial and educational robots, as well as some medical robots (e.g., CyberKnife™) are some variations of the PUMA (*Programmable Universal Machine for Assembly*) robot, which was designed by Victor Scheinman in 1975 and the first prototype was developed in 1978 for General Motors (Unimation, Inc., Danbury, CT).<sup>13</sup> The PUMA robot is an articulated arm, i.e., manipulator that emulates the characteristics of a human arm with only rotational joints and no translational joints (Fig. 1). Most of the current brachytherapy robots have rectilinear configurations (translational motions) with some capabilities of needle angulation and/or rotation, which are significantly different from PUMA robots that have only rotational joints.

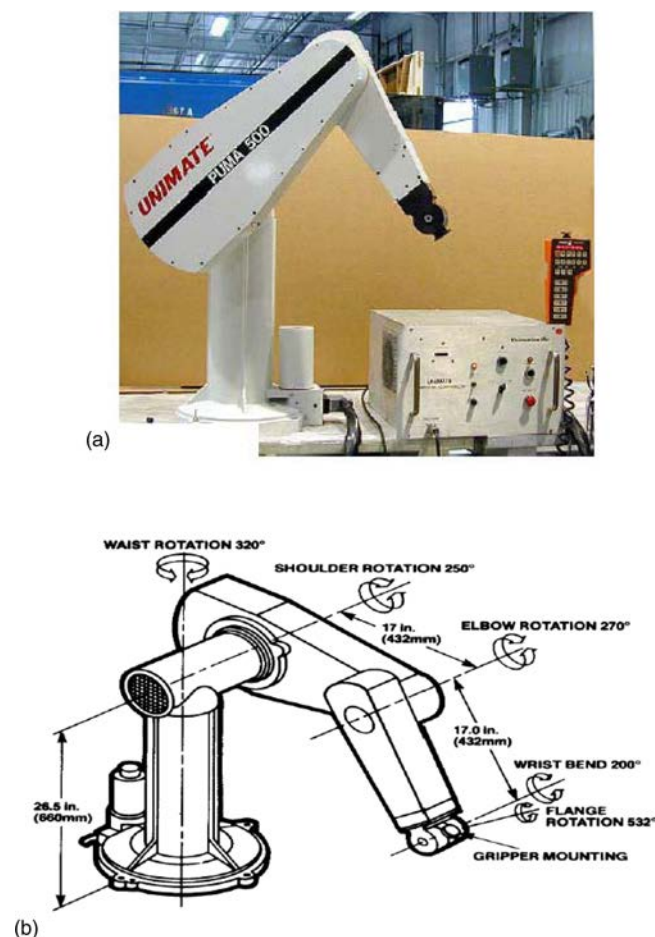

FIG. 1. PUMA robot from Unimate. (a) Exterior view with controller box and (b) schematic of movement, i.e., degrees of freedom.

Certain commercial and noncommercial equipment, instruments, and materials are identified in this work in order to adequately describe the field of robotic brachytherapy. Such identification does not imply recommendation nor endorsement by the AAPM or GEC-ESTRO, nor does it imply that the material or equipment identified is necessarily the best available for this purpose. In Sec. 3, we describe several brachytherapy robots and critical clinical decision points that help determine appropriate allocations of function (and resulting autonomy) in the clinical environment.

### 3. ROBOTIC SYSTEMS FOR BRACHYTHERAPY

At the time of this publication, commercial robots are not readily available for brachytherapy applications, except the Oncentra Integrated Prostate Solution system from Elekta-Nucletron (Veenendaal, the Netherlands), a Level II device, that delivers seeds by a motorized means. Several custom-made robotic systems have been developed or are being developed at different research institutes and hospital settings. These robotic systems, in some combination, insert a surgical tool (needle) and deliver or place radioactive seeds. During the procedure, they come in contact with patients and operate in close proximity to the staff. Therefore, safety, accuracy, user-friendliness, and reliability (SAUR) criteria need to be satisfied for any robotic brachytherapy system.

The functional requirements of the system are to provide the following:

- (1) safety for the patient, clinicians, and the operating room (OR) staff and equipment,
- (2) ease of cleaning and decontamination,
- (3) compatibility with sterilization of components,
- (4) methods for the clinician to review and approve the planned dose distribution and planned robot motions before needle placement,
- (5) visual (mandatory) and force (optional) feedback during needle insertion,
- (6) visual confirmation by the chosen imaging technique of each needle-tip placement and seed deposition,
- (7) provision for reverting to conventional manual brachytherapy at any time,
- (8) quick and easy disengagement in case of emergency,
- (9) robust and reliable operation, and
- (10) ease of operation in the procedure environment.

The robotic systems designed and developed for brachytherapy are also expected to enhance the quality of care. To do this, a robotic system is expected to meet the following main objectives:

- (1) improve accuracy of needle placement and seed delivery (i.e., place the needle and seed correctly at the planned location),
- (2) improve consistency of seed implantation procedure (i.e., eliminate interclinician variability),
- (3) improve avoidance of critical structures (e.g., for prostate implants, urethra, pubic arch, rectum, bladder, structures of the penis),

- (4) improve dose optimization,
- (5) reduce the clinician's learning curve,
- (6) reduce clinician fatigue,
- (7) reduce staff radiation exposure, and
- (8) streamline the brachytherapy procedure.

To achieve the above-mentioned objectives, thoughtful consideration is required even at the conceptual design stage and thereafter during design and development phases. As an example, the dorsal–lithotomy position for transperineal prostate brachytherapy limits the available workspace for the robotic system (Fig. 2). This workspace may be less than 120 mm in the lateral direction and may be even less for robots to be used in an magnetic resonance (MR) scanner.<sup>13–16</sup> Thus, robots may lose dexterity or degrees of freedom (DOFs) and encounter singularities (inaccessible positions) while working in such a severely constrained workspace. Moreover, the robotic system should be compact to ensure the clinician's work environment is not affected. Successful clinical implementation of a robotic system critically depends upon the shape and size of the robot.

While the constrained workspace dictates that the mechanical structure of the robot be compact, the robot must be robust enough to insert a needle safely and accurately in the patient for the brachytherapy procedure. Studies revealed that maximum reaction forces on needles for insertion in human prostates during LDR brachytherapy are about 10 and 15 N for 18-gauge and 17-gauge needles, respectively.<sup>17–19</sup> These forces were experienced in the perineal tissue region. However, the prostate capsule puncturing force can be about 8 and 11 N (maximum) for the above-mentioned types of needles.<sup>17</sup> The design of a brachytherapy robotic system needs to consider this reaction force along with safety factors of 3–5 times the aforementioned forces.<sup>20,21</sup>

Various studies have indicated that needle rotation during insertion can reduce the insertion force and improve targeting accuracy by reducing deformation and displacement of the needle and the target or organ.<sup>22–24</sup> However, tissue damage and associated clinical implications may need to be assessed.

Recent work discusses the effect of damage to the pelvic structures involved in erectile function. Of particular concern is damage to the neurovascular bundles, penile vasculature, and cavernosal structural tissue.<sup>25</sup> While imaging the vasculature and nervous structures around the penis and prostate is difficult, there are a number of techniques that show some promise.<sup>26,27</sup> These structures can be difficult to avoid using conventional rectilinear needle geometries and techniques. With the additional degrees of freedom for needle insertion that the robots allow, clinicians can consider the avoidance of structures other than the standard rectum, bladder, and urethra. There has been some work exploring the additional degrees of freedom that robots allow in the context of avoiding structures in the base of the penis, but there is much more to be explored.<sup>28</sup> With the advancement of imaging, robotic systems may be capable of incorporating features such as real-time image-based semiautomated or automated interventions using additional degree of freedom. The design of robotic devices should consider what advances in imaging

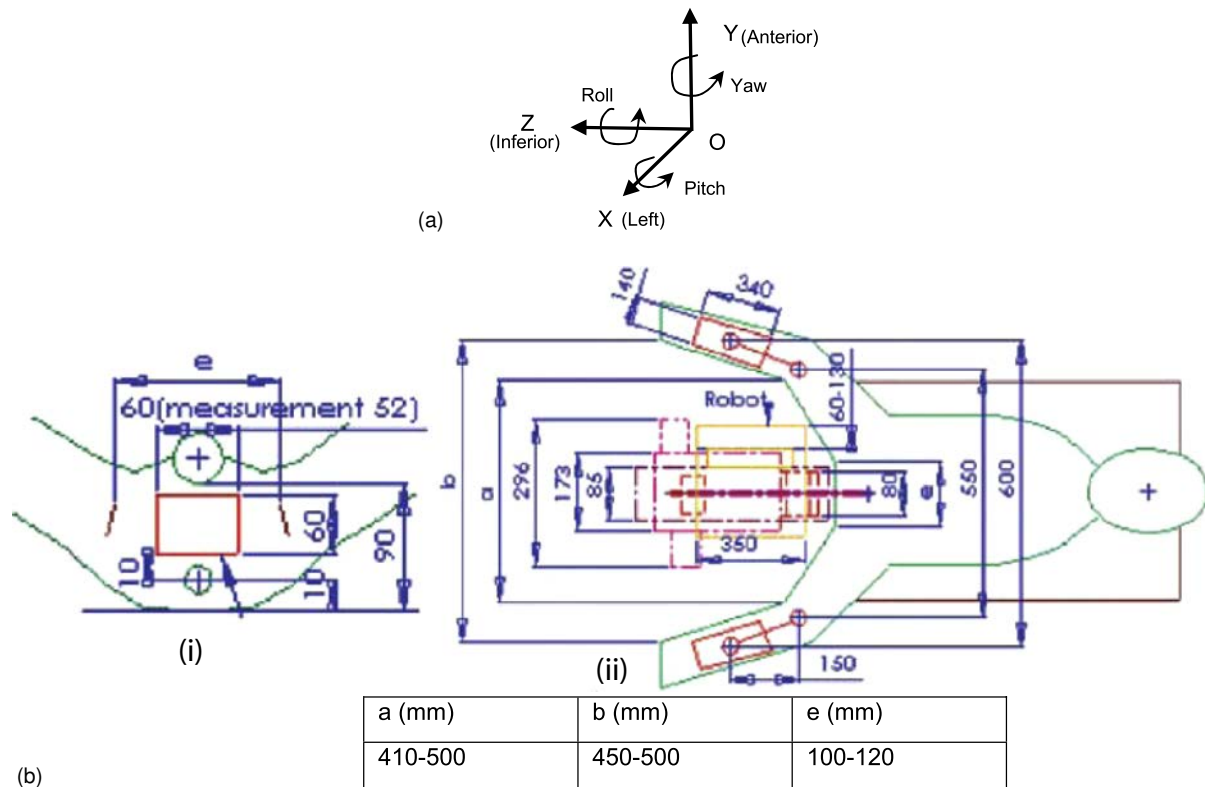

FIG. 2. (a) Reference coordinate system while the patient is in supine position. (b) Workspace for robotic insertion of brachytherapy needle: (i) front view and (ii) top view.

technology will allow in the near future and incorporate into their design features to take full advantage of this added information.

Device cleaning and decontamination pose considerable challenges in medical system design and development. For any brachytherapy robot, the needle and source passages must be sterilizable. Moreover, the whole robot should have provisions for easy and adequate cleaning and decontamination. Robotic brachytherapy systems become more complicated with the addition of sensors (such as force–torque sensors) and other electronic components.<sup>29,30</sup> Therefore, all these issues and suitable solutions should be planned during the design phase of the robotic system. These issues can be critical for regulatory approval and clinical applications.

The International Electrotechnical Commission (IEC) provides useful guidelines for medical devices. Compliance with IEC 60601-1 requires that the manufacturers or the developers have a risk management process in place.<sup>31</sup> It is important for a brachytherapy robotic system to comply with IEC collateral standard for electromagnetic compatibility requirements and tests (IEC 60601-1-2). Information about the compliance with IEC 60601-1 standard can be obtained from the vendors or the manufacturers, if applicable. If the robotic system is approved by the U.S. Food and Drug Administration (FDA), then the system must be IEC 60601-1 or CE (Conformité Européenne) compliant (as appropriate). Similarly, products for medical use in the market of the European Union are required to have a CE marking. More

details about guidelines or requirements in this regard are expected in the planned AAPM Task Group 167 report.<sup>32</sup>

### 3.A. Historical background

The first motorized source positioning systems, i.e., remote afterloading systems, were clinically introduced for brachytherapy in the early 1980s.<sup>33–36</sup> However, they do not qualify as robotic systems.<sup>9</sup>

In 2001, a seed implantation system featuring automated XYZ motion with a seed cartridge was proposed by Elliott *et al.*<sup>37</sup>

In 2002, Fichtinger *et al.* explored the use of computer tomotherapy (CT)-guided robot assistance for prostate biopsy and therapy.<sup>38</sup> They demonstrated a CT-couch-mounted system for transperineal needle guidance comprising a passive arm with 7DOF and a robot that can angulate the needle about its tip. Later in 2007, Fichtinger *et al.* proposed a 4DOF system for ultrasound-guided robot-assisted prostate brachytherapy.<sup>39</sup> Clinical feasibility and performance of this system were reported in 2011.<sup>40</sup> This robot is compatible with commercially available conventional template mounting systems.

In 2004, Wei *et al.* reported an evaluation of robotic needle insertion for prostate brachytherapy using a commercial industrial robot.<sup>41</sup> The same group reported a compact 4DOF robotic needle guide having a closed cylindrical/closed kinematic chain with 13 linkage elements and brakes.<sup>42</sup>



Also in 2004, Davies *et al.* described a possible robotic approach to prostate brachytherapy.<sup>43</sup> They reported an XYZ robot with needle rotation, but no needle angulation. Preliminary tests of their needle driver system were presented; these were carried out with a commercial manufacturing robot.

In 2005, a 6DOF robotic system for use in prostate brachytherapy was reported by Meltsner *et al.* This application described an XYZ-theta robot capable of placing a needle guide at an arbitrary location with an arbitrary angle in order to provide angulated (around the axis of insertion) needle insertion at a desired position and orientation.<sup>44</sup> The system allows the physician to load needles through the guide. In addition, it provides for automatic deposition of the seeds at programmed spacing along the needle track. Automation of a number of tasks was also discussed.<sup>45</sup>

In 2006, Yu *et al.* reported a transrectal ultrasound (TRUS) image-guided 6DOF prostate brachytherapy robotic system.<sup>46</sup> This robot can rotate the brachytherapy needle about its own axis to reduce the force necessary for insertion and thereby improve needle placement and seed delivery accuracy. This robot is equipped with three force–torque sensors enabling closed-loop control of the system. The concept of using a rotating needle to reduce the surgical trauma to the tissues was employed in the robot developed.<sup>22</sup>

Later in 2006, Bassan *et al.* reported a macro–micro approach including a 5DOF remote center-of-compliance robot arm supported by a passive arm. The system featured back-drivable joints with redundant sensing.<sup>47,48</sup>

In 2008, Salcudean *et al.* developed a 4DOF robotic system. This robot can place the needle at the patient's perineum with the capability of angulating the needle in sagittal and coronal planes.<sup>49</sup>

In 2010, Podder *et al.* developed a 6DOF multichannel robotic system that can insert and rotate 16 needles simultaneously. This system is capable of delivering seed sources autonomously.<sup>50,51</sup>

Several other groups have reported development of image-guided needle-insertion systems that use fluoroscopy, CT, and magnetic resonance imaging (MRI).<sup>7,15,52–57</sup> While most of the image-guidance approaches presented before have only relied upon 3D geometric models of tissue, deformation models have started to be used for needle planning, first in 2D, then in 3D.<sup>58–60</sup> Needle–tissue interaction models continue to be developed based on fluoroscopic and ultrasound imaging.<sup>61–63</sup> Some other research groups are developing smart needling devices for improving geometric conformality, avoiding critical structures, and improving clinical benefits.<sup>64–70</sup>

### 3.B. Current robotic systems

In image-guided brachytherapy (IGBT), TRUS, CT, and MRI are used. Among these, MRI provides the best soft tissue contrast. CT and MR images allow dose planning based on anatomy not distorted by a TRUS probe (i.e., as it will be for the dose delivery). TRUS, however, is most commonly used due to cost effectiveness and ease of availability in a wide range of hospital settings. There exist a total of 13

robotic systems around the world of which the authors have any knowledge. It is expected that number will increase in the near future. Some of these robots have a high level of autonomy for inserting the brachytherapy needles as well as in delivering the seeds automatically. These procedures are performed under the supervision of an authorized physician. All these robotic systems, except the FIRST system, eliminate the use of a physical template, thus improving the maneuverability of needle insertion, which potentially results in enhanced accuracy and avoidance of pubic arch interference. Details of these 13 robotic systems for interstitial brachytherapy are presented below and a summary is provided in Table I. Systems that were available by January 1, 2012 for evaluation by the TG-192 committee are included in this table. As of writing, only the FIRST, EUCLIDEAN, and JHU1 robotic systems have been used on patients for clinical brachytherapy. As later described, some systems are for LDR seed brachytherapy, high-dose-rate (HDR) brachytherapy, or both modalities.

#### 3.B.1. Elekta-Nucletron FIRST (Oncentra Integrated Prostate Solution) system

In 2002, Nucletron (Elekta-Nucletron, Veenendaal, the Netherlands) released an integrated system, Fully Integrated Real-time Seed Treatment (FIRST™), that included a robotic seed delivery and needle retraction device called Oncentra Seeds.<sup>15</sup> This system combines a computer-controlled 3D transrectal ultrasound system, the above-mentioned robotic device, and the Oncentra Seeds treatment planning system (TPS). This product received FDA and Health Canada approvals in 2001 and CE approval in 2002.

The robotic portion of the Oncentra Seeds system is a compact device that is mounted on the same support unit as the TRUS probe (Fig. 3). It performs real-time seed delivery through manually placed needles and a TPS that allows modification of the seed loading at any time during the delivery process, taking into account the previously delivered seeds. Oncentra Seeds builds seed:spacer sequences (nonstranded) from separate magazines. A drive wire is used to expel the seeds and spacers from the magazines. A diode detector measures seed strengths. Another 15 detecting positions are further used for the validation of the complete sequence length and individual components before delivery into the patient. The drive wire then delivers the seed train into a previously manually implanted needle through a transfer tube connected to the needle. The system delivers the sequence with the first seed at its reference depth within the prostate. A small robotic arm then retracts the needle automatically outside the prostate capsule, keeping the drive wire in place to avoid suction from the retraction of the needle pulling the seed train out of position. Once the robotic retraction is performed, the drive wire is retracted and the needle can be disconnected from the transfer tube and removed. The system is ready for the next insertion or further plan modification. The system can drive the TRUS probe automatically to the plane of the needle to be inserted and/or seed delivered. The Oncentra Seeds accuracy has been extensively tested by



TABLE I. Summary of the currently available robotic brachytherapy systems.

Features Institute/lab	FIRST Elekta-Nucletron	EUCLIDIAN TJU	MIRAB TJU	UMCU UMCU	UW robot UW	JHU1-robot1 JHU	JHU2- MrBot JHU	JHU3- MR JHU	JHU and BWH-MR JHU	UBC UBC	RRI RRI	CHUG CHUG	MIRA-V UWO
RIA class	2	3	3	2	3	2	2	2	2	3	3	5	3
Autonomy	Level II	Level III	Level III	Level II	Level II	Level I	Level III	Level II	Level II	Level II	Level II	Level II	Level II
Application	PSI	PSI	PSI/HDR	PSI/HDR	PSI/HDR	PSI	PSI	PSI	PSI	PSI	PSI	PSI	LSI
Imaging modality	U/S (auto and manual)	U/S (auto and manual)	U/S (auto and manual)	MR	U/S (manual)	U/S (manual)	MR	MR	MR	U/S (manual)	U/S (auto and manual)	U/S	U/S
DOFs	2DOF	5DOF surgical, 2DOF U/S, 6DOF positioning, 3DOF cart	5DOF surgical, 2DOF U/S, 6DOF positioning, 3DOF cart	5DOF	6DOF	4DOF surgical	4DOF	3DOF	6DOF	4DOF surgical	U/S (auto and manual)	5DOF	5DOF
Number of channel/needle	Single	Single	Multiple	Single	Single	Single	Single	Single	Single	Single	Single	Single	Single
Needle insertion	Manual	Autonomous	Autonomous	Autonomous tapping	Auto and/or manual	Manual	Autonomous			Manual	Manual	Autonomous	Manual
Needle rotation	No	Yes	Yes	No	Yes	No	No	No	No	No	Manual	Yes	No
Angled insertion	No	Yes	Yes	Yes	Yes	Yes	No	Yes	Yes	Yes	Yes	Yes	Yes
Seed delivery	Autonomous	Autonomous	Autonomous	Manual	Manual (auto in research)	Manual	Autonomous	Manual	Manual	Manual	Manual	Manual	Manual
Needle withdraw	Autonomous	Autonomous	Autonomous	Manual	Auto and/or manual	Manual	Autonomous	Manual	Manual	Manual	Manual	Manual	Manual
Physical template	Yes	No	Yes	No	No	No	No	No	No	No	No	No	No
Template/perineum area coverage	Conventional	62 × 67 mm	60 × 60 mm	—	250 × 250 mm	50 × 50 mm	40 × 40 mm	N/A	50 × 50 mm	150 × 150 mm	60 × 60 mm	105 × 105 mm	—
Depth movement	Conventional	312 mm	240 mm	150 mm	250 mm	120 mm	40 mm	—	120 mm	150 mm	70 mm	—	—
TPS	Oncentra Seeds	In-house, FDA–IDE approved	In-house	—	—	FDA approved Interplant®	—	—	none	—	In-house	—	—
Needle-tip positioning accuracy in air	N/A	<0.2 mm	<0.2 mm	—	—	—	0.32 mm	—	0.94 mm	<0.3 mm	0.2 mm	—	<0.5 mm
Needle-tip positioning accuracy in phantom	<0.5 mm	<0.5 mm	<0.5 mm	—	—	1.04 mm	<0.5 mm	2.0 mm	3.0 mm	—	0.9 mm	1.0 mm	0.9 mm
Accuracy in seed deposition	<1 mm (tested)	<1 mm (tested)	<1 mm	—	<1 mm	—	<1 mm	—	—	1.2 mm	1.6 mm	—	—
Emergency stop	Yes	Yes	Yes	Yes	Yes	Yes	Yes	Yes	Yes	Yes	Yes	Yes	Yes
Provision for reverting to conventional mode	Yes	Yes	Yes	No	Yes	—	—	—	—	—	Yes	—	—
Force–torque sensor	No, but motor stops during retraction if too much strength is needed	Yes	No	No	Yes	No	No	No	No	No	No	No	No
FDA approval	Yes, also CE	IDE	No	No	No	No	No	No	No	No	No	No	No

Note: PSI, prostate source implantation; LSI, lung source implantation.

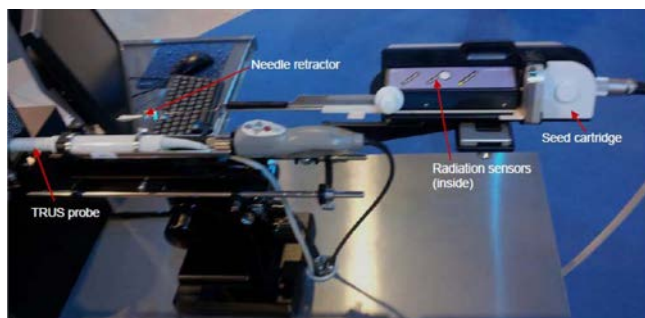

FIG. 3. Oncentra prostate solution, i.e., seedSelectron. Motorized TRUS motion, seed deposition, and needle withdrawal.

Rivard *et al.*<sup>71</sup> while the clinical performance of the complete system has been reported by Beaulieu *et al.*<sup>72</sup> and Moerland *et al.*<sup>73</sup> Seed placement accuracy in phantom is about 1 mm.

### 3.B.2. EUCLIDIAN (TJU)—An ultrasound image-guided prostate brachytherapy system

The robotic system developed in the Department of Radiation Oncology at Thomas Jefferson University (TJU, Philadelphia, PA) named Endo-Uro Computer Lattice for Intratumoral Delivery, Implantation, and Ablation with Nanosensing (EUCLIDIAN) consists of five main modules. They are surgical module—having a 2DOF TRUS driver, 3DOF gantry robot, 2DOF needle inserter, 6DOF positioning module, and 3DOF cart with electronic housing (Fig. 4).<sup>13,30,46</sup> All motions of the EUCLIDIAN's surgery module are achieved using motors fitted with high-resolution optical encoders and gearboxes. The TRUS probe can be translated and rotated automatically and can also be operated manually for acquiring images with a minimum separation of 0.1 mm. The prostate stabilization needle guide of EUCLIDIAN is capable of orienting the needle at any desired angle in the sagittal plane as well as in the coronal plane resulting in improved stabilization of the prostate.<sup>74</sup> The gantry robot has two translational motions (*X*- and *Y*- directions) and one rotational motion in vertical plane (pitching up or down for avoiding pubic arch interference or to reach closer to the rectum). The needle driver equipped with three force–torque sensors (stylet sensor, cannula sensor, and a 6DOF whole needle sensor) is capable of inserting needles and delivering seeds automatically. Additionally, EUCLIDIAN has the provision for needle rotation, which is useful in reducing needle-insertion force and expected to reduce organ/target deformation and displacement.<sup>22–24</sup> Every motion during the sequence of needle insertion and seed delivery is fully automatic as per the dosimetric plan. However, the clinician is able to interrupt and/or manipulate the movements at any time using a user-pendant. In the case of system failure (if the motorized system totally fails), the EUCLIDIAN has a provision for conventional manual mode of operation. This system has a provision for a template holder at the end of the TRUS probe driver, enabling manual takeover if required. After inserting a regular commercial template, the clinician will be able to continue the seed implantation for the patient using the same dosimetric plan.

The 6DOF positioning platform is able to translate and to orient the whole surgical module so that the surgical module is aligned with the patient's anatomical configuration as required. The 3DOF cart provides gross movements of the robotic system to align with the patient while the positioning platform enables finer movement for desired positioning and orientation of the robot in 3D space. Prostate Implant Planning Engine for Radiotherapy (PIPER), an in-house developed genetic algorithm based software, which is approved by the U.S. Food and Drug Administration (FDA), is used for contour delineation, 3D anatomical model generation, dosimetric planning, 3D visualization, and needle tracking.<sup>75,76</sup> Isodose contours can be displayed on transverse, sagittal, and coronal planes that are built from TRUS images. In 3D visualization, various relevant anatomical structures, seeds, needle paths, a virtual template, and the TRUS probe can be visualized. Seeds deposition accuracy in phantom is within 1 mm. Reliability of the EUCLIDIAN system has been evaluated with extensive testing mimicking the procedures in the OR.<sup>30</sup> This system received the FDA's Investigational Device Exemption approval in 2008.

### 3.B.3. MIRAB (TJU)—An ultrasound image-guided prostate brachytherapy system

The Multichannel Image-guided Robotic Assistant for Brachytherapy (MIRAB) developed in the Department of Radiation Oncology at TJU is a 6DOF system consisting of five modules: rotary needle adapter, surgical *XY* carrier, mounting and driving mechanism, seed applicator, and TRUS probe driver (Fig. 5). The MIRAB system is modularized so that it can easily be installed on the EUCLIDIAN system by taking the needling module of the EUCLIDIAN away.<sup>50,51,77</sup> The 2DOF rotary needle adapter can insert 16 needles concurrently with rotational capability. Distal ends of the needles are supported and guided by a multihole supporting plate. The 3DOF surgical *XY* carrier carries the seed applicator that delivers seeds and withdraws needles. The 2DOF mounting and driving mechanism provides translational motion to the needle adapter and surgical *XY* carrier. The seed applicator is employed to expel the seed from the cartridge automatically according to the dosimetric plan. Seed placement accuracy of this system is about 1 mm. The 2DOF TRUS driver was originally developed for EUCLIDIAN. The interchangeability of MIRAB and EUCLIDIAN is very convenient to switch from a single-channel system to a multichannel system. The dosimetric planning software and the robot control software are similar to that used for the EUCLIDIAN system. Deployment of this system for HDR brachytherapy is being investigated.

### 3.B.4. UMCU robot—A MRI-guided prostate brachytherapy system

A research team at the University Medical Center Utrecht (UMCU, Utrecht, the Netherlands) has developed an MR compatible robotic system, which allows online MRI guidance during prostate brachytherapy.<sup>78–81</sup> This robot is made of polymers and nonferromagnetic materials such as brass,

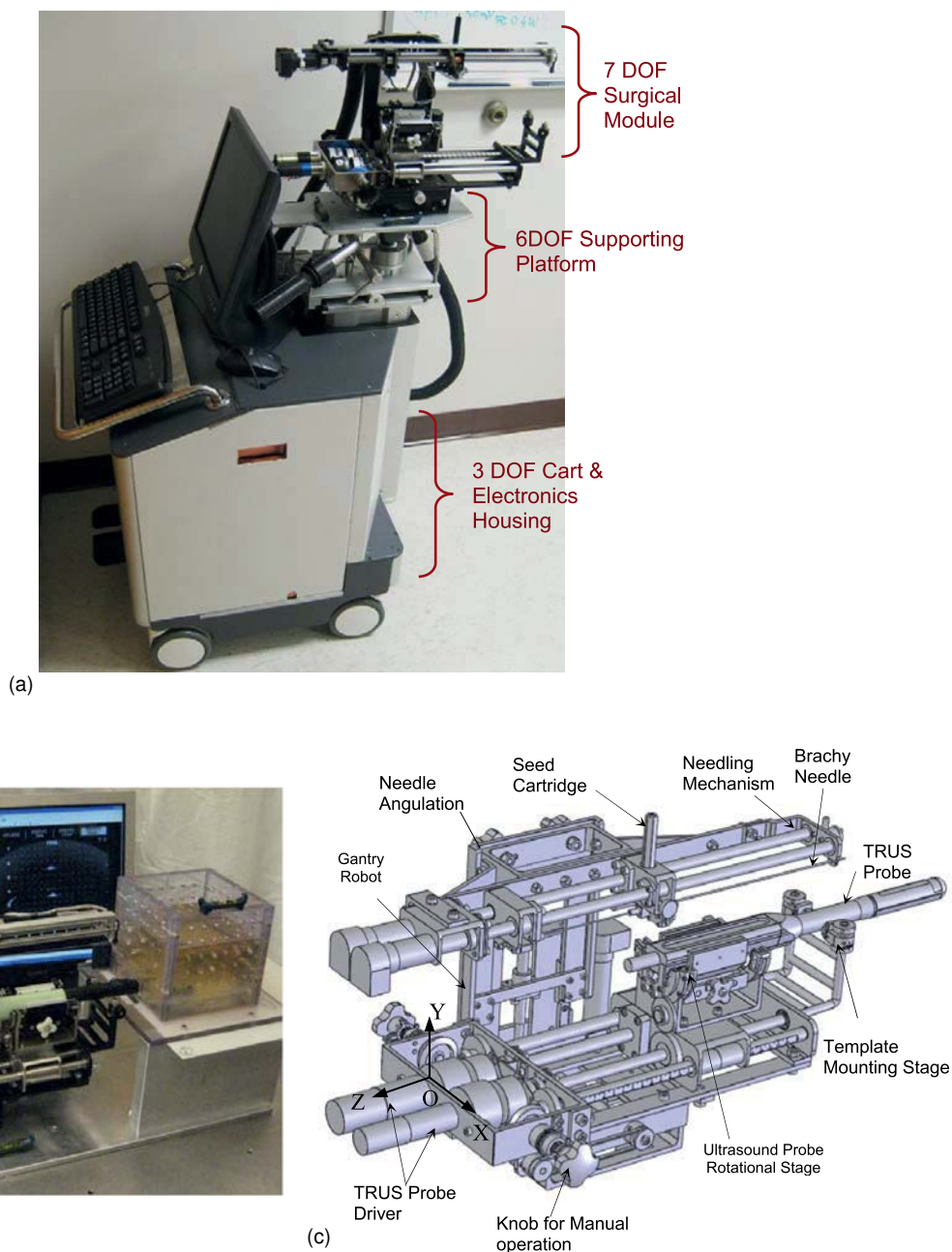

FIG. 4. EUCLIDIAN robot for brachytherapy: (a) three modules are surgical, supporting and, cart and electronic housing; (b) surgical module, planning and control computer, and calibration tools; (c) 3D solidWork design of surgical module.

copper, titanium, and aluminum.<sup>79</sup> The robot fits inside a closed 1.5 T MR scanner. It is fixed to a wooden plate that can slide over the MR table and is placed between the patient’s legs. A clamp is used to hold the system at a chosen position. The robot performs needle tapping but marker deposition is done manually. As a first clinical test, this robot has been used for implanting fiducial gold markers in the prostate of patients undergoing external-beam radiation therapy treatment (EBRT). After this test, the robot was redesigned for prostate HDR <sup>192</sup>Ir brachytherapy with pneumatic and piezoelectric actuators (Fig. 6). The titanium needle is stepwise inserted using a pneumatic-tapping device for reducing organ deformation and improving the needle trajectory control.<sup>78,79</sup> The needle stop is set by a piezoelectric actuator. Positioning

of the tapping-mechanism part of the system is realized with three piezoelectric motors to offer 5DOF. In this way, the entire prostate gland can be reached. The robot performs needle tapping but marker deposition is done manually. Prostate HDR <sup>192</sup>Ir brachytherapy is expected to be the next application.

**3.B.5. UW robot—An ultrasound image-guided brachytherapy system**

The University of Wisconsin (UW, Madison, WI) has developed a prototype brachytherapy robot for automatic and semiautomatic source placement.<sup>24,44,45,82,83</sup> In its current design, the robot is a 6DOF system, comprised of three linear slides, two rotary stages, and a provision for needle rotation.



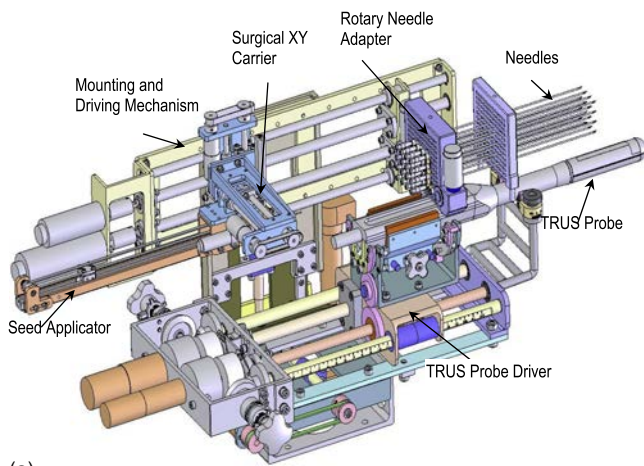

(a)

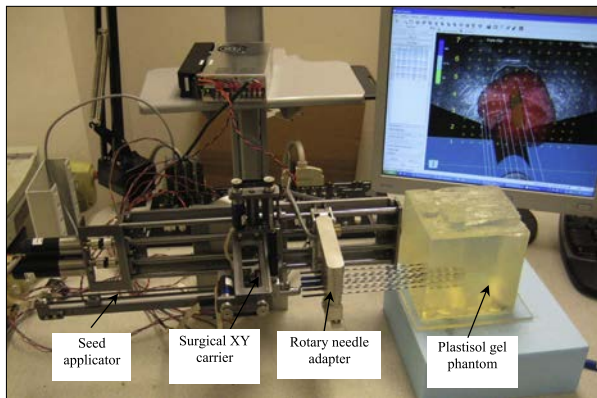

(b)

FIG. 5. (a) 3D SolidWorks design with 2DOF TRUS driver of MIRAB and (b) the prototype of MIRAB with planning system and needle insertion in soft material phantom.

The robot is mounted on a wheeled cart for mobility (Fig. 7). The robot can be tracked in world/fixed coordinates using a 6D magnetic tracking system that reports device position and orientation via magnetic sensors. A sensor can be attached to an ultrasound probe (or other imager) for registration of the imaging plane with the robot workspace. The robot is controlled through a custom written graphical user interface.

Important features of this robot are needle angulation (about  $\pm 30^\circ$ ), rotation (spinning) about its longitudinal axis,

and needle-insertion force measurement. The robot's insertion slide can be decoupled from the motorized slide via manual release. This permits the robot to position the needle for insertion but allows the physician to manually slide the needle assembly into the tissue if desired. This feature was designed to aid in the acceptance of robotics into the clinic. As familiarity and experience increases, the staff may allow a robot to perform the insertions automatically. The measured accuracy of source placement in a gel phantom is about 1 mm.<sup>82</sup>

Future iterations of the device will incorporate automatic source loading and integration with treatment planning software for real-time, intraoperative procedures. The robot will also be explored for use in HDR brachytherapy and other needle-insertion procedures such as biopsies.

### 3.B.6. JHU robot1—An ultrasound image-guided prostate brachytherapy system

The Engineering Research Center and Radiation Oncology Department of Johns Hopkins University (JHU, MD) have developed a robotic system that consists of a TRUS and a spatially coregistered robotic manipulator integrated with an FDA-approved commercial TPS.<sup>39,84</sup> The salient feature of the system is a small 4DOF parallel robot affixed to the mounting posts of the conventional template by removing the template. The robot replaces the template interchangeably and uses the same coordinate system. Established clinical hardware, workflow, and calibration are left intact.

The robot consists of two 2D Cartesian motion stages arranged in a parallel configuration (Fig. 8). The  $XY$ -translational stage provides planar motion relative to the mounting posts in the plane that corresponds to the template face. The  $\alpha\beta$ -rotational stage rides on the  $XY$ -translational stage and can provide needle angulation (about  $\pm 20^\circ$ ) with respect to  $X$ -axis and  $Y$ -axis. The  $XY$ -translational and  $\alpha\beta$ -rotational stages hold a pair of carbon fiber fingers that are manually locked into place during setup. A passive needle guide sleeve is attached between the fingers using free-moving ball joints. The robot functions as a fully encoded stable needle guide, through which the physician manually inserts the needle into the patient. The physician thus retains full control and natural haptic sensing, while the needle is

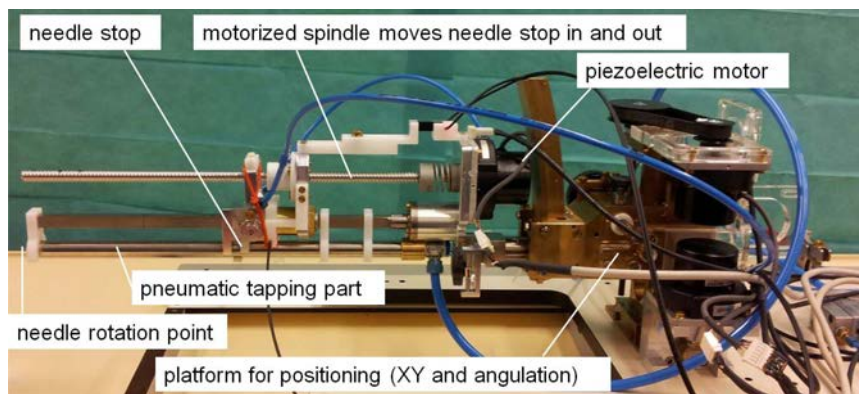

FIG. 6. UMCU MRI-guided robotic system.



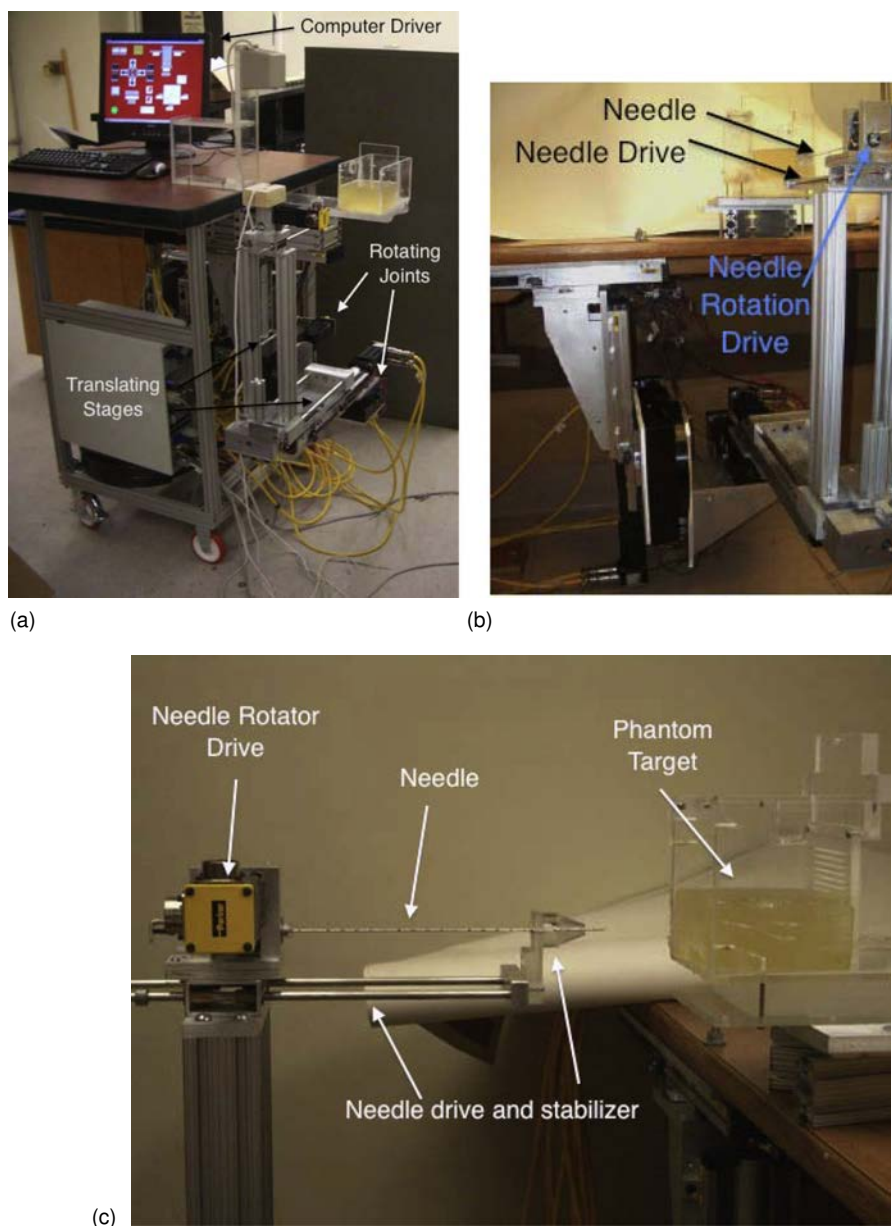

FIG. 7. The UW robot (a) attached to a mobile cart; (b) the robot affixed to a table, for clarity of design; (c) close-up of the needle guide and rotational sixth DOF.

being observed in live transverse and sagittal TRUS, thus ensuring exquisite control of the insertion depth relative to the target anatomy. Nonparallel needle trajectories can be achieved. The needle-tip positioning accuracy measured in TRUS image is about 1 mm.

### 3.B.7. JHU MrBot—A MRI-guided prostate brachytherapy system

The Urology department of JHU has developed a MR compatible, 4DOF robot, named *MrBot*, for transperineal intervention of prostate gland (Fig. 9).<sup>85–88</sup> *MrBot* can accommodate various needle drivers for different percutaneous procedures such as biopsy, thermal ablations, or brachytherapy. Its workspace allows the placement and alignment of

the needle toward any target in the prostate, assuming that initially the robot is roughly aimed toward the prostate.

The system utilizes a new type of motor specifically designed for this application, the pneumatic step motor, *PneuStep*<sup>®</sup> (JHU, Baltimore, MD). The LDR brachytherapy seed-placement mechanism includes a MR compatible needle injector end-effector and non-MR compatible components that are attached to the control cabinet. The seed dispenser is composed of a jar with a funneled bottom that is shaken using a motor, the motor controller, and the LDR seed locking, sending, and counting mechanisms. The seeds are preloaded into the jar and dropped into the funnel as the jar is shaken. The funnel proceeds to a tube leading to the sending system.

*MrBot* is moved such that the needle tip is at the skin entry point and the injector is aligned toward the target. The

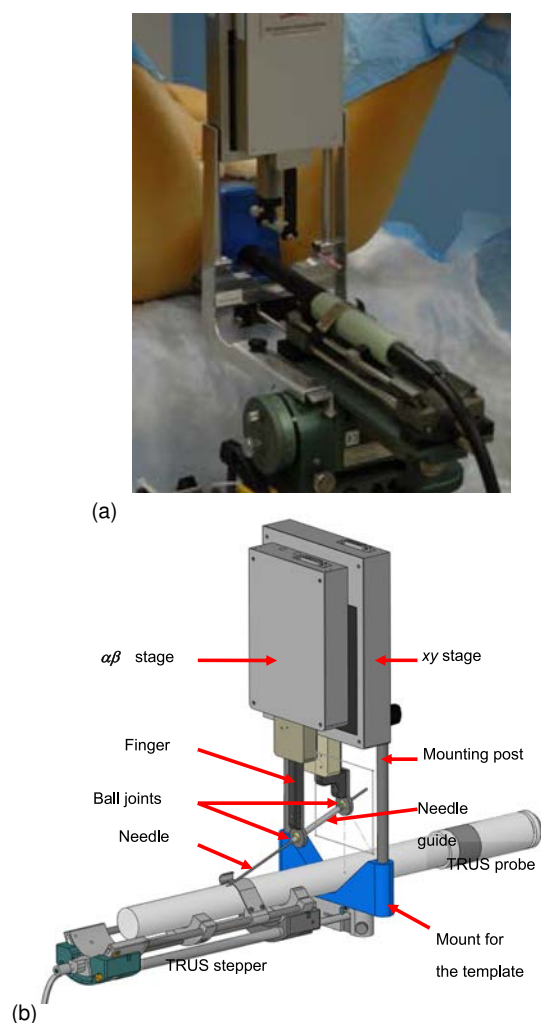

FIG. 8. JHU robot1—U/S image-guided prostate brachytherapy system: (a) the prototype and (b) 3D design. .

insertion depth is set by positioning the needle cylinder with the *PneuStep*<sup>®</sup> motor. The needle is inserted into the prostate by applying pneumatic pressure. The seeds are sent through the feeding tube to injector by applying pneumatic pressure. The actuation, seed sending tube, and sensors are included in the 6 m hose bundle connecting the control cabinet and robot. The described deployment system was implemented and tested with several thousands of seeds. The robotic seed injector ensemble was tested by automatically positioning seeds in agar and *ex vivo* models at arbitrary locations. Then, registration and image-guidance algorithms were integrated to place the seeds at targets specified in the image.

The mean seed placement accuracy in agar models was approximately 1.2 mm with a 0.4 mm standard deviation.<sup>85–88</sup> Motion tests showed reproducibility within a fraction of a millimeter. This robot has been tested under 3 T MRI. The MRI-guided needle targeting experiments showed that the needle tip can be placed within 1 mm of a desired target selected in the image.

The entire robot is built with nonmagnetic and dielectric materials and is designed to perform fully automated

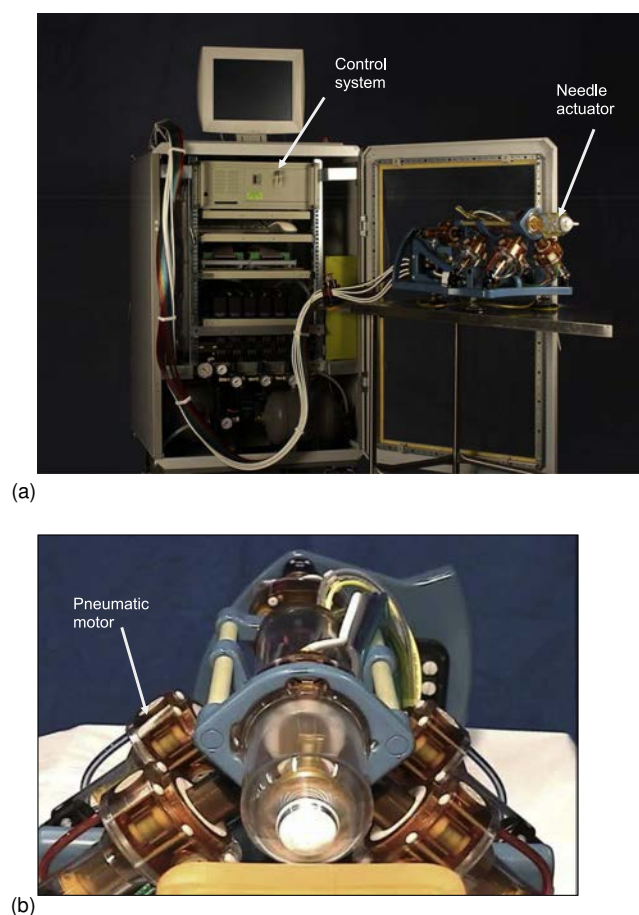

FIG. 9. JHU MrBot—A MRI-guided prostate brachytherapy system: (a) view of whole system containing controller, computer, pneumatic actuators/motors, and robot mechanisms and (b) close-up view of the pneumatic motors of the robot.

brachytherapy seed placement within a closed MR imager. With a 3 T imager, in four dogs, the median error for MR imaging-guided needle positioning and seed positioning was 2 and 2.5 mm, respectively.<sup>86</sup>

### 3.B.8. JHU robot3—A MRI-guided prostate brachytherapy system

The Engineering Research Center and the Department of Mechanical Engineering of the JHU have also developed a remotely actuated manipulator for access to prostate tissue under MRI guidance (Fig. 10). This device provides 3D needle placement with millimeter accuracy under physician control.<sup>89,90</sup> Procedures enabled by this device include MRI-guided needle biopsy, fiducial-marker placements, and LDR brachytherapy seed delivery. Its compact size allows for use in both standard cylindrical and open configuration MRI scanners.

The device is comprised of a rectal sheath, which is placed adjacent to the prostate in the rectum of the patient and a needle guide (containing a curved needle channel). The sheath is held stationary during the procedure while the needle guide rotates and translates within the sheath. The needle exits the needle guide through a window in the sheath at 45° between the axis

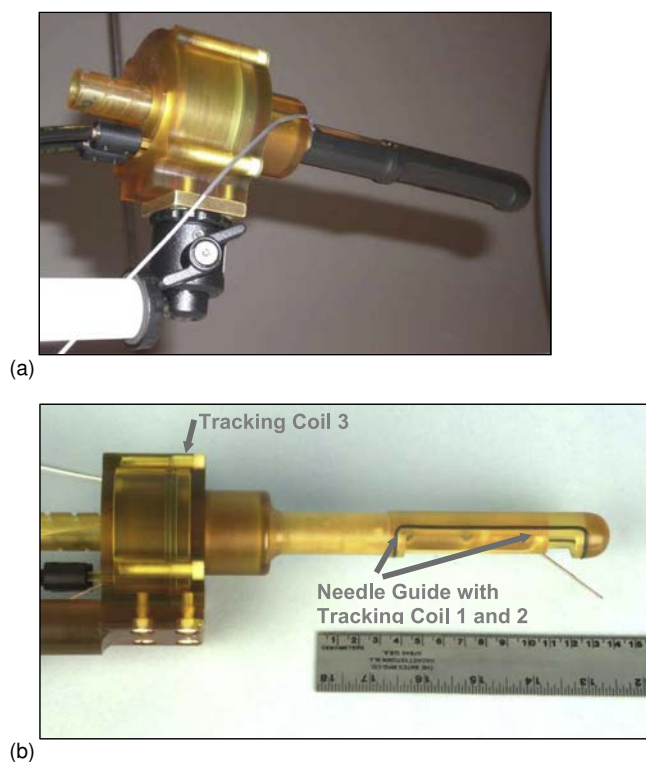

FIG. 10. JHU robot3—MRI-guided prostate brachytherapy system: (a) full view of the system and (b) close-up of the tracking coils and needle guide.

of the guide and the needle for optimal prostate coverage. Rotation and translation of the needle guide and needle insertion are the three DOFs necessary for the manipulator to place the needle at a target within the prostate. The manipulator contains two types of MR coils: an imaging coil and tracking coils for position encoding. The imaging coil is looped around the sheath window, resting in a groove machined into the sheath. Accuracies in fiducial-marker placements in dogs and biopsy procedures with patients were about 2 mm.

### 3.B.9. JHU and BWH—A MRI-guided prostate brachytherapy system

This robot was developed in collaboration by the Engineering Research Center at the JHU and the Department of Radiology at the Brigham and Women's Hospital (BWH, Boston, MA).<sup>91–93</sup> It is a pneumatically operated 6DOF robotic system for placement of a transperineal prostate needle in 3 T closed-bore MRI (Fig. 11). Under remote control of the physician without moving the patient out of the imaging space, the mechanism is capable of positioning the needle for treatment by implanting LDR brachytherapy seeds or for diagnosis by harvesting tissue samples inside the magnet bore.

The patient is positioned in a similar configuration to TRUS-guided brachytherapy, but the MRI bore's constraint (60 cm diameter) requires that the patient legs be spread less and the knees be lowered into a semilithotomy position.

The primary motions of the robot base include two prismatic motions and two rotational motions upon a manual

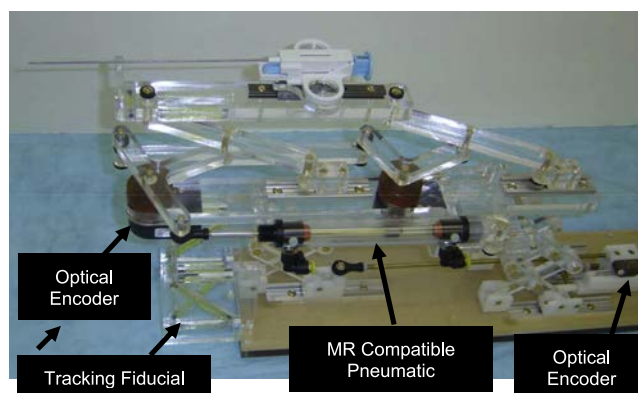

FIG. 11. JHU robot4—MRI-guided prostate brachytherapy system.

linear slide. The slide positions the robot in the access tunnel and allows fast removal for reloading brachytherapy needles or collecting harvested biopsy tissue. In addition to these base motions, application-specific motions are also required; these include needle insertion, cannula retraction, needle rotation, and biopsy gun actuation.

### 3.B.10. UBC robot—An ultrasound image-guided prostate brachytherapy system

The University of British Columbia (UBC, Kelowna, BC, Canada), has developed a 4DOF TRUS-guided robot for prostate brachytherapy (Fig. 12). The robot can translate a needle guide in the  $X$ - $Y$  plane allowing for precise needle insertion along the  $Z$ -direction.<sup>49</sup> The needle can also be angulated about the  $X$ - and  $Y$ -axes (about  $\pm 30^\circ$ ), providing fine control over the needle-insertion point and angle. The robot is compact and mountable on a standard brachytherapy stepper. One of its main advantages is the ability to manually position and orient the needle over its entire workspace when the power of the robot is off. Because the robot is not back-drivable when the power is off, the needle guide stays in position. It allows for manual control of each of the motor axes for fine positioning and has a quick-release mechanism for gross translation of the needle guide. The robot has an interface that allows the guide to be stepped through a complete treatment plan. The LDR brachytherapy seed deposition accuracy in phantom was about 1.2 mm.

### 3.B.11. RRI robot—An ultrasound image-guided prostate brachytherapy system

The Robarts Research Institute (RRI, London, Ontario, Canada) has developed a 4DOF robotic system for 3D ultrasound-guided prostate brachytherapy (Fig. 13). The system supports the needle guide from the underside by two hinged parallelograms spaced in a manner in which their fixed points of rotation are mounted onto a common shaft.<sup>23,41,94</sup> Thus, the ultrasound transducer and the robotic apparatus are remotely mounted on a common coaxial frame of reference that can be mounted onto a stabilizer.



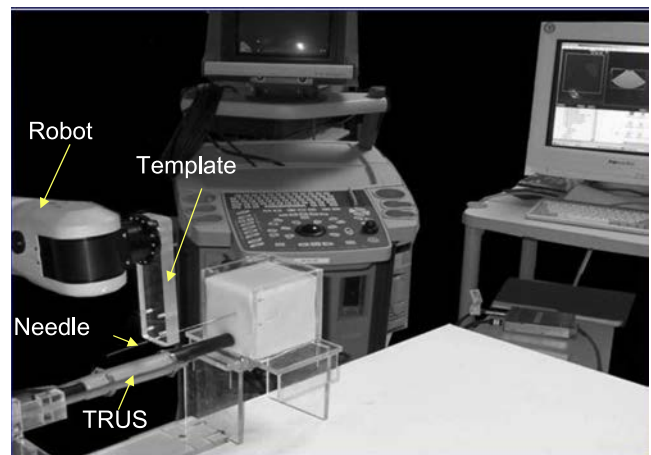
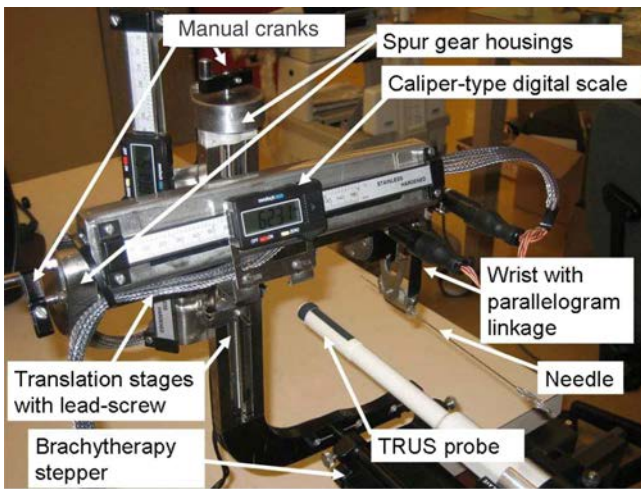

FIG. 13. RRI robot—A U/S image-guided prostate brachytherapy system.

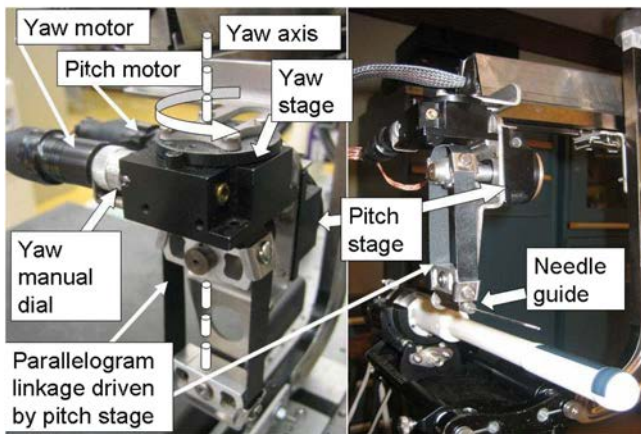

FIG. 12. UBC robot—U/S image-guided prostate brachytherapy system.

The TRUS probe equipped with a side-firing linear array is coupled to a motorized mover assembly. A 3D U/S image is generated by rotating the transducer around its long axis. After rotation by about 100°, the 3D ultrasound image is immediately available for dosimetry planning, dynamic preplanning of needle trajectories and, replanning if prostate motion is detected. The system has been designed to cover the same area as a 6 cm<sup>2</sup> template. In its current configuration, the device is capable of angulating the needle about 30°.

Tests of the system with phantoms have shown that the geometric error of the 3D ultrasound image is less than 0.4 mm. Needle-guidance accuracy tests in agar prostate phantoms showed that the mean error of seed placement was less than 1.6 mm along parallel needle paths that were within 1.2 mm of the intended target and 1° from the preplanned trajectory. At oblique angles of up to 15° relative to the probe axis, seeds were placed within 2 mm of the target with an angular error less than 2°.

**3.B.12. CHUG robot—An ultrasound image-guided prostate brachytherapy system**

The Grenoble University Hospital (CHUG, Grenoble, France) has developed a 5DOF robotic brachytherapy needle-insertion system that is designed to replace the template used

in the manual technique (Fig. 14). This robot is capable of positioning and inclining a needle within the same workspace as the manual template.<sup>95</sup> To improve needle-insertion accuracy, it incorporated provision for needle rotation during

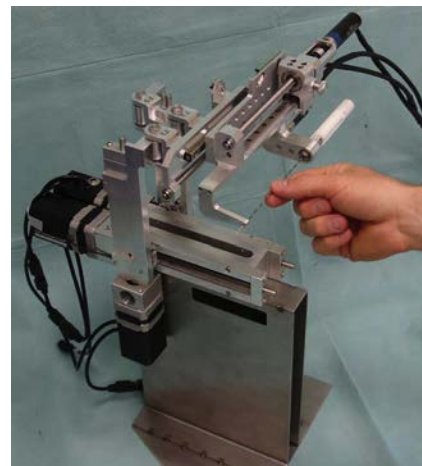

(a)

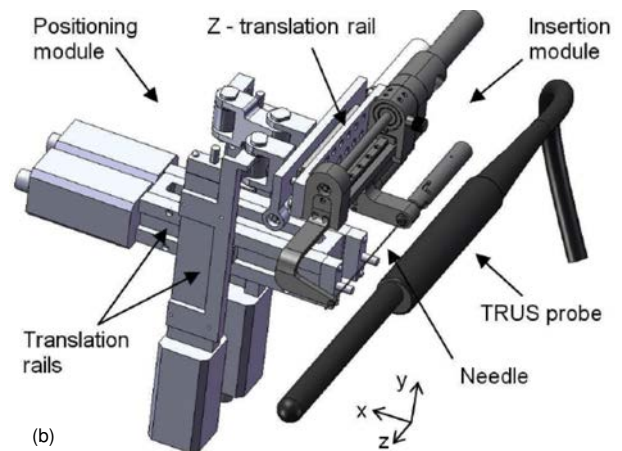

(b)

FIG. 14. TIMC-LIRMM Lab robot—U/S image-guided prostate brachytherapy system: (a) the prototype and (b) CAD model of the robotic brachytherapy needle-insertion system.



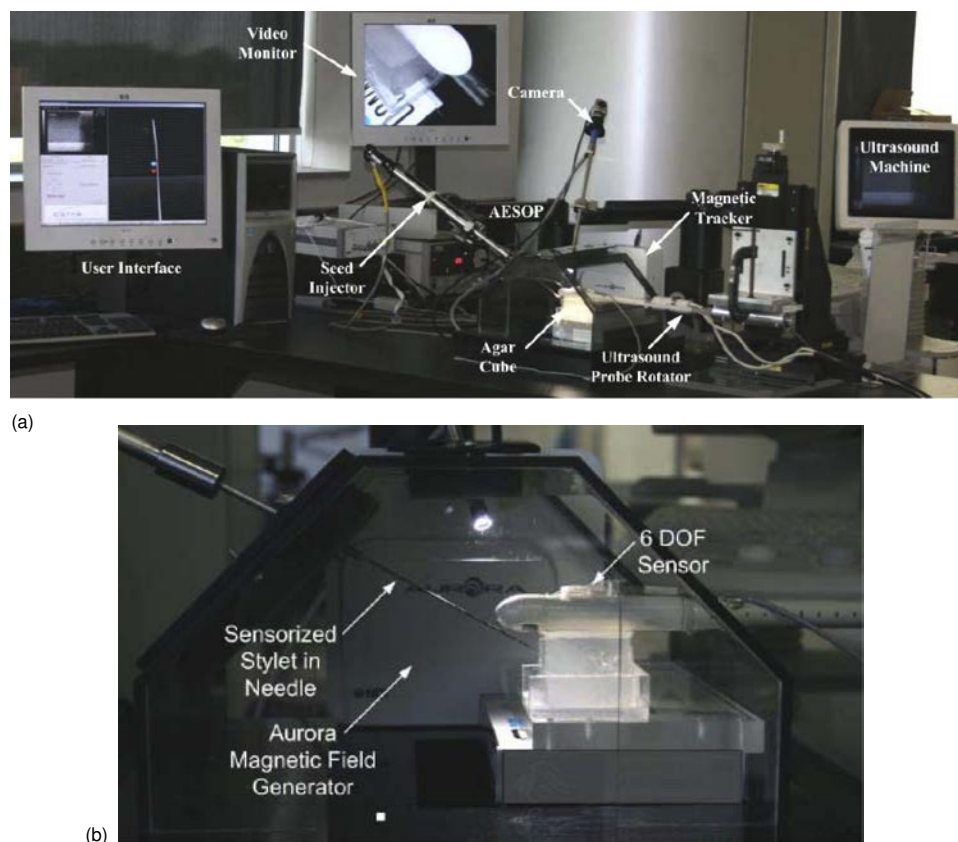

FIG. 15. The MIRA-V integrated system for lung brachytherapy: (a) view of the whole system and (b) magnetic tracker configuration.

insertion into the prostate. The system can be mounted on existing steppers and also easily accommodates existing seed dispensers, such as the Mick Applicator<sup>®</sup>. The positioning module consists of two pairs of linear translation rails mounted in the form of a parallelogramlike manipulator and allowing for translation and inclination of the insertion module. This robot is capable of inserting the needle automatically; however, LDR brachytherapy seeds can only be delivered manually. TRUS guidance makes it capable of real-time monitoring of needle insertion and seed delivery.

### 3.B.13. MIRA robot—An ultrasound image-guided lung brachytherapy system

The University of Western Ontario (UWO, London, Ontario, Canada) has developed the Minimally Invasive Robot Assistant (MIRA) for image-guided lung brachytherapy (Fig. 15). The system incorporates an experimental setup for accurate seed placement with commercially available dosimetry planning software.<sup>5,6,96–99</sup> The dosimetry planning software incorporated into MIRA-V (upgraded MIRA robot) is a modified version of previously developed software for needle guidance in prostate brachytherapy. The end result is a complete system that allows planning and executing a brachytherapy procedure with increased accuracy.<sup>5</sup> Two Automated Endoscopic Systems for Optimal Positioning (AESOP) arms are used to control the video camera and the instrument via voice control and the InterNAV3.0<sup>™</sup> interface,

respectively. These robotic arms are no longer commercially available. However, they have been chosen for the prototype evaluation and proof-of-concept as they are available for research purposes at the Canadian Surgical Technology and Advanced Robotics (CSTAR). Needle-tip position is monitored using 5DOF Aurora electromagnetic (EM) tracking sensor (NSI, Waterloo, Ontario, Canada) (Fig. 15).

## 4. ROBOTIC SYSTEM CLINICAL WORKFLOW

At this moment, it is difficult to formulate a uniform or single flowchart for a robot-assisted source implantation procedure due to the diversity in robot design and capability. Therefore, a detailed flowchart for a robotic brachytherapy procedure, which is more specific to the EUCLIDIAN, a seed implantation robotic system, is shown in Figs. 16 and 17.<sup>30</sup> The flowchart in Fig. 16 is generalized and descriptive in nature. The flowchart in Fig. 17 is very specific to EUCLIDIAN and it is exactly followed while performing clinical procedures with this robot. A near-typical workflow pattern for a robotic LDR brachytherapy seed implantation procedure is outlined below. A similar workflow could be generated for robotics in HDR applications.

### 4.A. Preliminary preparations

Sterilize the required needles. Load sterilized seeds in the sterilized cartridge. Connect TRUS probe to the ultrasound

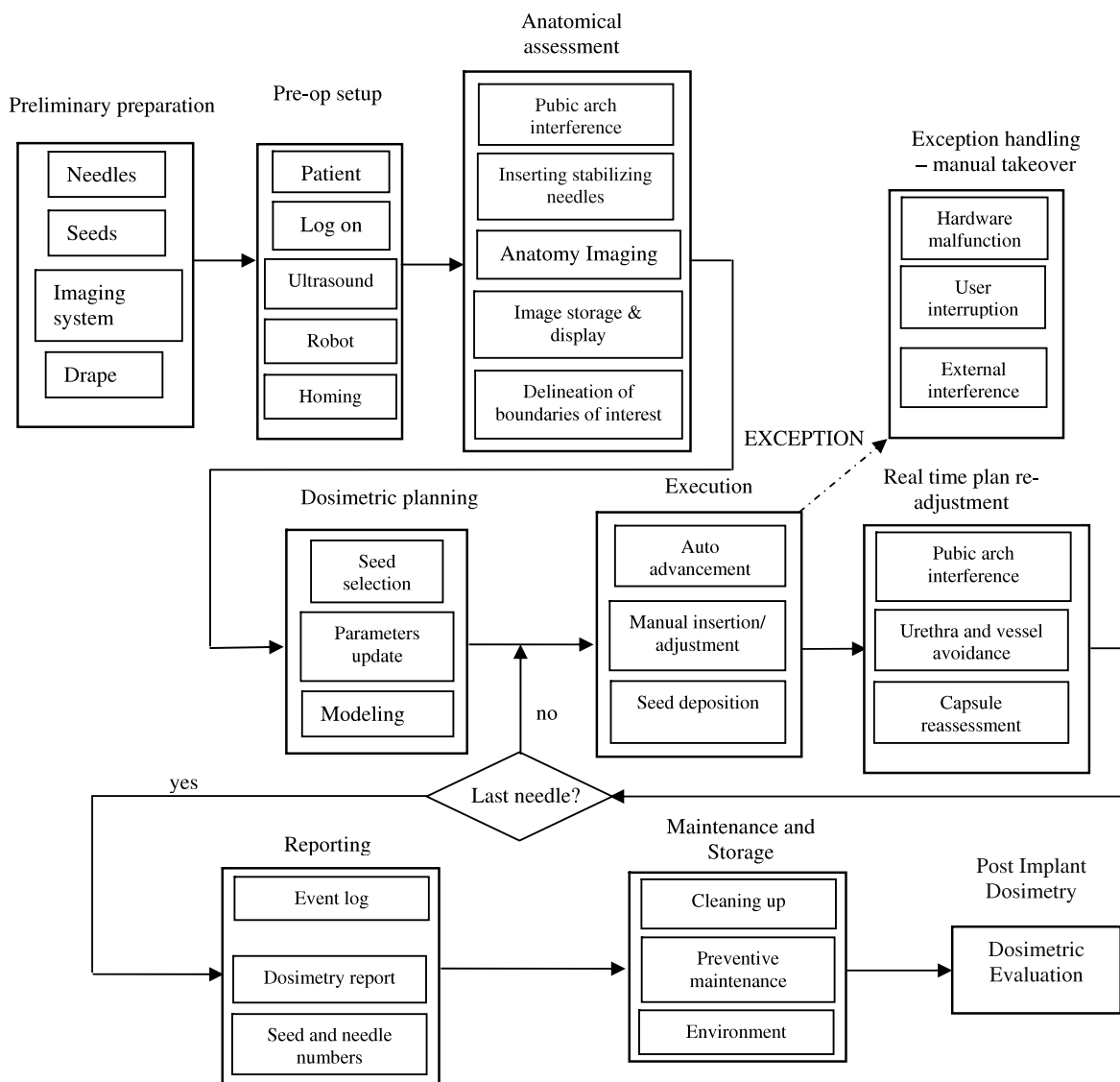

FIG. 16. Clinical workflow of a robot-assisted prostate brachytherapy.

machine. Connect the ultrasound machine to the brachytherapy computer. Cover the parts of the robot as required.

**4.B. Preoperative setup**

Clean and disinfect the robot and associated instrumentation in preparation for surgery. Initialize the robot and enter patient information into the system.

Verify adequate ultrasound image quality, accurate graphical template registration, current calibration, and home position of the robot (see Appendix C).

**4.C. Anatomic assessment**

After initial assessment of anatomical structures, insert prostate stabilizing needles according to the clinician’s preference using ultrasound imaging to appropriate location and depth.<sup>74</sup> Acquire images of the required anatomical volume. Contour the appropriate regions (prostate boundary, urethra, pubic bone, rectums, seminal vesicle, etc.) on the acquired

images. Generate 3D model/volumes of structures from these contours.

**4.D. Dosimetric planning**

Plan the coordinates of the seed distribution based on the prostate model to obtain the desired dose distribution. The TPS displays the planned isodose contours, needle positions, and seed locations in user-selected 2D and 3D orientations. This provides the clinicians a useful visualization of the whole treatment plan; if required, the clinicians can edit the plan.

**4.E. Execution**

Once the radiation oncologist approves the plan, insert needles into the patient according to the plan. If the robot is designed for TRUS and manual insertion, use a stepper and sagittal plane acquisition mode to track the needle insertion. To ensure patient safety, perform the needle insertion in a sequential order, either by the physician or by the robot. In

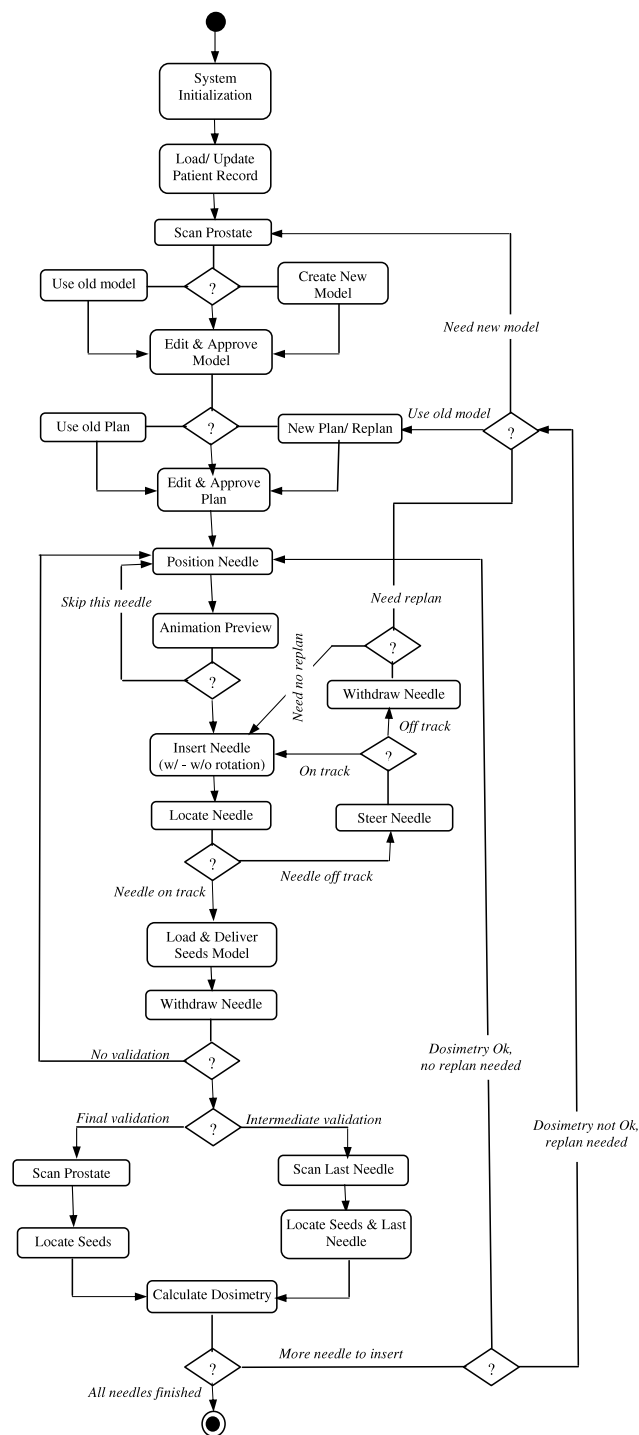

FIG. 17. Clinical workflow of EUCLIDIAN robot for prostate seed implantation.

case of a robotic insertion (e.g., EUCLIDIAN), execute the automatic positioning of the needle in front of the patient’s perineum; the robot will then ask the clinician for confirmation to proceed with the needle insertion and subsequent seed deposition. Validate (by both the physician and physicist) the seed location and dose distributions that will be produced by actual needle positions. After needle insertion, deliver the seeds according to the plan. Seed delivery can be confirmed with the help of imaging or other sensing such as seed count, source strength, and force.

In case of a semiautomatic robot (e.g., JHU robot1 and BCU robot), the needle guide is aligned in front of the patient’s perineum, the needle is inserted, and the seeds are delivered manually. Either loose seeds with Mick Applicator or stranded seeds can be used for some types of robots. However, in the current designs of the automatic robots, only loose seeds can be delivered.

**4.F. Exception handling**

Handle the radioactive seeds with care; place LDR seeds in a protective cartridge to reduce radiation exposure. If the seeds are expelled from the cartridge using a motorized stylet, precautions must be taken to not exert excessive force that may damage the seed encapsulation and allow radioactive materials to leak. To confirm that the desired seed deposition is maintained, use multiple methods, e.g., visual feedback, counting manually, or sensory feedback. Continuously monitor (visually and/or through force/positional feedback as applicable) for other potential issues such as seed jamming, undesired seed delivery, or lack of seed delivery. If for any reason the robot-assisted procedure is unable to continue, use a conventional manual technique to complete the treatment.

**4.G. Real-time plan readjustment**

If necessary and possible, adjust the needle movement or trajectory either automatically or manually by the clinician to compensate for prostate movement or deformation caused by needle insertion. Another potential solution can be to assess the tissue or target displacement and deformation in real time and adjust the dosimetric plan to obtain a new or adjusted location of the seed deposition (i.e., intraoperative reoptimization).

**4.H. Reporting**

Prepare a report as per AAPM Task Group 137 (TG-137) guidelines and/or GEC-ESTRO guidelines.<sup>100–102</sup> Generate a log file to capture the status of the robotic system during the procedure.

**4.I. Postimplant cleaning and decontamination**

Clean the robotic system and components using standard recommended clinical materials and methods, following any developer’s or manufacturer’s instructions if appropriate. Since the robotic systems used for brachytherapy are complex in terms of sterilization requirements, the physicist must identify the sterilizable components and consult the sterilization department and prepare a policy. Required sterilizable components must be sent for sterilization as deemed necessary.

**4.J. Postimplant dosimetric evaluation**

As in current practice, perform a dosimetric evaluation of the implant following the ABS recommendations, and/or the TG-137 guidelines, and/or GEC-ESTRO guidelines.<sup>100–103</sup>

## 5. ROBOTIC SYSTEM SAFETY

Safety of the patient and the clinical staff is the most critical criteria of any clinical procedure. The clinicians and robot must work together in a synergistic way due to the complexity and constraints of the clinical environment. Since the robot is moving in close proximity to the patient and staff, all movements must be verified to avoid physical injury as well as collision with the procedure environment. These requirements are more critical for advanced robots that carry needles and radioactive seeds. Some of the potential safety issues include

- undesired movement of the robot (or the patient) that may cause physical injury to the patient or the staff, or damage to instrumentation,
- erroneous needle or seed placement,
- needle bending or breaking,
- incorrect number of seeds delivered,
- production of unacceptable radiation exposure, and
- delay in the procedure.

It is desirable that excessive movement of the patient be monitored. The robot should have provisions for responding to these situations to ensure clinical safety. All these issues should be considered during the design, implementation, and operation of any robotic system for brachytherapy source implantation.

Safety issues of MRI-guided robotics also involve the use of MR compatible materials and RF safety. Ferromagnetic structures may become dangerous projectiles in the magnetic field near the MR scanner.<sup>104–107</sup> In addition, ferromagnetic structures greatly distort the field uniformity inside the magnet, which results in image quality degradation. All robotic components should therefore be tested for ferromagnetism. The use of nonferromagnetic metals such as brass, copper, titanium, and aluminum is allowed, although they also can perturb magnetic field homogeneity and distort images.<sup>81</sup>

Another safety issue is the risk of RF-induced heating when using specific materials, e.g., a titanium needle. Although often regarded as MRI compatible, a conductive titanium needle can act as a dipole antenna that interacts with the electromagnetic RF field applied to generate an MR image. The altered electric field is strongly increased at the tip of the needle resulting in increased tissue heating in this region.<sup>108</sup> The amount of heat deposition depends on many factors, such as resonance and other electrical properties and volume of the surrounding medium, the needle position within the MR bore, the needle-insertion depth, and the RF power of the MR imaging sequence.<sup>109–114</sup> Due to these multiple factors, the amount of tissue heating is hard to predict. The risk of thermal injury is small for interventions at 1.5 T with a titanium needle and insertion depth smaller than 15 cm from the scanner center. The risk of tissue heating is higher for interventions at higher magnetic field strength. The risk can be reduced by the use of needle coating or excluded by using nonconductive needle materials.<sup>109</sup> In theory, the RF waves can also induce currents in conductive robotic components resulting in heating in the surrounding tissue. Therefore,

patient contact with electromagnetically conductive robotic components should be avoided.

## 6. COMMISSIONING

Each of the existent robotic brachytherapy systems is unique and different to the point that prevents prescriptive guidelines for specific quality management procedures. Any user should carefully consider the potential challenges to quality and the risks of the system they use following the methodology described in the planned report of the Task Group 100, which is expected to focus on risk assessment in radiation therapy.<sup>115</sup> Only aspects pertinent to the robotic features of robot-assisted brachytherapy are discussed herein.

Achieving the quality desired in the treatment requires at a minimum those items referred to in the Task Group 100 report as the key core requirements:

1. Training—Before beginning a new treatment modality, make sure that each team member has received training in the procedures and operations with demonstrated expertise.
2. Communications—Communication patterns must be established clearly and formally so that each team member understands the information necessary to exchange and the mechanisms for passing the information. Forms and checklists provide inexpensive and yet effective tools for guiding and facilitating communication.
3. Standardized protocols and procedures—Standard procedures reduce the likelihood of errors and help maintain tight control of quality. Exceptions to the standard procedures, of course, must be allowed, but they should be the rare exception.
4. Adequate resources—Any procedure needs adequate staffing and materials to succeed and not providing the resources greatly increases the probability of failure.

Commissioning forms the foundation for quality management. Commissioning includes evaluation and initiation of the equipment and of the procedures.

### 6.A. Commissioning of robotic equipment

The prior step to commissioning equipment is acceptance testing, simply evaluating that the equipment as delivered performs as specified by the manufacturer. Acceptance testing tends to be narrow, including only the terms of purchase agreed upon between the vendor and the buyer. While important, acceptance testing seldom provides sufficient information about equipment function for clinical use. Also, since many of the brachytherapy robots currently in use are not commercial (except Elekta's FIRST, i.e., Oncentra Integrated Prostate Solution system), there likely would be no purchase specification against which to evaluate the system. The clinically relevant testing comes in the next step of commissioning the robotic system.



Clinical commissioning of the brachytherapy robot entails establishing how well the robot works under various conditions and in what situations it might fail. It also includes gathering information necessary for its operation. During clinical commissioning, tests should be conducted to ensure that this level of accuracy is maintained. These tests should mimic the real operating procedure as closely as possible. Commissioning not only needs to establish that the equipment operates as intended but also finds the limits of reliable operation and in which situations the equipment fails. The following items must be evaluated during commissioning of the robotic system, creating baseline data to be used for future quality management.

1. A spatial accuracy of 1.0 mm (SD =  $\pm 0.5$ ) for seed placement in a soft material phantom is achievable by robotic brachytherapy systems. Considering that manual LDR seed placement has an estimated accuracy of 3–6 mm and seeds are known to move in a patient due to edema resolution or other reasons, robotic systems must have a spatial accuracy of seed placement in a phantom that is  $\leq 1.0 \pm 0.5$  mm (range 0–2 mm).<sup>116–118</sup>
2. Linear travel precision and accuracy of the needle tip in air should be within the reported mechanical specifications from the manufacturer. This should be verified over the full useful range of the system. The measured position of the needle tip should be relative to the image-based reference origin which is attached to the image stack or imaging system.
3. Linear travel precision and accuracy of the needle tip in an implantable, soft tissue-equivalent (considering mechanical properties and image quality) phantom should be within the manufacturer specifications. These would be tested the same way as the tests mentioned in item 2.
4. Linear travel precision and accuracy of the needle tip in a water phantom with respect to a reference image should be within the manufacturer specifications.
5. Rotational travel precision and accuracy must operate within manufacturer specifications. If the system performs rotation, inclination, declination, pitch, yaw, etc., the mechanical precision and accuracy should be verified for each DOF. A digital level, inclinometer, or equivalent instrument should be used to quantify angles. Some needle angulations (e.g., angulating up–down in sagittal plane) are known to be associated with magnification of any error. For example, when a needle is angulated about an axis at the base, a small error in angular position will be amplified in tip position. The medical physicist should be aware of such effect and relate these angular inaccuracies to the final endpoint of seed position in the target volume.
6. Combination of rotations and linear motions must not degrade the precision and accuracy of needle-tip placement. Different combinations that are meant to give the same location must do so within the system specification. Seed delivery precision and accuracy

must remain within the manufacturer specification regardless of needle orientation or movement pattern.

7. Mechanical-to-imaging space can be coregistered. If the system is factory-calibrated, verify accuracy over the full range of conventional template grids. If user calibration is required, verify that the adjustable range covers all possible setup conditions. Depending on imaging modality, appropriate medium and phantom should be used. For TRUS imaging, the guidance of AAPM TG-128 should be followed and effects of probe covering material should be considered.<sup>119,120</sup> It must be demonstrated that the needle tip can be positioned over the full range of conventional template grids within the manufacturer specified precision in water or air.
8. Image acquisition and reconstruction must ensure spatial and volumetric accuracy consistent with the imaging modality. For the given imaging modality, appropriate phantom tests should be carried out to ensure that known geometric shapes and volumes can be accurately reconstructed by the TPS. For TRUS imaging, tests as described in the AAPM TG-128 report should be performed and compared with the accuracy specified for the particular robotic system. Other imaging modalities require a similar set of evaluations that could use TG-128 as a guide.<sup>119</sup>
9. A TPS system should be used that is compatible with the robotic system in use and should, for example, optimize the positions for sources and needle paths. The optimization program should determine the desired location of sources in the absence of a template (unless one is used) as well as determine the desired trajectories of the needles, which may include minimizing the number of needles or insertions into the patient, as well as establishing needle paths that avoid obstructions.<sup>70</sup> Validation of this feature proves challenging at the time of the writing of this report, though work is underway. For example, Cunha *et al.* present a method for optimizing HDR <sup>192</sup>Ir brachytherapy needle patterns using robot-enabled geometries that avoid structures of the penis.<sup>28</sup>
10. Travel limits of the robotic system must ensure patient and operator safety and prevent collisions with imaging equipment and the OR environment. Needle insertion must have operator definable mechanical or electronic limits for distal travel. Any moving articulator must be confined to operator definable workspaces. After travel limits of the needle are set, the needle cannot be advanced beyond the set limits except through physician override or a limit reset.
11. Proper function of those robot parts that assess insertion resistance and inhibit needle insertion when encountering situations, e.g., pubic arch interference, requiring abnormally high force must be verified. For example, forces exceeding 20 N for 18-gauge needle and 25 N for 17-gauge needle to move the needle forward are considered excessive and should trigger automatic motion cessation.<sup>17</sup>

12. The system must be able to recover and continue normally from power interruption and system crash. Tests should be performed after (a) system setup, (b) image acquisition, (c) treatment plan approval, and (d) selected needle insertion and/or seed deposition. The system must not lose absolute or relative position information after setup, or mechanical-to-imaging space registration. Approved image sets and treatment plans should be recoverable. If seed deposition has occurred, the system must be able to continue at the next seed position in the plan.
13. Any tracking system used with the device should follow similar commissioning and QA practices as are commonly utilized for external-beam radiation tracking devices.<sup>121</sup>
14. Electrical safety, including leakage current, noise, and stability must comply with accepted standards; e.g., IEC 60601 guidelines must be followed.
15. Each brachytherapy robot design may offer unique features that will require appropriate testing. Other general features of the robot not specifically listed here require evaluation that those features function as designed.

### 6.B. Commissioning of the clinical procedure

Just as equipment requires commissioning, so do the clinical procedures. Commissioning of a clinical procedure entails the following:

1. Gather the information that will be needed during the clinical procedure and organize it in a readily accessible location.
2. Compose the forms and checklists that will be used.
3. Assemble the clinical personnel and walk through the clinical procedure as closely as possible as it will be performed with a patient. Having a tissue-equivalent imageable and implantable phantom helps simulate the brachytherapy procedure. During this simulation, particular attention should be paid to communication, operation of the equipment, and clarity of roles.

Following the clinical procedure simulation, the team should critique the procedures and make appropriate revisions following the plan-check-act mantra.

## 7. QUALITY MANAGEMENT

Users of new technologies have the responsibility to develop a suitable quality management program (QMP). Even after professional societies issue guidelines for users on developing a QMP for new technologies, users are responsible for customizing this for their specific circumstances. At the time of writing and for the foreseeable future, no information exists on the frequency and nature of failures for any of the robots in use, except the preclinical study data from the EUCLIDIAN robot and an example of daily QA procedure mentioned in Appendix C.<sup>30</sup> Consequently, it is not yet possible

to assign priorities to specific QA tasks based on data or observations. All of the features mentioned in the commissioning of equipment section (Sec. 6) must be ensured for reliable use at all times and for all cases. Validation of operation does not require a complete commissioning for each patient case because initial commissioning and ongoing QA verify correct operation within and outside the intended operation limits. Quality management requires thoughtful sampling over the operational range to test the system. The scope of tests depends on the specific system and the types of cases to be performed. All tasks associated with the clinical procedure should be incorporated into the QMP. This would include tasks prior to daily use such as system calibration and tasks performed during the clinical procedure such as ensuring correct seed positioning in the particular patient. For this latter task, image-guidance provides a considerable amount of feedback for verifying seed positioning during the procedure.

## 8. RECOMMENDATIONS

1. In the current generation of brachytherapy robots, three main types of interactions have been implemented: (1) semiautonomous robots execute tasks under human supervision, (2) partially semiautonomous robots position a needle guide which is used by the clinician to insert a needle and manually deliver the seed, and (3) robots build and insert a seed train after a radiation oncologist inserts a needle. Robots that are capable of operating in both semiautonomous and partially semiautonomous modes must be able to display their current operational mode, with an emergency reset to default to either semiautonomous or resting mode.
2. Clinicians should have the capability to control the robot at any desired time as well as the provisions for approval at various critical or important steps, i.e., the robot software should require confirmation from the clinician before performing any important step automatically. All robots under the Classes of 1–3 (see Sec. 2) follow the above-mentioned methodology. However, discussion of Class 4 robots, which are fully autonomous, is beyond the scope of this report.
3. The robotic system should have the capability (manual or automatic) of correcting for needle deviation, and compensating for organ deflection, tissue deformation, and needle deviation so that the needle can reach the desired target location with required accuracy.
4. At all stages where data entry and dose calculation are required, there should be documented policies and procedures for independent check and data verification by the user before robotic execution begins.
5. The TPS should provide the clinicians an intuitive guidance interface displaying the robotic implantation plan with visualization of needle positions and seed locations relative to the target anatomy.
6. Patient safety data are lacking at this time regarding robotic insertion of multiple needles simultaneously.

It is recommended that needle insertion be performed in a sequential order by the robot as in current brachytherapy practice. However, research on the simultaneous insertion of multiple needles is ongoing and it may be found efficacious and preferable.

7. Both robot–clinician and robot–patient interactions should be designed to ensure robustness, reliability, and safety while delivering the correct dose at the correct site for the correct patient. If the clinician, patient, or robot detects a violation of these priorities, the robot should be able to return immediately to a default resting state that provides minimal risk of damage and minimal risk to the patient or caregivers. It is to be remembered that the general SAUR principle should be followed.
8. Care must be taken to avoid exerting excessive force on radioactive sources and damaging capsule integrity, especially when implantation is carried out using a motorized stylet.
9. Delivery confirmation of the required number of seeds must be maintained through one or multiple methods such as visual feedback, counting manually, or sensory feedback. Personnel should be vigilant in detecting issues such as seed jamming or spurious delivery (or nondelivery) of seed. There should be sufficient shielding provisions to reduce personnel radiation exposure around the robot.
10. Since the robot is moving in close proximity to the patient and the staff, all movements must be verified or checked to avoid potential physical injury as well as collision with the OR environment. This is more critical for advanced robots, which carry needles and radioactive sources as well as provide automatic delivery. Some potential safety issues are undesired movement of the robot that may cause physical injury and trauma to the patient or personnel, damage to the OR equipment, erroneous needle placement and seed delivery, and needle bending or breakage. These issues should be considered during design, implementation, and operation of any robotic brachytherapy system for seed implantation.
11. Cleaning and decontamination are necessary for any surgical device. For an IGBT robot, cleaning and decontamination must be performed in a manner similar to the standard OR procedures while observing the electromechanical safety and functionality of the system. A standardized cleaning, decontamination, and sterilization cycle of reusable surgical instrument should be developed in collaboration with infection control experts.

## 9. CONCLUSIONS AND FUTURE PERSPECTIVES

In this report, advantages of robotic assistance in brachytherapy procedures have been projected. These advantages include higher precision and accuracy of seed placement than possible when performed manually, improvements

in the calculation of optimal seed positions, minimization of surgical trauma, and reduction of radiation exposure to medical staff. So far, 13 robotic systems have been developed for brachytherapy. However, they differ from each other with respect to the available features, functionalities and levels of automation. Except one system (Oncentra Integrated Prostate Solution for Seeds), all other systems are developed at universities and hospitals and have not yet been commercialized. The majority of systems have not yet been used clinically. Due to the wide variability among the available robotic systems, various sections such as safety, commissioning, and recommendations have been written focusing on brachytherapy procedures rather than any specific robotic system. Application of robotic systems in brachytherapy is a developing field and it is premature to make strict recommendations at this time. We expect that with time and by using this report, robotic systems will become standardized for brachytherapy procedures and some of the systems will be commercially available. Consequently, we expect that an update to this Task Group report is inevitable.

## APPENDIX A: DEFINITIONS AND NOMENCLATURES

Actuator	= a mechanical device for moving or controlling a mechanism or system
Back-drivable joints	= when the motor power is off, the robot arm/joint can be moved with external force. This offers flexibility in robotic operation
DOF	= degree of freedom
Haptic force	= the process of sensing force through touch
HDR	= high-dose-rate
Joint	= connection of two links of a robot
LDR	= low-dose-rate
Manipulator	= mechanical arm/linkage of the robot
OR	= operating room
PID controller	= proportional, integral, and derivative control is a commonly used controller that reduces error asymptotically
PSI	= prostate seed implantation
QA	= quality assurance
QMP	= quality management program
Robot	= a reprogrammable multifunctional manipulator designed to move materials, parts, tools, or specialized devices through variable programmed motions for performance of a variety of tasks
Robot path planning	= the process of generating a path in 3D space to accomplish a specific task
Robot workspace	= a 3D volume within which the robot can execute dynamic motion without collision or interaction with the surrounding environment
SAUR	= safety, accuracy, user-friendliness, and reliability
SD	= standard deviation

- TPS = treatment planning system
- TRUS = transrectal ultrasound
- Work space = the 2D space on the patient surface that the robot’s end-effector or tip can reach without losing any degree of freedom

**APPENDIX B: TEST PROTOCOL**

**1. Test procedures for evaluating performance of brachytherapy robots**

**a. Purpose**

During formulation of guidelines for this Task Group report on robotic brachytherapy, it was felt that a uniform test protocol should be followed for evaluating the performance of any robotic system that would be used for brachytherapy, especially for seed implantation. The parameters that need to be evaluated are as follows:

- (1) Positional accuracy of needle tip
- (2) Repeatability of needle-tip position
- (3) Positional accuracy of the delivered seeds
- (4) Robot-to-imager calibration accuracy
- (5) Qualitative assessment of tissue damage (if needle rotation provision is used)

**b. Materials**

1. Robot in desired working condition
2. Needles (stylet and canulla; about 20)
3. Graph papers, a slab of styrofoam (for in-air measurements)
4. Soft material phantom
5. Dummy (or decayed) seeds (about 80–100) and seed cartridges; for these experiments, round-end stainless steel dummy/decayed seeds will be used
6. Mick Applicator (for semiautonomous robotic system)
7. Position measurements—CT (also with fluoroscopy/x-ray if available/suitable)

**c. Methods**

There are approaches for preparing phantoms. Recent work presented by Hungr *et al.* outline a method for preparation of polyvinylchloride (PVC)-based phantoms.<sup>122</sup> For maintaining the consistency of the phantoms, one of the institutes (TJU or CWRU) will prepare and ship the phantoms made from liquid plastic and softener (MF Manufacturing Co., Fort Worth, TX) in the ratio 80%–20%, respectively, to the other institutes for experimentation.

- (1) Arrange all the above-mentioned materials and equipment prior to the experiment.
- (2) For in-air measurement, paste/attach the graph paper on the styrofoam slab; secure the position of the styrofoam slab (with the graph paper) vertically, i.e., perpendicular to the direction of the needle advancement at 3 cm from the distal support of the needle holder.

Make sure that a fixed reference coordinate frame is identified for absolute measurements. Move the robot/needle holder in  $4 \times 4$  locations ( $x$ - $y$  plane, i.e., perpendicular to the depth) at  $2 \times 2$  cm grid and in a zigzag pattern (as shown in Fig. 18 below). Insert needle tip at each location for 100 times (only insert the tip, do not advance the needle too much for avoiding the circular pattern of the indentation). Take picture of the needle-insertion graph paper with a high-resolution digital camera for further analysis of repeatability and accuracy of needle position. Use encoder and/or vernier calipers for  $z$ -direction (depth) measurements.

- (3) Secure the phantom (phantom in a Plexiglas box) at a known coordinate with respect to a fixed reference frame (preferably the same one used for dosimetric planning or may be the common reference frame on a fixed location on the robot).
- (4) Needle-insertion speed
  - 2, 5, and 7 cm/s (for autonomous robots)
  - with normal clinical speed (for semiautonomous robots).<sup>17</sup>
- (5) Insert  $4 \times 4 = 16$  needles at  $1 \times 1$  cm grid up to a depth of 10 cm in the phantom. Follow the insertion pattern shown in Fig. 18.
- (6) Use free/loose seeds in a cartridge for depositing 5 seeds per needle at 2 cm spacing (center to center distance between two consecutive seeds).
- (7) Take direct measurements of the projected seed positions from the fixed reference frame as well as relative measurements between seeds. Take pictures with a digital camera at different planes; take fluoroscopic images in orthogonal planes (if available). Take CT images in transverse plane as well as in sagittal plane (submillimeter slice thickness is desirable).

**d. Data analysis**

- (1) Transfer digital images into a computer and analyze the needle-insertion marks and/or seed potions by magnifying the image suitably (five times or so).
- (2) Fluoroscopic images are to be scanned and loaded into the computer for analysis of seed deposition accuracy in  $x$ -,  $y$ -, and  $z$ -directions. The CT images in both the transverse and sagittal planes are to be analyzed for 3D accuracy of seed deposition.
- (3) Report all measurement results in tabular form as shown below (Table II).

1	14	7	3
10	12	15	5
6	16	9	13
4	8	11	2

FIG. 18. Needle movement/insertion pattern.



**e. Results**

TABLE II. Experimental results for test procedures to evaluate the performance of brachytherapy robots.

		Average	SD	Range	r.m.s.	Remark
Error in needle-tip position	<i>x</i> -direction					
	<i>y</i> -direction					
	<i>z</i> -direction					
	Angulation error (if any)					
Repeatability of needle-tip position	<i>x</i> -direction					
	<i>y</i> -direction					
	<i>z</i> -direction					
	Angulation (if any)					
Error in seed delivery position	<i>x</i> -direction					
	<i>y</i> -direction					
	<i>z</i> -direction					

**APPENDIX C: EXAMPLE OF QA PROCEDURE**

Daily quality assurance of EUCLIDIAN — Image-guided robotic system for prostate brachytherapy							
<b>I. Mechanical screening test</b>							
<b>1 Visual check</b>	Connectors	Controllers	Wires	Sensors	Motors	Overall	
Outcome							
<b>2 Connectivity</b>	Controllers	Motors	Encoders	Moving parts			
Outcome							
<b>3 Sensors</b>	Readings	Sensitivity					
Outcome							
<b>4 Needling mechanic</b>	Cannula installation	Stylet installation	Sterilizing parts				
Outcome							
<b>5 Other</b>	Emergency button	Translation knob	Rotation knob				
Outcome							
<b>II. Robot functionality test</b>							
<b>1 Hardware detection</b>	Controllers	Frame grabber	Sensors	Emergency buttons			
Outcome							
<b>2 Mobility</b>	Probe stage	Needling mechanism	XVZ platform motion				
Outcome							
<b>3 Case test</b>	Import images	Quick plan					
Outcome							
<b>III. Imaging module test</b>							
<b>1 Image calibration</b>	Grid matching test						
	Difference	Yes/no					
<b>2 Precision</b>	Accuracy	X	Y	Z			
	Measure 1 - point 1						
	Measure 1 - point 2						
	Measure 2 - point 1						
	Measure 2 - point 2						
Physicist					Date		
Physicist					Date		

- <sup>a)</sup>Author to whom correspondence should be addressed. Electronic mail: tarun.podder@uhhospitals.org
- <sup>1</sup>R. Nath, L. L. Anderson, J. A. Meli, A. J. Olch, J. A. Stitt, and J. F. Williamson, "Code of practice for brachytherapy physics: Report of the AAPM Radiation Therapy Committee Task Group No. 56," *Med. Phys.* **24**, 1557–1598 (1997).
  - <sup>2</sup>U. K. Henschke, "Afterloading applicator for radiation therapy of carcinoma of the uterus," *Radiology* **74**, 834 (1960).
  - <sup>3</sup>U. K. Henschke, B. S. Hilaris, and D. G. Mahan, "Remote afterloading with intracavitary applicators," *Radiology* **83**, 344–345 (1964).
  - <sup>4</sup>P. P. Kumar, U. K. Henschke, and D. G. Mahan, "Remote afterloading for intracavitary radiation therapy," *Prog. Clin. Cancer* **10**, 127–136 (1965).
  - <sup>5</sup>W. Lin *et al.*, "Electromagnetic navigation improves minimally invasive robot-assisted lung brachytherapy," *Comput. Aided Surg.* **13**, 114–123 (2008).
  - <sup>6</sup>S. Mohan *et al.*, "Computer integrated system for minimally invasive lung brachytherapy," *Stud. Health Technol. Inform.* **132**, 296–301 (2008).
  - <sup>7</sup>J. Rieke *et al.*, "CT-guided brachytherapy. A novel percutaneous technique for interstitial ablation of liver metastases," *Strahlenther. Onkol.* **180**, 274–280 (2004).
  - <sup>8</sup>L. Maier-Hein *et al.*, "Human vs robot operator error in a needle-based navigation system for percutaneous liver interventions," *Proc. SPIE* **7261**, 72610Y (2009).
  - <sup>9</sup>K. S. Fu, R. C. Gonzalez, and C. S. G. Lee, *Robotics: Control, Sensing, Vision, and Intelligence* (McGraw-Hill, New York, NY, 1987).
  - <sup>10</sup>T. B. Sheridan, *Telerobotics, Automation, and Human Supervisory Control* (MIT, Cambridge, MA, 1992).
  - <sup>11</sup>S. D. Chang and J. R. Adler, "Robotics and radiosurgery—The CyberKnife," *Stereotact. Funct. Neurosurg.* **76**, 204–208 (2001).
  - <sup>12</sup>M. Quinn, "CyberKnife: A robotic radiosurgery system," *Clin. J. Oncol. Nurs.* **6**, 149 (2002).
  - <sup>13</sup>S. R. Dev and S. Dev, "Robotics: History, present status and future trends," in *Robotics Technology and Flexible Automations* (Tata McGraw Hill, New Delhi, 2010), ISBN (13): 978-0-07-007791-1.
  - <sup>14</sup>Y. Yu *et al.*, "Robotic system for prostate brachytherapy," *Comput. Aided Surg.* **12**, 366–370 (2007).
  - <sup>15</sup>M. P. van Gellekom, M. A. Moerland, H. K. Wijdeman, and J. J. Battermann, "Quality of permanent prostate implants using automated delivery with seedSelectron versus manual insertion of RAPID strands," *Radiother. Oncol.* **73**, 49–56 (2004).
  - <sup>16</sup>M. R. van den Bosch *et al.*, "Feasibility of adequate dose coverage in permanent prostate brachytherapy using divergent needle insertion methods," *Radiother. Oncol.* **86**, 120–125 (2008).
  - <sup>17</sup>T. K. Podder *et al.*, "In vivo motion and force measurement of surgical needle intervention during prostate brachytherapy," *Med. Phys.* **33**, 2915–2922 (2006).
  - <sup>18</sup>T. K. Podder *et al.*, "Surgical needle intervention in soft tissue: In-vivo force measurement," in *Proceedings of the International Conference of the IEEE Engineering in Medicine and Biology Society (EMBS/EMBC), New York, NY* (IEEE, New York, NY, 2006), pp. 3652–3655.
  - <sup>19</sup>T. K. Podder *et al.*, "Mechanical properties of human prostate tissue in the context of surgical needle insertion," *Int. J. Comput. Assist. Radiol. Surg.* **2**, S106–S108 (2007).
  - <sup>20</sup>J. Shigley, C. Mischke, and R. Budynas, *Mechanical Engineering Design*, 7th ed. (McGraw-Hill, New York, NY, 2003).
  - <sup>21</sup>J. Shigley, C. Mischke, and R. Budynas, *Standard Handbook of Machine Design*, 3rd ed. (McGraw-Hill, New York, NY, 2004).
  - <sup>22</sup>T. K. Podder *et al.*, "Effects of velocity modulation during surgical needle insertion," in *Proceedings of the Annual International Conference of the IEEE Engineering in Medicine and Biology Society* (IEEE, New York, NY, 2005) Vol. 6, pp. 5766–5770.
  - <sup>23</sup>G. Wan *et al.*, "Brachytherapy needle deflection evaluation and correction," *Med. Phys.* **32**, 902–909 (2005).
  - <sup>24</sup>M. A. Meltner *et al.*, "Observations on rotating needle insertions using a brachytherapy robot," *Phys. Med. Biol.* **52**(19), 6027–6037 (2007).
  - <sup>25</sup>D. S. Stember and J. P. Mulhall, "The concept of erectile function preservation (penile rehabilitation) in the patient after brachytherapy for prostate cancer," *Brachytherapy* **11**, 87–96 (2012).
  - <sup>26</sup>N. Fleming *et al.*, "Ultrasound elastography - enabling technology for image guided laparoscopic prostatectomy," *Proc. SPIE* **7261**, 72612I (2009).
  - <sup>27</sup>L. L. Yeung and L. M. Su, "Technologies for imaging the neurovascular bundle during prostatectomy," in *New Techniques in Urology*, edited by P. Dasgupta, J. M. Fitzpatrick, R. Kirby, and I. S. Gill (Springer-Verlag, London, 2010).
  - <sup>28</sup>J. A. M. Cunha *et al.*, "Robot-guided delivery of brachytherapy needles along non-parallel paths to avoid penile bulb puncture," *Brachytherapy* **11**, 348–353 (2012).
  - <sup>29</sup>Y. D. Zhang *et al.*, "Design and experiments of seed delivery device for prostate brachytherapy," in *IEEE International Conference on Intelligent Robots and Systems (IROS), Beijing, China* (IEEE, New York, NY, 2006), pp. 1280–1284.
  - <sup>30</sup>T. K. Podder, I. Buzurovic, K. Huang, T. Showalter, A. P. Dicker, and Y. Yu, "Reliability of EUCLIDIAN: An autonomous robotic system for image-guided prostate brachytherapy," *Med. Phys.* **38**, 96–106 (2010).
  - <sup>31</sup>IEC 60601-1:2005, *Medical Electrical Equipment—Part 1: General Requirements for Basic Safety and Essential Performance* (International Electrotechnical Commission, Brussels, 2005).
  - <sup>32</sup>R. Nath *et al.*, "Recommendations by the AAPM and GEC-ESTRO on the use of new or innovative brachytherapy sources, devices, applicators, or applications: Report of Task Group 167" (unpublished).
  - <sup>33</sup>H. F. Hope-Stone, S. C. Klevenhagen, B. S. Mantell, W. Y. Morgan, and S. A. Scholnick, "Use of the curietron at The London Hospital," *Clin. Radiol.* **32**, 17–23 (1981).
  - <sup>34</sup>P. R. Almond, "Remote afterloading," in *AAPM Monograph No. 9, Advances in Radiation Therapy Treatment Planning*, edited by A. E. Wright and A. L. Boyer (American Institute of Physics, New York, NY, 1983), pp. 601–619.
  - <sup>35</sup>G. P. Glasgow, J. D. Bourland, P. W. Grigsby, J. A. Meli, and K. A. Weaver, *AAPM Task Group No. 41: A Report on Remote Afterloading Technology* (American Institute of Physics, New York, NY, 1993).
  - <sup>36</sup>M. Bidmead *et al.*, "A practical guide to quality control of brachytherapy equipment," in *ESTRO Booklet No. 8*, edited by J. Venselaar and P. Calatayud (ESTRO, 1200 Brussels, Belgium, 2004).
  - <sup>37</sup>D. M. Elliott *et al.*, "Automated implantation system for radioisotope seeds," U.S. patent 6869390 B2 (22 March 2005).
  - <sup>38</sup>G. Fichtinger *et al.*, "System for robotically assisted prostate biopsy and therapy with intraoperative CT guidance," *Acad. Radiol.* **9**, 60–74 (2002).
  - <sup>39</sup>G. Fichtinger *et al.*, "Robotic assistance for ultrasound guided prostate brachytherapy," *Med. Image Comput. Comput. Assist. Interv.* **10**, 119–127 (2007).
  - <sup>40</sup>D. Y. Song *et al.*, "Robotic needle guide for prostate brachytherapy: Clinical testing of feasibility and performance," *Brachytherapy* **10**, 57–63 (2011).
  - <sup>41</sup>Z. Wei *et al.*, "Robot-assisted 3D-TRUS guided prostate brachytherapy: System integration and validation," *Med. Phys.* **31**, 539–548 (2004).
  - <sup>42</sup>N. Bluval *et al.*, "A needle guidance system for biopsy and therapy using two-dimensional ultrasound," *Med. Phys.* **35**, 617–628 (2008).
  - <sup>43</sup>B. L. Davies *et al.*, "Brachytherapy—An example of a urological minimally invasive robotic procedure," *Int. J. Med. Robot. Comput. Assist. Surg.* **1**, 88–96 (2004).
  - <sup>44</sup>M. Meltner, N. Ferrier, and B. Thomadsen, "Design and quantitative analysis of a novel brachytherapy robot," *Med. Phys.* **32**, 1949 (2005).
  - <sup>45</sup>M. A. Meltner, "Design and optimization of a brachytherapy robot," Ph.D. thesis, Department of Medical Physics, University of Wisconsin–Madison, 2007.
  - <sup>46</sup>Y. Yu *et al.*, "Robot-assisted prostate brachytherapy," *Med. Image Comput. Comput. Assist. Interv.* **9**, 41–49 (2006).
  - <sup>47</sup>H. Bassan, R. V. Patel, and M. Moallem, "A novel manipulator for prostate brachytherapy: Design and preliminary results," in *Proceedings of the IFAC Symposium on Mechatronic Systems, Heidelberg, Germany* (Elsevier, Frankfurt, D60486, 2006), pp. 30–35.
  - <sup>48</sup>H. Bassan, T. Hayes, R. V. Patel, and M. Moallem, "A novel manipulator for 3D ultrasound guided percutaneous needle insertion," in *Proceedings of the IEEE International Conference on Robotics and Automation, Roma, Italy* (IEEE, New York, 2007), pp. 617–622.
  - <sup>49</sup>S. E. Salcudean *et al.*, "A robotic needle guide for prostate brachytherapy," in *IEEE International Conference on Robotics and Automation* (IEEE, New York, 2008), pp. 2975–2981.
  - <sup>50</sup>T. K. Podder, I. Buzurovic, and Y. Yu, "Multichannel robot for image-guided brachytherapy," in *IEEE International Conference on Bioinformatics and Biomedical Engineering (BIBE), Philadelphia, PA* (IEEE, New York, 2010), pp. 209–213.
  - <sup>51</sup>T. Podder, I. Buzurovic, K. Huang, and Y. Yu, "Multichannel robotic system for surgical procedures," in *IASTED Symposium*, Washington, DC, 2011.
  - <sup>52</sup>S. Schreiner *et al.*, "A system for percutaneous delivery of treatment with a fluoroscopically-guided robot," *Lect. Notes Comput. Sci.* **1205**, 747–756 (1997).

- <sup>53</sup>K. Masamune *et al.*, "System for robotically assisted percutaneous procedures with computed tomography guidance," *Comput. Aided Surg.* **6**, 370–383 (2001).
- <sup>54</sup>J. Yanof, C. Bauer, and B. Wood, "Tactile feedback and display system for CT-guided, robot-assisted percutaneous procedures," in *Proceedings of the 18th International Congress and Exhibition, Computer Assisted Radiology and Surgery, International Congress Series* (Elsevier, New York, NY, 2004), Vol. 1268, pp. 521–526.
- <sup>55</sup>M. Muntener *et al.*, "Magnetic resonance imaging compatible robotic system for fully automated brachytherapy seed placement," *Urology* **68**, 1313–1317 (2006).
- <sup>56</sup>A. Patriciu *et al.*, "Automatic brachytherapy seed placement under MRI guidance," *IEEE Trans. Biomed. Eng.* **54**, 1499–1506 (2007).
- <sup>57</sup>M. R. van den Bosch *et al.*, "MRI-guided robotic system for transperineal prostate interventions: Proof of principle," *Phys. Med. Biol.* **55**, N133–N140 (2010).
- <sup>58</sup>R. Alterovitz, J. Pouliot, R. Taschereau, I.-C. Hsu, and K. Goldberg, "Simulating needle insertion and radioactive seed implantation for prostate brachytherapy," in *Medicine Meets Virtual Reality*, edited by J. D. Westwood *et al.* (IOS, 1013 BG Amsterdam, The Netherlands, 2003), Vol. 11, pp. 19–25.
- <sup>59</sup>S. P. DiMaio and S. E. Salcudean, "Needle insertion modeling and simulation," *IEEE Trans. Rob. Autom.* **19**, 864–875 (2003).
- <sup>60</sup>N. Chentanez *et al.*, "Interactive simulation of surgical needle insertion and steering," in *Proceedings of ACM SIGGRAPH*, Computer Graphics Proceedings, Annual Conference Series (ACM/ACM, New York, NY 10121, 2009).
- <sup>61</sup>O. Goksel, S. E. Salcudean, and S. P. DiMaio, "3D simulation of needle-tissue interaction with application to prostate brachytherapy," *Comput. Aided Surg.* **11**, 279–288 (2006).
- <sup>62</sup>E. Dehghan, X. Wen, R. Zahiri-Azar, M. Marchal, and S. E. Salcudean, "Needle-tissue interaction modeling using ultrasound-based motion estimation: Phantom study," *Comput. Aided Surg.* **13**, 265–280 (2008).
- <sup>63</sup>K. Yan, T. Podder, Y. Yu, T.-I. Liu, C. W. S. Cheng, and W. S. Ng, "Flexible needle-tissue interaction modeling with depth-varying mean parameter: Preliminary study," *IEEE Trans. Biomed. Eng.* **56**, 255–262 (2009).
- <sup>64</sup>D. Glozman and M. Shoham, "Flexible needle steering and optimal trajectory for percutaneous therapies," in *MICCAI 2004*, LNCS Vol. 3217 (Springer-Verlag, Berlin, 2004).
- <sup>65</sup>R. J. Webster, N. J. Cowan, G. Chirkjian, and A. M. Okamura, "Nonholonomic modelling of needle steering," in *Experimental Robotics IX*, STAR Vol. 21 (Springer-Verlag, Berlin, 2006), pp. 35–44.
- <sup>66</sup>M. Mahvash and P. E. Dupont, "Mechanics of dynamic needle insertion into a biological material," *IEEE Trans. Biomed. Eng.* **57**, 934–943 (2010).
- <sup>67</sup>S. Misra, K. B. Reed, B. W. Schafer, K. T. Ramesh, and A. M. Okamura, "Mechanics of flexible needles robotically steered through soft tissue," *Int. J. Robot. Res.* **29**, 1640–1660 (2010).
- <sup>68</sup>V. Duintam, J. Xu, R. Alterovitz, S. Sastry, and K. Goldberg, "Three-dimensional motion planning algorithms for steerable needles using inverse kinematics," *Int. J. Robot. Res.* **29**, 789–800 (2010).
- <sup>69</sup>B. Ruiz, P. Hutapea, K. Darvish, A. Dicker, Y. Yu, and T. Podder, "SMA actuated flexible needle control using EM sensor feedback for prostate brachytherapy," in *IEEE International Conference on Robotic and Automation (ICRA) 2012 Needle Steering Workshop*, St. Paul, Minnesota, May 18, 2012.
- <sup>70</sup>T. K. Podder, A. P. Dicker, Y. Yu, K. Darvish, and P. Hutapea, "A novel curvilinear approach for prostate seed implant," *Med. Phys.* **39**, 1887–1892 (2012).
- <sup>71</sup>M. J. Rivard *et al.*, "A technical evaluation of the Nucletron FIRST system: Conformance of a remote afterloading brachytherapy seed implantation system to manufacturer specifications and AAPM Task Group report recommendations," *J. Appl. Clin. Med. Phys.* **6**, 22–50 (2005).
- <sup>72</sup>L. Beaulieu *et al.*, "Bypassing the learning curve in permanent seed implants using state-of-the-art technology," *Int. J. Radiat. Oncol., Biol., Phys.* **67**, 71–77 (2007).
- <sup>73</sup>M. A. Moerland, M. J. H. van Deursen, S. G. Elias, M. van Vulpen, I. M. Jürgenliemk-Schulz, and J. J. Battermann, "Decline of dose coverage between intraoperative planning and post implant dosimetry for I-125 permanent prostate brachytherapy: Comparison between loose and stranded seed implants," *Radiother. Oncol.* **91**, 202–206 (2009).
- <sup>74</sup>T. Podder *et al.*, "Methods for prostate stabilization during transperineal LDR brachytherapy," *Phys. Med. Biol.* **53**, 1563–1579 (2008).
- <sup>75</sup>E. M. Messing *et al.*, "Intraoperative optimized inverse planning for prostate brachytherapy: Early experience," *Int. J. Radiat. Oncol., Biol., Phys.* **44**, 801–808 (1999).
- <sup>76</sup>Y. Yu *et al.*, "Automated treatment planning engine for prostate seed implant brachytherapy," *Int. J. Radiat. Oncol., Biol., Phys.* **43**, 647–652 (1999).
- <sup>77</sup>T. K. Podder, W. S. Ng, and Y. Yu, "Multi-channel robotic system for prostate brachytherapy," in *International Conference of the IEEE Engineering in Medicine and Biology Society, Lyon, France* (IEEE, New York, NY, 2007), pp. 1233–1236.
- <sup>78</sup>V. Lagerburg *et al.*, "Development of a tapping device: A new needle insertion method for prostate brachytherapy," *Phys. Med. Biol.* **51**, 891–902 (2006).
- <sup>79</sup>V. Lagerburg *et al.*, "A new robotic needle insertion method to minimize attendant prostate motion," *Radiother. Oncol.* **80**, 73–77 (2006).
- <sup>80</sup>V. Lagerburg *et al.*, "Simulation of the artifact of an iodine seed placed at the needle tip in MRI-guided prostate brachytherapy," *Phys. Med. Biol.* **53**, N59–N67 (2008).
- <sup>81</sup>M. R. van den Bosch *et al.*, "New method to monitor RF safety in MRI-guided interventions based on RF induced image artifacts," *Med. Phys.* **37**, 814–821 (2010).
- <sup>82</sup>M. Meltner, N. Ferrier, and B. Thomadsen, "Performance evaluation and optimization of a novel brachytherapy robot," *Med. Phys.* **33**, 2264 (2006).
- <sup>83</sup>M. Meltner, N. Ferrier, and B. Thomadsen, "Real-time three-dimensional position and orientation data of a brachytherapy robot using magnetic tracking," *Med. Phys.* **34**, 2507 (2007).
- <sup>84</sup>G. Fichtinger *et al.*, "Robotic assistance for ultrasound-guided prostate brachytherapy," *Med. Image Anal.* **12**, 535–545 (2008).
- <sup>85</sup>D. Stoianovici, "Multi-imager compatible actuation principles in surgical robotics," *Int. J. Med. Robot.* **1**, 86–100 (2005).
- <sup>86</sup>D. Stoianovici *et al.*, "MRI Stealth robot for prostate interventions," *Minim. Invasiv. Ther. Allied. Technol.* **16**, 241–248 (2007).
- <sup>87</sup>M. A. Muntener *et al.*, "Transperineal prostate intervention: Robot for fully automated MR imaging—system description and proof of principle in a canine model," *Radiology* **247**, 543–549 (2008).
- <sup>88</sup>J. A. Cunha *et al.*, "Toward adaptive stereotactic robotic brachytherapy for prostate cancer: Demonstration of an adaptive workflow incorporating inverse planning and an MR stealth robot," *Minim. Invasive Ther. Allied Technol.* **19**, 189–202 (2010).
- <sup>89</sup>A. Krieger *et al.*, "Design of a novel MRI compatible manipulator for image guided prostate interventions," *IEEE Trans. Biomed. Eng.* **52**, 306–313 (2005).
- <sup>90</sup>A. Krieger *et al.*, "An MRI-compatible robotic system with hybrid tracking for MRI-guided prostate intervention," *IEEE Trans. Biomed. Eng.* **58**, 3049–3060 (2011).
- <sup>91</sup>G. S. Fischer *et al.*, "MRI compatibility of robot actuation techniques—A comparative study," *Med. Image Comput. Comput. Assist. Interv.* **11**(Pt. 2), 509–517 (2008).
- <sup>92</sup>G. S. Fischer *et al.*, "MRI-compatible pneumatic robot for transperineal prostate needle placement," *IEEE/ASME Trans. Mechatron.* **13**(3), 295–305 (2008).
- <sup>93</sup>J. Tokuda *et al.*, "Preclinical evaluation of an MRI-compatible pneumatic robot for angulated needle placement in transperineal prostate interventions," *Int. J. Comput. Assist. Radiol. Surg.* **7**(6), 949–957 (2012).
- <sup>94</sup>Z. Wei *et al.*, "3D TRUS guided robot assisted prostate brachytherapy," *Med. Image Comput. Comput. Assist. Interv.* **8**, 17–24 (2005).
- <sup>95</sup>N. Hung *et al.*, "Design of an ultrasound-guided robotic brachytherapy needle-insertion system," in *Proceedings of the Annual International Conference of the IEEE Engineering in Medicine and Biology Society* (IEEE, New York, NY, 2009), pp. 250–253.
- <sup>96</sup>A. L. Trejos, R. V. Patel, and R. A. Malthaner, "A device for robot assisted minimally invasive lung brachytherapy," in *Proceedings of the 2006 IEEE International Conference on Robotics and Automation, Orlando, FL, May 15–19* (IEEE, New York, 2006), pp. 1487–1492.
- <sup>97</sup>A. L. Trejos *et al.*, "Robot-assisted minimally invasive lung brachytherapy," *Int. J. Med. Robot.* **3**, 41–51 (2007).
- <sup>98</sup>A. L. Trejos, S. Mohan, H. Bassan, A. W. Lin, M. Pytel, A. Kashigar, R. V. Patel, and R. A. Malthaner, "An experimental test-bed for robotics-assisted image-guided minimally invasive lung brachytherapy," in *IEEE/RSJ International Conference on Intelligent Robots and Systems*, San Diego, CA, October 29–November 2, 2007.
- <sup>99</sup>A. L. Trejos *et al.*, "MIRA V: An integrated system for minimally invasive robot-assisted lung brachytherapy," in *2008 IEEE International Conference on Robotics and Automation*, Pasadena, May 19–23, 2008.

- <sup>100</sup>R. Nath *et al.*, "AAPM recommendations on dose prescription and reporting methods for permanent interstitial brachytherapy for prostate cancer—Report of Task Group 137," *Med. Phys.* **36**, 5310–5322 (2009).
- <sup>101</sup>D. Ash, A. Flynn, J. Battermann, T. de Reijke, P. Lavagnini, and L. Blank, "ESTRA/EAU Urological Brachytherapy Group; EORTC Radiotherapy Group, ESTRO/EAU/EORTC recommendations on permanent seed implantation for localized prostate cancer," *Radiother. Oncol.* **57**, 315–321 (2000).
- <sup>102</sup>A. Salembier, P. Lavagnini, P. Nickers, P. Mangili, A. Rijnders, A. Polo, J. Venselaar, P. Hoskin, and GEC ESTRO PROBATE Group, "Tumour and target volumes in permanent prostate brachytherapy: A supplement to the ESTRO/EAU/EORTC recommendations on prostate brachytherapy," *Radiother. Oncol.* **83**, 3–10 (2007).
- <sup>103</sup>B. J. Davis, E. M. Horwitz, J. M. Crook, R. G. Stock, G. S. Merrick, W. M. Butler, P. D. Grimm, N. N. Stone, L. Potters, A. L. Zietman, and M. J. Zelefsky, "American Brachytherapy Society consensus guidelines for transrectal ultrasound-guided permanent prostate brachytherapy," *Brachytherapy* **11**, 6–9 (2012).
- <sup>104</sup>M. F. Dempsey, B. Condon, and D. M. Hadley, "MRI safety review," *Semin. Ultrasound CT, MR* **23**, 392–401 (2002).
- <sup>105</sup>A. Condon, D. M. Hadley, and R. Hodgson, "The ferromagnetic pillow: A potential MR hazard not detectable by a hand-held magnet," *Br. J. Radiol.* **74**, 847–851 (2001).
- <sup>106</sup>A. Zimmer, M. N. Janssen, T. A. Treschan, and J. Peters, "Near-miss accident during magnetic resonance imaging by a flying sevoflurane vaporizer due to ferromagnetism undetectable by handheld magnet," *Anesthesiology* **100**, 1329–1330 (2004).
- <sup>107</sup>J. F. Schenck, "Safety of strong, static magnetic fields," *J. Magn. Reson. Imaging* **12**, 2–19 (2000).
- <sup>108</sup>S. M. Park, R. Kamondetdacha, and J. A. Nyenhuis, "Calculation of MRI-induced heating of an implanted medical lead wire with an electric field transfer function," *J. Magn. Reson. Imaging* **26**, 1278–1285 (2007).
- <sup>109</sup>J. Yeung, R. C. Susil, and E. Atalar, "RF heating due to conductive wires during MRI depends on the phase distribution of the transmit field," *Magn. Reson. Med.* **48**, 1096–1098 (2002).
- <sup>110</sup>J. Pictet, R. Meuli, S. Wicky, and J. J. van der Klink, "Radiofrequency heating effects around resonant lengths of wire in MRI," *Phys. Med. Biol.* **47**, 2973–2985 (2002).
- <sup>111</sup>J. Yeung, P. Karmarkar, and E. R. McVeigh, "Minimizing RF heating of conducting wires in MRI," *Magn. Reson. Med.* **58**, 1028–1034 (2007).
- <sup>112</sup>M. K. Konings, L. W. Bartels, H. F. M. Smits, and C. J. G. Bakker, "Heating around intravascular guidewires by resonating RF waves," *J. Magn. Reson. Imaging* **12**, 79–85 (2000).
- <sup>113</sup>M. F. Dempsey, B. Condon, and D. M. Hadley, "Investigation of the factors responsible for burns during MRI," *J. Magn. Reson. Imaging* **13**, 627–631 (2001).
- <sup>114</sup>M. R. van den Bosch, M. A. Moerland, J. J. Lagendijk, L. W. Bartels, and C. A. van den Berg, "New method to monitor RF safety in MRI-guided interventions based on RF induced image artifacts," *Med. Phys.* **37**, 814–821 (2010).
- <sup>115</sup>M. S. Huq *et al.*, "Application of risk-analysis methods to radiation-therapy quality management: Report of the AAPM Task Group 100" (unpublished).
- <sup>116</sup>L. Fu, H. Liu, R. Brasacchio, D. Rubens, J. Strang, E. Messing, and Y. Yu, "Clinical observation and modeling of postimplant seed displacement for prostate brachytherapy," *Int. J. Radiat. Oncol., Biol., Phys.* **63**, S504–S505 (2005).
- <sup>117</sup>R. Taschereau, J. Pouliot, J. Roy, and D. Tremblay, "Seed misplacement and stabilizing needles in transperineal permanent prostate implants," *Radiother. Oncol.* **55**, 59–63 (2000).
- <sup>118</sup>T. Podder, L. Beaulieu, B. Caldwell, R. Cormack, J. Crass, A. Dicker, A. Fenster, G. Fichtinger, M. Meltsner, M. Moerland, R. Nath, M. Rivard, T. Salcudean, D. Song, B. Thomadsen, and Y. Yu, "Validation of the AAPM/ESTRO TG-192 protocol for robotic implantation of brachytherapy seeds: Spatial positioning assessment," *Med. Phys.* **39**, 3933 (2012).
- <sup>119</sup>D. Pfeiffer, S. Sutlief, W. Feng, H. M. Pierce, and J. Kofler, "AAPM Task Group 128: Quality assurance tests for prostate brachytherapy ultrasound systems," *Med. Phys.* **35**, 5471–5489 (2008).
- <sup>120</sup>S. Diamantopoulos *et al.*, "Effect of using different U/S probe Standoff materials in image geometry for interventional procedures: The example of prostate," *J. Contemp. Brachytherapy* **3**, 209–219 (2011).
- <sup>121</sup>T. Willoughby, J. Lehmann, J. A. Bencomo, S. K. Jani, L. Santanam, A. Sethi, T. D. Solberg, W. A. Tome, and T. J. Watson, "Quality assurance for nonradiographic radiotherapy localization and positioning systems: Report of Task Group 147," *Med. Phys.* **39**, 1728–1747 (2012).
- <sup>122</sup>N. Hungr *et al.*, "A realistic deformable prostate phantom for multimodal imaging and needle-insertion procedures," *Med. Phys.* **39**, 2031–2041 (2012).