

AC Coupling Technique for Josephson Waveform Synthesis

Samuel P. Benz, Charles J. Burroughs, and Paul D. Dresselhaus

Abstract—We demonstrate a new bias technique that uses low-pass and high-pass filters to separate the current paths of the sampling and signal frequencies in a Josephson waveform synthesizer. This technique enables the output voltage of the array to be directly grounded by removing the low-frequency common mode signal that previously prevented direct measurement of the array voltage with low-impedance instruments. We directly measure the harmonic spectra of 1 kHz and 50 kHz synthesized sine waves. We also use a thermal transfer standard to compare the rms voltages of synthesized sine waves at frequencies from 1 kHz to 50 kHz. Finally, we describe a new circuit that should enable a significant increase in output voltage by allowing several distributed arrays to be biased in parallel at high frequency, while combining their low frequency output voltages in series.

Index Terms—Josephson junction, digital synthesis, voltage standard, arbitrary waveform.

I. INTRODUCTION

THE Josephson arbitrary waveform synthesizer is capable of synthesizing ac and dc voltages as well as arbitrary waveforms [1]-[3]. Achieving output voltages of 1 V or more is one of the remaining challenges for making it a practical ac voltage standard and arbitrary waveform synthesizer. A number of methods have been proposed to address the need for higher voltage. For example, a bipolar waveform technique, in which a high-frequency sine wave is added to the broadband digital code input signal, has resulted in a six-fold increase in output voltage [4]. Another idea for increasing output voltage is the use of lumped arrays, in which all of the junctions are spaced within one-eighth to one-quarter of the wavelength of the highest drive frequency [5], [6]. Using lumped arrays would increase the output voltage to more than three times that of a distributed array, assuming junctions with the same electrical characteristics. In this paper, we describe a new technique for biasing series arrays and demonstrate more than a ten-fold increase in directly coupled output voltage compared to previous voltage comparisons [7]. We also describe circuit modifications which, when combined with this technique, have the potential to achieve even higher voltages through the use of multiple arrays.

We have been developing an ac voltage standard based on controlling the perfectly quantized voltage pulses of

Josephson junctions since 1996 [1]. The time-integrated area of every Josephson pulse is precisely equal to the flux quantum, $h/2e$, the ratio of Planck's constant to twice the elementary electron charge. Digital synthesis using these perfectly quantized pulses enables the generation of voltage waveforms with unprecedented accuracy and stability. After many improvements, we recently demonstrated a Josephson circuit that can synthesize arbitrary waveforms with low harmonic distortion and stable, calculable, and reproducible voltage amplitude and phase [7], [8]. This precision synthesized source will be useful in high-performance audio and radio-frequency (rf) applications, including ac voltage standards, low-noise radar, and electronic instrument calibration.

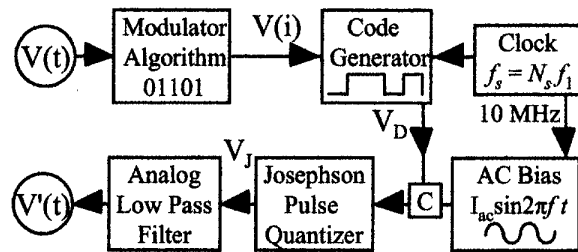

Fig. 1. Block diagram of the bipolar bias method for the Josephson arbitrary waveform synthesizer. The digital-code input signal is directly coupled to the Josephson junction pulse-quantizing array.

We previously described and demonstrated a method for synthesizing bipolar waveforms in which the array is driven with a combined input waveform consisting of the two-level digital code and a sine wave [4], [9]. Fig. 1 shows the block diagram for the bipolar method when the digital code signal is directly coupled to the Josephson pulse quantizer. The modulator algorithm converts the desired analog waveform $V(t)$ into a 'perfect' digital code of ones and zeros. A delta-sigma modulator algorithm is used [10] to reduce in-band distortion from the quantization process, called quantization noise, by pushing it out of band, usually to higher frequencies. We use a second-order two-level delta-sigma modulator algorithm that has been modified for optimal use with this bipolar bias technique. The periodic code of length N_s is loaded into the circulating memory of a semiconductor code generator, which attempts to reproduce the ideal digital code with its two-level output. The array is biased by the combined signal of the code generator and a sine wave with frequency f through a directional coupler 'C'. The low-pass filter removes the out-of-band quantization noise and produces the desired

Manuscript received 19 September 2000. This work is a contribution of an agency of the U.S. Government and is thus not subject to U.S. copyright. This work was supported in part by Office of Naval Research contracts N00014-99-F-0127 and N00014-00-F-0154.

synthesized signal $V'(t)$. For a clock (and sampling) frequency f_s , the minimum signal frequency is $f_j = f_s/N_s$.

The maximum output voltage of a series array of junctions is $V = nNf(h/2e)$, where n is the number of quantized output pulses per input pulse, N is the number of series junctions, f is the sine wave frequency, h is Planck's constant, and e is the electron charge. The area $h/2e$ of each quantized pulse is very small, approximately $2 \mu\text{V}/\text{GHz}$. In order to generate a waveform with a 1 V peak amplitude, approximately 5×10^{14} pulses/s must be synthesized and controlled. Thus, high voltage output requires both many junctions and a high pulse-repetition frequency.

The optimum operating margins occur when the sine frequency is an odd half-integer multiple of the clock frequency f_s (eg. $3/2$, $5/2$) [4], so that higher sine wave frequencies can produce higher output voltages with a fixed maximum clock frequency. The relative phase between the clock and the sine wave is maintained with a 10 MHz reference signal. In this bipolar method, the maximum output voltage gives a six-fold increase in peak-to-peak voltage (for $f = 3f_s/2$) compared to unipolar methods using the same code generator [4].

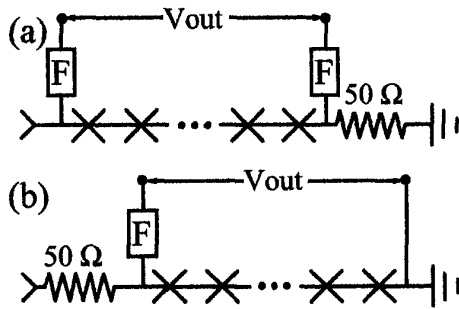

Fig. 2. Josephson pulse quantizer circuits. Each array of N junctions (junction symbol \times) is embedded in a 50Ω coplanar waveguide transmission line. The bipolar input signal drives the transmission line from the left side. (a) Typical distributed-array configuration with two identically filtered output taps F where the transmission line is terminated after the array. (b) Low common-mode configuration with a single filtered output tap where the lumped array is directly grounded.

The ac coupling technique described below is necessary for two reasons: (1) existing fabrication technology limits the number of junctions and thus the voltage for lumped arrays and (2) a common mode voltage arises when the broadband digital code signal is directly coupled to distributed arrays. Figure 2 shows schematics of both distributed and lumped series array circuits that we have used in previous measurements. Each array is embedded in a 50Ω coplanar waveguide transmission line. The digital signal and sine wave drive are applied to the transmission line on the left side. The array output voltage is measured through low-pass filters that ensure that the broadband signal remains on the transmission line and drives each junction uniformly. For the configuration in Fig. 2(a), 4096 junctions are typically distributed over about 29 mm. We have achieved the largest output voltages with this circuit because of the large number of junctions. The digital code contains the same frequency component as the

desired output signal from the array. Thus, a common mode signal occurs across the termination resistor when the digital signal is directly coupled to the array. In all previous measurements of this circuit, a high-impedance preamp was thus required to remove the common-mode signal. AC metrology calibrations, which require direct coupling of the array voltage, are not possible using this circuit configuration and bias method.

The lumped array shown in Fig. 2(b) typically has 250 junctions spaced over 1.8 mm. This array can be considered lumped up to about 17 GHz. If we had a nanoscale junction fabrication technology that could place 13 000 junctions in this same length, yielding a total array impedance of 50Ω , then we would not need the termination resistor. A termination resistor is required because the resistance of our 250-junction array of $2 \mu\text{m}$ diameter junctions is only about 1Ω . However, the array can be directly grounded by placing the termination on the ungrounded side of the array. This unusual termination effectively removes the common-mode voltage, but a lumped array is required because larger arrays would lead to standing waves that distort the input drive signal and reduce the operating margins. All of our previous ac-metrology measurements and voltage comparisons were performed using this lumped circuit [7]. However, this approach is inadequate for most metrology applications because the small number of junctions limits the output voltage to about 3.6 mV.

II. AC COUPLING

In the present work, we use an ac-coupled bias method to remove the common-mode signal. This allows us to use distributed arrays, which presently achieve the largest output voltage for applications that require direct coupling. The block diagram of this technique is shown in Fig. 3. It is similar to the directly coupled block diagram shown in Fig. 1 except that the digital code signal is now ac coupled to the array. In the experiments described below, ac coupling is accomplished by using an SMA inner and outer conductor "dc block" with a 10 MHz to 18 GHz pass band. The dc block is indicated by the capacitor symbol in the circuit schematic. All signals with frequencies below 10 MHz are

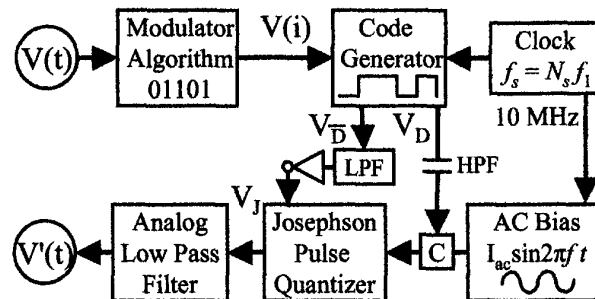

Fig. 3. Block diagram of the ac-coupled input bias technique for bipolar waveforms of the Josephson arbitrary waveform synthesizer. High-frequency signals from the digital code generator are ac coupled to the array through a dc blocking capacitor (HPF) while the low-frequency bias is applied separately through the low pass filter (LPF) and amplifier.

effectively removed from the broadband input bias. With ac coupling, the distributed array circuit in Fig. 2(a) can be used for direct measurements because there is no common mode voltage at the signal frequency on the termination resistor.

However, the low-frequency part of the original digital code signal is necessary for biasing the array. We reapply the low-frequency bias to the array through the low-pass filters shown in Fig. 2(a). A common mode signal is not created because this current doesn't flow through the termination resistor. For the experiments described in this paper, we recreate the low-frequency bias by using the data bar signal, indicated by V_D^- in Fig. 3. This signal is inverted with respect to the data signal V_D . We use a low-pass filter to remove the high-frequency signals and we obtain the correct phase and amplitude for the low-frequency signal by using an inverting amplifier with an adjustable gain. The low-frequency signal is applied to the on-chip filters and the array through 1 m long twisted-pair leads. The array output voltage is measured through separate twisted-pair leads and through a different pair of on-chip pads that make superconducting connections to the on-chip filters.

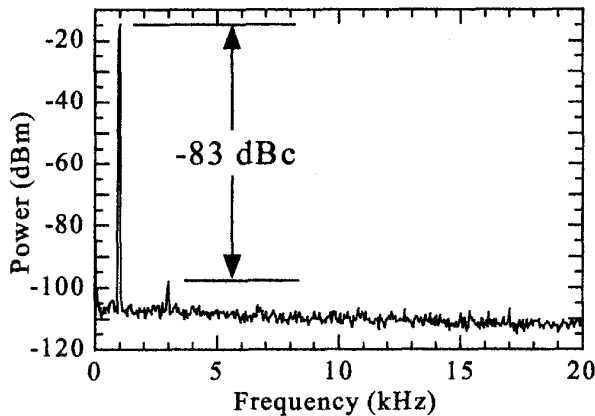

Fig. 4. Directly measured spectrum of a 1 kHz sine wave synthesized with the ac-coupled bipolar technique. The resolution bandwidth is 1 Hz.

In this paper we use the same 4096-junction distributed array described in previous papers [7], [8]. The junctions are 2 μm diameter Nb-PdAu-Nb superconductor-normal metal-superconductor junctions. The on-chip bias taps to the array are 3 GHz low-pass filters each having a pair of 2.7 nH square-coil inductors that are 114 μm on a side. The array has an 8.2 mA critical current and a resistance per junction of 2.7 m Ω . The array is biased with a 7.5 GHz sine wave and the digital code is clocked at 3 GHz ($f = 5f_s/2$).

III. AC VOLTAGE MEASUREMENTS

We previously performed ac voltage comparisons using the lower-voltage 250-junction lumped array [7]. We synthesized five sine waves from 1 kHz to 50 kHz, each with a 3 000 064 bit code length and 3.65 mV rms amplitude. The peak amplitude of each of these sine waves is 0.95 times the maximum voltage for a 10.5 GHz sinusoidal drive frequency. Using the 4096-junction distributed array, the ac coupling

technique, and a slightly lower 7.5 GHz sine frequency, we can synthesize these same sine waves with more than 10 times larger voltage, about 42.7 mV rms amplitude.

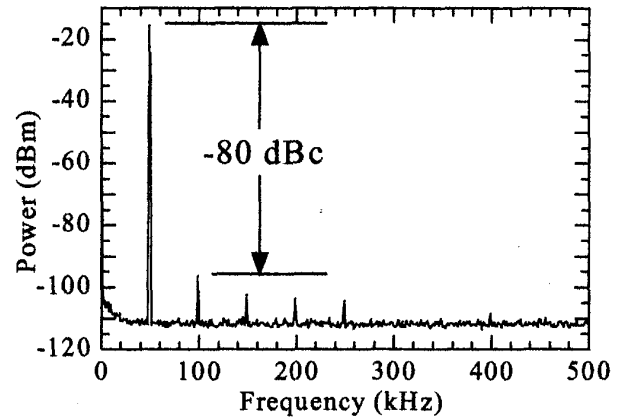

Fig. 5. Directly measured spectrum of a 50 kHz sine wave synthesized with the ac-coupled bipolar technique. The resolution bandwidth is 1 Hz.

Since the ac-coupled technique allows the array output voltage to be referenced to ground, we can directly measure the array voltage with a spectrum analyzer or other low impedance instrument. Figures 4 and 5 show the first directly measured spectra of the Josephson arbitrary waveform synthesizer without the use of a preamplifier to remove common mode signals. The harmonic distortion for both the 1 kHz and 50 kHz synthesized waveforms is at least 80 dB below the fundamental [-80 dBc (carrier)]. The waveforms are measured with a 10 MHz fast Fourier transform (FFT) spectrum analyzer with a harmonic distortion specification of -75 dBc. Distortion induced by inadequate operating margins on the array would most likely appear at all multiples of the 1 kHz minimum frequency of the periodic 3 000 064-bit digital code for both waveforms. The fact that the spectrum of the 50 kHz waveform shows distortion harmonics only at multiples of 50 kHz and none at 1 kHz intervals suggests that these peaks may be a measure of the spectrum analyzer's harmonic distortion.

TABLE I
MEASURED AC TO 1 KHz DIFFERENCES

Frequency (kHz)	Josephson Source (parts in 10^6) ^a
3	+3.1 \pm 1.5
10	+25.9 \pm 0.9
20	+6.6 \pm 1.4
50	-147.6 \pm 2.4

Comparison were made using a commercial thermal transfer standard.

^a The Josephson source data uncertainty is Type A ($k=2$).

We also made voltage comparisons with a commercial, amplifier-aided, thermal transfer standard that uses a differential thermal converter to provide a dc signal proportional to the rms voltage of the input signal. The measured ac to 1 kHz rms voltage differences shown in

Table I are a comparison of the voltage of the four highest-frequency synthesized waveforms with the voltage of the 1 kHz waveform. The voltage differences for all of these frequencies are at least ten-times smaller than the previously measured differences that were determined using the lower voltage lumped array [7]. The measured ac to 1 kHz differences from 3 kHz to 20 kHz agree with the frequency-dependent scatter that we expect from the thermal transfer standard. However, the 50 kHz to 1 kHz difference is lower than expected, so other error sources are evaluated below.

We also measured the voltage error induced by inductance in series with the array, which includes inductance from the on-chip low-pass filters. These data are shown in Table II. The measured voltages agree with the expected voltages for the estimated series inductance. The inductive voltages are rather large (tens of microvolts compared to the 43 mV output voltage); however, since they are 90 degrees out of phase with respect to the array voltage, they contribute less than 2 parts in 10^6 to the measured ac to 1 kHz voltage differences in Table I. Thus the inductive signal is probably not a significant contribution to the ac to 1 kHz voltage differences.

TABLE II
LOW-FREQUENCY INPUT-OUTPUT COUPLING

Frequency (kHz)	Measured Coupling (μV) ^a	Contribution to Rms Voltage (parts in 10^6) ^b
1	3 ± 1	0.001
3	4 ± 1	0.005
10	14 ± 1	0.06
20	27 ± 1	0.2
50	68 ± 1	1.3

The low-frequency input-output coupling was measured with the high-frequency digital code generator and sine wave signals turned off.

^a The Josephson source data uncertainty is Type A ($k=2$).

^b Estimated contribution to the total rms voltage for the Josephson array shown in Table I.

Input-output coupling is probably the dominant source of error in our present measurements. Our initial measurements using the ac-coupling technique found the 50 kHz-1 kHz voltage difference to be 3800 parts in 10^6 . We originally used straight bias leads for both the low frequency input signal and the array output signal. The extremely large voltage difference was due to strong input-output coupling between the low-frequency leads as a result of the low-frequency bias for the ac coupling technique. The input-output coupling was dramatically reduced (to the values in Table II) when we switched to twisted pair leads for both the input and output signals. Further reduction in input-output coupling should allow us to perform useful comparisons at hundreds of kilohertz and even megahertz frequencies.

IV. SERIES-CONNECTED ARRAYS

The above demonstration of the ac-coupling technique for the Josephson arbitrary waveform synthesizer allows us to conceive of increasing the output voltage even further. This can be accomplished by connecting multiple arrays in series for low frequencies while driving the arrays in parallel at high

frequencies. This technique has been used for dc Josephson array voltage standards for many years [12], [13], but was not considered feasible until now for the ac standards because of the broadband frequency requirements of the digital code signal.

One scheme for series connecting multiple arrays is shown in Fig. 6. Each array can be biased with independent digital code generators that are mutually synchronized. A single code generator can also be used to create multiple parallel high-frequency signals provided that a voltage divider or splitter with sufficient bandwidth is used and amplifiers with sufficient bandwidth and gain are available. Likewise, a single low-frequency bias source can be used to bias all of the series arrays together as long as the inductive voltage does not become too large. Separate low-frequency bias sources can be used for each array if operating margins are too small or if inductive voltages are too large. Small-area, on-chip capacitors, although not essential, will be helpful in enabling this technology.

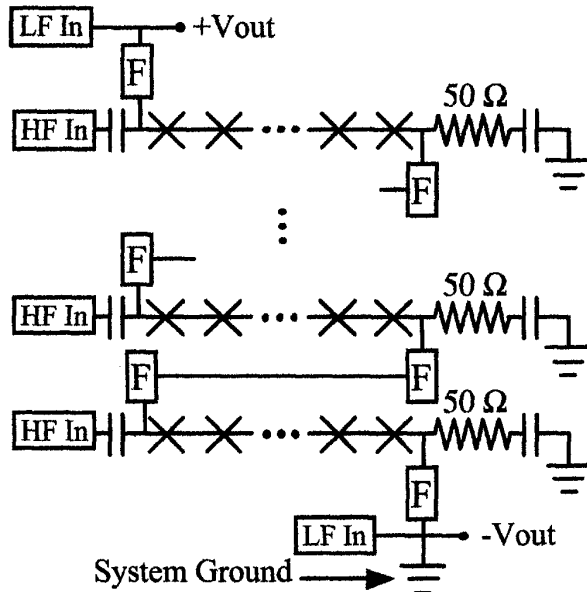

Fig. 6. Circuit schematic using multiple arrays to achieve higher output voltage. The arrays are in parallel for the ac-coupled high-frequency input signals and in series for low-frequency (LF) signals. 'F's indicate low pass filters. The grounds on the right side represent the transmission line ground return paths for the high frequency (HF) digital code and sine wave signals. The system ground indicates how the array voltage is directly grounded.

V. SUMMARY

We demonstrate a new technique for biasing a Josephson arbitrary waveform synthesizer. We present the first spectra that were directly measured from the array without the use of an isolating preamplifier. Comparisons are made between synthesized voltages at different frequencies and a synthesized 1 kHz waveform that show a ten-fold improvement in the voltage difference compared to previous voltage comparisons. Finally, we propose a method to increase the output voltage by connecting several arrays in series.

ACKNOWLEDGMENTS

The authors thank Joe Kinard, Tom Lipe, and Mark Parker for providing us with a thermal transfer standard and their expertise in this area. We appreciate discussions with John Martinis about input waveforms with no dc component, which encouraged us to consider ac coupling using the bipolar technique. We also thank Clark Hamilton and Laurie Christian for many helpful conversations.

REFERENCES

- [1] S. P. Benz and C. A. Hamilton, "A pulse-driven programmable Josephson voltage standard," *Appl. Phys. Lett.*, vol. 68, pp. 3171-3173, May 1996.
- [2] S. P. Benz, C. J. Burroughs, and C. A. Hamilton, "Operating margins for a pulse-driven programmable voltage standard," *IEEE Trans. Appl. Supercond.*, vol. 7, pp. 2653-2656, June 1997.
- [3] S. P. Benz, C. A. Hamilton, C. J. Burroughs, T. E. Harvey, L. A. Christian, and J. X. Przybysz, "Pulse-driven Josephson D/A Converter," *IEEE Trans. Appl. Supercond.*, vol. 8, pp. 42-47, June 1998.
- [4] S. P. Benz, C. A. Hamilton, C. J. Burroughs, and T. E. Harvey, "AC and dc bipolar voltage standard using quantized pulses," *IEEE Trans. Instrum. Meas.*, vol. 48, pp. 266-269, April 1999.
- [5] R. H. Ono and S. P. Benz, "Optimum characteristics of high temperature Josephson junctions for lumped array applications," in *Proceedings of the 7th International Superconductive Electronics Conference (ISEC'99)*, 21-25 June 1999, Berkeley, pp. 301-303.
- [6] S. P. Benz, C. J. Burroughs, and P. D. Dresselhaus, "Nanotechnology for next generation Josephson voltage standards," proceedings of the Symposium on Microtechnology in Metrology and Metrology in Microsystems, 31 August-1 September 2000, Delft University of Technology, Delft, The Netherlands, pp. 127-132.
- [7] S. P. Benz, C. J. Burroughs, P. D. Dresselhaus, and L. A. Christian, "AC and DC Voltages from a Josephson Arbitrary Waveform Synthesizer, to appear in *IEEE Trans. Instrum. Meas.*, Vol. 50, No. 2 (April 2001).
- [8] S. P. Benz, C. J. Burroughs, and P. D. Dresselhaus, "Harmonic distortion in a Josephson arbitrary waveform synthesizer," *Appl. Phys. Lett.*, vol. 77, No. 7, pp. 1014-1016, August 2000.
- [9] S. P. Benz, C. J. Burroughs, T. E. Harvey, and C. A. Hamilton, "Operating conditions for a pulse-quantized ac and dc bipolar voltage source," *IEEE Trans. Appl. Supercond.*, vol. 9, pp. 3306-3309, June 1999.
- [10] J. C. Candy, "An Overview of Basic Concepts," in *Delta-Sigma Data Converters: Theory, Design, and Simulation*, S. R. Norsworthy, R. Schreier and G. C. Temes, Eds., Piscataway, N.J.: IEEE Press, 1997, pp. 1-43.
- [11] R. L. Kautz, "Design and operation of series-array Josephson voltage standards," in *Metrology at the Frontiers of Physics and Technology*, L. Grovini and T. J. Quinn, Eds., Amsterdam: North-Holland, 1992, p. 259-296.
- [12] J. Niemeyer, "Josephson voltage standards," in *Handbook of Applied Superconductivity*, vol. 2, Bernd Seeber, Ed., Philadelphia: Inst. of Physics Publishing, 1998, p. 1813-1834.