

MTI Report 95TR29

ACCELERATED TESTING OF SPACE MECHANISMS

S. Frank Murray and Hooshang Heshmat
Mechanical Technology Incorporated
Latham, New York

Robert Fusaro, Technical Representative
National Aeronautics and Space Administration
Lewis Research Center
Cleveland, Ohio

April 1995

Prepared under:
Contract NAS3-27086

Prepared for:
National Aeronautics and Space Administration
Lewis Research Center
21000 Brookpark Road
Cleveland, Ohio 44135

The NASA logo, consisting of the word "NASA" in a bold, sans-serif font.

PREFACE

Scope of the Program

Under NASA Contract NAS3-27086, Mechanical Technology Inc. has been conducting a Space Mechanisms - Lessons Learned Study. To take full advantage of the technical information being obtained from the literature and contractor surveys in connection with that study, additional tasks were identified. These were as follows:

Task V Accelerated Testing Information Retrieval Study

- Determination of significant mechanical components for space which would benefit from accelerated test techniques.
- Determination of Shortfalls and Future Needs: Current types of accelerated testing techniques, their shortfalls and need to develop new techniques.
- Data evaluation and characterization, by component type, of mechanical system and satellite applications, accelerated test methods, if any, and parameters needing to be evaluated.
- Preparation of an Informational Retrieval Report. This report shall contain a listing of current accelerated test methods and an evaluation of their effectiveness. It should also contain a definition of needs study.

Task V1 Development of Accelerated Testing Technology Road Map

- Develop a plan for assessing the life and reliability of spacecraft mechanical systems by accelerated test methods. The plan should consist of integrating systems components testing, analytical modelling, computer codes, computer smart systems, etc., into a methodology that could be used to predict or verify the life and reliability of a mechanical system.

Task V11 Develop a Demonstration Program

- Based on the results of the accelerated testing technology "roadmap" study, a space mechanism mechanical system or component should be selected to demonstrate that the methods developed will adequately predict the life and/or performance of a mechanism. A plan should be developed for demonstrating the accelerated methods including experimental equipment, test procedure, time guideline and cost analysis.

This report describes the results of the additional tasks V to V11.

The first step toward achieving the goals of these additional tasks was to convene a Space Mechanisms Workshop at the NASA Lewis Research Center to review the problem of Accelerated Testing of Mechanisms. A letter report, dated May 17, 1994, was prepared by Dr. Hooshang Heshmat⁽¹⁾. That letter report summarized the consensus of the Workshop regarding accelerated testing.

1. IDENTIFYING MECHANISMS IN NEED OF ACCELERATED TESTING

As shown in Table 1-1, a number of mechanisms were identified which could benefit from accelerated testing. Each of these mechanisms depends on certain components for reliable operation. In Table 1-2, a list of these components, as recommended and prioritized by the Workshop participants, is presented.

The next question that was addressed by the Workshop was concerned with Identifying Currently Used Accelerated Testing Techniques:

To date, predictions of long term performance have been based on: A) Past experience; or B) Full scale tests at higher cycle rates than the normal duty cycle.

Table 1-1. Identified Mechanisms in Need of Accelerated Testing

<ol style="list-style-type: none">1. Momentum/Reaction Wheels2. Gyros3. Scanning Earth Sensors4. Solar Array Devices5. De Spin Mechanisms6. Stepper Motors, et al.7. Storage Life Deployment Mechanisms8. On Orbit Life Issue for Planetary Mission9. Speed Reducers, Gears, Harmonic Drive10. Slider Devices (linear act. ...)
--

95TR29

Table 1-2. Components Needed for Reliable Operation of Space Mechanisms

<ol style="list-style-type: none">1. Rolling Element Bearings2. Journal Bearings3. Slider Bearings4. Slip Rings5. Commutators6. Gears7. Flex Harnesses, Cables8. Low Cycle Devices – Spring, Switches, Cams, etc.
--

95TR29

Acceleration has generally been achieved by increasing speed and temperature, or increasing speed and load. Reducing the quantity of available lubricant, and varying surface roughness, have also been used. In addition to these accelerated test methods, monitoring of the condition of mechanisms actually operating in space could be considered as Orbit Real Time Testing.

The Chairman raised a question about using better testing to address Reliability Issues while developing promising accelerated test techniques. The consensus was affirmative if the following requirements were met:

- a) Thorough knowledge of bearing operating conditions and lubricant.
- b) Tests must bracket extreme conditions.
- c) Test results and predictive model were verified by Orbit Real Time tests.
- d) Standardization of testing methods was developed.

To summarize:

2. IDENTIFY CURRENT ACCELERATED TEST TECHNIQUES

- 1) Real Time Testing - up to 5 years
- 2) Duty Cycle - (not including idle time)
- 3) Accelerated Tests - Increase temperature, speed, load, contaminants, or surface roughness; or decrease available lubricant.
- 4) Use Orbit Real Time Testing

Improved testing can be used to address Reliability Issues if the following requirements are met: 1) Known bearing loads and operating conditions; 2) Extreme conditions are bracketed; 3) Tests are used to verify the model; lubricants are known.

Referring back to Item 2, Currently Used Accelerated Techniques, the Workshop participants discussed each item's strength and weakness. Except for Real Time Tests in Orbit, laboratory testing cannot adequately simulate the lack of gravity. Real Time tests are costly and impractical, although they would provide a one-to-one comparison. Duty Cycle poses the question that idle time in storage, or in orbit but not being actuated is still penalizing component life because of chemical changes and other time dependent properties. To summarize:

3. IDENTIFY ACCELERATED TESTING STRENGTH AND WEAKNESS

1) Real Time Testing	Weakness - Cost, Non-standardized, does not bracket test conditions Strength - Useful for 1-1 comparison
2) Neglecting Duty Cycle	Weakness - Does not include long time chemical or physical changes Strength - Saves money and time, good compromise
3) Use of Accelerated Testing	Weakness - Wetting condition with temperature Chemistry changes with temperature & pressure Oxidation changes with temperature & pressure Hydrodynamics region changes Wear/friction polymers (cages) changes Coating Fracture - under high load (solid lube) Non-Standardized Dynamic changes in cage & components Low confidence Strength - Easy to monitor Use to enhance design Use to validate model Data generation (base)
4) Orbit Real Time Testing	Weakness - Similar to Item #1 above Strength - Use to verify ground test

In general, the approach to accelerated testing needs a better understanding of significant parameters and failure mechanisms. There is also a need for a parallel effort with a lubrication system operating in Real Time Orbit so that the results of the accelerated tests can be properly evaluated. This would be Item 4, Orbit Real Time Testing.

The results of the Workshop were encouraging because they showed that an accelerated test development program could lead to both an in-depth understanding of the space lubrication mechanisms problem and reliable tests for projecting accurate service life as well as a database for design.

4. IDENTIFY KNOWLEDGE NEEDED TO RESOLVE ACCELERATED TESTING WEAKNESSES

- Creep Properties of Lubes
- Lube Loss (Migration & Retention), out-gassing
- Time Dependent Environment
- Stroke Angle for Gimbals
- Lube Additives
- Launch Condition
- Simulate all Conditions, if practical (Ground/Test/Launch/Release, etc.)
- Tolerances & Dimensions

In general, members of the panel recommended that the proper approach to accelerated testing should consider factors that contribute to the aging of the components, in particular ball bearings that are operating in the boundary lubrication region. To address the problem of understanding the actual time dependent failure modes, they recommended the proper study of an integrated accelerated life testing that would incorporate the needed knowledge as highlighted below:

5. WHAT FUTURE ACCELERATED TESTING PROGRAM WOULD BE BENEFICIAL TO RESOLVING WEAKNESSES

QUALITY ASSURANCE PROGRAM:

1. Quantify Acceleration Factors on Component Life Testing
 - Identify Components
 - Identify Factors
 - Identify Lubrication
2. Demonstrate Health Monitoring Techniques

RESEARCH & TECHNOLOGY PROGRAM:

1. Scanning Earth Sensors
2. Momentum/Reaction Wheels
3. Improve Instrumentation for Health Monitoring
4. Delayed Cycle Systems
5. Spinners
6. Slip Rings

The above presents the results of all discussed matters which are established via prioritization method. Emphasis was put on the establishment and development of verifiable accelerated testing techniques.

TABLE OF CONTENTS

SECTION	PAGE
PREFACE	iii
LIST OF FIGURES	ix
LIST OF TABLES	xi
1.0 INTRODUCTION	1-1
2.0 TECHNICAL BACKGROUND	2-1
2.1 Selection of Lubricants	2-1
2.1.1 Solid Lubricants	2-1
2.1.2 Liquid Lubricants	2-8
2.2 Rolling Contact Bearings	2-15
2.2.1 Ball Bearing Retainers	2-15
2.2.2 "Blocking" Problem in Ball Bearings	2-17
2.2.3 Major Challenges for Rolling Contact Bearings in Space	2-20
2.2.4 Past Experience with Accelerated Testing Methods	2-21
2.2.5 DMA Evaluations	2-23
2.2.6 Summary of Accomplishments and Needs	2-46
3.0 DEVELOPING AN ACCELERATED TESTING TECHNOLOGY ROAD MAP	3-1
3.1 Items of Work Needed for the Technology Road Map	3-3
3.1.1 Identification of Ball Bearing Computer Programs	3-3
3.1.2 Selection and Evaluation of Monitoring Sensors	3-4
3.1.3 Additional Tasks Required for Technology Road Map	3-7
4.0 CONSTRUCTION OF A DEMONSTRATION PROGRAM (TASK VII)	4-1
4.1 Diagnostics	4-1
4.2 Lubricant Supply	4-2
4.3 Retainer Materials	4-2
4.4 Evaporation Rates of Oils	4-2
4.5 Item of Work vs. Time Required	4-3
5.0 REFERENCES	5-1

PRECEDING PAGE BLANK NOT FILMED



LIST OF FIGURES

NUMBER		PAGE
2-1	Friction Coefficient of MoS ₂ Films Deposited by Various Techniques	2-3
2-2	Mean Torque of Solid Lubricant Ball Bearings Operating at Room Temperature and at Cryogenic Temperature	2-3
2-3	Mean Torque of Ball Bearings Operating in Vacuum	2-8
2-4	Bearing Race Conformity	2-19
2-5	Race Curvature Effects	2-19
2-6	Predicted Effect of Conformity on Bearing Stress and Friction	2-19
2-7	Measured Bearing Torque as a Function of Lubricant Viscosity for an R-6 Bearing at 480 rpm	2-21
2-8	Despin Mechanical Assembly	2-22
2-9	Accelerated Bearing Life Test Matrix	2-24
2-10	Effect of Temperature on Viscosity of Test Lubricants	2-26
2-11	Metallic Wear vs. Speed and Preload, Silicone Oil	2-27
2-12	Metallic Wear vs. Speed and Preload Hydrocarbon Oil with Lead Naphthenate	2-27
2-13	Bearing Life Regimes	2-28
2-14a	Film Thickness vs. Load	2-29
2-14b	Film Thickness vs. Shaft Speed	2-29
2-14c	Film Thickness vs. Contact Angle	2-30
2-14d	Film Thickness vs. Race Curvature	2-30
2-15	Schematics of Bearing Test Rig	2-34
2-16	Temperature Sensing Technique	2-42
3-1	Tribological Regimes	3-2
3-2	Circuit for Contact Resistance Measurements	3-5
3-3	Percent Contact vs. Speed for Different R _{cs}	3-6
3-4	Schematic of Instrumentation for Contact Resistance Measurements	3-6
3-5	Cage Friction Test Geometry	3-10
3-6	Tribological Regimes	3-10
3-7	The Two Domains in a Full Hydrodynamic Film	3-11
3-8	The Weights of Morphological and Hydrodynamic Components in Tribological Processes	3-12
3-9	Theoretical Values of Q ₂ and T ₁ in Starved Bearings	3-12
3-10	Power Loss as a Function of Degree of Starvation, D = 5.51 in.	3-13
3-11	Pressure Profile at Bearing Midplane for Various Degrees of Starvation	3-13
4-1	Cage-Friction Test Geometry	4-3

PRECEDING PAGE BLANK NOT FILLED

LIST OF TABLES

NUMBER		PAGE
2-1	Relative Performance of Solid Lubricant Candidates in Ball Bearings and Gears	2-5
2-2	Summary of Test Results	2-6
2-3	Oscillation Brush Commutator Test	2-9
2-4	Comparison of Solid vs. Lubrication	2-10
2-5	Surface Tension Values for Selected Lubricants	2-14
2-6	Why Rolling Contact Bearings	2-16
2-7	Corrective Actions to Decrease Blocking	2-18
2-8	Factors Tending to Increase Blocking	2-18
2-9	Possible Failure Modes of DMA Bearings	2-24
2-10	Test Bearing Description	2-28
2-11	Failure Modes of Rolling Element Bearings	2-31
2-12	Acceleration Factors	2-31
2-13	Test Data Summary	2-32
2-14	Description of Test Oils	2-35
2-15	Short-Term Exploratory Test Summary	2-37
2-16	Long-Term Endurance Test Summary	2-38
2-17	Test Summary	2-41
2-18	Description of Lubricants	2-42
2-19	Relative Characteristics of DMA Operational Parameters	2-44
3-1	Typical Sensors Used in the Laboratory	3-3
4-1	Estimated Man-Months and Material Costs to Complete the Demonstration Program	4-4

PRECEDING PAGE BLANK NOT FILMED

1.0 INTRODUCTION

The goal of building longer-life unmanned satellites and space probes has created a demand for meaningful accelerated test methods to simulate long term service in space. This is particularly true for tribological components such as bearings and gears. There is an urgent need for light-weight, low torque, durable mechanisms that can operate efficiently in a hard vacuum environment.

Most spacecraft have unique functional designs and mechanical requirements. Tight schedules and budgets make it practically impossible to life test them on the ground. The alternative is to develop test methods and instrumentation which would make it possible to condense years of service into months of ground testing. One or more operating variables such as: speed, temperature, lubricant depletion, etc., need to be selected to accelerate the tests. However, changes in these operating variables must not change the basic mode of failure that typifies the particular application. This, in turn, requires that the normal mode of failure be identified first. To be realistic, these ground tests must not only reflect physical conditions such as loads, speeds or temperatures, but must also simulate the environment, particularly the hard vacuum conditions, that will be encountered in space.

In response to this need for higher component reliability, a number of workshops have been held to search for ways that this problem could be approached. Lists of mechanisms that would benefit from accelerated tests have been drawn up. Typical examples are given in Tables 1-1 and 1-2. These lists illustrate the magnitude of the problem. Some well-placed efforts at this time could reduce the number of premature failures and avoid the need for unwanted compromises in design or function.

This report has been prepared to describe the types of instrumentation and test techniques that would be used to accomplish the goals of this work. In Section 2.0, a review of the literature on Tribology in space is presented. The purpose of this review is to identify some of the problems (and solutions) experienced with many of the components listed in Table 1a of the preceding section, and then to extend the findings to include the items required for Predictive Design, Table 1b.

One added bonus from the literature review in Section 2.0 was a broad brush look at the instrumentation that has been used for bearing and slip rings tests. Measurements of torque, motor current, temperatures and electrical contact resistance are typical. However, most of the instrumentation is rudimentary by present-day standards. Recent developments in semiconductor research, leading to the development of miniature sensor packages, must be explored. The ultimate goal here is to incorporate the sensors into the ground test equipment, and then into the satellite so that performance could continue to be monitored in space.

PRECEDING PAGE BLANK NOT FILMED

2.0 TECHNICAL BACKGROUND

The objective of this investigation is to identify techniques for performing accelerated tests on tribological components intended for space applications. From the outset, it should be noted that a number of decisions are necessary to generate meaningful test results. For example, the type of bearing, the bearing material combination, and its surface characteristics should be established as soon as possible. The test specimens should have, within reason, the same characteristics. The test conditions, (generally vacuum, load, contact temperature, sliding velocity, and cycle life) should then be reviewed. For rolling contact bearings, an analysis must be made to predict the EHD film thickness and the degree of slip. Once it has been decided which variable(s) would be used to accelerate the test, all the other variables must be kept constant. Any processing steps, such as cleaning procedures for the actual parts, must also be used to prepare the test specimens.

In this section, a review of the pertinent literature on bearings and lubricants for spacecraft is presented. This review is not intended to be a detailed coverage of the literature on space lubrication, but rather an effort to cite previous experience or experimental evidence which showed that the selection of particular materials or lubricants or the use of certain analytical procedures was beneficial in designing and building successful space vehicles. If a number of authors highlighted some material or process that proved to be very successful, then serious consideration should be given to the evaluation and use of the same material or process in whatever the current spacecraft application might be.

2.1 Selection of Lubricants

2.1.1 Solid Lubricants

A number of useful publications have been written on the use of solid lubricants for space applications. Realistically, the most likely candidates are in the following categories^[2]:

- Soft metal films - especially Pb, but also Ag and Au
- Lamellar solids - e.g., MoS₂ and WS₂
- Polymers - such as PTFE films and glass fiber reinforced composites

Many other candidates could also be considered, but these are the primary choices. The techniques for applying thin, adherent films have been worked out, their advantages and disadvantages are well established, and they have been "space proven" by years of service in laboratory vacuum chambers and in outer space. One early incentive for using soft metal films as lubricants for instrument size ball bearings was not space, but rather the rotating anode x-ray tube, which runs at high temperature in a vacuum. Promising results were obtained with barium and other metal films, vaporized on the surfaces of Circle C (18-4-1) tool steel ball bearings, and run at 3600 rpm in vacuum^[3].

Subsequent room temperature evaluations were made by NASA engineers^[4,5], using various soft metals to lubricate instrument size ball bearings, and running the bearings in vacuum at 10,000 rpm under a light radial load. Those test results indicated that Circle C tool steel, angular-contact rolling element bearings with machined cages of

silver-plated annealed tool steel, silver-plated raceways, and gold-plated balls were a good choice for long life. Why a tool steel bearing? Because it was the standard high temperature bearing used in the x-ray tubes; thus, it was readily available. Their results also indicated that softer retainer materials were less effective than the annealed tool steel. Other investigators have come to the same conclusion.

As the space program developed in the U.S., interest in soft metal films was redirected toward lamellar solids, especially MoS₂. (In addition, more emphasis was also placed on liquid lubricants because these were more familiar candidates. The liquid lubricants are discussed in the following section).

Early attempts to use MoS₂ and PTFE as low friction coatings met with limited success^[6,7]. They were suitable for lightly-loaded hinges, louver bearings, and other components that only needed to last for a limited number of cycles, but methods of application, which included burnishing, adhesive bonding, and high-velocity particle impingement, did not provide long-life coatings. Burnished or impinged material had low adhesion and durability. Bonded coatings were too thick. As soon as loose particles were generated in the bearing, the torque became higher and more erratic. In many instances, it was believed that the lubricant films were worn away during ground tests, prior to launch.

The development of sputtering techniques to deposit thin (>1μm) and adherent coatings of MoS₂ resolved most of these problems^[8,9]. These thin coatings provided low and consistent torque and long wear life in vacuum. Figure 2-1, which was taken from ^[10], shows the effects of application methods on the endurance of MoS₂ coatings.

Roberts^[14] found that sputtering MoS₂ on the ball bearing races and the retainer gave the lowest torque. For minimum friction, steel surfaces should have a finish of 0.1-0.15 μm CLA. The friction of smoother surfaces would be twice as high. Coating the balls, in addition to the raceways and retainer, roughly doubled the torque (although it was still very low). However, the wear life was extended by a factor of three. Use of a Duroid retainer (PTFE-glass fiber - MoS₂) increases the wear life even more.

In the European Space Agency (ESA), the decision was made, early on, to limit the use of the liquid lubricants to momentum wheels, gyroscopes, and similar applications, and to concentrate on soft metal films, especially lead films, as the lubricants for instrument bearings, gears, etc. They found that lead films, evaporated or electroplated on the bearing surfaces, gave very promising results^[6,11]. Later, the process was upgraded to the use of ion plating techniques to apply thin, adherent films. Like the sputtered MoS₂ films, the ion-plated lead coating is less than a micrometer thick, but remarkably durable. Figure 2-2 compares the torque of bearings lubricated by these coatings with the performance of a bearing having a composite retainer.

In order to maximize the performance of ball bearings that have a lead film as the lubricant, it has been found that a leaded-bronze machined retainer is important^[6,11]. The role of this retainer is not well understood. Compared to a full complement bearing (no retainer), the bearing with the bronze retainer has lower torque and less torque noise. However, it does not have as long a life. Tests have shown that the retainer transfers a film of bronze to the raceway tracks. Eventually, flakes of bronze wear particles are generated, and their buildup jams the bearing. There is no solid evidence to prove that the lead in the bronze is an important ingredient. Studies by Gerkema^[13] showed that copper enhanced the adhesion of lead to steel. This may be part of the reason why the bronze cage reduces the torque.

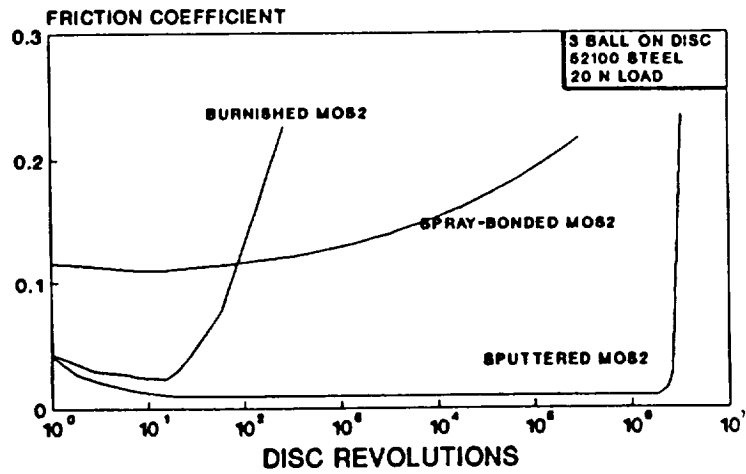

Figure 2-1. Friction Coefficient of MoS₂ Films Deposited by Various Techniques. From [10].

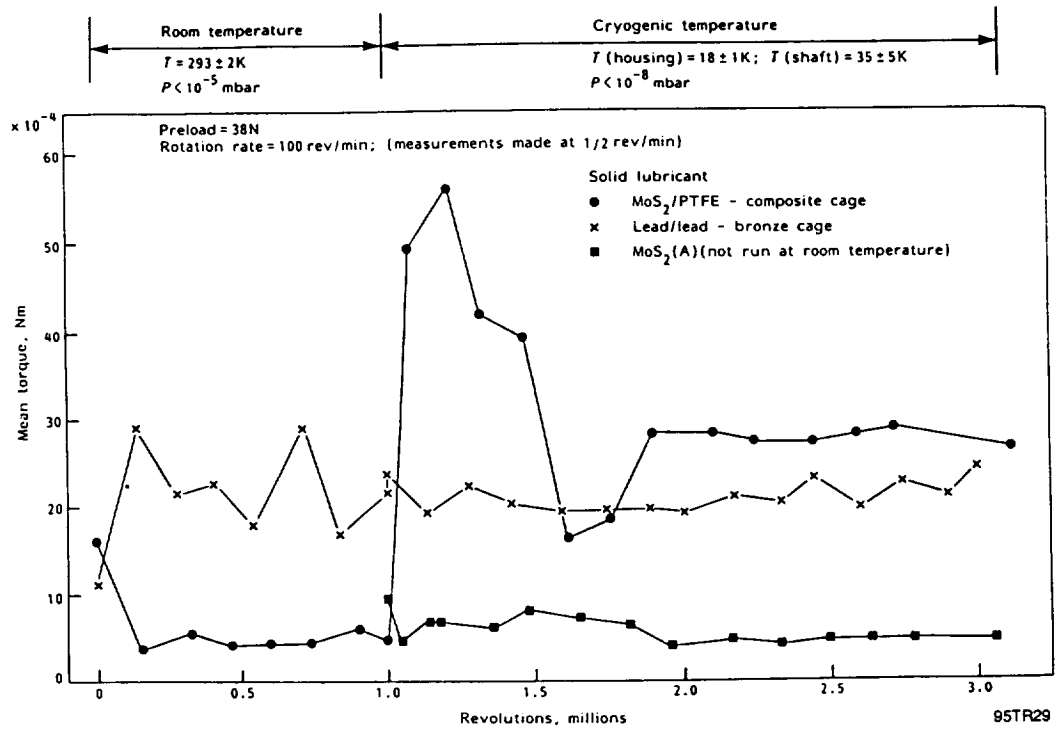

Figure 2-2. Mean Torque of Solid Lubricant Ball Bearings Operating at Room Temperature and at Cryogenic Temperature (in vacuo). From [14].

Each of these coatings has certain unique properties. In Table 2-1, an attempt has been made to rank them for particular characteristics which would be of concern to an engineering designer who needed a lubricant for a particular application.

Recent developments in the application of both MoS₂ and lead films^[12,13] have shown that optimizing the coating process can improve the wear life of these coatings many-fold. With MoS₂, it has also been found that when a thin, hard coating of a material such as TiC or TiN is applied on the substrate, and then the MoS₂ is used as the top coating, very low friction and high endurance is obtained^[7,14,15].

One major problem with MoS₂ and to a lesser extent with lead, is the possibility of a reaction with oxygen in the normal air environment, especially under humid conditions during ground tests. This can reduce the wear life of the lubricant coating by a factor of a hundred or more^[6,16], even in dry air. MoS₂ can oxidize and that will degrade both the friction and the wear life^[16]. Lead also appears to be sensitive to reaction with the environment, although this may be less of a problem. Todd^[2] reported that lead was only affected at speeds above 100 rpm. These reactions between the environment and the solid lubricant appear to be tribochemical in nature because they can be suppressed by reducing loads or speeds.

There is limited, and often conflicting information, on the use of gold as a solid lubricant in ball bearings. However, if the satellite must operate in a low earth orbit where atomic oxygen is a major constituent of the atmosphere, there would be a problem of oxidation if materials such as MoS₂, carbon, or silver were exposed to the outside environment^[14,17]. On the other hand, gold should be inert to the atomic oxygen and could be used as a soft metal lubricant for ball bearings or sliding electrical contacts under any conditions^[14]. Efforts should be made to optimize application techniques for gold and its alloys and to develop gold combinations for solid lubricant films.

In addition to the soft metal coatings and lamellar solid lubricants, the third category of solid lubricants includes composites based on polymer matrices such as PTFE, polyimides and acetals. Most of the experience has been gained with glass fiber-reinforced PTFE composites. These also contain 2-10% MoS₂, which is added to reduce transfer of the PTFE. This composite is used for ball bearing retainers and also as an idler gear to provide a lubricating film for spur gears. Early work on composite retainers was done in vacuum by Young, et al.^[18], Bowen^[19], and Harris, et al.^[6]. They found that effective performance was achieved with light radial loads. However, axially preloaded bearings showed severe wear and failed much sooner than the radially-loaded bearings.

Smith and Vest^[20] used PFM (59% PTFE, 39% fiberglass, and 2% MoS₂) in the form of crown retainers to lubricate ball bearings in vacuum. The bearings were first run-in, in air of 30% relative humidity, at 400 rpm for 30,000 revolutions, to coat the balls and races. Then they ran a duplex pair in vacuum at 2000 rpm with an axial preload of 560 grams. The bearings seized after 160 hours (19.2 x 10⁶ revs). Without the preload, the test ran at 3 x 10⁻⁷ torr for 6464 hours (7.8 x 10⁸ revs) before the test was stopped for inspection. The ball pockets were elongated and the torque had almost doubled, but the bearings were still functioning. They also tested the composite retainer in actuator bearings that had to oscillate over 90 deg. at 1 cpm. To accelerate this test, they increased the oscillation rate to 30 cpm. The bearings failed in 120,000 cycles due to wear particles in the retainer (this is equivalent to 7.5 years in orbit). Vest and Ward^[21] evaluated PFM retainers in bearings that oscillated at slow speeds and in slowly rotating bearings. The results are shown in Table 2-2.

Table 2-1. Relative Performance of Solid Lubricant Candidates in Ball Bearings and Gears.

APPLICATION	ION-PLATED LEAD	SPUTTERED MoS ₂	PTFE COMPOSITE
Flanking of lubricant life	Best in rolling contacts	Second best. Failures are rather sudden	Wear debris can cause jamming
Ball bearing run in air	Large decrease in life	Large decrease in life	Effective in air (transfer film)
Ball bearing run in vacuum	Outstanding life under mild conditions	Very good life under mild conditions	Good life under mild conditions
Ball bearing load-carrying capacity	Best	Good	Limited critical stress
Ball bearing torque levels	Fairly good, but does tend to be unsteady	Very good, best with coated raceways and uncoated balls	Similar to lead
Torque noise	Moderate ^(a)	Very good, same note as above	Poorest, but still useful
Ball bearing wear	No wear of steel races when leaded bronze cage is used, just transfer	Fine steel wear debris, fine roughening	Above critical load, it will permit steel to wear
Effect of low temperature	Reported to be same as room temperature	Same as lead	Increased torque at cryogenic temperatures
Effect of dwell time	No effect for dwell times up to 1 week	Noticeable increase in friction until it runs in again ^(b)	Not reported in literature
Effect of substrate	Tool steel is very good in vacuum. 52100 steel (EN31) does not seem to be as effective ^(a) . Applying hard coatings such as TiN or TiC should resolve the problem.		
Rolling/sliding such as gears	Has been used successfully	Used more often, lower torque than lead	Used as idler gear to transfer lubricant to gear teeth
Sliding components	Not widely used, moderately effective	Very good especially for precision components	Good for bushings, guides, etc.

95TR29

^(a)After first million cycles (initially low)

^(b)After being stationary for a few minutes

Table 2-2. Summary of Test Results.

A. OSCILLATORY AND SLOW SPEED BALL BEARING ROTATION USING FIBERGLASS REINFORCED PTFE-MoS₂ RETAINERS (FROM⁽²⁾)

TEST	LUBRICANT MATERIAL	BEARING SIZE	RADIAL LOAD	SPEED RPM	ARC OF TRAVEL	TOTAL CYCLES	CONDITION AFTER TEST
1. Oscillating Bearings	PTFE & MoS ₂	R-6	1 1/2 lb	+ 1/3, -10	±50°	1 x 10 ⁶	Excellent
	MoS ₂ Powder	R-1	1 lb	10	Full Circular	5 x 10 ⁶	Good
2. Oscillating Tachometer 3 Slow Speeds Dither	PTFE-MoS ₂	R-4	--	±<1 ±47	±80 ±7	7.9 x 10 ⁴ 5.6 x 10 ⁷	Good
	PTFE-MoS ₂	B542	1 1/2 lb	100	Full Circular	7.6 x 10 ⁷	Fair
3. Slow Speed	PTFE-MoS ₂	R-4	5 lb	100	Same	7.6 x 10 ⁷	Poor

95TR29

Todd^[2] and Stevens and Todd^[22] did extensive work with these composites as ball bearing retainers to determine optimum conditions and limits on performance.

Rowntree and Todd^[23] discussed the possibility of using a PTFE composite retainer in conjunction with a thin lubricant film applied to the surfaces of a ball bearing. The results, shown in Figure 2-3, were very promising, especially since a 40 N axial preload was used. They emphasized the fact that when the PTFE composite retainer is used, the maximum Hertzian contact stress must be kept below 1200 MPa at room temperature. Stresses above this level will degrade the transferred film of PTFE.

Solid Lubricants for Gears

Gears have also been the subject of solid lubricant studies in vacuum^[6,18,19,24,25]. Thin films of MoS₂ or lead have been shown to be effective lubricants for the contacting surfaces, but the wear life is limited. MoS₂ is preferred because it produces less torque. Composite idler gears can also be used to supply lubricant as it is worn away^[19,24]. Spur-type instrument gears were used in the work described in^[24]. These were type 303 stainless (passivated) and 2024T42 aluminum hard-coated (0.002" thick).

Plastic gears running against metals and against other plastics are providing excellent life at light loads, much better than metals. Suitable plastics include:

- Delrin (acetal) + 25% carbon fiber
- PTFE + glass fiber + MoS₂
- Nylon 66 + 25% carbon fiber
- Delrin versus Nylatron GS

Fusaro^[26] presented a detailed summary of the state of the art on polymers for use in space, with particular emphasis on the polyimides. He cited work by Briscoe and Todd^[27] which indicated that the maximum load that is used for plastic gears running against metals should be limited to 10 N mm⁻¹ tooth width.

There are times when it is necessary to run the gear teeth with no lubricant. For short periods of time, Auer^[28] was able to accomplish this by ion nitriding the gears. Hard, thin coatings of TiC or TiN would also be suitable.

Slip Rings and Roll Rings

Slip rings and other current-carrying devices for both power and signal transmission are a major source of concern with satellites and spacecraft^[25,29,30]. Electrical noise, caused by surface contaminants or corrosion products, can jeopardize the objective of the mission. For slip rings used in space, most of the brushes are made of composites of silver-molybdenum disulfide-carbon^[25,28,30].

A test program with Ball Brothers, INTELSAT, and Polyscientific (Litton Industries) participating showed that the composition of the optimum brush material in these tests was: 85 Ag, 12 MoS₂, 3 graphite^[30]. Auer^[28] described a "graded" brush fabricated by P/M which contained Ag and MoS₂. The soldered end of the brush had a high silver content, while the sliding end was higher in MoS₂.

To minimize electrical noise and excessive wear, these brushes should be protected from oxidation and corrosion due to humidity. Coin silver (Ag-Cu) or similar silver alloys are used for the rings. For low current densities, hard gold wire contacts about 0.015" in diameter were slid against soft gold rings which had a flash plating of hard gold^[30].

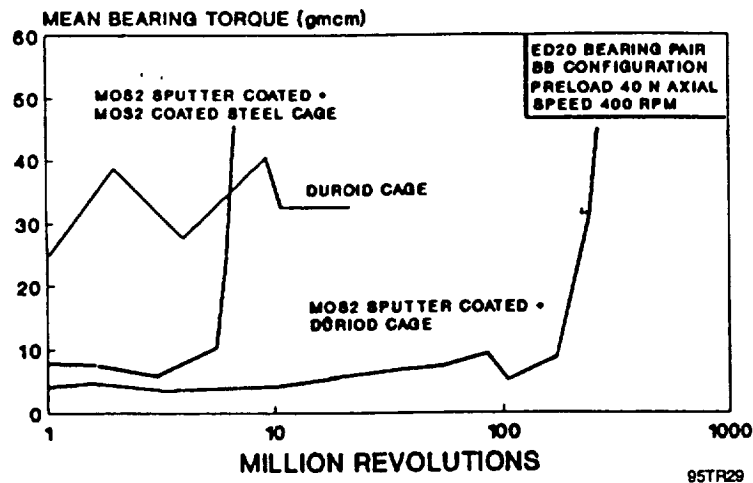

Figure 2-3. Mean Torque of Ball Bearings Operating in Vacuum. From ^[22].

The rings were V-grooved to maintain the lateral position of the wire contacts. This also provided a place for wear debris to get out of the contact area.

Smith^[31] described work which is in progress on roll rings as replacements for slip rings. These roll rings have been under development since about 1975. Their configuration is essentially one or more circular flexures (rings) captured by their own spring force in the annular space between two concentric conductors or contact rings. These inner and outer contact rings are rigidly mounted to the rotating and fixed sides, respectively, of the rotating axis. The advantages claimed for roll rings include: extremely low drag torque, high power transfer efficiencies, little wear debris, long life, and low weight, even for high power usage. However, no data comparing roll rings with slip rings are available.

Devine^[32] evaluated rolling element slip rings for vacuum use. Encouraging results were obtained, but this approach does not seem likely to replace slip rings which produce less noise.

Vest and Ward^[21] also performed some oscillatory tachometer tests to evaluate the effectiveness of burnished MoS₂ powder and gold inlays as lubricants for a brush-commutator. The alloy A brush was (35Pd, 10Pt, 30 Ag, 15 Cu, 10 Au, wt. %) the B alloy was (75 Au, 22 Ag, 3Ni, wt. %). The commutator was copper, and the MoS₂ and gold were applied to the surface of the commutator. A burnished film of MoS₂ was successful in minimizing noise. Test results are shown in Table 2-3.

2.1.2 Liquid Lubricants

Table 2-4 weighs the advantages of solid and liquid lubricants.

There are recent publications in the literature which have summed up the status of liquid lubricants for use in space ^[e.g., 33,34]. Therefore, this section will treat the subject in a more general fashion.

During the early years of the space program in the U.S., considerable emphasis was placed on the use of liquids as lubricants in satellites. The use of oils and greases, rather than solid lubricants, was considered to be a logical approach since a liquid lubricant could flow back or be resupplied to the contact area, while the effective life of a typical bonded solid lubricant film, which was available at that time, was often times much too short. Long life in high duty cycle applications was and still is the ultimate goal of this approach.

Table 2-3. Oscillation Brush Commutator¹ Test. From [20].

BRUSH TYPE	MATERIAL	CONTACT PRESSURE	LUBRICANT	TOTAL HOURS	OBSERVED WEAR	REMARKS
1. Leaf	alloy A	12 GM	MoS ₂ powder	3064	minimal	
	same	10 GM	same	2812	same	
	same	13 GM	18 K gold inlay	3064	same	noisy at 0.50°/sec
	same	14 GM	same	1389	same	noisy at 0.50°/sec
2. Button	alloy B	-	MoS ₂ powder	2812	same	
	same	10 GM	18 K gold inlay	1250	same	noisy at 0.50°/sec

95TR29

¹All Commutators were copper

Table 2-4. Comparison of Solid vs. Lubrication.

SOLID	LIQUID
Generally very low vapor pressure	Finite vapor pressure leading to oil evaporation and possible contamination of sensitive surfaces
Wide operating temperature range for most solid lubricants	Pour point, viscosity and high temperature volatility all temperature dependent
Potential surface contamination controllable (debris can float freely)	Seals required for prevention of contamination by creep or migration
May be oxidized by tests in air giving short life	Not very sensitive to air or vacuum at ambient temperature
Debris can cause frictional noise	Low frictional noise
Friction not very sensitive to speed	Bulk viscosity and viscosity-temperature properties will affect friction
Effective life determined by lubricant film wear	Life determined by loss of lubricant or frictional polymerization
Poor thermal conductor	Reasonably good thermal conductance
Some compounds are electrically conductive	Electrically insulating

95TR29

The major concern with liquid lubricants was the possible extent of evaporative losses. For this reason, the criteria for selection emphasized the need for low vapor pressure fluids, coupled with a wide useful temperature range. In the early days of space flight, a number of fluids were regarded as potential candidates^[35].

These included:

- The Apiezon oils - molecularly distilled petroleum oils
- Petroleum bright stock
- Super-refined petroleum oils
- Synthetic esters
- Various silicone fluids - polydimethyl siloxanes, methylphenyl siloxanes, and chlorophenylmethyl siloxanes
- Greases based on the above fluids, especially lithium soap-thickened chlorophenylmethyl siloxane (Tradenamed G-300)

Some of these fluids proved to be reasonably effective. Others, in particular the silicone oils, were rejected because they lacked the ability to provide effective boundary lubrication for steel surfaces. The chlorophenylmethyl silicones seemed to be an exception. The chlorine atoms that were attached to the phenyl groups were able to react with steel to form iron chloride (FeCl_2) which is an effective boundary lubricant. However, the formation of a rust-colored, gritty, polymeric residue was observed on many bearings as a result of the use of this oil. In the discussion of the perfluoropolyalkylethers (PFPE), which is presented later in this section, it is noted that iron chloride (FeCl_2) and iron fluoride (FeF_2) are Lewis acids which can probably catalyze the breakdown of both the silicone and the PFPE polymers to form solid degradation products.

Promising results were obtained in vacuum with most of the candidate petroleum oils and the esters. This was substantiated by Young et al.^[18] and by Harris and Warwick^[6]. The effective use of the petroleum oils in space was the ultimate proof. Now, thirty years later, the present list of candidate fluids for space is as follows:

- Apiezon oils - where the pour point is not a problem
- Super-refined petroleum oils - available in a range of viscosities
- Polyalphaolefins (PAO) - synthetic hydrocarbons. Properties can be varied by changing structure
- Polyolesters (POE) - synthetic polyesters (e.g., neopentyl ester)
- Perfluoropolyalkylethers
- Silahydrocarbons

The big advantage of the synthetic oils, especially PAO and POE, is that these fluids can be synthesized to form liquids with varying physical properties, which are very similar to petroleum oils. They are commercially available, and are reasonably good lubricants. Additives to inhibit oxidation, improve boundary lubrication, and provide rust prevention are available. However, there is a need to synthesize new additives with lower vapor pressures than the current materials. The base oils can be selected to be low vapor pressure liquids, but if the additives do not share this advantage, they would gradually be lost through evaporation.

Another class of fluids which show promise are the perfluoropolyalkyl ethers (PFPE). Certain fluids of this type have very low vapor pressures, low pour points, good viscosity-temperature characteristics and are very stable. Despite their high cost, they appeared to be very promising for use in space, but Carre^[36] hypothesized that under certain circumstances these oils could react with steel to form the Lewis acid FeF_3 which could catalyze cleavage of the PFPE to produce lower molecular weight reactive products and, ultimately, solid polymer debris. This series of events occurred with both 440C and 52100 steel ball bearings when the bearings were running on very thin EHD films with a significant percentage of metal to metal contacts. However, if one or both of the contacting surfaces had a hard coating, such as TiC or TiN, or if it was a solid ceramic, e.g., Si_3N_4 , then no reaction was detected.

In hindsight, similar reactions between the chlorinated phenylmethyl silicone and steel to form FeCl_3 probably account for the polymer formation observed with the silicone oil.

The perfluorinated oils are also used as lubricants for thin film magnetic recording discs. Strom et al.^[37] ran friction tests in high vacuum to determine what degradation products were formed. Their paper describes the results of running Al_2O_3 -TiC sliders on discs of Al-Mg coated with Ni-P and a 70 nm magnetic layer of Co-Pt-Ni covered with 30 nm of sputtered amorphous carbon. Both Fomblin-Z and Krytox 143AX were used as lubricants. With a mass spectrometer, they detected decomposition products such as CF_2 , HCF_2 , CF_3 , etc. Those authors concluded that catalytic activity of the slider or disc material was not a factor. Instead, they hypothesized that tribological activation through electron emission was responsible for the decomposition of the perfluorinated ethers. Mori and Morales^[38] found that PFPE oils of certain chemical structures decomposed when lubricating type 440C stainless specimens sliding in vacuum.

Sharma, et al.^[39] compared the lubricating characteristics of a paraffinic mineral oil, a polyalphaolefin synthetic hydrocarbon (PAO), a naphthenic mineral oil and a silahydrocarbon. In four-ball tests, higher wear was observed with the silahydrocarbon, but this was attributed to the fact that no lubricity additive was used in that oil. The other candidates gave essentially the same wear results. EHD traction experiments showed that the traction of the silahydrocarbon was lowest, the PAO fluid was intermediate, and the paraffinic oil had the highest traction values. While these synthetic oils show promise, much remains to be done to determine their qualifications for use in space.

Most of the current emphasis is on the fluid base stocks, but more thought should be given to the use of additives to enhance lubricity. Tricresyl phosphate (TCP) has been used for decades to improve the load-carrying capacity of petroleum oils. It is one ingredient in the additive package used by the Navy for turbine oil applications [MIL-L-17331D(Ships)]. During the 1950's, it was adopted as a lubricity additive for ball bearing guidance gyroscopes. Lead naphthenate was, and still is, being used very effectively as a lubricant additive by the Ball Aerospace Systems Division. There is good reason to use these antiwear additives as insurance against wear problems.

Other additives also seem to offer promise in enhancing EHD effects. Research workers at Imperial College in London have described the formation and growth of thick chemical films in EHD contacts when phosphonate esters are used as additives^[40,41]. To an engineer, faced with the problem that many ball bearings in space are running at such low speeds that EHD effects are minimal, every little bit helps.

Greases

In the early 1960's, a lithium soap-thickened silicone oil based grease, trade-name G-300, was widely regarded as a promising lubricant for use in space^[42]. The base oil for this grease was a chlorophenylmethyl silicone. While the volatility of the silicone was reasonably low, it wet metal surfaces readily and, because of its low surface tension, it migrated away from the area where lubrication was required. This, coupled with the fact that the grease often formed a gritty polymeric residue in bearings, discouraged use of the G-300.

In England, during the 1970's, a super-refined petroleum oil, BP-110, with a vapor pressure below 4×10^{-8} torr at room temperature, was developed^[27]. This product was also available as a grease thickened with an oleophilic graphite-lead composite. Both the oil and the grease went through all of the ground qualification tests successfully. However, the supplier withdrew the product because the market was too limited. This is a familiar problem with space mechanisms. Quantities are so small in number that manufacturers are reluctant to qualify products to rigid specifications.

Braycote 601 is a grease which has Bray 815Z as a base oil and a fluorocarbon telomer as a thickener. Purdy^[43] evaluated this grease in a bronze vs. steel worm gear drive. It was not effective in cold vacuum testing because of lubricant depletion. The problem was solved by switching to Bray 608, which has a high oil content and contains an MoS₂ powder dispersed in the grease. Worm gears experience a high percentage of sliding contacts and benefit greatly from the use of colloidal MoS₂ dispersed in oil or grease. Pacholke and Marshek^[44] evaluated the performance of these units by dynamometer tests and showed that the use of 1% colloidal MoS₂ dispersed in a synthetic hydrocarbon (PAO fluid) resulted in a significant improvement in efficiency and also ran with a lower sump temperature.

Wetting and Migration of Fluids

In addition to the loss of lubricant by evaporation, there is a tendency for fluids to wet and spread across adjacent high energy surfaces. This not only reduces the amount of fluid available for lubrication, it also increases the exposed surface area of the fluid, thus promoting faster evaporation.

When a drop of oil is placed on a solid surface, its behavior depends on whether the attractive forces of the liquid molecules are stronger for each other than they are for the surface of the solid. The surface tension of the liquid is one measure of these forces. If the liquid has a low surface tension, it will wet and spread over a high energy surface, such as a metal or a ceramic. If the surface tension is higher than the energy of the solid surface, the liquid will tend to "bead up" on the surface like drops of water on the hood of a freshly waxed car. The wetting and spreading characteristics of a lubricant are influenced by a number of variables and are affected by traces of impurities. Table 2-5 lists some values of surface tension for lubricants that are candidates for use in space.

To add to the complexity of this wetting problem, there are polar liquids that will wet a solid surface and then recede. Hare and Zisman^[45] showed that the "autophobic" property of such liquids is caused by the adsorption of an oriented monolayer on the bare surface. When the resulting surface has a critical surface tension that is below the surface tension of the liquid, the liquid withdraws, leaving the surface with only the adsorbed monolayer. This phenomenon is a manifestation of the "Marangoni Effect"^[46], which describes the movement in fluid interfaces caused by local variations in interfacial tension due to changes in composition or temperature.

Table 2-5. Surface Tension Values for Selected Lubricants.

Perfluorinated polyalkylethers (PFPE)	19-22 dynes/cm.
Apiezon C	33
KG-80	33
SRG-10	28-30
Silicone oils	20-22
Polyalphaolefins (PAO)	-32 (estimated from structure)

95TR29

Packaging lubricated metal components in plastic which contains antistatic agents can also result in making the metal surfaces non-wetting^[47,48]. The antistatic agents are generally long-chain, surface active agents that can eliminate electrostatic charging by conducting the charge away. However, these antistatic compounds can also interact with either the lubricant or the metal surfaces, or both. They may cause the oil to thicken to a grease-like consistency, or the metal surface to become non-wetting. This can be a very critical problem and may be responsible for many instances of lubricant starvation.

This is not an academic problem, Benzing and Strang^[49] described the examination of test bearings where a number of balls were found to be non-wetted after they had been operating in vacuum for long periods of time. Running them in air for several hours restored the oil film. This behavior has been attributed to free phenol that was present in the laminated phenolic retainer and had contaminated the ball surfaces. It could also be related to the presence of adsorbed films of water on the bearing steel surfaces which were able to form hydrogen bonds with the adsorbed layer. When these films were exposed to vacuum for a long period of time, they could have been desorbed.

Other factors can also influence the wetting and spreading behavior of the oil. For example, surface temperature also plays a role in the movements of oil films on the bearing surfaces. Kannel and Dufrane^[50] noted this effect in their discussion of rolling contact bearings in space. Surface finish also influences the distribution of oil in the contact areas. The ball finishes are smooth enough so that they will have minimal effect, but the races generally have a characteristic orientation of machining grooves that can have a significant effect on oil distribution.

Holzhauser, et al.^[51] demonstrated in a lubricated SEM study that the flow of oil in a sliding contact was channelled by scratches or grooves in the metal surfaces. Low speed, steel-on-steel sliding experiments were run in situ in the SEM using a pin-on-cylinder geometry with a thin film of low vapor pressure hydrocarbon oil (Apiezon C) as the lubricant. With periodic videotaping of the lubricated sliding contact and surface topography measurements, the wear process was observed and documented from initial sliding on new material, through run-in, to the eventual failure of the contacts. Surface smoothing and agglomeration of wear debris interspersed with oil were observed during run-in. With further sliding, lubricant retaining grooves and scratches are lost as a result of the reduction in surface roughness. For softer steels, the smoothing process involves the filling in of grooves and finishing marks with plastically deformed metal, while the grooves on harder steel surfaces are lost as higher topographical features wear away. While the smoothing action takes place, debris/oil agglomerates are deposited along the sides of the wear track, leading to a further reduction in the lubricant that is available to the sliding contact.

Insufficient lubrication results in failure of the sliding surfaces. The failure mechanisms involve abrasive cutting for the softer steels and localized adhesion and plowing for the harder steels. In both cases, severe surface damage is observed.

Techniques have been developed to minimize the loss of lubricant because of evaporation or by wetting and migration. Close clearance labyrinth seals can be used to reduce evaporative losses to space^[52]. Migration can be prevented by the use of fluorocarbon barrier films^[53]. However, a number of commercial barrier films are available, and it is recommended that evaluation tests be run with the same barrier film material that is going to be used in the application. The same lubricant and the same surface preparation methods should also be used.

2.2 Rolling Contact Bearings

The rolling contact bearing is an essential part of the overall scheme of designing mechanical systems for space. Whether the need is for a bearing to oscillate or rotate slowly, or to run at higher speeds in a gyroscope or a momentum wheel, this type of bearing offers several unique advantages. Some of these are listed in Table 2-6.

Because these bearings will be operating in a weightless environment, applications where stiffness or positional accuracy are essential will require angular contact bearings that can be axially preloaded against each other by springs or by other means.

The bearing balls and races are generally made of type 440C martensitic stainless steel (16-18 chrome, 0.95-1.2 carbon, 0.75 Mo) or 52100 steel (1.25 chrome, 0.95-1.1 carbon). Hybrid bearings, with steel races and silicon nitride balls, are also being used successfully in a number of applications.

2.2.1 Ball Bearing Retainers

To separate and space the balls, retainers (cages) are used. It has been shown that full complement bearings (no retainer) often have longer life capability^[54], but the balls can catch up and the bearing does not run as smoothly as a bearing with a retainer. Most of the bearings that are being used in spacecraft have laminated phenolic retainers. These composites are formed by winding cylindrical shapes on a mandrel, using cotton fabric, linen or paper, bonded with phenolic resin, to form the laminate. The resulting shape is then cured with heat and machined to final form.

During the past 50 years, there has been much controversy about the way that the phenolic behaves as a retainer. First, there is a question as to whether these materials will really act as lubricant reservoirs. They are porous (2-7%), and when they are vacuum impregnated with oil they are supposed to be a source of fresh lubricant for the bearing as excess oil is lost by evaporation or creep. Those who distrust the phenolic suggest that the retainer may be siphoning in the oil rather than releasing it. This thought is reinforced by the fact that it takes a long time, possibly a year or more under vacuum to saturate the phenolic with oil^[55]. Since impregnation of the phenolic is generally done by submerging the retainer in warm oil, under vacuum, for a short period of time, it will not be saturated when it is put in service. In fact, retainers in guidance gyroscopes are centrifuged after impregnation to be sure that there is no excess oil to affect the torque.

Table 2-6. Why Rolling Contact Bearings.

- Available in many sizes and cross sections
- Minimal lubricant supply needed
- Low driving torque required
- High load carrying capacity
- Accurate positional capability
- Wide temperature operating range (with solid lubricants)
- Wide speed range capability
- Many analytical programs available

95TR29

Second, many technical people believe that the processing chemicals used in the manufacture of these composites can interfere with subsequent use, especially in the wetting and spreading of oils^[49].

Other plastic retainers, such as porous sintered nylon and polyimides, have also been evaluated^[50,70]. They have a higher degree of porosity, on the order of 20%. However, their ability to supply oil has also been challenged.

At the present time, the laminated phenolic retainer is still the material of choice. It has several positive features including:

1. Low density - minimizes both low speed torque pulses which promote retainer instability, and high speed centrifugal forces.
2. Adequate strength - used for high speed ball bearings.
3. Adequate dimensional stability.
4. A long history of successful applications ^[e.g., 6,18,42].

In addition, it does absorb lubricants and it should release oil with any increase in temperature or stress. It is difficult to examine an oil impregnated phenolic retainer under the microscope because heat from the microscope lamp causes a pool of oil to bleed out of the retainer, even if it has been wiped dry. It would be interesting to study this with some good instrumentation to determine if the temperature change had a more positive effect on oil delivery than the capillary attraction of the phenolic had on oil retention.

Because of the types of ball bearings that will be used, and the kinds of service that these bearings will provide in space, there are some problems that must be addressed. In many instances, angular contact bearings will be needed because the weightless environment dictates that the bearings must be preloaded to maintain accurate positioning and to minimize slip during reversals (if oscillation is the working mode). As noted below, this type of bearing has an added component of slip because of the change in curvature across the raceway.

Another problem is retainer instability. Kannel and Dufrane^[50] described an investigation of the relationship between retainer stability and lubricant properties in despun antenna bearings. This has been summarized by Zaretsky^[33].

Instability is initiated by the retainer catching up with, and hitting, a ball. The ball slips and this generates a reactive force against the retainer. If slip occurs easily, which would be the case where the lubricant is a low viscosity liquid and the ball is supported on an EHD film,

the reaction force will be small and the retainer energy will be absorbed by shear losses in the lubricant film. With a high viscosity liquid, the ball slip will be minimal, there will be little retainer energy absorbed by the shear losses, and the retainer motion will be largely undamped. This will introduce a rapid secondary motion causing errors in positioning, producing noise, and resulting in erratic torque values. The problem is aggravated by the fact that the bearings are running at low speeds where only partial EHD films can be expected. The longer term result will be an elongation of the retainer pockets by wear, and the production of loose wear debris in the raceways.

Lubricant viscosity is a major parameter and it has been found^[50] that stability can be enhanced by reducing lubricant viscosity, using race-riding retainers, or increasing the lubricant supply to the bearing. The latter step would also result in an increase in torque unless the viscosity was simultaneously reduced.

Boesiger and Warner^[57] described their efforts to develop a retainer for a Control-Moment Gyroscope reaction wheel assembly that would be less liable to become unstable. Their picture of retainer instability starts with ball-retainer collisions in a bearing, occurring with progressively increasing force. The motion of the retainer converts from simple rotation to random motions as well as whirling type behavior. Friction or viscous drag of the lubricant is believed to be the source of energy to drive the retainer unstable. Polymerization of the lubricant would increase the viscous drag, while lubricant starvation could result in higher friction. The authors have designed a retainer, using the ADORE computer program, and are supplementing the results with experimental data. The final qualification studies were just beginning when their paper was written.

2.2.2 "Blocking" Problem in Ball Bearings

When rolling contact bearings are used in oscillating applications, they sometimes show a gradual degradation in torque, especially when the oscillation angles are large^[58,59]. This phenomenon can occur, regardless of whether the bearings are lubricated with liquids or with solid films. Todd^[60] described the problem as "blocking". Loewenthal^[61] referred to it as "Ball Speed Variation" (BSV). The problem arises from the fact that the balls in an angular contact bearing don't just roll, they also tend to spin about an axis normal to the Hertzian contact area, and this combination of motions tend to make the balls creep laterally (perpendicular to the direction of ball center travel). Thus, there will be a unidirectional change in contact angle, and a change in ball orbital velocity, with time. The gradual drift of the balls will ultimately produce ball/cage forces that increase bearing torque. Thermal gradients may accelerate the process. This phenomenon is discussed in detail in references^[58-61]. Tables 2-7 and 2-8 list many of the factors that are known to be significant.

Figure 2-4^[61] illustrates the significance of Ball/Race Conformity, Figure 2-5^[59] shows the effects of race curvature on bearing pair torque, and Figure 2-6^[61] shows the effect of conformity on bearing stress and friction. These findings demonstrate the importance of keeping the conformity as loose as possible without producing excessive contact stresses at liftoff.

Table 2-7. Corrective Actions to Decrease Blocking. From ⁽⁶⁰⁾.

• Reduce Misalignment
• Reduce Conformity of Ball to Raceway
• Include periods of continuous rotation or, at least, vary angle of oscillation
• Leave extra clearance in retainer and/or compliance

95TR29

Table 2-8. Factors Tending to Increase Blocking. From ⁽⁶¹⁾.

FACTOR INCREASED	EFFECT
• Conformity (tighter)	Increase Spin - Higher spin torque and drag
• Contact Angle	Increases Spin - Higher spin torque and drag
• One-piece Cage	Restricts Ball Speed Spacing - Increases cage "wind-up"
• Misalignment	Increases Ball Speed Variation - Increases "cage wind-up"
• Preload	Increases Traction Forces - Increases anomalous torque
• Friction Coefficient	Increases Traction Forces - Increases anomalous torque
• Contact Angle Variation	Increases Ball Speed Variation
• Ball Diameter Tolerance	Increases Ball Speed Variation
• Thrust vs. Radial Bearing	Thrust Bearing Has All Balls Loaded - No opportunity for ball spacing to readjust

95TR29

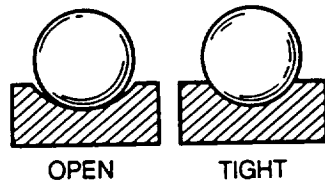

$$\text{CONFORMITY} = \frac{\text{RACE RADIUS}}{\text{BALL DIAMETER}}$$

95TR29

Figure 2-4. Bearing Race Conformity. From [59].

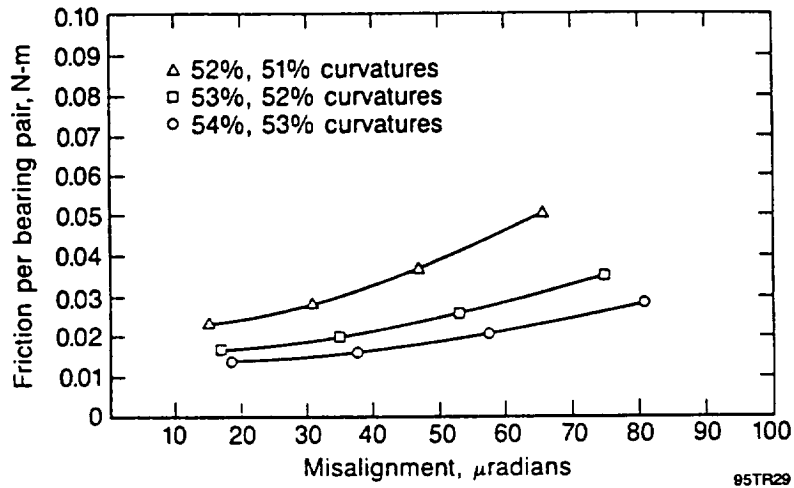

95TR29

Figure 2-5. Race Curvature Effects. From [59].

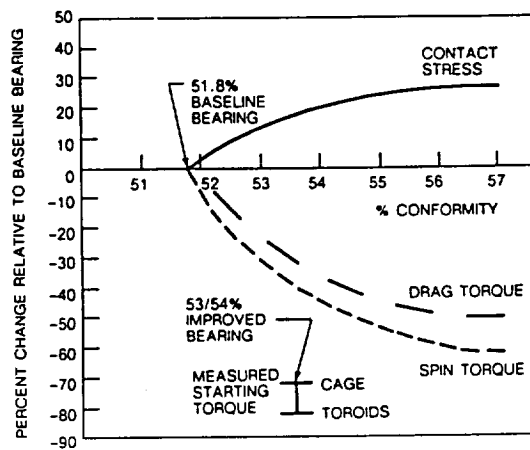

95TR29

Figure 2-6. Predicted Effect of Conformity on Bearing Stress and Friction. From [59].

2.2.3 Major Challenges for Rolling Contact Bearings in Space

At present, the two most urgent applications for ball bearings in space are the despin mechanical assembly (DMA) and the control-moment gyroscope (CMG). These are currently the major barriers to long-life satellites and spacecraft.

The despin assemblies generally operate in the speed range from 15 rpm to 100 rpm. Although space is a weightless environment, the bearings must be preloaded to satisfy the need for accurate positioning and pointing. Duplex pairs of angular contact bearings are used. The main problems with the ball bearings are lubricant loss by evaporation or migration, and the slow rotational speeds of the DMA. Ball bearings operate effectively when they are running on EHD films of oil even though the films are less than a fraction of a μm thick. At slow speeds, the EHD oil films are too thin to completely prevent metal to metal contact. Asperity contacts through the oil film can result in some frictional heating, some wear, and a gradual increase in torque. Couple these effects with a gradual loss of lubricant, and the possibility of retainer instability, and you have a barrier to long-life operation.

Control-Moment Gyroscopes used in spacecraft are large-scale gyros which, in contrast with those used as sensing instruments, must provide the essential "muscle" to maintain or correct the attitude of the whole spacecraft. Precessional output torques up to ten or even hundreds of foot-pounds must be supplied and, consequently, peak bearing loads are relatively high even in a zero "g" environment. The wheels operate at a constant speed although in some applications the speed is varied about some high average value to provide stabilizing torques about the spin axis as well as in the precessional directions. As the key attitude control element, momentum wheels must spin continuously during an entire mission. The reliability of their bearings must be high. Power input must be low. The prime mechanisms for making changes are these control-moment gyroscopes (CMG). Typically, three of these CMG's can be mounted in gimbals with their axes mutually perpendicular in the X, Y and Z directions. To maneuver, the axis of one or more of the control moment gyroscopes can be rotated by computer command. This causes a reactive force and rotation of the spacecraft in the desired direction. When the new attitude has been achieved, momentum is transferred back to the gyroscope, causing rotation to stop.

These gyroscopes and momentum wheels are not subjected to the hard vacuum of space. They are canned in chambers under a slight positive pressure of an inert gas. The reduced pressure minimizes windage losses. Super-refined gyroscope (SRG) mineral oils are commonly used as lubricants. These oils are available in a range of viscosities. Figure 2-7, taken from Kannel and Dufrane^[50], shows the effect of lubricant viscosity on bearing torque.

The lubrication problems here are concerned with the need for being able to provide just enough oil to maintain EHD films, but no more. It is important to note that, in the Skylab space station, there was a failure of one of the Control Moment Gyroscopes. The lubrication system was designed to supply oil to the bearings at a known small rate. The difficulties encountered suggest that something interrupted the lubricant delivery, perhaps retainer instability.

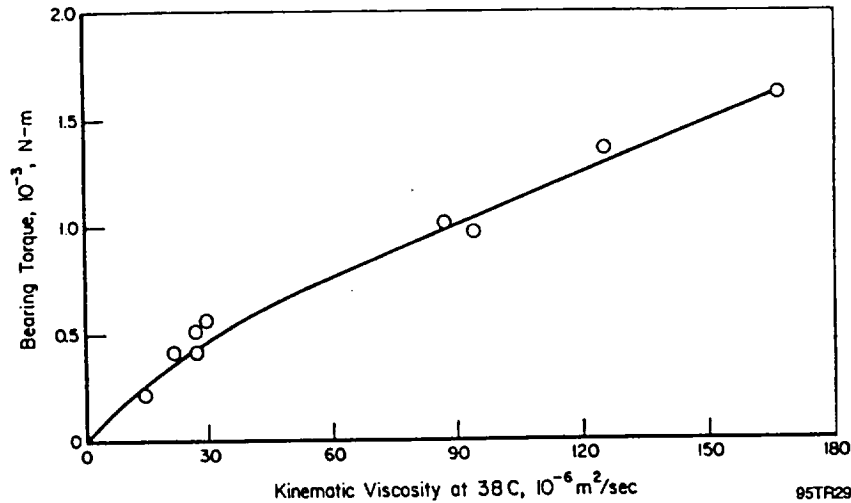

Figure 2-7. Measured Bearing Torque as a Function of Lubricant Viscosity for an R-6 Bearing at 480 rpm. From [50].

2.2.4 Past Experience With Accelerated Testing Methods

During the early 1960's, a number of research organizations [e.g., 6,18,24,25,56] did extensive bench testing in vacuum on small mechanical components such as instrument size ball bearings, slip rings and gears. The ball bearings were evaluated at speeds up to about 3000 rpm. The results showed that speed in this range had little effect on life as long as the bearings had some kind of a protective lubricant film, and frictional heating was not a problem. Low vapor pressure oils and greases, solid lubricants, and composite self-lubricating retainer materials all showed promise.

In contrast, load was definitely a limiting parameter, especially axial loads. The transition from an acceptable to a failure load was sudden. For example, Smith and Vest^[20] found that ball bearings with composite retainers failed after 160 hours in vacuum at 2000 rpm when the bearings had an axial preload of 5.6 N and a light radial load. After relieving the axial preload, a new set of bearings ran 6464 hours without failing. Christy^[7] found that raising the axial preload of a bearing from 1.11 N to 2.22 N decreased the life from 5000 to 100 hours. Radial loads were not as detrimental as axial loads, probably because of a higher percentage of rolling with a radial-loaded bearing.

Temperature is a difficult parameter to use for accelerating failures. The most obvious effect of temperature is to drive up the pressure in the vacuum chamber if liquid lubricants are being used, or if the test pieces are outgassing. With care, temperature can be used to adjust the viscosity of a liquid lubricant and thus simulate the performance of a lighter oil, but this requires very precise instrumentation to measure and control temperature. As shown in Figure 2-2 [14], temperature has little effect on the performance of solid lubricant films such as lead or MoS₂. These materials are effective, even at liquid helium temperatures. For minimum friction, MoS₂ is preferred.

In the late 60's and early 70's, emphasis shifted to larger rolling contact bearings for use in despun antennas and control moment gyroscopes. The despun mechanical assembly (DMA) is used on satellites that are spin-stabilized. It counteracts the rotation of the satellite so that the high gain antenna can always be pointed at a fixed position on earth for data transmission even though the satellite is constantly turning. Figure 2-8 taken from [49] is a sketch of the despin antenna drive system. The components that are of concern in this review are the ball bearings that permit rotation and the slip ring and brush assemblies that transfer signals.

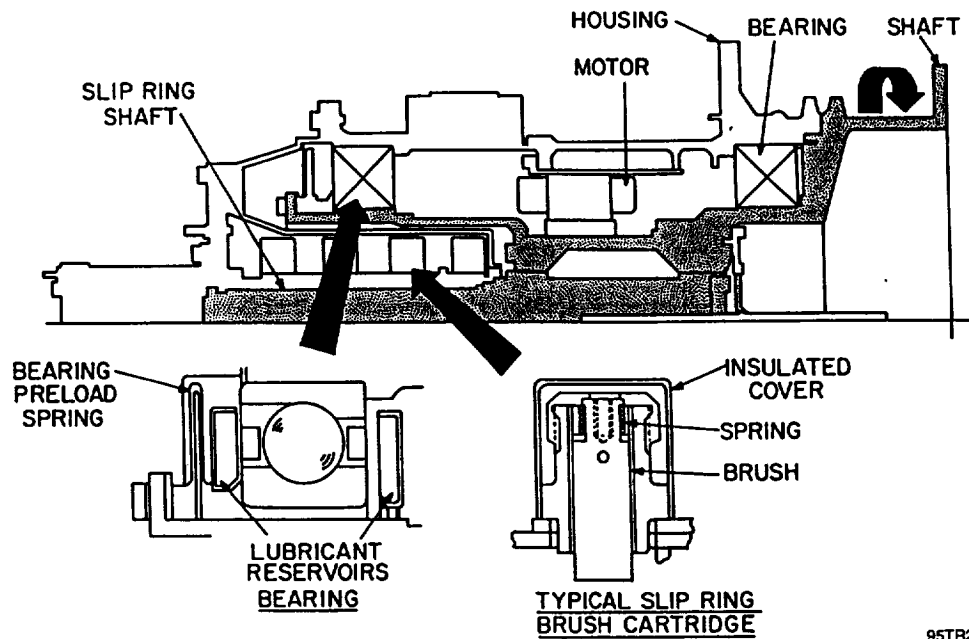

95TR29

Figure 2-8. Despin Mechanical Assembly (DMA). From ^[40].

A multi-year program was undertaken to identify and resolve bearing and lubrication problems that were obstacles to the development of new satellites. At that time, 2-4 years of unattended operation was feasible, but there were many failures. The new target for unattended life was 10-15 years, well beyond any available experience.

2.2.5 DMA Evaluations

On the following pages, brief summaries of the published work on the Despin Mechanical Assembly are presented.

The work was initiated by Benzing and Strang of the Air Force Materials Laboratory who prepared an exhaustive review of past experiences with satellites^[49]. They put major emphasis on the Despin Mechanical Assembly (DMA's) used on communication satellites. These assemblies were considered to be typical of the mechanical systems which posed the greatest problems in space hardware. Essentially, the assembly consists of a platform on which the high gain antenna is mounted. This antenna must be constantly aimed at a specific point on the earth. Since the satellite is spin stabilized, provision must be made to "despin" the antenna at the same counter-rotational speed. To accomplish this, the antenna is supported on a ball bearing mount which is attached to the platform. A motor rotates the antenna and a slip ring assembly which transmits signal data to orient the antenna. From the results of a number of anomalies and failures, these authors selected 12 failure modes, plus a miscellaneous category of incoming hardware which failed QC inspection. The failure modes are listed in Table 2-9. Most of the problems were related to a loss of lubricant from the contact areas or lubricant decomposition, although retainer instability and retainer wear also drew many comments.

The authors concluded that "A comprehensive and well-instrumented real time life test program is essential to the development of a rationale for meeting the DMA life and performance requirement".

At approximately the same time that the review described above was being done, Meeks^[62] was running an experimental study of DMA bearings. His goal was to develop a theoretically sound method for accelerating tests on bearings for space applications. He postulated that the factors leading to failure included:

1. Wear of balls, races or retainer
2. Loss of lubricant due to depletion or degradation
3. Fatigue failure
4. Chemical degradation due to polymerization or contamination

At that time, he was working on an actual bearing problem which involved a set of bearings operating in space for 3 years at 55 rpm and at an ambient temperature of 70°F. Each bearing had an axial preload of 20 pounds. Electrical contact resistance measurements showed that under these conditions the bearings would be running in the boundary lubrication regime. Therefore, in planning his experiments, he created a test matrix of loads and speeds that would bracket the application conditions. This matrix is shown in Figure 2-9. Two groups of bearings, with 18 bearings in each group, were evaluated. These were 440C bearings, with a typical, measured race finish of 0.8 to 2.0 μ in. The retainers were race-guided LBB grade cotton phenolic. The bearings were mounted as preloaded pairs, using wavy washers for loading. One group was lubricated with a chlorinated silicone oil, (Versilube F-50). The other group was lubricated

Table 2-9. Possible Failure Modes of DMA Bearings. From ^[40].

- | |
|------------------------------------|
| 1. Lubricant degradation |
| 2. Lubricant dewetting |
| 3. Slip ring and brush wear |
| 4. Improper lubricant transfer |
| 5. Inadequate lubricant quantity |
| 6. Lubricant volatility effects |
| 7. Lubricant incompatibility |
| 8. Torque variations |
| 9. Cage and bearing instability |
| 10. Cage wear |
| 11. Lubricant creep |
| 12. Film thickness |
| 13. Misc. effect - quality control |

95TR29

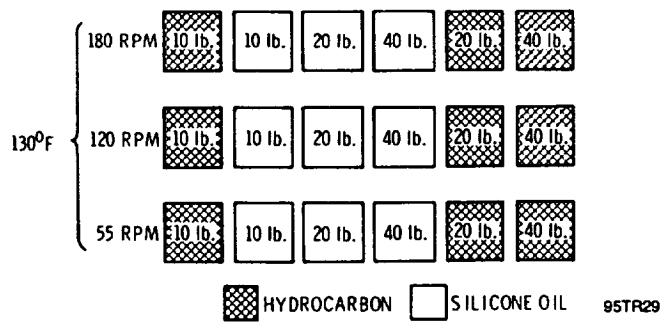

Figure 2-9. Accelerated Bearing Life Test Matrix. From ^[62].

with 95% petroleum oil + 5% lead naphthenate solution. As noted in the discussion, that oil had a viscosity of 51.4 cs at 130°F, essentially the same as Apiezon C. Figure 2-10 is a viscosity-temperature plot of the F-50 silicone and the Apiezon C petroleum oil.

The criterion for failure was a two-fold increase in running torque. To accelerate the tests, the author introduced an EHD film thickness equation from Harris^[63]. This equation showed that the EHD film thickness is a function of speed (N) and lubricant kinematic viscosity (ν). Thus, a bearing can be tested at speeds higher than the application by adjusting lubricant viscosity so that the product of speed (N) and viscosity (ν) remains constant. Viscosity could be decreased by raising the bearing test temperature. To illustrate, the viscosity of the silicone oil is reduced from about 70 to 30 cs when this oil is heated to 130°F (see Figure 2-10). This would allow the bearings to be run at 130°F and 120 rpm, while still maintaining the oil film thickness that would be present at 70°F and 55 rpm. This thickness was shown to be in the boundary lubrication regime by electrical resistance measurements.

Using this logic, an acceleration factor of about 2 was obtained while running at a temperature low enough so that the bearing materials would not be affected and no oxidation or degradation of the oil would occur. One group of silicone-lubricated bearings was run at 130°F and a speed of 180 rpm, which should be in the EHD regime. The second was run at 130°F and 120 rpm, bridging the gap between EHD and boundary lubrication. The third group was run at 130°F and 55 rpm, definitely boundary lubrication. Figure 2-11 shows the total amount of wear measured during the 7 month tests with the silicone oil.

The author stated that the petroleum oil-lubricated bearings were evaluated by the same procedure, with all tests being run at 130°F. The appearance of the oil did not indicate a problem, but the wear rate, plotted in Figure 2-12, seems higher than expected.

The author concluded that his work was just a beginning. Substantiating data from actual space hardware, as well as longer term ground tests were needed. The results obtained with the silicone oil do support data reported by other authors on the tendency of this oil to form solid polymers. The author also reported that the measured weight loss of the hydrocarbon oil exceeded predicted loss based on normal molecular flow. However, in the discussion of this paper, the author's closure noted that oil had not only evaporated and diffused out of the housing, but had also migrated out, despite the use of barrier films.

A second experimental study of failure modes and accelerated test methods for DMA bearings was reported by Smith and McGrew^[64]. The test bearings are described in Table 2-10. Figure 2-13 illustrates the range of specific film thicknesses over which the bearing life is optimized. Figures 2-14a to 2-14d show the calculated effects of thrust load, shaft speed, contact angle and race curvature factor on film thickness. Table 2-11 is a list of potential failure modes and Table 2-12 shows the acceleration factors that the authors considered. They emphasized the need to maintain the identical ratio of film thickness to surface roughness between test and application for complete similitude. Based on their review of the problem, they selected load speed, initial lubricant starvation, temperature and evaporation loss (by using condensing surfaces to trap escaping oil) as the major factors. Life tests were run in air and vacuum. In the vacuum tests, higher temperature, and acceleration of evaporation by using cold condensing surfaces, were the primary accelerating factors. Table 2-13 is a summary of the vacuum test results. The nature of the failures indicated that loss of lubricant was the most likely failure mode. Using a life algorithm, based on their results, the

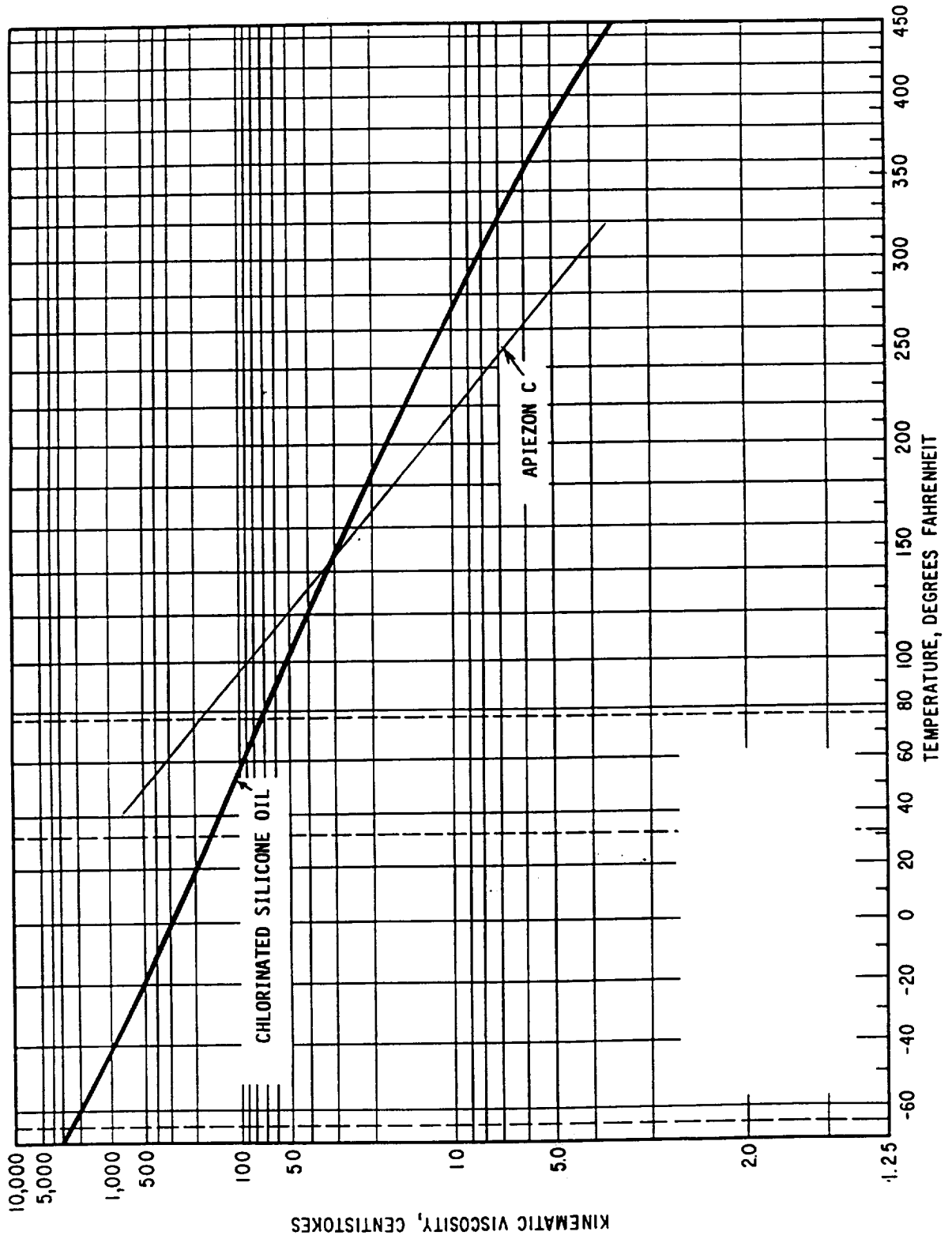

95TR29

Figure 2-10. Effect of Temperature on Viscosity of Test Lubricants.

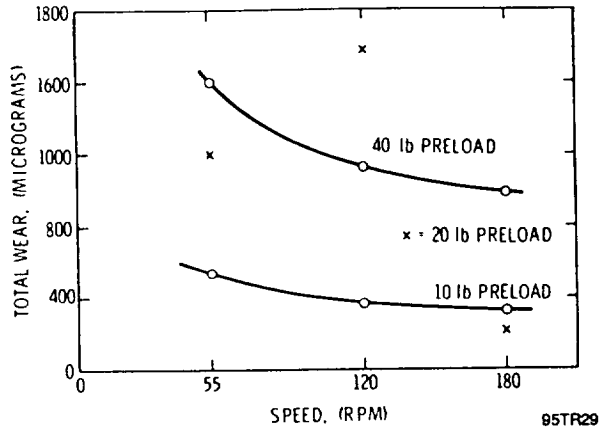

Figure 2-11. Metallic Wear vs. Speed and Preload, Silicone Oil. From [62].

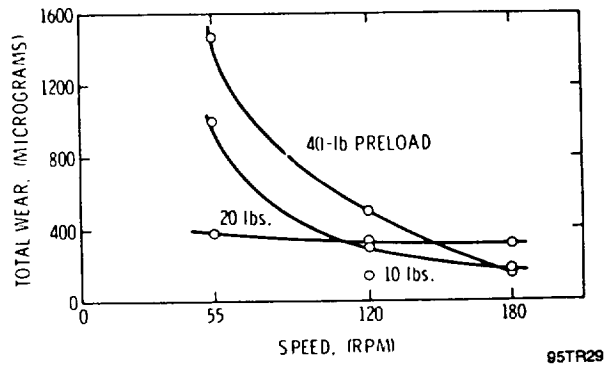
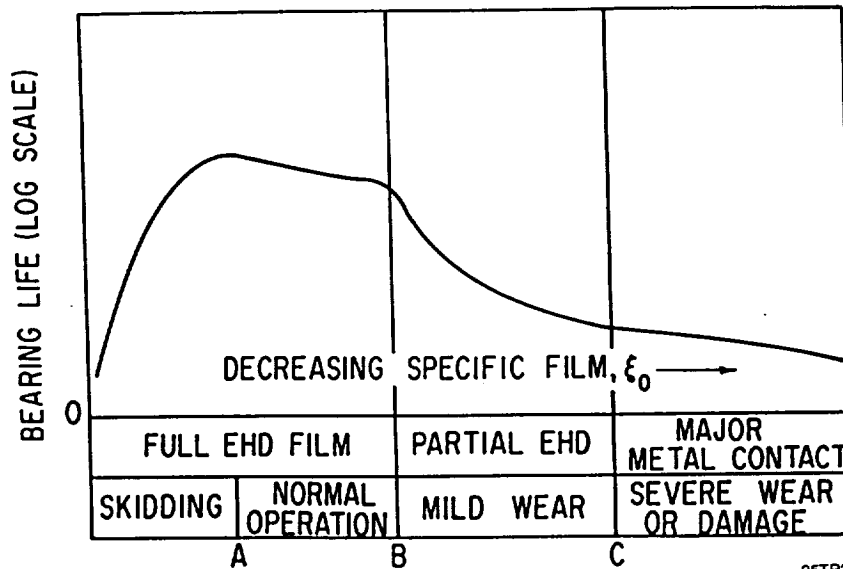

Figure 2-12. Metallic Wear vs. Speed and Preload Hydrocarbon Oil with Lead Naphthenate. From [64].

Table 2-10. Test Bearing Description. From [64].

	TEST BEARING A	TEST BEARING B
Type.....	MRC 7118KR Angular Contact Bearing	MRC 7118KR-ST Angular Contact Bearing
Bore.....	90 mm +0-0.00025	90 mm
OD.....	140 mm +0-0.0004	140 mm
Ball Number.....	21	16
Ball Diameter.....	0.5625	0.5625
Contact Angle.....	15° Nominal, 13.4°-18.4°	25°
Lubricant.....	Vac Kote Impregnated Phenolic Retainers	Vac Kote Impregnated Phenolic Retainers
Material.....	52100	440 C
Curvature.....	0.5850 ± 0.001	0.5850 ± 0.001
Tolerance.....	ABEC 7	ABEC 7
Retainer.....	Inner Race Guided	Inner Race Guided
Retainer Porosity.....	3-5%	3-5%
Retainer Volume.....	28 cc	32 cc
Average Takeup:		
Retainer.....	1.77 gms
Bearing Surface.....	0.44 gms	0.44 gms
Bearing Working Surface...	0.125 gms	0.111 gms
Nominal Film Thickness.....	300 microinches	300 microinches
Ball Area.....	21	16
Inner Race Area.....	39.86	40.81
Outer Race Area.....	40.81	39.86

95TR29



95TR29

Figure 2-13. Bearing Life Regimes. From [64].

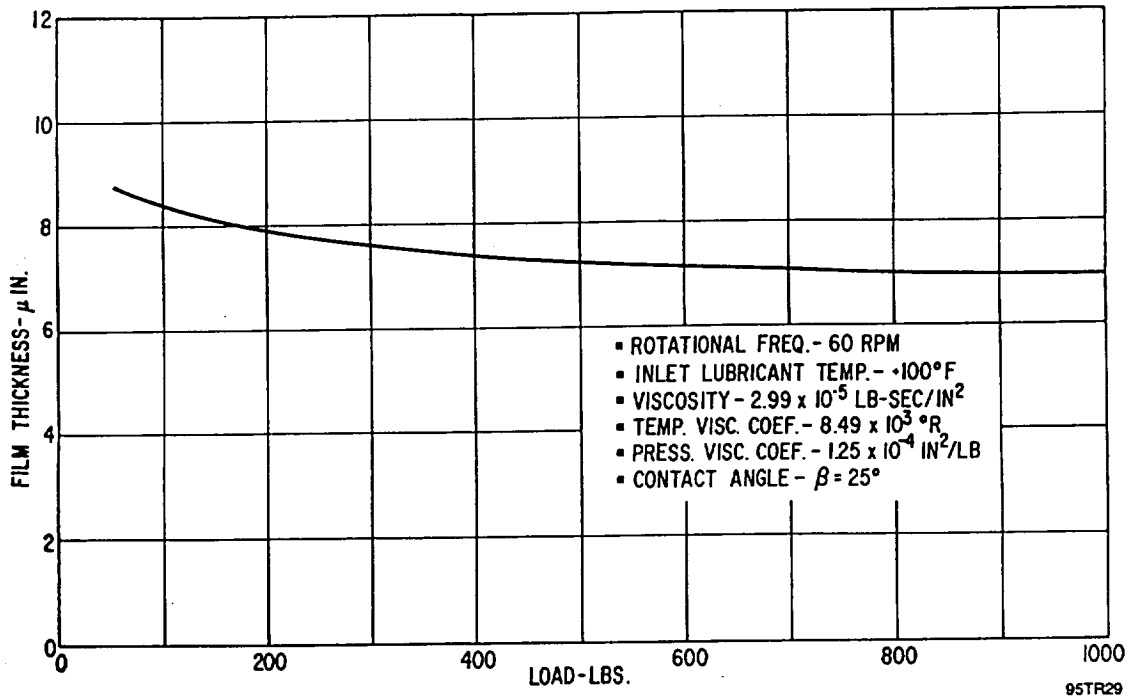

Figure 2-14a. Film Thickness vs. Load. From [64].

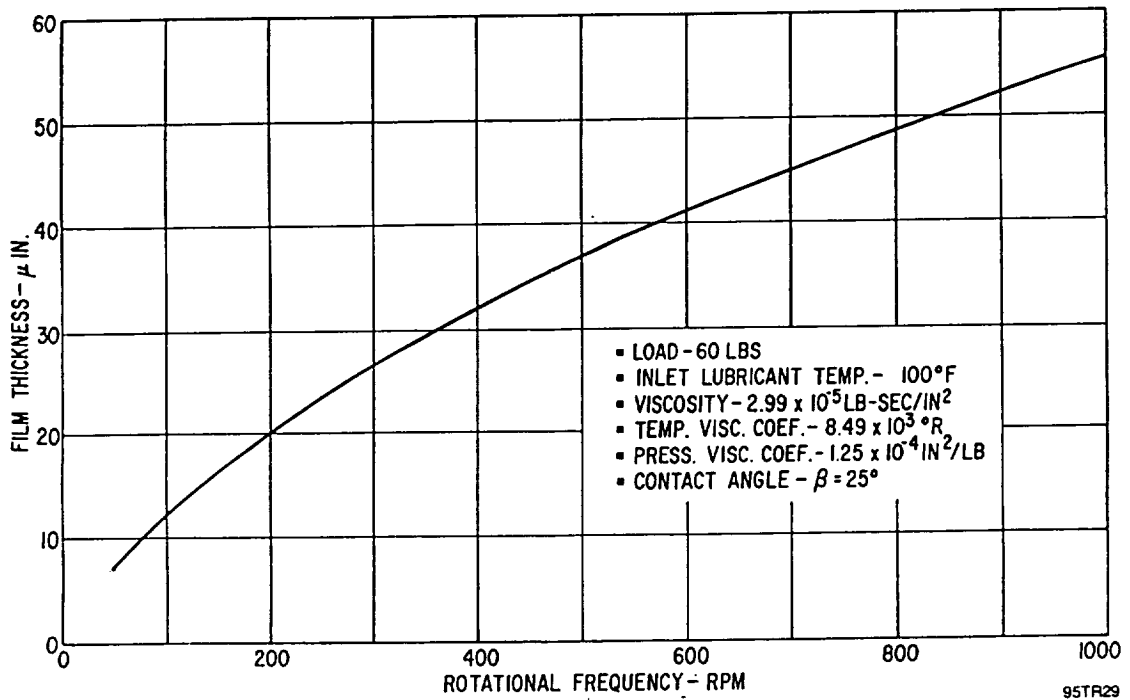

Figure 2-14b. Film Thickness vs. Shaft Speed. From [64].

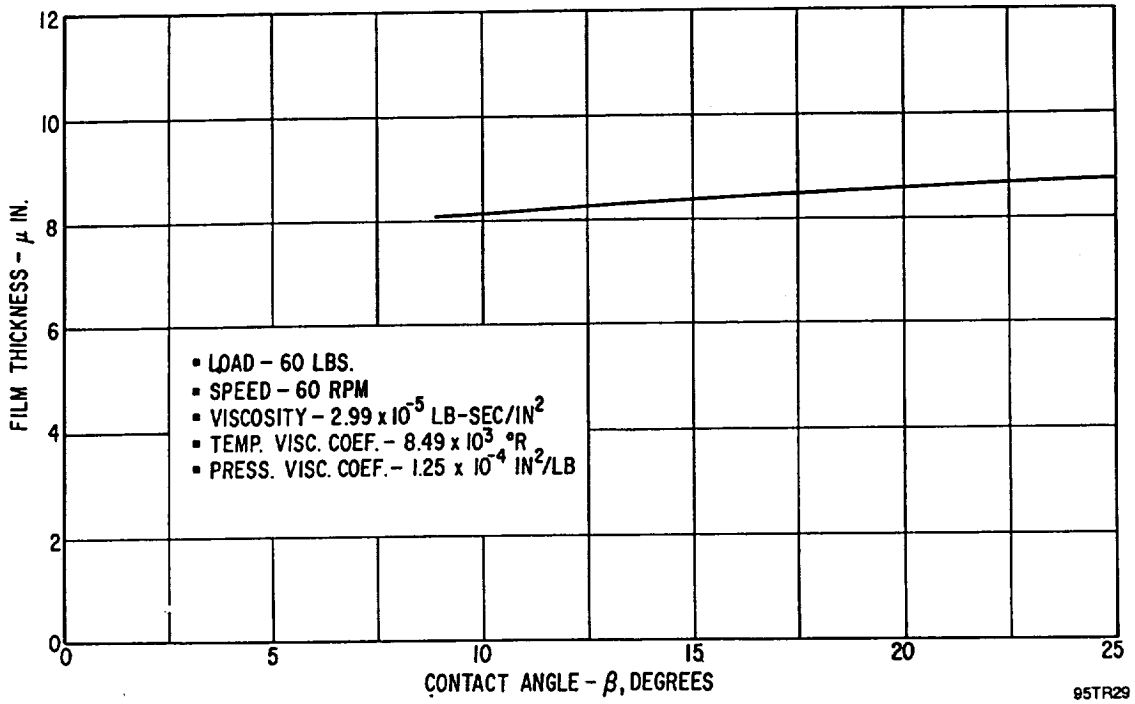

Figure 2-14c. Film Thickness vs. Contact Angle. From ^[64].

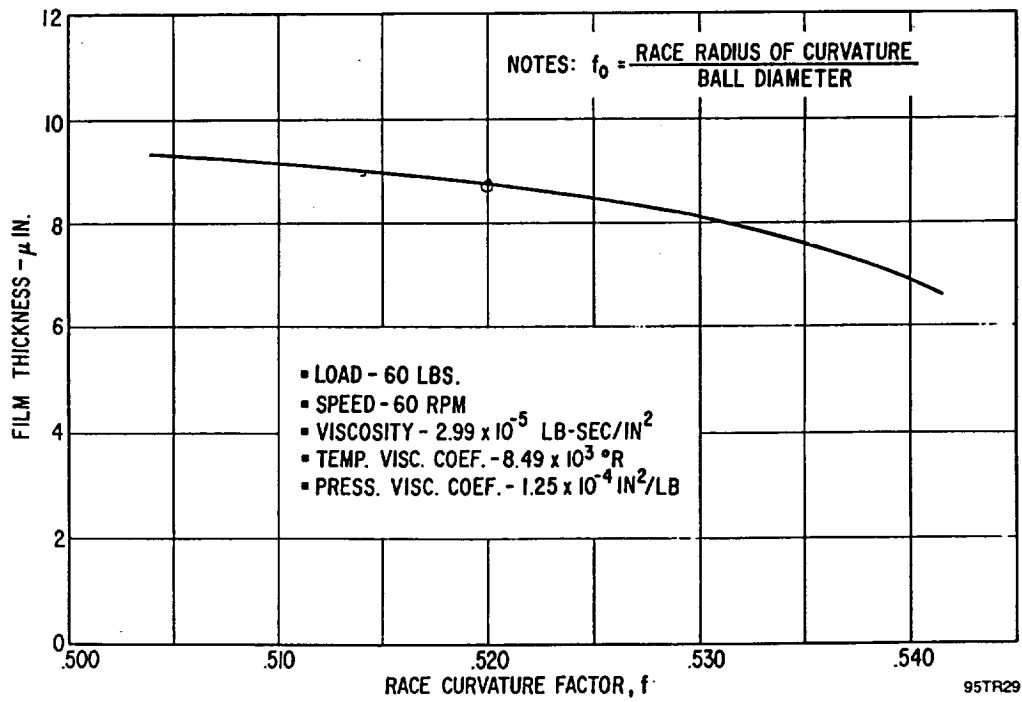

Figure 2-14d. Film Thickness vs. Race Curvature. From ^[64].

Table 2-11. Failure Modes of Rolling Element Bearings. From ⁽⁶⁷⁾.

- I. NONCONTACT FAILURES
 - 1. Bulk Failures
 - a. Overload Cracking
 - b. Overheat Cracking
 - c. Bulk Fatigue
 - d. Fretting of Fit Surface
 - e. Permanent Dimensional Changes
 - 2. Cage Failures
 - 3. Lubricant Failures
 - a. Degradation
 - b. Loss
- II. CONTACT FAILURES
 - 1. Wear Failures
 - a. Mild Wear
 - b. Severe Wear
 - 2. Plastic-Flow Failures
 - a. Cold Flow
 - b. Overheat Softening
 - 3. Contact Fatigue Failures
 - a. Subsurface Fatigue
 - b. Surface Fatigue
 - 4. Electrical and Magnetic Failures

95TR29

Table 2-12. Acceleration Factors. From ⁽⁶⁴⁾.

- 1. Speed
- 2. Load
- 3. Temperature
- 4. Surface Finish
- 5. Lubricant Starvation
 - a. Initial Removal
 - b. Temperature
 - c. Condensing Surfaces
 - d. Creep
 - e. Physical Removal
- 6. Lubricant Degradation
 - a. Temperature
 - b. Oxidation

95TR29

Table 2-13. Test Data Summary. From ¹⁸⁷.

TEST No.	BEARING TYPE	LOAD lbs	SPEED rpm	RUNNING TIME hrs	RUNNING TORQUE in-lbs	FAILED TORQUE in-lbs	TEMP. C	PRESSURE torr	H kg-m/sec	REMARKS
1a-1.....	1	1,500	60	20	2.3	34.0	25	760	0.167	Brown debris-dry
1a-2.....	4	1,500	60	2,327	2.0-4.0	Stopped	25	760	0.220	Bearing still wet-no debris
1a-3.....	5	1,500	60	495	4.0	19.0	25	760	0.228	Brown debris-dry
1a-4.....	5A	1,500	60	690	4.0	44.0	25	760	0.228	Brown debris-dry
1c-1.....	1A	1,500	105	495	1.0	4.8	25	760	0.126	Brown debris-dry
1c-2.....	1B	1,500	105	744	2.0	23.0	25	760	0.252	Brown debris-dry
1c-3.....	6B	1,500	105	1,445	2.4	23.4	25	760	0.360	Bearing still wet-no debris
2b-2.....	19	60	50	1,056	0.4	...	28	7×10 ⁻⁴	0.0242	0.001 cc Vac Kote
	20	60	50	1,056	0.4	...	28	7×10 ⁻⁴	0.0242	0.001 cc Vac Kote
3b-1.....	1	60	50	1,656	0.45	2.4	90	7×10 ⁻⁴	0.0272	
	8	60	50	1,656	0.45	2.4	90	7×10 ⁻⁴	0.0272	
3b-2.....	10	60	50	1,680	0.45	2.0	90	7×10 ⁻⁴	0.0272	Cage had metallic particles imbedded
	12	60	50	1,680	0.45	2.0	90	7×10 ⁻⁴	0.0272	
4a-1.....	6	1,500	60	455	2.5	13.2	25	760	0.180	Brown debris-dry
4a-2.....	6A	1,500	60	95	2.6	32.5	25	760	0.189	Brown debris-dry

95TR29

authors predicted that, at 25° C, the life of the lubricated bearing running at 50 rpm with a thrust load of 60 pounds would far exceed the target life of 7 years. At 75°C, the life would be about 7 years, and at 90°C, the life would be 1.6 years. It is important to know that these predictions are based on the results with a small number of bearings at a reliability of 83%.

In the discussions that followed the paper, Kingsbury pointed out that the authors had not included dynamic instability of the retainer in their list of possible failure modes, yet that had been the cause of an actual failure during prelaunch tests^[65]. Benzing and Strang observed that the authors used a four-fold increase in torque as a criterion for failure. They felt that torque variations would be a more realistic criterion. Finally, P.M. Ku questioned the authors conclusion that lubricant depletion was the basic failure mechanism because the failures in vacuum occurred between 1056 and 1680 hours. With an initial oil charge of about 1 gram, the discussor estimated that it would take about 40 years to evaporate the oil. This appeared to be a misunderstanding because the discussor was calculating room temperature losses, while the authors of the paper were running most of the vacuum tests at 90°C, where the losses would be much higher.

In two publications, the first an analytical study^[66], and the other an experimental follow-on program^[67]. Tyler, et al. described the results of a program to evaluate DMA ball bearings. They used a minimum intrusion technique to measure film thickness. The accelerating factors in their work were: surface roughness, lubricant viscosity, retainer material and retainer design.

The test bearings were typical DMA, 440C, ABEC-7, angular contact ball bearings with a 100 mm bore and a 19 ball complement of 15.9 mm diameter balls. The retainer was a standard cotton-phenolic. The contact angle was $26 \pm 1^\circ$. Both inner and outer race radii were 52% of the ball diameter. The balls had a finish of 1 μ in. Three different race finishes: 4, 8 and 16 μ in were prepared to determine the effect of roughness.

A schematic of the bearing test rig is shown in Figure 2-15. As the shaft rotates, the EHD films build up in the ball-race contacts and the shaft moves forward to accommodate the films generated between the balls-inner race and the balls-outer race. The films generated in the forward bearing (balls-inner race + balls-outer race) push the outer ring forward and this axial displacement of the forward bearing outer ring is sensed by an LVDT mounted on a baffle plate. The measured displacement is used to compute the average oil film thicknesses. Preliminary tests comparing the results of experiment and theory showed that the experimental film thicknesses were generally smaller than the calculated values, which may be due to an oil starvation effect.

A "conventional" method of supplying the oil was used. The oil was initially applied to the races and balls as relatively thick films. The retainers were presoaked with the oil to facilitate oil transfer to the balls during operation. Additional oil was stored in porous reservoirs located in the bearing chamber. It was suggested that these could generate a cover of oil vapor in the chamber space, thereby retarding evaporation of oil from the balls and races, and/or supply oil to the balls and races by migration. Finally, by suitably restricting the opening of the bearing chamber to the vacuum, loss of oil vapor by molecular flow to the vacuum environment was minimized. Table 2-14 describes the test oils used in this work.

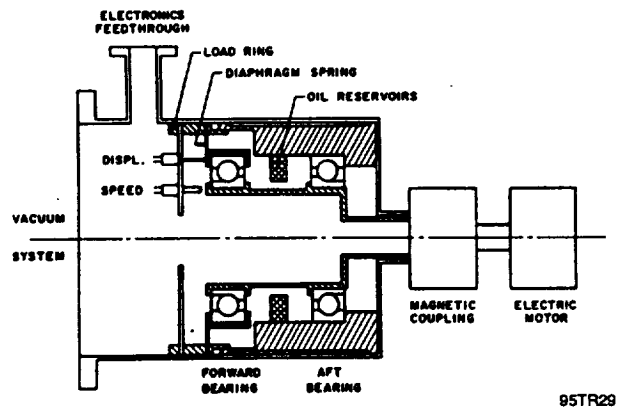

Figure 2-15. Schematic of Bearing Test Rig. From [66].

Table 2-14. Description of Test Oils. From [69].

OIL CODE	KIN. VISC., cP, at		SP. GR., γ _r , at 15.6°C (60°F)	DESCRIPTION OF BASESTOCK	ADDITIVES AND CONCENTRATIONS	
	37.8°C (100°F)	98.9°C (210°F)			ANTIOXIDANT	ANTIWEAR
A	29.5	4.5	0.868	Hydrocarbon by molecular distillation	None	None
C	97.1	10.3	0.879	Hydrocarbon by molecular distillation	None	None
AB	29.8	4.8	0.868	Oil A	Dioctyldiphenylamine (1.5%)	Lead naphthenate concentrate (0.5%)
CD	99.2	10.3	0.879	Oil C	Dioctyldiphenylamine (1.5%)	None
CZ	95.3	10.2	0.879	Oil C	None	Zinc dithiophosphate (2.5%)
W	29.8	4.8	0.868	Oil A	Dioctyldiphenylamine (1.5%)	Lead naphthenate concentrate (5%)
X	105.0	10.6	0.879	Oil C	Dioctyldiphenylamine (1.5%)	Lead naphthenate concentrate (5%)
Y	469.7	40.9	0.867	Synthetic hydrocarbon	Dioctyldiphenylamine (1.5%)	Lead naphthenate concentrate (5%)

The lead naphthenate concentrate contains 88% of lead naphthenate and 12% of a straight-chain hydrocarbon with a lower boiling point than lead naphthenate.

95TR29

In addition to the analytical computations in Part I of this work ^[66], one test was also run for 7000 hours with bearings that had deliberately roughened raceways (composite surface roughness about 8 μ in), an axial load of 890 N, and a shaft speed of 100 rpm. Apiezon C + 5% lead naphthenate was used as the lubricant. The purpose of the test was to determine the relationships between the experimental dimensionless minimum and central film thicknesses and those calculated from the Dowson and Grubin equations. Similar results were obtained. The time-averaged minimum film thickness ratio for the ball-inner race contact in the aft bearing, $\lambda_{m} = h_m / \delta a_c = 1.43$.

In Part II, this same test was continued for over 12,500 hours. No wear, pitting or torque increases were noted.

Tables 2-15 and 2-16 summarize the short-term and long-term experimental results obtained in Part II. In Table 2-15, short-term tests to evaluate the effects of oil viscosity, additives, etc., were described.

As shown in Table 2-16, using a lower viscosity oil (54 cs at 25°C), and an outer ring-riding retainer, resulted in two bearing seizures at about 4000 hours. However, with a ball riding cage, the same oil was still effective after 4440 hours of operation. The results of these experimental evaluations showed that although the conventional method of oil supply produces a less than flooded condition, even a low viscosity oil forms continuous EHD films.

An attempt to determine the ability of the retainer to supply oil to the contacts was not successful. A standard porous phenolic (7%), a porous nylon (25%), and a porous polyamide (27%) were evaluated. At the start of the test, the balls and races were clean and dry, but the retainers were impregnated with oil. As shown in Table 2-15, even after 24 hours of operation at 890 N and 25 rpm, neither the phenolic nor the polyamide supplied enough oil to create a measurable film. The nylon supplied oil from the start, but severe starvation was observed during 150 hours of run time.

Six long-term tests were run at room temperature with a bearing load of 890 N (200 lbs) and a speed of 100 rpm. The results are summarized in Table 2-16. Tests nos. 1 and 2 were lubricated with the same low viscosity oil (54 cs at 25°C). They were run to evaluate the effect of roughness. In both cases, the EHD behavior was less than flooded, but was not significantly affected by the composite ball-race surface roughness. Test no. 1 failed after 3836 hours, while test no. 2 failed after 4294 hours. Both of these failures were caused by the retainers in the aft bearings being pushed against one side of the outer ring land so that they jammed the bearings. Considerable wear was found in the ball pockets. The balls and races were well-lubricated with no visible wear. It was concluded that the retainer wear caused both failures. The third test, with rough raceway surfaces and a higher viscosity oil ran effectively for 12,768 hours with no signs of distress.

The last 3 tests in Table 2-16 were run with a ball-riding cage. Rough bearings were used to try to induce some kind of distress. Composite roughness did not seem to have any effect on EHD lubrication. Tests 4 and 5, which were lubricated with the lighter petroleum oil, showed no surface damage or wear of the balls and races in spite of the fact that the minimum film thickness was so low. However, the use of rougher surfaces did cause retainer wear. Test no. 6 with medium viscosity petroleum oil was effectively lubricated.

Table 2-15. Short-Term Exploratory Test Summary. From [17].

TEST SERIES	VARIABLE STUDIED	TEST OIL	v_0 , CS (25°C)	CAGE MATERIAL (POROSITY)	RESERVOIRS	INITIAL FILMS, μm	δ_0 , μm	LUBRICATION PERFORMANCE
I	Oil viscosity	W	54	Phenolic (7%)	Yes	3-4	0.10	Starved behavior
		X	225	Phenolic (7%)	Yes	3-4	0.10	Starved behavior
		Y	1000	Phenolic (7%)	Yes	3-4	0.10	Flooded behavior
II	Oil additives	CD	225	Phenolic (7%)	Yes	3-4	0.10	Negligible effect
		CZ	225	Phenolic (7%)	Yes	3-4	0.10	Negligible effect
III	Ball-race roughness	X	225	Phenolic (7%)	Yes	3-4	0.18	Negligible effect
IV	Initial film thickness	X	225	Phenolic (7%)	Yes	~0.1	0.10	Negligible effect
		X	225	Phenolic (7%)	Yes	~0.1	0.18	More starvation
V	Initial film thickness	X	225	Phenolic (7%)	No	~0.05	0.10	Cage wedging
		X	225	Phenolic (7%)	No	~0.025	0.10	Severe starvation
VI	Cage material	X	225	Phenolic (7%)	No	No	0.10	No oil transfer
		X	225	Nylon (25%)	No	No	0.10	Severe starvation
		X	225	Polyimide (27%)	No	No	0.10	No oil transfer

All tests conducted with outer ring-riding cage. Laboratory temperature ~25°C(77°F). Chamber pressure = vapor pressure of test oil. Bearing axial load = 220N (50 lbs) and 890N (200 lbs) for all test series, except Series VI at 890N only. Shaft speed = 50, 100, 150, 200 rpm at each load level.

95TR29

Table 2-16. Long-Term Endurance Test Summary.

TEST No.	TEST OIL	v_0 , CS (25°C)	INITIAL FILMS, μm	δ_c , μm	AVERAGE Λ_m	TEST TIME, h	REASONS FOR TEST TERMINATION
WITH PHENOLIC OUTER RING-RIDING CAGES							
1	W	54	3-4	0.18	0.71	3 836	Rig locked up due to cage wedged against outer race land in aft bearing.
2	W	54	3-4	0.10	1.25	4 294	Rig locked up due to cage wedged against outer race land in aft bearing.
3	X	225	3-4	0.18	1.43	12 768	No failure; test suspended.
WITH PHENOLIC BALL-RIDING CAGES							
4	W	54	~0.1	0.33	0.21	4 440	No failure; test suspended.
5	AB	54	~0.1	0.33	0.26	4 440	No failure; test suspended.
6	X	225	3-4	0.33	0.78	4 440	No failure; test suspended.

All tests conducted with oil-impregnated cages and reservoirs. Laboratory temperature ~25°C (77°F). Chamber pressure = vapor pressure of test oil. Bearing axial load = 890N (200 lb). Shaft speed = 100 rpm. Λ_m for aft bearing ball-inner race contact averaged for the latter part of test duration.

85TR28

Ward^[68] reported on the results of a more detailed analysis of the failed DMA bearings from the tests that Tyler, et al.^[67] had run. These were the tests where changes in the film thickness ratio, Λ , were used to accelerate the results. Λ is defined as the ratio of film thickness to composite surface roughness of the balls and races. Three ratios were used having initial conditions that were described as low, medium and high film thicknesses. After running for 3836 hours, the rear bearing with the lowest Λ seized (this was an outer ring-guided cotton phenolic retainer). The bearing had been lubricated with Apiezon A base stock containing 5% of a lead naphthenate solution and 1.5% of an oxidation inhibitor, p,p'-dioctyldiphenylamine. Seizure was caused by the retainer being pushed against one side of the outer ring land, and jamming the bearing.

The test bearing had carried a 890 N (200 lb) axial load and was run at 100 rpm. During the test, the minimum film thickness was initially 0.07 μm (6.9 μin). After the test, the inner and outer races and the balls were wet with lubricant. No free lubricant was visible on the retainer. There was considerable oil-soaked debris around some ball pockets and on the races and balls. This debris appeared to have some fibrous material wet with oil and a few shiny fragments which appeared to be metal. When the balls and races were cleaned, very little damage was visible on the balls (minor scratches) and the races looked like new.

The phenolic retainer from this aft bearing had the most damage. The author concluded that seizure due to excessive retainer instability was the probable cause of failure, partially because of the wear debris in the retainer pockets and partially because the retainer face had been rubbing against the outer race land in one location. The forward bearing showed similar damage. The ball tracks had many small indentations; the balls had minor scratches but were in good shape. The retainer was definitely worn and had blackened areas where it had rubbed against the outer race land.

Infra-red analysis was used to determine the condition of the lubricant. To obtain control samples for comparison, Four-Ball tests were run using both 440C and 52100 steel balls as sliding specimens. Apiezon C oil, and Apiezon C formulated with the same additives as the test oil were used in the Four-Ball tests. [In the ball bearing test, Apiezon A was the lubricant. The author did not believe that a change in base stock to a lighter and more volatile hydrocarbon would affect the results]. A 75°C (167°F), IR spectra showed only increases in the amount of lower molecular weight hydrocarbons. At 200°C (390°F), peaks indicating the formation of carbonyl groups were found, suggesting that carboxylic acids were forming at higher temperature. It was also noted that greater amounts of acid were formed with 440C than with 52100 steel and that the formulated Apiezon C had a significantly higher acid number than the straight Apiezon C. In any event, the Apiezon A formulated oil that was recovered from the test bearings after 3836 hours of test time also showed carbonyl peaks with at least one peak at the same absorption number as the Apiezon C from the Four Ball tests.

The main conclusion of this work was that seizure was caused by retainer instability and wear. The outer land-riding retainer showed considerable wear (2.42 grams). This indicates that the land-riding retainer may not be suitable for the application. It also shows that the phenolic may not provide enough lubrication for the retainer-outer race land interface.

The chemical degradation of the oil that was observed in the Four Ball tests is disturbing, but no information was given concerning the Four Ball test environment. If the tests were run in air, there would be a question as to what would happen in an inert environment or in a vacuum.

A second technical article on DMA bearings was also written by Ward^[69] in this same time frame. In that paper, the author described and discussed the methods that should be used to clean and lubricate DMA bearings for service. That paper, and a report by Babecki^[70] contain much pertinent information on the subject. In particular, they discuss the problems of examining, cleaning and lubricating the retainers. The uncertainties in determining the weight of the retainer and measuring the takeup of lubricant are potentially major sources of error.

The discussions printed at the end of Ward's paper^[69] provide more useful comments on the problem.

Davis, et al.^[71], from the Ball Aerospace Systems Division, described an extensive 3-year study which was done to acquire pertinent information on despin mechanical assemblies (DMA). The overall objective of this program was to provide a data base for validation of the lubricant life/performance prediction methods which have been developed by AFWAL/MLBT for despin mechanical assembly (DMA) bearings. The program consisted of 3 Tasks:

Task I - Compilation and analysis of a comprehensive data base on the lubrication and operation of DMA bearings and slip rings. (The authors said that they tried to obtain background data from the aerospace industry, but virtually nothing was obtained. Some information was classified, much was proprietary, and the rest would have required manpower to obtain pertinent data).

Task II - Instrumentation and full scale tests of a DMA. Nine tests were run, 5 performance tests and 4 lubricant tests. Table 2-17 is a summary of the tests that were run and Table 2-18 describes the lubricants used.

Task III - Assessment of results.

The following instrumentation was used in this program:

Bearing torque transducer - torque from the motor module was transmitted to the main bearing and slip ring assembly (SRA) through a dual torque transducer. Torque values for the pair of bearings and the SRA were measured.

Bearing contact angle - using sensors that looked at the DMA housing speed and the retainer speed, the ratio of the bearing retainer speed to the DMA housing speed was obtained, and this was used to calculate the contact angle.

Bearing electrical resistance - resistance measurements were made across each DMA bearing by means of contact buttons which touched the outer rim of the outer bearing ring and the bore surface of the inner ring. Direct resistance readings were made by the HP3456 Digital voltmeter. The applied current was varied automatically to match the sensed resistance range.

Bearing inner and outer race temperatures - temperature sensors were mounted on the DMA at 8 locations, two near each main bearing race. Figure 2-16 is a schematic of the way the sensor was mounted.

All bearing tests were run at 60 rpm \pm 10% with an axial load of 280.2 N (63 lbs). In the first 5 performance tests (nos. 1,2,3,1A and 4), Apiezon C plus a lead naphthenate concentrate BASD 37981/36194 was the lubricant. This oil was also used on the slip ring assemblies in all of the tests. The slip ring assemblies were not relubricated, they ran on the same charge of lubricant for the whole program.

Table 2-17. Test Summary. From⁽⁷⁾.

Test No.	Test Name	Bearing Lubricant	Comments
1	Baseline	BASD 37981/36194	Establish Baseline DMA performance
2	Misalignment	BASD 37981/36194	Determine effect of uneven preload in upper bearing
3	Depleted Lubricant Quantity	BASD 37981/36194	Simulate depleted lubricant condition
4	1A (Baseline)	BASD 37981/36194	Retest of Baseline Test, validate instrumentation
5	Reduced Separator Clearance	BASD 37981/36194	Determine effect of a reduced clearance between bearing inner race and separator inner diameter
6	L1	BASD 36233	Determine effect of an antioxidant additive
7	L2	MLO 83-514	Evaluate performance of a PAO Alkyl Benzene
8	L3	Polyol Ester	Evaluate performance of Polyol Ester
9	L4	MLO 83-514	Retest of Test L2, Validate instrumentation

95TR29

Table 2-18. Description of Lubricants. From ^[7].

Lubricant Designation	Base Oil	Additives	Used in Test	Viscosity (cs) at 100°F	Viscosity (cs) at 210°F
1. Vackote (BASD 37981/36194)	Apieton C	Lead Naphthenate	1 through 4	105	10
2. Vackote (BASD 36233)	BASD 37981/36194	Dioctyldi-phenyamine	L1	105	10
3. MLO 83-514	PAO Alkyl Benzene	Lead Naphthenate	L2 and L4	121	not available
4. Polyol Ester	Polyol Ester	Organometallic Oxidation Inhibitor	L3	56	8.6

95TR29

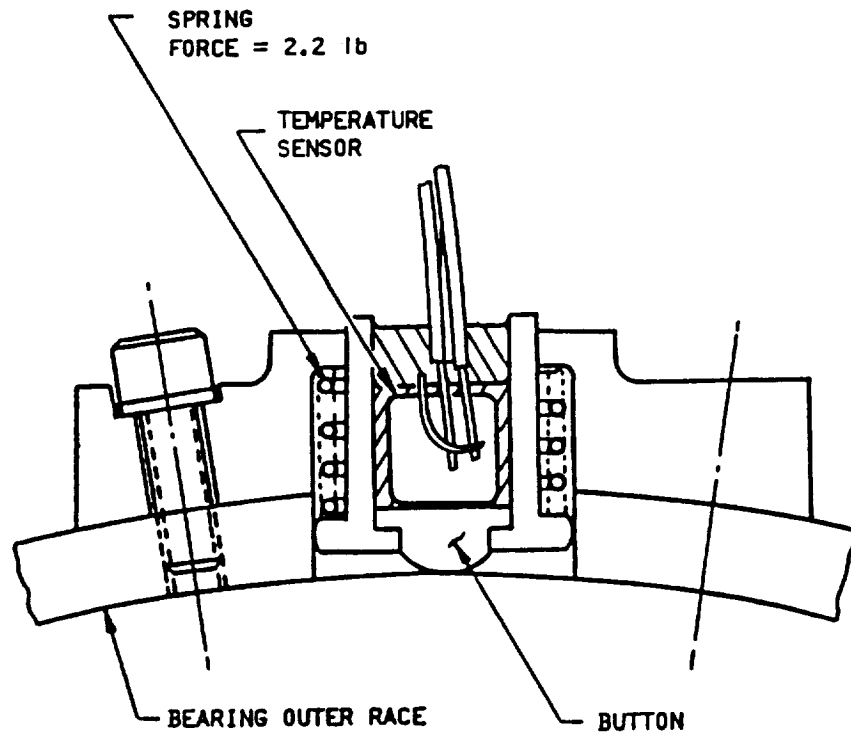

95TR29

Figure 2-16. Temperature Sensing Technique. From ^[7].

Infra-red spectroscopy was used before and after the tests to determine if the oil had undergone decomposition. In some cases, spectra showed significant acid carbonyl adsorption bands, indicating some breakdown. Wear particle counts were also made after the test runs were completed.

One particular problem that was encountered in some of these tests was the torque measurements. The data were contrary to well-established trends. For example, the torque in some tests increased with increasing temperature. It should have decreased because the viscosity of the oil was decreasing. Problems were also encountered with the slip ring assembly torque values. The lead wire bundle was quite stiff and that interfered with the readings.

For Test 3, the assembled bearings were rinsed in a solution of hexane containing 5% Vackote oil and the hexane was allowed to evaporate, thus simulating a starved oil condition. The bearing torque was low (normal for minimum lubricant film), and it varied inversely with temperature (as did the viscosity). The particle count after the test was higher than normal and more metallic debris was found, all typical of lubricant starvation.

Performance test No. 4 (Tables 2-17 and 2-19) demonstrated the effect of using a retainer with reduced clearance between the inner race land and the inner diameter of the retainer. Torque started high, but the bearing ran in during the first 300 hours and remained very stable during the rest of the test.

The last four tests were lubricant evaluations. Table 2-18 describes the lubricants used, and Table 2-19 shows relative ranking of the results. For a baseline, BASD 37981 (Apiezon C + lead naphthenate), the same oil used in the performance tests, was the lubricant of choice for the first evaluation (L1). However, 2% of an antioxidant, dioctyldiphenylamine, was added to the oil. This is why the lubricant code number was changed to BASD 36233. The contact resistances for both test bearings were very high at the start of the test. It stayed high for the upper bearing throughout the test. In contrast, the resistance for the lower bearing decreased to negligible values and, beyond 150 hrs, only minimal changes were seen. The authors concluded that the antioxidant changed the performance of the lubricant by a significant amount. It was also noted that only half the antioxidant was present at the end of the test. Possibly, volatilization could account for the loss.

Test No. L-2 (PAO Alkyl Benzene) was run to assess the effect of using a lubricant with different rheological properties. The authors added 5% lead naphthenate. This test gave low bearing torque noise. At the end of the test, the upper bearing resistance was insignificant, indicating a lack of lubricant. The bearing rinse analysis indicated that this bearing had about 40% of the normal amount of oil remaining. Visual inspection indicated that lubricant had migrated from the upper to the lower bearing.

Test L-3 (Polyol Ester). This synthetic lubricant had a lower viscosity at 100°F than any of the other lubricants (see Table 2-18). As a result, the bearing torque values were lower than they were for the other lubricant tests. The torque noise and resistance values also showed an improvement. At the end of the test, it was found that the metallic particle count for both bearings was very low.

Test L-4 (PAO Alkyl Benzene) was a repeat of test L-2. It was run to validate the results of that test, especially the bearing torque data. The test data closely resembled the results of test L-2 and the test was shut down after 28 days.

Table 2-19. Relative Characteristics of DMA Operational Parameters. From [7].

TEST NO.	BEARING TORQUE	BEARING TORQUE NOISE	UPPER BEARING RESISTANCE	LOWER BEARING RESISTANCE	TEST PURPOSE
1	MODERATE	MODERATE	MODERATE	MODERATE	BASELINE
2	HIGH	MODERATE	HIGH	HIGH	MISALIGNMENT
3	LOW	LOW	LOW	LOW	DEPLETED LUBRICANT
1A	MODERATE	MODERATE	MODERATE	MODERATE	BASELINE
4	MODERATE	MODERATE	MODERATE	MODERATE	REDUCED SEPARATOR CLEARANCE
L1	MODERATE	HIGH	HIGH	MODERATE	BASD 36233
L2	MODERATE	LOW	MODERATE	LOW	PAO ALKYL BENZENE
L3	LOW	LOW	LOW	LOW	POLYOL ESTER
L4	MODERATE	LOW	MODERATE	LOW	PAO ALKYL BENZENE

95TR29

Both the PAO Alkyl Benzene and the Polyol Ester gave lower torque, less torque noise and less wear than the other test lubricants. Many of the variations in torque appeared to be due to variations in lubricant quantity.

For future work, the authors recommended:

- Further studies of the mechanisms of lubricant delivery
- A more complete investigation of the use of electrical resistance. (The authors stated that the resistance measurements could be the key to understanding torque variations)
- In future tests, continuous monitoring and evaluating analog torque and resistance data should be done.

Kingsbury^[72] reported on the design and testing of large high-speed bearing without a retainer. This bearing was being evaluated because of problems in space with the spin axis bearings in one of the Control Moment Gyroscopes of Skylab. It was suggested that there might be a problem with the lubricant delivery from the phenolic retainer to the ball race contacts, possibly coupled with retainer instability.

The replacement bearing had the following attributes:

1. No retainer to go unstable
2. A well-defined lubrication system
3. Positive oil delivery to both inner and outer races at zero g.

Two tests bearings were built as retrofits and were tested in the laboratory for 13,000 hours at 8100 rpm. One oil reservoir apparently leaked oil through a faulty seal although it still had some oil left. The other bearing had been misaligned in assembly so that the plane of the race groove was not perpendicular to the assembly spin axis. A section of this bearing had been ground away to form a lubricant flow path, and this apparently created a stressed area which finally manifested itself as a fatigue spall. Despite these two mishaps, which were not related to the central problem of evaluating a retainerless bearing, the concept was clearly demonstrated.

In Europe, Todd and Parker^[73] evaluated the possibility of using dry film lubrication for the ball bearings in the despin mechanism assembly of the GIOTTO Spacecraft. Those bearings were run at 15 rpm. The thermal environment that was anticipated for this mission (-40°C to +60°C) favored the use of solid rather than liquid lubrication.

Evaluations of bearings lubricated with ion-plated lead films and a leaded bronze retainer, or with just a PTFE composite retainer demonstrated that lead film lubrication provided better torque noise behavior.

To accelerate a life test, the lead-lubricated bearing was run at 100 rpm with periodic slowdowns to 16 rpm so that the torque spectrum could be measured. The test was run for 1×10^8 revolutions, almost 700 days at 100 rpm without developing excessive torque noise. That was the equivalent of more than six times the required life.

The mission was completed successfully.

2.2.6 Summary of Accomplishments and Needs

Good progress has been made on many aspects of the problem of space lubrication, particularly on the application and use of solid lubricants and soft metal films. Solid film lubrication is especially important in cases where the condensation of volatiles on optical surfaces must be prevented, or where low temperature operation will cause oils to congeal. Although it is sometimes possible to design baffles to keep volatiles away from critical surfaces, the use of solid lubricants is preferred as long as the cycle life is not excessive.

As far as liquid lubricants are concerned, synthetic hydrocarbons, such as the polyalphaolefins and polyol esters, show promise as tailor-made space lubricants. There are still concerns about the possibility of the lubricants evaporating away, leaving the bearings unprotected. However, this may not be as serious a problem as had been envisioned earlier [49, pp. 73 and 86]. It has been hypothesized that the lighter oil fractions evaporate away, leaving the heavier, lower vapor pressure lubricant fractions behind. It seems as though this would result in higher bearing torque because of the accompanying increase in viscosity, but the results reported in [71] showed decreases in torque with long times in vacuum. The authors of that report proposed that the drop in torque was due to a loss in film thickness. That would not be a desirable situation either, but more work is necessary to understand how and where lubricant is lost.

While the perfluoropolyalkylethers have very low vapor pressures and are reasonable lubricants, their high cost, poor additive solubility, and tendency to polymerize when lubricating steel, will probably restrict their use as more experience is gained with synthetic hydrocarbons.

Rolling contact bearings are a key element in component design for space. Their positional capability, load-carrying capacity, ability to function with minimum amounts of lubricant, low torque requirements, and utility over wide speed ranges put them in a special category. At the present time, the lubrication of these bearings is a critical item. For lightly loaded rolling contact bearings, solid lubricant or lead films can be used, but they have a very finite life. Self-lubricating composites, in the form of retainers, can provide transfer films for lubricating the ball and race contacts, but these are not suitable for high loads or very long life because they function by a controlled wear process. The gradual accumulation of debris and loss of dimensional accuracy limits the life of the bearing.

For long life, high cycle applications, liquid lubricants appear to be the best choice for rolling contact bearings. The bearings need a very small quantity of oil, just enough to form an EHD film. Any excess penalizes bearing torque and the bearing operating temperature. However, small quantities of fresh oil will be needed to maintain adequate lubrication. To supply makeup lubricant, the bearing retainers are made of porous plastics, such as laminated phenolics or porous polyimides, and porous plastic reservoirs are also located in proximity to the bearings. These are all impregnated with oil in hopes that it will bleed out slowly and replenish any oil lost from the bearing. Little has been done to understand the flow paths and distribution of oil in the ball bearing in spite of the fact that this is a major concern. In addition, the use of porous laminated-phenolic retainers and, more recently, porous polyimides as reservoirs for supplemental lubrication has raised questions about whether these materials will dispense oil or absorb it in service. A number of technical papers have described analytical programs to optimize ball bearings for particular applications and as aids to minimize retainer instability [e.g., 50, 57, 59, 60, 61, 63, 65]. As engineers gain more familiarity with these programs, performance should improve.

Much more emphasis on instrumentation for monitoring the performance of mechanical systems, especially ball bearings, is needed. Progress in the development of miniaturized sensors, using IC technology, will make it possible to build very rugged and reliable instrumentation to monitor bearings and other mechanical components throughout their useful lives.



3.0 DEVELOPING AN ACCELERATED TESTING TECHNOLOGY ROAD MAP

The design and development of hardware for use in space always lags behind other aspects of satellite development. It is understandable that scientific endeavors in space, as well as programs such as weather or communications, have upstaged engineering and hardware problems. However, this postpones engineering decisions, leaving only limited time for the design, testing and performance evaluation of mechanical components. Future plans for longer missions will require that much more effort be devoted to solving space hardware problems.

One promising solution would be to develop a more rational approach to the technique of accelerated testing. By carefully increasing the severity of the test conditions, it should be possible to hasten early failures without altering the actual mode of the failure. This concept of accelerated testing presupposes that the failure mode is reasonably well understood and that the operating conditions used in these tests meet two requirements:

- a) The severity of the test conditions can be adjusted to magnify the mode of the failure.
- b) The new test conditions will not be severe enough to cause the component to undergo a different mode of failure, i.e., a transition from mild wear to galling and seizure.

Figure 3-1 outlines the lubrication regime that is of interest. This is the thin film regime, the transition from hydrodynamic fluid film lubrication to a mixed film region, where surfaces are only partially supported on an oil film and there is a significant amount of asperity contact taking place through the film. Most of the slow-speed, lubricated contact mechanisms that are used in space operate under these conditions.

It is difficult to stay within the brackets, or even to support the claim that the test conditions favor a certain operating regime, unless means are available to monitor performance and demonstrate the failure mode.

In the Technical Background section, a number of studies of DMA bearings were reported [49, 62, 64, 66-69, 71, 73]. Various acceleration techniques were used, including speed, load, temperature, surface roughness, lubricant starvation, etc. The effect of lubricant type and retainer material was also investigated. Although much time and effort was spent on these programs, the results did not lead to clean solutions. We still do not have the kind of predictive capabilities that would make it possible to locate impending failures before they occur.

The problem is not with the concept of accelerated testing, it is with the limited capabilities of the instrumentation that is being used. There is a need for non-destructive sensor techniques that can indicate an impending problem without shutting down the test or experiencing a catastrophic failure. Many of these techniques are already established. As noted in the Technical Background section, methods of monitoring motor current, speed, temperature, load and torque have all been used in DMA studies. However, the techniques being used do not reflect the advances that have been made in sensor technology. The truth is, there is more sophisticated measuring, monitoring, and controlling capabilities in the engine of a today's automobile than there is in the

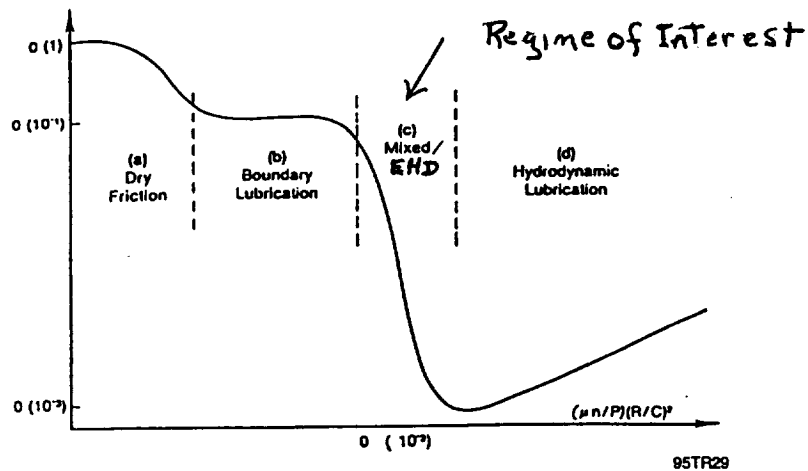

Figure 3-1. Tribological Regimes. From ¹⁰⁷.

mechanical assembly of a multi-million dollar satellite. This is where the emphasis must be placed if accelerated testing is to become a realistic tool for predicting life. While the immediate goal is concerned with ground tests, the ultimate goal is to be able to monitor performance in both ground and orbit locations with the same instrumentation, built-in as an integral part of the mechanical assembly.

Table 3-1 lists a number of sensors that are used routinely in the laboratory to perform various tasks. The first step in outlining a program directed at this problem is to decide what is to be monitored and measured. The operating characteristics of interest include:

Characteristics	Typical Sensors Used
Sound and Vibration	Accelerometers or Capacitance Probes
Temperature	Thermocouples or Thermistors
Speed	Magnetic or Optical Pickups
Torque	Strain gages or Piezoelectric Sensors
Sliding or Rolling	Electrical Contact Resistance or Sound

95TR29

It is important that the sensor outputs provide some "overlap" when the performance of practical bearing systems is being monitored. For example, consider the case of a ball bearing operating on a very thin EHD film. Torque readings will be minimal because seal losses are low. However, electrical contact resistance and sound or vibration measurements will show when isolated metal-to-metal contacts are being made through the lubricant film. Here, the degree of contact is the critical factor. Isolated asperity peaks may touch, but this will not necessarily result in wear or surface damage.

In similar fashion, lubricant starvation will provide optimum torque values when the lubricant films are thin, but this stage could be followed by decreasing contact resistance and increasing sound or vibration as lubricant is depleted from the contact area.

Table 3-1. Typical Sensors Used in the Laboratory.

1. Temperature sensors - thermocouples, thermistors, and infrared detectors.
2. Position sensors - eddy current or capacitance probes, LVDT sensors, lasers and ultrasonic range detectors.
3. Vibration sensors - accelerometers, strain gages, capacitance probes.
4. Speed sensors - magnetic pickups, optical encoders, tachometers.
5. Force or pressure - piezoelectric or piezoresistive sensors.
6. Metal-to-metal contact detectors - electrical resistance or voltage drop.
7. Chemical sensors - dielectric constant.
8. Optical sensors - densitometers, IR, UV fluorescence, spectroscopy, photoconductivity cells, photodiodes.
9. Acoustic emission - ultrasonic and sonic detectors.

95TR29

It should be noted that the literature does contain instances where more advanced sensors have been used to monitor the performance of bearings in space. For example ^[49], on page 40 describes the use of an accelerometer to detect a "groan" from the bearing and it was found by computer simulation of the bearing and separator that the separator would oscillate or wobble under certain conditions, and this was the cause of the groan. In the same reference ^[49], on page 52, a method of sensing electrical brush wear in space was also described.

The use of a ball bearing torque test to evaluate bearing condition was reported in ^[6]. In another study ^[74], the use of a low speed dynamometer test to evaluate the torque characteristics of instrument ball bearings was described. Both authors claimed that this technique was able to pinpoint faulty bearings. One encouraging finding in ^[74] was the statement that the torque trace of a "non-wet" area in the bearing looked the same as the metal damage trace. This offers a possible means for detecting a "non-wetted" condition in service. This technique was also said to be a useful tool for early detection of lubricant degradation because it could detect an increase in lubricant viscosity due to polymerization.

3.1 Items of Work Needed for the Technology Road Map

The following list itemizes the related studies that will be needed to define the Technology Road Map:

3.1.1. Identification of Ball Bearing Computer Programs

A number of specialized computer programs are available to predict the performance of ball bearings and retainers. These include:

- BBMTI, Mechanical Technology Incorporated, based on A.B. Jones and others
- RAPIDREB, U.S. Air Force, Dynamics of Rolling Element *Bearings
- ADORE, P. Gupta, Inc.
- BASDREL, Advanced Controls Technology
- etc.-

3.1.2 Selection and Evaluation of Monitoring Sensors

To measure the degradation of components under accelerated test conditions, careful monitoring and trending of incipient failures is essential. Without trend monitoring, accelerated tests will merely consist of a series of failure times. A failure is just a discrete measure of some operating parameter anyway. If a scalar measure of operating parameters can be made during a test (i.e., power consumption is normal, no obvious vibration is being sensed, torque is acceptable, etc.), then these critical operating parameters could be used for future evaluations of system reliability and life. Furthermore, the trending examination of test parameters could lead directly to ways for changing the parameter(s) to engineer extended life and better performance.

Today, much information exists on using acoustics to evaluate the quality of mechanical systems. Monitoring capabilities such as these should be reviewed for their simplicity of implementation. This is just one of the sensory systems that mimic our own way of monitoring how a complex mechanical system is performing.

3.1.2.1 Accelerometers. The electronic sensory detection of bearing faults dates back to the early 50's. However, modern sub-miniature electronics provides for "real-time" analysis of danger signals ^[75, 76]. Sensor outputs can be collected from laser vibrometers or parabolic microphones, but miniature piezoelectric crystal accelerometers seem to offer the most promise for our purposes. Benzing and Strang ^[49] described an anomaly, torque fluctuations, that occurred in two satellites of the same design. These fluctuations caused a pointing error of the antenna platform. The problem was first detected by an accelerometer on board the satellite. The fluctuations appeared to correlate with the temperature; the lower the temperature, the greater the amplitude and frequency. Using computer simulation, it was shown that the cause was retainer instability due to a combination of high lubricant viscosity at low temperature and the use of a conical shape for the ball pockets. Having pinpointed the problem, the torque fluctuations were reproduced in the laboratory. The problem was resolved by turning up the motor housing heaters. Subsequent satellites of this type were built with an improved cage/ball-pocket design.

3.1.2.2 Temperature Measurements. Because of mismatches in differential thermal expansion coefficients, and the sensitivity of liquid lubricant viscosity to changes in temperature, it is important to be able to monitor ambient temperatures and temperature gradients within the satellite, and as close as possible to the bearings. The ambient temperature inside the satellite can affect bearing clearances and will control the bulk viscosity of the oil. In addition, the inlet temperature of the oil in an EHD contact determines the film thickness.

3.1.2.3 Electrical Contact Resistance. Electrical contact resistance measurements are gaining recognition as a good means to detect the performance and type of interaction between two lubricated surfaces ^[71-76]. Although a sound method of analyzing contact resistance measurements has existed since Furey published his work ^[77], little has been accomplished in extending an understanding of the physics of this phenomenon, or quantitatively predicting the results.

This technique was used by Bolzio et al. ^[80] to evaluate slow speed journal bearings, and by Perrotto et al. ^[81] to monitor the effects of abrasive contamination on rolling contact bearings. In those studies, six resistance datums (center scale resistance settings) were used, ranging from 1 ohm to 100,000 ohms. The input voltage was 0.1 volts. The basic circuit is shown in Figure 3-2. In a method similar to that used by

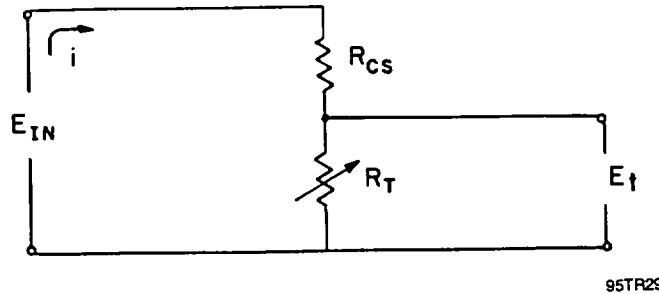

Figure 3-2. Circuit for Contact Resistance Measurements. From ^[80].

Furey ^[73], the instantaneous contact resistance R_r , in ohms, is processed to yield a measurement of the percent contact that occurs. Through a detector which is set at the center scale resistance, R_{cs} , for the tests, the percent contact is measured as the percent of time that R_r is less than R_{cs} . Chu and Cameron ^[78] note that percent contact measurements must be given in terms of the datum resistance (R_{cs}) used, since the contact resistance does not vary between infinite resistance and a dead short, as assumed by Furey. According to Furey's convention, the contact resistance varies as a square pulse. This would imply that the percent contact is independent of R_{cs} . This is not the case as can be seen from the actual data shown in Figure 3-3.

However, it is mentioned in ^[78] that the dependence of percent contact measurements on the datum resistance is due to variations in the minimum resistance of a contact. Actually, results such as the data shown in Figure 3-3 across such a broad spectrum of contact resistances can occur only if the contact does not instantaneously vary between a separation resistance, and a minimum resistance at contact. Generally, what is thought to occur is that a contact resistance varies sinusoidally. Asperities come into contact, the contact area increases, they reach maximum contact and then they separate. A model such as this would imply that a change in R_{cs} (the datum resistance) would affect the percent contact measurement, which agrees with the data. Furthermore, variation in the minimum resistance at contact depends on the maximum asperity contact diameter, and this, in turn, depends upon the separation of two surfaces, which is basically a fluid film effect.

A schematic of the contact resistance set-up that should be used in these tests is shown in Figure 3-4 ^[80]. The contact analyzer in the figure is used for the contact resistance measurements. The response time of this instrument is 100,000 Hz, thus contact resistance fluctuations at a frequency of 10^5 per second can be accurately followed. The wave pulses are not shaped; however, the analog percent contact signal is filtered for the 100 percent contact signal, and scaled for the 0 percent contact signal. An oscilloscope is included for visual display and for data acquisition.

3.1.2.4 Speed and Torque Measurements. A magnetic pickup will probably be used to measure speed. Torque measurements can be made with a strain-gaged beam or a piezoelectric transducer. If other, more promising techniques are uncovered, these will also be considered.

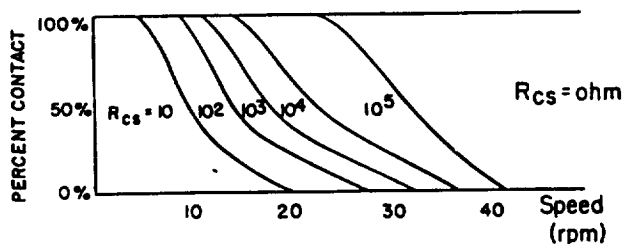

95TR29

Figure 3-3. Percent Contact vs. Speed for Different R_{cs} . From [80].

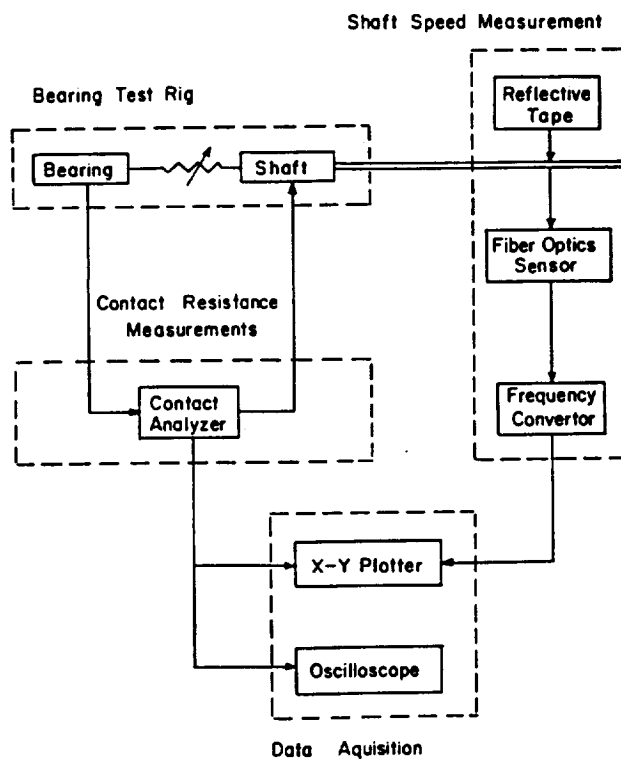

95TR29

Figure 3-4. Schematic of Instrumentation for Contact Resistance Measurements. From [80].

3.1.3 Additional Tasks Required for Technology Road Map

3.1.3.1 Effect of Microgravity on Flow Paths of Lubricants. There are two processes of interest here. One process is the absorption and retention of lubricant by the porous plastic retainers and reservoirs that store and, hopefully, release fresh lubricant as it is needed. The other process is concerned with the flow paths of the oil as it migrates over the inside surfaces in the bearing cavity. Geometrical considerations, the physical and chemical properties of the lubricants, and the properties of the materials used for the bearing cavity will all be considered. One major objective of this work is to generate enough information to be able to model fluid behavior against surfaces and in capillary pores. Another is to look for means to control oil flow paths.

a.) The Performance of Retainer Materials

The selection of porous retainer materials is a road block that must be addressed. Some investigators have explored the possibility of using other materials to replace the laminated phenolics [e.g., 50, 67]. These included porous nylon and porous polyimide. However, neither candidate showed much promise. Perhaps the concept of using a porous retainer material and impregnating it with lubricant is part of the problem. It seems reasonable to believe that when the balls are pushed along by the retainer some oil can bleed out of the retainer structure and provide a small additional supply of lubricant. However, when oil-impregnated retainers were used in clean, dry ball bearings, they were not able to lubricate the bearing [67].

In this recommended Roadmap Study, the performance of oil-impregnated porous nylon and polyimide retainers should be compared with retainers made of the same plastics, but containing solid lubricants such as MoS₂ or Teflon in their structure. (These must also be oil-lubricated.) We are hypothesizing that the oil-impregnated porous plastic retainers are, at best, marginal sources of lubricant and that the solid lubricant provides a margin of safety. It could be argued that the porous plastic retainers are needed to provide reservoirs of additional lubricant for the bearings but many investigators do not believe that they perform that function anyway.

Plastic composites with these solid lubricants are commercially available, and are presently being used as retainers in oil and grease-lubricated ball bearings for industrial and military applications. Perhaps the results might also be applicable to retainer stability.

One interesting note about laminated phenolic retainers is the lack of unanimity when it comes to their design. Inner race-guiding, outer race-guiding, and ball-guiding are all being used for DMA bearings. There was not much said about the retainer designs for control moment gyros. Since the design mechanical assemblies all see the same type of service i.e., axial preloads and low speeds, it seems likely that there should be one optimum design.

b.) Wetting and Spreading of Lubricants

The other lubricant-related process of concern here is the wetting and spreading behavior of the lubricant as it migrates around in the bearing cavity. Geometrical considerations, the physical and chemical properties of the lubricants, and the surface properties of the materials used in the bearings and the bearing housing will all affect the results.

Some experiments have been done in space by astronauts working in Sky-lab [82] and Apollo-Soyuz [83]. The behavior of liquid droplets, foams, and wicks were evaluated and useful results were obtained.

One of the authors of this report (SFM), participated in some wetting and spreading experiments and journal bearing studies on the shuttle flight Spacelab 1 in late 1983^[84]. For those tests, four mechanized fluid-dispensing modules were used, each with a different test oil. Each module contained three 440C stainless steel flats that had small, central, through-holes drilled in the surfaces. In operation, a 24- μ liter drop of oil was pumped up through the hole. As the drop reached the surface, cinematographic records of the wetting and spreading of the drop were recorded. The SRG-10 instrument oil showed the same rate of spreading regardless of the surface finish of the 440C flats. Use of a barrier film prevented the oil from spreading beyond a predetermined radius. An oblique mirror mounted beside each flat showed that the drop of oil on the flat with the barrier film was roughly hemispherical. It was concluded that: 1) SRG-10 did wet and spread on the 440C surfaces; 2) the rate of advance was slower than had been anticipated; 3) the barrier film was very effective in confining this oil. Some data was lost because of a milli-g acceleration disturbance. Analysis of other fluid wetting data was done at Goddard Space Flight Center, but was never published. Nevertheless, useful lessons were learned about the problems of doing experiments in space. It should be anticipated that some new experiments will have to be run in the future.

A possible key to the problem of understanding wicking or spreading in space is to hold firmly to the idea that differences between space and earth are differences in degree rather than in kind. Objects in space are subjected to some gravitational pull, but it is just much smaller that it is on earth. Extrapolation or interpolation of data may provide useful guidelines.

3.1.3.2 Detecting Oil Films by Fluorescence. A technique which shows promise in studies of wetting and spreading is the use of a fluorescence indicator dissolved in the oil. This technique was used by Messina^[85] at the Bell Laboratories to detect contaminant films on electrical contacts. One particularly promising compound: 2,5-bis (5-tert-butyl-2-benzoxazolyl) thiophene, (BBOT), showed the most promise. Only 0.1wt% of BBOT is needed, and this amount is easily dissolved in oil, even in the perfluorinated oils. It fluoresces strongly in ultraviolet light. The author's work suggests that fluorescent techniques can be used to measure film thickness (by intensity) as well as to determine the distribution of lubricant. Using a computer-controlled photoncounting spectrofluorimeter, quantitative measurements can be obtained. This would be a good technique to evaluate dewetting.

Tanimoto and Rabinowicz^[86] also used this compound to measure the thickness of perfluorinatedpolyether oil films on hard magnetic discs.

3.1.3.3 Establishing Practical Evaporation Rates. All practical lubricants contain at least a narrow cut of molecules with different chain lengths and a range of vapor pressures. Consider the example of a rotating shaft mounted on oil-lubricated ball bearings and positioned inside a container. At one point, the shaft penetrates the container through a tight tolerance labyrinth seal. This is the only access to the outside. The container itself is in a hard vacuum environment. During the test, the shaft should be rotating at low speed to keep the lubricant moving.

The evaporation of the lubricant will be a turbulent process as molecules of oil and dissolved gases volatilize from the oil. The only real avenue of escape is through the labyrinth seal. Because of the number of molecular collisions, this first stage of evaporation probably helps to keep the pressure in the enclosure much higher than would be expected. After an indeterminate period of time, which is very dependent on

the temperature inside the container and the pressure that exists outside the enclosure, the first stage of evaporation will be essentially complete.

At that point in time, the rate of evaporation will have decreased markedly. Migration of the oil along the shaft and through the labyrinth seal could result in more evaporation losses, but this can be minimized by using a non-wetting barrier film to keep the oil from reaching the seal area. To simulate these evaporation conditions, a test fixture should be constructed as described above. Figure 3-5 is a schematic of the fixture.

Cryogenically cooled baffles would be placed in front of the labyrinth seal opening to simulate the hard vacuum of space. In this way, any volatile matter that escaped through the seal would be condensed and immobilized on the baffle. The test apparatus would be made so that the baffle and the ball bearing shaft, with the bearings, could be removed easily from the container for weighing and examination.

Accelerated tests could be run by taking advantage of the rule of thumb that the evaporation rate will increase tenfold for each 10% rise in the absolute temperature. As long as the temperature does not cause any degradation of the lubricant, this is a valid way to obtain data.

3.1.3.4 Model of Significance of Lubricating Regimes. Figure 3-6 shows the effect of operating parameters on the types of lubrication that could be encountered in service. Bearings operating in the boundary regime are subject to wear even if plenty of oil is present. Mild adhesive wear would be normal with compatible material combinations, but galling and seizure can occur with other materials. When there is a transition to the "mixed lubrication" regime, partial EHD films support some of the load and wear is generally reduced, but not eliminated. Finally, in the hydrodynamic region the surfaces are supported on fluid films and wear is presumed to be nil. Each of these lubrication regimes is normally treated as a separate case, but recent modeling work by Heshmat et al.^[67] has resulted in the hypothesis that there is a common tribological mechanism that exists between interacting surfaces.

These authors have presented experimental evidence supporting their contention that both morphological and hydrodynamic effects are involved, regardless of the particular lubrication regime, and that differences in the mode of lubrication are differences in degree rather than in kind. The tribological regimes do not have rigid boundaries that mark the transition from one regime to the next. This is apparent when a bearing is passing from, say, boundary lubrication into the mixed region. Morphological effects are predominant in boundary lubrication, but most investigators agree that EHD lubrication, at least on a micro-scale, is also involved.

As the bearing develops an EHD film, the physical and chemical properties of the surfaces do not fade into the background; they still play an important role in maintaining the EHD film. The transition from the EHD mixed film to hydrodynamic lubrication seems to downplay the importance of the morphology of the surfaces, as shown in Figure 3-7, but this may be more apparent than real. Oil film thicknesses, 0.08 mm or less, would be typical. Asperity interactions, or wear particles trapped between the

* The term "Morphology" refers to a variety of characteristics including: elastic, plastic, chemical, molecular and other surface phenomena in the contact zone.

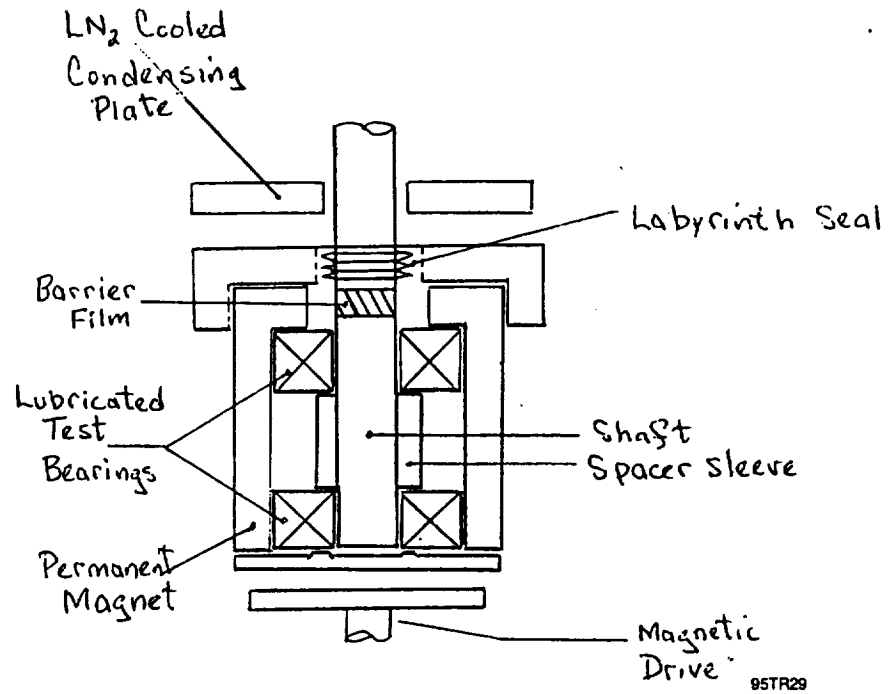

Figure 3-5. Cage Friction Test Geometry. From [93].

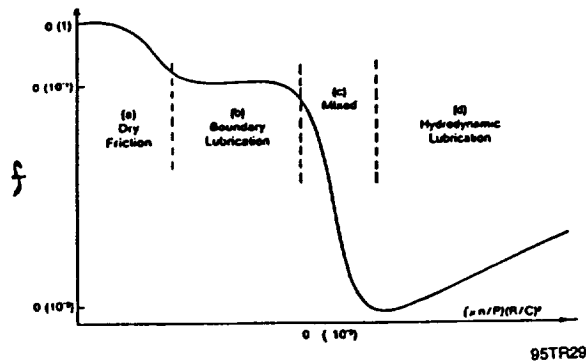

Figure 3-6. Tribological Regimes. From [97].

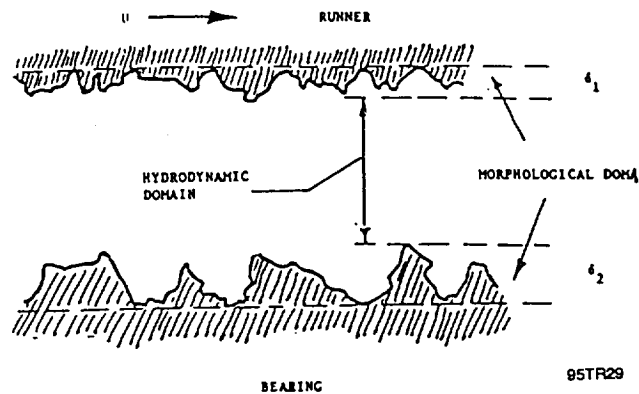

Figure 3-7. The Two Domains in a Full Hydrodynamic Film. From [87].

surfaces, could have morphological consequences. Elastic deformation of the surfaces through these oil films is feasible. Chemical reactions at the surfaces could result in localized changes in oil properties.

In their hypothesis, the authors do not treat the unlubricated case as being truly "dry". They regard oxide films, and other inorganic or organic layers, as well as any wear particles trapped between the surfaces, as being potential lubricants, and they cite the results of a number of studies which have shown that loose particles can support a load and behave as a solid lubricant film^[75, 76].

The authors sum up their findings as evidence that the entire range of tribological regimes from dry surfaces to thick fluid film lubrication involve both morphological and hydrodynamic effects which provide the necessary load-carrying capacity. It is a shift in their relative ratios that defines the lubrication regime. This is shown schematically in Figure 3-8.

The contribution of the morphological effect is thus dependent on the magnitude of the film thickness, as depicted in Figure 3-8. The percentages at either end, and the shape of the line delineating the morphological and hydrodynamic components, were picked completely at random. The task of tribology, therefore, is to devise a set of linked constitutive equations which, when solved, would reflect the combined effects of both components. This equation combines hydrodynamic, chemical and morphological effects in a bearing in the form of:

$$W_T = W_H + W_M + W_C$$

where the first term W_H contains fluid film quantities, the second, W_M , represents morphological quantities and the third, W_C , chemical, with the domains where either W_H , W_M , and W_C applies, to be determined as part of the solution. Conceptually, a similar set of expressions containing some modified Reynolds equation and an appropriate morphological and chemical equation would have to be formulated, which would yield the proper solution for any of the regimes portrayed in Figure 3-6.

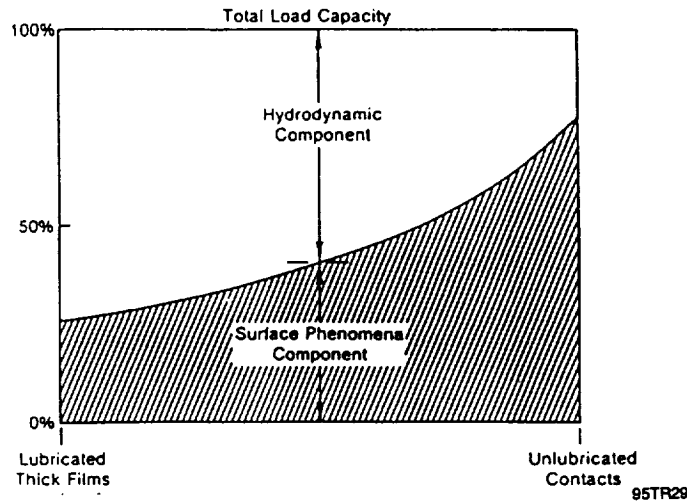

Figure 3-8. The Weights of Morphological and Hydrodynamic Components in Tribological Processes. From [87].

Heshmat^[77] also researched the problem of starved bearing technology, which is a major problem in both slowly rotating (DMA) and high-speed ball bearings, such as momentum wheel bearings. Figure 3-9 illustrates the effect of side flow and end flow on the performance of a hydrodynamic journal bearing. End flow (\bar{Q}_2) from a starved bearing becomes significant first, but the decrease is gradual. There is a strong inverse relationship between the end flow and the temperature rise, indicating that the drop in viscosity is largely responsible for the losses. In contrast, side flow is linear and contributes more to bearing starvation.

Figure 3-10 shows that the power loss decreases with the degree of starvation because the increase in oil temperature causes a drop in viscosity. At some point when the bearing is operating on a very marginal film, the power loss begins to increase sharply. This point coincides with the sudden increase in temperature shown in Figure 3-9.

Figure 3-11 shows the pressure profile as a function of degrees of starvation. As the inlet flow is reduced, the pressure profile becomes much steeper. If film thicknesses were being measured on starved bearings, these pressure profiles would be very deceptive since they would indicate that the oil film was much thicker with a starved bearing. It would be, but the edges of the contact area would be essentially unprotected.

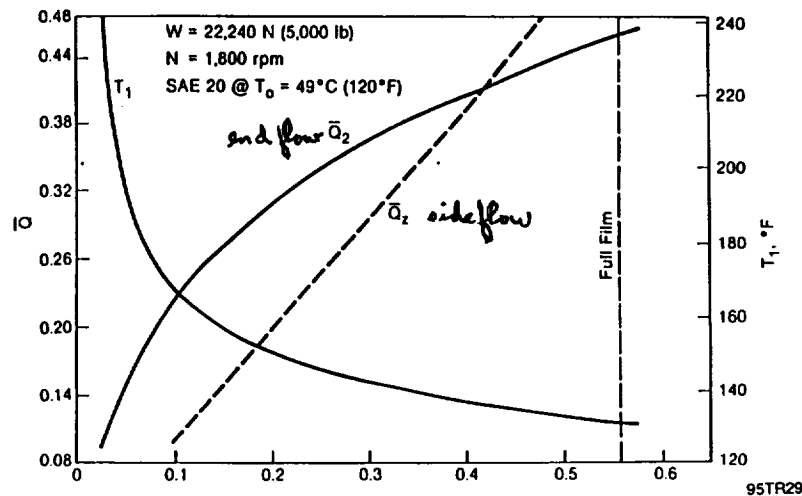

Figure 3-9. Theoretical Values of Q_2 and T_1 in Starved Bearings. From [90].

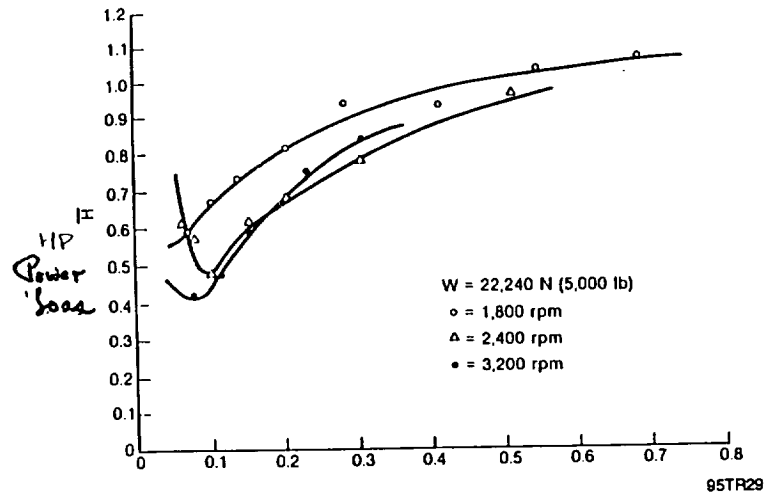

Figure 3-10. Power Loss as a Function of Degree of Starvation, $D = 5.51$ in. From [10].

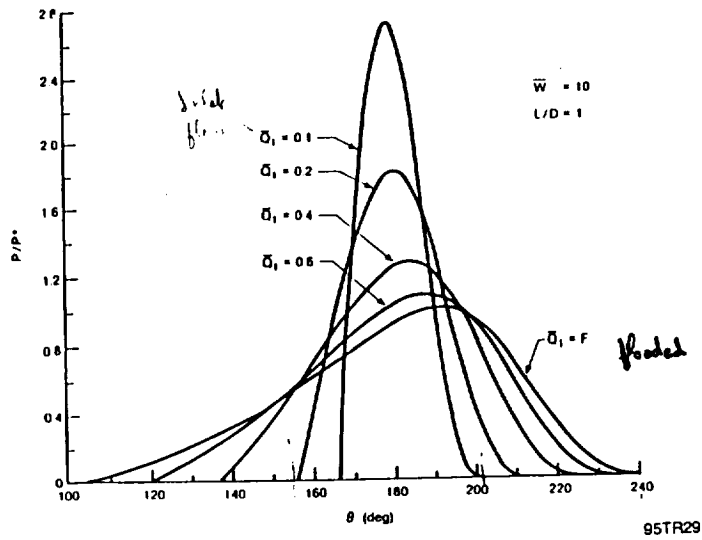

Figure 3-11. Pressure Profile at Bearing Midplane for Various Degrees of Starvation. From [10].

4.0 CONSTRUCTION OF A DEMONSTRATION PROGRAM (TASK VII)

The scope of this task was defined as follows ^[1]:

"Based on the results of the accelerated testing technology "roadmap" study, a space mechanism mechanical system or component should be selected to demonstrate that the methods developed will adequately predict the life and/or performance of a mechanism. A plan should be presented for demonstrating the accelerated methods including experimental equipment, test procedure, time guideline and cost analysis."

The backbone of this recommended work is the use of sensors to monitor the performance of hardware. This is the key to accelerated testing, being able to sense and trend the performance of mechanical components or systems.

To supplement the findings, additional studies are needed to determine how the lubricant can be stored and metered to the bearings in a timely manner. The use of porous plastic retainers and their ability to supply oil is one facet of the problem. The wetting and spreading behavior and evaporation rates of the candidate oils is another. Techniques which influence the direction of lubricant flow (e.g., temperature differentials) should also be investigated.

The physical and chemical properties of candidate retainer materials, and their effect on friction and wear, deserve more attention. Kissel et al. ^[93] showed a strong effect of elastic modulus on the friction of oil-lubricated porous polyimide, but not on a laminated phenolic. The damping characteristics of the retainer material could also have a pronounced effect on retainer stability.

Finally, there is a need for more careful evaluations of oil loss by evaporation in the microgravity environment. Temperature can be used to accelerate oil loss if condensing surfaces are used to trap the oil vapor that escapes from the enclosure or container.

The following paragraphs discuss the approaches briefly.

4.1 Diagnostics

The types of monitoring sensors to be considered include:

- Sound and vibration
- Electrical contact resistance
- Torque
- Temperature
- Other candidates and overlapping trend signals.

The goal is to model both the signal and the cause of the signal.

Various test conditions including starved lubrication, particle contamination, raceway flaws, etc., should be evaluated to determine how these would affect sensor output signals. Starved lubrication is probably of the greatest significance. By dissolving the lubricant in a volatile solvent, such as hexane, and then monitoring bearing performance as the solvent evaporates, a picture of the effect of oil starvation could be obtained. Sound, vibration and electrical contact resistance should be monitored.

For this work, it is recommended that a relatively simple test mechanism be used. For example, it could be a hollow steel shaft supported by two preloaded angular-contact bearings. Slip rings could be used to monitor electrical signals. Provision should be made to rotate either the inner or outer bearing race.

The initial evaluation of sensors and the test rig should be done in the laboratory environment, perhaps with dry air or dry argon. This is essential; trying to evaluate instrumentation in a vacuum would be very counterproductive. In addition, the instrumentation will be subjected to ground tests and must perform just as well then, as in space.

Prior to assembly, each bearing should be thrust loaded and evaluated individually on a single vertical pedestal shaft to acquire a set of signature traces that can be used to evaluate before and after behavior. This procedure would also serve as a quality control check. The literature describes examples of test bearings that were found to be faulty.

4.2 Lubricant Supply

In every list of potential failure modes, lubricant deflection is always chosen as one of the leading causes of failure. A variety of reasons, such as nonwetting or dewetting, evaporation, or decomposition may be the specific problem; however, loss of lubricant can be the cause of failure, whatever the reason. Models are needed to predict the flow paths of lubricants. Currently, there is very little information in the literature that can be used to design lubricant supply systems. Porous retainers and porous reservoirs are impregnated with lubricant to act as additional supplies of oil, but there is contradictory evidence about their performance (e.g., ^[91, 92]).

Diagnostics should be capable of detecting changes in the lubricant and its supply. Simple experiments with the fluorescent indicator described in Section 3.1.3.2 will be run to determine nonwetting or dewetting. Infrared spectroscopy and ferrography will be used to determine the condition of the lubricants.

4.3 Retainer Materials

The composition of ball bearing retainers is also a controversial subject. Porous laminated phenolics, porous polyimides and porous nylon appear to be the leading candidates, but no one is looking at the overall problems of cage instability and the physical properties of the materials, particularly damping characteristics and dry sliding performance.

Evaluations of candidate retainer materials could be performed on a simple test rig such as the one shown in Figure 4-1. This rig was used by Kissel et al. ^[93] for retainer material studies. With some small changes, it could also be used to evaluate damping effects.

4.4 Evaporation Rates of Oils

Practical lubricants contain molecules which differ in molecular weight, vapor pressure, and surface tension. During initial exposure to vacuum, light fractions, dissolved gases and dissolved water will be stripped away. When these have evaporated, both the vapor pressure and the evaporation rate will decrease markedly. In Section 3.1.3.3 of this report, a test apparatus for evaluating the long-term evaporation rate is described. To accelerate the results, three temperature levels could be evaluated, 293 K (20°C),

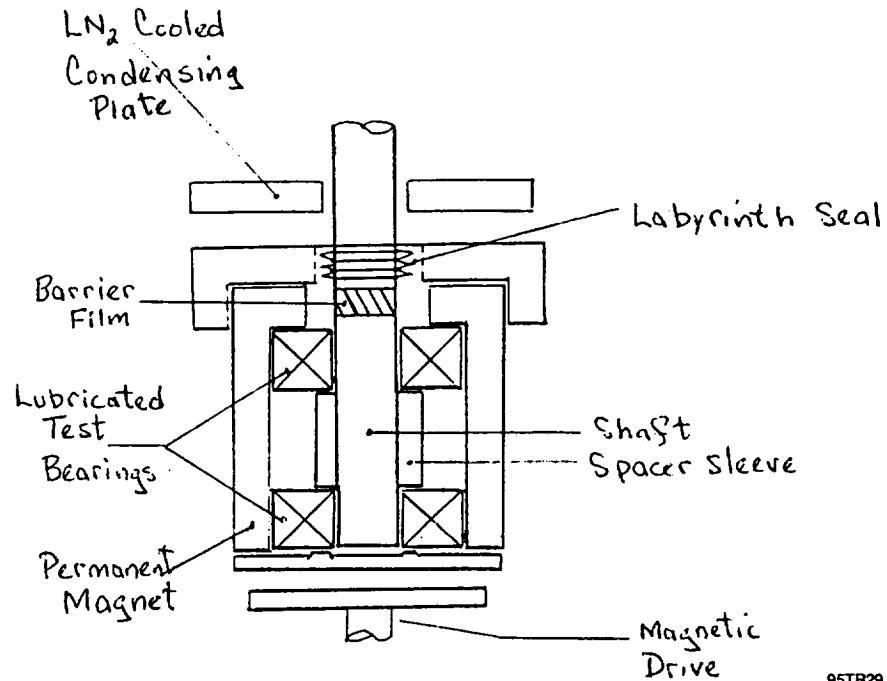

95TR29

Figure 4-1. Cage-Friction Test Geometry. From [63].

322 K (49°C) and 354 K (81°C). Each 10% increase in the absolute temperature should increase the evaporation rate roughly tenfold. Three different test oils could be evaluated: Bray 815Z, SRG80 mineral oil, and a PAO-type synthetic hydrocarbon.

4.5 Item of Work vs. Time Required

Table 4-1 is a summary of the tasks and manpower estimates that are being recommended to accomplish the Demonstration Program. If possible, the initial task, Selection and Evaluation of Computer Programs, should be done by someone who is familiar with the problems encountered in the space program and who has demonstrated capabilities in the analysis of rolling contact bearings and retainer interactions. Throughout the rest of the program, there should continue to be close interaction between the person responsible for the computer programs and the person responsible for the other tasks. One specific problem is retainer design. Why select a ball-guided retainer instead of a land-guided retainer?

Whenever bearing tests are to be run to establish performance under accelerated test conditions, a test matrix plan, similar to the one used by Meeks [62], should be followed. This matrix should be based on the possible failure modes and would include the following variables: speed, load, temperature, class and quantity of lubricant. The matrix used by Meeks is shown in Figure 2-9 of this report. It consists of tests at three levels of severity, one at the anticipated operating conditions and the other two at levels above and below the anticipated conditions. This matrix approach has been used successfully by others in evaluating solid lubricants, etc. The results will indicate if there is a marked change in the failure mode which would show a need to reduce the severity of the operating conditions or to change the design.

Table 4-1. Estimated Man-Months and Material Costs to Complete the Demonstration Program.

Task	Estimated Man-Months	Elapsed Time	Material Costs ^(a)
A. Selection and Evaluation of Computer Programs	5	1st year	—
B. Selection and Evaluation of Sensors	10	1st year	Estimate \$40K for sensors, test stand and bearings. Most evaluations will be run in dry air or argon.
C. Effect of Microgravity on Flow Paths - Experiment and Modeling	8	1st year	About \$10K for materials. Evaluations in air and vacuum.
D. Lubricant Loss by Evaporation	4	~2 years ^(b)	Test rig, bearings and lubricants \$15K, liquid nitrogen \$2.5K
E. Interim and Final Reports	2	1½ years ^(b)	—

95TR29

(a) Does not include costs for vacuum systems (about \$70,000.00 per system).

(b) Last section of Final Report must be furnished after evaporation tests are concluded.

5.0 REFERENCES

1. Heshmat, H., "Accelerated Testing of Mechanisms" Letter report, 17 May 1994, report summarizing Space Mechanisms Workshop held at NASA/LeRC.
2. Todd, M.J., "Solid Lubrication of Ball Bearings for Spacecraft Mechanisms", *Tribology Intern.*, 15, No. 6 (1982), pp. 331-338.
3. Atlee, Z.J., Wilson, J.T. and Filmer, J.C., "Lubrication in Vacuum by Vaporized Thin Metallic Films", *Journal of Applied Physics*, 11, September 1940, pp. 611-615.
4. Evans, H.E., and Flatley, T.W., "Bearings for Vacuum Operation-Retainer Material and Design", ASME Paper 62-Av-11. 1962 ASME Aviation Conference.
5. Flatley, T.W., "High-Speed Vacuum Performance of Miniature Ball Bearings Lubricated with Combinations of Barium, Gold, and Silver Films", NASA TN D-2304, June 1964.
6. Harris, C.L., and Warwick, M.G., "Lubrication of Bearings and Gears for Operation in a Space Environment", *Proc. Instn. of Mech. Engineers*, 183, Pt. 31 (1968-69), pp. 39-49.
7. Christy, R.I., "Dry Lubrication for Rolling Element Spacecraft Parts", *Tribology Intern.* 15, No. 5 (1982), pp. 265-271.
8. Spalvins, T., "Lubrication with Sputtered MoS₂ Films", *ASLE Trans.* 14, No. 4, (1971), pp. 267-274.
9. Christy, R.I., and Barnett, G.C., "Sputtered MoS₂ Lubrication System for Spacecraft Gimbal Bearings", *Lubr. Engineering*, 34, No. 8 (1978), pp. 437-443.
10. Roberts, E.W., and Price, W.B., "In-Vacuo Tribological Properties of High-Rate Sputtered MoS₂ Applied to Metal and Ceramic Substrate", *Mat'ls. Res. Soc. Symp. Proc.* 140 (1989), pp. 251-264.
11. Todd, M.J. and Bentall, R.H., "Lead Film Lubrication in Vacuum", *ASLE Proceedings -2nd Intern. Conf. on Solid Lubrication*, Denver, CO., Aug. 15-18, 1978. ASLE SP-6, pp. 148-157.
12. Kobs, K., Dimigrn, H., Hubach, H., Tolle, H.J., Leutenecker, R. and Ryssel, H., "Enhanced Endurance Life of Sputtered MoS₂ Films on Steel by Ion Beam Mixing", *Mat'ls. Science and Engineering* 90 (1987), pp. 281-286.
13. Gerkema, J., "Lead Thin Film Lubrication", *Wear* 102 (1985), pp. 252.
14. Roberts, E.W., "Thin Solid Lubricant Films in Space", *Tribology Intern.*, 23, No. 2 (1990), pp. 95-104.
15. Boving, H.J. and Hintemann, H.E., "Wear Resistant Hard Titanium Carbide Coatings for Space Applications", *Tribology Intern.* 23, No. 2 (1990), pp. 129-134.
16. Roberts, E.W., "The Tribology of Sputtered Molybdenum Disulfide Films", *Proc. I Mech. E., Tribology - Friction, Lubrication and Wear, Fifty Years On*, London, July 1987, pp. 503-510.

17. Leger, L.J. and Dufrane, K., "Space Station Lubrication Considerations", 21st Aeronautical Mechanism Symp., Johnson Space Center, May 1987 N87-29858.
18. Young, W.C., Clauss, F.J. and Drake, S.P., "Lubrication of Ball Bearings for Space Applications", ASLE Trans., 6 (1963), p. 178-191.
19. Bowen, P.H., "Solid Lubrication of Gears and Bearings in a Space Environment", ASLE Trans. 7 (1964), pp. 227-235.
20. Smith, G.R. and Vest, C.E., "Lubrication of Spacecraft Mechanism Using the Transfer Film Technique", Lubr. Engineering, 27, No. 12 (1971), pp. 422-427.
21. Vest, C.E., and Ward, B.W., "Evaluation of Space Lubricants Under Oscillatory and Slow Speed Rotary Motion", Lubr. Engineering, 24, No. 4 (1968), pp. 163-172.
22. Stevens, K.T. and Todd, M.J., "Parametric Study of Solid Lubricant Composites as Ball Bearing Cages", Tribology Intern. 15, No. 5, (1982), pp. 293-302.
23. Rowntree, R.A. and Todd, M.J., "A Review of European Trends in Space Tribology and Its Application to Spacecraft Design". Mat'ls Res. Soc. Symp. Proc. 140, (1989), pp. 21-34.
24. Federline, M.F. and Vest, C.E., "Operating Gears in a Simulated Space Environment", Lubr. Engrg. 23, No. 4 (1967), pp. 134-144.
25. Harris, C.L. and Wyn-Roberts, D., "Friction and Wear Studies in Ultra-High Vacuum and the Evaluation of Electrical Slip Rings", Proc. Instn. Mech. Engrs. 183, Pt. 31 (1968-69), pp. 50-60.
26. Fusaro, R.L., "Self-Lubricating Polymer Composites and Polymer Transfer Film Lubrication for Space Applications", Tribology Intern. 23, No. 2 (1990), pp. 105-122.
27. Briscoe, H.M. and Todd, M.J., "Considerations on the Lubrication of Spacecraft Mechanisms". Proc. 17th Aerospace Mechanisms Symp. NASA Conf. Paper CP-2273 (1983), pp. 19-37.
28. Auer, W., "A Family of BAPTAS for Geo and Leo Applications", 23rd Aerospace Mechanisms Symp. NASA/MSFC 1989 NASA Conference Publication 3032, NTIS No. N89-23892.
29. Fleischauer, P.D. and Hilton, M.R., "Assessment of the Tribological Requirements of Advanced Spacecraft Mechanisms". Mat'ls. Research Soc. Symp. Proc. 140 (1989), pp. 9-20.
30. Phinney, D.D., "Slip Ring Experience in Long Duration Space Applications", 20th Aerospace Mechanisms Symp. NASA Conference Publ. 2423. Lewis Research Center, Cleveland, Ohio, May 7-9, 1986, pp. 45-54.
31. Smith, D.W., "Signal and Power Roll Ring Testing Update", 23rd Aerospace Mechanisms Symp. NASA/MSFC 1989. NASA Conf. Publ. 3032, NTIS No. N-89-23892.
32. Devine, E.J., "Rolling Element Slip Rings for Vacuum Application". NASA TN D-2261, April 1964.
33. Zaretsky, E.V., "Liquid Lubrication in Space", Trib. Intern. 23, No. 2 (1990), pp. 75-93.

34. Hilton, M.R. and Fleischauer, P.D., "Lubricants for High-Vacuum Applications", ASM Handbook Vol. 18, Friction, Lubrication and Wear Technology (1992), Amer. Soc. for Metals, Metals Park, Ohio 44073, pp. 150-161.
35. Lewis, P., Murray S.F., Peterson, M.B., and Esten, H., "Lubricant Evaluation for Bearing Systems Operating in Spatial Environments". ASLE Trans. 6, No. 1 (1963), pp. 67-79.
36. Carre, D.J., "Perfluoropolyalkylether Oil Degradation: Inference of FeF₃ Formation on Steel Surfaces Under Boundary Conditions", ASLE Trans. 29, No. 2 (1986), pp. 121-125.
37. Strom, B.D., Bogy, D.B., Walmsley, R.G., Brandt, J. and Bhatia, C.S., "Gaseous Wear Products from Perfluoropolyether Lubricant Films". Wear, 168 (1993), pp. 31-36.
38. Mori, S. and Morales, W., "Decomposition of Perfluoroalkylpolyethers (PFPE) in Ultra-High Vacuum Under Sliding Conditions". Tribology Trans. 33, No. 3 (1990), pp. 325-332.
39. Sharma, S.K., Snyder, C.E., and Gschwender, L.J., "Tribological Behavior of Some Candidate Advanced Space Lubricants", Tribology Trans. 36 No. 2, pp. 321-325.
40. Lacey, I.N., Kelsall, G.H., Spikes, H.A. and Mackpherson, P.B., "Thick Antiwear Films in Elastohydrodynamic Contacts". Part I: Film Growth in Rolling/Sliding EHD Contacts". ASLE Trans. 29, No. 3 (1986), pp. 299-305.
41. Ibid, "Part II: Chemical Nature of the Deposited Films". ASLE Trans. 29, No. 3 (1986), pp. 306-311.
42. Young, W.C. and Clauss, F.J., "Lubrication for Spacecraft Applications", Lubr. Engrg. 22 No. 6 (1966), pp. 219-227.
43. Purdy, W. and McCrown, W., "Practical Experience With Worm Gearing for Spacecraft Power Transmission Application". 23 Aerospace Mechanisms Conf. NASA/MSFC, May 1989 N-89-23892.
44. Pacholke, P.J. and Marshek, K.M., "Improved Worm Gear Performance With Colloidal Molybdenum Disulfide Containing Lubricants". Lubr. Engrg. 43 No. 8 (1987), pp. 623-628.
45. Hare, E.F. and Zisman, W.A., "Autophobic Liquids and The Properties of Their Adsorbed Films". J. Physical Chem. 59, April 1955, pp. 335-340.
46. Scriven, L.E. and Sternling, C.V., "The Marangoni Effects", Nature 187, July 1960, pp. 186-188.
47. Kinzig, B.J. and Rauner, H., "Problems Encountered With Antistatic Packaging for Miniature Bearings", Lubr. Engrg. 36 No. 4 (1980), pp. 219-225.
48. Bennett, M.K. and Ravner, H., "Antistatic Agents, Lubricants and Precision Bearings", Lubr. Engrg. 38, No. 8 (1982), pp. 481-486.
49. Benzing, R.J. and Strang, J.R., "Failure Mode Analysis of Lubricated Satellite Components", Technical Report AFML-TR-73-188 May 1974. Request from Air Force Mat'ls. Lab, Nonmetallic Mat'ls. Div., Lubricants and Tribology Branch, AFML/MBT, W-P Air Force Base, Ohio 45433.

50. Kannel, J.W. and Dufrane, K.F., "Rolling Element Bearings in Space", 20th Aerospace Mechanisms Symposium, Lewis Research Center, Cleveland, Ohio, May 7-9, 1986, pp. 121-132, NASA CP24223.
51. Holzhauser, W. and Calabrese, S.J., "Steel Hardness Effects in Boundary Lubricated Sliding: An In-Situ SEM Study Tribology Trans. 33 No. 1 (1990), pp. 1-10.
52. Gardos, M.N., "Labyrinth Sealing of Aerospace Mechanisms - Theory and Practice", ASLE Trans. 17, No. 4 (1974), pp. 237-250.
53. Kinzig, B.J. and Ravner, H., "Factors Contributing to the Properties of Fluoropolymer Barrier Films", ASLE Trans. 21, No. 4 (1978), pp. 291-298.
54. Kingsbury, E., "Large Bearing Operation Without Retainer", Lubr. Engrg. 35, No. 9 (1979), pp. 517-520.
55. Bertrand, P.A., "Oil Absorption into Cotton-Phenolic Material", J. Mater. Research, Vol. 8 No. 7, July 1993, pp. 1749-1757.
56. O'Donnell, P.J. and Warwick, M.G., "Peak Friction Levels in Low Speed Rolling and Sliding Contacts and Their Influence on the Performance of Spacecraft Mechanisms". I. Mech. E First European Tribology Congress, London, 1973, pp. 343-352. Mech. Engrg. Publ., N.Y. (1975).
57. Boesiger, E.A. and Warner, M.H., "Spin Bearing Retainer Design Optimization", 25th Aerospace Mechanisms Symp. J.P.L. May 1991, NASA Conf. Publ. 3113.
58. Phinney, D.D., Pollard, C.L. and Hinricks, J.T., "Experience with Duplex Bearings in Narrow Angle Oscillating Applications". 22nd Aerospace Mechanism Symp. NASA Langley Research Center, May 1988. NASA Conf. Publ. 2506 (pp. 211-226) NTIS N88-21468.
59. Bohner, J.J. and Conley, P.L., "On the Torque and Wear Behavior of Selected Thin Film MoS₂ Lubricated Gimbal Bearings". 22nd Aerospace Mechanism Symp. Loc. Cit. (ref. 57) pp. 227-244.
60. Todd, M.J., "Modelling of Ball Bearings in Spacecraft", Tribology Intern. Vol. 23, No. 2 (1990) pp. 123-128.
61. Loewenthal, S.H., "Two Gimbal Bearing Case Studies: Some Lessons Learned". 22nd Aerospace Mechanisms Symp. Loc. Cit. (ref. 57) pp. 253-269.
62. Meeks, C.R., "Accelerated Testing of Ball Bearings", Lubr. Engrg. Vol. 28, No. 10 (1972) pp. 373-378.
63. Harris, T.A., Rolling Bearing Analysis, John Wiley and Sons, 1966, pp. 318-319.
64. Smith, R.L. and McGrew, J.M., "Failure Modes and Accelerated Life Test Methods for Despun Antenna Bearings", Lubr. Engrg., Vol. 30, No. 1 (1974) pp. 17-26.
65. Kingsbury, E., "Torque Variations in Instrument Ball Bearings", ASLE Trans. 8, No. 4 (1965) pp. 435-442.
66. Tyler, J.C., Carper, H.J. and Ku, P.M., "EHD Film Thickness Behavior in DMA Bearings. Part I - Experimental and Computational Techniques". ASLE Trans. Vol. 22, No. 3 (1979) pp. 201-212.
67. Tyler, J.C., Carper, H.J. and Ku, P.M. Ibid, Loc Cit. (ref. 66) pp. 213-219.

68. Ward, W.E., "Analysis of a Set of Failed Accelerated Life Test DMA Bearings", ASLE Trans. Vol. 22, No. 2 (1979) pp. 193-199.
69. Ward, W.E., "Preparation of DMA Bearings for Accelerated Life Prediction Studies". Lubr. Engrg. Vol. 35, No. 1 (1979) pp. 17-24, 33-35.
70. Babecki, A.J., "Quality Features of Spacecraft Ball Bearing Systems", Materials Technology Report MTR No. 755-013, December 1975. Materials Engrg. Branch. NASA Goddard Space Flight Center, Greenbelt, MD.
71. Davis, H.W., Ahlborn, G.H., and Lewis, R.A. "Validation of Life Prediction Techniques for DMA Bearings and Slip Rings." AFWAL-TR-85-4007, Final Report for Period September 1981-November 1984 (Limited Distribution).
72. Kingsbury, E. "Large Bearing Operation Without a Retainer." Lubrication Engineering Vol. 35, No. 9 (1979) pp. 517-520.
73. Todd, M.J. and Parker, K. "GIOTTO's Antenna De-Spin Mechanism: Its Lubrication and Thermal Vacuum Performance." 21st Aerospace Mechanisms Symposium Johnson Space Center, May 1987 (p. 295) NTIS N87-29858.
74. Freeman, A.P. "Gyro Ball Bearings - Technology Today" presented at the 6th AGARD Guidance and Control Meeting, "Inertial Navigation: Components" at Braunschweig, Germany 7-9 May 1968.
75. Smith, R.L. "Rolling Element Bearing Diagnostics with Lasers, Microphones and Accelerometers" Presented at 46th Annual Meeting MFPG, Virginia Beach, VA April 1992.
76. Smith R.L. and Walter, T. "Machinery Fault Identification Using Microphones" Vibration Institute 18th Annual Meeting, Hershey, PA June 20-23, 1994.
77. Furey, M.J. "Metallic Contact and Friction Between Sliding Surfaces" ASLE Trans. Vol. 4, No. 1 (1961) pp. 1-11.
78. Chu P.S.Y. and Cameron, A. "Flow of Electrical Current Through Lubri-Contacts" ASLE Trans. Vol. 10, No. 3 (1967) pp. 226-234.
79. Smith, R.L. "Bearing Contact Resistance as a Diagnostic Aid" Presented at 22nd Annual Meeting MFPG, Anaheim, CA April 23, 1975.
80. Bolzio, T.H. and Murray, S.F. "Contact Resistance Measurements for Observation of Fluid Film Effects in Journal Bearings" ASLE Trans. Vol. 22, No. 3 (1979) pp. 220-226.
81. Perrotto, J.A., Riano, R.R.I and Murray, S.F. "Effect of Abrasive Contamination on Ball Bearing Performance" Lubrication Engineering Vol. 35, No. 12 (1979) pp. 698-705.
82. Skylab, Classroom in Space, Ed. by Lee B. Summerlin NASA SP-401. 1977.
83. Apollo-Soyuz "Experiments in Space" Pamphlets 2 and 6 October 1977 NASA, Washington D.C.
84. Pan C.H.T., Gause, R.L. and Whitaker, A.F. "Tribology Experiment in Zero Gravity" Science, Vol. 225, 13 July 1984 pp. 202-203.
85. Messina, F.D. "Fluorescence Detection of Thin Film Electrical Contact Lubricants". ASLE Trans. Vol. 27, No. (199) pp. 237-242.

86. Tanimoto, K. and Rabinowicz, E. "A Fluorescence Technique for Measuring Lubricant Thickness on Hard Magnetic Disks" *Tribology Trans.* Vol. 35, No. 3 (1992) pp. 537-543.
87. Heshmat, H. Pinkus, O. and Godet, M. "On a Common Tribological Mechanism Between Interacting Surfaces" *Tribology Trans.* Vol. 32, No. 1 (1989) pp. 32-41.
88. Heshmat, H. "The Quasi-Hydrodynamic Mechanism of Powder Lubrication -- Part I: Lubricant Flow Visualization." *Lubrication Engineering*, Vol. 48, No. 2 (February 1992) pp. 96-104.
89. Heshmat, H. "The Quasi-Hydrodynamic Mechanism of Powder Lubrication -- Part II: Lubricant Film Pressure Profile." *Lubrication Engineering* Vol. 48, No. 5 (1992) pp. 373-383.
90. Heshmat, H. "Starved Bearing Technology: Theory and Experiment." Ph.D. Thesis, Mechanical Engineering Department, Rensselaer Polytechnic Institute, Troy, New York, December 1988.
91. Liu, J., Fan, Y. and Wen, S. "An Experimental Study on Oil Supply in a Space Bearing with an Oil-Impregnated Retainer." *Wear* Vol. 165 (1993) pp. 193-196.
92. Bertrand, P.A., Carré, D.J. and Bauer, R. "Oil Exchange Between Ball Bearings and Cotton-Phenolic Ball-Bearing Retainers." *Tribology Trans.* Vol. 38, No. 2 (1995) pp. 342-352.
93. Kissel, J.W. and Snediker, D.K. "A Study of the Friction Characteristics of Some Porous Bearing Cage Materials." *ASLE Trans.* Vol. 21, No. 4 (1978) pp. 307-314.

REPORT DOCUMENTATION PAGE

Form Approved
OMB No. 0704-0188

Public reporting burden for this collection of information is estimated to average 1 hour per response, including the time for reviewing instructions, searching existing data sources, gathering and maintaining the data needed, and completing and reviewing the collection of information. Send comments regarding this burden estimate or any other aspect of this collection of information, including suggestions for reducing this burden, to Washington Headquarters Services, Directorate for Information Operations and Reports, 1215 Jefferson Davis Highway, Suite 1204, Arlington, VA 22202-4302, and to the Office of Management and Budget, Paperwork Reduction Project (0704-0188), Washington, DC 20503.

1. AGENCY USE ONLY (Leave blank)	2. REPORT DATE December 1995	3. REPORT TYPE AND DATES COVERED Final Contractor Report	
4. TITLE AND SUBTITLE Accelerated Testing of Space Mechanisms		5. FUNDING NUMBERS WU-323-16-04 C-NAS3-27086	
6. AUTHOR(S) S. Frank Murray and Hooshang Heshmat		8. PERFORMING ORGANIZATION REPORT NUMBER E-10048 MTI-95TR29	
7. PERFORMING ORGANIZATION NAME(S) AND ADDRESS(ES) Mechanical Technology Incorporated Latham, New York		10. SPONSORING/MONITORING AGENCY REPORT NUMBER NASA CR-198437	
9. SPONSORING/MONITORING AGENCY NAME(S) AND ADDRESS(ES) National Aeronautics and Space Administration Lewis Research Center Cleveland, Ohio 44135-3191		11. SUPPLEMENTARY NOTES Project Manager, Robert L. Fusaro, Structures Division, NASA Lewis Research Center, organization code 5230, (216) 433-6080.	
12a. DISTRIBUTION/AVAILABILITY STATEMENT Unclassified - Unlimited Subject Categories 18, 27, and 37 This publication is available from the NASA Center for Aerospace Information, (301) 621-0390.		12b. DISTRIBUTION CODE	
13. ABSTRACT (Maximum 200 words) This report contains a review of various existing life prediction techniques used for a wide range of space mechanisms. Life prediction techniques utilized in other non-space fields such as turbine engine design are also reviewed for applicability to many space mechanism issues. The development of new concepts on how various tribological processes are involved in the life of the complex mechanisms used for space applications are examined. A "roadmap" for the complete implementation of a tribological prediction approach for complex mechanical systems including standard procedures for test planning, analytical models for life prediction and experimental verification of the life prediction and accelerated testing techniques are discussed. A plan is presented to demonstrate a method for predicting the life and/or performance of a selected space mechanism mechanical component.			
14. SUBJECT TERMS Mechanisms; Systems; Tribology; Testing; Space; Mechanical components; Spacecraft components		15. NUMBER OF PAGES 85	
17. SECURITY CLASSIFICATION OF REPORT Unclassified		16. PRICE CODE A05	
18. SECURITY CLASSIFICATION OF THIS PAGE Unclassified	19. SECURITY CLASSIFICATION OF ABSTRACT Unclassified	20. LIMITATION OF ABSTRACT	

