

Acoustic Projector Using Directivity Controllable Parametric Loudspeaker Array

Shigeto Takeoka (1), Yoshio Yamasaki (1)

(1)Faculty of Science and Engineering, Waseda University, Tokyo, Japan

PACS: 43.38.Hz, 43.38.Vk, 43.25.Lj

ABSTRACT

Parametric loudspeakers are known for a very sharp directivity due to their ultrasonic carrier wave. A desired audio signal modulated onto this carrier wave is reproduced along the beam by intrinsic non-linearity of the air. Because of this directivity, parametric speakers provide for distinguished audio applications. In this paper we present our parametric array consisting of 576 ultrasonic transducers controlled individually by using high speed 1-bit signal processing. We are able to control the angle of an audio beam by creating a synthesized surface wavefront. Furthermore, we present an experiment where multiple independent audio beams are emitted from the single parametric loudspeaker.

INTRODUCTION

The parametric loudspeaker that reproduces the sound source by non-linearity of the transmission of modulated ultrasonic wave in the air is known to have a very sharp directivity. The technology is expected to be used for a wide range of applications such as audio listening, announcement systems, and barrier-free systems. In this paper, an array control method for parametric loudspeaker is discussed. We are aiming at the development of the system that applies to a new stereophonic and higher usability system by controlling the angle of multiple independent beams emitted from a single parametric loudspeaker. By controlling 576 ultrasonic transducers individually with high speed 1-bit signal processing, we can adjust the directivity of the ultra-sonic beams. After providing the background, these experiments about directivity control and multiple beam emitting will be presented. And Relationship of the interval of transducers and the sidelobe beams that observed in this experiment will be discussed.

DIRECTIVITY CONTROL USING 1-BIT SIGNAL PROCESSING

Parametric Loudspeaker Arrays

The phenomenon of the nonlinear parametric array interaction is analyzed by Westervelt in 1963[1]. Then about 20 years later, the application of this interaction to the speaker is proposed by Yoneyama et al. [2]. And various proposals like the modulation method have been proposed afterwards. A parametric loudspeaker is usually composed of an array of ceramic transducers with a resonance frequency at the frequency of the carrier wave, emitting a sharp beam of modulated sound. 40kHz~100kHz is used for the carrier frequency because of attenuation by the air. As a basic method, amplitude modulation is used for driving signal of parametric loudspeaker in this paper.

High Speed 1-Bit Signal Processing

In high speed 1-bit signal processing, a signal is quantized with high frequency 1-bit signal as opposed to the commonly used multi-bits. This kind of processing is often used for hi-fidelity system such as Super Audio CD[3]. As the quantization method for generating the 1-bit signal, delta-sigma ($\Delta\Sigma$) modulation is generally used[4]. In this method, the quantization noise is controlled by including the integrator in the feedback loop. Because the spectrum of the modulated signals that drives a parametric loudspeaker is generated around the carrier wave, the $\Delta\Sigma$ modulation of the band-pass type is effective. Eq.(1) shows the transfer function of the quantization noise in the 4th order $\Delta\Sigma$ modulator that is used in the experiments. Fig.1 shows the spectrum of the bitstream itself of the modulated 1-bit signal that entered a 40kHz sine wave that is the resonance frequency of our equipment.

$$H_q(z) = \frac{(1 - 1.968z^{-1} + z^{-2})^2}{(1 - 1.489z^{-1} + 0.5674z^{-2})(1 - 1.651z^{-1} + 0.7833z^{-2})} \quad (1)$$

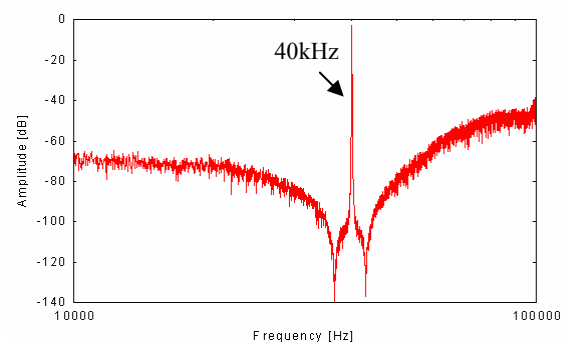

Figure 1. Spectrum of the 1-bit signal including sine wave. The spectrum other than the peak is the quantization noise.

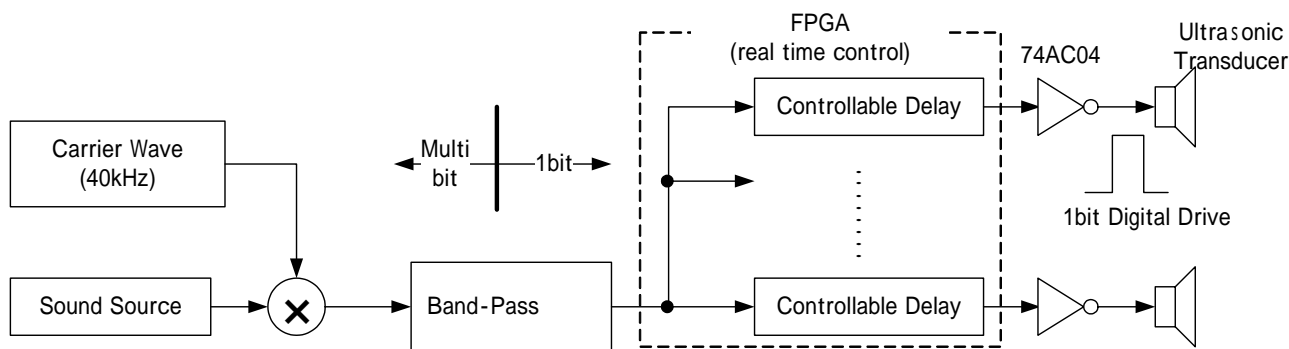

Figure 2. Structure of the 1-bit-controlled parametric transducer array. The sound source is modulated in multi-bit stage and the 1-bit signal is delay-controlled independently in a FPGA. Each ultrasonic transducers are driven with 1-bit signal directly by general purposed logic IC 74AC04.

In this modulator, the signal-to-noise ratio is kept over 100dB at 1.4MHz sampling within 35~45kHz, the range being mainly used in our experiments.

An important characteristic of 1-bit signal processing is that the modulated bitstream itself includes the sound spectrum. Therefore, the 1-bit signal can be used as the driving signal of a class D amplifier. In this experiment, a simple and low power consumption system is realized by using general-purposed logic ICs as D-class amplifiers to drive the large quantity of transducers.

Array control using 1-bit signal processing

The characteristic of high speed 1-bit signal processing allows us to control the direction of sound beams in a simple manner. 1-bit signal processing generally has a MHz class sampling frequency, and it has no need of up-sampling for controlling directivity with enough angle-resolution by a simple delay control. Fig. 2 shows the structure of the system used in this experiment. Our system operates at a sampling frequency of 1.4MHz, resulting in angular resolution of approximately 2 degrees. And by increasing the sampling frequency the angular resolution can easily be improved. Moreover, the 1-bit signal processing has the capability of wide band process, allowing it to implement modulation and driving processes in the digital stage.

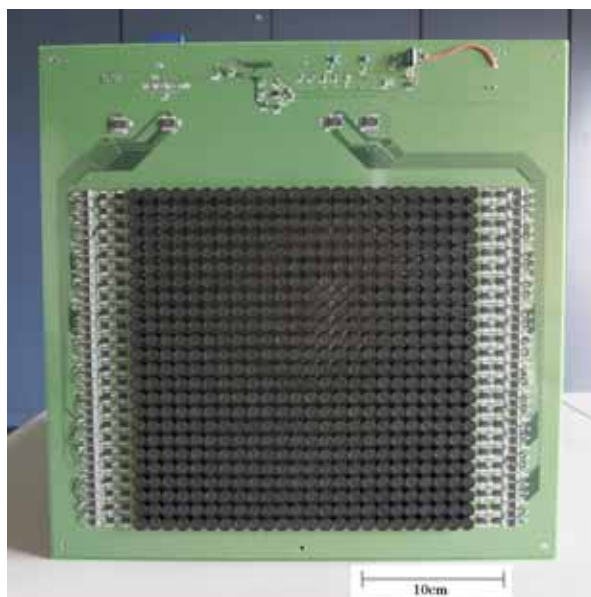

Figure 3. View of the parametric loudspeaker array. The dimension of the speaker part is approximately 244×244mm. 192 general-purposed IC 74AC04 is used as digital amplifier (10vpp) driven by 1-bit signal. The FPGA is EP2C8T144 by Altera Co.

EXPERIMENT

The setup

We prototyped a parametric speaker with 576(24×24) independently driven channels. The visual is shown on Fig. 3. The directivity of a single transducer used in this equipment is shown in Fig 4[5]. In this system, the output signal is called up from the SDHC memory card. The signal is pre-processed, and all of the delay control is done by 1 chip of Field Programmable Gate Array (FPGA).

By using this equipment, we did measurements about the directivity of controlled sound beam, visualization of the wavefront, and emitting multiple independent beams.

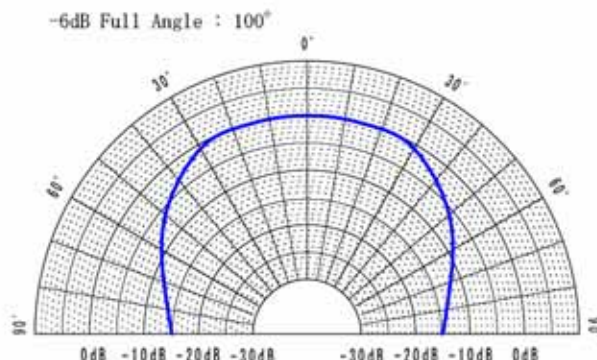

Figure 4. Directivity of a single ultrasonic transducer element. (T4010A: Nippon Ceramic Co.Ltd)

Beam direction control

For characterization of the output beam, a 4kHz sine wave is amplitude-modulated and directivity controlled from 0-60 degrees, 15degrees interval. The de-modulated audible signal is measured at 1m distance and 7.5 degrees interval. The results are shown in Fig 5. Though there is a difference of the level of the beams according to the angle, this is due to the directivity of the transducer element itself(Fig. 4). The observed sidelobes are discussed in the section of "POSITION OF TRANSDUCERS".

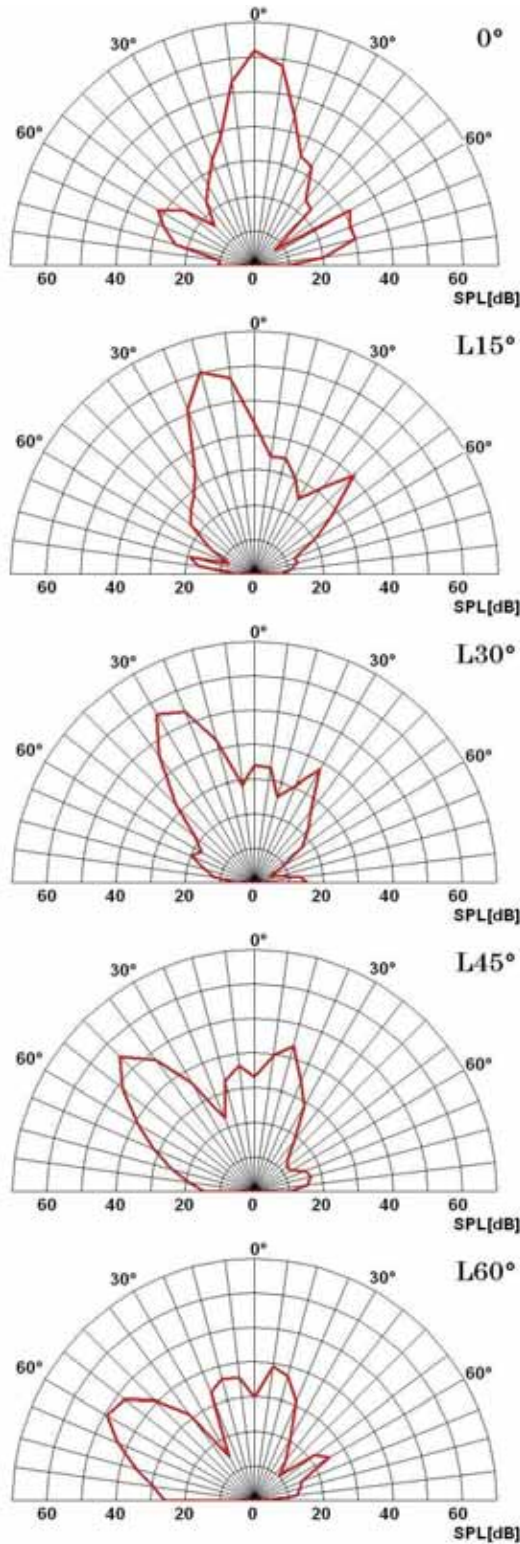

Figure 5. Directivity of the de-modulated 4kHz sine wave controlled at 15 degrees interval.

Measurement with laser scanning vibrometer

We have been researching the measurement of the sound velocity distribution by reflecting the laser from the laser-doppler vibrometer to a rigid wall and reading the changes in refractive index of air [6]. For this case, we used the laser scanning vibrometer (Polytec : PSV-300) and made visualization of the sound field possible. The result of acoustic imaging by the scanning laser-doppler vibrometer from 0 degree and 30 degrees directivity controlled signal is shown on Fig.6.

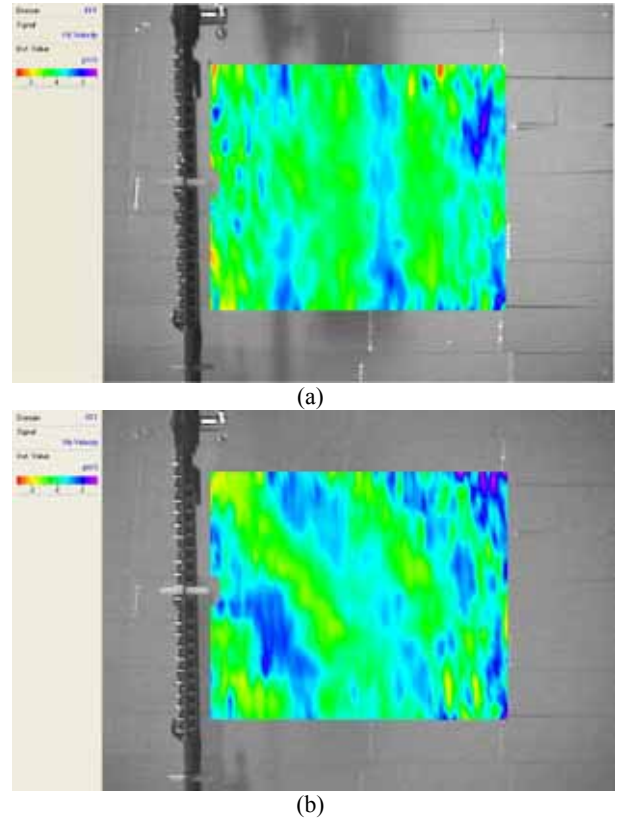

Figure 6. View of the directivity controlled 4kHz sine wave visualized by the method using scanning vibrometer. The measured beam is controlled to 0 degrees in figure (a), controlled to 30 degrees in figure (b). The sound velocity is shown from yellow (-2μm/s) to blue (2μm/s).

Multiple independent beams

By adding the signals of multiple direction-controlled beams, the concurrent output of different beams is made possible. As shown in Fig. 7, we performed an experiment of concurrent multi-direction output using 3 different sound beams. Fig. 7 shows the appearance of each original signal, and the de-modulated signals at 2m distance.

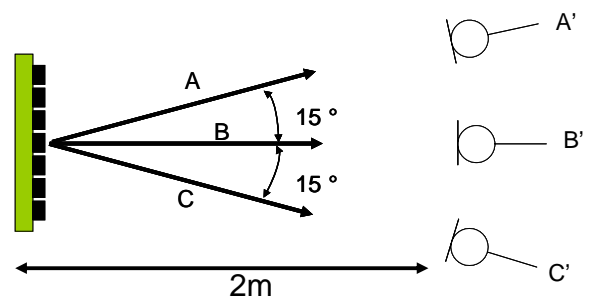
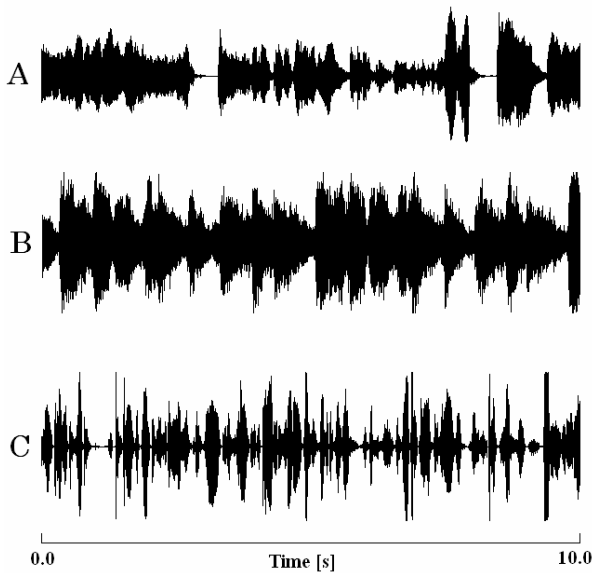
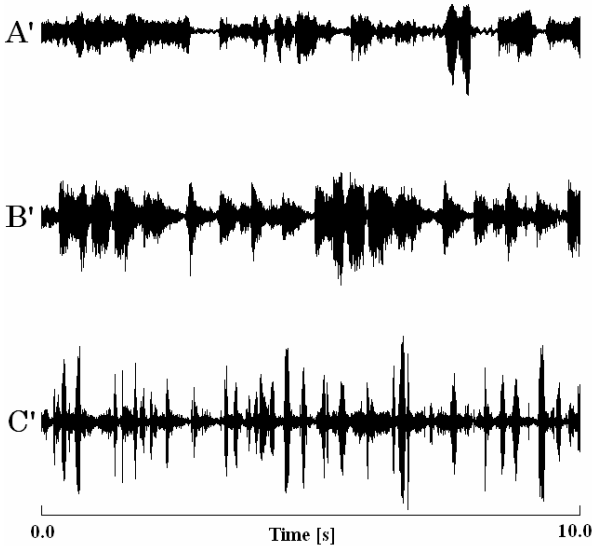

Figure 7. Measurement of 3 beams emitted concurrently. The beams A,B and C are directed at 0,15 and -15degrees.



(a) Waveform of sound sources



(b) Waveform of recorded sounds at each angle

Figure 8. The waveform of the sound sources and the recorded sounds. (A: Violin music, B: Pop music, C: Narration)

POSITION OF THE TRANSDUCERS

As seen in Fig. 5, sidelobes appear at approximately ± 60 degrees from the beam direction. This is coming from the fact that the position of transducers in the array is not fulfilling the sampling theorem of space. The direction of the emitted beams θ_N that produced from a speaker array which is set with the distance d interval is expressed by the following equation. θ_N includes the angle of desired beam and sidelobes.

$$\theta_N = \arcsin\left(\frac{cD + N\lambda}{d}\right) \quad (N = 0, \pm 1, \pm 2, \dots) \quad (2)$$

D is the delay time between the transducers for the directivity control, c is the speed of sound, θ_0 is the aiming direction, and λ is the wavelength. Thus, at the range of $-90^\circ \sim +90^\circ$ directivity control, it is possible to terminate the sidelobes ($N = 0$) by making $d < 1/2$.

The de-modulated sounds from the sidelobes have peaks and dips in directivity. This is because of the unmatched phases of the modulated signals though they are corresponding in the carrier phases.

In this equipment, the angle of the sidelobe beam θ_l is calculated with 56.8 degrees when the main beam is directed to the center from the interval of the transducers (10.16mm). And it is corresponding to the result in Fig 5. A position of the transducers and their simulated directivity of the demodulated 1kHz sine wave from 40kHz AM wave is shown in Fig 9. Here, we can see that, even if the diameter of the transducer exceeds the wavelength, it is possible to effectively suppress the sidelobes by setting the transducers in an appropriate position.

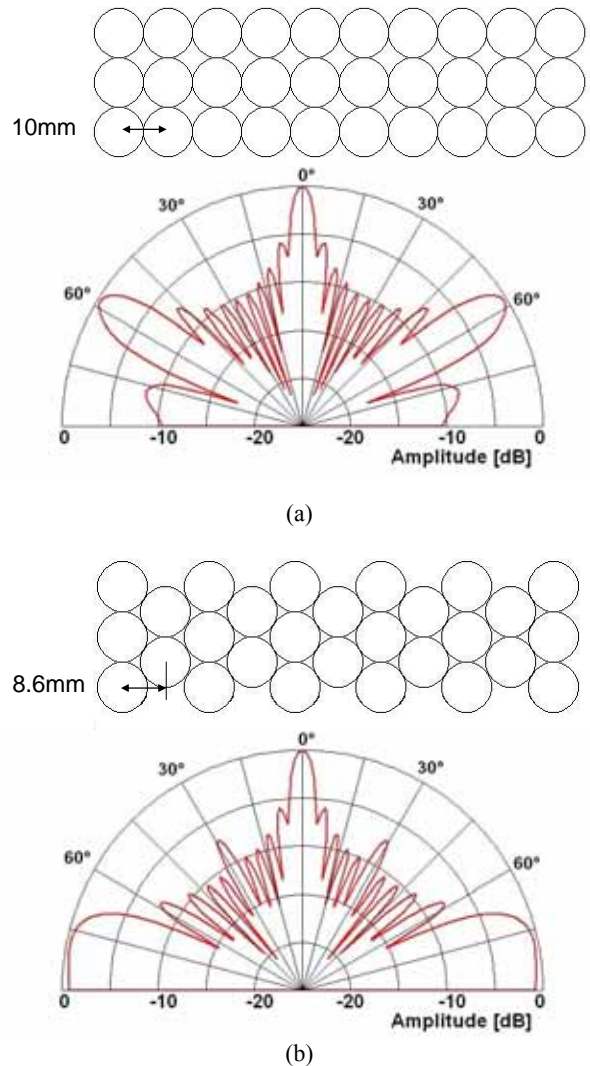

Figure 9. Position of the transducers and their simulated directivity of the demodulated 1kHz sine wave. In pattern (a), sidelobes are emitted at about 60 degrees. In pattern (b), the sidelobes are removed to outside of the actual range.

CONCLUSION

A parametric loudspeaker system able of controlling the angle of the emitted audio beam has been developed. By using 1-bit signal processing, individual control of 576 transducers was achieved very simply by low power consumption. Furthermore, the individual control of each transducer allows to generating multiple audio-beams, independent in both their directivity and sound source.

The problem of secondary beams (sidelobes) has been addressed and we could should in simulation that by changing the spacing between transducers.

Ultrasonic speaker can make the sound seem to come out from the wall that it reflects the ultrasonic sound. So we are going to try to implement a 3dimensional sound reproduction system using reflective walls as shown in Fig 10. Also, we are going to try to improve the de-modulation ratio from modulated ultrasounds by resonance of reflective walls.

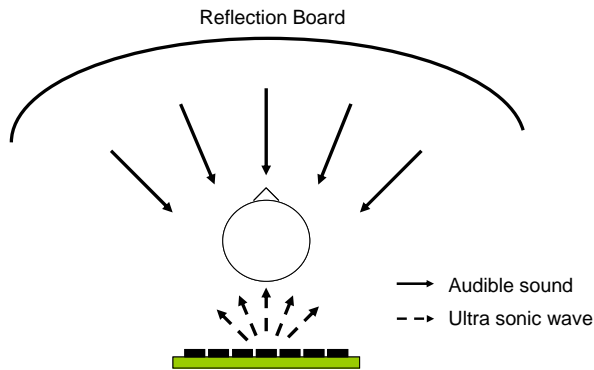

Figure 10. 3dimensional sound reproduction using directivity controllable parametric loudspeaker and reflection board

ACKNOWLEDGEMENT

This work was supported by Grant-in-Aid for Research Activity Start-up (21800062) supported by JSPS, Japan.

REFERENCES

- 1 P.J.Westervelt, "Parametric Acoustic Array" J. Acoust. Soc. Am **35**, 535-537 (1963)
- 2 M.Yoneyama, J.Fujimoto, "The audio spotlight: An application of nonlinear interaction of sound waves to a new type of loudspeaker design" J. Acoust. Soc. Am **73**, 1532-1536 (1983)
- 3 A.Nishio, G.Ichimura, Y.Inazawa, N.Honkawa, and T.Suzuki, "Direct Stream Digital Audio System" 100th Convention of AES, 4163 (1996)
- 4 R.Schreier, Gabor C. Temes, Understanding Delta-Sigma Data Converters (Wiley, New York 2004)
- 5 Nippon Ceramic Co.Ltd, "TECHNICAL DATA OF T4010A1" <http://www.nicera.co.jp>
- 6 Y.Oikawa, M.Goto, Y.Ikeda, T.Takizawa, Y.Yamasaki, "Sound Field Measurements Based on Reconstruction from Laser Projections" ICASSP, 661-664 (2005)