

Active Electromagnetic Suspension System for Improved Vehicle Dynamics

Bart L.J. Gysen, Johannes J.H. Paulides, Jeroen L.G. Janssen, and Elena A. Lomonova
Eindhoven University of Technology, The Netherlands. Email: B.L.J.Gysen@tue.nl

Abstract—This paper offers motivations for an active suspension system which provides for both additional stability and maneuverability by performing active roll and pitch control during cornering and braking as well as eliminating road irregularities, hence increasing both vehicle and passenger safety and drive comfort. Various technologies are compared to the proposed electromagnetic suspension system which uses a tubular permanent magnet (PM) actuator together with a passive spring. Based upon on-road measurements and results from the literature, several specifications for the design of an electromagnetic suspension system are derived. The measured on-road movement of the passive suspension system is reproduced by electromagnetic actuation on a quarter car setup proving the dynamic capabilities of an electromagnetic suspension system.

Keywords—Active Suspension; Permanent Magnet; Tubular Actuator

I. INTRODUCTION

Advanced electro-mechanical and electronic systems are increasingly installed to influence the dynamic performance of the vehicle, for example antilock braking systems (ABS), electronic brake force distribution (EBD), electronic stability program (ESP), etc. These systems are installed to improve vehicle handling and passenger safety, since this becomes an ever increasing demand for the automotive industry especially when cars tend to become smaller (SMART), incorporate a higher center of gravity (SUV) and reduced footprint. For instance, the transportation research board [1], reported that 51 % of the serious car accidents are caused by rollover.

Another trend in the automotive industry is the ‘more electric car’, for example the Toyota Prius. These hybrid vehicles combine the efficiency of an electric motor together with an internal combustion engine. Due to the global increase in oil prices and the importance of environmental sustainability, the ‘full electric car’ is also gaining attention. Recently, a Dutch energy company, Essent [2], launched a commercial electric car together with Electric Car Europe. These cars have a totally different weight distribution since the combustion engine is replaced by an electric motor together with a battery pack of around 400 kg. As such, the optimal electrical drivetrain efficiency is reached when completely incorporated in the wheel [3, 4]. However, as a result, the unsprung mass of the vehicle increases which is a disadvantage regarding passenger comfort and handling.

These trends clearly show the need of active suspension to be incorporated into vehicles. These systems allow for

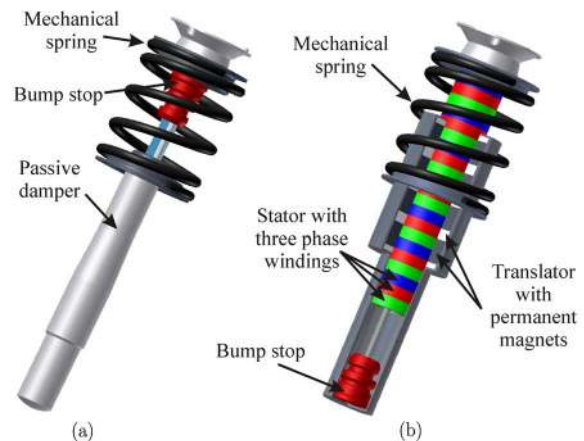

Figure 1. (a) Conventional passive suspension system, (b) electromagnetic suspension system

greater suspension articulation when driving under low-yaw circumstances (driving relatively straight) to absorb road irregularities and have a much more rigid response when the car is driven through turns which improves vehicle dynamics.

In order to facilitate the ideal suspension with regard to comfort, handling and safety, various commercial technologies are used to improve or replace the conventional passive suspension system shown in Fig. 1(a). This paper discusses an active electromagnetic suspension system incorporating a brushless tubular permanent magnet actuator in parallel with a mechanical spring [5], as illustrated in Fig. 1(b). This topology has been chosen since the tubular structure exhibits a high efficiency and excellent servo characteristics. Furthermore, the mechanical spring supports the sprung mass; hence no continuous power is needed. The main advantage of this system is that it simultaneously allows for both the elimination of the road disturbances and active roll and pitch control.

In section II, the ideal suspension regarding passenger comfort is discussed. Section III gives an overview of different technologies for active suspension which are compared to the proposed electromagnetic suspension system. Based upon the quarter car model, the influence of changing the sprung and unsprung mass is shown in Section IV. Various on-road and off-road measurements are performed on the current passive suspension system and specifications regarding force, power and stroke are derived for the active suspension system in Section V. Electromagnetic actuation is performed on a quarter car test setup which mimics the on-road measurements and conclusions are drawn in Section VI.

II. THE IDEAL SUSPENSION

The ideal automotive suspension would, independently, absorb road shocks rapidly and would return to its normal position slowly while maintaining optimal tire to road contact. However, this is difficult to achieve passively, where a soft spring allows for too much movement and a hard spring causes passenger discomfort due to road irregularities. Passenger comfort (combined with handling and safety) is an ever increasing demand, where everybody expects ever improving comfort and handling from the automotive industry. Albeit that a dearth of publications exists regarding passenger comfort, it was assumed that general comfort is improved when two conditions are minimized:

- Motion sickness, ~ 1 Hz [6], and
- head toss, $\sim 2-8$ Hz [7].

A. Motion sickness

Motion sickness, especially when reading, is a common by-product of exposure to optical depictions of inertial motion [8]. This phenomenon, called visually induced motion sickness (VIMS), has been reported in a variety of virtual environments, such as fixed-base flight and automobile simulators [9, 10, 11]. Further Gahlinger [12] discussed that motion sickness occurs most commonly with acceleration in a direction perpendicular to the longitudinal axis of the body, which is why head movements away from the direction of motion are so provocative. He further mentioned that vertical oscillatory motion (appropriately called heave) at a frequency of 0.2 Hz is most likely to cause motion sickness, although that the incidence of motion sickness falls quite rapidly at higher frequencies. This results in the design criteria for active systems that frequencies (lower than 1 Hz) need to be eliminated. This is underlined by surveys documenting that motion sickness occurs in 58 % of the children [6].

B. Head toss

Head toss happens when a car makes a sudden roll motion, e.g. occurring when one tire drives through a deep hole. This is not due to optical depictions but since the receptor mechanisms of the three orthogonally oriented canals in each inner ear are activated by angular acceleration of the head [12]. This especially occurs when a suspension with coupled left and right wheels is used as is the case with passive anti-roll bars. At frequencies below 1-2 Hz the head moved with the body, but in the frequency range of 2-8 Hz the amplitude of head acceleration is augmented indicating that oscillation about a centre of rotation low in the body may induce large angular movements in this frequency range because of the linear component of acceleration delivered at the cervical vertebrae. At higher frequencies, the acceleration at the head was attenuated with an associated increase in phase lag, probably due to the absorption of input acceleration by the upper torso [13].

Hence, the ideal suspension system should minimize the frequency response of the sprung mass displacement to the road disturbances in the band between 0.2 Hz and 10 Hz while maintaining a stiff ride during cornering. However, one of the main problems of an active suspension system is the absence of a fixed reference position and hence, only relative displacements can be measured. Next to that, it is difficult to distinguish the



Figure 2. Illustration of the active roll control (ARC) system of BMW using a hydraulic rotary actuator [14]

situation of roll during cornering and the condition where the right wheel experiences a different bump than the left wheel. Therefore, different sensor inputs, e.g. position, speed, acceleration, force and roll angle are preferred where, based upon these measurements, the exact state of the vehicle can be estimated in order to control the active suspension system.

III. ACTIVE SUSPENSIONS

A. Hydraulic systems

Due to the high force density, ease of design, maturity of technology and commercial availability of the various parts, hydraulic systems are used in body control systems. As an example, BMW recently developed an anti roll control (BMW-ARC) system by placing a hydraulic rotary actuator in the center of the anti roll bar at the rear of the vehicle [14], as shown in Fig. 2. Another example is given by the active body control system of Mercedes [15], which uses high-pressure hydraulics to pre-stress the spring, hence generating anti-roll forces without coupling the left and right wheel (as in the case of an anti-roll bar). All commercial body control systems use hydraulics to provide the active suspension system to improve vehicle roll behavior and ride control, where the main advantages of the hydraulic system are:

- Very high force density,
- ease of control,
- ease of design,
- commercial availability of the various parts,
- reliability and
- commercial maturity.

The main disadvantages of the hydraulic system are:

- Considered inefficient due to the required continuously pressurized system,
- relatively high system time constant (pressure loss and flexible hoses),
- environmental pollution due to hose leaks and ruptures, where hydraulic fluids are toxic,
- mass and intractable space requirements of the total system including supply system albeit that it mainly contributes to the sprung mass.

Hydraulic systems already proved their potential in commercial systems regarding active roll control since the bandwidth requirement is very small (order of Hz's), however, concerning reduction of road vibrations, the hydraulic system is cannot be used.

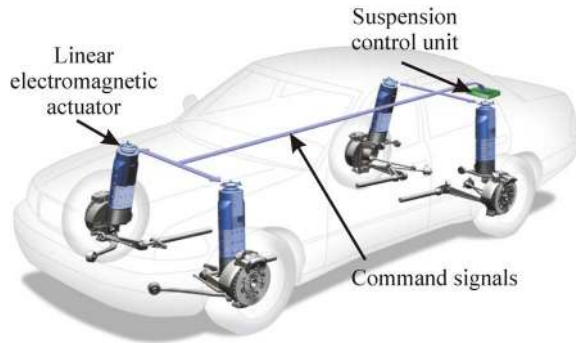

Figure 3. Illustration of the Bose® suspension [16]

B. Electromagnetic systems

An electromagnetic suspension system could encounter the disadvantages of a hydraulic system due to the relatively high bandwidth (tens of Hz), no need for continuous power, ease of control and absence of fluids. Linear motion can be achieved by an electric rotary motor with a ball-screw or other transducer to transform the rotary motion to linear translation. However, the mechanism required to make this conversion introduces significant complications to the system. These complications include backlash and increased mass of the moving part due to connecting transducers or gears that convert rotary motion to linear motion (enabling active suspension). More important that they also introduce an infinite inertia and therefore, a series suspension, e.g. where the electro-magnetic actuation is represented by a rotary motor connected to a ball-screw bearing, is preferable. These direct-drive electro-magnetic systems are more suited to a parallel suspension, where the inertia of the actuator is minimized.

Recently a system has been presented, namely the Bose® suspension system [16] shown in Fig. 3, which includes a linear electromagnetic motor and power amplifier at each wheel, and a set of control algorithms. In this system, the high bandwidth linear electromagnetic motor is installed at each wheel. This linear electromagnetic motor responds quickly enough to counter the effects of bumps and potholes, while maintaining a comfortable ride. Additionally, the motor has been designed for maximum strength in a small package, allowing it to put out enough force to prevent the car from rolling and pitching during aggressive driving maneuvers.

Electrical power is delivered to the motor by a power amplifier in response to signals from the control algorithms. The bi-directional power amplifier allows power to flow into the linear electromagnetic motor and also allows power to be returned from the motor. For example, when the suspension encounters a pothole, power is used to extend the motor and isolate the vehicle's occupants from the disturbance. On the far side of the pothole, the motor operates as a generator and returns the power back through the amplifier. It is attained that this suspension system requires less than a third of the power of a typical vehicle's air conditioning system, i.e. 100's Watts.

Compared to hydraulic actuators, the main advantages of electro-magnetic actuators are:

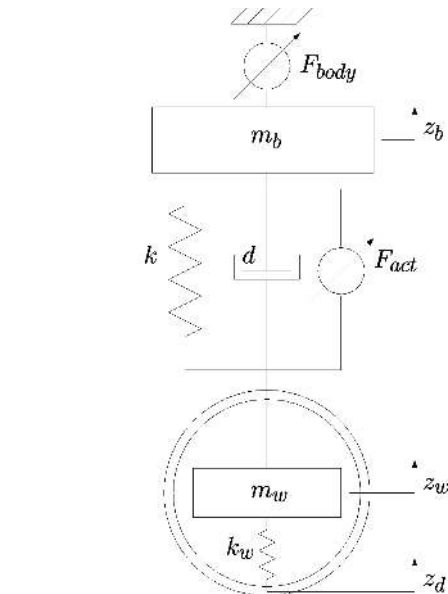

Figure 4. Quarter car model including body disturbances and active suspension

 TABLE I.
NOMINAL PARAMETERS OF THE QUARTER CAR MODEL

k	30 kN/m	Passive spring constant
kw	160 kN/m	Tire stiffness
d	1200 Ns/m	Passive damper constant
mb	450 kg	Quarter sprung mass
mw	40 kg	Unsprung mass

- Improved dynamic behavior,
- stability improvement,
- accurate force control and
- dual operation of the actuator.

The disadvantages are:

- Increased volume of the suspension, since the force density of the active part of hydraulics is higher than for electro-magnetic actuation, i.e. system mass and volume could be less,
- relatively high current for a 12-14V system and
- conventional designs need excitation to provide a continuous force.

Although numerous linear motor topologies exist, the PM synchronous linear actuator is investigated since it offers a high permissible power density at an ever decreasing cost penalty. More specifically a tubular PM synchronous actuator, as shown in Fig. 1(b), is preferred since this actuator inhibits the highest force density, where various different topologies are:

- Ironless (no attraction forces),
- ironless with back-iron (higher force density compared to a),
- slotted with soft magnetic powder composite materials (low saturation level) and
- laminated (difficult to achieve, however high force density).

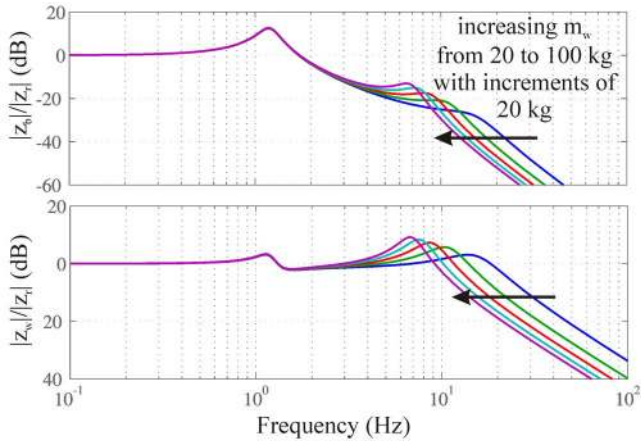

Figure 5. Bode diagrams of the sprung and unsprung mass response to road disturbances for increasing unsprung mass

The actuator topology achieving the highest force density is d), however b) is more preferred regarding manufacturing. Various magnetization patterns are possible, such as:

- Radially magnetized north and south poles,
- axially magnetized north and south poles with iron poles (no back-iron) and
- Halbach array (no back-iron).

In [17] a slotless tubular actuator is optimized for mean output force for all these magnetization patterns and for interior (moving magnet) and exterior (moving coil) magnet topologies. It has been shown that the exterior Halbach magnetization offers the highest output force within the volume constraints given by the BMW 545i.

IV. SYSTEM MODELING

In general, a full car model [18] is preferred to model the dynamic behavior of the suspension system, however roll and pitch behavior can also be modeled as an equivalent force disturbance acting on the body mass, F_{body} , and hence for the scope of this paper a quarter car model, as shown in Fig. 4, is used.

This model allows, for example, the investigation of increasing or decreasing the respective sprung and unsprung masses on the response of the body height z_b and wheel height z_w to road disturbances z_r (Figs. 5 and 6). From these Bode diagrams it can be observed that increasing the unsprung mass (for a wheel motor design [3, 4]) and decreasing the sprung mass (the more electrical car), or increasing the unsprung to sprung mass ratio, leads to an increase in response of the frequency range between 2 and 10 Hz which decreases the isolation of road disturbances and comfort as explained in Section II. Hence, the suspension system should be designed for maximum sprung to unsprung mass ratio while minimizing total mass.

V. SYSTEM SPECIFICATIONS

A. Roll and pitch behavior

During high speed cornering, braking and accelerating, roll and pitch forces tend to roll the body around a roll and pitch axes. As a result, the total weight is not evenly distributed along the four wheels which

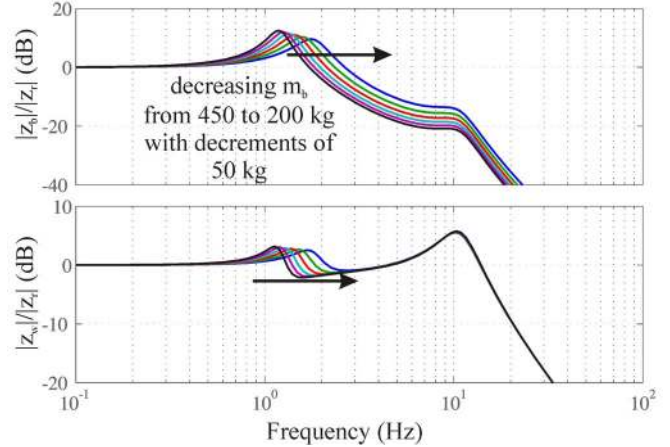

Figure 6. Bode diagrams of the sprung and unsprung mass response to road disturbances for decreasing sprung mass

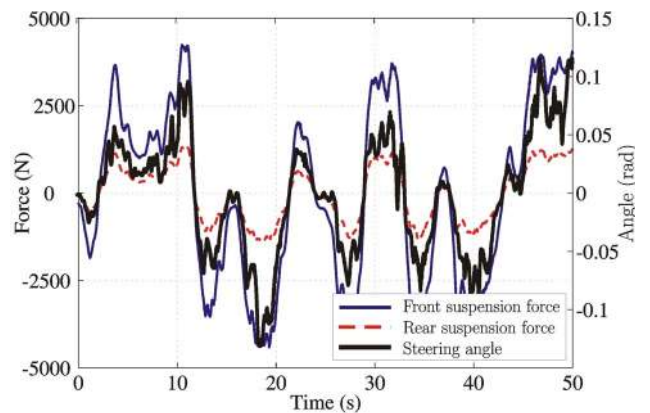

Figure 7. Time interval of the derived suspension forces from acceleration measurements on the Nürburgring together with the steering angle

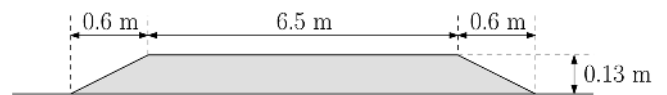

Figure 8. Sizes of the bump on the test track

increases the instability and could lead to tip over of the vehicle during cornering [19].

In order to have an indication of the particular roll forces during high speed cornering, a test drive with a BMW 545i is performed on the Nürburgring in Germany. The acceleration of the sprung mass is measured, and the resulting roll forces are calculated. A time interval of the calculated forces deducted from the measurements together with the steering angle is shown in Fig. 7. During calculation, a force ratio between front and rear suspension is assumed in order to design for safer under steer behavior. It can be observed that a peak force of 4 kN is necessary for the front actuators. To determine the mean force, the duty cycle has to be taken into account since the Nürburgring does not represent normal driving and road conditions. For example, assuming a duty cycle of 30 %, a mean force of around 700 N is necessary for the front actuators.

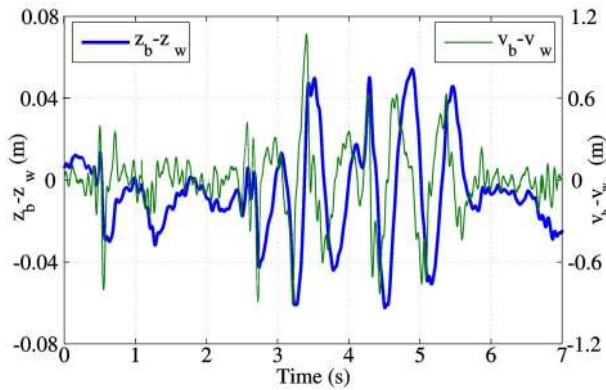

Figure 9. Position and speed measurements while driving on the bump of Fig. 8

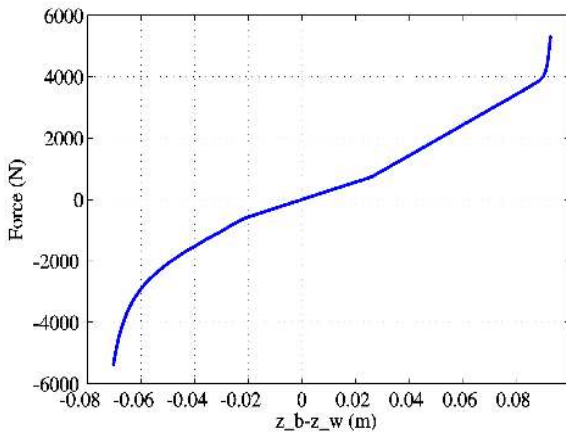

Figure 10. Measured spring characteristic of the passive suspension

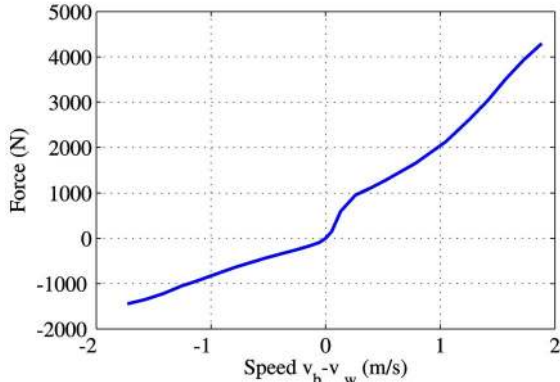

Figure 11. Measured damper characteristic of the passive suspension

B. Road disturbances

A further test drive is performed on a more common road with bumps and potholes. During this measurement, the relative vertical position between the sprung and unsprung mass is measured with an optical sensor. This sensor is aligned with the passive spring and damper, hence the stroke is directly measured. The speed is then derived, where a small time interval is shown in Fig. 9, where at that moment (2.5 s) the bump, shown in Fig. 8, is hit at 35 km/h. From these measurements the stroke, speed and force requirements of the suspension system can be derived. However, first the characteristics of the passive spring including the bump stop and damper need to be measured, e.g. using a standard VDA (Verband Der Automobilindustrie) test. This measurement is supplemented with additional points, as the maximum velocity in the VDA test is limited to 1.05 m/s.

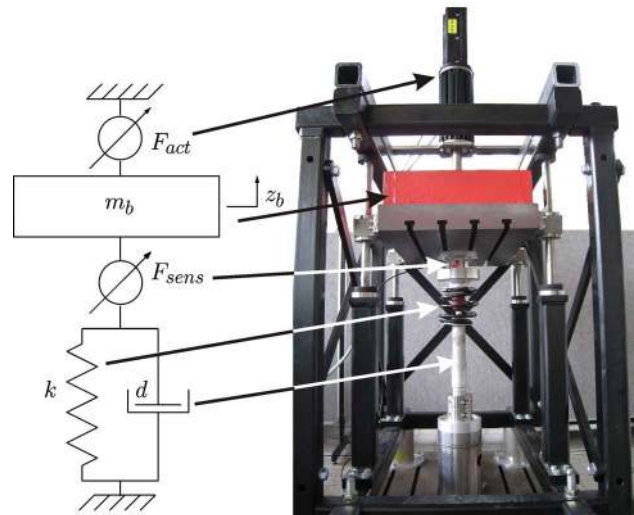

Figure 12. Quarter car test setup

 TABLE II.
STROKE AND SPEED MEASUREMENT RESULTS

	Max Bound	Max Rebound	Mean Bound	Mean Rebound
Stroke	80 mm	58 mm	4.5 mm	3.4 mm
Speed	1.28 m/s	2.25 m/s	38.5 mm/s	38.4 mm/s

Although that limit is sufficient for normal road behavior, when very steep bumps are hit, as shown in Fig. 9, the velocity increases beyond this point. The measured spring and damper characteristics are shown in Figs. 7 and 8, respectively. Using the on-road speed measurement together with the off-road measured damping characteristic, the absorbed power by the damper can be calculated. An instantaneous peak damping power of 2 kW is necessary when driving onto the bump shown in Fig. 8, however when taking the averaged value of the total driving cycle, only a power level of 16 W per damper is necessary, which is comparable with the results obtained in [20] for normal city driving.

VI. QUARTER CAR SETUP

In this section, the on-road measurements will be reproduced by means of electromagnetic actuation on a quarter car test setup shown in Fig. 11. The setup consists of a single moving mass, hence wheel dynamics are neglected, together with the passive suspension of a BMW 545i and a three phase brushless tubular permanent magnet actuator. The position and speed of the body mass of 450 kg, m_b , is measured with an incremental encoder attached to the actuator. The actuator is position and speed controlled with a reference position equal to the on-road measurement shown in Fig. 10. A feed forward controller which uses the measured spring and damper characteristic of Fig. 7 and 8, respectively, is used. Furthermore, a PID feedback controller ensures correct tracking of the reference and compensates the friction and cogging forces of the actuator and the setup. Hence, the actuator should apply the same forces as the passive suspension during

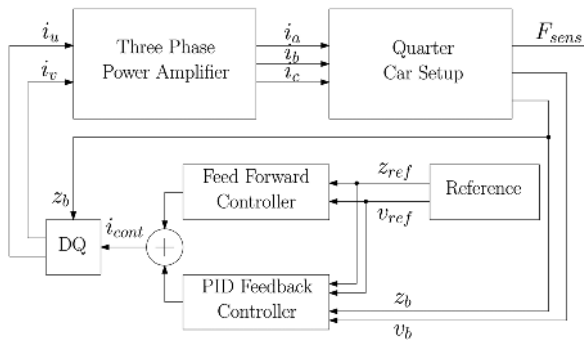

Figure 13. Block diagram of the measurement setup

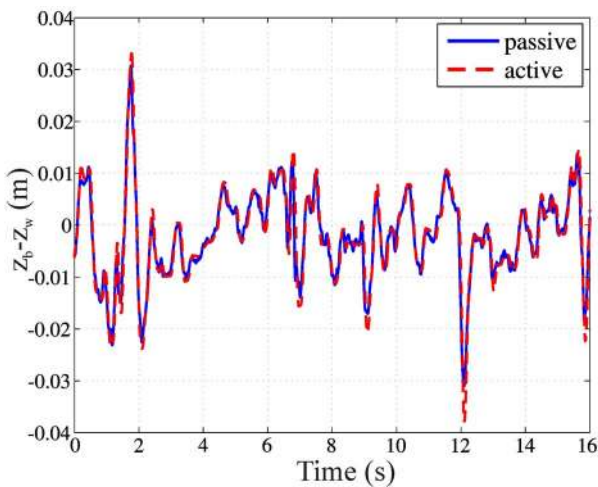

Figure 14. Time interval of the on-road measurements (passive) and off-road electromagnetic actuation on the quarter car test setup (active)

the test drive. The tracking of the actuator, shown in Fig. 14, gives an indication of the dynamic possibilities of electromagnetic actuation. The electromagnetic actuator has the possibility of applying forces equivalent to the passive suspension system within a very small response time (> 20 Hz). Hence, this force can be added to or subtracted from the passive suspension forces in order to obtain a variable suspension system for eliminating road vibrations.

VII. CONCLUSIONS

Due to the change in vehicle concepts to the more electric car, the suspension system becomes ever more important due to changes in the sprung and unsprung masses. Active electromagnetic suspension systems can maintain the required stability and comfort due to the ability of adaptation in correspondence with the state of the vehicle. Specifications are drawn from on-road and off-road measurements on a passive suspension system, and it can be concluded that for active roll control a peak force of 4 kN and an RMS force of 700 N are necessary for the front actuators. Furthermore, the necessary peak damping power is around 2 kW, however the RMS damping power is only 16 W during normal city driving. The maximum bound and rebound stroke are 80 and 58 mm, respectively. The on-road measurements are mimicked on a quarter car setup by means of

electromagnetic actuation, and a very good tracking response proves the dynamic performance of the electromagnetic suspension system.

ACKNOWLEDGMENT

The authors gratefully thank SKF for supporting this project.

REFERENCES

- [1] D.N. Wormley, K.M. Bauer, and J.E. Bernard, "The national highway traffic safety administrations rating system for rollover resistance," Transportation research board, Tech. Rep., 2002.
- [2] <http://www.essent.eu>, "Essent accelerates widescale use of electric cars", 2008.
- [3] K. Cakir and A. Sabanovic, "In-wheel motor design for electric vehicles," 9th IEEE International Workshop on Advanced Motion Control, pp. 613-618, 2006.
- [4] S. Zetterström, "Electromechanical steering, suspension, drive and brake modules," Proceedings of the IEEE Vehicular Technology Conference, vol. 3, pp. 1856-1863, 2002.
- [5] J.J.H. Paulides, L. Encica, E.A. Lomonova and A.J.A. Vandenput, "Design considerations of a semi-active electromagnetic suspension system," IEEE Transactions on Magnetics, vol. 39, no. 6, pp.1681-1688, 2003.
- [6] A.J. Benson, "Motion sickness," Stellman JM, et al, eds. Encyclopaedia of occupational health and safety. 4th ed. Geneva: International Labour Office, 1998:50.12-4.
- [7] G.R. Barnes and B.H. Rance, "Head movement induced by angular oscillation of the body in the pitch and roll axes," Aviat ion, Space and Environmental Medicine, vol. 46, pp. 987-93, 1975.
- [8] L.J. Smart, T.A. Stoffregen and B.G. Bardy, "Visually induced motion sickness predicted by postural instability," Human Factors, 44(3), 451-465, 2002.
- [9] L.H. Frank, J.G. Casali and W.W. Wierwille, "Effects of visual display and motion system delays on operator performance and uneasiness in a driving simulator," Human Factors, 30, 201-217, 1988.
- [10] E.C. Regan and K.R. Price, "The frequency of occurrence and severity of side-effects of immersion virtual reality," Aviation, Space and Environmental Medicine, vol. 65, 527-530, 1994.
- [11] Y. Yoo, G.C.H. Lee and S.A. Jones, "Vection, compensatory sway, and simulator sickness," In B. Dos & W. Karowski (Eds.), Advances in occupational ergonomics and safety, pp. 589-592, 1997.
- [12] P.M. Gahlinger, "Motion sickness - How to help your patients avoid travel travail," Postgraduate medicine online, Vol. 106, No. 4, 1999.
- [13] J.R. Lackner, "Motion sickness," In: Encyclopedia of Neuroscience, 3rd edition, CD-ROM version, G. Adelman, B. Smith (eds). Amsterdam: Elsevier Science, 2003.
- [14] M. Strassberger and J. Guldner, "BMW's Dynamic Drive: An active stabilizer bar system," IEEE Control Systems Magazine, vol. 24, no. 4, pp. 28-29, 2004.
- [15] Sachs ABC Module. [online]. Available: <http://www.zfsachs.com>.
- [16] W.D. Jones, "Easy ride: Bose Corp. uses speaker technology to give cars adaptive suspension," IEEE Spectrum, vol. 42, no. 5, pp 12-14, 2005.
- [17] B.L.J. Gysen, J.L.G. Janssen, J.J.H. Paulides and E.A. Lomonova, "Design aspects for an active electromagnetic suspension system for automotive applications," 43rd IEEE IAS annual meeting, Oktober 2008.
- [18] A. Kruczek and A. Stribrsky, "A full-car model for active suspension - Some practical aspects," Proceedings of the IEEE International Conference in Mechatronics, pp. 41-45, June 2004.
- [19] R. Cross, "Role of centrifugal force in vehicle roll," American Journal of Physics, vol. 67, no. 5, pp. 447-448, 1998.
- [20] P. Hsu, "Power recovery property of electrical active suspension systems," Proceedings of the Energy Conversion Engineering Conference, vol. 3, pp. 1899-1904, 1996.