

Active Multiport Subarrays for 5G Communications

Aslan, Yanki; Puskely, Jan; Roederer, Antoine; Yarovoy, Alexander

DOI

[10.1109/APWC.2019.8870449](https://doi.org/10.1109/APWC.2019.8870449)

Publication date

2019

Document Version

Final published version

Published in

IEEE-APS Topical Conference on Antennas and Propagation in Wireless Communications

Citation (APA)

Aslan, Y., Puskely, J., Roederer, A., & Yarovoy, A. (2019). Active Multiport Subarrays for 5G Communications. In *IEEE-APS Topical Conference on Antennas and Propagation in Wireless Communications* <https://doi.org/10.1109/APWC.2019.8870449>

Important note

To cite this publication, please use the final published version (if applicable). Please check the document version above.

Copyright

Other than for strictly personal use, it is not permitted to download, forward or distribute the text or part of it, without the consent of the author(s) and/or copyright holder(s), unless the work is under an open content license such as Creative Commons.

Takedown policy

Please contact us and provide details if you believe this document breaches copyrights. We will remove access to the work immediately and investigate your claim.

Green Open Access added to TU Delft Institutional Repository

'You share, we take care!' – Taverne project

<https://www.openaccess.nl/en/you-share-we-take-care>

Otherwise as indicated in the copyright section: the publisher is the copyright holder of this work and the author uses the Dutch legislation to make this work public.

Active Multiport Subarrays for 5G Communications

Yanki Aslan*, Jan Puskely[†], Antoine Roederer[‡], Alexander Yarovoy[§]

MS3 Group, Department of Microelectronics, Faculty of EEMCS, Delft University of Technology
Mekelweg 4, 2628 CD Delft, The Netherlands

{*Y.Aslan, [†]J.Puskely-1, [‡]A.G.Roederer, [§]A.Yarovoy}@tudelft.nl

Abstract—A novel hybrid beamforming architecture based on a phased array of active multiport subarrays is proposed for multi-user 5G applications. The subarrays have multiple simultaneous fixed beams which are smartly combined at the user locations with relatively large gains towards the intended co-frequency users and sufficiently low inter-user interference levels. The presented architecture has a wider angular coverage than the existing subarray-based hybrid beamforming schemes and reduces the signal processing complexity significantly as compared to the fully digital beamforming.

Index Terms—Butler matrix, fifth generation (5G), hybrid beamforming, multi-beam antenna, multi-user communication, space division multiplexing.

I. INTRODUCTION

In order to meet the challenging capacity requirements of 5G technologies, it is crucial to reuse the same frequency and time resources by exploiting the beamforming (or spatial filtering) properties of the antenna arrays [1]. Using distributed single beam antennas (SBAs) is currently proposed for 5G (Massive) MIMO base stations by Nokia Bell Labs [2], Ericsson [3], IBM [4] and NXP [5], which results in a multiplicity of single beam antennas, generally active phased arrays with analog beam forming and digital MIMO processing. The more ambitious alternative is to generate all the agile beams simultaneously from a single multiple beam antenna (MBA). The IEEE definition of MBA is as follows [6]: “An antenna capable of creating a family of major lobes from a single nonmoving aperture through the use of a multiport feed, with one-to-one correspondence between input ports and member major lobes, the latter characterized by having unique main-beam pointing directions”. MBAs have been used since decades for space applications. For example, with the Boeing Spaceway system [7], the same 500 MHz band is reused 24 times in 24 simultaneous beams around 20 GHz.

The multiple beam antennas (MBAs) can roughly be grouped into two categories: (i) passive/active multiple fixed beam antennas (MFBAs), (ii) passive/active multiple beam phased array antennas (MBPAAs). The phrase ‘active’ means that the LNA and PA are placed just behind each antenna element or subarray, which helps compensate the losses in the beamforming network and generate larger RF power.

MFBAs are mainly based on reflectors [8], lenses [9] or beamforming circuits (transmission lines, directional couplers etc.) [10]. At the output, a fixed number of beams are created only in specific directions. Such a limitation is not compatible with the demanding 5G performance criteria that require flexible beamforming and versatility. The passive

and active MBPAAs, on the other hand, have the ability to scan the simultaneously created beams. As indicated in [11], active MBPAAs can achieve much better power efficiency and system linearity than the passive MBPAAs. Therefore, it can be inferred that active MBPAAs are the most suitable candidates for simultaneous multi-user 5G communication.

In MBAs, the beams can be generated in various ways depending on the beamforming strategy. The possible options are based on fully-analog, fully-digital and hybrid schemes. Among these options, fully-analog MBAs are not as flexible, versatile and robust-to-failure as fully-digital ones. They also suffer from combining losses that must be compensated by the amplifier gain. On the other hand, fully-digital MBAs suffer from high design cost and complexity. Therefore, being an attractive compromise between the performance and complexity, several hybrid beamforming strategies have recently been proposed in the 5G literature [12]. In the past few years, hybrid topologies received a lot of attention, especially in the signal processing community [13], [14], due to the need for highly-complex beamforming algorithms. It has been shown that baseband processing and RF beamforming can be efficiently combined using elementary antenna elements. However, for the antenna community, it is still a challenge to make use of smart antenna designs that help reduce the design complexity, computational burden and required resources.

In this paper, the existing beamforming architectures for the 5G base station antennas are reviewed with examples of the state-of-the-art prototypes both from the industry and academia. Considering its potential on decreasing the design complexity/increasing the angular coverage range as compared to the current hybrid schemes, and reducing the DSP complexity as compared to the fully-digital beamforming, a new hybrid beamforming architecture is proposed which is called as active multiport subarray phased array antenna (AMSPAA).

The rest of the paper is organized as follows. Section II shows the possible beamforming architectures that can be used in 5G base stations and introduces the newly-proposed active multiport subarray topologies. Section III presents the radiation pattern simulation results of the proposed architecture using a smart array layout design. The conclusions are given in Section IV.

II. MULTIPLE BEAM GENERATION STRATEGIES IN 5G

In this section, first, some of the existing active 5G beamforming architectures will be covered and the advantages/disadvantages of each will be explained taking into account the current status of the industry. Later, a novel active multiport subarray based array topology will be introduced

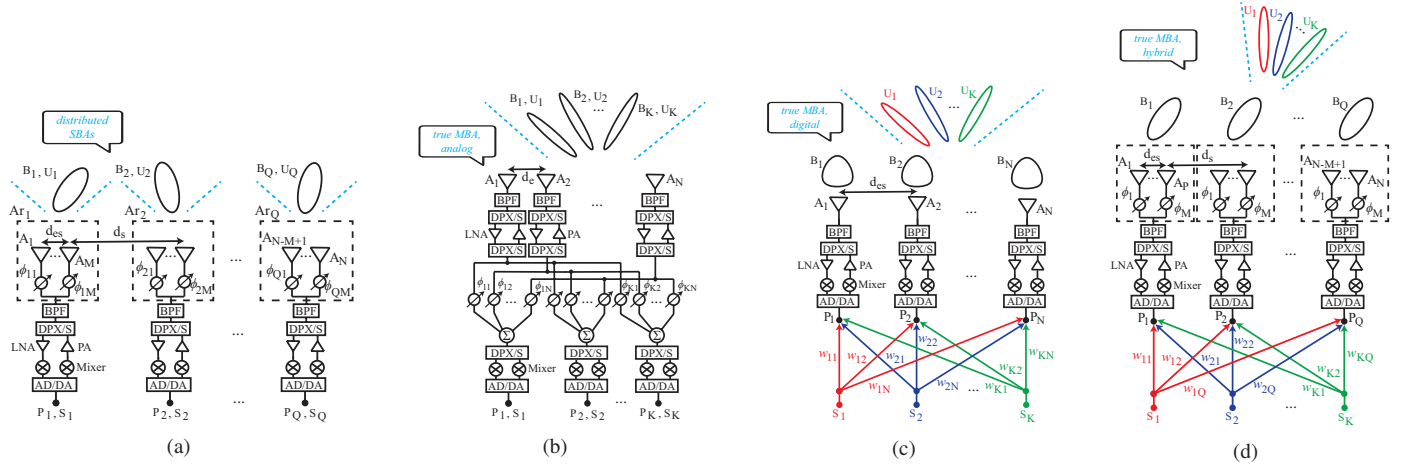

Fig. 1. Potential active multi-beam generation architectures proposed in the 5G literature: (a) classic analog MIMO array, (b) fully-connected array, (c) fully-digital array, (d) array of phased subarrays. (A: antenna element, Ar: antenna array, P: antenna port, S: user stream, B: antenna beam, U: user beam)

considering the trade-offs between the design complexity, radiation performance and digital signal processing (DSP) burden. Interested readers are referred to [15] for a deeper discussion on the possible antenna technologies for 5G.

In 5G, ideally, each stream needs one own beam. Otherwise, if several streams share the same beam, as was the case in the previous generations, the system will not be optimum. Currently, the industrial baseline 5G antennas are mostly based on the classical analog MIMO array (possibly with additional baseband processing) which is shown in Fig. 1(a). In this configuration each stream only uses a single array (with P elements) among many ($= Q$) closely located or distributed single beam arrays. Therefore, the full potential of the overall antenna array is not exploited, which results in relatively wide beams with low gain unless each array is large enough. Besides, the power sharing flexibility and efficiency between all beams and streams is not at all as good as with a true MBA where all the power can be put in a single stream, if needed.

Fig. 1(b) shows an alternative structure which will be called as the true multi-beam analog array. The massive advantages of this topology as compared to classical MIMO arrays with the same total number of elements are: (i) each stream benefits from the full gain (and if needed full power) of all the array elements and not only from the gain of one “sub-array”, in other words, the gain is multiplied by \sqrt{Q} , (ii) the power needed per stream is divided by Q for the same EIRP, (iii) since the beams are \sqrt{Q} times narrower, it is possible to re-use the same frequency Q times more thus, in theory, multiply the spectrum efficiency by Q . However, in true multi-beam arrays, there is a large number of phase shifters and adders (with combining losses) and each beam has its own beamforming network. Due to the system complexity, the literature is not rich regarding the implemented true multi-beam arrays. Some examples can be found in radio astronomy [16], satellite communications [17], [18], radar defense [19] areas.

Fig. 1(c) presents the fully digital architecture which is considered as the final goal since it is able to provide the most flexible, accurate and versatile performance via beamforming in the baseband. Each stream uses all the antenna elements and each element has a separate RF chain, but no phase shifters

or adders are used. The major issues with the fully digital architectures are the cost and complexity, which increase significantly with the number of simultaneous beams and the number of array elements. Earlier designs with fully-digital arrays were mainly used in military radar applications [20] and satellite communications [21]. Later, with the development of advanced DSP chips, the application domains have been extended to personnel imaging [22], automotive radar [23] and so on. Very recently, the first 5G fully-digital array hardware was presented in [24]. However, the industrial high-volume 5G market is still far from that due to many practical factors such as cost, design complexity, cooling and computational burden.

Considering the drawbacks of the fully-digital arrays, hybrid architectures have been proposed for 5G base stations. Due to having less number of RF chains, hybrid beamforming can lower the system cost and complexity, which comes at the expense of performance reduction. The most commonly used hybrid architecture, namely the array of phased subarrays is given here in Fig. 1(d). In this case, since the angular coverage range is limited by the subarray pattern, only a small sector (defined by the number of subarray elements, P) can be covered. The covered sector can be steered in the array consisting of phased subarrays. As previously mentioned, hybrid architectures are getting a lot of attention from the signal processing experts, but the implemented hybrid beamforming prototypes are still very limited [25], [26].

Very recently, hybrid beamforming schemes using a single passive multiple fixed beam antenna (Rotman lens [27] or Butler matrix [28]) have also been proposed to achieve more simplicity through exploiting multiple fixed analog beams covering a wide sector and controlling them digitally in the baseband. However, it is well-known that in 5G (especially at mm-waves), sharp beams with large gains are needed to satisfy the link budget and allow sufficient frequency reuse. This may lead to large ($N \times N$ where $N \geq 16$) multiple fixed beam antenna structures that can result in bulky designs with high design complexity, insertion loss, power inefficiency and parasitic radiation.

In this contribution, we propose the active multipoint subarray phased array antenna (AMSPAA) architecture shown

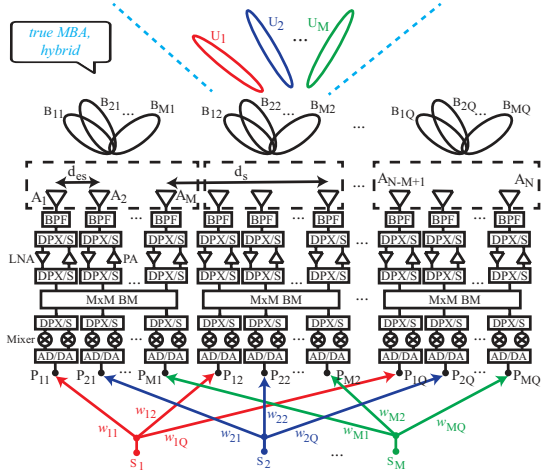

Fig. 2. Proposed AMSPAA architecture with fixed-beam multiport subarrays.

in Fig. 2 which combines several ($= Q$) multiport subarrays with P elements and backed by $P \times P$ Butler matrices (BMs) where P is relatively small so that the overall design is less lossy, more compact and power-efficient. The major advantage of the active multiport subarrays over the array of phased subarrays is the increased angular coverage via the use of multiple Butler beams. Besides, compared to their fully-digital counterparts, AMSPAAs greatly reduce the processing complexity since instead of all the antenna elements, the digital weights are applied only to the BM ports corresponding to the user positions.

The major advantages (A-i–A-v) / disadvantages (D-i–D-iv) of the AMSPAAs can be summarized as follows:

(A-i) AMSPAAs can be straightforwardly integrated with 1D arrays (such as array of 5G cosecant subarrays as in [29]) or efficient 2D beamforming can be achieved with planar antenna layouts (see Section III).

(A-ii) The DSP complexity is remarkably less as compared to the fully-digital beamforming. For example, if we assume conjugate-beamforming (CB) or zero-forcing (ZF) pre-coding at the baseband, the number of floating point operations (\mathcal{F}_{CB} , \mathcal{F}_{ZF}) is given by [30]

$$\mathcal{F}_{CB} = K(14N - 2)$$

$$\mathcal{F}_{ZF} = K(24(K - 1)N^2 + 48(K - 1)^2N + 54(K - 1)^3 + 6N)$$

where K is the number of simultaneous users and N is the number of antennas in fully-digital arrays which is replaced by Q , the number of subarrays, in AMSPAAs. If we assume an array with $N = 32$, $Q = 8$, $K = 4$, DSP complexity of the AMSPAA becomes 25% and 10% of the fully-digital beamforming in the case of CB and ZF precoding, respectively. For an array with $N = 128$, $Q = 16$, $K = 8$, the DSP complexity of the AMSPAA is reduced to only 12% and 3% of the fully-digital array for CB and ZF, respectively.

(A-iii) Optimally, P well-separated far-away users can be simultaneously served by making use of all the subarrays for each user (as shown in Fig. 2).

(A-iv) In principle, depending on the users' EIRP requirements, instead of serving P far-away users, $K > P$

closeby users can be served using different sets of subarrays for different users. Yet, it might be more preferable to have all the available gain in order to save power.

(A-v) In the case of having a few well-separated simultaneous co-frequency users, it is possible to send the same user stream to multiple BM ports as in [31] and reduce the side lobe level with no additional DSP algorithms such as ZF. However, this comes at the expense of the increased beamwidth and reduced gain that occurs because of the amplitude tapering in the subarrays.

(D-i) The hardware requirements of AMSPAAs become comparable to the fully-digital arrays if PAs are used at each antenna port to compensate the BM losses. However, in the case of having low loss matrices, the array could be powered at the subarray ports only, which reduces the number of amplifiers by a factor of M . In addition, there can be cases where all the matrices/sub-arrays input ports are not used at the same time (particularly in a 2D array) or if the number of simultaneous users is restricted. Then, it might be worth having less power greedy A/D and D/A converters than subarray ports by introducing an RF (or IF) ‘String to Sector Port’ switching matrix. This concept is visualized in Fig. 3 where two users switch between the beam ports associated with the upper and lower angular sectors.

(D-ii) The number of simultaneously served far-away users (that need the gain from all the subarrays) is limited by the number of BM ports. However, in [32], it was shown that the number of users cannot be very large ($K, P < 8$ for the current chip technologies) due to the thermal management problems which is preferred to be handled passively via natural convection [33].

(D-iii) Due to large spacing between the subarrays, grating lobes (GLs) will occur in the field of view which may create very large interference if not suppressed. Besides, ZF algorithm does not work for two users located near each other's grating lobes [33]. However, placing the subarrays smartly can help suppress the GLs and allow us to use CB or ZF [33] with sufficiently low interference. An alternative way to dissolve the GLs is to use overlapped subarrays [34] (with a more complex analog beamformer) instead of the contiguous ones, which is not discussed in this paper.

(D-iv) Two (or more) far-away users positioned in the same Butler beam have to be served at different times or frequencies due to the large scan loss in the adjacent Butler beams' patterns that have to be steered. Alternatively, each user

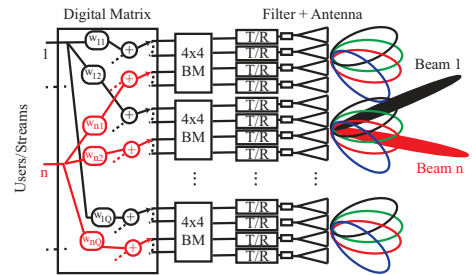

Fig. 3. A sample use of multiport sub-arrays of 4 elements fed by 4x4 Butler Matrix to reduce DSP and hardware requirements.

can simultaneously use different portions of all the subarrays with less gain, which might work for the closeby users.

III. SIMULATION RESULTS

In this section, we propose a planar array version of AMSPAA with 0.5λ -spaced triangular lattice at element level and grating lobe dissolving row shifting in a diamond like configuration. The elements are grouped in horizontal subarrays which are staircase shifted to reduce grating/side lobes over the ± 60 degree (in azimuth) by ± 15 degree (in elevation) field of view, which is currently defined as the typical 5G angular sector [3].

The array layout is given in Fig. 4. In total, 256 elements are used with 64 4×4 BMs. The cell sector is visualized in Fig. 5 in the u - v plane. The sector is divided into four regions. Each Butler beam is responsible for serving a separate region.

The progressive phase shifts in a 4×4 BM for excitation of each port is provided in Table I. By exciting the first port of each BM and applying the proper phase shifts, the beam is scanned in Region I. The same principle applies to the other BM ports (2, 3, 4) and the corresponding regions (II, III, IV).

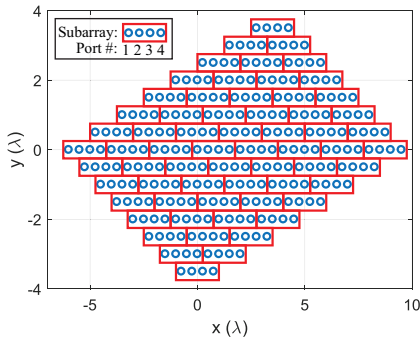

Fig. 4. The proposed AMSPAA layout.

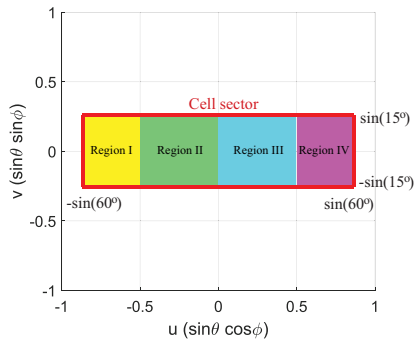

Fig. 5. Division of angular regions corresponding to the multiport subarray beams in a typical 5G cell sector.

TABLE I. PROGRESSIVE PHASE SHIFTS IN A 4-ELEMENT SUBARRAY FED BY A 4×4 BM

Excited subarray port #	Progressive phase shift in the subarray (in degrees)
1	+135
2	+45
3	-45
4	-135

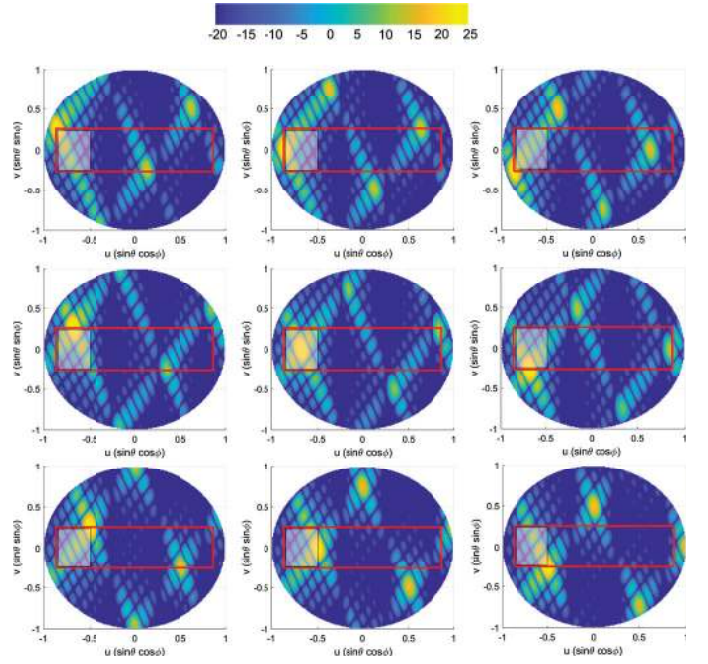

Fig. 6. Array directivity (in dBi) for a beam scanned inside Region I.

Next, the CB pre-coding radiation pattern results for two beams scanned in Region I and Region II are shown. It is worthy of note that due to the symmetry in the layout, the beams in Region III and Region IV will have the symmetrical pattern properties as compared to the results given for Region II and Region I, respectively.

Fig. 6 shows the array directivity when a beam is scanned in Region I by applying the proper progressive phase shift to the first ports of the 64 subarrays. An isolated element pattern

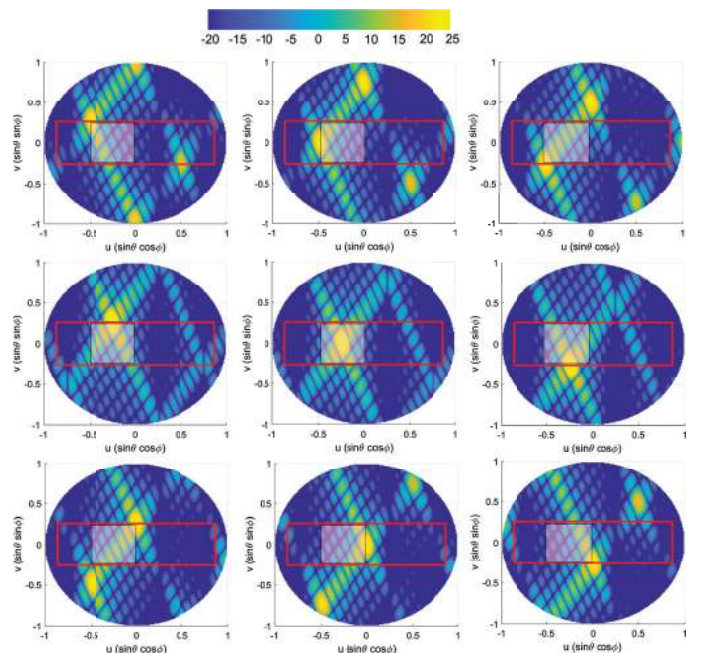

Fig. 7. Array directivity (in dBi) for a beam scanned inside Region II.

of $\sqrt{\cos\theta}$ is assumed with a directivity equal to 6 dBi. It is seen that in majority of the cases, the average interference within the sector is sufficiently low (side/grating lobes are all below -15 dB and most below -30 dB even for the worst scan condition). A high interference level (-8 to -10 dB) is only observed at specific areas in Region IV when $u = -\sin(60^\circ)$ and when $u = -\sin(30^\circ)$, $v = \sin(15^\circ)$.

Similarly, Fig. 7 shows the pattern results for a beam scanned in Region II for the excitation of the second BM ports. In this case, compared to Fig. 6, much cleaner beams are obtained. The only high interference is observed at the lower part of the boundary between Region III and Region IV when the beam is scanned towards the top left of Region II, where $u = -\sin(30^\circ)$, $v = \sin(15^\circ)$. This is expected since the pattern must be in line with the results given in Fig. 6 at the boundary shared between Region I and Region II.

Overall, competitive radiation pattern results to the fully-connected and fully-digital arrays with 0.5λ -spacing are observed using the proposed AMSPAA topology in the defined cell sector. In the case of having the channel state information or user positions available, it is also possible to further decrease the inter-user interference in AMSPAAs by applying ZF pre-coding, while maintaining relatively low side/grating lobes everywhere inside the sector. As previously mentioned in Section II-(D-i), further reduction in the processing and hardware (LNA/PAs, AD/DAs, mixers, DPXs) requirements can be achieved with the use of only one or two of four BM ports at a time with a switching network (see Fig. 3).

IV. CONCLUSION

An original 5G multi-user hybrid beamforming architecture has been presented. The proposed technique is based on relatively small-sized active subarrays with multiple ports generating multiple fixed beams that are digitally controlled in the baseband.

The state-of-the-art 5G active multi-beam phased array architectures have been reviewed and qualitatively compared with the proposed scheme. It has been shown that as compared to existing analog and hybrid multiple beamforming methods, active multiport subarrays can decrease the design and implementation complexity and/or increase the angular sector coverage. Besides, by introducing a smart 2D array layout of the subarrays, competitive radiation performance to the fully digital beamforming has been obtained while reducing the processing complexity significantly.

Hardware simplification in multiport subarrays can also be achieved by scheduling use of only one or two sub-array ports/beams at the same time with a switching arrangement.

ACKNOWLEDGMENT

This research was conducted as part of the NWO-NXP Partnership Program on Advanced 5G Solutions within the project titled "Antenna Topologies and Front-end Configurations for Multiple Beam Generation". More information: www.nwo.nl.

REFERENCES

- [1] H. Magri, N. Abghour, and M. Ouzzif, "Key concepts of 5th generation mobile technology," *WASET IJECE*, vol. 9, no. 4, pp. 471–474, 2015.
- [2] R. Valkonen, "Compact 28-GHz phased array antenna for 5G access," in *Proc. IEEE/MTT-S IMS*, Philadelphia, Pennsylvania, Jun. 2018.
- [3] E. Degirmenci, "Emf test report: Ericsson AIR 5121," Ericsson AB, Stockholm, Sweden, Tech. Rep. GFTB-17:001589 Uen Rev B, Jan. 2018.
- [4] B. Sadhu, Y. Touse, J. Hallin, S. Sahl, S. Reynolds, O. Renstrom, K. Sjogren, O. Haapalahti, N. Mazar, B. Bokinge, G. Weibull, H. Bengtsson, A. Carlinger, E. Westesson, J.-E. Thillberg, L. Rexberg, M. Yeck, X. Gu, D. Friedman, and A. Valdes-Garcia, "A 28 GHz 32-element phased-array transceiver IC with concurrent dual polarized beams and 1.4 degree beam-steering resolution for 5G communication," in *Proc. IEEE ISSCC*, San Francisco, CA, USA, Feb. 2017.
- [5] Y. Aslan, C. E. Kiper, A. J. van den Biggelaar, U. Johannsen, and A. Yarovoy, "Passive cooling of mm-wave active integrated 5G base station antennas using CPU heatsinks," in *Proc. 49th EuMC*, Paris, France, Oct. 2019, accepted for publication.
- [6] *IEEE Standard for Definitions of Terms for Antennas*. IEEE Standard 145-2013, Dec. 2013.
- [7] D. Whitefield, R. Gopal, and S. Arnold, "Spaceway now and in the future: on-board IP packet switching satellite communication network," in *Proc. IEEE MILCOM*, Washington, DC, USA, Oct. 2006.
- [8] S. Rao, L. Shafai, and S. Sharma, *Handbook of reflector antennas and feed systems*. Norwood, MA, USA: Artech House, 2013.
- [9] O. Quevedo-Teruel, M. Ebrahimpouri, and F. Ghasemifard, "Lens antennas for 5G communications systems," *IEEE Commun. Mag.*, vol. 56, no. 7, pp. 36–41, Jul. 2018.
- [10] J. Butler and R. Lowe, "Beamforming matrix simplifies design of electronically scanned antennas," *Electron. Des.*, vol. 9, pp. 170–173, Apr. 1961.
- [11] A. Jacob-Hood and E. Lier, "Multibeam active phased arrays for communications satellites," *IEEE Microw. Mag.*, vol. 1, no. 4, pp. 40–47, Dec. 2000.
- [12] I. Ahmed, H. Khammari, A. Shahid, A. Musa, K. S. Kim, E. D. Poorter, and I. Moerman, "A survey on hybrid beamforming techniques in 5G: Architecture and system model perspectives," *IEEE Commun. Surv. Tut.*, vol. 10, no. 3, pp. 501–513, Apr. 2016.
- [13] F. Sohrabi and W. Yu, "Hybrid digital and analog beamforming design for large-scale antenna arrays," *IEEE J. Sel. Topics Signal Process.*, vol. 10, no. 3, pp. 501–513, Apr. 2016.
- [14] T. Kim, J. Park, J.-Y. Seol, S. Jeong, J. Cho, and W. Roh, "Tens of gbps support with mmwave beamforming systems for next generation communications," in *Proc. IEEE GLOBECOM 2013*, Atlanta, GA, USA, Dec. 2013.
- [15] W. Hong, Z. H. Jiang, C. Yu, J. Zhou, P. Chen, Z. Yu, H. Zhang, B. Yang, X. Pang, M. Jiang, Y. Cheng, M. K. T. Al-Nuaimi, Y. Zhang, J. Chen, and S. He, "Multibeam antenna technologies for 5G wireless communications," *IEEE Trans. Antennas Propag.*, vol. 65, no. 12, pp. 6231–6249, Dec. 2017.
- [16] G. W. Kant, P. D. Patel, S. J. Wijnholds, M. Ruiter, and E. van der Wal, "EMBRACE: A multi-beam 20,000-element radio astronomical phased array antenna demonstrator," *IEEE Trans. Antennas Propag.*, vol. 59, no. 6, pp. 1990–2003, Jun. 2011.
- [17] P. L. Metzen, "Globalstar satellite phased array antennas," in *Proc. IEEE Int. Conf. Phased Array Syst. Technol.*, Dana Point, CA, USA, May 2000.
- [18] D.-W. Kang, K.-J. Koh, and G. M. Rebeiz, "A Ku-band two-antenna four-simultaneous beams SiGe BiCMOS phased array receiver," *IEEE Trans. Microw. Theory Techn.*, vol. 58, no. 4, pp. 771–780, Apr. 2010.
- [19] K. J. Maalouf and E. Lier, "Theoretical and experimental study of interference in multibeam active phased array transmit antenna for satellite communications," *IEEE Trans. Antennas Propag.*, vol. 52, no. 2, pp. 587–592, Feb. 2004.
- [20] H. Steyskal and J. F. Rose, "Digital beamforming for radar systems," *Microw. J.*, vol. 32, no. 1, pp. 121–136, Jan. 1989.
- [21] R. Miura, T. Tanaka, I. Chiba, A. Horie, and Y. Karasawa, "Beamforming experiment with a dbf multibeam antenna in a mobile satellite

- environment,” *IEEE Trans. Antennas Propag.*, vol. 45, no. 4, pp. 707–714, Apr. 1997.
- [22] S. S. Ahmed, A. Genghammer, A. Schiessl, and L.-P. Schmidt, “Fully electronic E-band personnel imager of 2 m² aperture based on a multistatic architecture,” *IEEE Trans. Microw. Theory Techn.*, vol. 61, no. 1, pp. 651–657, Jan. 2013.
- [23] W. Menzel and A. Moebius, “Antenna concepts for millimeter-wave automotive radar sensors,” *Proc. IEEE*, vol. 100, no. 7, pp. 2372–2379, Jul. 2012.
- [24] B. Yang, Z. Yu, J. Lan, R. Zhang, J. Zhou, and W. Hong, “Digital beamforming-based massive MIMO transceiver for 5G millimeter-wave communications,” *IEEE Trans. Microw. Theory Techn.*, vol. 66, no. 7, pp. 3403–3418, Jul. 2018.
- [25] W. Roh, J.-Y. Seol, J. Park, B. Lee, J. Lee, Y. Kim, J. Cho, K. Cheun, and F. Aryanfar, “Millimeter-wave beamforming as an enabling technology for 5G cellular communications: theoretical feasibility and prototype results,” *IEEE Commun. Mag.*, vol. 52, no. 2, pp. 106–113, Feb. 2014.
- [26] P. Xingdong, H. Wei, Y. Tianyang, and L. Linsheng, “Design and implementation of an active multibeam antenna system with 64 RF channels and 256 antenna elements for massive MIMO application in 5G wireless communications,” *China Commun.*, vol. 11, no. 11, pp. 16–23, Nov. 2014.
- [27] M. A. B. Abbasi, H. Tataria, V. Fusco, and M. Matthaiou, “Performance of a 28 GHz two-stage rotman lens beamformer for millimeter wave cellular systems,” in *Proc. 13th EuCAP*, Krakow, Poland, Apr. 2019.
- [28] J. Wang, H. Zhu, N. J. Gomes, and J. Wang, “Frequency reuse of beam allocation for multiuser massive MIMO systems,” *IEEE Trans. Wirel. Commun.*, vol. 17, no. 4, pp. 2346–2359, Apr. 2018.
- [29] J. Puskely, Y. Aslan, A. Roederer, and A. Yarovoy, “SIW based antenna array with power equalization in elevation plane for 5G base stations,” in *Proc. 12th EuCAP*, London, UK, Apr. 2018.
- [30] C.-S. Park, Y.-S. Byun, A. M. Bokiye, and Y.-H. Lee, “Complexity reduced zero-forcing beamforming in massive MIMO systems,” in *Proc. IEEE ITA Workshop*, San Diego, CA, USA, Feb. 2014.
- [31] G. Adamidis and I. Vardiambasis, “Smart antenna design and implementation: A simple switched-beam antenna array based on a 8x8 butler-matrix network,” in *Proc. 10th WSEAS ICCOM*, Athens, Greece, Jul. 2006.
- [32] Y. Aslan, J. Puskely, A. Roederer, and A. Yarovoy, “Trade-offs between the quality of service, computational cost and cooling complexity in interference-dominated multi-user SDMA systems,” *IEEE Trans. Wirel. Commun.*, Feb. 2019, submitted for publication.
- [33] Y. Aslan, J. Puskely, J. H. J. Janssen, M. Geurts, A. Roederer, and A. Yarovoy, “Thermal-aware synthesis of 5G base station antenna arrays: an overview and a sparsity-based approach,” *IEEE Access*, vol. 6, pp. 58 868–58 882, Oct. 2018.
- [34] T. Azar, “Overlapped subarrays: review and update,” *IEEE Antennas Propag. Mag.*, vol. 55, no. 2, pp. 228–234, Apr. 2013.