



# LUND UNIVERSITY

## Activity Report: Automatic Control 2008

Westin, Eva; Hägglund, Tore

2009

*Document Version:*

Publisher's PDF, also known as Version of record

[Link to publication](#)

*Citation for published version (APA):*

Westin, E., & Hägglund, T. (Eds.) (2009). *Activity Report: Automatic Control 2008*. (Annual Reports TFRT-4036). Department of Automatic Control, Lund Institute of Technology, Lund University.

*Total number of authors:*

2

### General rights

Unless other specific re-use rights are stated the following general rights apply:

Copyright and moral rights for the publications made accessible in the public portal are retained by the authors and/or other copyright owners and it is a condition of accessing publications that users recognise and abide by the legal requirements associated with these rights.

- Users may download and print one copy of any publication from the public portal for the purpose of private study or research.
- You may not further distribute the material or use it for any profit-making activity or commercial gain
- You may freely distribute the URL identifying the publication in the public portal

Read more about Creative commons licenses: <https://creativecommons.org/licenses/>

### Take down policy

If you believe that this document breaches copyright please contact us providing details, and we will remove access to the work immediately and investigate your claim.

LUND UNIVERSITY

PO Box 117  
221 00 Lund  
+46 46-222 00 00

*Automatic Control 2008*



Activity Report

# Automatic Control 2008

Department of Automatic Control  
Lund University  
Sweden

**Mailing address**

Department of Automatic Control  
Lund University  
Box 118  
SE-221 00 LUND, SWEDEN

**Visiting address**

Institutionen för Reglerteknik  
Lunds universitet  
Ole Römers väg 1. LUND

**Telephone**

Nat 046 - 222 87 80  
Int +46 46 222 87 80

**Fax**

Nat 046 - 13 81 18  
Int +46 46 13 81 18

**Generic e-mail address**

control@control.lth.se

**WWW and Anonymous FTP**

<http://www.control.lth.se>  
<ftp://ftp.control.lth.se/pub>

This report was edited by Eva Westin and Tore Hägglund with great assistance from Leif Andersson.

Printed in Sweden  
Mediatryck, Lund, April 2009

ISSN 0280-5316  
ISBN LUTFD2/TFR--4036--SE

# Contents

1. Introduction 6
2. Internet Services 9
3. Economy and Facilities 10
4. Education 13
5. Research 16
6. External Contacts 56
7. Dissertations 58
8. Honors and Awards 63
9. Personnel and Visitors 64
10. Staff Activities 68
11. Publications and Conference Contributions 85
12. Reports 91
13. Lectures by the Staff Outside the Department 96
14. Seminars at the Department 102

# 1. Introduction

This report covers the activities at the Department of Automatic Control at Lund University from January 1 to December 31, 2008. This has been a year with several good news and nice events. We got a Linnaeus grant from the Swedish Research Council, which increased our research budget with about 40%. This has resulted in an increasing number of employees, a number that previously has been fairly constant for many years. We are now around 45 people working at the department. The number of visitors, both long term and short term, is also increasing, mainly because of the Linnaeus grant.

Because of the renovation of our building and offices, the major part of our department had to move to temporary offices during a large part of the year. This caused some extra efforts, and problems too, but now we are happy to be back in our old and newly renovated offices again.

We teach undergraduate courses in almost all engineering programs at the university. This year we gave 12 courses to 756 students, and 30 students presented their master's thesis at our department. The total teaching effort corresponds to 108 full-year equivalents. More details about the education at the department are given in Chapter 4.

Three PhD thesis were defended this year, by Brad Schofield, Peter Alriksson, and Andreas Wernrud. This brings the total number of PhDs graduating from our department to 84. Maria Karlsson and Toivo Henningsson both defended their licentiate theses during 2008, which gives a total number of 58 licentiate theses defended at the department. Seven PhD students were admitted this year; Philip Reuterswård, Fredrik Ståhl, Marzia Cescon, Daria Madjidian, Vanessa Romero Segovia, Magnus Linderöth, and Kristian Soltesz.

Three persons with doctor's degree left the department; Andreas Wernrud who now works for FOI in Linköping, Brad Schofield who started to work for Modelon AB in Gothenburg, and Peter Alriksson who is now at Ericsson in Lund. In November a new administrator, Eva Westin, became a member of our staff.

During 2008 the department hosted three international meetings: The DIAdvisor meeting on July 1, the SMERobot WPR4 workshop on October 28, and the Aeolus meeting on November 13-14.

The main part of this report consists of a description of current research at the department. Chapter 5 describes most of the research projects under the following headlines: Modeling and Control of Complex Systems, Control and Real-Time Computing, Process Control, Robotics, Automotive Systems, and Biomedical Projects. The following chapters give more details about staff activities and publications.

A summary of the publications from the department is given by the following table:

	<b>04</b>	<b>05</b>	<b>06</b>	<b>07</b>	<b>08</b>	<b>Sum</b>
<b>Books</b>	0	1	1	1	3	6
<b>Articles</b>	16	21	19	19	21	96
<b>Conference papers</b>	47	33	53	32	33	198
<b>PhD theses</b>	3	2	3	5	3	16
<b>Licentiate theses</b>	2	3	3	0	2	10
<b>Master's theses</b>	18	27	20	24	24	113
<b>Internal reports</b>	8	2	4	5	3	22

To give a perspective, the table shows the publications from the last five years. It shows that the publication rate has been fairly constant during the years. However, mainly because of the Linnaeus grant we expect an increase in publications in the years to come.



On the occasion of Björn Wittenmark's retirement, a symposium with international researchers and old and new colleagues and friends was organized on October 23. It had about 120 participants and ended with a memorable gala dinner at the main university building. Perhaps because of this, Björn's retirement was postponed one year.





One of our administrators, Agneta Tuszynski, retired last year after 27 years at the department. Agneta was responsible for the student administration and, among other things, the writing of these annual reports. Thank you, Agneta, for all the work you have done for this department!

## Acknowledgements

We want to thank our main sponsors:

VINNOVA (The Swedish Agency for Innovation Systems), VR (The Swedish Research Council), The European Commission, SSF (Swedish Foundation for Strategic Research), Volvo Powertrain, KCFP (Competence Center Combustion Processes), ABB Robotics, ABB Corporate Research, Gudel AG, Castings Technology International.

## 2. Internet Services

### World Wide Web

Visit our homepage at this address:

`http://www.control.lth.se`

Our website contains information about personnel, research, publications, seminars, education etc. It also contains fairly complete lecture notes for many courses, and in some cases software tools such as Matlab tool-boxes developed at the department. Our home-page first appeared on the World Wide Web (WWW) in April 1994.

### Electronic Mail

All personnel can be contacted by electronic mail. A personal email address consists of the full name and the department address in the following form:

`firstname.lastname@control.lth.se`

Double names are separated by underline, hyphens are treated as ordinary characters and accents are ignored. Examples:

`anders.rantzer@control.lth.se`  
`karl-erik.arzen@control.lth.se`

Our web page

`http://www.control.lth.se/people/telemail.html`

contains a complete list of email addresses and phone numbers. The department also has a generic email address:

`control@control.lth.se`

Emails to this address are continuously read by the postmaster and forwarded to the appropriate receiver.

# 3. Economy and Facilities

The turnover for 2008 was 29,5 MSEK. The income comes from Lund University (49%) and from external grants (51%). The distribution is shown below.

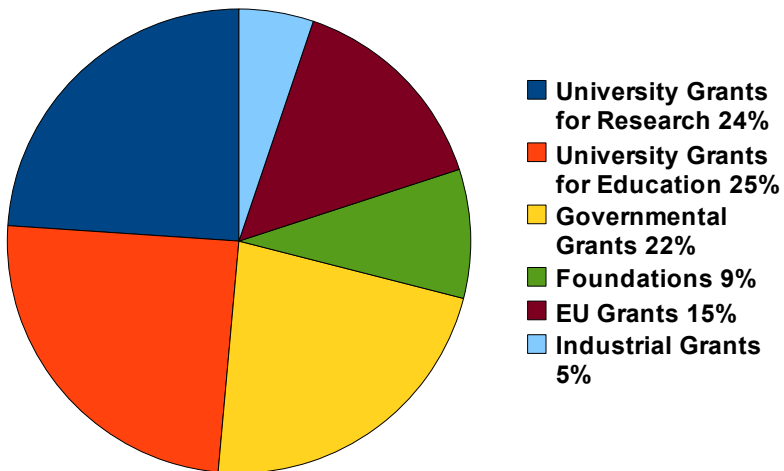

## Funding

Lund University provides most of the support for graduate students. Our research is externally funded from governmental agencies and industry. During 2008 we had the following contracts:

- VR – Control of Complex and Nonlinear Systems (block grant)
- VR – Active Control of Compressor Systems Based on New Methods of Nonlinear Dynamic Feedback Stabilization
- VR – Modelling and Control of Server Systems

- VR – Decentralized Structures for Industrial Control II
- VR – Periodic and Event-Based Control over Networks
- VR – Linnaeus grant Lund Center for Control of Complex Engineering Systems, LCCC
- VINNOVA – Diesel-HCCI in Multi-Cylinder Engines, together with Volvo Powertrain Corporation
- VINNOVA-Ericsson – Feedback Based Resource Management and Code Generation for Soft Real-Time Systems
- VINNOVA – 2006-03689 ITEA – European Leadership in System Modeling and Simulation through advanced Modelica Libraries
- SSF – Center for Chemical Process Design and Control (CPDC)
- SSF – Decentralized Control of Complex Systems, Senior Individual Grant, SIG, Anders Rantzer
- EU – IST-004536 Reconfigurable Ubiquitous Networked Embedded Systems (RUNES)
- EU – IST-004175 Complex Embedded Automotive Control Systems (CemACS)
- EU – IST-004527 Embedded Systems Design (ARTIST2)
- EU – IST-511368 HYbridCONtrol – Taming Heterogeneity and Complexity of Networked Embedded Systems (HYCON)
- EU – IST-507728 EURON II NoE
- EU – NMP2-CT-2005-011838 The European Robot Initiative for Strengthening the Competitiveness of SMEs in Manufacturing (SMERobot)
- EU – ICT-216586 Adaptivity and Control of Resources in Embedded Systems ACTORS
- EU – ICT-216592 Personal Health Systems for Monitoring and Point-of-Care Diagnostics DIAdvisor
- EU – ICT-97518 ArtistDesign – Design for Embedded Systems ARTIST-DESIGN
- EU ICT-224428 Control of Heterogeneous Automation Systems: Technologies for Scalability, Reconfigurability and Security CHAT
- EU – ICT-224548 Distributed Control of Large-Scale Offshore Wind Farms project proposal AEOLUS

- ABB Automation Technology Products/Business Unit Robotics (Research Collaboration)
- Haldex Brake Products AB – PhD Research Projects
- Toyota Motor Corporation – Project on Nonlinear Model Reduction
- Swedish Energy Agency (STEM) – Competence Center Combustion Processes, KCFP
- STINT – Support visit to Korea
- Royal Physiographic Society – Scholarship
- Knut and Alice Wallenberg Foundation – Scholarship
- Hakon Hansson Foundation – Scholarship
- Royal Academy of Sciences – Scholarship
- Per Westling Foundation – Scholarship
- Foundation of Sigfrid and Wahlborg Nordkvist – Scholarship
- Ernhold Lundström Foundation – Scholarship

The block grant from VR and the CPDC grant from SSF and some of the VINNOVA projects are long range. Several projects do, however, have a duration of only two years. To match these with the duration of a PhD, which is much longer, we have an internal research planning that is much more long range and we are careful to bid on projects that fit our long range research plan. This has proven an efficient way to match short-term funding to long term planning.

## **Teaching Laboratory**

The teaching laboratories are based on desktop processes and personal computers. These laboratories are used in all our courses. The introductory courses give a heavy load on the teaching laboratories because of the large number of students. There are about 800 students per year in total in all our courses and on the average they spend about 15 hours each in the laboratories.

Since the introduction of the “Tickless Kernel feature” in Linux 2.6.17, we now run all the laboratories with a standard Linux kernel, since this is now capable of running control tasks in sub-millisecond range. The limiting factor is still the determinism of Simulink and Java respectively.

# 4. Education

## Engineering Program

The engineering education follows the central European systems with a five year program leading up to the degree “civilingenjör” (civ.ing.), which corresponds to an MSc in the US and British systems.

Automatic control courses are taught as part of the engineering curricula in Engineering Physics (F), Electrical Engineering (E), Computer Engineering (D), Mechanical Engineering (M), Information and Communication Engineering (C), Environmental Engineering (W), Engineering Mathematics (Pi), Industrial Management and Engineering (I), Biotechnology (B), Engineering Nanoscience (N) and Chemical Engineering (K). During 2008, 756 students passed our courses and 30 students completed their master's thesis projects. The number of registered students correspond to 108 full-year equivalents during the year. The numbers for 2008 were 790, 28 and 111 respectively.

Topics for the master's theses were in the following areas: Automotive Systems (7), Process Control (6), Robotics (6), Telecommunication (3), Climate Control (1) and Biotechnology (1). A list of the master's theses is given in Chapter 12.

In table 4.1 below, our courses are listed along with the number of students who passed each course.

**Table 4.1** Courses and the number of students who passed.

Reglerteknik AK FRT010 (Automatic Control, Basic Course)	424
Realtidssystem FRTN01 (Real-Time Systems)	60
Prediktiv reglering FRTN15 (Predictive Control)	22
Internationell projektkurs i reglerteknik FRT100 (International Project Course in Automatic Control)	0
Processreglering FRT081 (Process Control)	23
Reglerteori FRT130 (Control Theory)	12
Flervariabel reglering FRTN10 (Multivariable Control)	25
Systemidentifiering FRT041 (System Identification)	12
Systemteknik FRT110 (Systems Engineering)	78
Olinjär reglering och servosystem FRTN05 (Nonlinear Control and Servo Systems)	38
Projekt i reglerteknik FRT090 (Projects in Automatic Control)	0
Matematisk modellering FK FRT095 (Mathematical Modelling, Advanced Course)	69
Examensarbete FRT820 (Master's Thesis Project)	30

## Information on WWW

Most students have access to Internet via Lund University. Therefore we have made a great effort to present the education on web pages. Each course in the engineering program has its own homepage, documentation, manuals, old exams etc. We also have information sheets about the engineering courses, the master's theses and the doctorate program. You'll find the links at <http://www.control.lth.se/education/>.

## Doctorate Program

Three PhD Theses were defended this year by Brad Schofield, Peter Alriksson and Andreas Wernrud. This brings the total number of PhDs graduating from our department to 84. Abstracts of the theses are given in Chapter 7.

We have admitted Philip Reuterswärd, Fredrik Ståhl, Marzia Cescon, Daria Madjidian, Vanessa Romero Segovia, Magnus Linderoth and Kristian Soltesz as PhD students during the year.

The following PhD Courses were given during the year:

- Embedded Systems 2008 (Anton Cervin, Johan Åkesson, Karl-Erik Årzén)
- Convex Optimization with Applications (Kin Cheong Sou), 7,5 hp
- Distributed Control (Anders Rantzer), 3 hp
- Stochastic Control (Björn Wittenmark), 7,5 hp



# 5. Research

The goal of the department is to provide students with a solid theoretical foundation combined with a good engineering ability. This is reflected in the research program which covers both theory and applications. The major research areas are:

- Modeling and Control of Complex Systems
- Control and Real-Time Computing
- Process Control
- Robotics
- Automotive Systems
- Biomedical Projects

In July 2008, the department became host for a Linnaeus grant from the Swedish Research Council worth 75 MSEK over 10 years. The grant is used to fund a new center called LCCC – Lund Center for Control of Complex Engineering Systems. The main research areas of LCCC are illustrated in the picture below:

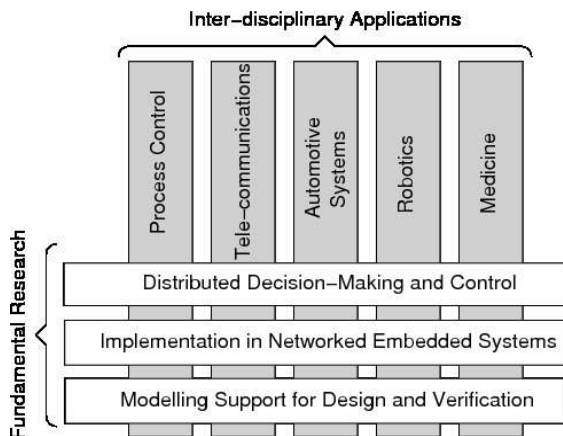

In the following presentation the research at Automatic Control LTH is in most cases broken down to the granularity of a PhD thesis. There are of course strong relations between the different projects.

# Modeling and Control of Complex Systems

Theory and computer tools are developed to deal with fundamental complexity issues appearing in for example vehicles, power systems and communications.

## Distributed Control of Complex Systems

*Researchers: Peter Alriksson, Pontus Giselsson, Karl Mårtensson, Daria Madjidian, Erik Johannesson and Anders Rantzer*

*Funding: SSF-Senior Individual Grant, Swedish Research Council*

How should control equipment distributed across the power grid in southern Scandinavia cooperate to quickly find new transmission routes when a power line is broken? How should the electronic stabilization programme (ESP) of a car gather measurements from wheels and suspensions and decide how to use available brakes and engine power to recover from a dangerous situation? How can a large number of sensors and actuators be coordinated to control the dynamics of a flexible mechanical structure?

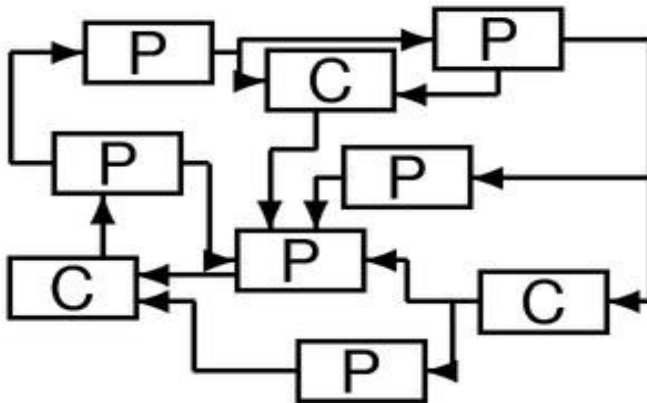

All these questions are examples of distributed control problems, where several controllers need to cooperate with access to different information and with bounds on the communication between them. Most of traditional control theory was developed with a centralized viewpoint. However, recently important steps were taken in the new direction of distributed control theory, building on a historical development dating back to economic game theory and statistical decision theory from the 1960s.

We are currently addressing these problems from a general system theoretic viewpoint, but with particular attention to the following three applications:

- Control of power networks
- Dynamic positioning of laboratory vehicles using sensor networks
- Control of buffer sizes in manufacturing systems

## AEOLUS - Distributed Control of Large-Scale Offshore Wind Farms

*Researchers: Daria Madjidian and Anders Rantzer in collaboration with project partners from Aalborg University, Industrial Systems and Control Ltd in Glasgow, University of Zagreb, Energy Research Centre of the Netherlands and Vestas Wind Systems A/S. Duration: May 2008 – April 2011*

*Funding: EU/IST/FP7*

Aeolus is an European research project funded by the European Commission under the IST framework programme 7 for Information and Communication Technology, ICT. The main goal of Aeolus is to research and develop models that allow real-time predictions of flows and incorporate measurements from a set of spatially distributed sensor devices. In Aeolus we will use the flow information as a basis for new control paradigms that acknowledge the uncertainty in the modelling and dynamically manage the flow resource in order to optimise specific control objectives.



November 14, 2008 Aeolus together with LCCC organized a Wind Power Meeting in Lund.

## CHAT - Control of Heterogeneous Automation Systems

*Researchers: Karl Mårtensson and Anders Rantzer in collaboration with project partners from University of Pisa, Siemens AG, University of Trento, University College London, Elsas Datamat, Sofidel and University of Salento. Duration: September 2008 – August 2011*

*Funding: EU/IST/FP7*

Scalability, reconfigurability, and security are three aspects of paramount importance in developing efficient, predictable, and safe control architectures for large-scale networked industrial automation. At present, the state of control systems technology is such that the supervision and control of larger and more complex plants cannot be achieved without considerable costs in terms of hard infrastructure and software development.

CHAT is a research project exploring the research and engineering challenges inherent in the development of algorithms, protocols and procedures for next generation distributed control systems, in order to drastically reducing infrastructure, maintenance and reconfiguration costs.

# Relaxed Dynamic Programming

*Researchers: Peter Alriksson, Andreas Wernrud and Anders Rantzer*

A new approach to synthesis of nonlinear and hybrid observers and controllers is currently developed by extending the classical idea of dynamic programming. This method was introduced by Bellman in the 1950's and has found many important applications since then. The idea is general and very simple, but the “curse of dimensionality” is often prohibitive and has previously restricted most applications to a discrete state space of moderate size. Our idea is to use a relaxed version of dynamic programming to find approximations of the cost function. It turns out that finding a solution which is guaranteed to be within 10% from the optimum can be much less expensive than finding one within 1%.

Our current research on this topic includes performance analysis in model-predictive control, optimal estimation using sensor switching and control synthesis for DC-DC converters.

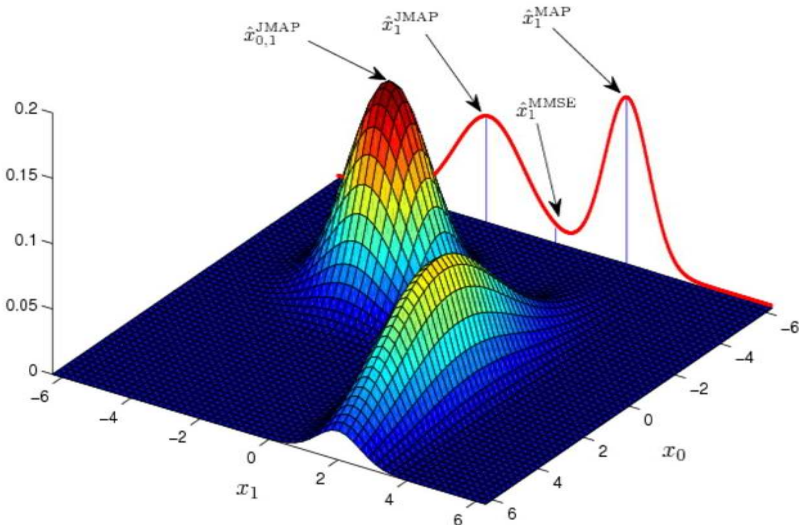

The figure above illustrates an example where the cost to go is computed backwards in time, starting at  $T=200$ . The three parameter values 1.01, 1.1 and 1.5 correspond to accuracies of 1%, 10% and 50% respectively.

ively. Notice that the size of the search tree first grows exponentially for time steps down to about  $T=180$ , then the size starts to shrink and finally stabilizes at a lower level that depends on the requested optimization accuracy.

## Modeling and Validation of Complex Systems

*Researchers: Oskar Nilsson, Aivar Sootla, Giorgos Kotsalis, Kin Cheong Sou and Anders Rantzer*

*Funding: Swedish Research Council, Toyota Motor Corporation*

Large complex mathematical models are regularly used for simulation and prediction. However, in control design it is common practice to work with as simple process models as possible. This makes it easier to analyze and evaluate the model, or to use it inside the controller for on-line estimation of important variables. One objective of this project is to develop methods and tools that can take a complex model and deduce simple models for various purposes and also to derive bounds on the approximation error.

One research approach is based on the method of balanced truncation and its extension to nonlinear and hybrid systems. Analysis is done based on linearization around simulated trajectories. Other approaches are based on semi-definite programming and frequency domain sampling. Special attention is given to component-wise reduction for models with block structure. Engine models from Toyota Motor Corporation are used as test cases.

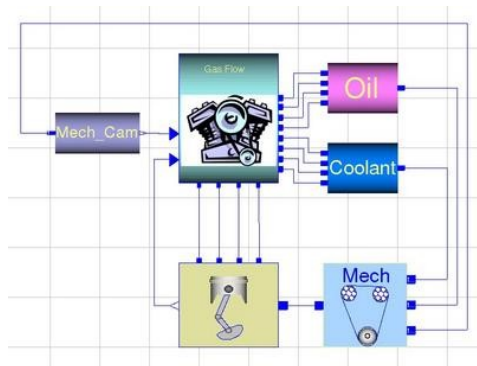

# Language Support for Dynamic Optimization

*Researchers: Johan Åkesson and Karl-Erik Årzén*

## *Overview*

Efficient development and operation of control systems is essential in industry today. Optimization is increasingly used as a standard tool to improve operation, both in on-line and off-line applications. Examples are calculation of operating points, grade change trajectories and production schedules that maximize production while minimizing raw material, energy and other resources. Similar issues arise in the design of embedded control systems for e.g., the automotive, avionics, and mobile telecom areas, where efficient utilization of computing, communication, and/or battery resources is required in order to meet market demands. This can also often be formulated as optimization problems.

Due to the ever increasing complexity of plants, a model-driven approach is required. At the heart of this project is a language-based approach for developing a high-level description framework targeted at unified modeling of physical systems and associated optimization problems. This also includes development of prototype software, which transforms a high-level description into a canonical mathematical model representation. This canonical representation may then be used as a basis for code generation for the above mentioned applications. The main topic of the project is the formulation of large-scale optimization problems. Associated with this topic is also code generation for numerical solvers.

## *Optimica*

A key issue is the definition of syntax and semantics of the Modelica extension, Optimica. Optimica provides the user with language constructs that enable formulation of a wide range of optimization problems, such as parameter estimation, optimal control and state estimation based on Modelica models.

At the core of Optimica are the basic optimization elements such as cost functions and constraints. It is also possible to specify bounds on variables in the Modelica model as well as to mark variables and parameters as optimization quantities, i.e., to express what to optimize over. While this type of information represents a canonical optimization formulation, the user is often required to supply additional information, related to the numerical method which is used to solve the problem. In this category we have e.g., specification of transcription method, discretiza-



tion of control variables and initial guesses. Optimica also enables convenient specification of these quantities.

### *Software Tools - the JModelica compiler*

In order to demonstrate the proposed concept, prototype software tools, referred to as JModelica, are being developed. In essence, the task of the software is to read the Modelica and Optimica source code and then translate, automatically, the model and optimization descriptions into a format which can be used by a numerical algorithm. The JModelica compiler is developed using the Java-based compiler construction tool JastAdd.

Currently, the front-end of the JModelica compiler supports a subset of Modelica and a basic version of Optimica. In addition, a code-generation back-end for AMPL has been developed. AMPL is a language intended for formulation of algebraic optimization problems. Accordingly, the compiler performs automatic transcription of the original continuous-time problem into an algebraic formulation which can be encoded in AMPL. In the transcription procedure, the problem is discretized by means of a simultaneous optimization approach based on collocation over finite elements. Finally, the automatically generated AMPL description may be executed and solved by a numerical NLP algorithm. For this purpose we have used IOPT.

The JModelica software is currently being developed with the objective of releasing it as open source software. As part of this work, the compiler is extended with a code generation back-end for C, which will eliminate the need for AMPL, which is a commercial software. In addition, ongoing work integrates the JModelica software into a Python environment in order to enable convenient scripting. See [www.jmodelica.org](http://www.jmodelica.org) for more information.

### *Case Studies*

The prototype tools have been used to formulate and solve a start-up problem for a plate reactor system. The plate reactor is conceptually a tubular reactor located inside a heat exchanger, and offers excellent flexibility, since it is reconfigurable and allows multiple injection points for chemicals, separate cooling/heating zones and easy mounting of temperature sensors. In this case study, an exothermic reaction,  $A+B \rightarrow C$ , was assumed. The reactor was fed with a fluid with a specified concentration of the reactant  $A$ . The reactant  $B$  was injected at two points along the reactor.

The primary objective of the start-up sequence was to transfer the state of the reactor from an operating point where no reaction takes place, to the desired point of operation. This problem is challenging, since the dynamics of the system is fast and unstable in some operating conditions. In addition, the temperature in the reactor must be kept below a safety limit, in order not to damage the hardware.

Optimal control and state profiles were calculated off-line and then used as feedforward and feedback signals in a PID-based mid-ranging control system.

The experiences from using the JModelica compiler in this project are promising, in that the tools enable the user to focus on *formulation* of the problem instead of, which is common, *encoding* of the problem.

The JModelica compiler is also used in two Master's thesis projects, which concerns optimization of dynamic vehicle models. The first project deals with race track optimization, where the problem is to minimize the lap time given the track curvature and a dynamic vehicle model. In the second project, the problem being studied is calibration of simple vehicle models.

## Inducing Stable Oscillations in Nonlinear Systems by Feedback

*Researchers: Rolf Johansson and Anders Robertsson in cooperation with Prof. A. Shiriaev, Umeå University, Swedish Research Council 2006-2008, Ref. 2005-4182*

The aim of this project is to develop feedback control laws for nonlinear dynamical systems represented by the classical Euler-Lagrange equations. We consider the systems with the number of actuators being less than the number of its degrees of freedom (DOF) by one. Examples of such dynamical systems are ubiquitous, for instance, a cart-pendulum system (2 DOF correspond to position of the cart and angle of the pendulum, 1 actuator produces the force applied to the cart) and a ship on a plane (3 DOF; 2 actuators). The two problems, approached in the project, are: how to derive a simple and efficient algorithm of motion planning for such a under-actuated systems and how to make a pre-planned motion orbitally stable in the closed loop. It is well known that feedback control design for under-actuated systems is inherently difficult task since not every desired motion is feasible for a system with not actuated DOF. Our controller design approach is based on the idea of virtual

holonomic constraint: geometrical relations imposed between generalized coordinates, which are made invariant for the closed loop system. Exploiting this idea, we have obtained series of preliminary results, in particular, on reducibility of dynamics, integrability of zero dynamics, extension of the famous Lyapunov lemma on presence of center in a nonlinear system, constructive procedure for exponential orbital stabilization of pre-planned motions, extensions to hybrid dynamical systems.

## Active Control of Compressor Systems Based on New Methods of Nonlinear Dynamic Feedback Stabilization

*Researchers: Rolf Johansson and Anders Robertsson in cooperation with Prof. A. Shiriaev, Umeå University, Swedish Research Council 2007-2009, Ref. 2006-5243*

This project deals with a number of facts related to the output feedback stabilization of the Moore-Greitzer compressor model. We show that quadratic feedback stabilization of the surge subsystem of the three-state Moore-Greitzer compressor model, which ensures an absence of additional equilibria in the augmented with stall dynamics closed loop system, implies convergence of all solutions to the unique equilibrium at the origin. Then some steps in developing such output feedback controller for surge subsystem are discussed, and a family of controllers is presented. Based on our new theoretical results on integrability, stability, nonlinear dynamic output feedback control, we wish to pursue active control application to compressor systems and experimental verification.

# Control and Real-Time Computing



## Adaptivity and Control of Resources in Embedded Systems (ACTORS)

*Researchers: Mikael Lindberg, Anton Cervin, and Karl-Erik Årzén in collaboration with the other 6 core partners. Duration: February 2008 – January 2011*

*Funding: EU/IST/FP6 STREP*

ACTORS is an EU/IST FP7 STREP on feedback-based resource management and data-flow modeling in embedded systems. The other partners in the project are:

- Ericsson (Coordinator) – Johan Eker
- Scuola Superiore Sant'Anna di Pisa – Giorgio Buttazzo
- TU Kaiserslautern – Gerhard Fohler
- Ecole Polytechnique Fédérale de Lausanne – Marco Mattavelli
- Evidence Srl – Paolo Gai
- AKAtch SA – Vincent Noel
- Xilinx – Jörn W. Janneck

## Feedback Based Resource Management and Code Generation for Soft Real-Time Systems (FISS2)

*Researchers: Mikael Lindberg, Anton Cervin, and Karl-Erik Årzén in collaboration with Ericsson. Duration: Spring 2007 - Dec 2009*

*Funding: VINNOVA via Ericsson*

FISS2 is an VINNOVA/Ericsson project within the so called Swedish Telecom-initiative. The topic of the project is reservation and feedback resource management in mobile multimedia terminals.



## Design of Embedded Systems (ARTIST2)

*Researchers: Toivo Henningsson, Mikael Lindberg, Martin Kjaer, Anders*

*Robertsson, Anton Cervin, and Karl-Erik Årzén in collaboration with the other partners of the ARTIST2 NoE. Duration: September 2004 – August 2008*

*Funding: EU/IST/FP6*

ARTIST2 is an EU/IST FP6 network of excellence on design of embedded systems. The objective of ARTIST2 is to strengthen European research in Embedded Systems Design, and promote the emergence of this new multi-disciplinary area. ARTIST2 gathers together the best European teams from the composing disciplines, and will work to forge a scientific community.

Internally ARTIST2 is divided into seven clusters (Modelling and Components, Hard Real-Time, Adaptive Real-Time, Compilers and Timing Analysis, Execution Platforms, Control for Embedded Systems, Testing and Verification). Lund is a member of the cluster Control for Embedded Systems with Karl-Erik Årzén as the cluster leader. The other nodes in this cluster are KTH, Czech Technical University, and the Polytechnical University of Valencia. The work within the cluster is focused on three areas:

- Control of Real-Time Computing Systems
- Real-Time Techniques in Control System Implementation
- Co-Design Tools for Control, Computing, and Communication

During 2007 the two following main events were organized by the cluster:

- Graduate course on Embedded Control, Lund, 7-11 May
- 2nd International ARTIST Workshop on Control for Embedded Systems, Univ of Illinois, Urbana-Champaign, May 31-June 1, 2

During 2006 the following events were organized by the cluster:

- Graduate course on Embedded Control, Prague, 3-7 April
- Invited session on co-design tools at the IEEE CACSD conference, Munich, Oct 5
- Co-organized the First European Laboratory on Real-Time and Control for Embedded Systems, July 10-14th, 2006, Pisa, Italy

- The workshop Interaction between control and embedded electronics in the automotive industry was jointly organized in Innsbrück, March 23
- The Scandinavian ARTIST2 Day in Stockholm, 21 August

## Design of Embedded Systems (ArtistDesign)

*Researchers: Toivo Henningson, Mikael Lindberg, Anders Robertsson, Anton Cervin, and Karl-Erik Årzén in collaboration with the other 31 core partners of the EU IST FP7 ArtistDesign Network of Excellence. Duration: January 2008 – December 2011*

*Funding: EU/IST/FP7*

ArtistDesign is an EU/IST FP7 network of excellence on design of embedded systems. It is a follow-up project to the FP6 NoE Artist2. The objective of ArtistDesign is to strengthen European research in Embedded Systems Design, and promote the emergence of this new multi-disciplinary area. ArtistDesign gathers together the best European teams from the composing disciplines, and will work to forge a scientific community.

Internally ArtistDesign is divided into four thematic clusters (Modeling and Validation; SW Synthesis, Code Generation and Timing Analysis; Operating Systems and Networks, and Hardware Platforms and MPSoC Design) and one transversal integration cluster. Lund is a member of the Operating Systems and Networks cluster. Karl-Erik Årzén is also the leader of the Design for Adaptivity activity within the integration cluster.

## EUROSYSLIB

*Researchers: Philip Reuterswård, Anton Cervin, and Karl-Erik Årzén in collaboration with Dynasim. Duration: Summer 2007 - December 2009*

*Funding: ITEA2/VINNOVA*

The ultimate objective of EUROSYSLIB is to make Modelica the de-facto standard language for embedded system modelling and simulation. In order to support this major product lifecycle management effort, the EUROSYSLIB consortium, composed of 20 European partners, is committed to delivering a large set of high-value, innovative modelling and simulation libraries based on the freely available Modelica object-oriented modelling language. The role of Lund University is to develop a network simulation library for Modelica with features that are similar to

the network blocks in the TrueTime simulator developed at Lund University.

## LUCAS Center for Applied Software Research

*Researchers: Karl-Erik Årzén, Rolf Johansson, Anders Robertsson, Anton Cervin, Dan Henriksson, Martin Ohlin, Anders Blomdell, and Leif Andersson in collaboration with Department of Computer Science and industry.*

The Center for Applied Software Research (LUCAS) is a collaboration between the software-oriented parts of two departments at LTH: Computer Science and Automatic Control.

In total around 15 faculty members and 20 PhD students are involved in LUCAS. The focus of LUCAS is industrially-oriented and motivated software research. This includes research on software engineering, software technology, and software applications. Special focus is put on real-time systems, in particular embedded systems, networked systems, and control systems. The work is organized along three thematic areas:

- Software Engineering Environments
- Methods in Software Engineering
- Real-Time Systems Software

The first thematic area focuses on the core areas of integrated environments (tools and methods), object-oriented languages in the tradition of Simula, Beta, and Java, and embedded systems. The research method is focused on experimental implementation and development of relevant theory. Examples of issues that are studied are configuration management, collaboration support, domain-specific languages, frameworks and patterns and Java for embedded systems. The second thematic area is focused on software development processes, methods and architectural issues for development and maintenance of complex software systems. More specifically, the research is directed towards the following key areas: software quality, verification and validation, requirements engineering, and software process architectures. The research is approached through empirical studies to understand, assess, and improve software development. The third thematic area is focused on the software aspects of real-time systems, in particular embedded system, networked systems,

and control systems. Some examples of topics within the area are real-time kernels and run-time systems for embedded systems, system architectures for real-time control systems in e.g., industrial automation and robotics, integrated approaches to control design and CPU and communication bandwidth scheduling, and verification and validation of real-time systems.

The activities within LUCAS consist of research projects in collaboration with industry, center activities, and teaching activities. The projects can span the full range of LUCAS or be focused on one of the thematic areas. The aim of the center activities is to maintain the infrastructure of LUCAS and to disseminate information among the partners. The teaching activities include both graduate-level courses and continued education courses.

Industries can join LUCAS at three levels of participation. A gold member is involved in projects over the full range of LUCAS and has a long-term strategic interest in the activities of LUCAS. Silver participants are involved in a single research project, whereas bronze members have access to the LUCAS network in terms of seminars, tutorials, courses, and workshops.

## Control of Computer Server Systems

*Researchers: Anders Robertsson, Martin Ansbjerg Kjær, Karl-Erik Årzén, and Björn Wittenmark, in cooperation with Maria Kihl and Mikael Andersson, Department of Electrical and Information Technology, Lund University. Dan Henriksson graduated during 2006 and was for the academic year 2006/2007 postdoc at UIUC, working in cooperation with Lui Sha and Tarek Abdelzaher, Department of Computer Science, University of Illinois Urbana Champagne. Mikael Andersson defended his PhD thesis in May 2007.*

We are working on control of network server systems along two parallel lines.

### *Admission Control*

In this project we consider modeling of network service control nodes and the use of nonlinear control theory for analysis and design of admission control schemes.

In the last couple of years “Communication and Control” has gained large attention and a lot of new research has focused on control of and



over networks. However, the admission control problem, which is important for the utilization and the robustness of the network still remains as an rather unexplored area. Here, we believe the interaction of queuing theory and nonlinear control play a major role.

During the project modelling for prediction and control of server nodes has been found which aligns well with the properties of the discrete-event models from the queuing theory. The different control algorithms and the effect of different arrival and service process distributions are evaluated experimentally on an Apache web server in a laboratory network. A traffic generator is used to represent client requests. The control of the Apache server has been re-written to implement our algorithms. We show that the control theoretic model aligns well with the experiments on the web-server. Stability analysis and controller design for both continuous and discrete-time models are considered.

### *Service Rate Control*

In a collaboration with Tarek Abdelzaher at Univ of Virginia (currently at Univ of Illinois) we study service rate control of web-servers. An control scheme based on feedforward using an instantaneous queue model together with event-based PI feedback has been developed.

## Periodic and Event-Based Control over Networks

*Researchers: Anton Cervin, Toivo Henningsson, Erik Johannesson and Karl Johan Åström*

In this project, we investigate the timing aspects of networked control and focus on the interplay between network scheduling and control performance. We study the fundamental trade-offs that exist between sampling rates, delays, and jitter in networked control. We want to be able to answer questions such as “What level of control performance can be achieved using time-triggered vs priority-based communication protocols?”, “How can impact of network-induced jitter be handled in control design?”, and “How can primitives suitable for control be included in existing and new communication protocols?”

A very promising approach to more efficient usage of the network bandwidth is event-based control. The idea is to communicate measurement and control signals only when something unexpected and significant has happened in the system. We are investigating how this approach

compares to ordinary, periodic control, and how event-based sampling and control can be incorporated in network scheduling algorithms.

During 2008, we have investigated how to schedule multiple time-triggered or event-triggered controllers on a shared network. We have found that sporadic event-triggered sampling and communication go well together and give better performance than time-triggered schemes. In a case study on first-order plants we have shown that results hold independent on the specific network access method used (random, static priority, or dynamic priority).

In November 2008, Toivo Henningson presented his licentiate thesis on event-triggered control and estimation. Apart from the work on sporadic event-based control mentioned above, the thesis deals with estimators for systems with quantized measurements. Several different estimators are developed and compared with regard to complexity and performance. A mixed observer has been developed that is able to combine stochastic and set-bounded (worst-case) disturbance descriptions. In a practical case study, we have also experimented with event-based velocity control of a moving cart with quantized position measurements.

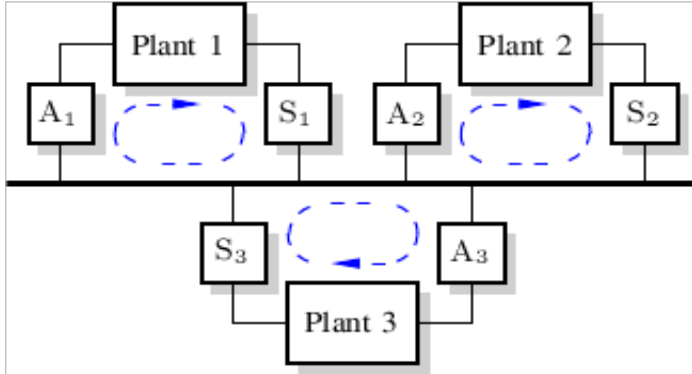

Multiple event-triggered controllers sharing a communication network.

# Process Control

## PID Control

*Researchers: Karl Johan Åström, Olof Garpinger, Tore Hägglund, and Per-Ola Larsson*

This project has been in progress since the beginning of the eighties, and resulted in industrial products as well as several PhD theses. Three monographs on PID control that are based on experiences obtained in the project have also been published. The last is “Advanced PID Control”, published in 2005. The research is currently focused on the following topics:

### *A Simple Dead-Time Compensator*

In this part of the project we are considering an ordinary PI(D) controller extended with a dead time compensator structure similar to a Smith predictor. The motivation for the project is that this new controller structure may be as easy to tune as a PI(D) controller, provided that model-based tuning rules are used. The performance of the new controller will be compared with the performance of the PID controller. The closed loops will be required to fulfill certain degrees of robust stability and performance and have a limit on control signal variance induced by measurement noise. The minimization criteria at the controller design is the integrated absolute error (IAE).

### *Relation Between Control Signal Properties and Robustness Measures*

In a realistic setting, fast response to load upsets are restricted by e.g. limitations on actuator devices, noise characteristics of measured signals, and process variations. Thus, this should be incorporated in the design of a controller. An analysis concerning the optimization constraint in the PID design in this project and in the project “Decentralized Structures for Industrial Control” has been performed. It has shown that analytical expressions relating the  $M_S$  and  $M_T$  circles and the control signal magnitude and activity exist to a certain extent. Large robustness margins give small control signal activities and the opposite holds for small ro-

bustness margins. Thus, the proposed PID parameter optimization do take required control signal properties into consideration.

### *Software Tools for Design of PID Controllers*

A new, interactive and easily modifiable software tool for robust PID design has been developed at the department. The tool has been programmed in Matlab and the goal is to find the controller that minimizes the IAE value during a load disturbance, while applying robustness constraints in terms of M-circles. The program has been made with focus on being user-friendly as well as robust and will hopefully be included in an educational autotuner in the future. The figure on this page shows a plot from the program, depicting the IAE cost as a function of the integral time and the derivative time in a PID controller. The minimum is shown by the yellow mark in the figure.

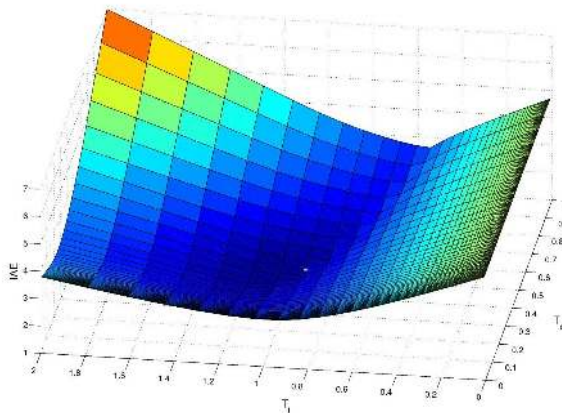

Surface plot from the PID design tool

The current research aims at making the software more suitable for the purpose of controlling real plants. This is done by including tuning of the time constant of a lowpass filter which the measurement signal is fed through. The purpose is to set a bound on the variance of the control signal, induced by measurement noise. By this modification, we hope to make it easier to include the D-part without fear of a noisy control signal wearing on the actuators. The D-part, however, should only be used if it

is justified. In many cases, a PI controller has been shown to be quite sufficient. In the future we hope to give a general idea for which types of processes a PI or PID controller are performing well compared to more advanced controllers. This will also be related to the amount of control signal noise we allow.

PID Design Tool for Matlab is available for downloading at <http://www.control.lth.se/user/olof.garpinger/>.

### *Interacting Learning Modules for PID Control*

We are also developing interactive learning modules for PID control. The modules are designed to speed up learning and to enhance understanding of the behaviour of loops with PID controllers. The modules are implemented in SysQuake, and the work is done in collaboration with professor Sebastián Dormido at UNED, Madrid, and José Luis Guzmán at Universidad de Almería. The tools can be downloaded at <http://aer.ual.es/ilm/>.

## Decentralized Structures for Industrial Control

*Researchers: Olof Garpinger and Tore Hägglund*

There is an unfortunate gap between the centralized computational approaches of multi-variable control theory and the common practice to design local control loops disregarding couplings and interaction. Today it appears that both approaches has reached a point of refinement where the gap can be reduced from both sides.

This project aims to revise and improve the basic modules for decentralized control, and to develop new. By increasing the performance of the modules, the usefulness of present MIMO control functions such as MPC will increase. In this way, we will try to decrease the gap between MIMO control functions and the state of the art of process control. The ideas to be investigated in this project are relevant not only for process control but is also of interest for general classes of multi-variable systems.

In a first stage, we will develop a new module building on experiences from PID control: a TITO controller, i.e. a controller with two inputs and two outputs. To be accepted in process control, the TITO controller will be fully automatic without any parameters to be set by the user. It means that an automatic tuning procedure has to be developed.

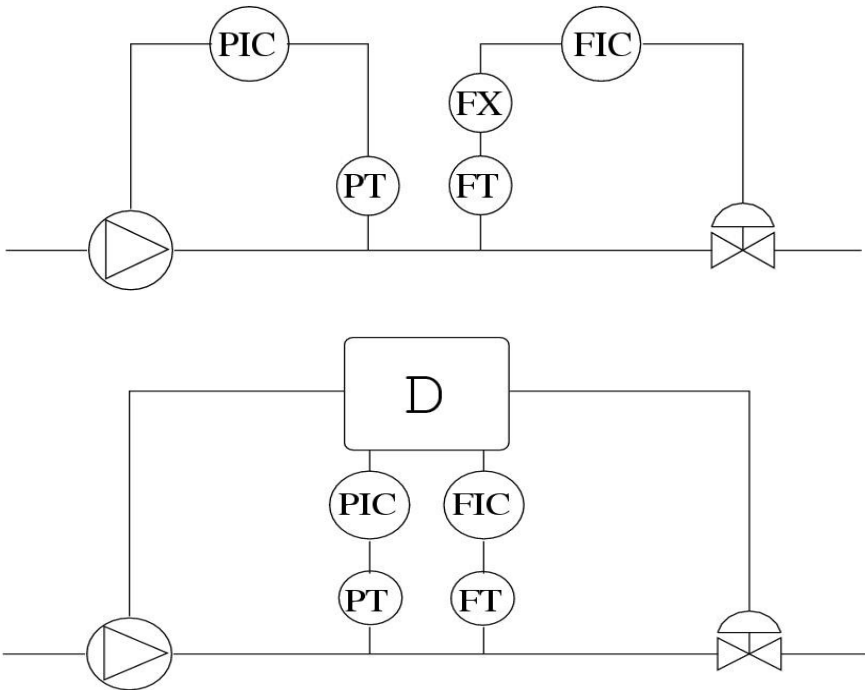

Conventional control of coupled systems (upper) and control with decoupling (lower).

In a first phase, a decoupling procedure and a new PID design method have been developed. The decoupler is dynamic, but the goal has been to introduce as little dynamics in the decoupler as possible. Traditional PID design methods are not suitable for decoupled systems. For this reason, a new design method based on exhaustive search has been derived. The work in this first phase has resulted in a licentiate thesis by Pontus Nordfeldt.

During 2008, the work has been focused on the PID design method and the software has been developed considerably. This part of the project is presented in more detail in the project "PID Control". Collaboration with ABB has also been extended through a master-thesis project dealing with implementation aspects.

The project is funded by The Swedish Research Council (VR).

# Performance Monitoring and Diagnosis

*Researchers: Tore Hägglund and Per-Ola Larsson*

## *A Performance Index Based on Control Specifications*

In the summer 2007, a new project concerning diagnosis of control loops was initiated. The diagnosis is built around a so called performance index that indicates the health of the loop. A majority of the today available performance indices are related to optimal performance of the loop, with some underlying criteria such as minimum variance and LQG-control. In many situations it is impossible to meet such an optimal criteria due to e.g. lack of process knowledge, requirements of a too heavy control signal activity, and restricted control structure. Instead, the aim of this ongoing project is to develop a performance index that is related to a specified satisfying control performance that is possible to meet. The initial tuning of the loop is used as reference in the index calculation. Although, explicit controller structure and parameters are not to be known by the index algorithm, neither is any a priori knowledge of the process assumed available. In the project, it has been shown that modeling of the closed loop using only process output data, gives an opportunity to calculate such an index.

## *Backlash Estimation*

Stiction and backlash in control valves are the major problem at the loop level in process control plants. There are two aspects of the problem. First of all, the nonlinearities deteriorate the control performance. Secondly, the loops facing these problems often remain undiscovered by the personnel in process control plants. There are several procedures for automatic stiction detection available and used in industrial plants today.

A new method for detection and estimation of backlash in control loops has been developed. The detection procedure is based on normal operating data. It is not assumed that the output from the backlash is measured. The procedure is automatic in the sense that no information has to be provided from the user to run the procedure. Since an estimate of the dead band caused by the backlash is provided by the procedure, the procedure gives all information needed to compensate for the backlash. The procedure has been tested in industry and a MS project has been performed in collaboration with ABB to prepare for implementation in an industrial DCS system. The method is patented.



## Process Industrial Centre at Lund University

*Researchers: Johan Åkesson, Tore Hägglund and Charlotta Johnsson*

With support from the Swedish Foundation for Strategic Research (SSF), a new centre, PIC-LU, has been established in collaboration with the department of Chemical Engineering.

The overall goal of PIC-LU is to establish, in cooperation with Swedish process industry, an internationally leading center for research and professional training in process optimization and control.

In the research program, methodology and tools for modelling, optimization, and control of industrial processes will be developed, in order to improve production systems with respect to flexibility, controllability, and availability. The methodology and the tools are developed from specific solutions to process control problems suggested by the industrial partners. The goal is to make the results from PIC-LU industrially relevant, not only for the participating industries, but on a wide scale in process operation and automation. The first industrial partners are Borealis, Novo Nordisk, Perstorp, and Pfizer.

In the competence development program, the main goal is to increase the competence level of process optimization and control in industry as well as in academy. The goal will be reached in two ways; through an educational program at different levels for staff in process industry, and by directed efforts in MSc and PhD programs at the university.



## Robotics

Robotics offers both theoretical and practical challenges. Robotics is a multi-disciplinary topic and we collaborate with both national and international robotics colleagues regarding different aspects of robotics and we also have a close cooperation with industrial partners. Our main research are in motion and compliance control, control system architectures and different sensor fusion problems with application mainly to industrial manipulators. We use mainly modified and extended ABB robot control systems as experimental platforms.

The laboratory for robotics and real-time systems is centered around industrial manipulators with open control system architectures. In the lab we have an ABB IRB6 robot, an ABB IRB2000 robot, an ABB Irb2400 (S4C+) and an ABB IRB140 (IRC5). Hardware interfaces have been developed to create an open system suitable for control experiments. The computer hardware is either a VMEbased embedded system for hard real-time control, or an ABB S4C+/IRC5 system with an additional PCI-based G4 PowerPC for the Open Robot Control system.

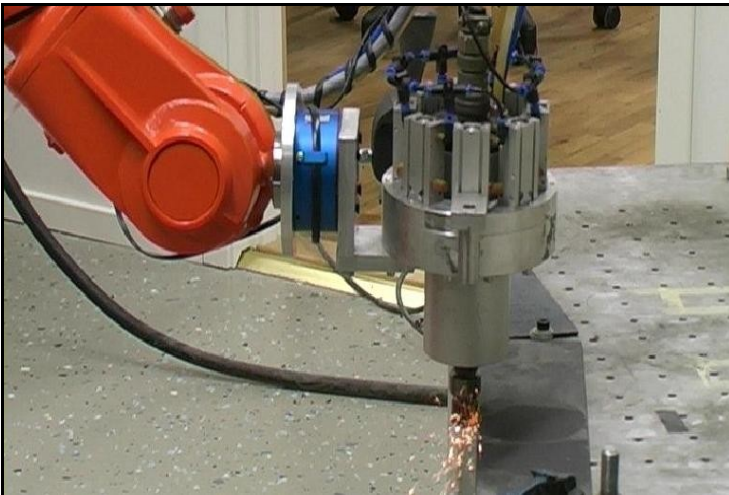

## Productive Robotics @ LTH

*Researchers: Klas Nilsson, Rolf Johansson, Gunnar Bolmsjö and Karl Åström, Mats Alaküla*

### *Research Direction*

Several research interests are represented in Robotics Lab:

- Open Control Software Architectures
- Exteroceptive Robots
- Force Control
- Robot Vision
- Sensor Fusion
- Adaptive and Iterative Learning Control
- Task-level Programming

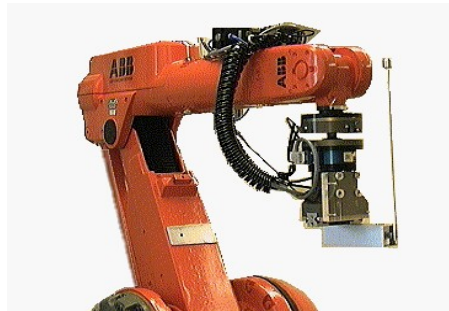

Robot control systems and other manufacturing equipment are traditionally closed. This circumstance has hampered system integration of manipulators, sensors and other equipment. As a result, such system integration has often been made at an unsuitably high hierarchical level.

The purpose of past and present projects is to show how to organize open robot control systems and to verify these ideas by means of experimental verification.

As a part of this research, we have developed several experimental open robot control systems. The systems are built around industrially available robots that have been reconfigured for experimental purposes.

The developed specific robot interfaces and the integration of the robots into a complete system forms a unique environment for testing and development of algorithms for improvement of performance, sensor integration, programming automation and autonomous operation.

## SMErobot™

*Researchers: Isolde Dressler, Rolf Johansson, Anders Robertsson and Anders Blomdell in cooperation with Anders Nilsson, Dept. Computer Science; Karl Åström, Rikard Bertilsson, Fredrik Kahl, Dept. Mathematics, Lund University, and Dr. Torgny Brogårdh, ABB Robotics.*

The project SMErobot is lead by Fraunhofer – Institut für Produktionstechnik und Automatisierung (IPA) and other project partners include GPS Gesellschaft für Produktionssysteme GmbH, Pro-Support B.V., ABB Automated Technologies Robotics, COMAU S.p.A., KUKA Roboter GmbH, Reis Robotics GmbH & Co. Maschinenfabrik, Güdel AG, Casting technology International LTD by Gurantee, Visual Components Oy, Rinas ApS, SMEEIG EESV, Prospektiv Gesellschaft f. Produktionstechnik und Automatisierung (IPA), German Aerospace Center – Institute of Robotics and Mechatronics, University of Coimbra / ADDF, Instituto di Tecnologie Industriali e Automazione, Fraunhofer – Institut f. Systemtechnik und Innovationsforschung (ISI).

SMErobot is an Integrated Project within the 6<sup>th</sup> Framework Programme of the EC to create a new family of SME-suitable robots and to exploit its potentials for competitive SME manufacturing.

### *The Need*

More than 228 000 manufacturing SMEs in the EU are a crucial factor in Europe's competitiveness, wealth creation, quality of life and employment. To enable the EU to become the most competitive region in the world, the Commission has emphasized research efforts aimed at strengthening knowledge-based manufacturing in SMEs as agreed at the Lisbon Summit and as pointed out at MANUFUTURE-2003. However, existing automation technologies have been developed for capital-intensive large-volume manufacturing, resulting in costly and complex systems, which typically cannot be used in an SME context. Therefore, manufacturing SMEs are today caught in an 'automation trap': they must either opt for current and inappropriate automation solutions or compete on the basis of lowest wages. A new paradigm of affordable and flexible

robot automation technology, which meets the requirements of SMEs, is called for.

### *Breakthrough*

This initiative is intended to exploit the potentials of industrial robots, because they constitute the most flexible existing automation technology. The consortium is set to create a radically new type of robot system - a whole family of SME-suitable robots.

### *Objective*

The SMErobot initiative offers an escape out of the automation trap through:

- Technology development of SME robot systems adaptable to varying degrees of automation, at a third of today's automation life-cycle costs;
- New business models creating options for financing and operating robot automation given uncertainties in product volumes and life-times and to varying workforce qualification;
- Empowering the supply chain of robot automation by focusing on the needs and culture of SME manufacturing with regard to planning, operation and maintenance.

### *Partners*

Five major European robot manufacturers have joined forces in SMErobot, in close cooperation with key component manufacturers, five leading research institutes and universities, and consultants for multidisciplinary RTD, dissemination and training efforts.

### *Implementation*

Demonstrations of fully functional prototypes will be set up in different SME manufacturing branches (plastics & rubber, small-batch foundry, metal parts fabrication, etc.), together with SME end users and SME system integrators, partly from the new Member States. Training and education will be conducted at all levels from researcher to end-users.

### *Integration*

SMEs and society benefit from the combined integration of knowledge along the supply chain of robotic automation, from component manufacturers to end users, from multidisciplinary activities to business/finan-

## *Chapter 5. Research*

cing models, and from fundamental technical research when confronted with SME scenarios. Management includes dedicated support for SME integration.

# Automotive Systems

## Complex Embedded Automotive Control Systems (CEmACS)

*Researchers: Brad Schofield, Tore Hägglund and Anders Rantzer in cooperation with DaimlerChrysler AG, University of Glasgow, The Hamilton Institute and SINTEF.*

The overall aim of the CEmACS project is the development of active safety systems for road vehicles. Part of the work deals with the development of controllers for rollover mitigation. Rollover accidents are a common and deadly form of vehicle accident, particularly for certain vehicle classes such as Sports Utility Vehicles (SUV) and light commercial vans, where the centre of gravity can be high. In the case of commercial vehicles, both the mass and the centre of gravity vary depending on the loading conditions. This complicates the task of finding a controller to mitigate rollover.



The aim of the project is to develop controllers capable of preventing rollover under all loading conditions without restricting vehicle performance unnecessarily. This requires the development of advanced methods of state estimation, parameter estimation and control design. Testing of controllers can be done in an advanced vehicle simulation environment as well as in various test vehicles maintained by DaimlerChrysler.

There are several choices of actuators for vehicle dynamics control, including brakes, active steering and active suspension. In this project the focus is on the use of brake systems allowing individual assignment of braking force (so-called EBD systems). A key issue in the development of control algorithms is how to use the available actuators in an optimal way. A technique known as Control Allocation is used to map 'abstract' control commands (such as total forces and moments) onto actuator inputs. This is done by solving a constrained optimization problem in real time.

This project is finished and summarized in the PhD thesis by Brad Schofield.

## Model-Based Road Friction Estimation

*Researchers: Brad Schofield and Tore Hägglund at Lund University, Jacob Svendenius at Haldex, Fredrik Bruzelius and Stefan Solyom at Volvo Cars.*

Road vehicles rely strongly on friction. Their large masses, when moving at high speeds may cause fatal damage if steerability is lost. The forces determining the motion of the vehicle are generated at the tire-road contact patch and are highly dependent on a sometimes abruptly changing friction. A large safety margin is required while driving in conditions of reduced or uncertain friction, but this is often not sufficiently regarded by drivers. Modern vehicle control systems such as antilock brakes and Electronic Stability Programs (ESP) can, to some extent, correct for mistakes made by the driver, but the performance of such systems always depends on the quality of the information available to them.



Many investigations show a correlation between the road condition and the risk of accidents. The output from a road friction estimator might be used by a device that warns the driver about a bad or suddenly altered road condition. Information about friction can also be used to enhance the functionality of control systems within the vehicle or sent to a global infrastructure that receives and transmits information about the roads.

Work on model-based road friction estimation is undertaken within the *Road Friction Estimation* project, RFE II, involving members from SAAB, VTI, Volvo Technologies, Volvo Cars, Lund University, Luleå Technical University and Haldex Brake Products. The project is a part in the national research programme *Intelligent Vehicle Safety Systems* (IVSS). RFE II is a continuation of the original RFE project.

The aim of the RFE II project is to estimate the friction between tire and road surface and to evaluate and optimize the reliability as well as the delay of the estimation. The model-based estimation subproject is aimed at deriving algorithms for on-board estimation of the friction based on measurements from already available sensors in the vehicle. The main focus is on longitudinal tire force excitations, although expansion to lateral excitation is one of the additional aims of RFE II.

Preliminary tests and evaluations have been performed at test-tracks in Hällered and in Arjeplog, Sweden. Results from the project are presented in the PhD thesis by Brad Schofield.

## Diesel HCCI in Multi-cylinder Engines

*Researchers: Maria Karlsson, Anders Widd, and Rolf Johansson in cooperation with Kent Ekholm, Prof. Bengt Johansson, Dr. Per Tunestål, Div. Combustion Engines, Lund University, and Johan Bengtsson, Petter Strandh, Stefan Strömberg, Volvo Powertrain, Inc.*

Homogeneous Charge Compression Ignition (HCCI) is a hybrid of the spark ignition and compression ignition engine concepts. As in an SI engine, a homogeneous fuel-air mixture is created in the inlet system. During the compression stroke the temperature of the mixture increases and reaches the point of autoignition, just as in a CI engine. One challenge with HCCI engines is the need for good timing control of the combustion. Auto ignition of a homogeneous mixture is very sensitive to operating condition. Even small variations of the load can change the timing from too early to too late combustion. Thus, a fast combustion timing control is necessary since it sets the performance limitation of the load control. This project deals with various approaches to feedback control of the



## Chapter 5. Research

HCCI engine for optimized fuel economy and low emissions. A 12-liter Volvo Diesel engine has been successfully converted to HCCI operation with feedback systems based upon feedback of measured cylinder pressure or ion current.

Among control methods successfully applied, linear quadratic Gaussian control and model-predictive control have been implemented and tested.

During spring 2008, work focused on using LQG control to minimize emissions of NO<sub>x</sub> and soot when the engine was operated using direct injection of diesel fuel only. In this operating mode, the distinction between

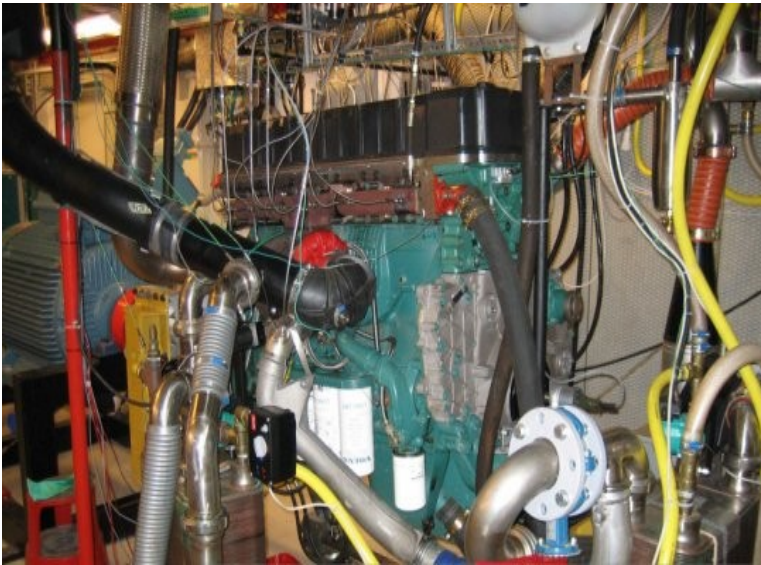

traditional diesel operation and HCCI operation is not sharp. Depending on e.g. fuel injection timings and amount of recycled exhaust gases, the fuel-air mixture at the time of auto-ignition may be more or less homogeneous. The homogeneity of the mixture, and hence the choice of injection timings and amount of recycled exhaust gases, have a large influence on emissions of NO<sub>x</sub> and soot. The work focused on choice of feedback variables and control structure to minimize emissions. It was found that a weighted sum of emissions could be approximated by a quadratic

cost function in the measured variables combustion phasing and ignition delay, to be used as a basis for LQG control.

During fall 2008, model-based control of port-injected HCCI was investigated. A physical model was used to determine a predictive controller for the combustion phasing using the inlet valve closing and the intake temperature as control signals. The control performance was then investigated experimentally in terms of response time, output variance and robustness towards disturbances.

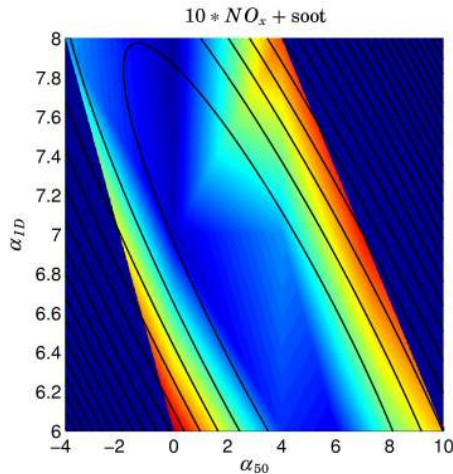

To obtain fast actuation of the intake temperature, the engine was rebuilt so that the intake air was a mixture of a cooled air flow and a flow past an electric heater. The control signals for the temperature control system were two valve positions governing the flow mixture and the heater power. A mid-ranging controller was implemented and yielded a considerable reduction in the response time compared to using only the heater.

This project is financially supported by Volvo Powertrain, Inc., and the Vinnova PFF program (VINNOVA-PFF Ref. 2005-00180).

## KCFP, Closed-Loop Combustion Control

*Researchers: Rolf Johansson and Anders Widd in cooperation with Assoc. Prof. Per Tunestål and Prof. Bengt Johansson, Div. Combustion Engines.*

Competence Center Combustion Processes at Lund University focuses on research of combustion processes between conventional HCCI (Homogeneous Charge Compression Ignition) and classical Otto and Diesel engines.

Project aims:

- System identification of combustion processes under closed-loop control;
- Development of algorithms hardware implementation suitable for ASICs and FPGA;
- Control-oriented modeling and simulation of combustion processes.

In addition to aspects of modeling related to thermodynamics, chemical combustion kinetics, and engine operation, careful attention is required for control-oriented combustion modeling and the interactions among dynamics, control, thermodynamics and chemical combustion properties. Modeling of engine-load transients as well as thermal transients also belong to this important domain of modeling. Progress in this area is important and necessary for successful and robust control such as model-predictive control.

Within the project a cycle-resolved, physics-based, model of HCCI has been developed. The model includes a low-complexity model of the cylinder wall temperature dynamics in order to capture the relevant time-scales of transient HCCI when only small amounts of hot residuals are trapped in the cylinder. The temperature evolution of the gas charge is modeled as isentropic compression and expansion with three heat transfer events during each cycle.

During 2008, work has focused on design and evaluation of model predictive controllers based on linearizations of the model. The considered control signals were the inlet valve closing and the intake temperature. Simulations were used for the initial control design and the resulting controller was tested experimentally. The control performance was evaluated in terms of response time to set-point changes and the resulting output variance.

It was found that a comparable decrease in the output variance in some operating points could be achieved either by introducing a disturbance model or by changing linearization.

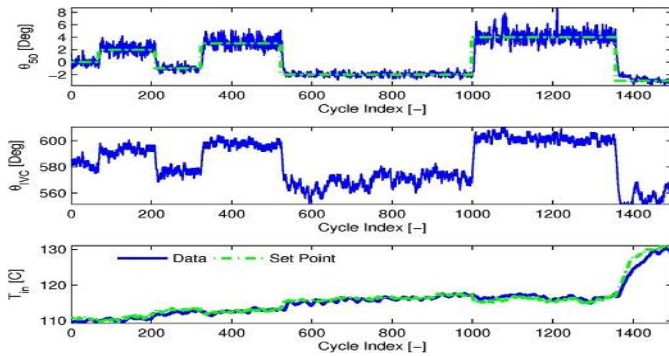

Consecutive set-point changes.

All tested set-point changes were accomplished within 20 engine cycles or less. Only minor changes to the intake temperature were required for moderate changes.

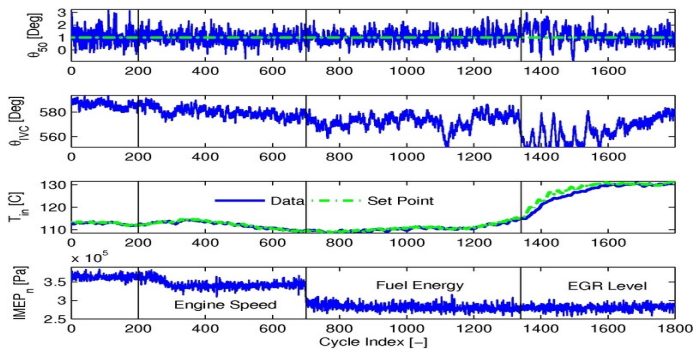

Response to disturbances.

The closed-loop system showed good robustness towards disturbances in engine speed, injected fuel energy, and the amount of recycled exhaust gases.

## Biomedical Projects

### Cardiologic Analysis and Modeling

*Researchers: Rolf Johansson in cooperation with Prof. S. Bertil Olsson, and Dr. Jonas Carlson, Dept. Cardiology, Lund University Hospital, Lund University.*

This project is directed towards chronic atrial fibrillation (CAF), one of the most common cardiac arrhythmias in man and associated with increased morbidity and mortality. Previous studies in animals have shown that experimental atrial fibrillation is based on different types of intraatrial electrical reentry. By exploring the activation of the right atrial free wall during open-heart surgery in patients with CAF and an underlying heart disease, we confirmed the presence of reentry mechanisms. In addition, areas with organized activation were identified. The nature of the organized activation suggested reentry in an anatomical structure, like the right annular bundle surrounding the tricuspid valve. In patients without signs of organized activation, multiple activation waves continuously reenter due to functional properties of the atrial myocardium. An interesting result was that we failed to demonstrate that anisotropy in conduction velocity be a general property of the epicardial right atrial free wall of the intact human heart in patients with stable sinus rhythm as well as in patients with CAF.

### Balance Laboratory

*Researchers: Rolf Johansson in cooperation with Prof Måns Magnusson, Dr. Per-A. Fransson and Dr. Mikael Karlberg (Department of Clinical Sciences, Div. Otorhinolaryngology, Lund University Hospital)*

The project is directed towards assessment of normal and pathological human postural control. System identification and mathematical modeling of the dynamics in postural control are studied with special interest on adaptation, reflexive and anticipatory control. Reflexive and voluntary eye movements are studied in patients with lesions related to balance disorders. Experimental studies, with special reference to the level of alertness, are undertaken to enhance understanding, diagnosis and treatment of dizziness and vertigo. A major complication is that human

postural control is characterized by multisensory feedback control (visual, vestibular, proprioceptive feedback) and this fact is reflected both in experiment design and analysis. Special interest is directed to the importance of cervical and vestibular afferent pathways. To this purpose, stability properties are studied by means of induced perturbations specific to each sensory feedback loop by using system identification methodology. The work is supported by the Scientific Research Council (Grant 2004-4656: Quantification of human postural control, reflexive eye movements and development of therapies for disturbed balance and dizziness) and the Faculty of Medicine, Lund University.

## DIAdvisor™—Personal Glucose Predictive Diabetes Advisor

*Researchers: Rolf Johansson, Mona Landin-Olsson (Lund University Hospital), Per Hagander, Marzia Cescon and Fredrik Ståhl*

*This project is co-funded by the EU through the ICT programme under FP7 (Ref. ICT-216592) European Commission—ICT for Health.*

The DIAdvisor™ is a large-scale integrating project (IP) aiming at the development of a prediction based tool which uses past and easily available information to optimise the therapy of type I and developed type II diabetes. The DIAdvisor™ is not dependent on specific sensor technologies and can be adapted to technologies like standard strip sensing, minimally-invasive continuous glucose sensors and emerging non-invasive methods.

For safety reason, the DIAdvisor™ system will be able to self-assess the confidence of its proposed decisions. For safety reasons as well as for the sake of therapy improvements, the system connects and provides information and trends to the Health Care Provider.

Glucose prediction is difficult and requires advanced science within the fields of physiological modelling, identification theory, control theory, medical device technology, risk management theory, sensor science and user understanding. It can be achieved only by a well balanced group of eminent experts, including academics, clinicians, user representatives and leading companies.

The expected impact of DIAdvisor™ will be improved diabetes control and quality of life in large populations of insulin treated patients, leading to fewer diabetic complications and lower Health Care costs. Moreover, the project will constitute a valuable opportunity for European compan-

## *Chapter 5. Research*

ies to build up a special know-how leading to products that profoundly and positively have an impact on the lives of millions of people with other indications than diabetes.

## Tools

A large number of software tools for analysis, design, and simulation of control systems have been developed at the department since the 1970's. Below we list tools that are being actively developed or maintained at the current time. The tools are free software and can be downloaded from the department web page.

### TrueTime

TrueTime is a Matlab/Simulink-based simulator for real-time control systems. TrueTime facilitates co-simulation of controller task execution in real-time kernels, network transmissions, and continuous plant dynamics.

### Jitterbug

Jitterbug is a Matlab-based toolbox that allows the computation of a quadratic performance criterion for a linear control system under various timing conditions. Using the toolbox, one can easily and quickly assert how sensitive a control system is to delay, jitter, lost samples, etc., without resorting to simulation.

### Grafchart

Grafchart is a toolbox for supervisory level sequence control and procedure handling that has been developed at the department since 1991. Grafchart is based on ideas from Grafcet/Sequential Function Charts, Petri nets, Statecharts, and object-oriented programming.

### MPCtools

MPCtools is a freely available Matlab/Simulink-based toolbox for simulation of MPC controllers. MPCtools provides easy to use functions to create and simulate basic MPC controllers based on linear state space models.



# 6. External Contacts

A healthy mix of fundamental and applied work is a cornerstone of our activities. In the applications projects the goal is to solve real control problems together with external partners. In these projects the problems are approached with an open mind without glancing at particular methods. One purpose is to learn about real problems, another is to learn about new problems that are suitable for theoretical research.

An important role for universities is to organize knowledge in such a way that the results can easily be digested by engineers in industry. There is naturally a strong symbiosis with teaching in this activity. A good mechanism is thus to introduce new research material into existing and new courses. A related form of technology transfer is to write books and monographs and to develop software.

Exchange of personnel between industry and university is another very effective vehicle for technology transfer.

## Industrial Contacts

We have very good working relations with many companies and organizations. The interactions are at different levels and of different intensities, from visits and discussions to joint projects. Master's theses and education are also important ingredients. During the year we have had major projects with

- ABB Automation Technologies/Robotics
- ABB Corporate Research Sweden/Germany/Borealis AB
- ABB Robotics Products, Västerås
- Borealis AB
- Castings Technology International, England
- Ericsson
- Gudel, Switzerland
- KPS Rinas, Denmark

- Novo Nordisk AS
- Perstorp AB
- Pidab AB
- TetraPak
- Toumaz Technology Ltd, Abingdon, UK
- Volvo Powertrain, Inc

## European Collaboration

During 2008 the department was involved in the 6<sup>th</sup> and 7<sup>th</sup> Framework Program of the European Commission.

### *FP6 Projects:*

- ARTIST2 – Embedded Systems Design
- HYCON – Hybrid Control: Taming heterogeneity and complexity of networked embedded systems
- EURON-II – European Robot Research Network
- SMERobot™

### *FP7 Projects:*

- ACTORS
- Aeolus
- ARTIST-DESIGN
- CHAT
- DIAdvisor™

# 7. Dissertations

## PhD Theses

Three PhD theses were defended this year, by Brad Schofield, Peter Alriksson and Andreas Wernrud.

The abstracts are presented below in chronological order. PDF documents of the theses are available at:

<http://www.control.lth.se/publications/>

## Approximate Dynamic Programming with Applications



Andreas Wernrud - PhD dissertation, February 29, 2008.

*Opponent: Prof. Pablo Parrilo, Massachusetts Institute of Technology, USA. Committee: Prof. Karl Henrik Johansson, Kungliga Tekniska Högskolan, Stockholm, Sweden; Prof. Lars Gruene, Universität Bayreuth Mathematical Institute, Germany. Dr. Wolfgang Reinelt, ELAU AG, Marktheidenfeld, Germany.*

This thesis studies approximate optimal control of nonlinear systems. Particular attention is given to global solutions and to the computation of approximately optimal feedback controllers. The solution to an optimal control problem is characterized by the optimal value function. For a large class of problems the optimal value function must satisfy a Hamilton-Jacobi-Bellman type equation. Two common methods for solving such equations are policy iteration and value iteration. Both these methods are studied in this thesis. An approximate policy iteration algorithm is presented for both the continuous and discrete time settings. It is shown that the sequence produced by this algorithm converges monotonically towards the optimal value function. A multivariate polyno-

mial relaxation algorithm is proposed for linearly constrained discrete time optimal control problems with convex cost. Relaxed value iteration is studied for constrained linear systems with convex piecewise linear cost. It is shown how an explicit piecewise linear control law can be computed and how the resulting lookup table can be reduced efficiently. The on-line implementation of receding horizon controllers, even for linear systems, is usually restricted to systems with slow dynamics. One reason for this is that the delay between measurement and actuation introduced by computing the control signal on-line can severely degrade systems with fast dynamics. A method to improve robustness against such delays and other uncertainties is presented. A case study on the control of DC–DC converters is given. Feasibility of a Relaxed Dynamic Programming algorithm is verified by synthesizing controllers for both a step-down converter and a step-up converter. The control performance is evaluated both in simulations and in real experiments.

## Model-Based Vehicle Dynamics Control for Active Safety



Brad Schofield - PhD dissertation, September 19, 2008.

*Opponent: Prof. Tor Arne Johansen, Department of Engineering Cybernetics, Norges teknisk-naturvitenskapelige universitet, NTNU, Trondheim, Norge.*

*Committee: Prof. Carlos Canudas de Witt, Département d'Automatique de Grenoble, GIPSA-lab, INRIA-CNRS, Saint-Martin-d'Hères, France; Prof. Fredrik Gustafsson, Div. Of Automatic Control, Dep. Of Electrical Engineering, Linköping University, Linköping, Sweden; Dr. Per Persson, Volvo Personvagnar AB, Gothenburg, Sweden.*

The functionality of modern automotive vehicles is becoming increasingly dependent on control systems. Active safety is an area in which control systems play a pivotal role. Currently, rule-based control algorithms are widespread throughout the automotive industry. In order to improve performance and reduce development time, model-based methods may be employed. The primary contribution of this thesis is the development of a vehicle dynamics controller for rollover mitigation. A central part of this work has been the investigation of control allocation methods, which are used to transform high-level controller commands to actuator inputs in

the presence of numerous constraints. Quadratic programming is used to solve a static optimization problem in each sample. An investigation of the numerical methods used to solve such problems was carried out, leading to the development of a modified active set algorithm. Vehicle dynamics control systems typically require input from a number of supporting systems, including observers and estimation algorithms. A key parameter for virtually all VDC systems is the friction coefficient. Model-based friction estimation based on the physically-derived brush model is investigated.

## State Estimation for Distributed and Hybrid Systems



Peter Alriksson - PhD dissertation, September 26, 2008.

*Opponent: Prof. Raffaello D'Andrea, Department of Mechanical and Process Engineering, ETH, Zürich, Switzerland. Committee: Prof. Lennart Ljung, Reglerteknik, Linköping University, Linköping, Sweden; Prof. Jonas Sjöberg, Dept. of Mechatronics, Chalmers, Göteborg, Sweden; Docent Jan Sternby, Treatment Systems Research, Gambro AB, Lund, Sweden.*

This thesis deals with two aspects of recursive state estimation: distributed estimation and estimation for hybrid systems. In the first part, an approximate distributed Kalman filter is developed. Nodes update their state estimates by linearly combining local measurements and estimates from their neighbors. This scheme allows nodes to save energy, thus prolonging their lifetime, compared to centralized information processing. The algorithm is evaluated experimentally as part of an ultrasound based positioning system. The first part also contains an example of a sensor-actuator network, where a mobile robot navigates using both local sensors and information from a sensor network. This system was implemented using a componentbased framework. The second part develops, a recursive joint maximum a posteriori state estimation scheme for Markov jump linear systems. The estimation problem is reformulated as dynamic programming and then approximated using so called relaxed dynamic programming. This allows the otherwise exponential complexity to be kept at manageable levels. Approximate dynamic programming is also used to develop a sensor scheduling algorithm for linear systems.

The algorithm produces an offline schedule that when used together with a Kalman filter minimizes the estimation error covariance.

## Licentiate Theses

Two licentiate theses were also defended during 2008, by Maria Karlsson and Toivo Henningson.

The abstracts are presented below in chronological order. PDF documents of the theses are available at:

<http://www.control.lth.se/publications/>

### Control Structures for Low-Emission Combustion in Multi-Cylinder Engines



Maria Karlsson – Licentiate dissertation, March 28, 2008.

*Opponent: Prof. Luigi del Re, Institute of Design and Control of Mechatronical Systems, Johannes Kepler University, Linz, Austria.*

Traditionally, heavy-duty diesel engines have high efficiencies but also high emissions of NO<sub>x</sub> and soot particles. New engine concepts show the potential to retain diesel-like efficiencies while reducing emissions by forming a completely or partially homogeneous mixture of fuel and air prior to ignition through compression. The long ignition delay required to form this homogeneous mixture makes the combustion process less predictable and inherently more difficult to control. This thesis summarizes work on control structures for three different setups of such low-emissions combustion engines. In a port-fuel injection engine, it was shown that combining two control variables in a mid-ranging control structure can address the problem of actuator saturation. In a fumigation engine, control was proven to be a powerful tool for automatic calibration in a laboratory setting. In a direct injection engine, LQG controllers were designed to optimize an emissions trade-off cost function during transients. Experiments were performed on a six-cylinder heavy-duty engine, and multi-cylinder effects and complications were explicitly considered in the work.

## Event-Based Control and Estimation with Stochastic Disturbances



Toivo Henningson – Licentiate dissertation, November 28, 2008.

*Opponent: Ass. Prof. Mikael Johansson, Automatic Control, School of Electrical Engineering, KTH, Stockholm, Sweden.*

This thesis deals with event-based control and estimation strategies, motivated by certain bottlenecks in the control loop. Two kinds of implementation constraints are considered: closing one or several control loops over a data network, and sensors that report measurements only as intervals (e.g. with quantization). The proposed strategies depend critically on *events*, when a data packet is sent or when a change in the measurement signal is received. The value of events is that they communicate new information about stochastic process disturbances. A data network in the control loop imposes constraints on the event timing, modelled as a minimum time between packets. A thresholdbased control strategy is suggested and shown to be optimal for firstorder systems with impulse control. Different ways to find the optimal threshold are investigated for single and multiple control loops sharing one network. The major gain compared to linear time invariant (LTI) control is with a single loop a greatly reduced communication rate, which with multiple loops can be traded for a similarly reduced regulation error. With the bottleneck that sensors report only intervals, both the theoretical and practical control problems become more complex. We focus on the estimation problem, where the optimal solution is known but untractable. Two simplifications are explored to find a realistic state estimator: reformulation to a mixed stochastic/worst case scenario and joint maximum a posteriori estimation. The latter approach is simplified and evaluated experimentally on a moving cart with quantized position measurements controlled by a low-end microcontroller. The examples considered demonstrate that event-based control considerably outperforms LTI control, when the bottleneck addressed is a genuine performance constraint on the latter.

## 8. Honors and Awards

### *Ather Gattami*

received a scholarship from Hans Werthén Foundation for a two-year post.doc at Massachusetts Institute of Technology, Cambridge, MA, USA. He was also appointed Assistant Professor at KTH, Sweden, supported by the Swedish Research Council.

### *Per Hagander and Staffan Haugwitz*

received, together with Tommy Norén, *the IFAC CEP Best Paper Award* for the paper: “Modeling and control of a novel heat exchange reactor, the Open Plate Reactor”, by S. Haugwitz, P. Hagander and T. Norén, (published in Volume 15, Issue 7 of Control Engineering Practice) at the IFAC World Congress in Seoul on July 8, 2008.

### *Rolf Johansson and Anders Robertsson*

received *Euron/EUnited Robotics Technology Transfer Award 2007, Third Prize* (shared with a research group of members from Lund University, Linköping University, ABB Robotics and Saab Aircraft—Tomas Olsson, Mathias Haage, Henrik Kihlman, Torgny Brogårdh, Klas Nilsson, Anders Robertsson, Robert Isaksson, Gilbert Ossbahr, Mats Björkman, Magnus Engström, Rolf Johansson) for “Cost-effective Drilling using Industrial Robot with High-bandwidth Force Feedback”.

### *Anders Rantzer*

received the IET Premium award for the best article in IEE Proceedings - Control Theory & Applications 2006.

### *Eva Schildt*

received *Peter Honeth’s Administrativa pris* (Best Price Award for Performing Excellent Administrative Work) 2008.

### *Björn Wittenmark*

was appointed *Life Member of IEEE*.



## 9. Personnel and Visitors



### Personnel

During 2008 the following persons have been employed at the department. The list shows the status of December 2008 if nothing else is mentioned.

#### Professors

Karl-Erik Årzén  
Karl Johan Åström

Bo Bernhardsson (part time)  
Per Hagander  
Tore Hägglund  
Rolf Johansson  
Anders Rantzer  
Björn Wittenmark

## Associate Professors

Anton Cervin  
Charlotta Johnsson  
Anders Robertsson

## Assistant Professor

Johan Åkesson

## Research Engineers

Leif Andersson  
Anders Blomdell  
Rolf Braun

## Post Doctors

Ather Gattami (until March)  
Kin Cheong Sou (from October)

## PhD Students

Martin A. Kjaer  
Peter Alriksson (until September)  
Marzia Cescon (from July)  
Isolde Dressler  
Olof Garpinger  
Pontus Giselsson  
Erik Johannesson  
Maria Karlsson  
Per-Ola Larsson  
Mikael Lindberg

## *Chapter 9. Personnel and Visitors*

Magnus Linderoth (from September)  
Daria Madjidian (from August)  
Karl Mårtensson  
Oskar Nilsson  
Toivo Perby Henningsson  
Philip Reuterswård (from January)  
Vanessa Romero Segovia (from August)  
Brad Schofield (until August)  
Kristian Soltesz (from October)  
Aivar Sootla  
Fredrik Ståhl (from May)  
Andreas Wernrud (until June)  
Anders Widd

## **Scholarships**

Aleks Ponjavic, Vinnova Rz (August-September)

## **Administrators**

Britt-Marie Mårtensson  
Eva Schildt  
Agneta Tuszyński (until December)  
Eva Westin (from November)

## **Visitors**

### **Visiting Scientists**

The following researchers have stayed with the department for some shorter or longer period of time.

Angel Cuenta Lacruz, Technical University of Valencia, Spain (June)  
Pedro Garcia, Technical University of Valencia, Spain (June-July)  
Georgios Kotsalis, SIG2 project (until January)  
Cedric Langbort (University of Illinois, Urbana, USA (August)  
Giulio Mancuso, Italy (from November)  
José Vasconcelos, Institute for Systems and Robotics, Lisbon, Portugal (August-September)

## Visiting Students

The following foreign students from the ERASMUS program have stayed with us at the department working on their master's theses.

Tommaso Bresciani, Politecnico di Milano, Italy (until October)

Marzia Cescon, Italy (until April)

Johannes Schiffer Germany. (from October)

# 10. Staff Activities

This is a short description of the staff (listed in alphabetical order) and their activities during the year. Publications and lectures are listed in separate sections (chapter 11 and 13 respectively).

## *Åkesson, Johan*

Assistant Professor, PhD (2007); joined the department in 2001. Johan's main research interest is in the field of languages and tools for dynamic optimization of large scale systems, including language design, compiler design and implementation, numerical algorithms, and industrial applications. He is currently leading the JModelica project aimed at developing a Modelica-based open source platform for optimization of dynamic systems. Within the PicLu research project, he is leading the subproject dealing with grade change optimization in cooperation with the plastics manufacturer Borealis. During 2008, he supervised two master's thesis projects: "Modeling and Control of a Reaction Calorimeter" (David Lam and Linda Törner) and "Model Predictive Control Based Energy Management Algorithm for a Hybrid Excavator" (Patrik Thuring). Johan is also associated with Modelon AB, where he works part time.

## *Alriksson, Peter*

MSc, graduate student since 2003. His research interests are in estimation of hybrid- and distributed systems, with special focus on sensor networks. Peter defended his PhD thesis, "State Estimation for Distributed and Hybrid Systems", in September 2008.

## *Andersson, Leif*

MSc, Research Engineer since 1970. Leif started at the department with a responsibility for the teaching laboratory. He designed some lab equipment, notably an analog computer. In 1976 he started in earnest with digital computers, and has been responsible for the department computing facilities since then. The main computer systems have been RT11, VAX/VMS, Sun Solaris, Linux and lately MacOSX. He has also been forced to handle Microsoft Windows. His professional activities, apart

from computer system maintenance, have ranged from computer typesetting (TeX and LaTeX) via Real Time Programming to using Java as a tool for writing educational software.

*Årzén, Karl-Erik*

Professor (2000), PhD (1987). Joined the department in 1981. His research interests are real-time and embedded control, real-time systems, programming languages for control, Petri nets and Grafacet, and monitoring and diagnosis. Leader for the cluster on control for embedded systems within the EU/IST FP6 network of excellence ARTIST2 on design of embedded systems. Leader of the Design for Adaptivity activity in the EU/IST FP7 network of excellence ArtostDesign. During the year he has primarily been involved in the EU/IST FP7 STREP project ACTORS (Adaptivity and Control of Resources in Embedded Systems). He has been responsible for and taught the undergraduate courses Real-Time Systems, International Project Course in Automatic Control and the Project Course in Automatic Control. He is partly or fully involved in the supervision of three PhD students.

*Åström, Karl Johan*

Professor in Automatic Control since 1965, founder of the department, emeritus from 2000. This year he has worked on event based control, friction modeling and control of microsystems. He gave a new graduate course on Control of Microsystems at UCSB. In May he visited Prof Gerd Jaeger's group at the Institute of Process Measurement and Sensor Technology in Ilmenau to work on friction modeling. He participated in the ARTIST2 summer school. He has given many invited lectures to academic and industrial audiences during the year.

*Bernhardsson, Bo*

PhD 1992, Professor 1999, on leave for industry work since 2001. In 2008 he worked 20% at the Department and 80% at Ericsson Mobile Platforms in Lund. Bo's research interests are in linear systems, practical applications of control theory, and the connection between communication and control theory.

*Blomdell, Anders*

Research Engineer at the department since 1988. Heavily involved in almost all aspects of Robotics Research at the department, also responsible for the department network and lab computers for teaching and research.

## Chapter 10. Staff Activities

Awarded “Chief Kernel Hacker” award at his L<sup>TH</sup> birthday. Works with extending and refining the Open Robot Control Architecture (ORCA) used in the robotics lab.



### *Braun, Rolf*

Research Engineer at the department since 1969. Designs and builds equipment for education and research, and handles hardware maintenance of computers and equipment. He also plans and supervises maintenance and rebuilding of offices and labs.

### *Cervin, Anton*

Associate professor, PhD (2003); joined the department in 1998. Anton's research interests include real-time systems, networked control, event-based control, and computer tools for analysis and simulation of controller timing. During 2008, he has worked in his research project “Periodic and event-based control over networks”, funded by the Swedish Research Council. He is the advisor of PhD student Toivo Henningsson, who presented his licentiate thesis on event-based control in November. He has also been involved in various activities within the ARTIST2 Network of Excellence on Embedded Systems Design, including lecturing at the Graduate Course on Embedded Control Systems. As Chairman of SNART, he was co-organizer of the Swedish Embedded Systems Meeting in March. During the year, he has also been a lecturer in the basic-level course Systems Engineering and the advanced-level course Real-Time Systems. Since June 2008, he is coordinator of the China Profile at LTH.

### *Cescon, Marzia*

BSc, MSc, graduate student since July 2008. Main research interests involve subspace-based identification techniques with application to biomedical systems. Currently working on the DIAdvisor project within the European FP7-ICT program, pursuing research on prediction and predict-

ive control of blood glucose concentration in diabetic subjects. Her teaching activities during the fall were related to the Basic Course in Automatic Control and the Predictive Control Course.

*Dressler, Isolde*

MSc, graduate student since September 2004. Isolde is interested in modeling, calibration and control of parallel kinematic robots and works within the SMERobot project. She was teaching assistant in the System Identification and the Automatic Control Basic Course.

*Garpinger, Olof*

MSc, graduate student since August 2005. Olof is involved in the project “Decentralized Structures for Industrial Control”, which is funded by The Swedish Research Council (VR). The research concerns automatic tuning of processes with two inputs and two outputs (TITO systems). Besides this, Olof has developed a new Matlab based software for design of IAE optimal PID controllers with robustness constraints. The software has been used to derive PI and PID controllers for real plants, with the hope to make the D-part more accepted in industry. The idea is to let the user set a limit on the maximum allowed control signal variance due to measurement noise. During 2008, Olof has also been teaching assistant in the Multivariable Control course as well as in the Basic Control course.

*Gattami, Ather*

PhD, MSc, Researcher July 2007 - February 2008. Ather Gattami’s interests include optimization and optimal control, decision theory, game theory, information theory with applications to decisions with information constraints. Ather has been teaching in various courses at the department such as “Automatic Control”, “Nonlinear Control”, “Adaptive Control”, and “Mathematical Modeling”. Ather has also been supervising a Master’s Thesis project. Activities outside the department include reviewing for international journals and conferences, and participations in international workshops and conferences.

*Giselsson, Pontus*

MSc, graduate student since November 2006. So far Pontus has spent most of his time on courses. He has also been a teaching assistant in two basic courses, Automatic Control and Systems Engineering, and in one advance course, Nonlinear Control and Servo Systems. Pontus has also



created a new laboratory exercise that is used in the course Nonlinear Control and Servo Systems.

*Hagander, Per*

Professor, PhD (1973). Per has been with the department since 1968 and works with linear system theory and with applications in biotechnology and medicine. He acted as Conferrer of Doctor's Degrees for the Faculty of Engineering, LTH, 2008-05-30. During 2008 he taught the basic course together with the course Control Theory. He has lead a project on the control of a special type of continuous chemical reactors together with Alfa Laval AB, partially funded by EU-FP6 HYCON, WP4b. He also participates in the EU-FP6 project DIAdvisor.

*Henningsson, Toivo Perby*

LicSc, graduate student since August 2005. His research interests are in event based, distributed and embedded control and estimation. Toivo is working on event based control for information constrained systems. During 2008 he presented his Licentiate thesis titled "Event-Based Control and Estimation with Stochastic Disturbances", and was a teaching assistant in the Project Course and the Real-Time Systems course.

*Hägglund, Tore*

Professor, PhD (1984). Has been at the department since 1978 except for four years when he worked for ABB. He is responsible for two of the basic courses in Automatic Control in the engineering program. His main research interests include process control, PID control, adaptive control, control loop monitoring and diagnosis. Main research activities during the year have been design of PID controllers and decentralized control structures. He has also initiated projects on static gain estimation and valve stiction diagnosis. Tore Hägglund is also involved in the establishment of the new Process Industrial Centre at Lund University, PIC-LU.

*Johansson, Rolf*

Professor, MD, PhD. Active at the department since 1979. Rolf Johansson's research interests are in system identification, robotics and nonlinear systems and automotive control. He is node leader for the research projects DIAdvisor, SMERobot, HYCON, SSF ProViking FlexAA, Vinnova PFF Diesel HCCI. He is coordinating director for Robotics Laboratory with cooperation partners from Dept Computer Science, Dept Mechanical Engineering, Dept. Mathematics and industrial partners. He has indus-

trial cooperation with ABB Robotics, Volvo Powertrain, Volvo Car Corporation and Scania CV AB. He is responsible for the two courses FRT041 System Identification and FRTN15 Predictive Control. Together with Dr. Måns Magnusson he leads research at the Vestibular Laboratory, Department of Otorhinolaryngology, Lund University Hospital.

### *Johannesson, Erik*

MSc in Engineering Mathematics. PhD student since May 2006. His research interests are in control and estimation problems in contexts where communication is limited, as well as in event-based control. During the spring, Erik was a teaching assistant for the course in Multivariable control, as well as in the Project course. During the fall, Erik was a guest researcher at the University of Maryland where he worked with Dr. Nuno Martins.

### *Johnsson, Charlotta*

Associate Professor, PhD (1999). Charlotta has been at the department since 1993 except for 4 years (2000-2004) when she worked for Siemens. Charlotta's main research interest is in Production Control, Batch Control Systems, Manufacturing Operations System. Charlotta is one of the principal investigators of the LCCC research program. She is also part of the management team for the research center PicLu in which she is leading one of the sub-projects. During the year, Charlotta has been involved in a variety of courses stretching from technical courses for master and/or Ph.D students to pedagogical courses for teachers in higher education. In addition, Charlotta acted as supervisor and/or examiner for nine (9) master theses. The projects were done in cooperation with industry or international universities. During the year, Charlotta has partly been on maternity leave with her third child.

### *Karlsson, Maria*

LicSc, graduate student since August 2005. She is working with Professor Rolf Johansson in the project Diesel-HCCI in Multi-cylinder Engines in cooperation with Volvo Powertrain and the division of combustion engines at Lund University. During 2008 she completed her licentiate thesis, which was presented in March. From May until December she was on maternity leave with her son Arthur.

*Kjær, Martin Ansbjerg*

MSc, LicSc, graduate student since August 2003. He is working in the field of active control of web servers together with Anders Robertsson. During the last year he has been focusing on experimental work. His teaching activities were related to being a teaching assistant in the advanced topic of Nonlinear Control of Servo Systems.

*Larsson, Per-Ola*

MSc in Electrical Engineering (2005), graduate student since January 2006. His research interest is within process control, especially in processes with delay dominant properties. Per-Ola is involved in a project together with Professor Tore Hägglund concerning tuning methods for a dead-time compensating PID controller. Per-Ola has been involved in teaching the Multivariable Control course, where he also constructed a laboratory sized overhead crane and developed a laboratory exercise that was used in the course.

*Lindberg, Mikael*

MSc, graduate student since July 2007. Main research interests lie in resource management and control for embedded systems using feedback scheduling and reservation based scheduling techniques. Currently participating in the ACTORS-project, a EU sponsored project run by Ericsson Mobile Platform (EMP), and in the “Feedback Based Resource Management and Code Generation for Soft Real-Time Systems”, a VINNOVA sponsored project also in co-operation with EMP. During the fall, Mikael was a teaching assistant in the course Realtime Systems.

*Linderoth, Magnus*

MSc, graduate student since September 2008. He has spent most of his time on courses and continuing the work on his old Master's thesis project, a dart catching robot. He has also been a teaching assistant in the basic course in Automatic Control for undergraduate students.

*Madjidian, Daria*

MSc in Electrical Engineering. I started as a PhD student at the department of Automatic control in August, 2008. During fall of 2008 I tutored a course in Process Control as well as the basic course in Automatic Control.

*Mårtensson, Britt-Marie*

Secretary at the department since 1974. She is responsible for the department library, orders books and handles the mail and office supplies. Assistant Webmaster. She also handles the contact with printing offices for dissertations and other publications. Britt-Marie is also the department's service person.

*Mårtensson, Karl*

MSc, graduate student since December 2006. Karl's research concerns Distributed Control. In this area, he is working with Professor Anders Rantzer. He is currently part of the CHAT project. He has also worked with Model Predictive Control, especially dealing with computational delays. Karl has been involved in teaching the basic course in Automatic Control, as well as in some more advanced courses, e.g. Control Theory.

*Nilsson, Oskar*

LicSc, graduate student since September 2003. Oskar is working together with Anders Rantzer in a project funded by Toyota Motor Corporation. His research is currently focused on model reduction of nonlinear automotive models and nonlinear system identification. During the year of 2008, five weeks were spent at Department of Systems Engineering and Control, Universidad Politécnica de Valencia, Spain.

*Rantzer, Anders*

Professor of Automatic Control since 1999 and head of department. He has broad interests in modeling, analysis and synthesis of control systems, with particular attention to robustness, optimization and distributed control. Anders Rantzer is the main supervisor for several PhD students. During 2008, he taught the courses “FRTN10 Multivariable Control”, “FRT095 Mathematical Modelling”. A PhD course on Distributed Control was given both in Lund and in Willingen, Germany. He also served on several international scientific committees.

*Reuterswärd, Philip*

MSc, Dipl.-math. techn. Graduate student since January 2008. During the year he has been involved in the EUROSYSLIB project, developing a modeling library for network simulations based on TrueTime for the Modelica language. He has also been teaching assistant in the basic course in Automatic Control.

*Robertsson, Anders*

Associate professor (2007), Docent (2005), Research Associate (May 2003), PhD (1999). His main interest is in nonlinear control and robotics. Currently he is working on parallel kinematic robots, sensor-data integration and force control of industrial robots in collaboration with ABB Robotics. The research has been conducted with the LUCAS project, the Robotics Lab and the EU FP6-project SMERobot. He has also been doing research on admission control in network nodes and control of server systems in cooperation with the Department of Electrical and Information Technology, LTH. He has lectured in the basic course on Automatic Control, in Multivariable Control and in the course on Nonlinear Control and Servo Systems, and acted as advisor/co-advisor for 3 PhD students and several Master's Thesis projects.

*Romero Segovia, Vanessa*

Born in Peru, she is a MSc graduate student since August 2008. Vanessa is interested in real-time systems and embedded control and is currently working for the ACTORS project. During the autumn she was a teaching assistant in the Real-Time Systems course.

*Schildt, Eva*

Secretary at the department since 1970. Eva is mainly responsible for the financial transactions of the department such as bookkeeping and reporting to our sponsors. She handles the personnel administration and takes care of the administration concerning visitors at the department. She was absolutely surprised but also delighted to receive "Peter Honeth's Administrativa pris" 2008.

*Schofield, Brad*

PhD. September 2008, graduate student since August 2003. Brad's research interests include vehicle dynamics control, in particular for active safety systems. Between 2004 and 2007 Brad was involved with the EU 6th framework project Complex Embedded Automotive Control Systems (CEmACS) which dealt with the development of active safety systems for road vehicles. Brad's work on the project involved the design of control systems for the prevention of vehicle rollover accidents. In late 2007 Brad began work on the Intelligent Vehicle Safety Systems (IVSS) Road Friction Estimation (RFE) II project, which involves tire modelling and the development of estimation algorithms for friction estimation in passenger cars and trucks. Brad has been a teaching assistant in the System

Identification and Predictive Control courses. He is currently working at Modelon AB in Gothenburg, Sweden.

*Soltesz, Kristian*

MSc, graduate student since October 2008. During the first few months Kristian has spent most of his time attending PhD courses and being a teaching assistant in the Automatic Control basic course. He has also been involved in lab process development at the department.

*Sootla, Aivar*

MSc, graduate student since autumn 2006. Aivar's main research interests are model simplification, validation and reduction. He was a teaching assistant in basic Automatic Control course for undergraduate students.

*Sou, Kin Cheong*

PhD (2008). Postdoc since Oct 2008. His research interests include optimization with applications to engineering problems with main focus on system theory and model reduction for dynamical systems. In 2008, he was responsible for giving the PhD course "Convex Optimization with Applications".

*Ståhl, Fredrik*

MSc (2003), 50 % graduate student since 2008. Fredrik is involved in the DIAdvisor project, where his research has focused on modeling, identification and prediction of blood glucose dynamics. Together with Prof. Rolf Johansson he has written the journal paper "Diabetes Mellitus modeling and short-term prediction based on blood glucose measurements" published in *Mathematical Biosciences* 217 2009 (pp. 101-117).

*Tuszynski, Agneta*

Retired in December after having worked as a secretary at the department since 1981. She was responsible for registration of the student's and PhD student's course entries and exam results. Also working with word processing in LATEX.

*Wernrud, Andreas*

Andreas defended his Doctorate Thesis in June. He is now working for FOI (Swedish Defence Research Agency) in Linköping.

*Westin, Eva*

Administrator at the department since November 2008. She has the overall responsibility for the registration of students and PhD students as well as for their exam results. She updates parts of the department's web site. Eva is also working with administration of the LCCC Linnaeus Project and visitors at the department. Together with Tore Hägglund she is responsible for the Activity Report 2008.

*Widd, Anders*

MSc, graduate student since December 2006. He is working with Professor Rolf Johansson on the project "KCFP, Closed-Loop Combustion Control", which is a cooperation with the Division of Combustion Engines. He has also participated in the project "Diesel-HCCI in a Multicylinder Engine". During 2008 he has worked on model predictive control of HCCI engines using physics-based models. He has been a teaching assistant in the predictive control course and the international project course.

*Wittenmark, Björn*

Professor in Automatic Control since 1989. He joined the department in 1966 and took his PhD in 1973. His main research interests are adaptive control, sampled-data systems, and process control. He is currently working within projects in the area of process design and control and control of communication networks. Between March 1, 2003 and December 31, 2008 he was Assistant vice-chancellor (Vice president) of Lund University. During 2008 he was initiating and supervising the Research Quality Assurance for the Future (RQ 8). RQ 8 is a peer review of the research at Lund University.

## External Assignments

### Opponent and Member of Examination Committee

#### *Årzén, Karl-Erik*

Deputy member of the PhD thesis committee for Eligijus Kubilinskas, March 18, Department of Communication Systems, Lund University. Member of the PhD thesis committee for Calle Lejdfors, June 13, Department of Computer Science, Lund University. Opponent for the PhD thesis of Lasse Eriksson, November 28, Department of Automation and Systems Technology, Helsinki University of Technology, Finland. Deputy member of the PhD thesis committee for Richard Johansson, December 5, Department of Computer Science, Lund University.

#### *Hägglund, Tore*

Member of the Examination Committee for the PhD thesis by Christer Karlsson, August 19 at Mälardalen University, Västerås, Sweden.

#### *Rantzer, Anders*

Member of PhD thesis committee for Daniel Axehill Feb 27, at Linköping University. Member of PhD thesis committee for Johan Nilsson, Dec 6 at Lund University. Member of PhD thesis committee for Johan Karlsson, Oct 31 at Royal Institute of Technology (KTH).

#### *Robertsson, Anders*

Faculty Opponent for doctoral thesis (Peter Naucér, “Estimation and Control of Resonant Systems with Stochastic Disturbances” Uppsala May 23, 2008). Member of PhD-thesis committee (Svetlana Bizjajeva, “Sequential Monte Carlo Methods with Applications in Positioning and Tracking in Wireless Networks”, Lund, Oct 3, 2008).



## Board Member

### *Årzén, Karl-Erik*

Member of the Research Senate, Lund University. Member of the Strategic Management Board of the Artist2 Network of Excellence. Member of the Strategic Management Board of the ArtistDesign Network of Excellence.

### *Cervin, Anton*

Board Member and Chairman of SNART (the Swedish National Real-Time Association).

### *Hagander, Per*

Chairman of the Faculty Representatives at the Faculty of Engineering, LTH, Lund University.

### *Hägglund, Tore*

Member of the evaluation committee on Signals and Systems at the Swedish Research Council. Expert member in legal proceedings for patent at Svea Court of Appeal, 2007–2009.

### *Johansson, Rolf*

Member of SMERobot Scientific and Technical Advisory Board. Member of DIAdvisor Executive Board.

### *Johnsson, Charlotta*

Board member of WBF (the Forum for Automation and Manufacturing Professionals) where she serves as the Treasurer (ending June 2008) and the Director of European Operations. Board member in Technology Management Center (TMC) at Lund University.

### *Rantzer, Anders*

Member of the steering committee for the International Symposium on Mathematical Theory of Networks and Systems.

### *Robertsson, Anders*

Deputy member of “Läraryörelsen” at the Faculty of engineering, Lund University.

*Wittenmark, Björn*

Assistant vice-chancellor (Vice president) for Lund University from March 1, 2003 until December 31, 2008. Chairman Lund Laser Center. Board member of LUCAS, PIC-LU and EASE. Board member Gyllenstiernska Krapperupsstiftelsen. Member of the Technical Committee for IFAC Adaptive Control and Learning.

## Book and Journal Editor

*Hägglund, Tore*

Editor for Control Engineering Practice.

*Johansson, Rolf*

Associate Editor, Int. J. Adaptive Control and Signal Processing. Associate Editor, *Chinese Journal of Scientific Instrument*, (China Instrument and Control Society).

*Wittenmark, Björn*

Member of Editorial Board: Journal of Forecasting and IEE Proceedings Control Theory & Applications.

## Advisory Committees and Working Groups

*Hagander, Per*

Member of IFAC Technical Committee BIOMED. Member of IFAC Technical Committee Biotechnological Processes. Member of ESBES--Working group M<sup>3</sup>C.

*Johansson, Rolf*

Science Foundation Ireland (SFI), Research Frontiers Programme, February 28-29, 2008, Dublin, Ireland. Board Member of DIAdvisor Executive Board. Member of IEEE EMBS Technical Committee (TC) for Biomedical Robotics. Member of Joint EMBS/RAS Advisory Committee on Biorobotics. Reviewer Seventh EU Framework Programme (FP7), Information and Communication Technologies (ICT-2007). Reviewer Seventh EU Framework Programme (FP7), Nanosciences, Nanotechnologies, Materials and New Production Technologies (NMP-2008). Reviewer, Nor-

way Research Council, Information and Communication Technology (ICT) Program, November 2008.

*Johnsson, Charlotta*

Voting member in the standardisation committee ISA 95. Information member in the standardisation committees ISA 88 and ISA 99. Member in SEK and serves as the Swedish expert in the international IEC and ISO working group JWG5.

*Rantzer, Anders*

Member of the Advisory Board for Lecture Notes in Control and Information Sciences at Springer Verlag Heidelberg. Member of the IEEE Control System Society Technical Committee on Nonlinear Systems and Control. Member of the IFAC Technical Committee on Nonlinear Systems.4 Member of the Swedish IFAC Committee. Expert evaluator for VINNOVA.

*Wittenmark, Björn*

Reviewer for research evaluations for the Australian Research Council, Italian Ministry for Education University and Research (MIUR) and Norwegian Research Council.

## Member of International Program Committee (IPC)

*Årzén, Karl-Erik*

Member of the IPC for the Modelica 2008 Conference, Bielefeld, Germany, March 2008. Member of the IPC for the 11th International Conference on Hybrid Systems: Computation and Control (HSCC'08), St Louis, US, April 2008. Member of the IPC for the Third IEEE International Workshop on Feedback Control Implementation and Design in Computing Systems and Networks (FeBID), Annapolis, US, June 2008. Member of the IPC for the 20th European Conference on Real-Time Systems (ECRTS), Prague, Czech Rep., July 2008. Member of the IPC for the International Workshop on Real-Time Software, Wisla, Poland, October 2008.

*Cervin, Anton*

Member of the Program Committee of the Workshop on Adaptive and Reconfigurable Embedded Systems (APRES'08). Member of the Program Committee of the Real-Time and Networked Embedded Systems Track of the 13th IEEE International Conference on Emerging Technologies and Factory Automation (ETF'A'08).

*Hagander, Per*

Member of IPC for the 7th IFAC Symposium on Modelling and Control in Biomedical Systems.

*Hägglund, Tore*

Member of the International Program Committees for the conferences Control'08 - 8th Portuguese Conference on Automatic Control in Vila Real, Portugal, Adconip 2008 - International Symposium on Advanced Control of Industrial Processes, Jasper, Canada. 2009 IEEE International Conference on Control Applications, Saint Petersburg, RUSSIA, and the IFAC Symposium on Advances in Control Education, ACE 2009, Kumamoto, Japan.

*Johansson, Rolf*

IPC Member of the International Conference Control 2008, Manchester, Britain, 2008. IPC Member of the 8th Portuguese Conference on Automatic Control CONTROL'08, Universidade de Trás-os-Montes e Alto Douro, Vila Real, Portugal, July 21-23, 2008. IPC Member of the 15th Int. Conference on Automatic Control (Automatics 2008), Odessa, Ukraine, September 23-26, 2008. Associate Editor (Invited Papers), 47th IEEE Conference on Decision and Control (CDC08), Cancun, Mexico, December 2008. Editor for Modeling, 47th IEEE Conference on Decision and Control (CDC08), Cancun, Mexico, December 2008. IPC Member of the 13th IFAC Symposium on Information Control Problems in Manufacturing, V. A. Trapeznikov Institute of Control Sciences, Russian Academy of Sciences, Moscow, Russia, June 3-5, 2009. IPC Member of the 9th International IFAC Symposium on Robot Control (SYROCO 2009), Gifu, Japan, September 10-12, 2009. IPC Member of the 2nd Workshop on Engine Control, Simulation and Modeling (E-COSM'09), Paris, November 2009. IPC Member of the Second International Conference on Robot Communication and Coordination (ROBOCOMM 2009), Odense, Denmark, March 31-April 2, 2009. Program Co-Chair of 2009 IEEE Interna-

## *Chapter 10. Staff Activities*

tional Conference on Robotics and Biomimetics (ROBIO 2009), Guilin Guangxi, China, December 12-15, 2009.

### *Johnsson, Charlotta*

Conference Committee Chair for WBF EU'08 Conference "Bridging the divide between IT and Manufacturing", Barcelona, Spain, November 10-12, 2008.

### *Rantzer, Anders*

Member of the IPC for European Control Conference 2010.

## Longer Visits

### *Årzén, Karl-Erik*

Invited lecturer in the one week Artist2 summer school on embedded systems in Autrans, France in September.

### *Johannesson, Erik*

During the fall, Erik was a guest researcher at the University of Maryland where he worked with Dr. Nuno Martins.

### *Nilsson, Oskar*

Spent five weeks at Department of Systems Engineering and Control, Universidad Politécnica de Valencia, Spain, where research concerning model reduction was performed.

# 11. Publications and Conference Contributions

This year 3 books, 4 book contributions, 17 articles and 33 conference papers have been published. You can find references to all the publications at <http://www.control.lth.se/publications> and you can also download many of the publications from this site.

## Books

- Åström K. J. and Murray, R. M: *Feedback Systems - An Introduction for Scientists and Engineers*, Princeton University Press. Princeton, NJ. 2008
- Åström, K. J. and Wittenmark, Björn: *Adaptive Control*, Dover Publications, Mineola, N.Y., 2008. Reprint of book previously published by Addison-Wesley
- Hägglund, Tore: *Praktisk processreglering (Applied Process Control)*, Studentlitteratur, Lund, Sweden, 2008

## Book Contributions

- Gámez García, Javier, Anders Robertsson, Juan Gómez Ortega, Rolf Johansson: "Improvement of Force Control in Robotic Manipulators Using Sensor Fusion Techniques" in *Robot Manipulators*, In-Tech, Vienna, Austria, September 2008. pp. 181-200
- Johansson, Rolf: "Subspace-based Continuous-time Identification" in H. Garnier, L. Wang (Eds.), *Identification of Continuous-time Models from Sampled Data*, Springer-Verlag, London, 2008, pp. 291-309.
- Johansson, Rolf: "Continuous-time Model Identification Using Spectrum Analysis with Passivity-preserving Model Reduction" in H. Garnier, L. Wang (Eds.), *Identification of Continuous-time Models from Sampled Data*, Springer-Verlag, London, 2008, pp. 393-406.

Valera, Angel, F Benimeli, J Solaz, H de Rosario, Anders Robertsson, Klas Nilsson, R Zotovic, M Mellado, E Olmo: "Industrial Robot Force Control. Application to car ingress and egress human movement" in *Recent Advances in Control Systems, Robotics and Automation*, Int Soc for Advanced Research, January 2008. pp. 89-95

## Journal Papers

- Åström, Karl Johan, J. Aracil and F. Gordillo: "A family of smooth controllers for swinging up a pendulum", *Automatica* 44:7 (2008) pp. 1841-1848.
- Åström, Karl Johan and C. Canudas-de-Wit: "Revisiting the LuGre Friction Model", *IEEE Control Systems Magazine* 28:6 (2008) pp. 101-114.
- Ekvall, Jenny and Tore Hägglund: "Improved web break strategy using a new approach for steam pressure control in paper machines", *Control Engineering Practice*, 16, pp. 1151--1160, 2008.
- Fransson, Per-Anders, Magnus Hjerpe, Rolf Johansson: "Adaptation of multi-segmented body movements during vibratory proprioceptive and galvanic vestibular stimulation", *J. Vestibular Research*, 17:1, pp. 47-62, January 2008.
- Freidovich, Leonid, Anders Robertsson, Anton Shiriaev, Rolf Johansson: "Periodic motions of the Pendubot via virtual holonomic constraints: Theory and experiments", *Automatica*, 44:3, pp. 785-791, March 2008.
- Gámez García, Javier, Anders Robertsson, Juan Gómez Ortega, Rolf Johansson: "Self-Calibrated Robotic Manipulator Force Observer", *Robotics and Computer-Integrated Manufacturing*, March 2008, doi: 10.1016/j.rcim.2008.02.003.
- Gámez García, Javier, Anders Robertsson, Juan Gómez Ortega, Rolf Johansson: "Sensor Fusion for Compliant Robot Motion Control", *IEEE Transactions on Robotics*, 24:2, pp. 430-441, April 2008.
- Gomez, Stephen, Mitesh Patel, Sören Berg, Måns Magnusson, Rolf Johansson, P. A. Fransson: "Effects of proprioceptive vibratory stimulation on body movement at 24 and 36 h of sleep deprivation", *Clinical Neurophysiology*, 119:3, pp. 617-625, March 2008.
- Grüne, Lars and Anders Rantzer: "On the Infinite Horizon Performance of Receding Horizon Controllers", *IEEE Transactions on Automatic Control*, 53:9, pp. 2100-2111, October 2008.
- Guzmán, José Luis, Pedro García, Tore Hägglund, Sebastián Dormido, Pedro Albertos, Manuel Berenguel: "Interactive tool for analysis of

- time-delay systems with dead-time compensators”, *Control Engineering Practice*, 16:7, pp. 824-835, 2008.
- Guzmán, José Luis, Karl Johan Åström, Sebastián Dormido, Tore Hägglund, *J. Vestibular Research*, 17:1, pp. 47-62, January 2008. Manuel Berenguel, Yves Piguet: “Interactive Learning Modules for PID Control”, *IEEE Control systems magazine*, pp. 118-134, October 2008.
- Haugwitz, Staffan, Johan Åkesson, Per Hagander: “Dynamic start-up optimization of a plate reactor with uncertainties”, *Journal of Process Control*, <http://dx.doi.org/10.1016/j.jprocont.2008.07.005>.
- Henningsson, Toivo, Erik Johansson, Anton Cervin: “Sporadic Event-Based Control of First-Order Linear Stochastic Systems”, *Automatica*, 44:11, pp. 2890-2895, November 2008.
- Patel, Mitesh, Per-Anders Fransson, D. Lush, H. Petersen, M. Magnusson, R. Johansson, S. Gomez: “The Effects of Foam Surface Properties on Standing Body Movement”, *Acta Otolaryngologica*, 128:9, pp. 952-960, September 2008.
- Patel, Mitesh, S. Gomez, S. Berg, P. Almbladh, J. Lindblad, H. Petersen, M. Magnusson, R. Johansson, P. A. Fransson: “Effects of 24-h and 36-h Sleep Deprivation on Human Postural Control and Adaptation”, *Experimental Brain Research*, 185:2, pp. 165-173, April 2008.
- Purvis, Keith B., Karl Johan Åström, Mustafa Khammash: “Estimation and Optimal Configurations for Localization Using Cooperative UAVs”, *IEEE Transactions on Control Systems Technology*, 16:5, pp. 947-958, September 2008.
- Ståhl, Fredrik and Rolf Johansson: “Diabetes Mellitus Modeling and Short-Term Prediction Based on Blood Glucose Measurements”, *Mathematical Biosciences*, Vol. 217, pp. 101-117.

## Conference Contributions

- Åkesson, Johan: “Optimica—An Extension of Modelica Supporting Dynamic Optimization” in *6th International Modelica Conference 2008*, Modelica Association, March 2008.
- Alriksson, Peter and Anders Rantzer: “Model Based Information Fusion in Sensor Networks” in *Proceedings of the 17th IFAC World Congress*, Seoul, Korea, July 2008.
- Bini, Enrico and Anton Cervin: “Delay-Aware Period Assignment in Control Systems” in *Proc. 29th IEEE Real-Time Systems Symposium*, Barcelona, Spain, December 2008.



- Blom, Daniel, Maria Karlsson, Kent Ekholm, Per Tunestål, Rolf Johansson: “HCCI Engine Modeling and Control Using Conservation Principles” in *SAE World Congress, SAE Technical Paper 2008-01-0789*, Detroit, MI, April 2008.
- Cervin, Anton and Toivo Henningsson: “Scheduling of Event-Triggered Controllers on a Shared Network” in *Proc. 47th IEEE Conference on Decision and Control*, Cancun, Mexico, December 2008.
- Cervin, Anton and Erik Johannesson: “Sporadic Control of Scalar Systems with Delay, Jitter and Measurement Noise” in *Proc. 17th IFAC World Congress*, Seoul, Korea, July 2008.
- Dressler, Isolde, Anders Robertsson, Rolf Johansson: “Automatic Kinematic Calibration of a Modular Gantry-Tau Parallel Robot from a Kinematics Point of View” in *Proc. 2008 IEEE International Conference on Robotics and Automation, Pasadena, CA, USA, May 19-23, 2008*, pp. 1282-1287, May 2008.
- Ekholm, Kent, Maria Karlsson, Per Tunestål, Rolf Johansson, Bengt Johansson, Petter Strandh: “Ethanol-Diesel Fumigation in a Multi-Cylinder Engine” in *SAE World Congress, SAE Technical Paper 2008-01-0033*, Detroit, MI, April 2008.
- Garpinger, Olof and Tore Häggglund: “A Software Tool for Robust PID Design”, in *Proc. 17th IFAC World Congress, Seoul, Korea, July 2008*.
- Guzmán, José Luis, Karl Johan Åström, Sebastián Dormido, Tore Häggglund, Yves Pignet, Manuel Berenguel: “Interactive Learning Module: Basic Modelling and Identification Concepts” in *Proceedings of the 17th World Congress*, Seoul, Korea, July 2008.
- Gäfvert, Magnus, Tomas Skoglund, Hubertus Tummescheit, Johan Windahl, Hans Wikander, Philip Reuterswärd: “Real-Time HWIL Simulation of Liquid Food Process Lines” in *6th International Modelica Conference 2008*, Modelica Association, March 2008.
- Henningsson, Toivo: “Recursive State Estimation for Linear Systems with Mixed Stochastic and Set-Bounded Disturbances” in *Proc. 47th IEEE Conference on Decision and Control*, Cancun, Mexico, December 2008.
- Herreros, Alberto, Enrique Baeyens Lázaro, Jonas Carlson, Rolf Johansson, José Ramón Perán, S. Bertil Olsson: “Analysis of changes in the beat-to-beat P-wave morphology using clustering techniques” in *Proc. 17th IFAC2008 World Congress*, Seoul, Korea, July 6-11, 2008, pp. 5215-5220, July 2008.
- Johansson, Ola and Rolf Johansson: “Model Predictive Control for Scheduling and Routing in a Solid Waste Management System” in

- Proc. 17th IFAC2008 World Congress*, Seoul, Korea, July 6-11, 2008, pp. 4481-4486, July 2008.
- Johansson, Rolf, Joaquín Collado, Rogelio Lozano: “Strictly Positive Real Systems Based on Reduced-Order Observers” in *Proceedings of the 47th IEEE Conference on Decision and Control*, Dec. 9-11, 2008, Cancun, Mexico, December 2008.
- Johnsson, Charlotta: “Graphical Languages for Business Processes and Manufacturing Operations” in *IFAC 2008*, Seoul, South Korea, July 2008.
- Johnsson, Charlotta: “Robotics and ISA 88 Batch Control Standard - Opportunities and Challenges” in *POM 2008*, Tokyo, Japan, August 2008.
- Johnsson, Charlotta: “Graphical Languages for Manufacturing Operations” in *POM 2008*, Tokyo, Japan, August 2008.
- Johnsson, Charlotta: “Teaching Manufacturing Operations and Strategies in Higher Education” in *POM 2008*, Tokyo, Japan, August 2008.
- Karlsson, Maria, Kent Ekholm, Petter Strandh, Rolf Johansson, Per Tunestål: “LQG Control for Minimization of Emissions in a Diesel Engine” in *2008 IEEE International Conference on Control Applications*, September 2008.
- Kjaer, Martin Ansbjerg, Maria Kihl, Anders Robertsson: “Response Time Control of a Processor-Sharing System using Virtualized Server Environments” in *Proc. 17th IFAC World Congress*, Seoul, Korea, pp. 3612-3618, July 2008.
- Kotsalis, Georgios and Anders Rantzer: “Balanced Truncation for a General Class of Discrete-Time Markov Jump Linear Systems” in *American Control Conference 2008*, Seattle, June 2008.
- Larsson, Per-Ola and Tore Hägglund: “Relations Between Control Signal Properties and Robustness Measures” in *Proc. 17th IFAC World Congress*, Seoul, Korea, July 2008.
- Lenain, Roland, Anders Robertsson, Rolf Johansson, Anton Shiriaev, Michel Berducat: “A Velocity Observer Based on Friction Adaptation” in *Proc. 2008 IEEE International Conference on Robotics and Automation Pasadena, CA, USA, May 19-23, 2008*, pp. 3365-3370, May 2008.
- Valera, Angel, F. Benimeli, Jose Solaz, H. de Rosario, Anders Robertsson, Klas Nilsson, R. Zotovic, M. Mellado: “Experimental test-bench development using force control with industrial robots for the analysis of the mechanical response in car seats” in *Proceedings of the 8th Por-*

## Chapter 11. Publications and Conference Contributions

- tuguese Conference on Automatic Control (CONTROLO'2008), Vila Real, Portugal, pp. 777–783, July 2008.*
- Widd, Anders, Per Tunestål, Rolf Johansson: “Physical Modeling and Control of Homogeneous Charge Compression Ignition (HCCI) Engines” in *Proc. 47th IEEE Conference on Decision and Control*, Cancun, Mexico, December 2008.
- Widd, Anders, Per Tunestål, Carl Wilhelmsson, Rolf Johansson: “Control-Oriented Modeling of Homogeneous Charge Compression Ignition incorporating Cylinder Wall Temperature Dynamics” in *Proc. 9th International Symposium on Advanced Vehicle Control*, Kobe, Japan, October 2008.
- Schofield, Brad: “On Active Set Algorithms for Solving Bound-Constrained Least Squares Control Allocation Problems” in *Proceedings of the 2008 American Control Conference*, Seattle, Washington, USA, June 2008.
- Schofield, Brad and Tore Hägglund: “Optimal Control Allocation in Vehicle Dynamics Control for Rollover Mitigation” in *Proceedings of the 2008 American Control Conference*, Seattle, Washington, USA, June 2008.
- Shiriaev, Anton, Rolf Johansson, Anders Robertsson, Leonid Freidovich: “Separation Principle for a Class of Nonlinear Feedback Systems Augmented with Observers” in *Proc. 17th IFAC2008 World Congress*, Seoul, Korea, July 6-11, 2008, pp. 6196-6201, July 2008.
- Ståhl, Fredrik and Rolf Johansson: “Short-Term Diabetes Blood Glucose Prediction Based On Blood Glucose Measurements” in *30th Annual International IEEE EMBS Conference Vancouver, British Columbia, Canada, August 20-24*, August 2008.

## Patent

- Hägglund, Tore: “Automatisk uppskattning av glapp (Automatic Backlash estimation)”. Swedish patent SE 530 380, 2008-05-20.

# 12. Reports

During this year 3 PhD theses have been published. The abstracts are presented in Chapter 7. Also 2 Licentiate theses, 24 Master's theses and 3 internal reports have been completed.

## PhD Theses

Alriksson, Peter: *State Estimation for Distributed and Hybrid Systems*.

PhD thesis ISRN LUTFD2/TFRT--1084--SE, Department of Automatic Control, Lund University, Sweden, September 2008.

Schofield, Brad: *Model-Based Vehicle Dynamics Control for Active Safety*.

PhD thesis ISRN LUTFD2/TFRT--1083--SE, Department of Automatic Control, Lund University, Sweden, September 2008.

Wernrud, Andreas: *Approximate Dynamic Programming with Applications*. PhD thesis ISRN LUTFD2/TFRT--1082--SE, Department of Automatic Control, Lund University, Sweden, February 2008.

## Licentiate Theses

Henningsson, Toivo: *Event-Based Control and Estimation with Stochastic Disturbances*. Licentiate thesis LUTFD2/TFRT--3244--SE, Department of Automatic Control, Lund University, Sweden, November 2008.

Karlsson, Maria: *Control Structures for Low-Emission Combustion in Multi-Cylinder Engines*. Licentiate thesis ISRN LUTFD2/TFRT--3243--SE, Department of Automatic Control, Lund University, Sweden, March 2008.

## Master's Theses

*E = Examiner*

*S = Supervisor*

*AC = Department of Automatic Control, LTH*

Ahlström, Thomas and Claes Bengtsson: "Interference Cancellation in a Full duplex System" Master's thesis ISRN LUTFD2/TFRT--5812--SE, Department of Automatic Control, Lund University, Sweden, March 2008. E: Bo Bernhardsson, AC; S: Peter Jakobsson and Jan Celander, Ericsson AB, Lund.

Alenius, Johannes and Mats Millnert: "The Application of Agent-Based Technology to Packaging Line" Master's thesis ISRN LUTFD2/TFRT--5811--SE, Department of Automatic Control, Lund University, Sweden, March 2008. Anders Rantzer, AC; S: Claudio Donati, TetraPak, Modena, Italy.

Andersson, Patrik: "Investigation of Standard Asynchronous Motors and Synchronous Servo Motors" Master's thesis ISRN LUTFD2/TFRT--5809--SE, Department of Automatic Control, Lund University, Sweden, January 2008. E: Rolf Johnasson, AC; S: Sigvard Birgersson, Sigbi System AB, Helsingborg.

Berntorp, Karl: "ESP for Suppression of Jackknifing in an Articulated Bus" Master's thesis ISRN LUTFD2/TFRT--5831--SE, Department of Automatic Control, Lund University, Sweden, December 2008. E: Karl-Erik Årzén, AC; S: Daniel Kepler and Jens Kalkkül, Daimler AG, Germany.

Björkman, Jonatan: "Control of an Autonomous Wheel Loader" Master's thesis ISRN LUTFD2/TFRT--5822--SE, Department of Automatic Control, Lund University, Sweden, September 2008. Karl-Erik Årzén, AC; S: Torbjörn Martinsson, Volvo, Eskilstuna.

Bresciani, Tammaso: "Modeling, Identification and Control of a Quadroptor Helicopter" Master's thesis ISRN LUTFD2/TFRT--5823--SE, Department of Automatic Control, Lund University, Sweden, October 2008. E: Anders Rantzer, AC; S: Daniele Caltabiano and Roberto Sanino, STMicroelectronics in Milano, Italy.

Carlzén, Robert and Robert Nilsson: "Digital Power Detector for WCDMA Transmitter" Master's thesis ISRN LUTFD2/TFRT--5815--SE, Department of Automatic Control, Lund University, Sweden, June 2008. E: Bo Bernhardsson, AC; S: Jonas Persson and Magnus Nilsson, Ericsson AB, Lund.

- Cescon, Marzia: “Subspace-based Identification of a Parallel Kinematic Manipulator Dynamics” Master's thesis ISRN LUTFD2/TFRT--5814--SE, Department of Automatic Control, Lund University, Sweden, May 2008. E: Rolf Johansson, AC; S: Anders Robertsson, AC.
- Eklund, David and Daniel Rasmusson: “A Home Automation Prototype” Master's thesis ISRN LUTFD2/TFRT--5817--SE, Department of Automatic Control, Lund University, Sweden, May 2008. E: Karl-Erik Årzén, AC; S: Hans Odeberg, ÅK Konsult, Malmö.
- Furmanski, Martin: “Visualization of task execution in ABB 800xA” Master's thesis ISRN LUTFD2/TFRT--5824--SE, Department of Automatic Control, Lund University, Sweden, September 2008. E: Karl-Erik Årzén, AC; S: Gert-Ola Carlsson and Peter L. Nilsson, ABB Process Automation, Malmö.
- Gustafsson, Erik: “Controlling a Robot with Two Force Sensors in a Lead-Through Programming Scenario” Master's thesis ISRN LUTFD2/TFRT--5818--SE, Department of Automatic Control, Lund University, Sweden, June 2008. E: Rolf Johansson, AC; S: Anders Robertsson, AC.
- Haventon, Max and Jakob Öberg: “Testing and implementation of a backlash detection algorithm” Master's thesis ISRN LUTFD2/TFRT--5826--SE, Department of Automatic Control, Lund University, Sweden, November 2008. E: Tore Hägglund, AC; S: Christian Schwerdt, ABB, Malmö.
- Högström, Hans: “Embedded Controller Design for Energy and Climate systems” Master's thesis ISRN LUTFD2/TFRT--5829--SE, Department of Automatic Control, Lund University, Sweden, December 2008. E: Tore Hägglund, AC; S: Anders Robertsson, AC.
- Jönsson, Peter: “Object Tracking with a Mobile Robot using Embedded Linux” Master's thesis ISRN LUTFD2/TFRT--5828--SE, Department of Automatic Control, Lund University, Sweden, January 2008. E: Karl-Erik Årzén, AC; S: Karl Mårtensson, AC, Pablo Cases and Ola Palm, ÅF Combra, Lund.
- Lam, David and Linda Törner: “Modeling and Control of Reaction Calorimeter System” Master's thesis ISRN LUTFD2/TFRT--5813--SE, Department of Automatic Control, Lund University, Sweden, May 2008. E: Per Hagander, AC; S: Hubertus Tummescheit, Modelon AB, Lund; Holger Nilsson and Jan-Bertil Jeppsson, Chemisens AB, Lund.
- Lindgren, Erik: “Preparing the Apache HTTP Server for Feedback Control Application” Master's thesis ISRN LUTFD2/TFRT--5796--SE, Department of Automatic Control, Lund University, Sweden, February

## Chapter 12. Reports

2008. E: Björn Wittenmark, AC; S: Anders Robertsson and Martin Kjaer, AC.
- Linderoth, Magnus: “Vision Based Tracker for Dart Catching Ro-bot” Master's thesis ISRN LUTFD2/TFRT--5830--SE, Department of Automatic Control, Lund University, Sweden, August 2008. E: Rolf Johansson, AC; S: Anders Robertsson, AC and Kalle Åström, Mathematics, Lund University.
- Mattson, Anders: “Using Structure-borne Sound Analysis to Predict Bearing Damages in High-speed Ventilators” Master's thesis ISRN LUTFD2/TFRT--5820--SE, Department of Automatic Control, Lund University, Sweden, June 2008. E: Tore Hägglund, AC; S: Marcus Hoch, AOA Gauting, Germany.
- Notander, Jesper: “Intuitive Lead Through-Programming of Steel Grinding Robots” Master's thesis ISRN LUTFD2/TFRT--5816--SE, Department of Automatic Control, Lund University, Sweden, May 2008. E: Rolf Johansson, AC; S: Anders Robertsson, AC and Jens Hofschule, ABB CRC, Mannheim.
- Persson, Rasmus: “A Bicriteria Simulated Annealing Algorithm for Scheduling Jobs on Parallel Machines with Sequence Dependent Setup Times” Master's thesis ISRN LUTFD2/TFRT--5821--SE, Department of Automatic Control, Lund University, Sweden, September 2008. E: Charlotta Johnsson, AC; S: Imma Ribas, UPC, Barcelona, Spain.
- Pettersson, Pierre: “Estimation of Vehicle Lateral Velocity” Master's thesis ISRN LUTFD2/TFRT--5827--SE, Department of Automatic Control, Lund University, Sweden, November 2008. E: Anders Rantzer, AC; S: Christian Rylander, Haldex, Landskrona.
- Soltész, Kristian: “Trajectory Tracking Control of an Autonomous Ground Vehicle” Master's thesis ISRN LUTFD2/TFRT--5810--SE, Department of Automatic Control, Lund University, Sweden, February 2008. E: Tore Hägglund, AC; S: Richard M. Murray, Caltech, USA.
- Thuring, Patrik: “Model Predictive Control Based Energy Management Algorithm for a Hybrid Excavator” Master's thesis ISRN LUTFD2/TFRT--5825--SE, Department of Automatic Control, Lund University, Sweden, October 2008. E: Anders Rantzer, AC; S: Johan Åkesson, AC.
- Ugander, Johan: “Delay-dependent Stability of Genetic Regulatory Networks” Master's thesis ISRN LUTFD2/TFRT--5819--SE, Department of Automatic Control, Lund University, Sweden, July 2008. E: Anders Rantzer, AC; S: Richard Murray, CIT, USA.

## Internal Reports

- Alriksson, Peter and Karl-Erik Årzén: “A Component-Based Approach to Ultrasonic Self Localization in Sensor Networks” Technical report ISRN LUTFD2/TFRT--7619--SE, Department of Automatic Control, Lund University, Sweden, May 2008.
- Rantzer, Anders: “Using Game Theory for Distributed Control Engineering” Technical report ISRN LUTFD2/TFRT—7620--SE, Department of Automatic Control, Lund University, Sweden, July 2008.
- Tuszynski, Agneta and Karl-Erik Årzén: “Automatic Control 2007. Activity Report” Technical report ISRN LUTFD2/TFRT--4035--SE, Department of Automatic Control, Lund University, Sweden, June 2008.

## Report Availability

Almost all our publications are available in full through our web server at <http://www.control.lth.se/publications>.

Only a limited number of copies of our reports are available for sale from the department. Any of the listed reports may, however, be borrowed through your library service or from the following libraries in Sweden.

- Linköpings Universitetsbibliotek, Svensktrycket, SE-581 83 Linköping
- UniversitetsBiblioteket Lund, Svenska Tryckavdelningen, Box 1010, SE-221 03 Lund
- Stockholms Universitetsbibliotek, Svenska Tryckavdelningen, SE-106 91 Stockholm
- Kungliga Biblioteket, Box 5039, SE-102 41 Stockholm
- Umeå Universitetsbibliotek, Box 718, SE-901 10 Umeå
- Uppsala Universitetsbibliotek, Box 510, SE-751 20 Uppsala

The reports in the 1000- and 3000-series may be ordered from the department (see address on page 2). Please be certain to specify both the number(s) and the title(s) of the report(s). There is a copying and handling charge of between 300 and 500 SEK for each document. Invoice will be sent together with the ordered report(s).



# 13. Lectures by the Staff Outside the Department

*Åkesson, Johan*

*Optimica-An Extension of Modelica Supporting Dynamic Optimization*, 6th International Modelica Conference 2008, Bielefeld, Germany. March 3.

*Languages and Tools for Optimization of Large-Scale Systems*, Oxford University Computing Laboratory, Oxford, UK. May 21.

*Languages and Tools for Optimization of Large-Scale Systems*, Reglermöte 2008, Luleå. Sweden. June 4.

*The JModelica Project-an Overview*, Invited lecture. Royal Institute of Technology, Stockholm, Sweden. September 19.

*Languages and Tools for Optimization of Large-Scale Systems*, Texas A&M University, College Station, USA. October 8.

*Optimica-An Extension of Modelica Supporting Dynamic Optimization*, INFORMS 2008, Washington, USA. October 14.

*Alriksson, Peter*

*Model Based Information Fusion in Sensor Networks*. 17<sup>th</sup> IFAC World Congress, Seoul, South Korea. July 8.

*Årzén, Karl-Erik*

*Adaptivity in Embedded Systems – Why, What and How*, Keynote address at First Workshop on Adaptive and Reconfigurable Embedded Systems, St Louis. April 21.

*The Role of Control in Embedded Computing*, Workshop on Complex Embedded and Networked Control Systems, IFAC World Congress, Seoul. July 5.

*Control design analysis and validation using TrueTime and Jitterbug*, Workshop on Embedded Control Systems; From Design to Implementation, IFAC World Congress, Seoul. July 6.

*Multitasking Real-Time Control Systems in Easy Java Simulations*, IFAC World Congress, Seoul. July 9.

*Implementation of control systems in resource-constrained embedded systems*, ARTIST2 Summer School 2008, Autrans. September 11.

*Åström, Karl Johan*

*Challenges in Control of Buildings*. University of California, Santa Barbara. CA, USA. February 29.

*Bicycle dynamics and control*. Agilent Laboratories, Santa Clara, CA, USA. March 26.

*PID Control and Auto-tuning*. Agilent Laboratories, Santa Clara, CA, USA. March 26.

*Control the Hidden Technology*. Department of Chemical and Materials Engineering. University of Alberta. Edmonton, Canada. May 1.

*Six Decades of Theory and Applications of Control*. International Symposium on Advanced Control of Industrial Processes. Jasper Alberta, Canada. May 5.

*Event Based Control. Analysis and design of nonlinear control systems*. The Royal Society London, UK. May 15.

*May Friction Models and Friction Compensation*. Ilmenau, Germany. May 29.

*Control the Hidden Technology*. United Technology Research Center. Hartford. CT, USA. June 24.

*Control System Architectures*. ARTIST2 Summer School, Autrance, France. September 10.

*Reglerteknik i Perspektiv - Forntid och Framtid*. Norsk forening for Automatisering 50-årsjubileum. (*A Perspective on the Development of Control*. The 50 year anniversary of the Norwegian Association of Automation), Oslo, Norway. October 10.

*In Tune with Bjorn*. The Wittenmark Symposium. Department of Automatic Control. Lund University, Lund, Sweden. October 23.

*Reglerteknikens framtid (A Future of Control)*. Inauguration of the VINNOVA Industry Excellence Center LINK-SIC. Department of Electrical Engineering. Linköpings universitet, Linköping, Sweden. November 10.

*Bicycle Dynamics and Control*. Department of Electrical Engineering. Linköpings universitet, Linköping, Sweden. November 11.

*Alexanderson, reglerteknik och IEEE (Alexanderson, feedback control and IEEE)*. The Alexanderson Symposium. Alexanderson Institute, Grimeton, Varberg, Sweden. December 5.

### *Cervin, Anton*

*Dynamic Scheduling of Event-Based Controllers.* ArtistDesign Workshop on Design for Adaptivity, Lund, Sweden. May 13.

*Integrated Control and Scheduling; Control of Computer Systems; Fixed-point arithmetic.* ARTIST2 Graduate Course on Embedded Control Systems, Stockholm, Sweden. May 27-28.

*Event-Triggered Control of First-Order Systems over a Shared Communication Medium.* Invited lecture at the School of Electrical Engineering, KTH, Sweden. May 29.

*Scheduling of Event-Based Controllers on a Shared Network.* Reglermöte 2008, Luleå, Sweden. June 5.

*Scheduling of Event-Triggered Controllers on a Shared Network.* 47th IEEE Conference on Decision and Control, Cancun, Mexico. December 10.

### *Garpinger, Olof*

*A Software Tool for Robust PID Design,* IFAC World Congress, Seoul, South Korea. July 8.

### *Hägglund, Tore*

*Process Control in Practice,* Industrial course. Stockholm, Sweden. May 7–8.

*Ökad automatiseringsgrad och reglerteknisk utveckling och forskning (Increased level of automation, control development and research),* Mörrum, Sweden. December 16.

### *Johansson, Rolf*

*Force-Controlled Drilling Using Industrial Robot Assembly Operations,* City University of Hong Kong, Hong Kong, China. January 8.

*The Separation Principle in Nonlinear Dynamic Output Feedback Control,* Invited Lecture, the 4th Chinese-Swedish Conference on Control (CSCC 2008), Hong Kong, China. January 10.

*Hybrid Control of Homogeneous Charge Compression Ignition (HCCI) Combustion Engines,* Dept. Applied Mathematics and Physics, Graduate School of Informatics, Kyoto University, Kyoto, Japan. April 4.

*Model Predictive Control for Scheduling and Routing in a Solid Waste Management System,* 17th IFAC2008 World Congress, Seoul, Korea. July 8.

*Separation Principle for a Class of Nonlinear Feedback Systems Augmented with Observers,* 17th IFAC2008 World Congress, Seoul, Korea. July 8.

*System Identification and Adaptation Analysis in Human Postural Control*, Invited Lecture, Neuro-Robotics Symposium—Recent Advances in Sensorimotor Control, Freiburg, Germany. July 22.

*Hybrid Control of Homogeneous Charge Compression Ignition (HCCI) Combustion Engines*, Plenary Lecture, 15th Int. Conference on Automatic Control (Automatics 2008), Odessa, Ukraine. September 26.

*Hybrid Control of Homogeneous Charge Compression Ignition (HCCI) Combustion Engines*, Distinguished Lecture, Hanyang University, Seoul, Korea. November 18.

*Prototype of Novel Parallel Kinematic Manipulator*, Hyundai Heavy Industries, Ltd., Mabuk-dong, Korea. November 20.

*System Identification in Medicine*, Norrland University Hospital, Umeå, Sweden. November 27.

*Strictly Positive Real Systems Based on Reduced-Order Observers*, 47th IEEE Conference on Decision and Control, Cancun, Mexico. December 10.

### *Johannesson, Erik*

*Sporadic Control of Scalar Systems with Delay, Jitter and Measurement Noise*, 17th IFAC World Congress, Seoul, Korea. July 11.

*Sporadic event-based control of first-order linear stochastic systems*, Electrical and Computer Engineering Graduate Student Association seminar series, University of Maryland, USA. October 10.

### *Johnsson, Charlotta*

*“Experter samtalar kring MES (Experts speaking about MES)”* Invited speaker. Charlotta participated in a Round table discussion concerning MES (Manufacturing Execution Systems) organized by Process Nordic. The round table discussion resulted in an article published in Process Nordic’s Magasin. April 17.

*“ISA88 och ISA95: Två standarder med stor relevans för läkemedels-, livsmedels- och bioteknikföretag (ISA88 and ISA95: Two standards with high relevance for pharmaceutical, food and beverage, and biotech industries)”*. Keynote speaker. Charlotta participated as a keynote speaker at Plant Vision’s seminar day around LifeScience in Stockholm. May 7.

*“Make2Pack och ISA88-part5”*. Keynote speaker. Charlotta participated as keynote speaker at Sesam’s meeting in Copenhagen. May 8.

*“MES, Manufacturing Execution System - Finns det någon standard? (MES; Manufacturing Execution Systems – Is there a standard?)”* Invited speaker. Charlotta participated in the conference ”Industrial IT, MES

*Chapter 13. Lectures by the Staff Outside the Department*

and Automation” organized by Process Nordic in Stockholm. November 25.

*Larsson, Per-Ola*

*Relations Between Control Signal Properties and Robustness Measures*, 17th IFAC World Congress, Seoul, Korea. July 9.

*Rantzer, Anders*

*On Distributed Control and Prize Mechanisms*, Chinese-Swedish Control Meeting, Hong Kong. Jan 10.

*Price Mechanisms for Distributed Control Synthesis*, TU Delft, Delft, The Netherlands. Jan 31

*Price Mechanisms for Distributed Control Synthesis*, Oxford University, Oxford, United Kingdom. May 1.

*Price Mechanisms for Distributed Control Synthesis*, Cambridge University, Cambridge, United Kingdom. May 2.

*Using interpolation and matrix inequalities for model reduction in dynamical systems*, Sparr Symposium, Lund. May 8.

*Using Game Theory for Distributed Control Engineering*, World Congress on Game Theory, Evanston, USA. July 13.

*Dual Decomposition for Distributed Control*, International Symposium on Mathematical Theory of Networks and Systems, Blacksburg, USA. July 30.

*Rotational Motion with Almost Global Stability*, Invited lecture, Wolovich Symposium, Cancun, Mexico. December 7.

*Distributed Control using Decompositions and Games*, Semi-plenary lecture, 47th IEEE Conference on Decision and Control, Cancun, Mexico. December 9.

*Robertsson, Anders*

*State Estimation for Friction Compensation and Control*, Invited lecture, 4th Chinese-Swedish Conf. on Ctrl, HKUST, Hong-Kong. January 10-11

*Robotar, cyklar och andra svårstyrda saker*, Popular science lectures at “Naturvetenskap-, Medicin- och Teknikdagarna”. March 2008 .

*Real World Considerations for Using Formal Techniques for Feedback Control in Computing and Network Systems*, Panel member in Febid'08 Annapolis. June 6.

*The Gantru-Tau robot - a new parallel kinematic manipulator*, Exhibition of SMERobot-project at Automatica Fair. June 11-13.

*Force feedback control in robotics*, Invited lecture, Umeå University, October 16.

*Sootla, Aivar*

*On H-infinity model reduction of MIMO systems*, Reglermötet, Luleå, Sweden. June 4-5.

*Widd, Anders*

*Physical Modeling and Control of Homogeneous Charge Compression Ignition (HCCI) Engines*. 47th IEEE Conference on Decision and Control, Cancun, Mexico. December 11.

*Control-Oriented Modeling of Homogeneous Charge Compression Ignition incorporating Cylinder Wall Temperature Dynamics*. 9th International Symposium on Advanced Vehicle Control, Kobe, Japan. October 7.

*Physics-based Modeling and Control of HCCI Engines*. Reglermöte 2008, Luleå, Sweden. June 4.

# 14. Seminars at the Department

Seminars are presented in order of date. The seminars were given at the department during 2008, both by the staff and invited lecturers. Dissertations and master's theses presentations are also included.

*AC = Department of Automatic Control, LTH*

*LU = Lund University*

Jan 24: Patrik Andersson (LU), *Investigation of Standard Asynchronous Motors and Synchronous Servo Motors*. MSc-thesis presentation.

Jan 25: Chung-Yao Kao (University of Melbourne, Australia), *On Robustness of Discrete-Time Systems with Varying Time Delay*.

Feb 27: Marzia Cescon (LU), *Subspace-based system identification of a Parallel Kinematic Manipulator dynamics*. MSc-thesis presentation.

Feb 28: Lars Grüne (Universität Bayreuth, Germany), *Analysis and design of nonlinear model predictive control schemes without terminal constraints*.

Feb 28: Wolfgang Reinelt (ELAU, Germany), *Packaging machines and their control engineering challenges*.

Feb 29: Andreas Wernrud (AC), *Approximate Dynamic Programming with Applications*. Defence of Doctoral Dissertation.

Feb 29: Pablo A. Parrilo (MIT, US), *Finding Minimum-Rank Matrices via Nuclear Norm Minimization*.

Mar 6: Thomas Ahlström and Claes Bengtsson (LU), *Interference cancellation in a full Duplex System*. MSc-thesis presentation.

Mar 26: Richard M. Murray (CIT, US), *Information Dynamics for Networked Feedback Systems*.

Mar 26: Maben Rabi (KTH, Sweden), *Designing Event-Triggered Control by Optimization*.

Mar 27: Luigi del Re (Johannes Kepler University, Austria), *Which Predictive Approach for Engine Control?*

Mar 28: Maria Karlsson (AC), *Control Structures for Low-Emission Combustion in Multi-Cylinder Engines*. Licentiate seminar.

- Apr 11: David Lam and Linda Törner (LU), *Modeling and control of reaction calorimeter system*. MSc-thesis presentation.
- Apr 11: Robert Carlzén and Robert Nilsson (LU), *Digital power detector for W-CDMA transmitter*. MSc-thesis presentation.
- May 5: Anders Mattson (LU), *Using Structure-borne Sound Analysis to Predict Bearing Damages in High-speed Ventilators*. MSc-thesis presentation.
- May 14: Johan Sjöberg (LiTH, Linköping), *Optimal Feedback Control of Nonlinear DAE Models*.
- May 16: Hans Hydén and Per Wilhelmsson (LU), *Exposure control in network video cameras with and without variable aperture*. MSc-thesis presentation.
- June 17: Erik Gustafsson (LU), *Controlling a Robot through Two Force Sensors in a Lead Through Programming Scenario*. MSc-thesis presentation.
- June 18: Donald M. Wiberg (University of California, US), *Astronomy, Cosmology and Control Systems: Instrumentation for Understanding the Universe through Adaptive Optics*.
- June 19: Donald M. Wiberg (University of California, US), *A Fix-Up for the EKF Parameter Estimator*.
- June 24: David Eklund and Daniel Rasmusson (LU), *A Home Automation Prototype*. MSc-thesis presentation.
- Aug 19: Cedric Langbort (University of Illinois at Urbana-Champaign, US), *New Directions in Distributed Control*.
- Aug 19: Jose Vasconcelos (Institute for Systems and Robotics, Instituto Superior Técnico, Portugal), *A Nonlinear Observer for Rigid Body Attitude Estimation on  $SO(3)$  using Inertial Measurements and Vector Observations*.
- Aug 26: Johan Ugander (LU), *Delay-dependent Stability of Genetic Regulatory Networks*. MSc-thesis presentation.
- Aug 26: John S. Baras (University of Maryland College Park, US), *Constrained Coalition Games and Networks of Autonomous Agents*.
- Aug 26: Jonathan Björkman (LU), *Control of an Autonomous Wheel Loader*. MSc-Thesis presentation.
- Aug 27: Magnus Linderöth (LU), *Vision Based Tracker for Dart Catching Robot*. MSc-thesis presentation.
- Sep 4: Karl Johan Åström (AC), *A Future for Control*.
- Sep 11: Rasmus Persson (LU), *A Bicriteria Simulated Annealing Algorithm for Scheduling jobs on Parallell Machines with Dependent Setup Times*. MSc-thesis presentation.



*Chapter 14. Seminars at the Department*

- Sep 16: Martin Furmanski (LU), *On-line task visualization for ABB 800xA controller*. MSc-thesis presentation.
- Sep 19: Brad Schofield (AC), *Model-Based Vehicle Dynamics Control for Active Safety*. Defence of Doctoral Dissertation.
- Sep 25: Akira Ohata (Toyota Motor Corporation, Japan), *Improving Model-based Development for Automotive Control Systems*.
- Sep 25: Shigeru Ohu (Hitachi Ltd, Japan), *Model-Based Implementation Design of Automotive Controllers*.
- Sep 25: Raffaello D'Andrea (ETH, Switzerland), *Design and Control of Autonomous Systems*.
- Sep 29: Peter Aliksson (AC), *State Estimation for Distributed and Hybrid Systems*. Defence of Doctoral Dissertation.
- Sep 30: Patrik Thuring (LU), *Model Predictive Control Based Energy Management Algorithm for a Hybrid Excavator*. MSc-thesis presentation.
- Oct 3: Sergei Silvestrov (Mathematics LTH, Sweden), *Non-communicative Matrix Equations and Dynamical Systems – A Fruitful Interplay*.
- Oct 13: Tommaso Bresciani (LU), *Modelling, Identification and Control of a Quadrotor Helicopter*. MSc-thesis presentation.
- Oct 24: Ian Manchester (Umeå University, Sweden), *Undereducated Biped Robots: New Techniques for Motion-Planning and Control*.
- Oct 24: Staffan Haugwitz (Borealis, Sweden), *Development and commissioning of nonlinear MPC controllers in a polypropylene plant*.
- Nov 4: Peter Jönsson (LU), *Object Tracking with a Mobile Robot using Embedded Linux*. MSc-thesis presentation.
- Nov 6: Pierre Pettersson (LU), *Estimation of Vehicle Lateral Velocity*. MSc-thesis presentation.
- Nov 12: Jörn Janneck (Xilinx, USA), *Dataflow Programming for Hardware and Software*.
- Nov 12: Douglas MacMynowski (Caltech AB, Sweden), *Control of the Thirty Meter Telescope*.
- Nov 21: Max Haventon and Jakob Öberg (LU), *Testing and implementation of a backlash detection algorithm*. MSc-thesis presentation.
- Nov 27: Mikael Johansson (KTH, Sweden), *Novel Algorithms for Peer-to-peer Optimization in Networked Systems*.
- Nov 28: Toivo Henningson (AC), *Event-Based Control and Estimation with Stochastic Disturbances*. Licentiate seminar.
- Dec 2: Anders Rantzer (AC), *Rotational motion with almost global stability*.

*Chapter 14. Seminars at the Department*

- Dec 2: Anders Rantzer (AC), *Distributed Control Using Decompositions and Games*.
- Dec 5: Hans Högström (LU), *Embedded Controller Design for Energy and Climate systems*. MSc-thesis presentation.
- Dec 16: Karl Berntorp (LU), *Coordination between ESP and anti-jack-knife system in a linked bus*. MSc-thesis presentation.