

# Acute Symptoms of Posttraumatic Stress and Dissociative Experiences Among Female Israeli Civilians Exposed to War: The Roles of Intrapersonal and Interpersonal Sources of Resilience

Avi Besser,<sup>1</sup> Michael Weinberg,<sup>2</sup> Virgil Zeigler-Hill,<sup>3</sup> and Yuval Neria<sup>4,5</sup>

<sup>1</sup>*Sapir Academic College*

<sup>2</sup>*University of Haifa*

<sup>3</sup>*Oakland University*

<sup>4</sup>*New York State Psychiatric Institute*

<sup>5</sup>*Columbia University Medical Center*

**Background:** The positive personality characteristics of optimism, hope, self-esteem, and perceived availability of social support are believed to play an important role in psychological adjustment to stressful life events. For example, these characteristics have been shown to be associated with fewer mood disturbances in response to a variety of stressors. However, relatively little is known about the extent to which these characteristics serve as sources of resilience among civilians during real-time exposure to war. **Objective:** This “natural laboratory” study examined the role that individual differences both in *intrapersonal* (i.e., positive personality features of hope, optimism, and self-esteem) and in *interpersonal* (i.e., perceived social support from family, friends, and significant others) sources of resilience may play in the development of acute anxiety symptoms of posttraumatic stress disorder (PTSD) and dissociative experiences during exposure to war. **Method:** A nonclinical community sample of 140 female adults was assessed during real-time exposure to missile and rocket fire during an eruption of violence in the Middle East in November 2012. **Results:** The results demonstrate that both intrapersonal and interpersonal sources of resilience were negatively associated with acute PTSD and dissociative symptoms. **Conclusion:** The findings of this study provide evidence that both intrapersonal and interpersonal sources of resilience may significantly mitigate the risk for acute anxiety symptoms among civilian communities exposed to traumatic events. © 2014 Wiley Periodicals, Inc. *J. Clin. Psychol.* 70:1227–1239, 2014.

Keywords: hope; optimism; self-esteem; PTSD; dissociative experiences; social support, war zone; trauma, resilience

Extensive research has been devoted to studying the mental health outcomes of exposure to ongoing war and terrorism (e.g., Hoffman, Diamond, & Lipsitz, 2011). Research has demonstrated that such exposure may significantly increase a range of mental health problems including fear, arousal, and diminished sense of safety (Weinberg, Besser, Campeas, Shvil, & Neria, 2012). Over a period of 13 years, large civilian populations in southwestern Israel have been exposed to missile fire from across the Gaza–Israel border, but relatively few studies have focused on the mental health effects of these incidents on civilian populations (see Weinberg et al., 2012 for a review of this work). Recently, the Israeli–Palestinian conflict escalated and more than 2,300 rockets were launched at Israel, with over 1,500 of these launches taking place during the data collection phase of the present study (November 14–21, 2012).

Although numerous studies have documented the substantial psychological morbidity of direct exposure to terrorism by highlighting the risk of acute anxiety symptoms, particularly

---

Grateful thanks are extended to all those who participated in this study and to the anonymous reviewers for their constructive suggestions and comments on a draft of this article.

Please address correspondence to: Avi Besser, Center for Research in Personality, Life Transitions, and Stressful Life Events, Sapir Academic College, D. N. Hof Ashkelon 79165, Israel. E-mail: besser@mail.sapir.ac.il

posttraumatic stress disorder (PTSD) symptoms (e.g., Neria, Nandi, & Galea, 2008), it is important to note that the psychological effects of trauma exposure often includes anxiety symptoms that extend beyond PTSD. For example, previous research has described a variety of dissociative experiences including disruption of normally integrated functions of consciousness, memory, identity, or perception of the environment after traumatic experiences (e.g., Van Duijl, Nijenhuis, Komproe, Gemaat, & de Jong, 2010). In fact, dissociative experiences have been reported as a prominent psychological outcome likely to emerge in response to traumatic events (Ozer, Best, Lipsey, & Weiss, 2003).

### *Intrapersonal Sources of Resilience: Hope, Optimism, and Self-Esteem*

Recent studies of positive personality features have revealed that the characteristics of hope, optimism, and self-esteem have been found to be associated with how individuals perceive and respond to potential stressors, ranging from mundane events such as beginning college studies (e.g., Besser & Zeigler-Hill, in press) to extreme events such as exposure to missile attacks (e.g., Weinberg, Besser, Zeigler-Hill, & Neria, in press). The first source of intrapersonal resilience is *hope*, which involves the belief that an individual will be able to find a way to reach his or her goals (e.g., Snyder, Rand, & Sigmon, 2002). Hope is generally thought to be a positive motivational state that is based on an interactively derived sense of successful agency (goal-directed energy) and pathways (planning to meet goals; Snyder et al., 1991). There is a cognitive basis to hope that pertains to information and goals at the same time that hope also has motivational qualities (Folkman, 2010). Although individuals who tend to experience higher levels of hope have been found to report greater positive affect, it is important to note that hope is not generally considered to be an emotion per se. Rather, hope is most often considered to be a state of mind that is associated with a range of positive emotions.

The tendency to experience hope has been found to be associated with positive responses to stressful situations (e.g., Affleck & Tennen, 1996; Folkman, 2010). Studies have consistently demonstrated that hope can promote better psychological adjustment (Kwon, 2002) and general well-being (Magaletta & Oliver, 1999), and serve as an important source of resilience for individuals going through potentially traumatic events (e.g., Ho, Ho, Bonanno, Chu, & Chan, 2010). These findings provide initial support for the possibility that feelings of hope may protect against psychological distress for individuals who experience traumatic events. Consistent with this idea, hope has been found to be negatively associated with PTSD symptoms and psychological distress among trauma survivors (e.g., Gilman, Schumn, & Chard, 2012).

*Optimism* and *self-esteem* are other sources of intrapersonal resilience that have been found to be associated with responses to stressful situations. Positive psychological states, such as being optimistic or having a high level of self-esteem, are believed to provide individuals with an array of coping resources (e.g., attentional, cognitive, and behavioral) that can be used to more effectively deal with negative life events (Fredrickson, 2001; Taylor, Kemeny, Reed, Bower, & Gruenewald, 2000). Higher levels of dispositional optimism have been shown to be related to a variety of outcomes, including well-being in times of stress (Besser & Zeigler-Hill, in press) or adversity (Carver, Scheier, & Segerstrom, 2010) and more adaptive responses to traumatic events (Prati & Pietrantonio, 2009), such as illness (e.g., Kivimäki et al., 2005), disasters (Samoon et al., 2010), terrorism (Ai, Evans-Campbell, Santagello, & Cascio, 2006; Besser, Zeigler-Hill, Pincus, & Neria, 2013), and war trauma (Thomas, Britt, Odle-Dusseau, & Bliese, 2011).

Similar results have been found for high levels of self-esteem, which have been shown to predict various outcomes including success (Baumgardner, 1991), reduced mood swings (Campbell, Chew, & Scratchley, 1991), and depression (Hokanson, Rubert, Welker, Hollander, & Hedeon, 1989), as well as psychological well-being and health during stressful situations (Baumeister, Campbell, Krueger, & Vohs, 2003). Among survivors of traumatic events, high levels of self-esteem have been found to be associated with low levels of emotional distress and fewer PTSD symptoms (e.g., Boscarino, Adams, & Figley, 2004; Kashdan, Uswatte, Steger, & Julian, 2006) and dissociative experiences (Weinberg et al., in press).

### *Interpersonal Sources of Resilience: Social Support*

The extant literature concerning perceived social support suggests that it is associated with lower levels of anxiety, depression, and behavioral distress after stressful life events (Russell & Cutrona, 1991). Previous findings have indicated that it is the *perception* of social support, rather than the actual support received, that plays an important role in predicting coping effectiveness, psychological well-being, and physical health (e.g., Dolbier & Steinhardt, 2000). Perceived social support is a primary interpersonal resource that has been consistently found to be associated with psychological well-being in times of stress (Norris & Kaniasty, 1996). It is also considered to be a protective factor for individuals who have experienced disasters (Norris et al., 2002), terror attacks (e.g., Weinberg et al., 2012), or other potentially life-threatening situations (e.g., Norris & Kaniasty, 1996; Shalev, Tuval, Frenkiel-Fishman, Hadar, & Eth, 2006).

In meta-analyses, Brewin, Andrews, and Valentine (2000) and Ozer and colleagues (2003) suggested that while a lack of social support is one of the most powerful risk factors for PTSD, perceived availability of social support was linked to resilience and recovery with regard to PTSD. What remains unknown, however, is the relative contribution of intrapersonal (positive personality features) and interpersonal (perceived social support) sources of resilience to acute symptoms after traumatic experiences.

### *The Present Study*

The primary purpose of the present research was to extend our understanding of the roles that intrapersonal (i.e., hope, optimism, and self-esteem) and interpersonal (i.e., perceived social support from family, friends, and significant others) sources of resilience play in mitigating civilians' responses to traumatic experiences during times of war. Previous research has demonstrated that both intrapersonal and interpersonal sources of resilience are associated with more positive psychological adjustment after stressful life events. However, relatively little is known about the capacity of these sources to substantially buffer traumatic experiences during real-time exposure of civilians to war.

To accomplish this goal, the present study examined the associations between the intrapersonal and interpersonal sources of resilience and acute anxiety symptoms (i.e., symptoms of PTSD and dissociative experiences) among Israeli civilians confronted with rocket and missile fire. Specifically, we hypothesized that intrapersonal and interpersonal sources of resilience would have negative associations with acute anxiety symptoms during real-time exposure to rocket and missile attacks, even when we controlled for their shared variance.

## Method

The data for the present study were taken from a larger project designed to study the mental health consequences of the 2012 Israel–Gaza war (e.g., Besser et al., 2013; Weinberg et al., in press). The present study is based on the real-time responses to a survey among civilians facing high levels of potential threat from missile fire originating from the Gaza Strip during the “Pillar of Defense” Israel Defense Forces operation that lasted from November 14, 2012 to November 21, 2012.

### *Subjects*

The sample consisted of 140 Jewish Israeli adult female civilians who lived in southwestern Israel (7 km–40 km from the Gaza border). Participants were a community sample under severe threat and their proximity to the border allowed them less than 15 seconds of warning with regard to incoming missile and rocket strikes at the time they completed the survey. The average age of participants was 25.21 years (standard deviation [*SD*] = 5.49) and they had completed an average of 13.18 years (*SD* = 1.88) of formal education. Of the sample, 81.4% were born in Israel; 95% were employed or enrolled as a university student; 76.4% were single, 22.9% were married, and

0.7% were divorced/separated; 46.4% were religious; and 55% reported their economic status as low/average, 43.6% as good, and 1.4% as high.

### Measures

**Optimism.** The Life Orientation Test-Revised (LOT-R; Scheier, Carver, & Bridges, 1994) was used to assess optimism and comprises 10 items: six relevant items (e.g., "In uncertain times, I usually expect the best") and four irrelevant items (e.g., "It's easy for me to relax"). Participants provide a response for each item using scales ranging from 0 (*I disagree a lot*) to 4 (*I agree a lot*). The questionnaire uses the average score of the six relevant items to capture optimism. The LOT-R has demonstrated adequate psychometric properties in past research (e.g., Scheier et al., 1994).

**Hope.** The Trait Hope Scale (Snyder et al., 1991) was used to measure hope and comprises 12 items (eight relevant items, e.g., "There are lots of ways around any problem," and four irrelevant items, e.g., "I feel tired most of the time"). Respondents provide a response for each item using a 4-point scale ranging from 1 (*definitely false*) to 4 (*definitely true*). This instrument uses the average score of the eight relevant items to capture dispositional hope. The Trait Hope Scale has been found to possess adequate psychometric properties in past research (acceptable internal consistency estimates, test-retest reliabilities, and concurrent and discriminant validities; e.g., Snyder et al., 1991).

**Self-esteem.** The Rosenberg Self-Esteem Scale (Rosenberg, 1965) was used to assess global self-esteem. The scale comprises 10 items (e.g., "On the whole, I am satisfied with myself") that respondents were instructed to complete according to how they feel about themselves. Responses were made on a 5-point scale ranging from 1 (*strongly disagree*) to 5 (*strongly agree*). The instrument is regarded as a well-validated and reliable measure of global self-regard (e.g., Blascovich & Tomaka, 1991).

**Perceived social support.** The Multidimensional Scale of Perceived Social Support (MSPSS; Zimet, Dahlem, Zimet, & Farley, 1988) was used to assess self-reported amounts of social support. The MSPSS is a 12-item questionnaire containing three subscales, each comprising four items, measuring perceived availability of social support from friends, family, and one's significant other. Responses were made on a 7-point scale ranging from 1 (*very strongly disagree*) to 7 (*very strongly agree*) for each item. For this study, we calculated an overall MSPSS score (see Canty-Mitchell & Zimet, 2000 for more information on the psychometric properties of this instrument).

**PTSD.** The PTSD Checklist-Civilian Version (PCL-C; Weathers & Ford, 1996) was used to assess symptoms of PTSD. The PCL-C is a 17-item questionnaire based on clinical diagnostic criteria, which relate to three separate PTSD symptom clusters: re-experiencing (e.g., "Suddenly acting or feeling as if a stressful experience was happening again [as if you were reliving it]?"); numbing/avoidance (e.g., "Avoiding activities or situations because they reminded you of your stressful experience?"); and hyperarousal (e.g., "Having difficulty concentrating?"). Respondents were asked to rate the symptoms of PTSD they experienced during the past month as related to the fighting between Israel and Hamas (i.e., rocket and missile fire) on a 5-point scale ranging from 1 (*not at all*) to 5 (*extremely*). The total score on the PCL-C was our index of PTSD symptoms, which ranged from 17 to 85, with higher scores representing higher levels of PTSD symptoms.

**Dissociative experiences.** The Dissociative Experiences Scale (DES; Bernstein & Putnam, 1986) was used to evaluate dissociative experiences. The DES is a 28-item questionnaire based on diagnostic criteria with scores ranging from 0% to 100% (to indicate the percentage of the time the respondent has had these experiences), such that higher scores indicate higher levels of dissociative symptoms. The DES contains a variety of dissociative experiences, many of which

are normal experiences such as depersonalization (e.g., “Some people have the experience of driving a car and suddenly realizing that they don’t remember what has happened during all or part of the trip”), absorption (e.g., “Some people find that when they are watching television or a movie they become so absorbed in the story that they are unaware of other events happening around them”), and memory disturbances (e.g., “Some people have the experience of finding themselves in a place and having no idea how they got there”). The DES is regarded as a well-validated and reliable measure of dissociative experiences (Zucker, Spinazzola, Blaustein, & van der Kolk, 2006).

### *Procedures*

The goal of the study was to investigate resilience and acute anxiety under in vivo, life-threatening conditions. To accomplish that, questionnaires were administered via the Internet, which allowed simultaneous data collection from individuals across the region of Israel that was experiencing the greatest exposure to rocket and missile attacks. Participants completed these measures during a period of time when they were experiencing some level of threat (i.e., invitations to participate were sent on November 14, 2012 and data collection closed at the time of the declaration of a ceasefire on November 21, 2012).

We recruited a convenience sample of nonclinical participants, using a snowball sampling effort that utilized Internet-based social media outlets (e.g., Facebook), and invited individuals in this region to participate in the study and to consider inviting their friends to take part in the study as well. We excluded men from our final sample because their participation rate was extremely low (i.e., only seven men completed the questionnaires). The low participation rate of men may have been due, at least in part, to the fact that many men were drafted into active service during this conflict. The study was approved by the Sapir College, Department of Behavioral Sciences Ethical Committee, ensuring privacy and confidentiality. All respondents provided electronic informed consent before participating in the study.

### *Data Analysis*

Analyses focused on the direct and combined associations that intrapersonal (i.e., positive personality features of hope, optimism, and self-esteem) and interpersonal (i.e., perceived social support from family, friends, and significant others) had with acute anxiety symptoms (i.e., symptoms of PTSD and dissociative experiences). The proposed model was investigated in two stages using structural equation modeling (SEM; Hoyle & Smith, 1994).

First, the direct associations that intrapersonal (Figure 1A) and interpersonal (Figure 1B) sources of resilience had with acute anxiety symptoms were analyzed. Second, the model was specified that included the associations that both intrapersonal and interpersonal sources of resilience had with acute anxiety symptoms (Figure 2). All analyses were conducted with AMOS (version 18; Arbuckle, 2009) using the maximum-likelihood method. These analyses concerned three latent factors: intrapersonal sources of resilience defined by the three positive personality features as indicators (i.e., levels of hope, optimism, and self-esteem); interpersonal sources of resilience defined by the three social support as indicators (i.e., levels of support from family, friends, and significant others); and acute anxiety symptoms that was defined by two indicators (i.e., symptoms of PTSD and dissociative experiences).

In addition to the overall  $\chi^2$  test of exact fit, the following fit indices were used to evaluate the proposed models: (a) the  $\chi^2$ /degree of freedom (*df*) ratio; (b) the root mean square error of approximation (RMSEA); (c) the comparative fit index (CFI); and (d) the non-normed fit index (NNFI). A model in which  $\chi^2/df$  was  $\leq 2$ , CFI and NNFI were greater than 0.90, and the RMSEA index was between 0.00 and 0.09 (Hu & Bentler, 1999) was deemed acceptable. These moderately stringent acceptance criteria clearly reject inadequate or poorly specified models, while accepting models for consideration that meet real-world criteria for reasonable fit and representation of the data (Kelloway, 1998).

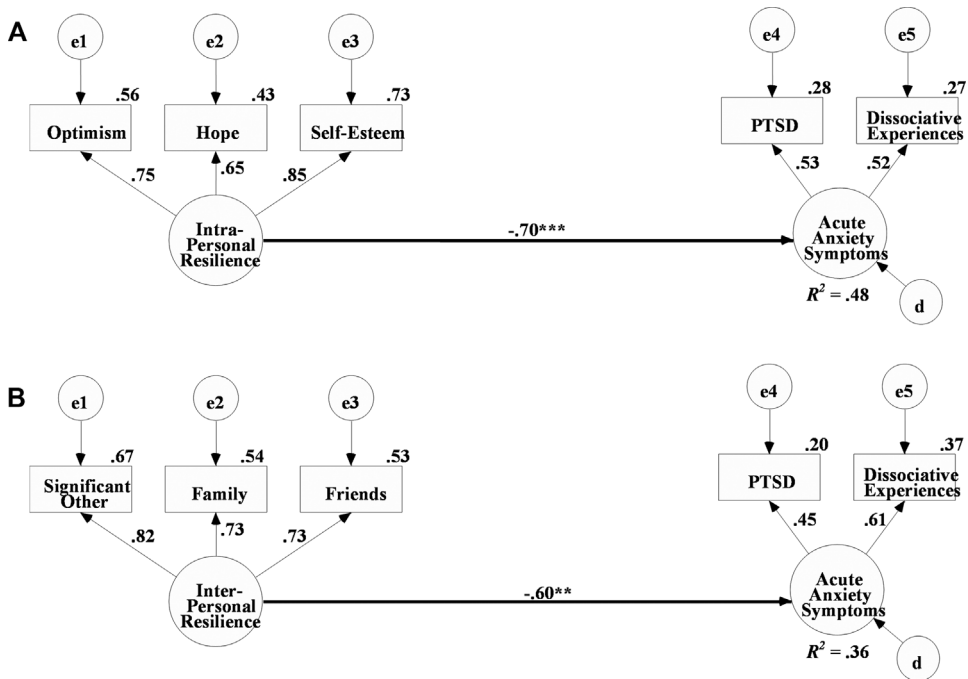

Figure 1. The relationship between intrapersonal resilience and acute anxiety symptoms is depicted in panel A and the relationship between interpersonal resilience and acute anxiety symptoms is depicted in panel B.

Note. Rectangles indicate measured variables and large circles represent latent constructs. Small circles reflect residuals (e) or disturbances (d); bold numbers above or near endogenous variables represent the amount of variance explained ( $R^2$ ). Unidirectional arrows depict hypothesized association. Standardized maximum likelihood parameters are used. Bold estimates are statistically significant.  $N = 140$ . \*\* $p < 0.01$ . \*\*\* $p < 0.0001$  (two-tailed).

## Results

Table 1 presents the zero-order correlations between the study variables. Optimism, hope, and self-esteem were positively correlated with each other as well as with perceived social support from family, friends, and significant others. Acute symptoms of PTSD and dissociative experiences were positively correlated with each other. The positive personality features and the sources of perceived social support were negatively correlated with acute symptoms of PTSD and dissociative experiences.<sup>1</sup>

### Competing Predictors Analyses

**Direct association models.** The SEM model used to test the direct association between intrapersonal sources of resilience and acute anxiety symptoms (see Figure 1A) fit the observed data very well,  $\chi^2(4) = 2.54$ ,  $p > 0.64$ ,  $\chi^2/df = 0.64$ , NNFI = 0.99, CFI = 1.0, RMSEA = 0.0001. The SEM model used to test the direct association between interpersonal sources of resilience and acute anxiety symptoms (see Figure 1B) fit the observed data very well,  $\chi^2(4) = 5.87$ ,  $p > 0.21$ ,  $\chi^2/df = 1.47$ , NNFI = 0.97, CFI = 0.99, RMSEA = 0.06. As indicated in Figure 1A, the association between intrapersonal sources of resilience and acute anxiety symptoms was

<sup>1</sup>We examined the possibility that religious faith may be a potential source of resilience for some participants. However, we found that religious faith (*religious* = 1 and *non-religious* = -1) was not significantly associated with any of the other variables in the study in preliminary analyses nor did it moderate any of the results that we have reported. As a result, religious faith was not included in the final analyses.

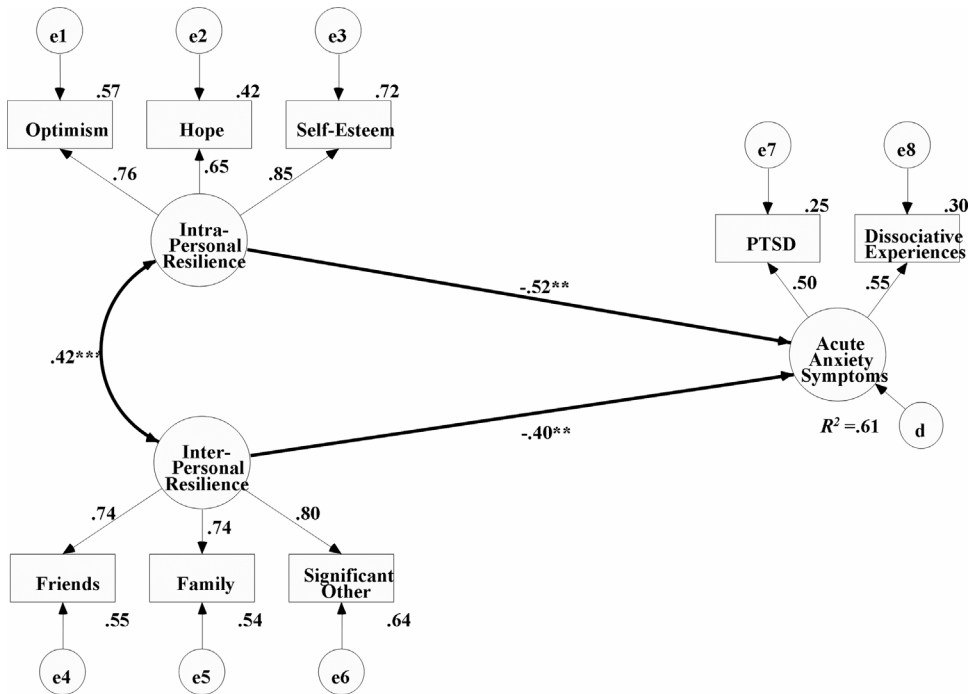

Figure 2. Combined relationships between intrapersonal and interpersonal resilience and acute anxiety symptoms.

Note. Rectangles indicate measured variables and large circles represent latent constructs. Small circles reflect residuals (e) or disturbances (d); bold numbers above or near endogenous variables represent the amount of variance explained ( $R^2$ ). Uni/bi directional arrows depict hypothesized association. Standardized maximum likelihood parameters are used. Bold estimates are statistically significant.  $N = 140$ .  $**p < 0.01$ .  $***p < 0.0001$  (two-tailed).

significant ( $\beta = -0.70$ ,  $t = -3.98$ ,  $p < 0.0001$ ). This model explained 48% of the variance in acute anxiety symptoms. As indicated in Figure 1B, the association between interpersonal sources of resilience and acute anxiety symptoms was also significant ( $\beta = -0.60$ ,  $t = -2.83$ ,  $p < 0.005$ ). This model explained 36% of the variance in acute anxiety symptoms.

**Combined associations model.** The SEM model that included intrapersonal sources of resilience, interpersonal sources of resilience, and acute anxiety symptoms (see Figure 2) fit the observed data very well,  $\chi^2(17) = 26.43$ ,  $p > 0.07$ ,  $\chi^2/df = 1.55$ , NNFI = 0.93, CFI = 0.97, RMSEA = 0.06. Intrapersonal resilience and interpersonal resilience had a significant association ( $r = 0.42$ ,  $t = 3.41$ ,  $p < 0.001$ ) and both had significant associations with acute anxiety symptoms ( $\beta = -0.52$ ,  $t = -2.92$ ,  $p < 0.003$  and  $\beta = -0.40$ ,  $t = -2.55$ ,  $p < 0.01$  for intrapersonal and interpersonal sources of resilience, respectively). This model explained 61% of the variance in acute anxiety symptoms. The model that included both intrapersonal and interpersonal sources of resilience added 13% to the explained variance in acute anxiety symptoms, beyond what was explained by the direct association of intrapersonal sources of resilience and 25% above the variance explained by the interpersonal resilience's direct association model.

## Discussion

The primary goal of the study was to examine the roles played by individual differences in intrapersonal (positive personality features of hope, optimism, and self-esteem) and interpersonal (perceived social support from family, friends, and significant others) sources of resilience in mitigating acute anxiety symptoms among Israeli civilians exposed to missile attacks. Consistent

Table 1  
Zero-Order Correlations Between the Study Variables

Variables	1	2	3	4	5	6	7	8	M	SD	$\alpha$
<i>Intrapersonal sources of resilience</i>											
<i>Positive personality features</i>											
1. Optimism	—								16.15	3.97	.80
2. Hope	.51***	—							46.11	8.46	.87
3. Self-esteem	.63***	.56***	—						4.17	0.65	.89
<i>Interpersonal sources of resilience</i>											
<i>Social support</i>											
4. Significant others	.28***	.05	.21*	—					5.94	1.33	.80
5. Family	.26**	.24**	.27**	.62***	—				6.04	1.30	.83
6. Friends	.33***	.16*	.37***	.60***	.51***	—			6.34	1.04	.78
<i>Acute anxiety symptoms</i>											
7. PTSD	-.31***	-.18*	-.32***	-.18*	-.17*	-.29***	—		40.38	15.01	.91
8. Dissociation experiences	-.25**	-.20*	-.33***	-.26**	-.30***	-.31***	.27***	—	11.63	10.28	.92

Note. M = mean; SD = standard deviation; PTSD = posttraumatic stress disorder.  
N = 140. \* $p < .05$ . \*\* $p < .01$ . \*\*\* $p < .001$ , two-tailed.



with previous research demonstrating the links that hope, optimism, and self-esteem have with well-being and psychological distress under stressful situations (e.g., Weinberg et al., in press), the present findings showed a negative association between intrapersonal sources of resilience and acute anxiety symptoms.

Moreover, the present study demonstrated that hope, optimism, and self-esteem provide protection for individuals after traumatic experiences. These characteristics appear to enable individuals to expect positive outcomes after traumatic events and may play roles in protecting individuals from experiencing fear and its associated psychopathology during potentially life-threatening situations.

We also considered the possibility that religious faith may serve as a potential source of resilience. However, our preliminary analyses found that religious faith was not significantly associated with any of the other variables in the study, nor did it moderate any of the results that we have reported. Future studies should continue to consider the possibility that religious faith serves as a potential source of resilience, even though we did not find any evidence of this in the present study.

Together, the present findings provide support for the hypothesis that intrapersonal (hope, optimism, and self-esteem) and interpersonal (perceived social support from family, friends, and significant others) sources of resilience would have unique associations with acute symptoms after traumatic experiences. These findings are consistent with previous results showing that hope and family support were associated with PTSD symptoms among children who experienced rocket attacks in Israel (Kasler, Dahan, & Elias, 2008).

The present study has a number of strengths, including our use of a sample of participants assessed *during* continuous life-threatening rocket fire and missile attacks, rather than relying on retrospective approaches that may significantly mitigate recall bias. Despite its strengths, the study also has a number of potential limitations. First, the “real time” data collection strategy utilized here may have restricted how the outcomes may play out over time, which is important because recovery and adjustment after exposure to a potentially traumatic event may take time. As a result, our study addresses only the immediate response to these sorts of traumatic events.

The second potential limitation is that the present study did not examine whether other types of trauma exposure may have influenced these results (e.g., participants may have experienced other traumatic events in the past). The third potential limitation is that the present study was limited to a relatively small sample of women. Although our sample was large enough to adequately test the present hypotheses, it would be helpful for future studies to involve much larger and more diverse samples. This sort of diversity is important because individuals may respond quite differently to these sorts of events (e.g., men and women have been found to respond differently to traumatic events; Neria et al., 2008). For example, it is possible that Israeli men may have different rates of trauma exposure and different perspectives on the exposure itself, which may result in different associations between sources of resilience and acute symptoms for men and women (e.g., would the present relationship between social support and positive outcomes that was observed for Israeli women also emerge for Israeli men?).

The fourth potential limitation is that the causal relationships between the variables in this study cannot be unequivocally established due to the correlational nature of the study, which prevents us from determining whether intrapersonal and interpersonal sources of resilience played a causal role in protecting women from acute anxiety symptoms after traumatic experiences. For example, it is possible that acute anxiety symptoms after exposure to potentially life-threatening events may have actually influenced perceptions of intrapersonal and interpersonal sources of resilience. Future studies may consider using prospective longitudinal designs that follow individuals who are at especially high risk for experiencing traumatic events over extended periods of time to allow us to gain a better understanding of the associations between sources of resilience and responses to traumatic events.

The fifth potential limitation was our reliance on a snowball technique to recruit participants using Internet-based social media outlets. This sampling method may have increased the likelihood of sampling bias because participants were recruited by their friends who had been made aware of this research. That is, individuals who do not have an active social network or do not

regularly use social media outlets may have been less likely to be recruited for the present study. This sort of sampling bias may have influenced the results of the study by failing to include certain participants. The limitations associated with this recruitment strategy were considered to be an acceptable trade-off given that the goal of the study was to rapidly recruit participants who were currently experiencing this severe threat. Future studies may benefit from using other recruitment strategies such as randomly sampling from regions under severe threat for this sort of traumatic event.

The sixth potential limitation of the present study was that we assessed reactions to acute trauma using PTSD symptoms rather than acute stress symptoms. It would be beneficial if future studies concerning the responses of civilians to potentially traumatic events during war assessed acute stress and PTSD symptoms.

Despite these limitations, the results of the present study have a number of theoretical and clinical implications. Ours was a naturalistic study that focused on participants reporting their experiences under *in vivo*, life-threatening conditions so this research investigated a unique phenomenon that may well have significant ecological validity and reduces recollection biases that may influence the results of retrospective studies. These results underscore the importance of clinical evaluations concerning these intrapersonal and interpersonal sources of resilience in the delivery of mental health care and prevention programs that are focused on populations exposed to traumatic events. This is important because these sources of resilience may play important roles in mitigating acute symptoms after exposure to traumatic events.

Moreover, these results provide additional support for the idea that clinicians should view these sources of resilience as valuable and powerful resources for individuals who have experienced trauma. Trauma care and prevention programs that attempt to improve either intrapersonal or interpersonal sources of resilience (e.g., training individuals to be more optimistic and providing social support) may be especially beneficial in improving psychological adjustment in the wake of traumatic events. For example, mental health practitioners should consider developing social support programs—as well as improving perceptions of social support among individuals exposed to war trauma—in line with recent recommendations for crisis intervention programs that take into account the fact that the posttrauma environment has an important influence on recovery and urge that social support should be facilitated (e.g., Litz, Gray, Bryant, & Adler, 2002). Thus, prevention and intervention programs should be aimed at facilitating intrapersonal and interpersonal sources of resilience in an effort to limit the negative effects of exposure to potentially life-threatening events.

Finally, the application of hope theory to the treatment of PTSD may be important given that patients suffering from traumatic stress often report a profound sense of hopelessness when they enter treatment (e.g., Glass, Flory, Hankin, Kloos, & Turecki, 2009). Other studies that have examined hope in the context of psychotherapy have found that levels of hope are positively associated with treatment gains (Cheavens, Feldman, Woodward, & Snyder, 2006). Although it is conceivable that hope may be one nontargeted change mechanism in manualized cognitive-behavioral treatments of PTSD symptoms and associated outcomes (such as depression), it remains unclear if this is actually the case and it remains an open empirical question.

The significant association between intrapersonal and interpersonal sources of resilience suggests these constructs may be interdependent and enhancement of one may contribute to the enhancement of the other. For example, an individual who feels that there are supportive people in his or her social environment may develop a sense of hope for the future. The mutual enhancement of these intrapersonal and interpersonal sources of resilience may contribute to the restoration of health-sustaining beliefs that may have been shattered by traumatic experiences. Taken together, the present findings point to the important roles that intrapersonal and interpersonal sources of resilience play in mental health outcomes after exposure to potentially traumatic events such as war.

## References

- Affleck, G., & Tennen, H. (1996). Construing benefits from adversity: Adaptational significance and dispositional underpinnings. *Journal of Personality, 64*, 899–922.

- Ai, A. L., Evans-Campbell, T., Santangelo, L. K., & Cascio, T. (2006). The traumatic impact of the September 11, 2001, terrorist attacks and the potential protection of optimism. *Journal of Interpersonal Violence, 21*, 689–700. doi:10.1177/0886-260506287245
- Arbuckle, J. L. (2009). AMOS: A structural equation modeling program. Chicago, IL: SmallWaters.
- Baumeister, R. F., Campbell, J. D., Krueger, J. I., & Vohs, K. D. (2003). Does high self-esteem cause better performance, interpersonal success, happiness, or healthier lifestyles? *Psychological Science in the Public Interest, 4*, 1–44. doi:10.1111/1529-1006.01431
- Baumgardner, A. H. (1991). To know oneself is to like oneself: Self-certainty and self-affect. *Journal of Personality and Social Psychology, 58*, 1062–1072. doi:10.1037/0022-3514.58.6.1062
- Bernstein, E. M., & Putnam, F. W. (1986). Development, reliability, and validity of a dissociation scale. *Journal of Nervous and Mental Disease, 174*, 727–735. doi:10.1097/00005053-198612000-00004
- Besser, A., & Zeigler-Hill, V. (in press). Positive personality features and stress among first-year university students: Implications for psychological distress and self-esteem. *Self and Identity*. doi:10.1080/15298868.2012.736690
- Besser, A., Zeigler-Hill, V., Pincus, A. L., & Neria, Y. (2013). Pathological narcissism and acute anxiety symptoms: A study of Israeli civilians exposed to war trauma. *Psychiatry: Interpersonal and Biological Processes, 76*, 381–197. doi:10.1521/psyc.2013.76.4.381
- Blascovich, J., & Tomaka, J. (1991). Measures of self-esteem. In J. Robinson, P. Shaver, & L. Wrightsman (Eds.), *Measures of personality and social psychological attitudes* (pp. 161–194). New York, NY: Academic Press.
- Boscarino, J. A., Adams, R. E., & Figley, C. R. (2004). Mental health service use 1 year after the World Trade Center disaster: Implications for mental health care. *General Hospital Psychiatry, 26*, 346–358. doi:10.1016/j.genhosppsych.2004.05.001
- Brewin, C. R., Andrews, B., & Valentine, J. D. (2000). Meta-analysis of risk factors for posttraumatic stress disorder in trauma-exposed adults. *Journal of Consulting and Clinical Psychology, 68*, 748–766. doi:10.1037//0022-006X.68.5.748
- Campbell, J. D., Chew, B., & Scratchley, L. S. (1991). Cognitive and emotional reactions to daily events: The effects of self-esteem and self-complexity. *Journal of Personality, 59*, 473–505. doi:10.1111/j.1467-6494.1991.tb00257.x
- Canty-Mitchell, J., & Zimet, G. D. (2000). Psychometric properties of the multidimensional scale of perceived social support in urban adolescents. *American Journal of Community Psychology, 28*, 391–400.
- Carver, C. S., Scheier, M. F., & Segerstrom, S. C. (2010). Optimism. *Clinical Psychology Review, 30*, 879–889. doi:10.1016/j.cpr.2010.01.006
- Cheavens, J. S., Feldman, D. B., Woodward, J. T., & Snyder, C. R. (2006). Hope in cognitive psychotherapies: On working with client's strengths. *Journal of Cognitive Psychotherapy: An International Quarterly, 20*, 135–145.
- Dolbier, C. L., & Steinhart, M. A. (2000). The development and validation of the Sense of Support Scale. *Behavioral Medicine, 25*, 169–179. doi:10.1080/08964280009595746
- Folkman, S. (2010). Stress, coping, and hope. *Psychooncology, 19*, 901–908. doi:10.1002/pon.1836
- Fredrickson, B. L. (2001). The role of positive emotions in positive psychology. *American Psychologist, 56*, 218–226. doi:10.1037//0003-066X.56.3.218
- Gilman, R., Schumm, J. A., & Chard, K. M. (2012). Hope as a change mechanism in the treatment of posttraumatic stress disorder. *Psychological Trauma: Theory, Research, Practice, and Policy, 4*, 270–277. doi:10.1037/a0024252
- Glass, K., Flory, K., Hankin, B. L., Kloos, B., & Turecki, G. (2009). Are coping strategies, social support, and hope associated with psychological distress among Hurricane Katrina survivors? *Journal of Social and Clinical Psychology, 28*, 779–795. doi:10.1521/jscp.2009.28.6.779
- Ho, S. M. Y., Ho, J. W. C., Bonanno, G. A., Chu, A. T. W., & Chan, M. S. (2010). Hopefulness predicts resilience after hereditary colorectal cancer genetic testing: A prospective outcome trajectories study. *BMC Cancer, 10*, 2–10. doi:10.1186/1471-2407-10-279
- Hoffman, Y., Diamond, G. M., & Lipsitz, J. (2011). The challenge of estimating PTSD prevalence in the context of ongoing trauma: Israel during the second intifada. *Journal of Anxiety Disorders, 25*, 788–793. doi:10.1016/j.janxdis.2011.03.016
- Hokanson, J. E., Rubert, M. P., Welker, R. A., Hollander, G. R., & Hedeon, C. (1989). Interpersonal concomitants and antecedents of depression among college students. *Journal of Abnormal Psychology, 98*, 209–217. doi:10.1037//0021-843X.98.3.209

- Hoyle, R. H., & Smith, G. T. (1994). Formulating clinical research hypotheses as structural equation models: A conceptual overview. *Journal of Consulting and Clinical Psychology, 62*, 429–440. doi:10.1037//0022-006X.62.3.429
- Hu, L., & Bentler, P. M. (1999). Cutoff criteria for fit indexes in covariance structure analysis: Conventional criteria versus new alternatives. *Structural Equation Modeling, 6*, 1–55. doi:10.1080/10705519909540118
- Kashdan, T. B., Uswatte, M. F., Steger, M. F., & Julian, T. (2006). Fragile self-esteem and affective instability in posttraumatic stress disorder. *Behavior Research and Therapy, 44*, 1609–1619. doi:10.1016/j.brat.2005.12.003
- Kasler, J., Dahan, J., & Elias, M. J. (2008). The relationship between sense of hope, family support and post-traumatic stress disorder among children: The case of young victims of rocket attacks in Israel. *Vulnerable Children and Youth Studies, 3*, 182–191. doi:10.1080/17450120802282876
- Kelloway, E. K. (1998). Using LISREL for structural equation modeling: A researcher's guide. Newbury Park, CA: Sage.
- Kivimäki, M., Vahtera, J., Elovainio, M., Helenius, H., Singh-Manoux, A., & Pentti, J. (2005). Optimism and pessimism as predictors of change in health after death or onset of severe illness in family. *Health Psychology, 24*, 413–421. doi:10.1037/0278-6133.24.4.413
- Kwon, P. (2002). Hope, defense mechanisms, and adjustment: Implications for false hope and defensiveness hopeless. *Journal of Personality, 70*, 207–231.
- Litz, B., Gray, M., Bryant, R., & Adler, A. (2002). Early intervention for trauma: Current status and future directions. *Clinical Psychology, 9*, 112–134. doi:10.1093/clipsy.9.2.112
- Magaletta, P. R., & Oliver, J. M. (1999). The hope construct, will and ways: Their relations with self-efficacy, optimism and general well-being. *Journal of Clinical Psychology, 55*, 539–551. doi:10.1002/(SICI)1097-4679(199905)55:5<539::AID-JCLP2>3.3.CO;2-7
- Neria, Y., Nandi, A., & Galea, S. (2008). Posttraumatic stress disorder following disasters: A systematic review. *Psychological Medicine, 38*, 467–480. doi:10.1017/S0033291707001353
- Norris, F. H., Friedman, M. J., Watson, P. J., Byrne, C. M., Diaz, E., & Kaniasty, K. (2002). 60,000 disaster victims speak: Part I. An empirical review of the empirical literature, 1981–2001. *Psychiatry, 65*, 207–239. doi:10.1521/psyc.65.3.207.20173
- Norris, F. H., & Kaniasty, K. (1996). Received and perceived social support in times of stress: A test of the social support deterioration deterrence model. *Journal of Personality and Social Psychology, 71*, 498–511. doi:10.1037//0022-3514.71.3.498
- Ozer, E. J., Best, S. S., Lipsey, T. L., & Weiss, D. S. (2003). Predictors of posttraumatic stress disorder and symptoms in adults: A meta-analysis. *Psychological Bulletin, 129*, 52–73. doi:10.1037//0033-2909.129.1.52
- Prati, G., & Pietrantonio, L. (2009). Optimism, social support, and coping strategies as factors contributing to posttraumatic growth: A meta-analysis. *Journal of Loss and Trauma, 14*, 364–388. doi:10.1080/15325020902724271
- Rosenberg, M. (1965). *Society and the adolescent self-image*. Princeton, NJ: Princeton University Press.
- Russell, D., & Cutrona, C. E. (1991). Social support, stress, and depressive symptoms among the elderly: Test of a process model. *Psychology and Aging, 6*, 190–201. doi:10.1037//0882-7974.6.2.190
- Samoon, A., Feder, A., Lee, E. J., Wang, Y., Southwick, S. M., & Schlackman, E. (2010). Earthquake impact in a remote South Asian population: Psychosocial factors and posttraumatic symptoms. *Journal of Traumatic Stress, 23*, 408–412.
- Scheier, M. F., Carver, C. S., & Bridges, M. W. (1994). Distinguishing optimism from neuroticism (and trait anxiety, self-mastery, and self-esteem): A reevaluation of the Life Orientation Test. *Journal of Personality and Social Psychology, 67*, 1063–1078. doi:10.1037/0022-3514.67.6.1063
- Shalev, A. Y., Tuval, R., Frenkiel-Fishman, S., Hadar, H., & Eth, S. (2006). Psychological responses to continuous terror: A study of two communities in Israel. *American Journal of Psychiatry, 163*, 667–673. doi:10.1176/appi.ajp.163.4.667
- Snyder, C. R., Rand, K. L., & Sigmon, D. R. (2002). Hope theory. In C. R. Snyder & S. J. Lopez (Eds.), *Handbook of positive psychology* (pp. 257–276). New York, NY: Oxford University Press.
- Snyder, S. T., Harris, C., Anderson, J. R., Holleran, S. A., Irving, L. M., & Sigmon, S. T. (1991). The will and the ways: Development and validation of an individual-differences measure of hope. *Journal of Personality and Social Psychology, 60*, 570–585. doi:10.1037/0022-3514.60.4.570
- Taylor, S. E., Kemeny, M. E., Reed, G. M., Bower, J. E., & Gruenewald, T. L. (2000). Psychological resources, positive illusions, and health. *American Psychologist, 55*, 99–109. doi:10.1521/jscp.1998.8.2.114

- Thomas, J. T., Britt, T. W., Odle-Dusseau, H., & Bliese, P. D. (2011). Dispositional optimism buffers combat veterans from the negative effects of warzone stress on mental health symptoms and work impairment. *Journal of Clinical Psychology, 67*, 866–880. doi:10.1002/jclp.20809
- Van Duijl, M., Nijenhuis, E., Komproe, I. H., Gemaat, H. B. P. E., & de Jong, T. (2010). Dissociative symptoms and reported trauma among patients with spirit possession and matched healthy controls in Uganda. *Culture, Medicine, and Psychiatry, 34*, 380–400. doi:10.1007/s11013-010-9171-1
- Weathers, F. W., & Ford, J. (1996). Psychometric properties of the PTSD checklist (PCL-C, PCL-S, PCL-M, PCL-PR). In B. H. Stamm (Ed.), *Measurement of stress, trauma, and adaptation*. Lutherville, MD: Sidran Press.
- Weinberg, M., Besser, A., Campeas, M., Shvil, E., & Neria, Y. (2012). Civilians exposed to terrorism and war trauma in Israel: The role of intra- and inter-personal factors. In A. M. Columbus (Ed.), *Advances in psychology research* (Vol. 94, pp. 1–53). Hauppauge, New York: Nova Science Press.
- Weinberg, M., Besser, A., Zeigler-Hill, V., & Neria, Y. (in press). Dispositional optimism and self-esteem as competing predictors of acute symptoms of GAD and dissociative experiences among civilians exposed to war trauma. *Psychological Trauma: Theory, Research, Practice, and Policy*.
- Zimet, G. D., Dahlem, N. W., Zimet, S. G., & Farley, G. K. (1988). The multidimensional scale of perceived social support. *Journal of Personality Assessment, 52*, 30–41. doi:10.1207/s15327752jpa5201\_2
- Zucker, M., Spinazzola, J., Blaustein, M., & Van der Kolk, B. A. (2006). Dissociative symptomatology in Posttraumatic Stress Disorder and disorders of extreme stress. *Journal of Trauma & Dissociation, 7*, 19–31. doi:10.1300/J229v07n01\_03