

Adaptive time-domain filtering for real-time spectral discrimination in a Michelson interferometer

Sameer R. Bhalotra, Helen L. Kung, Yang Jiao, and David A. B. Miller

Edward L. Ginzton Laboratory, Stanford University, Stanford, California 94305-4085

Received February 8, 2002

We present a method of spectral discrimination that employs time-domain processing instead of the typical frequency-domain analysis and implement the method in a Michelson interferometer with a nonlinear mirror scan. The technique yields one analog output value per scan instead of a complete interferogram by directly filtering a measured scan with a reference function in the time domain. Such a procedure drastically reduces data-processing requirements downstream. Additionally, using prerecorded interferograms as references eliminates the need to compensate for scan nonlinearities, which broadens the field of usable components for implementation in miniaturized sensing systems. With our efficient use of known spectral signatures, we demonstrate real-time discrimination of 633- and 663-nm laser sources with a mirror scan length of $1 \mu\text{m}$, compared with the Rayleigh criterion of $7 \mu\text{m}$. © 2002 Optical Society of America

OCIS codes: 300.6190, 300.6300, 350.5730.

In recent years there has been a dramatic increase in the generation, transmission, storage, and processing of hyperspectral imagery in sensing applications by use of a variety of optical systems including grating, prism, and Fourier-transform spectrometers.¹ Such imagery can be a rich source of detailed spectral information that is useful in chemical analysis, materials characterization, and target identification. The challenge of processing the large volumes of information has motivated the development of new methods for handling data. There have been attempts at advanced data compression with and without loss,² data processing by use of neural network concepts,³ interferogram analysis in Fourier-transform infrared systems,^{4,5} Hadamard encoding with a micromirror array,⁶ and processing in the optical domain.⁷ These methods can potentially solve problems of great size and complexity. However, most of these techniques require significant data-processing power and careful sensing-system characterization and may not be rapidly adaptable to new sensing tasks.

For applications in which a sensing system is needed for distinguishing one spectrum from the background or from a set of known spectra, we propose implementation of direct time-domain filtering of interferograms in a simple interferometer. Using this method, we demonstrate real-time spectral discrimination without digital processing in a Michelson interferometer with a nonlinear mirror scan. Linear transforms for converting data to the frequency domain are unnecessary when this technique is used, and characterization and compensation for nonlinearities in the spectrometer scan are also avoided.

Furthermore, one can readily adapt the system to sense different spectra merely by changing the time-domain references that serve as filters. Efficient utilization of these known signatures drastically reduces information collection requirements. In general, this direct processing method can be applied to signals generated in any domain (e.g., time, space, and frequency), obviating the necessity to perform

transforms between domains. These advantages allow simple spectrometers^{8,9} to perform sophisticated sensing and identification tasks with minimal data-processing power.

One way to identify a measured spectrum with a set of reference spectra is to calculate and compare overlap integrals of the measured spectrum with the references. The process reduces to multiplication and integration and can also be viewed as taking an inner product of the spectral signal and a reference. Such analysis is typically done in the frequency domain, but here we suggest obtaining a simple inner product in the time domain (Fig. 1). This value is easily calculated, given a sensing system that reports spectral information in the form of a time-domain signal.

Reference functions can be directly constructed in the time domain electronically. For simple discrimination tasks the references can be unprocessed interference functions that have been recorded from known sources. In other situations the interference functions

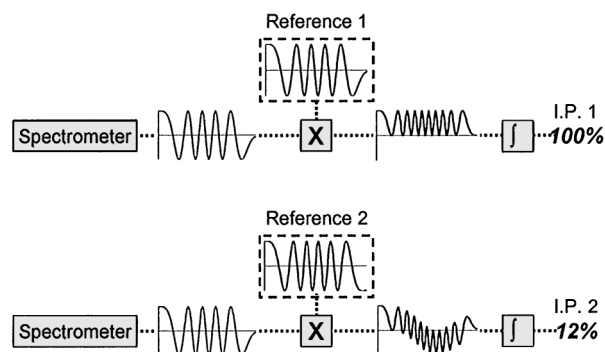

Fig. 1. Time-domain output from a spectrometer (e.g., an interference function from a Michelson spectrometer) multiplied by a time-domain reference function recorded from a light source of interest and integrated over the time of one spectrometer scan (e.g., one mirror scan). This process is repeated with a second reference that corresponds to a second light source. Comparison of the resultant inner products (I.P.1, I.P.2) identifies the observed light source.

may be inputs to a mathematical algorithm that creates a new set of time-domain filter functions particularly suited to the discrimination task. Regardless of their complexity, obtaining the reference functions is at most a one-time task; once it is performed, one can use the set of references repeatedly to directly analyze measured interferograms. With our method there is no required Fourier transform or digital processing downstream. Also, one can reprogram a system to analyze different spectra by simply recording a new set of reference functions. This procedure permits rapid adaptability to new sensing tasks and provides greater flexibility to use nonlinear scanning components in sensing systems.

One typically handles nonlinear mirror scans by sampling interferograms in steps of equal optical path difference measured by a reference laser system¹⁰ or by sampling in equal time intervals and digitally compensating for premapped nonlinear motion. However, if references sampled in equal time intervals are recorded with the same system that had been used to test unknown interferograms, the effects of any nonlinearities in the mirror scan motion will be accounted for, and compensation will be unnecessary. This process simplifies the sensing system and yields considerable freedom to utilize components that lack linear scan motions, such as high-speed, harmonically oscillating microelectromechanical scanning mirrors.⁸ Because measurement rate is proportional to mirror scan rate, miniature mirrors can offer rapid spectral analysis.

We have used the time-domain inner product method to demonstrate real-time discrimination of two laser sources. The optical setup is a Michelson interferometer with a 2.5-cm-diameter fixed mirror, a 4 mm × 4 mm square mirror upon a piezoelectric transducer (PZT), and a silicon photodetector. The two sources are a 633-nm He-Ne laser at 281 μW and a 663-nm laser diode at 328 μW, both with a FWHM beam size of 1.5 mm. To test the filtering method with nonlinear mirror motion we drive the PZT with a dc-offset sinusoid at 0.1 Hz.

We have constructed a system that performs both reference function recording and inner product calculations and synchronizes the mirror scans as well (Fig. 2). Photodetector output flows directly to a computer-controlled electronic circuit. The control system can send the measured interference function either to a data-acquisition interface for recording or to a simple circuit for inner product calculation. In the latter case the time-varying interference function is multiplied by an unprocessed, prerecorded reference function, and the product is integrated over one mirror scan. The multiplication is performed in an analog multiplier integrated circuit, and the integration is performed in an operational-amplifier circuit. Here the interference functions have equal magnitudes; however, for the general case of interference functions with unequal magnitudes we would also require an electronic circuit for normalization of the inner product. Data processing is complete as soon as the interferometer finishes scanning; only the final inner product value is transmitted for data acquisition by

the computer. This reduces the information handling to just one analog electronic value per scan.

For the system described here, one can derive time-domain interference functions theoretically by combining the standard sinusoidal interferogram with the mirror motion function. Output photocurrent I is

$$I(t) = \frac{A}{2} \left(1 + \cos \left\{ \frac{2\pi d}{\lambda} [1 - \cos(2\pi f t)] + \epsilon \right\} \right), \quad (1)$$

where t is time, A is the maximum current, d is the mirror scan length, λ is the source wavelength, f is the mirror scan frequency, and ϵ is a phase offset accounting for mirror scans starting away from the point of zero optical path difference. For one mirror scan, $I(t)$ is evaluated for $t = 0$ to $1/(2f)$.

With the 633-nm source coupled into the interferometer, theoretical inner products with 633-nm (upper curves) and 663-nm (lower curves) reference functions are plotted as the thinner curves in Fig. 3. Real-time experimental data, with all processing done in an analog electronic circuit in the time domain, are plotted as thicker curves. The lower and upper curves are well separated at high scan lengths, and the separation generally decreases with decreasing scan length. Where

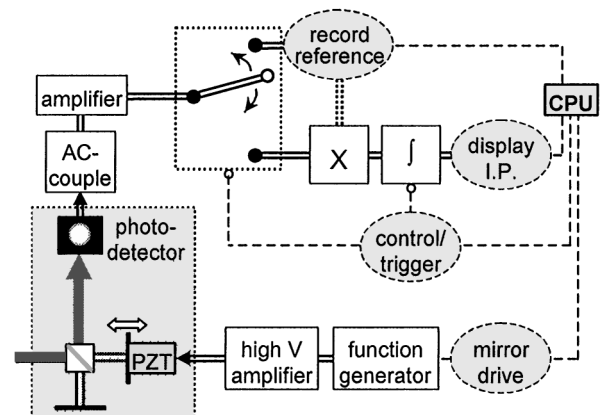

Fig. 2. Photocurrent from the Michelson interferometer either recorded as a reference function or routed to the inner product (I.P.) electronic circuit in real time.

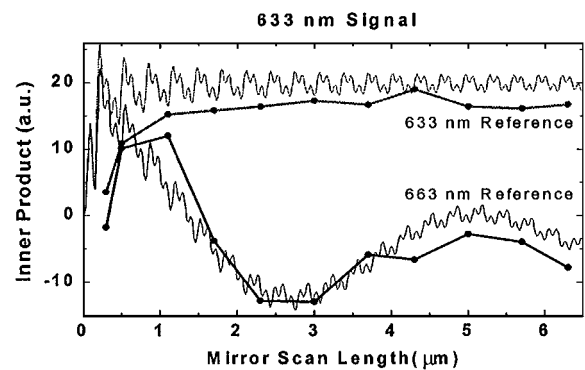

Fig. 3. Inner products of a 633-nm signal with a 633-nm (the two upper curves) and a 663-nm (the two lower curves) reference. Thicker curves, real-time inner products calculated in the electronic circuit. Thinner curves, theoretical simulations; the small oscillations are due to high-frequency sinusoidal components from the inner products of interference functions described in Eq. (1).

the upper inner product is measurably greater than the lower, discrimination is straightforward. The decline in experimental inner product values relative to theory for scan lengths of $<1 \mu\text{m}$ is due to inconsistent PZT motion in this regime.

Discrimination of known spectra can require much less information collection than a general measurement of an unknown spectrum. For the Michelson interferometer, this fact is manifested by a reduction in the required optical path difference. Thus it is possible to discriminate the two sources at mirror scan lengths that are significantly lower than those suggested by the spectrometer system's nominal resolution. For discriminating 633- and 663-nm wavelengths, the Rayleigh resolution criterion suggests a scan length of $7.0 \mu\text{m}$. The system presented here is able to choose the correct source with nearly 100% accuracy for a $2\text{-}\mu\text{m}$ scan length, where the inner-product curves are widely separated. At $1 \mu\text{m}$ the margin for error is decreased; vibrations and mirror scan variations, which lead to uncertainties in inner product values, are more likely to cause errors in discrimination. Nevertheless, accuracy is measured to be greater than 90% at $1 \mu\text{m}$. Along with the decrease in required mirror displacement, the shorter required scan length can reduce requirements for mirror actuator size, mirror actuator power, and frequency response of the photodetector and electronics. Such a benefit could permit the implementation of simpler components, including microelectromechanical mirror actuators, which would be valuable in the design of miniaturized spectrometers.

It is straightforward to extend our method to more-complex discrimination tasks. For example, the difference between two reference functions can be implemented as a new reference. In the presence of either one of the two sources that generated the original reference functions, the inner product yields a relatively high absolute value. However, the presence of both sources results in a low absolute value. In this way, additional logical data processing can be accomplished without additional real-time calculations.

In conclusion, time-domain filtering permits the efficient implementation of simple, adaptive spectrometers tasked with discriminating known spectra. Reduction in required mirror displacement and

insensitivity to nonlinear mirror scanning can dramatically relax operating requirements. Inherent programmability and output of one inner product value, compared with the large data set needed for a full spectral analysis, can provide processing flexibility and real-time results without digital calculations. For example, the single-value output can drive a simple discriminator for identifying targets in background clutter or detecting outliers in production quality monitoring. Adapting to a new sensing task requires only recording a new set of interferograms and, at worst, a one-time recalculation of time-domain reference functions. Systems that use this technique may facilitate fast, flexible information analysis that is especially suitable for field-deployable systems, personal-use medical devices, and other compact sensor systems that are now in development.

This research was supported by U.S. Air Force contract F49620-00-C-0040 and Defense Advanced Research Projects Agency grant PWASSP. S. R. Bhalotra and Y. Jiao gratefully acknowledge support of a Regina Casper Stanford Graduate Fellowship, a Reed-Hodgson Stanford Graduate Fellowship, and the National Science Foundation. S. R. Bhalotra's e-mail address is bhalotra@stanford.edu.

References

1. N. Gat, *Proc. SPIE* **4056**, 50 (2000).
2. K. Sayood, *Geosci. Remote Sens. Newsl.* **84**, 7 (1992).
3. D. S. Kimes and R. F. Nelson, *Intl. J. Remote Sens.* **19**, 2639 (1998).
4. R. E. Shaffer and R. J. Combs, *Appl. Spectrosc.* **55**, 1404 (2001).
5. A. S. Bangalore, G. W. Small, R. J. Combs, R. B. Knapp, R. T. Kroutil, C. A. Traynor, and J. D. Ko, *Anal. Chem.* **69**, 118 (1997).
6. R. A. DeVerse, R. M. Hammaker, and W. G. Fateley, *Appl. Spectrosc.* **54**, 1751 (2000).
7. P. I. Shnitser, I. P. Agurok, S. Sandomirsky, and A. Avakian, *Proc. SPIE* **3717**, 185 (1994).
8. O. Manzardo, H. P. Herzig, C. R. Marxer, and N. F. de Rooij, *Opt. Lett.* **24**, 1705 (1999).
9. H. L. Kung, S. R. Bhalotra, J. D. Mansell, D. A. B. Miller, and J. S. Harris, Jr., *IEEE J. Sel. Top. Quantum Electron.* **8**, 98 (2002).
10. P. Haschberger, *Appl. Spectrosc.* **48**, 307 (1994).