

Addition of trace metals and vitamins for the optimisation of a pulp and paper mill activated sludge wastewater treatment plant.

JASON BARNETT^{1*}, DES RICHARDSON², KAREN STACK¹, TREVOR LEWIS¹

¹School of Chemistry
University of Tasmania

²Norske Skog Paper Mills (Australia) Ltd
Boyer

*Corresponding author (Jason.Barnett@utas.edu.au or Trevor.Lewis@utas.edu.au)

SUMMARY

Generally, industrial wastewater does not contain sufficient micronutrients to support optimal bacterial growth as a number of micronutrients are essential for biological cell function and activated sludge stability. A laboratory scale activated sludge process using porous pots with a capacity of 4.5 L has been used to mimic the operation of an activated sludge plant. Water soluble B group vitamins and trace metals including calcium, cobalt, copper, iron, magnesium, molybdenum and zinc were chosen for the micronutrient addition trials. The results indicated that COD removal was significantly improved by 7 to 12% compared to a control by the addition of calcium, cobalt, copper, iron and magnesium.

KEYWORDS:

Micro-nutrients, activated sludge, wastewater treatment, porous pots, trace elements

INTRODUCTION

In January 2008 Norske Skog, Boyer, Tasmania, commissioned an Activated Sludge (AS) wastewater treatment plant to lower the chemical oxygen demand (COD) and suspended solids (SS) in the mill effluent before discharge into the Derwent River. Microorganisms convert the organic matter into simple end products such as CO₂ and additional biomass. The biomass is then separated by gravity in a settling stage. AS wastewater treatment is not new for the treatment of pulp and paper effluent and similar plants operate throughout the world (1). The plant is similar in design to a municipal sewage treatment plant, though the influent has high wood fibre levels, with low nutrient levels. There is significant variability in the wastewater between pulp and paper mills, depending on the operating conditions and feed-stock of the plant. Wastewater variability within a pulp and paper mill affects the efficiency of the biological treatment, and this can be reflected in the degree to which organic material is removed. Effective AS treatment requires a stable controlled environment; controlling factors include pH, temperature, nutrient levels, DO concentration and mixing (2, 3). Insufficient micronutrients in the wastewater can affect the microbiological balance, and may cause instability in the AS process (1, 4-6). Due to the low levels of macronutrients in the influent, the biological communities need other chemical inputs to operate effectively. The most notable chemical inputs at Boyer are nitrogen and phosphorous which are added into the secondary effluent treatment plant (SETP). Most industrial effluents do not contain sufficient micronutrients in the form of either trace metals or water-soluble B-group vitamins to sustain the microbial growth and diversity needed for activated sludge plants (4, 7, 8). The aim of adding micronutrients to the SETP

is to increase the COD removal through greater microorganism activity.

For optimal diversity of microorganisms in activated sludge an extensive range of micronutrients are essential. In a system with limiting micronutrients, bacterial populations are dominated by species which are best adapted for the limiting conditions (9). Of the factors which influence the operation of the AS treatment plant, micronutrients present the best prospects for enhancement of the process (10). For optimal reduction of organic carbon it is essential to make the system carbon limited not macro- or micronutrient limited (3). Microorganisms incorporate approximately 60% of available organic matter for growth, measured as mixed liquor suspended solids. This process works most efficiently if N, P and micronutrients are not limiting (11).

TRACE METAL ADDITION

For sustainable growth and reproduction in AS wastewater treatment plant bacteria need an energy source, carbon and inorganic macronutrients (N, P and K) (2, 4, 12) and micronutrients (Ca, Mg, Fe, Zn, Mn, Mo, Se, Co, Cu and Ni) (2-4, 12). Primary clarifier liquor grab samples were analysed to determine the micronutrients of most interest for further investigation. The level at which microbial growth is stimulated or inhibited by the addition of micronutrients is, in part, dependent on the concentration that is bioavailable in the treatment system (13). This is particularly difficult for a number of trace metals that form insoluble salts with other essential nutrients, such as Fe(PO₄) and Ca₃(PO₄)₂, making them unavailable (3). Micronutrients are generally required at concentrations below 1 mg/L for enzyme production and cell growth (9, 12, 14). On the other hand, some of the trace metals, such as, though not limited to, Zn and Cu, which are required to support microbial life in an AS treatment plant, are toxic at higher concentrations. Consideration must be given to the concentrations of heavy metals discharged in the effluent and their concentration in the sludge, especially when it is to be used as a soil conditioner.

Additions of micronutrients Zn, Cu and Co to AS treatment plants at trace quantities have been reported to stimulate microbial growth (15). Mo is also a common limiting nutrient in pulp and paper mill wastewater (16), while in a textile AS plant the addition of 2.0 mg/L Mo has increased COD removal rates by a factor of 1.4 (17).

Co is an enzyme activator and involved in the synthesis of Vitamin B₁₂. The reported optimum concentration of cobalt in municipal activated sludge has been estimated at 0.02 – 0.05 mg/L (15). The addition of < 1.0 mg/L Co to municipal AS plants has been reported to be beneficial (9). Dosing Co at concentrations between 0.01 and 0.1 mg/L to a sewage treatment plant has been beneficial to effluent quality and the addition of 1.0 mg/L Co increased the production of Vitamin B₁₂ by 50% (3). There are contradictory reports however of cobalt inhibition and stimulation (15).

VITAMIN ADDITION

Most vitamins function as components of coenzymes and are the most commonly required growth factors for bacteria (12). A healthy mixed culture of bacteria in the AS can provide most of the required vitamins, however, industrial AS has a lower diversity and may benefit from an addition of vitamins (9, 12, 18, 19). There are limited reports on the effects of vitamin addition to industrial AS treatment plants especially for the pulp and paper industry. The concentration and dependence of each vitamin varies. Experimentation on industrial AS treatment plants has shown that micronutrient supplementation significantly alters the microbial diversity (6).

Table 1 summarizes the estimated requirements for various trace metals and soluble B vitamins reported in the literature for optimal cell growth in a wastewater treatment plant.

Nutrient B-Vitamins	Estimated Micronutrient Requirements [mg/L] ^(4, 9, 20, 21)	Nutrient Trace Elements	Estimated Trace Element Requirements [mg/L] ^(4, 21, 22)
Thiamine (B ₁)	0.3 – 1.2	Calcium (Ca)	3 – 5
Riboflavin (B ₂)	0.5 – 2.0	Cobalt (Co)	0.02 – 0.05
Niacin (B ₃)	0 – 10.0	Copper (Cu)	0.1 – 1.0
Pantothenic acid (B ₅)	0.01 – 2.0	Iron (Fe)	1 – 4
Pyridoxine (B ₆)	0.1 – 10.0	Magnesium (Mg)	3 – 10
Biotin (B ₇)	0.1 – 1.0	Molybdenum (Mo)	0.02 – 0.05
Folic acid (B ₉)	N/A	Zinc (Zn)	0.01 – 1.0
Cobalamine (B ₁₂)	0.005		

Table 1 Estimated requirements for water-soluble B-vitamins and trace metals for optimal cell function in wastewater treatment plants.

Over 300 species of bacteria have been isolated from municipal AS of which 37% had an essential vitamin requirement and a further 20% had growth stimulated by the addition of vitamins (23). An industrial AS plant would be expected to have significantly lower concentrations of vitamins available for cell growth. Of the industrial and municipal sludges studied bacteria isolated from pulp and paper sludge had the highest vitamin requirements (19, 24). Eighty to ninety percent of bacteria isolated from pulp and paper wastewater treatment plants were found to require vitamin B addition for optimal growth (9), with ≥ 99% requiring B₁ for growth (19, 24). The essential vitamins

for growth were found to be B₁, B₃ and B₇ (3, 19). For the best enhancement of bacterial cell enzyme activity a multiple vitamin addition has a greater affect than single vitamin addition .

EXPERIMENTAL

PRELIMINARY METALS ANALYSIS

Samples were collected daily throughout the mill, including four sites within the SETP: activated sludge reactor (ASR), biofilm reactor (BFR), return activated sludge (RAS) and the waste activated sludge (WAS). Sub-samples were taken hourly and combined into a 24 h composite sample. 50 mL aliquots from each sample site were filtered, acidified with HNO₃ (to 1%) and refrigerated until analysis using a GBC XplorAA atomic absorption spectrophotometer to measure metals. Quality control samples were analysed by an external laboratory using inductively coupled plasma mass spectrometry (ICP-MS).

REAGENTS

The macronutrients N and P were sourced as LR grade urea and AR grade orthophosphoric acid, both supplied by BDH. The trace elements for the micronutrient additions were added as solutions of: calcium chloride, ferrous sulphate, magnesium sulphate, sodium molybdate and zinc sulphate (BDH), copper (II) sulphate (Ajax) and cobalt sulphate (M & B Laboratory Chemicals). The B-group vitamins were supplied by Sigma Chemicals.

Reagents used for COD digestion were: potassium dichromate (Ajax), mercury (II) sulphate and AR grade sulphuric acid (Merck), silver sulphate and potassium hydrogen phthalate (BDH). The phosphate buffer reagents for BOD₅ were obtained from BDH and Ajax chemicals. Potassium antimonyl tartrate and potassium molybdate were obtained from M & B Laboratory Chemicals and AJAX Chemicals, respectively. The ascorbic acid was supplied by Sigma Chemicals. The bulk concentrated hypochlorite solution was obtained from Hunters Products, Tasmania.

EQUIPMENT

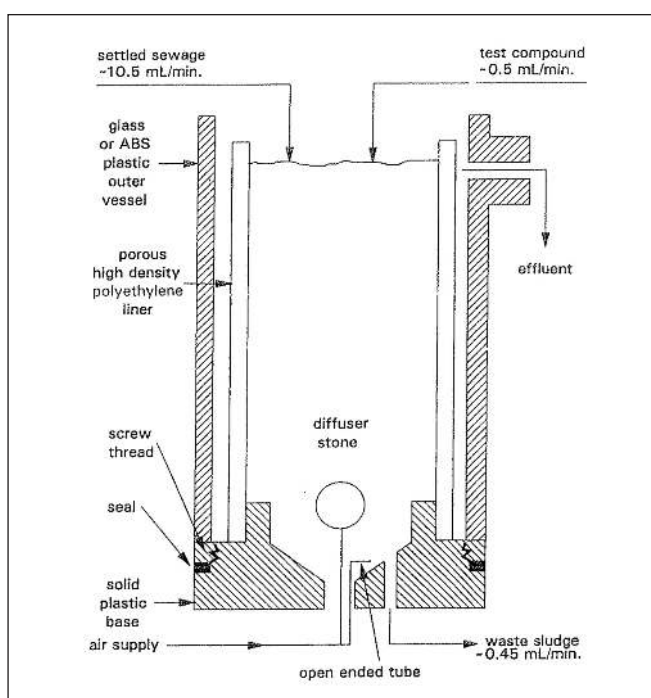

Fig. 1 The schematic of a porous pot. Adapted from the USEPA

The method for reproducing the conditions in an activated sludge reactor was adapted from the USEPA guidelines for simulation test using porous pot (25, 26) (Fig. 1.). The method uses a porous high density polyethylene liner (70 μm , Scientific Commodities Inc, Arizona, USA) as an inner vessel to overcome problems with circulating sludge and avoid the loss of sludge in the effluent (27) (Fig. 2.).

An Elite 802 aquarium air pump with 5 mm open tubing and commercial fish tank aeration stone for aeration and mixing was fitted to each porous pot. Standard 200 W Fluval Tronic aquarium heaters were used in each pot to maintain a temperature of 35°C. Minipuls and Alitea peristaltic pumps were used to supply



Fig. 2 Image of the porous pot experimental set up. From the left: 55 L storage container fitted with a mechanical stirrer; peristaltic pumps to transfer feedstock to the porous pots (top), additive reservoirs (centre) and peristaltic pumps to transfer additives to the porous pots (bottom); six porous pots fitted with waste taps, air tubes and heaters; air pumps.

feed and nutrient solutions with flow rated tygon pump tubing (TACS Australia). The pH was measured using an Orion 420A pH meter, and temperature and DO were measured with an OxyGuard DO probe. A Pharmacia Novaspec II UV-Vis spectrophotometer was used to measure absorbance for the COD, PO_4^{3-} and NH_3 analysis. Advantec GA – 55 glass fibre filters were used to filter suspended solids (SS) and mixed liquor suspended solids (MLSS) samples. The turbidity was analysed using a Hach 2100P turbidimeter.

TRIAL DETAILS

Runs were completed using four 1000 L primary clarifier effluent samples collected from the Boyer SETP on 10th Aug 2010, 4th Oct 2010, 12th Nov 2010 and 5th Jan 2011. The pots were seeded in Launceston on the collection day with 2 L of return AS no more than 3 hr old. The 1000 L bulk samples were decanted into 25 L containers and refrigerated at 4 °C until used. The pilot plant was operated for an initial stabilisation period of 3-4 days allowing the pots to settle and adjustments to be made to flow rates and air supply levels before the trace element additions were started. The run duration was between 21 and 26 days, depending on the number of porous pots employed and flow rate of the feedstock. Only data collected after day 15 was processed to evaluate the results. The temperature was maintained at 35 °C, and the DO level was maintained at ≥ 2.0 mg/L. The full-scale SETP plant operation was replicated by

setting the influent flow rate to give a retention time of 14 h, with a target sludge age and food to mass (F/M) ratio of 5-7 days and 0.28, respectively.

A 55 L container was used to supply the primary treated sample to the pots. The bulk solution was stirred using a Eurostar digital stirrer at 300 rpm and delivered to each pot at 5.4 mL/min. The flow rate for the macro and micronutrients was 2.4 mL/h. Macronutrients N and P were supplied at a ratio of COD:N of 33:1 and N:P of 32:1, which were the levels used in the Boyer SETP at that time. The final concentration of N and P in the pots in each run was approximately 50 mg/L and 1.5 mg/L, respectively. The target residual N and P were 1.0-2.0 mg/L and 0.5-1.0 mg/L, respectively.

The trace elements Ca, Fe and Mg were added to the porous pots from 500 mg/L bulk solutions, the final target concentration in the pots was 4.2 mg/L. Cu and Zn were added from 60 mg/L solutions and Co and Mo from 6 mg/L solutions to reach final target concentrations of 0.5 mg/L and 0.05 mg/L, respectively. The water-soluble vitamins were added to the pots from bulk solutions of 120 mg/L to give a final target concentration of 1 mg/L.

CLEANING

Once per week the contents of each pot were decanted into 5 L beakers to allow the pot to be cleaned. Aeration and macro- and micronutrient additions were continued during the cleaning procedure. A 5:1, water:hypochlorite 20 L bath was made for soaking the empty pots for 2 h. These were then rinsed thoroughly with running water for half an hour.

DATA COLLECTION AND MEASUREMENT DETAILS

The results for temperature, pH, DO and peristaltic pump flow rates were recorded daily, with a WAS sample discarded daily so that a given F/M ratio was maintained. The tests for COD, settleability/MLSS, NH_3 , PO_4^{3-} and SS were undertaken 2 – 3 times per week. In the last two weeks of a run the COD and SS were determined daily. BOD_5 analysis was undertaken weekly. Samples were filtered through a glass fiber filter before COD was determined by the reactor digestion method adapted from the Hach Method 8000. Analysis of BOD_5 was by the APHA standard method (28), where the porous pot effluent was diluted 1:5 and influent was diluted 1:500 with aerated ultra pure water. As SS is measured daily in the full-scale effluent treatment plant, it was important to measure SS during the experimental runs to have comparable results between the two measurements. Initially the SS concentration was quantified by decanting the AS from each pot into 5 L beakers, the solid was allowed to settle for 30 min and 100 mL of clear liquor was pipetted from the top. The 100 mL aliquot was filtered through pre-weighed glass fibre filters, the filter papers and retentate were dried in an air oven and weighed to calculate SS. The sludge was required to settle without aeration or heat for 30 – 45 minutes while the solid settled. To eliminate the risk that this long settling period would affect the porous pot run, turbidity was introduced as a fast and simple surrogate for suspended solids at the beginning of Run 3. The turbidity analysis required a 15 mL sample from settled waste activated sludge (WAS). A relationship $y = 5.09x^{0.55}$ (where x is turbidity and y is SS) was found between turbidity and suspended solids with a calculated $R^2 = 0.82$.

Due to the capacity of the pots a 50 mL sample was collected

from each pot for the sludge volume (SV) and MLSS test. After a settling period of 30 min the SV was recorded in mL/L, the samples were then filtered through glass fibre filter papers, dried and weighed to calculate the MLSS (mg/L). The sludge volume index (SVI) was calculated using $SV/MLSS \times 1000$ (mL/g).

Analysis of PO_4^{3-} was undertaken using the ascorbic acid method according to the APHA standard methods (28). Residual N, as ammonia, was determined by the Salicylate Method using pre-prepared Hach tubes according to Hach method 10205.

RESULTS AND DISCUSSION

PRELIMINARY SURVEY

The long term mean COD removal from Jan 2008 to May 2010 at Boyer was $76 \pm 7\%$ and the mean SS removal was $93 \pm 8\%$. To evaluate trace metal levels in the Boyer effluent, samples were collected between 11th Jan 2010 and 5th Feb 2010, for trace metal analysis. The SETP comprised four sample sites: activated sludge reactor (ASR), biofilm reactor (BFR), return activated sludge (RAS) and waste activated sludge (WAS). Using an ANOVA analysis of means no differences was found in the trace metal concentrations from the SETP liquor samples and the four sample sites. The four sample site results were combined to determine the average trace element concentrations in the SETP plant (Table 2). From the initial analysis it was found that Fe, Cu, Co and Mo concentrations in the SETP liquor were below the accepted microbial trace metal requirements (Table 2). From the results and the literature review the trace metals Ca, Mg, Fe, Cu, Co Mo and Zn were selected for further studies.

The concentrations of trace elements Ca, Mg and Zn were found to be either above or within the accepted limits. The concentrations of Co, Cu, Fe and Mo were below the accepted requirements (Table 2). Through the SETP process the removal of Ca, Co and Mg was limited; however, the removal of Cu, Fe, Mo and Zn was between 20% and 35% (Table 2).

POROUS POT TESTS

To determine if the refrigerated bulk samples were stable over the duration of each porous pot run, the COD of the feedstock was determined daily over the run. For the four 1000 L samples collected from the Norske Skog primary clarifier effluent between August 2010 and January 2011 the mean COD over a run is compared to COD of a 24 hour composite sample collected by Boyer staff on the day the 1000 L bulk sample was collected (Table 3). Two important points are clear from this table. First that, due to the plant operational variability, the COD between collected samples fluctuated considerably. Second, as indicated by the result for Run 2, the single sampling event represented by the collection of the 1000 L bulk sample can be quite different to the result for the 24 hour composite. Such short-term variation

would be smoothed out by taking composite samples over a 24 hour period, which gives the “average” result for that period.

Some variation was observed in the COD removal efficiency of the control samples between the four test runs (Figs. 4 and 5). The variation could be due to the changes in operating conditions in the plant, such as paper grade changes, causing the influent COD to fluctuate. Based on preliminary metal analysis (Table 2) there were no significant variations in the micronutrient levels in the separate bulk effluent samples. Other than Ca and Mg, which were detected in excess, any variation that was in the trace element concentrations was well below the accepted microbial trace element requirements.

Table 3 The average COD for four Boyer primary clarifier samples collected between August 2010 and January 2011. The “Boyer COD Primary Effluent” results are the primary clarifier effluent analysis performed by Boyer staff on the day of bulk sample collection.

Run	Sample Collection Date	Porous Pot Mean COD [mg/L]	Boyer Primary Clarifier Effluent COD [mg/L]	Difference
Run 1	10 Aug 2010	1412 ± 178	1335	5%
Run 2	04 Oct 2010	1687 ± 159	1257	25%
Run 3	08 Nov 2010	1605 ± 104	1511	6%
Run 4	05 Jan 2011	1359 ± 145	1286	5%

Prior to the commencement of the porous pot tests, a preliminary trial run was undertaken with only N and P additions and no trace elements to determine the reproducibility between the various pots. After two weeks there was no significant statistical difference between the COD removal in each of the four pots ($P = 0.883$). The COD removal from the pots was $77 \pm 4\%$, $78 \pm 2\%$, $79 \pm 3\%$ and $78 \pm 4\%$ in comparison the removal at Boyer on the 10th Aug 2010 of 81%. Due to the good agreement between pots in the initial run, the subsequent experimental runs were undertaken with one control pot and a number of trial pots in

order to maximize micronutrient addition trials.

RUN ONE

The effectiveness of trace metal additions was tested over the first two full runs after the preliminary trial. The metals Fe, Ca and Mg were added in Run 1 from separate 500 mg/L bulk solutions to give final concentrations of 4.2 mg/L of one of these metals in each of the porous pots. The mean COD removal in the control pot in Run 1 was $76 \pm 1\%$ (Fig. 1); the mean removal for pots with additions of Fe, Ca or Mg was $83 \pm 4\%$, $83 \pm 4\%$ and $83 \pm 5\%$, respectively, indicating a 7% increase in COD removal for each metal. Using an ANOVA comparison of means a significant statistical difference was found between the control and all metal

Table 2 Mean concentration of selected trace metals [mg/L] in SETP from Boyer.

Metal [mg/L]	Ca	Co	Cu	Fe	Mg	Mo	Zn
Mean Concentration of Combined SETP Samples	18.5	0.003	0.03	0.30	5.4	0.002	0.24
21 Day Sample Period Standard Deviation	8.4	0.001	0.04	0.24	1.5	0.002	0.08
P-Value Between SETP Sample Sites	0.994	0.794	0.717	0.232	0.741	0.105	0.801
Accepted Microbial Trace Element Requirements ^(4, 21)	3 - 5	0.02 - 0.05	0.1 - 1.0	1 - 4	3 - 10	0.02 - 0.05	0.01 - 1.0
SETP Metal removal*	4%	3%	35%	33%	0%	24%	20%

*The removal of metals calculated from the primary clarifier effluent and the secondary clarifier influent

additions: Fe ($P = 0.003$), Ca ($P = 0.001$) and Mg ($P = 0.008$). The initial concentration of Fe in the SETP was 0.38 mg/L, well below the theoretical requirements for optimum bacterial growth (1 to 4 mg/L). As the process of COD removal was not determined, the improvement in COD removal could be due to biological consumption of organic matter or through chelation or precipitation which can also have an effect on the bioavailability of Fe in solution (22). The addition of Ca, Fe and Mg has also been reported to aid in controlling bulking (29), which effects the efficient removal of COD (29, 30). During Run 1 the sludge in the Fe pot became markedly darker from the second day. There was no difference in the odour of this pot compared to the others, indicating the absence of significant levels of H_2S . The addition of 1.0 mg/L Ca has been reported to enhance COD removal from a chemical manufacturing plant (20) and 5.0 mg/L Mg to a textile wastewater has been reported to have doubled COD removal (17).

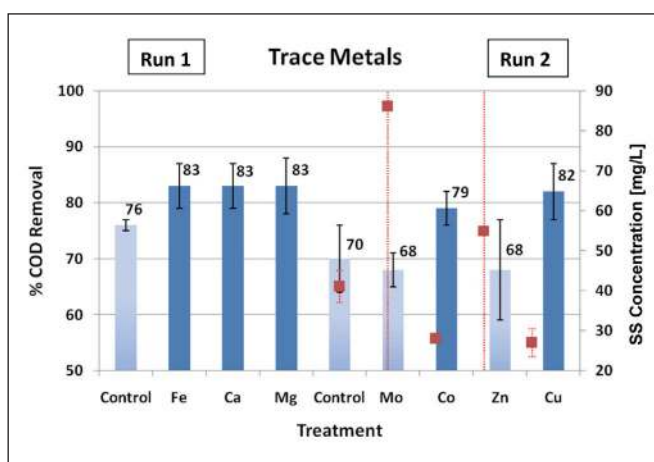

Fig. 3 Mean % COD removal for trace element additions from Run 1 and Run 2 with Standard Deviations indicated in black. Red squares represent the mean SS concentration with Standard Deviations in red. The light blue bars represent the control pots and those pots with no significant difference to the control, the dark blue bars represent statistically significant increase in the COD removal.

RUN TWO

Four separate trace metals were added from bulk solutions during Run 2 to give final target concentrations in the porous pots of: Co 0.06 mg/L, Mo 0.06 mg/L, Cu 0.59 mg/L and Zn 0.59 mg/L. The mean COD removal for the control pot over 10 days was found to be $70 \pm 6\%$. It was found that there was no significant difference for the Mo and Zn addition pots compared to the control pot, with $68 \pm 3\%$ and $68 \pm 9\%$ COD removal, respectively (Fig. 3). However, while the maximum COD removal in the zinc pot reached 85% on day 11, it decreased to 61% on the final day of the run. This is reflected in the relatively high standard deviation (9%) of the COD results for this pot. As expected there was a correlation between the COD removal and the SS concentration. As the COD removal in the pots amended with Mo and Zn declined the SS concentration increased, as indicated by the relatively high standard deviation. The COD removal in pots amended with Co and Cu were stable through the run and the corresponding SS concentration was significantly lower than the control (Fig. 3).

There was a significant statistical difference between the control and the Cu and Co addition pots ($P = 0.022$, $df = 7$) and ($P =$

0.044 , $df = 7$), respectively. The increase in COD removal for the Cu and Co pots was 12% and 9% respectively.

It is believed that, though the total Zn concentration in the pot, was about 0.85 mg/L (0.25 mg/L background, plus 0.59 mg/L addition) and well within the 0.1 to 1.0 mg/L target range, that there could have been a residual Zn build up in the pot. The Zn could have accumulated to such an extent that it was toxic to the microbial populations in the sludge. While the addition of Zn has been found to be toxic to AS microorganisms at concentrations >1.0 mg/L (4, 20), the same addition has also been reported to increase microorganism growth (14). Further, in a separate study zinc addition to this level increased COD removal by a factor of 1.3 times (17).

There have also been conflicting results reported from the addition of Mo. Burgess *et al.* reported in two separate studies that 0.5 mg/L Mo had both beneficial and toxic effects on the effluent quality (4, 20). The same authors also reported that 2.0 mg/L Mo increased COD removal by 1.4 times (17).

In the case of copper addition the result is as expected as the addition of between 0.014 – 1.0 mg/L Cu to industrial wastewater treatment plants has been reported to increase both COD removal and effluent quality (10, 31).

For Cobalt the results is as expected as the concentration at which Co has a toxic effect on the AS has been reported to be >1.0 mg/L (9), while up to 1.0 mg/L it has been reported to enhance COD removal (20).

RUN THREE

Runs 3 and 4 were undertaken with the addition of one of six water soluble B-group vitamins to give a final concentration of 1.0 mg/L of a given vitamin. The vitamins added in Run 3 were B_1 , B_2 and B_3 .

The mean COD removal for the control pot was $78 \pm 4\%$, with no significant difference between the COD removal from the control pot and B_1 and B_2 additions (Fig. 4). There was a significant negative difference for B_3 addition with mean COD removal of $59 \pm 4\%$, a decrease of 19% compared to the control. The SS data indicated the same trends as the COD removal from

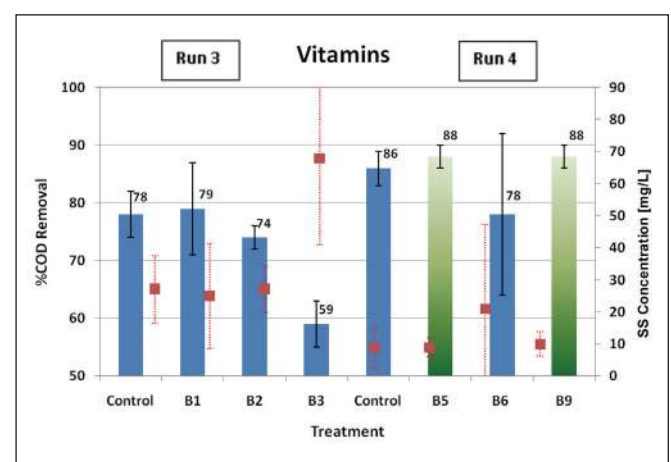

Fig. 4 Mean % COD removal for vitamin additions in Run 3 and Run 4 with standard deviations indicated in black. Red squares represent the mean SS concentration with Standard Deviation in red. The light blue bars represent the control pots and those pots with no significant difference to the control, the clear bar indicates a significant decrease and the green bars represent minimal increases.

Run 3. There was a significant decrease in the SS concentration from B₃, 68 ± 27 mg/L while there was no significant difference from pots B₁ and B₂ compared to the control (Fig. 4).

The result for vitamin B₂ was in agreement with previous reports for Vitamin B₂ where the addition of 1.0 mg/L B₂ to industrial wastewater gave no significant improvement (4). On the other hand, Wei *et al.* report that the addition of 1.0 mg/L B₁ to wastewater from a textile mill increased COD removal by a factor of 1.6 times (17), a result not reflected in the current work. The result for vitamin B₃ obviously contradicts a number of other reports where the addition of between 0.1 – 1.0 mg/L B₃ to synthetic and industrial wastewater has been observed to increase COD removal in wastewater treatment plants by 15 – 200% (4, 7, 9, 17, 20, 21, 32).

RUN FOUR

Vitamins B₅, B₆ and B₉ were added in Run 4, where the mean COD removal for the control pot was 86 ± 3%. The COD removals in B₅ and B₉ pots were both 88 ± 2% (P – 0.089) and (P – 0.104), respectively (see Fig. 4). Though these were apparently better COD removals than the control, they were not within the set statistical parameters of 95% confidence level to report a significant difference. There was also no difference found in the concentration of SS between the control, and B₅ and B₉ additions, supporting the COD removal data.

The mean COD removal in the B₆ pot was less than the control but not significantly lower due to the comparatively high standard deviation, 78 ± 14%.

While the addition of 1.0 mg/L B₅ has been reported to increase COD removal (4), this was not found in the current work. Similarly, while the effects of B₉ addition on COD removal have not been reported directly, it has been reported to improve settling (33). Again, this effect was not seen here. Reports on vitamin B₆ in the literature have varied considerably. Burgess *et al.* (21) has reported that the addition of 1.0 mg/L B₆ trebled COD removal in P limited wastewater compared to the control. Burgess *et al.* (20) also reported that the addition of 0.01 µg/L B₆ stimulated bacterial growth, however, did not increase the rate of COD removal.

In the B₆ pot there was a noticeable transformation from day 21, reflected in a decrease in the COD removal and an increase in SS. The mean COD removal prior to day 21 was 89% with a mean SS concentration of 9 mg/L. From day 21 to day 26 there was a linear decrease in the COD removal from 89% to 56% with a corresponding SS increase from 9 mg/L to 82 mg/L. At the same time there was an increase in flagellates and foaming. Though this can indicate low DO (34, 35), the DO levels in the B₆ pot remained between 1.8 and 4.8 mg/L throughout the run. It was not likely that the B₆ concentration saturated the AS to a toxic level due to the relatively high theoretical requirement of 10.0 mg/L (4), and no reports of toxicity. This may indicate that while the B₆ concentration was within the required range, leading to COD removal of 89% on day 21, the increase in flagellates and foaming implies that there were other operational issues in the porous pot.

CONCLUSION

Based on accepted levels of trace metals for optimum biological activity in the SETP Cu, Co, Mo and Fe were found to be deficient. Upon the addition of these metals individually to a series of porous pot experiments, along with additions of Ca and Mg, it was found that Fe, Ca and Mg each increased COD removal by 7% compared to the control, while Cu and Co each increased COD removal by 12% and 9%, respectively. There was no significant difference when Mo or Zn was added.

In general there was a strong correlation between COD removal and SS level, while in the cases of Cu and Co addition there was a 14 mg/L and 13 mg/L decrease in the SS levels, respectively.

The effects of metal addition on the effluent and sludge concentration will be investigated in future studies.

The additions of vitamins did not produce as noticeable an effect on the COD removal as the trace metal additions. Addition of vitamins B₁, B₂, B₅ and B₉ produced no significant difference in the COD removal and the SS concentration compared to the control. However, there was a significant negative effect for the additions of B₃ and B₆, where the COD removals decreased by 21% and 8%. The mean B₃ and B₆ SS levels increased by 41 mg/L (252%) and 12 mg/L (233%) respectively compared to the control mean.

ACKNOWLEDGEMENTS

The author would like to acknowledge Norse Skog for making available the funding for the project and Dr Ashley Townsend at the Central Science Laboratory (CSL), University of Tasmania for the ICP MS analysis and Mr Peter Dove also at CSL for fabrication of the porous pots.

REFERENCES

- (1) Halttunen, S. and Jansson, K. - Sludge Story. *Pulp and Paper Europe*, 7(1): 16 - 18 (2002)
- (2) In Tchobanoglous, G., Burton, F. and Stensel, H., **Wastewater Engineering: Treatment and Reuse**. 4th edition ed. New York: McGraw-Hill (2003).
- (3) Clark, T. and Stephenson, T. - Effects of chemical addition on aerobic biological treatment of municipal wastewater. *Environmental Technology*, 19(6): 579-590 (1998).
- (4) Burgess, J., Quarmby, J. and Stephenson, T. - Micronutrient supplements for optimisation of the treatment of industrial wastewater using activated sludge. *Water Research*, 33(18): 3707 - 3714 (1999).
- (5) Burgess, J., Quarmby, J. and Stephenson, T. - Vitamin addition: an option for sustainable activated sludge process effluent quality. *J. of Ind. Microbiology and Biotechnology*, 24: 267 - 274. (2000).

- (6) Liang, W. *et al.* - Effects of micronutrients on biological treatment efficiency of textile wastewater. *Fresenius Environmental Bulletin*, **16**(12a): 1578-1582 (2007).
- (7) Wei, L. *et al.* - Micronutrient niacin addition to enhance biological treatment of textile wastewater. *Fresenius Environmental Bulletin*, **16**(4): 393-396 (2007).
- (8) Ji, G. and Silver, S. - Bacterial resistance mechanisms for heavy metals of environmental concern. *J. of Industrial Microbiology*, **14**(2): 61-75 (1995).
- (9) Burgess, J.E., Quarmby, J. and Stephenson, T. - Role of micronutrients in activated sludge-based biotreatment of industrial effluents. *Biotechnology Advances*, **17**(1): 49-70 (1999).
- (10) Stover, E.L. *et al.* - Correcting activated sludge inhibition by addition of trace amounts of copper. *Proc. Environment Federation*, **2000**: 688-707 (2000).
- (11) In Manahan, S., **Environmental Chemistry**. 8th Edition. Boca Raton: CRC Press. p. 783 (2005).
- (12) In Madigan, M. and Martinko J., **Brook: Biology of Microorganisms**. 11th Edition New Jersey: Pearson Prentice Hall (2006)
- (13) Bagby, M.M. and Sherrard, J.H. - Combined Effects of Cadmium and Nickel on the Activated Sludge Process. *J. Water Pollution Control Federation*, **53**(11): 1609-1619 (1981).
- (14) Cabrero, A. *et al.* - Effects of copper and zinc on the activated sludge bacteria growth kinetics. *Water Research*, **32**(5): 1355-1362 (1998).
- (15) Gikas, P. - Single and combined effects of nickel Ni(II) and Co(II) ions on activated sludge and on other aerobic microorganisms: A review. *J. Hazardous Materials*, **159**: 187 - 203 (2008).
- (16) Grau, P. - Criteria for nutrient-balanced operation of activated sludge process. *Water Science and Technology*, **24**(3/4): 251 - 258 (1991).
- (17) Wei, L. *et al.* - Effects of micronutrients on biological treatment efficiency of textile wastewater. *Fresenius Environmental Bulletin*, **16**(12a): 1578-1582 (2007).
- (18) Campbell, L. and Williams, O. - The effect of temperature on the nutritional requirements of facultative and obligate thermophilic bacteria. *J. Bacteriology*, **65**: 141-145 (1953).
- (19) Lind, G. *et al.* - Use of vitamins in biological wastewater treatment. *Wasser Abwasser*, **135**(10): 595-600 (1994).
- (20) Burgess, J., Quarmby, J. and Stephenson, T. - Micronutrient supplements to enhance biological wastewater treatment of phosphorus-limited industrial effluent. *Trans IChemE*, **77**: 199-204 (1999).
- (21) Burgess, J. *et al.* - Nutrient balancing for enhanced activated sludge reactor performance: UK perspective. *Water Science and Technology*, **41**(12): 223 - 231 (2000)
- (22) Wood, D.K. and Tchobanoglous, G. - Trace Elements in Biological Waste Treatment. *J. Water Pollution Control Federation*, **47**(7): 1933-1945 (1975).
- (23) Dias, F. and Bhat, J. - Microbial Ecology of Activated Sludge. *Applied Microbiology and Biotechnology*, **12**(5): 412-417 (1964).
- (24) Lemmer, H. *et al.* - Vitamin addition in biological wastewater treatment. *Water Science and Technology*, **37**(4/5): 395 - 398 (1998).
- (25) *Porous Pot Test*, P.P.a.T. Substances, Editor. 1998, USEPA. p. 22.
- (26) *Simulation Test - Aerobic Sewage Treatment: A. Activated Sludge Units*, USEPA, Editor. 2008. p. 37.
- (27) Stennett, G. and Eden, G. - Assessment of biodegradability of synthetic surfactants by test s simulating sewage treatment. *Water Research*, 1971. **5**: p. 601-609.
- (28) In **Standard Methods for the Examination of Water and Wastewater**. 21st Edition. ed. A. Eaton, *et al.* Washington: American Public Health Association. (2005),
- (29) Tsang, Y. *et al.* - A novel technology for bulking control in biological wastewater treatment plant for pulp and paper making industry. *Biochemical Engineering J.*, **32**: 127-134 (2006).
- (30) Martins, A.M.P. *et al.* - Filamentous bulking sludge--a critical review. *Water Research*, **38**(4): 793-817 (2004).
- (31) Dilek, F., Gokcay, C. and Yetis, U. - Effects of Cu(II) on a chemostat containing activated sludge. *Environmental Technology*, **12**(11): 1007-1016 (1991).
- (32) Wei, L. *et al.* - Effects of micronutrient niacin on treatment efficiency of textile wastewater. *Wuhan University J. Natural Sciences*, **11**(3): 737-741 (2006).
- (33) Akerboom, K., Lutz, P. and Berger, F. - Folic acid reduces the use of secondary treatment additives in treating wastewater from paper recycling, *Proc. Intl. Environmental Conf. TAPPI*. 941-946. (1994)
- (34) In Eikelboom, D., **Process control of activated sludge plants by microscopic investigation**. London: IWA Publishing. p. 156. (2000).
- (35) Jenkins, D., Richard, M. and Daigger, G. - **Manual of the Causes and Control of Activated Sludge Bulking, Foaming, and Other Solids Separation Problems**. 3rd Edition ed. London: CRC Press. p. 190. (2004).

Original manuscript received 8 March 2012, revision accepted 16 May 2012.