

ADDRESS – ACTIVE DEMAND FOR THE SMART GRIDS OF THE FUTURE

Régine BELHOMME
EDF – France
regine.belhomme@edf.fr

Ramon CERERO REAL DE ASUA
Iberdrola Distribución – Spain
ramon.cerero@iberdrola.es

Giovanni VALTORTA
ENEL Distribuzione - Italy
giovanni.valtorta@enel.it

Andrew PAICE
ABB – Switzerland
andrew.d.paice@ch.abb.com

François BOUFFARD
University of Manchester – United Kingdom
francois.bouffard@manchester.ac.uk

Rudy ROOTH
KEMA – The Netherlands
rudy.rooth@kema.com

Arturo LOSI
University of Cassino – Italy
losi@unicas.it

ABSTRACT

The ADDRESS European project aims to deliver a comprehensive commercial and technical framework for the development of “Active Demand” in the smart grids of the future. Specifically, ADDRESS will investigate how to effectively activate participation of domestic and small commercial customers in the power system markets and in the provision of services to the different power system participants.

This paper gives an overview of the project: its objectives, scope and first draft architecture, the concepts that will be specifically developed to meet the objectives, the methodology adopted for development and validation, the main expected results and the project consortium.

INTRODUCTION

The recent development of Information and Communication Technologies, advanced metering systems, energy management at the local level (houses, commercial buildings, and industrial facilities) as well as household technologies open new opportunities for demand response. At the same time, there is a growing need for a more active participation of demand in power systems, and consumers are increasingly concerned about environmental and energy efficiency issues.

In this context, the ADDRESS European project (“Active Distribution networks with full integration of Demand and distributed energy RESources”) aims to deliver a comprehensive commercial and technical framework for the development of “Active Demand” in the smart grids of the future, or in other words for the active participation of domestic and small commercial customers in the power system markets and in the provision of services to the different power system participants.

This paper gives an overview of the project: consortium, its objectives, scope and first draft architecture. We further discuss the concepts that will be developed to meet the objectives, the methodology adopted for development and validation, and, finally, the main expected results.

ADDRESS: EUROPEAN PROJECT UNDER FP 7

ADDRESS is a 4-year large-scale R&D project launched in June 2008 that will receive funding from the European Community's Seventh Framework Programme (FP7/2007-2013) under grant agreement n° 207643 [1]. The project coordinator is ENEL Distribuzione and the consortium consists of 25 partners from 11 European countries (see Fig. 1) spanning the entire electricity supply chain, qualified R&D bodies, SMEs and manufacturers.

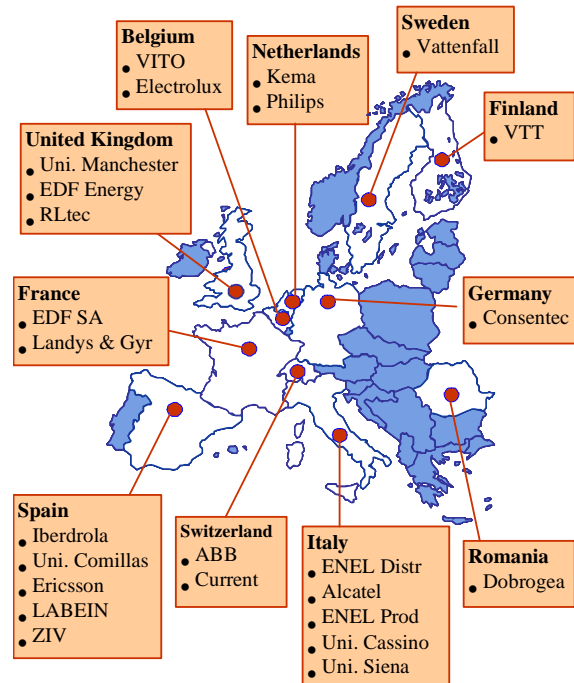

Figure 1: ADDRESS Consortium

PROJECT OBJECTIVES

ADDRESS will develop technical solutions both at the consumers’ premises and at the power system level to enable active demand and to allow real-time response to requests from markets and/or other power system participants.

This also implies identifying the possible barriers against active demand deployment and proposing solutions to remove these barriers. In particular, a scaleable and open communication architecture will make it possible to deal in real time with large numbers of consumers (hundred thousand and above). In addition to technical questions, ADDRESS will also deal with regulatory, economic, societal and cultural aspects which may also be the root causes of possible barriers.

Complementarily, another objective is to identify the possible benefits of active demand for the different power system participants and develop the appropriate contractual and market mechanisms needed for the exploitation of these benefits. In addition to technical and economic issues accompanying measures will also be studied in dealing with small consumer societal, cultural and behavioral factors. They will be supported by dedicated dissemination activities for the different types of stakeholders.

SCOPE AND FIRST ARCHITECTURE

Figure 2 shows the scope of the project, along with a first draft architecture, building on the architecture developed in the FENIX European project [2]. Combined aggregation of active demand with grid-connected distributed generation will thus be possible.

In the proposed architecture, Aggregators are the mediators between the consumers and the markets. They play a central role for both sides:

- They will collect the requests and signals coming from the markets and the different power system participants (see Section ADDRESS MAIN CONCEPTS),
- They will gather the “flexibilities” and contributions provided by the consumers to meet those requests and

signals and to offer the services to the different power system participants through the markets.

Markets (“Markets and contracts” in Fig. 2) consist of all kinds of commercial agreements between power system participants (such as contracts, forward markets, real-time markets). Markets for different products and services will hence be considered:

- Energy supply,
- Ancillary services in the form of steady state voltage control, tertiary frequency control and active tertiary reserve,
- Balancing services (and compensation of variability from Renewable Energy Sources),
- Overload and network congestion relief,
- Load shaping services (and in particular load shaving).

Distribution System Operators (DSOs) also play an important role because Active Demand (as developed in the project) concerns consumers connected to distribution grids. DSOs will still continue to ensure secure and efficient network operation. They will do so mainly through interactions with the other power system participants and in particular with the aggregators via markets. They will also maintain direct interactions (and direct electrical contracts) with the TSOs in ensuring secure network operation.

ADDRESS MAIN CONCEPTS

The following concepts will be specifically developed within the project in order to achieve the objectives:

- Interaction through real-time price and volume signals,
- A new approach (the “Demand Approach”) to foster the flexibility and active participation of consumers,
- Distributed intelligence and local optimization.

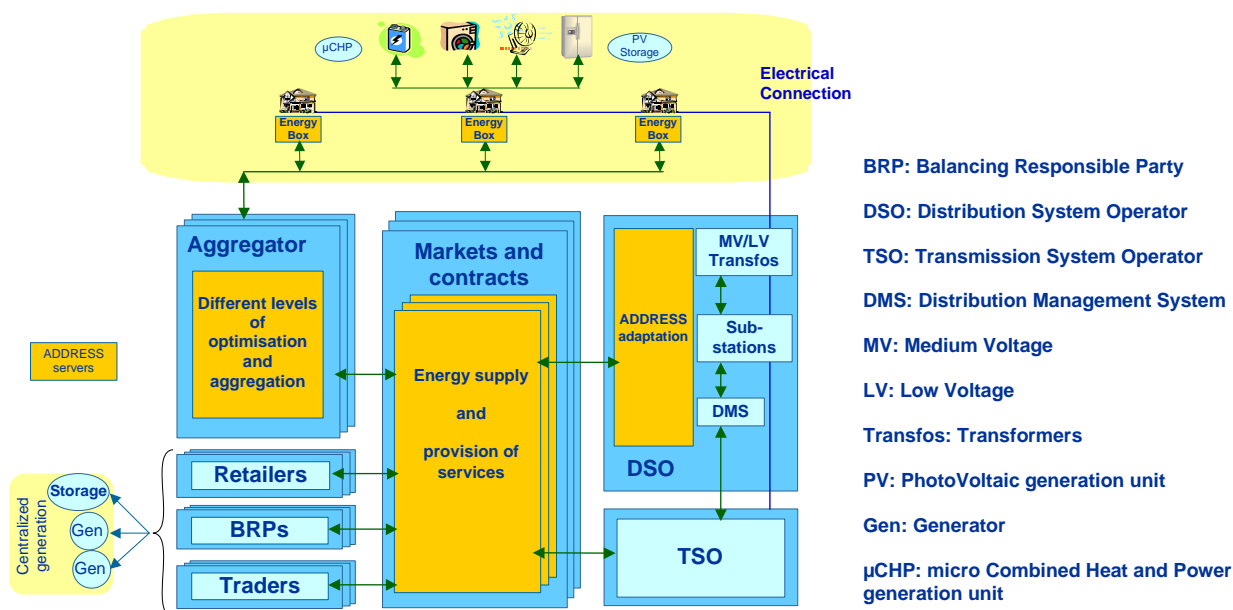

Figure 2: Scope and extent of the ADDRESS project

Real time price and volume signals

In the proposed architecture, the basis for the interaction between the power system participants will be the exchange of two types of signals: real-time price signals and real-time volume signals (mainly power-based signals). “Real time” here means a time scale of 20 to 30 minutes ahead.

Depending on the service to be provided, these signals may also be modulated by geographical/topological information. Direct control of the loads by the DSOs will not be studied as such. However, the project will investigate the limits of using only price and volume signals to ensure secure network operation.

The “Demand Approach”

A new approach is needed to deal with active demand: it may be called the “Demand Approach” in contrast to the “Generation Approach” that is generally used to deal with generation and in particular distribution generation (DG). Contrary to DG and large industrial customers, domestic customers are not motivated purely by economic considerations. Moreover, they are not able or not prone to characterize precisely in advance the services and flexibilities that they can provide (due to the lack of appropriate equipment). Therefore, the services they could provide will be “requested” through the developed price and/or volume signal mechanisms and will be provided on a voluntary and contractual basis.

To support this approach, appropriate technologies have to be developed both within dwellings and at the interface with the aggregator. Technologies must be complemented with relevant accompanying measures. These will be studied with a particular focus on societal, cultural and behavioral factors.

Distributed intelligence and local optimization

Local optimization will be needed to meet the requirements of the topologically-dependant services that will be requested. Therefore, different levels and amounts of distributed intelligence will be required. The issue then is to put the “right amount” of intelligence at the “right place.” All power system participants will probably need local intelligence to optimize their real-time response to the other power system participants according to the real-time signals mentioned above. However, due their central roles, the following participants will receive a special attention and will be studied individually in the project (see Figure 2):

- The consumer: how to implement intelligence at the consumer premises,
- The aggregator: different levels of optimization and aggregation will be needed, and
- The DSO: to enable and exploit the benefits of active demand, distributed intelligence will be required at different levels in the distribution networks.

Building on FENIX concepts

In building the smart grids of the future, active demand could not be considered alone. The secure and reliable

operation of the distribution networks must take into account distributed generation, energy storage systems and large customers connected at the MV level.

In this respect, the concepts developed in the FENIX project [2, 3] and in other European or international programs on related subjects (see for instance [4, 5]) will be adapted, enhanced or extended in ADDRESS to allow the massive deployment of active demand. They will be complemented by additional developments whenever required to enable the implementation of ADDRESS concepts.

METHODOLOGY FOR DEVELOPMENT AND VALIDATION

The project structure is closely related to the methodology adopted for the development and validation of ADDRESS concepts and solutions. It is shown on Figure 3.

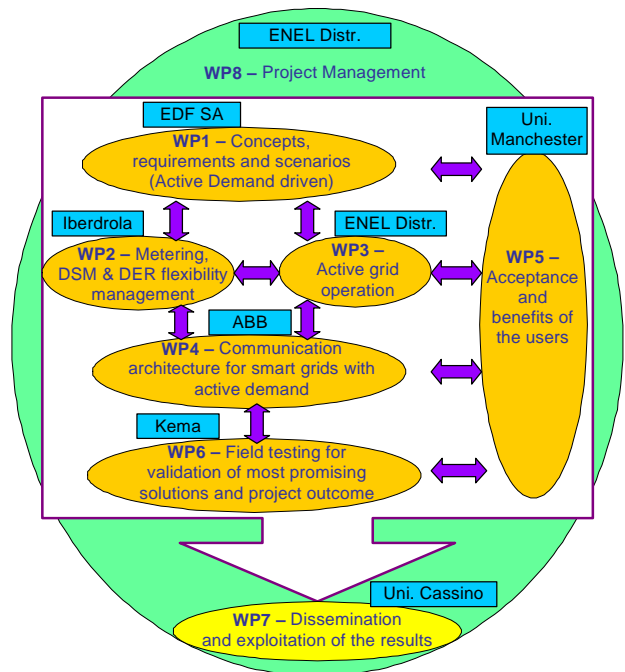

Figure 3: Project structure and methodology

Specifically, the methodology implies the following steps:
 1) Develop the concepts mentioned above and in particular the mechanisms used to formulate price and volume signals ⇒ ADDRESS Work Package 1 (WP1).
 2) Define the ADDRESS technical and commercial architecture and the functional requirements based on the above concepts in the context of 4 or 5 scenarios. These scenarios will be chosen to reflect different representative power systems in Europe ⇒ WP1.
 3) Develop the enabling technologies and algorithms as well as prototypes, and test them individually in laboratories. Development (algorithms and prototypes) will be carried out in detail for the following three power system participants: consumers, aggregators and DSOs. The interactions with the other power system participants will be simulated using simplified models that include a sufficient

amount of detail to allow the proper validation of the approach ⇒ WP2 (for consumers up to appliances, aggregators and other deregulated market participants¹), WP3 (for DSOs and TSOs), WP4 (communication architecture).

4) Install the prototypes at three different field test sites with different demographic and generation characteristics in Spain, Italy and on a French island, and validate the concepts and the solutions developed ⇒ WP6.

5) Develop the contractual, market and regulatory mechanisms needed for the exploitation of the benefits of active demand. Develop recommendations for accompanying measures with regard to social acceptance ⇒ WP5.

6) Define recommendations for different stakeholders: regulators, communities and power system participants ⇒ WP5, WP7.

7) Communicate the results ⇒ WP7.

MAIN EXPECTED RESULTS

Table 1 shows the main results expected in the first six WPs of ADDRESS, along with the foreseen delivery dates expressed in quarters (Q) of a specific year.

Dedicated dissemination activities (WP7) for different types of stakeholders will be carried out along the time span of the project: website, publications, brochures, press releases, presentation in conferences, and international committees and in working groups, and regional workshops. Moreover, two international workshops will be held, one at mid-term and the other at the end of the project.

CONCLUSION

The active participation of domestic and small commercial consumers to the provision of services will be an essential ingredient of the smart distribution grids of the future, and is likely to bring multiple benefits to the different power system participants. In this respect, ADDRESS presents a unique and timely opportunity to coordinate and combine the expertise and resources of partners from all over Europe in order to develop solutions capable both to foster this participation and exploit its benefits to the fullest. In particular, the project results are expected to contribute to:

- Enabling real-time pricing for all network users;
- Improving the security of supply of critical loads;
- Increasing the efficiency, flexibility, safety, reliability and quality of the European power systems in the context of a more integrated European energy market.

REFERENCES

[1] European Community, Seventh Framework Programme, *Description and Information* available on http://cordis.europa.eu/fp7/home_en.html.
 [2] D. Pudjianto, C. Ramsay, G. Strbac, 2007, "The

¹ Retailers, traders, Balance Responsible Parties, producers

Table 1 – Main expected results

WP	Description	Date
1	Conceptual architecture including description of participants, signals exchanged, markets and market interactions, overall expected system functional behaviour. Application in 4 or 5 specific scenarios.	Q3 2009
2	Algorithms for aggregators and consumers. Simplified models for the other participants.	Q4 2010
	Prototype equipment for local energy management and control of load, generation and storage.	Q2 2011
3	Prototypes and algorithms for network management, providing the signals sent by the DSOs to the aggregators and the markets.	Q2 2011
4	Communication Architecture: documentation of Software Architecture, including compiled software with API description	Q4 2010
	Technical guide for building up a Smart Grids telecommunication infrastructure	Q2 2011
5	Report on market mechanisms (regulation, economic incentives and contract structures) which enable active demand participation.	Q2 2011
	Key economic and societal factors influencing the adoption of the ADDRESS architecture for power system participants. Report on the results verified by the experience obtained in the field tests.	Q2 2012
	Business cases for consumers, aggregators and DSOs in the scenarios detailed in WP1	Q2 2012
6	Description of field test location and detailed test program for field test, complementary simulations and hybrid tests.	Q2 2011
	Assessment of the field test results and performance of the developed prototypes.	Q2 2012
	Evaluation of ADDRESS concepts and solutions with regard to the deployment of active demand and the large scale integration of Distributed Energy Resources	Q2 2012

FENIX vision: the virtual power plant and system integration of distributed energy resources", *FENIX Deliverable 1.4.0*, available on www.fenix-project.org.

[3] M. Sebastian, J. Marti, P. Lang, 2008, "Evolution of DSO control centre tool in order to maximize the value of aggregated distributed generation in smart grid", *Proceedings CIRE D Seminar 2008: Smart grids for Distribution*, Paper No. 0034.
 [4] DISPOWER European project, "Distributed generation with high penetration of renewable energy sources", *Information and Deliverables* available on www.dispower.org.
 [5] EPRI's IntelliGrid Initiative and IntelliGrid Architecture, *Information available on http://intelligrid.epri.com/ and http://intelligrid.info/*.