

NASA/TP—2004—212068

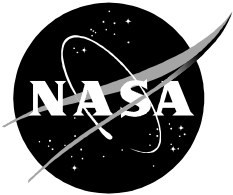

**Advanced EVA Capabilities:
A Study for NASA's Revolutionary Aerospace Systems
Concept Program**

*Stephen J. Hoffman, Ph.D.
Science Applications International Corporation
Houston, Texas*

April 2004

The NASA STI Program Office ... in Profile

Since its founding, NASA has been dedicated to the advancement of aeronautics and space science. The NASA Scientific and Technical Information (STI) Program Office plays a key part in helping NASA maintain this important role.

The NASA STI Program Office is operated by Langley Research Center, the lead center for NASA's scientific and technical information. The NASA STI Program Office provides access to the NASA STI Database, the largest collection of aeronautical and space science STI in the world. The Program Office is also NASA's institutional mechanism for disseminating the results of its research and development activities. These results are published by NASA in the NASA STI Report Series, which includes the following report types:

- **TECHNICAL PUBLICATION.** Reports of completed research or a major significant phase of research that present the results of NASA programs and include extensive data or theoretical analysis. Includes compilations of significant scientific and technical data and information deemed to be of continuing reference value. NASA counterpart of peer-reviewed formal professional papers, but having less stringent limitations on manuscript length and extent of graphic presentations.
- **TECHNICAL MEMORANDUM.** Scientific and technical findings that are preliminary or of specialized interest, e.g., quick release reports, working papers, and bibliographies that contain minimal annotation. Does not contain extensive analysis.
- **CONTRACTOR REPORT.** Scientific and technical findings by NASA-sponsored contractors and grantees.

- **CONFERENCE PUBLICATION.** Collected papers from scientific and technical conferences, symposia, seminars, or other meetings sponsored or co-sponsored by NASA.
- **SPECIAL PUBLICATION.** Scientific, technical, or historical information from NASA programs, projects, and missions, often concerned with subjects having substantial public interest.
- **TECHNICAL TRANSLATION.** English-language translations of foreign scientific and technical material pertinent to NASA's mission.

Specialized services that complement the STI Program Office's diverse offerings include creating custom thesauri, building customized databases, organizing and publishing research results ... even providing videos.

For more information about the NASA STI Program Office, see the following:

- Access the NASA STI Program Home Page at <http://www.sti.nasa.gov>
- E-mail your question via the Internet to help@sti.nasa.gov
- Fax your question to the NASA STI Help Desk at (301) 621-0134
- Telephone the NASA STI Help Desk at (301) 621-0390
- Write to:
NASA STI Help Desk
NASA Center for AeroSpace Information
7121 Standard Drive
Hanover, MD 21076-1320

NASA/TP—2004—212068

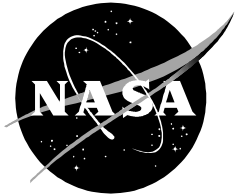

**Advanced EVA Capabilities:
A Study for NASA's Revolutionary Aerospace Systems
Concept Program**

*Stephen J. Hoffman, Ph.D.
Science Applications International Corporation
Houston, Texas*

National Aeronautics and
Space Administration

Lyndon B. Johnson Space Center
Houston, Texas 77058

April 2004

Acknowledgments

The editor would like to acknowledge the assistance of those individuals who aided in the preparation of this document. Mr. William Cirillo and Dr. Marianne Rudisill of the Langley Research Center initiated this study under the Revolutionary Aerospace Systems Concepts program and provided guidance throughout its development. Mr. Joe Kosmo and Mr. Richard Fullerton of the Johnson Space Center provided technical direction and assistance in gathering these materials. Mr. Robert Sauls of Frassanito and Associates prepared the animations and many of the illustrations of advanced EVA systems in this report. Ms. Erika Guillory of DynCorp Technical Services and Mr. Donn Sickorez of the Johnson Space Center narrated the animations.

Available from:

NASA Center for AeroSpace Information
7121 Standard Drive
Hanover, MD 21076-1320
301-621-0390

National Technical Information Service
5285 Port Royal Road
Springfield, VA 22161
703-605-6000

This report is also available in electronic form at <http://techreports.larc.nasa.gov/cgi-bin/NTRS>

FOREWORD

“All men dream but not equally. Those who dream by night in the dusty recesses of their minds wake in the day to find that it was vanity; but the dreamers of the day are dangerous men for they may act out their dreams with open eyes, to make it possible.”

Thomas Edward Lawrence (1888 – 1935) Seven Pillars of Wisdom

Humans have been living and working in space for over 40 years and have been performing extravehicular activities (EVAs) for over 35 years. During this time, EVA crews have spent approximately 900 hours in the microgravity environment and over 160 hours on the lunar surface. This capability has been and remains an important part of working in space.

This report, however, is about the future of working in space; the relatively distant future. It describes a vision of that future and the role of EVA in it. This vision attempts to take into account what experience has taught us and what our plans require.

But that future is not set. The Revolutionary Aerospace Systems Concepts Program attempts to look beyond the horizon, where extrapolation of current technology is inadequate and predictions are considered by many to be little more than dreaming. This report was prepared in the spirit of the “dreamer of the day”—to understand where technology could go and where our mission plans could take us, so we can lay out a roadmap to make this future possible.

Stephen J. Hoffman, Ph.D.
November 2003

TABLE OF CONTENTS

| | Page |
|---|------|
| Foreword | iii |
| Table of Contents | v |
| List of Tables | vii |
| List of Figures | viii |
| Acronyms and Abbreviations | xv |
| | |
| EXECUTIVE SUMMARY | xix |
| | |
| 1. INTRODUCTION | 1 |
| 1.1 Overview | 1 |
| 1.2 The RASC Program | 1 |
| 1.3 Study Approach | 3 |
| 1.4 Report Outline | 4 |
| 2. A VISION OF THE FUTURE OF EVA AND EVA SYSTEMS | 5 |
| 2.1 NASA’s Strategic Plan | 5 |
| 2.2 Future Human Exploration Missions | 7 |
| 2.3 EVA Functional Requirements | 21 |
| 2.4 Summary | 22 |
| 3. EVA SYSTEMS ARCHITECTURE AND FUNCTIONAL CAPABILTIES | 23 |
| 3.1 EVA System Functional Breakdown Structure | 23 |
| 3.2 EVA History and Current State of the Art | 25 |
| 3.3 Lessons Learned From the Apollo Missions | 28 |
| 3.4 Expanded Functional Requirements and Mission Requirements | 29 |
| 3.5 Summary | 31 |
| 4. REVOLUTIONARY CONCEPTS | 33 |
| 4.1 Concept Solicitation From the EVA Development Community | 33 |
| 4.2 Other Advanced or Revolutionary Concepts | 35 |
| 4.3 Summary | 38 |
| 5. EVA TECHNOLOGIES AND DEVELOPMENT ROADMAP | 39 |
| 5.1 Other Roadmaps | 39 |
| 5.2 RASC Roadmap Recommendations | 42 |
| 5.3 Summary | 44 |
| 6. SUMMARY AND RECOMMENDATIONS | 45 |
| 7. REFERENCES | 47 |
| | |
| Appendix A: EVA System Hierarchy | 49 |
| Appendix B: EVA System History | 53 |

| | |
|--|-----|
| Appendix C: EVA System Current State of the Art | 87 |
| Appendix D: Lessons Learned From Apollo Lunar Surface EVAs | 127 |
| Appendix E: Advanced/Revolutionary Concepts | 135 |
| Appendix F: Bibliography | 143 |

TABLES

| Table Number | | Page |
|-------------------------|--|-------------|
| 3.4-1 | A description of current state of the art and future needs for EVA systems | 29 |
| 4.1-1 | Organizations invited to submit concepts or suggestions for revolutionary EVA concepts | 33 |
| 5.1-1 | Space robotic functionalities | 40 |
| C.1-1. | A comparison of key features of three advanced PLSS packaging concepts | 105 |
| C.2-1 | Characteristics and capabilities of the Mobile Servicing System | 107 |
| C.4-1 | A comparison of aircraft characteristics pertinent to EVA training and tests | 120 |

FIGURES

| Figure Number | | Page |
|---------------|--|------|
| 1.2-1 | The RASC vision. A methodology to develop and analyze revolutionary missions and architecture concepts to identify enabling advanced technology requirements. | 2 |
| 1.3-1 | Tailored RASC process leading to Advanced EVA Roadmap. | 3 |
| 2.1-1 | The NASA Strategic Plan (2003) envisions a number of objectives for exploring the solar system coupled with a “stepping stone” approach to expanding our presence into the solar system as we pursue these objectives. | 6 |
| 2.2-1 | Animation of EVA maintenance and servicing activities at a free-space facility. Double click on the WEB.MOV icon to activate the animation. | 8 |
| 2.2-2 | The FAIR-DART Telescope concept. | 8 |
| 2.2-3 | Animation of EVA assembly and checkout of a FAIR-DART telescope. Double click on the WEB.MOV icon to activate the animation. | 9 |
| 2.2-4 | A solar eclipse as seen from the lunar surface – an example of a unique astronomical perspective offered by a lunar surface astronomical facility. | 11 |
| 2.2-5 | Setup, monitoring, and adjusting test bed systems will require EVA support. | 12 |
| 2.2-6 | Animation of a range of surface exploration activities expected for lunar operations. Double click on the WEB.MOV icon to activate the animation. | 13 |
| 2.2-7 | Field work activities as they may be carried out by a number of agents on the surface of Mars. Double click on the WEB.MOV icon to activate the animation. | 16 |
| 2.2-8 | Crew operating from a field camp will allow interesting sites to be explored in more detail than would be possible if the EVA were staged from the landing site. | 16 |
| 2.2-9 | Field work activities as they may be carried out from pressurized rovers or from field camps. Double click on the WEB.MOV icon to activate the animation. | 18 |
| 2.2-10 | An artist’s concept for a maintenance and repair facility within the pressurized habitat. This facility will be capable maintaining the EVA suits that will be a key element in supporting the crew’s | 18 |

| Figure Number | | Page |
|--------------------------|---|-------------|
| | exploration activities. | |
| 2.2-11 | A map of asteroids, with nearly circular orbits, found in the inner solar system. The orbits of Earth, Mars and Jupiter are also indicated in blue. | 19 |
| 2.2-12 | Animation of an asteroid mission using a self-contained, one person EVA craft. Double click on the WEB.MOV icon to activate the animation. | 20 |
| 2.2-13 | Animation of a mission to Callisto, one of Jupiter's moons. Double click on the WEB.MOV icon to activate the animation. | 20 |
| 3.1-1 | An overview of key EVA infrastructure support equipment and system elements. | 24 |
| 3.1-2 | EVA system hierarchy. | 25 |
| 3.2-1 | An overview of EVA activities from the first space walk by Alexei Leonov through current EVA activities on the International Space Station. | 26 |
| 5.1-1 | A general EVA roadmap for HTCI to support similar advanced EVA programs of the type envisioned for this study. | 42 |
| A.1-1 | Functional breakdown for the integrated EVA system. | 49 |
| A.2-1 | Functional breakdown for the human operated external work system. | 50 |
| A.3-1 | Functional breakdown for the human operated internal work system. | 50 |
| A.4-1 | Functional breakdown for the transportation system. | 51 |
| A.5-1 | Functional breakdown for the support infrastructure system. | 52 |
| A.6-1 | Functional breakdown for the ground-based support systems. | 52 |
| B.1-1 | Wiley Post and his pressurized flying suit. | 54 |
| B.1-2 | Project Mercury pressure suit. (NASA Photo) | 56 |
| B.1-3 | Ed White on first U.S. EVA. (NASA Photo) | 56 |
| B.1-4 | The Apollo A7L-B suit. | 57 |
| B.1-5 | General view of the Space Shuttle EMU. | 58 |
| B.1-6 | Apollo EVA glove assembly. | 59 |
| B.1-7 | The Apollo PLSS showing the OPS, the PLSS, and the Remote Control Unit. | 60 |
| B.1-8 | The Berkut EVA suit used by A. Leonov. | 61 |

| Figure Number | | Page |
|--------------------------|---|-------------|
| B.1-9 | The Orlan DM EVA suit. | 62 |
| B.1-10 | The SPK maneuvering unit, designed for use with the Orlan-DMA suit. | 63 |
| B.1-11 | Some commonly used EVA tools, showing the special modifications incorporated for the special circumstances of working in the EVA environment. | 64 |
| B.2-1 | The Shuttle Remote Manipulator System with its various elements indicated. | 65 |
| B.3-1 | Ed White on the first American EVA, using the Handheld Maneuvering Unit. | 66 |
| B.3-2 | AMU as configured for Gemini 9. | 67 |
| B.3-3 | A Skylab 3 onboard photo shows astronaut Jack Lousma as he flew the M509 AMU in the forward dome of Skylab while in Earth orbit. | 68 |
| B.3-4 | Astronaut Bruce McCandless makes the first untethered free flight using the MMU. | 68 |
| B.3-5 | The Apollo 14 astronauts used this prototype of the MET during their geological and lunar surface simulation training in the Pinacate volcanic area of northwestern Sonora, Mexico. | 69 |
| B.3-6 | The LRV deployed on the lunar surface. | 70 |
| B.4-1 | The Voskhod spacecraft (minus the service module) with the inflatable airlock deployed. Note head and shoulders of a suited crewmember at the top of the airlock. | 71 |
| B.4-2 | Salyut 6: 1977–1982. In this image, the airlock portion of the station is located at the upper right. | 72 |
| B.4-3 | <i>Mir</i> space station as configured in late 1989/early 1990. | 73 |
| B.4-4 | A model of the Buran space shuttle. The airlock is located at the upper end of the payload bay. | 74 |
| B.4-5 | Buran airlock. | 74 |
| B.4-6 | Cutaway view of the Apollo-Soyuz Test Project docking module and major subsystems. The Apollo Command Module docks at the right end in this view; the Soyuz docks at the left. | 78 |
| B.4-7 | Cutaway view of the interior of the Skylab Airlock Module. | 79 |
| B.4-8 | The Shuttle Airlock. This image includes an EVA suited crewmember to indicate size. It also indicates the general placement of hatches and controls/EVA hookups. | 79 |

| Figure Number | | Page |
|--------------------------|---|-------------|
| B.4-9 | Space Shuttle Endeavor docked to the International Space Station during the STS 113 mission. (NASA image STS113-308-002) | 80 |
| B.5-1 | Apollo 13 astronaut Fred Haise during lunar surface simulation training. (NASA photo S70-24009) | 81 |
| B.5-2 | Activities on 5 January 1972 during a simulation of film retrieval from the Apollo Telescope Mount (Skylab) in the Marshall Space Flight Center Neutral Buoyancy Simulator. | 81 |
| B.5-3 | STS-37 crewmembers train for a planned EVA in JSC's WETF. (NASA photo S89-50846) | 82 |
| B.5-4 | EVA training at Star City. | 82 |
| B.5-5 | A typical parabolic flight profile used to simulate a reduced-gravity environment. | 83 |
| B.5-6 | Astronaut Alan Shepard (Apollo 14) with Modular Equipment Transporter aboard KC-135. (NASA photo S70-53479) | 83 |
| B.5-7 | Chamber A showing the 12.2 m diameter access door in the open position. Note test personnel standing just below the access opening for scale. | 84 |
| B.5-8 | Line drawing of Chamber B in the Thermal Vacuum Test Complex. | 85 |
| B.5-9 | Apollo 11 crewmembers participates in a rehearsal of EVA activities on a simulation of the Moon's surface constructed at the Manned Spacecraft Center. (NASA photo S69-32243) | 86 |
| B.5-10 | Apollo 13 astronauts participate in walk-through of EVA timeline at KSC. (NASA photo S70-29672) | 86 |
| B.5-11 | Apollo 15 crewmen riding lunar roving vehicle simulator during geology trip at the Cinder Lake crater field near Flagstaff, Arizona. (NASA photo S70-53300) | 86 |
| B.5-12 | Astronauts Lovell and Haise during simulation of lunar traverse at Kilauea, Hawaii. (NASA photo S70-20253) | 87 |
| B.5-13 | Members of Apollo 15 crew collect soil samples during simulated EVA near Taos, New Mexico. (NASA photo S71-23772) | 87 |
| B.5-14 | View of Medical Support Room in Mission Control Center during Apollo 16. (NASA photo S72-35460) | 87 |
| B.5-15 | Seismometer readings studied in Mission Control Center. (NASA photo S71-41422) | 88 |

| Figure Number | | Page |
|--------------------------|--|-------------|
| B.5-16 | JSC Life Sciences Control Center. | 88 |
| C.1-1 | The U.S. EMU, illustrating some of the major components. | 90 |
| C.1-2 | Soft goods layers making up the Shuttle EMU Space Suit Assembly. | 91 |
| C.1-3 | The 4000 Series glove assembly. | 92 |
| C.1-4 | The Phase VI glove assembly. | 93 |
| C.1-5 | The Shuttle EMU Primary Life Support System showing the five major groups of components. | 95 |
| C.1-6 | The secondary oxygen pack with its various components illustrated. | 96 |
| C.1-7 | An illustration of the Display and Control Module and its various components. | 97 |
| C.1-8 | Orlan-M space suit. | 99 |
| C.1-9 | The Orlan Oxygen Supply System. | 100 |
| C.1-10 | The Orlan Thermal Control System schematic. | 102 |
| C.1-11 | Space Suit Electrical Console. | 103 |
| C.1-12 | The D-1 (S1035X) experimental suit developed by the David-Clark Company. | 104 |
| C.1-13 | The H-1 or Mark III experimental EVA suit developed from a variety of NASA in-house components. | 105 |
| C.1-14 | The I-1 experimental EVA suit developed by the ILC Corporation. | 105 |
| C.1-15 | “Foam” advanced PLSS concept. | 106 |
| C.1-16 | “Motherboard” advanced PLSS concept. | 106 |
| C.1-17 | “LEGO™” advanced PLSS concept. | 106 |
| C.2-1 | The Space Station Remote Manipulator System, or SSRMS. (Image courtesy of the Canadian Space Agency.) | 109 |
| C.2-2 | A general view of the Mobile Servicing System, including the Mobile Base System and the Special Purpose Dexterous Manipulator. (Image courtesy of the Canadian Space Agency) | 109 |
| C.2-3 | The Japanese Experiment Module with its associated Exposed Facility and Remote Manipulator System. (Image courtesy of NASDA) | 110 |
| C.2-4 | AERCam Sprint during its orbital flight demonstration on STS- | 111 |

| Figure Number | | Page |
|--------------------------|--|-------------|
| | 87. (NASA image STS087-752-035) | |
| C.2-5 | Mini AERcam. (NASA image) | 112 |
| C.2-6 | The ERA in a field exercise with a test subject wearing the Mark III experimental EVA garment. (NASA photo) | 113 |
| C.2-7 | A neutral buoyancy test of Ranger mounted on a Spacelab Pallet mock-up. (UMSSL photo) | 114 |
| C.2-8 | The Robonaut system. (NASA photo) | 115 |
| C.3-1 | The deployment and attachment of the SAFER to the U.S. EMU. | 116 |
| C.3-2 | The CETA cart with toolbox attached (at lower right in this image). | 117 |
| C.3-3 | The ISS Joint Airlock Module. | 118 |
| C.4-1 | Advanced mechanical counter-balance – the Partial Gravity Counterbalance System. | 120 |
| C.4-2 | A view of a full-scale Shuttle cargo bay mock-up and other training aids in the NBL. (NASA photo S9716086) | 120 |
| C.4-3 | The octagon-shaped NBF Pool. The preparation platform is in foreground and rolled up pool cover in background. (Photo courtesy of ESA) | 121 |
| C.4-4 | The NASDA neutral buoyancy facility with a full-scale mock-up of the Kibo module destined for the International Space Station. (NASDA photo) | 122 |
| C.4-5 | The deck area of the NBRF. In the tank is a mock-up of a section of the ISS main truss. (UMD photo) | 122 |
| C.4-6 | A comparison of the physical sizes of the Airbus A-300, Boeing KC-135 and Ilyushin IL-76. | 123 |
| C.4-7 | Astronaut Jerry Ross uses virtual reality EVA training in the VR Laboratory as part of the preparation for STS-88. (NASA photo s98-05079) | 124 |
| C.4-8 | “INTEGRITY” plan view in the facility that formerly housed the JSC centrifuge and WETF. | 125 |
| C.4-9 | Testing the deployment of a solar array at Cinder Lake, Arizona. (NASA photo) | 126 |
| C.4-10 | A view of the JSC “rock yard” EVA system testing facility. (NASA photo) | 126 |
| C.4-11 | A scale model of an expanded version of the JSC “rock yard” | 127 |

| Figure Number | | Page |
|--------------------------|---|-------------|
| | testing facility. | |
| C.4-12 | The “white” Flight Control Room in the new Mission Control Center. (NASA photo) | 127 |
| C.4-13 | The Exploration Planning and Operations Center in the new Mission Control Center. (NASA photo) | 128 |
| C.4-14 | FutureFlight Central at the NASA Ames Research Center. (NASA photo) | 128 |
| C.4-15 | EVA field tests conducted over the past five years at various locations in the southwest United States. | 129 |
| E-1 | The Annis-Webb mechanical counter pressure suit concept from the 1960s. | 139 |
| E-2 | A mechanical counter pressure concept put forward by Honeywell. | 139 |
| E-3 | A cross-sectional view of the layers used in the Chameleon suit to give it the capability of active thermal control. | 140 |
| E-4 | At left, a single-person EVA spacecraft developed during the 1950’s as part of a larger space development concepts put forward by W. von Braun and others. At center, a single-person EVA spacecraft developed for the movie <i>2001 A Space Odyssey</i> in 1968 (MGM Pictures). At right, a single-person spacecraft using three manipulators – one to maintain position and two others to manipulate objects. | 142 |
| E-5 | One example of an unpressurized rover capable of carrying two crew and additional equipment. (NASA image) | 142 |
| E-6 | An unpressurized rover equipped with a small drill powered by the rover’s power plant and energy supply. (NASA image) | 143 |
| E-7 | One possible implementation of a “dustlock” that would be used for managing the introduction of dust into a habitat, as well as minimizing its infiltration into an EVA garment. (NASA image) | 144 |
| E-8 | A cross section view of the suitport concept. (M. Cohen, from U.S. Patent 4,842,224) | 145 |

ACRONYMS AND ABBREVIATIONS

| | |
|--------|--|
| ACCESS | Assembly Concept for Construction of Erectable Space Structures |
| ADD | Aerospace Design and Development |
| AERCam | Autonomous Extravehicular Robotic Camera |
| ALSS | Autonomous Life Support System |
| AMU | Astronaut Maneuvering Unit |
| | |
| CAD | computer aided design |
| CB | Office code of the Astronaut Office at the NASA Johnson Space Center |
| CD | compact disk |
| CETA | Crew and Equipment Translation Aid |
| cm | centimeter |
| CMOS | Complementary Metal-Oxide Semiconductor |
| CNC | Computer Numerical Control |
| CORBA | Common Object Request Broker Architecture |
| | |
| DARPA | Defense Advanced Research Projects Agency |
| DART | Dual Anamorphic Reflector Telescope |
| DCM | Display and Control Module |
| DOF | degrees of freedom |
| DRM | Design Reference Mission |
| | |
| EASE | Experimental Assembly of Structures through EVA |
| EH | Electrical Harness |
| EKG | electrocardiogram |
| EMU | Extravehicular Mobility Unit |
| ERA | EVA Robotic Assistant |
| ESA | European Space Agency |
| EVA | extravehicular activity |
| | |
| FAIR | Filled Aperture Infrared (telescope concept) |
| FFC | FutureFlight Central |
| ft | foot |
| | |
| GPS | Global Positioning System |
| | |
| HEDS | Human Exploration and Development of Space |
| HHMU | hand held maneuvering unit |
| HHSMU | hand held self maneuvering unit |
| HTCI | HEDS Technology/Commercialization Initiative |
| HUT | hard upper torso |
| | |
| IAI | Intelligent Automation, Inc. |
| ILC | International Latex Corporation |

| | |
|-----------|--|
| in. | inch |
| INTEGRITY | Integrated Human Exploration Mission Simulation Facility |
| ISS | International Space Station |
| IVA | intravehicular activity |
| JAM | Joint Airlock Module |
| JEM | Japanese Experiment Module |
| JEM RMS | JEM Remote Manipulator Systems |
| JSC | Johnson Space Center |
| kbtu | kilo-British thermal units |
| kg | kilogram |
| km | kilometer |
| kPa | kilo Pascals |
| kW | kilo-Watt |
| kWe | kilo-Watt, electric |
| LaRC | Langley Research Center |
| lb | pounds |
| LCVG | liquid cooling and ventilation garment |
| LExSWG | Lunar Exploration Science Working Group |
| LEO | low Earth orbit |
| LM | lunar module |
| LRU | line replaceable unit |
| LRV | Lunar Rover Vehicle |
| m | meter |
| MET | Modular Equipment Transporter |
| MMOD | micrometeoroid and orbital debris |
| MMU | Manned Maneuvering Unit |
| mph | miles per hour |
| MSC | Manned Spacecraft Center (former name of the Johnson Space Center) |
| NASA | National Aeronautics and Space Administration |
| NASDA | National Space Development Agency (Japan) |
| NBF | Neutral Buoyancy Facility (ESA) |
| NBL | Neutral Buoyancy Laboratory (NASA) |
| NBRF | Neutral Buoyancy Research Facility (University of Maryland) |
| NBS | Neutral Buoyancy Simulator (NASA) |
| NEAR | Near Earth Asteroid Rendezvous |
| NEXT | NASA Exploration Team (also used is the acronym NEXT) |
| NGS | Next Generation Suit |
| NGST | Next Generation Space Telescope |
| NRC | National Research Council |
| OPS | Oxygen Purge System |

| | |
|---------|---|
| ORU | orbital replacement unit |
| OTD | ORU Transfer Device |
| PGCS | Partial Gravity Counterbalance System |
| PLSS | portable life support system or primary life support system |
| psi | pounds per square inch |
| RAF | Royal Air Force |
| RASC | Revolutionary Aerospace Systems Concepts Program |
| RCAF | Royal Canadian Air Force |
| RMS | Remote Manipulator System |
| rpm | revolutions per minute |
| SAFER | Simplified Aid for Extravehicular Activity Rescue |
| SAS | Space Activity Suit |
| SELENE | SELenological and ENgineering Explorer (Japanese lunar robotic mission) |
| SMART-1 | Small Missions for Advanced Research and Technology (EVA lunar robotic mission) |
| SOTA | state of the art |
| SPK | <i>Sredstvo Peredvizheniy Kosmonavtov</i> (“Cosmonaut Maneuvering Equipment”) |
| SRU | shop replaceable unit |
| SSA | space suit assembly |
| SSRMS | Space Station Remote Manipulator System |
| STS | Space Transportation System |
| TBD | to be determined |
| TRL | technology readiness level |
| TsUP | <i>Tsentr Upravleniya Polyotami</i> (Soviet/Russian flight control center) |
| UMSSL | University of Maryland Space Systems Laboratory |
| U.S. | United States |
| USGS | United States Geographical Survey |
| WBS | Work Breakdown Structure |
| WEFT | Weightless Environment Training Facility (NASA) |

EXECUTIVE SUMMARY

This report documents the results of a study carried out as part of NASA's Revolutionary Aerospace Systems Concepts (RASC) Program examining the future technology needs of extravehicular activities (EVAs).

The intent of this study is to produce a comprehensive report that identifies various design concepts for human-related advanced EVA systems necessary to achieve the goals of supporting future space exploration and development customers in free space and on planetary surfaces for space missions in the post-2020 timeframe. The design concepts studied and evaluated are not limited to anthropomorphic space suits, but include a wide range of human-enhancing EVA technologies as well as consideration of coordination and integration with advanced robotics.

The goal of the study effort is to establish a baseline technology "road map" that identifies and describes an investment and technical development strategy, including recommendations that will lead to future enhanced synergistic human/robot EVA operations. The eventual use of this study effort is to focus evolving performance capabilities of various EVA system elements toward the goal of providing high-performance human operational capabilities for a multitude of future space applications and destinations.

Study Approach

The approach used for this study follows the basic RASC study steps, tailored to this particular effort. First the NASA Strategic Plan and the NASA Enterprises, in particular the former HEDS Enterprise, were reviewed for their objectives and priorities for the next 25 years. These sources were used as primary guidance for missions and capabilities during this period. This vision of the future was described in the form of several "reference missions" carried out at a number of locations in the solar system. From these reference missions, a set of functional capabilities and high-level mission requirements was extracted. In the next step, an integrated EVA architecture was defined in terms of a work breakdown structure (WBS)-like structure, encompassing not only the traditional elements of an EVA system, the space suit and life support, but also all of the other systems needed for an EVA activity. The reference missions plus lessons learned from EVAs carried out to date were used to augment the functional capabilities and mission requirements for the EVA architecture. These capabilities and requirements were assigned to the appropriate WBS element. Third, both the historical and current state of the art for EVA systems was reviewed to define a starting point for the desired EVA roadmap. A variety of sources, including a solicitation from those working in the advanced EVA community, was then consulted to identify a number of system concepts that could fulfill future EVA functional requirements. These concepts were grouped according to the WBS structure defined in the second step of this process. In the fourth step, the current state of the art (the beginning point for the desired roadmap) for various systems was compared with EVA system roadmaps that have already been developed. Necessary updates to these roadmaps were noted and various alternative additions were developed to fill gaps as well as expand the entire roadmap out to the 25-year milestone. In the last step, recommendations are made for a roadmap consistent with knowledge of EVA needs in this future timeframe. Along with this roadmap are suggestions for technology investments that should be made to realize the capabilities identified in the roadmap.

Study Results and Recommendations

The data collected for this study indicate a rich and diverse history of systems that have been developed to perform a variety of EVA tasks, indicating what is possible. However, the data gathered for this study also indicate a paucity of new concepts and technologies for advanced EVA missions—at least any that researchers are willing to discuss in this type of forum. As indicated by one of the respondents to the e-mail solicitation sent to those working in this field, *“EVA system concepts are driven largely by mission design requirements and thus are the most difficult to define for a generic mission.”* The seeds for this conclusion are traceable to NASA’s future objectives as stated in its Strategic Plan—the starting point for this study.

Without *definite objectives* and a *timeframe* for accomplishing them, then the only approach may be to spread what resources are available across the broadest possible portfolio of technology options and concepts. This will at least allow limited progress to be made across a range of technologies and systems that may support some (or many) of the general destination and timeframe options that could result from choices made regarding the NASA Strategic Plan. Focusing too narrowly on any particular suite of technologies, given the lack of an equally focused set of destinations, missions, and a timetable, risks expending valuable resources on the wrong solution. Spreading resources across a broad range of technologies will, however, assuredly slow progress for any particular technology, but conversely this will also improve the chances of achieving a breakthrough in some technology. The predictability of a breakthrough in any one particular technology, regardless of the magnitude of resources devoted to it, is generally difficult if not impossible. But it is predictable that breakthrough, or revolutionary, technologies do require resources to occur at all. Unfortunately, only very small amounts of resources have been dedicated, recently, to advancing EVA concepts of any kind.

Revolutionary advances are not always made up solely of breakthroughs or radical changes. To accomplish the vision outlined in the early stages of this study will require a suite of technological and operational advances that can accomplish the following:

- Completing within a single mission (a representative Mars mission) an equivalent number of EVA sortie hours as have been completed in all of the previous 40 years of EVA activity, while this single mission will require less than one tenth (i.e., less than four years) of that time to complete.
- Improvements in both maintenance techniques and system reliability that will increase by an order of magnitude the number of sorties allowed for EVA systems in nominal operations.
- Cutting the mass of an EVA suit (garment and portable life support system) by at least a factor of 2 to 3, compared to current systems while retaining the same (or improved) functional capabilities.
- Increasing the range at which EVA activities are conducted away from a habitat (or equivalent safe location) by at least an order of magnitude over the best previous experience of the Apollo J series missions.

This capability will be accomplished through a combination of: (1) emerging or revolutionary technologies, (2) evolutionary advances in existing technologies, (3) methodical testing through all stages of system development, and (4) development of operational concepts that utilize the

best features these systems have to offer. But progress toward success or failure of all of these factors can only be measured against a set of requirements to be met. At the present time, NASA's requirements for future EVA are very broad and generic. As a consequence, perhaps the best use of the results obtained from this study would be to construct a set of guidelines, or figures of merit, against which to compare any particular proposed technology or system concept, and to prepare a sequencing of the functional needs derived from the Strategic Plan. Both of these would be described at a level that is consistent with the goals, objectives, and requirements of the NASA Strategic Plan.

Consequently, the following features should guide forward progress for advanced EVA development, consistent with the data gathered for this study and the current set of NASA mission objectives, destinations, and timetable for their completion:

- A suite of systems with the functional capabilities and performance for all elements in the EVA functional breakdown structure, as described in Table 3.4-1.
- The general sequence in which these systems are needed is: a lightweight, mobile (i.e., capable of walking) suit system (garment plus primary life support system, or PLSS), environment-specific surface systems (airlocks, rovers, navigation/communication/safe haven), and robotic support systems.
- All systems should be designed with an open architecture and with modular components, to the maximum extent possible, to allow the systems to be used for extended lifetimes and to accommodate progressive upgrades.
- All systems should be compatible across all of the environments described, to the maximum extent possible.
- Systems should be certified in a progressive manner for on the order of 50 days, then on the order of 500 days of use independent of Earth-based support.

Report Organization

This report is divided into five main sections. Section 2 describes a vision of the next 25 years from the perspective of the NASA Enterprises along with the functional capabilities and mission requirements that can be derived from them. This defines the “future” end of the EVA technology roadmap. Section 3 describes the beginning of the EVA technology roadmap by looking at the current state of the art for EVA. This includes looking back at historical systems that also indicate what has been accomplished but which may now be dormant. The diversity of systems associated with EVA, for not only operations but development, requires a functional organizational structure for these systems to provide a basis for discussing their evolution and future development. Thus this section describes a structure for the major functional components of the EVA system as it is used in this report. These components are grouped in a WBS-like format, the details of which are contained in Appendix A. This section also discusses relevant EVA “lessons learned,” primarily those from the Apollo program. (A more detailed discussion of the Apollo lessons is in Appendix B.) Section 3 concludes with a set of augmented capabilities and requirements, assigned to the appropriate element of the EVA system. Section 4 describes revolutionary EVA system concepts for various elements of the WBS defined in Section 3. This includes results from a solicitation of concepts from the EVA community as well as concepts gathered from various other public sources. Section 5 synthesizes the information described in Section 4 to derive a roadmap that builds on existing relevant roadmaps to meet the vision of the

future described in Section 2. Section 6 summarizes the report and provides recommendations for the next steps in this process. The report concludes with references and a series of appendices containing supplemental information, including a bibliography of relevant future EVA sources.

A unique feature of this report is the inclusion of both still and animated illustrations of some of the future concepts envisioned for EVA and supporting components. For the animations to be viewed, this report must be viewed from the CD version on a computer supporting QuickTime™ (version 5 or later) or compatible viewing software. Figure captions will indicate when a particular illustration is animated.

1.0 INTRODUCTION

1.1 Overview

This report documents the results of a study carried out as part of NASA's Revolutionary Aerospace Systems Concepts (RASC) Program examining the future technology needs of extravehicular activities (EVAs).

The intent of this study is to produce a comprehensive report that identifies various design concepts for human-related advanced EVA systems necessary to achieve the goals of supporting future space exploration and development customers in free space and on planetary surfaces for space missions in the post-2020 timeframe. The design concepts studied and evaluated are not limited to anthropomorphic space suits, but include a wide range of human-enhancing EVA technologies as well as consideration of coordination and integration with advanced robotics.

The goal of the study effort is to establish a baseline technology "road map" that identifies and describes an investment and technical development strategy, including recommendations that will lead to future enhanced synergistic human/robot EVA operations. The eventual use of this study effort is to focus evolving performance capabilities of various EVA system elements toward the goal of providing high-performance human operational capabilities for a multitude of future space applications and destinations.

1.2 The RASC Program

The key objectives of the RASC Program are to develop aerospace systems concepts and technology requirements to enable future NASA missions (see The RASC Vision, Figure 1.2-1). The RASC Program applies a "top-down" perspective to explore new mission capabilities and discover "what's possible." By accomplishing these objectives, NASA will provide the concepts and technologies that can make it possible to "go anywhere, at anytime, safely, reliably, and affordably." The RASC Program is focused on making significant strides in accomplishing NASA's strategic goals for science, exploration, and commercialization. This Program seeks to maximize the benefits of revolutionary capabilities that span across NASA Strategic Enterprises as it defines the technology requirements and the performance criteria to meet these challenges.

The initial focus of the RASC Program is developing revolutionary systems concepts that represent missions from the runway to the planets. The evaluation of these concepts will enhance the definition of enabling technology requirements and payoffs for future mission capabilities. These results are then delivered to the respective NASA Enterprises and the NASA Chief Technologist for planning the investments to accomplish future revolutionary research and technology goals.

To achieve the NASA strategic goals and objectives, the RASC Program focuses on revolutionary vehicle and operations concepts that will make previously impractical aerospace missions possible. A "top-down" methodology, using the following key steps, is used as a starting point for RASC studies:

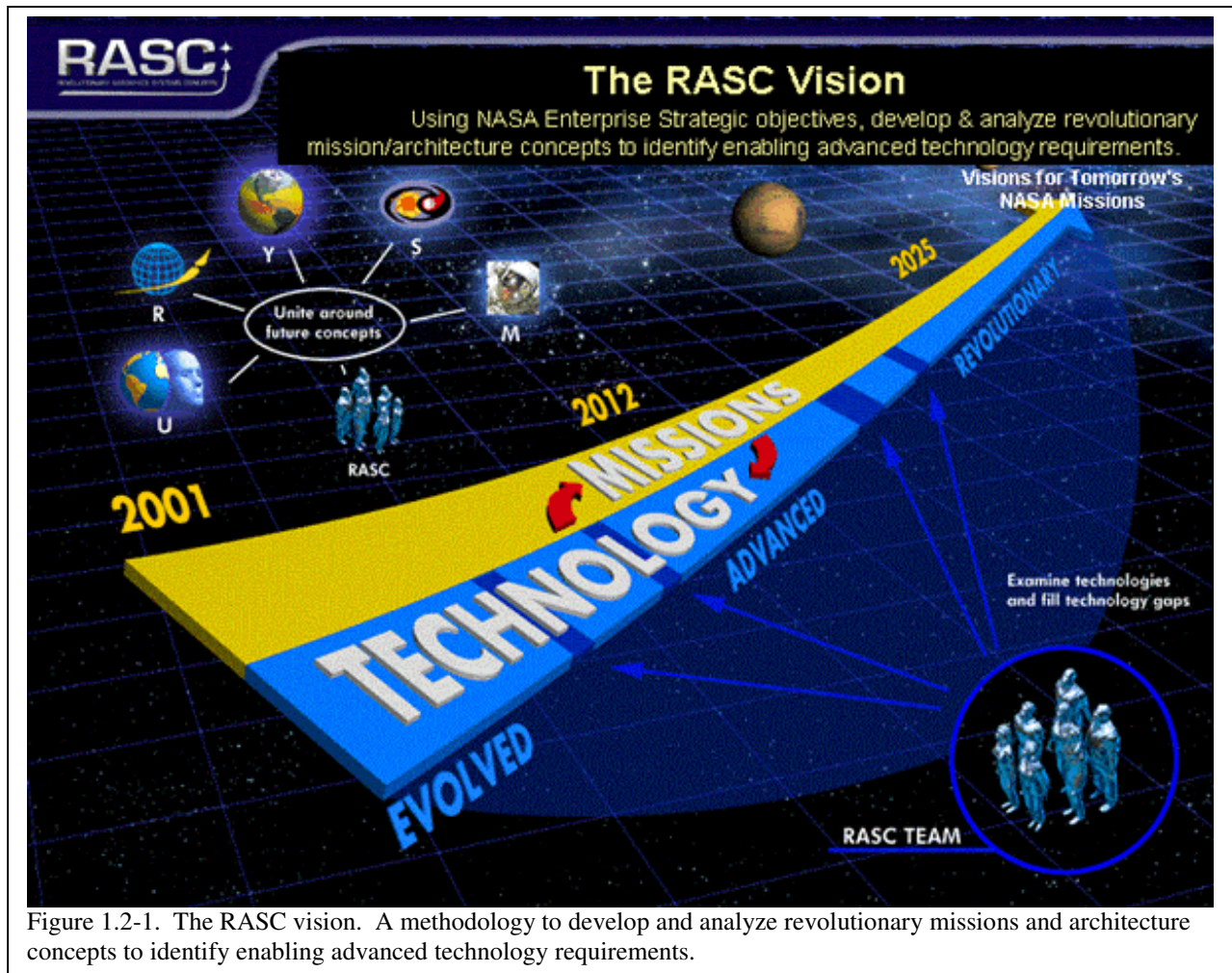

Figure 1.2-1. The RASC vision. A methodology to develop and analyze revolutionary missions and architecture concepts to identify enabling advanced technology requirements.

- Using a 25-year vision perspective, identify the desired new capabilities derived from NASA Enterprise objectives and priorities;
- Define integrated systems approaches (architectures) and their required functional capabilities or engineering challenges;
- Develop revolutionary systems concepts to provide these capabilities;
- Conduct systems trade studies to define the enabling technology requirements and levels of performance needed to meet the challenges; and
- Recommend the most promising revolutionary concepts with their integrated system payoffs and key enabling technology requirements.

The NASA Headquarters Office of Aerospace Technology manages the RASC Program and reports results to the NASA Chief Technologist and the NASA Enterprises. The Langley Research Center (LaRC) Aerospace Systems Concepts and Analysis Competency leads the RASC Program. The RASC Program includes the experts from the NASA field centers, contributors from industry, universities, and special consultants.

1.3 Study Approach

The approach used for this study follows the basic RASC study steps described above, tailored to this particular effort and illustrated in Figure 1.3-1, shown below. First the NASA Strategic Plan and the NASA Enterprises, in particular the former Human Exploration and Development of Space (HEDS) Enterprise, were reviewed for their objectives and priorities for the next 25 years. These sources were used as primary guidance for missions and capabilities during this period. This vision of the future was described in the form of several “reference missions” carried out at a number of locations in the solar system. From these reference missions, a set of functional capabilities and high-level mission requirements were extracted. In the next step, an integrated EVA architecture was defined in terms of a WBS-like structure, encompassing not only the traditional elements of an EVA system, the space suit and life support, but also all of the other systems needed for an EVA activity. The reference missions plus lessons learned from EVAs carried out to date were used to augment the functional capabilities and mission requirements for the EVA architecture. These capabilities and requirements were assigned to the appropriate WBS element. Third, both the historical and current state of the art for EVA systems were reviewed to define a starting point for the desired EVA roadmap. A variety of sources, including a solicitation from those working in the advanced EVA community, were then consulted to identify a number of system concepts that could fulfill future EVA functional requirements. These concepts were grouped according to the WBS structure defined in the second step of this process.

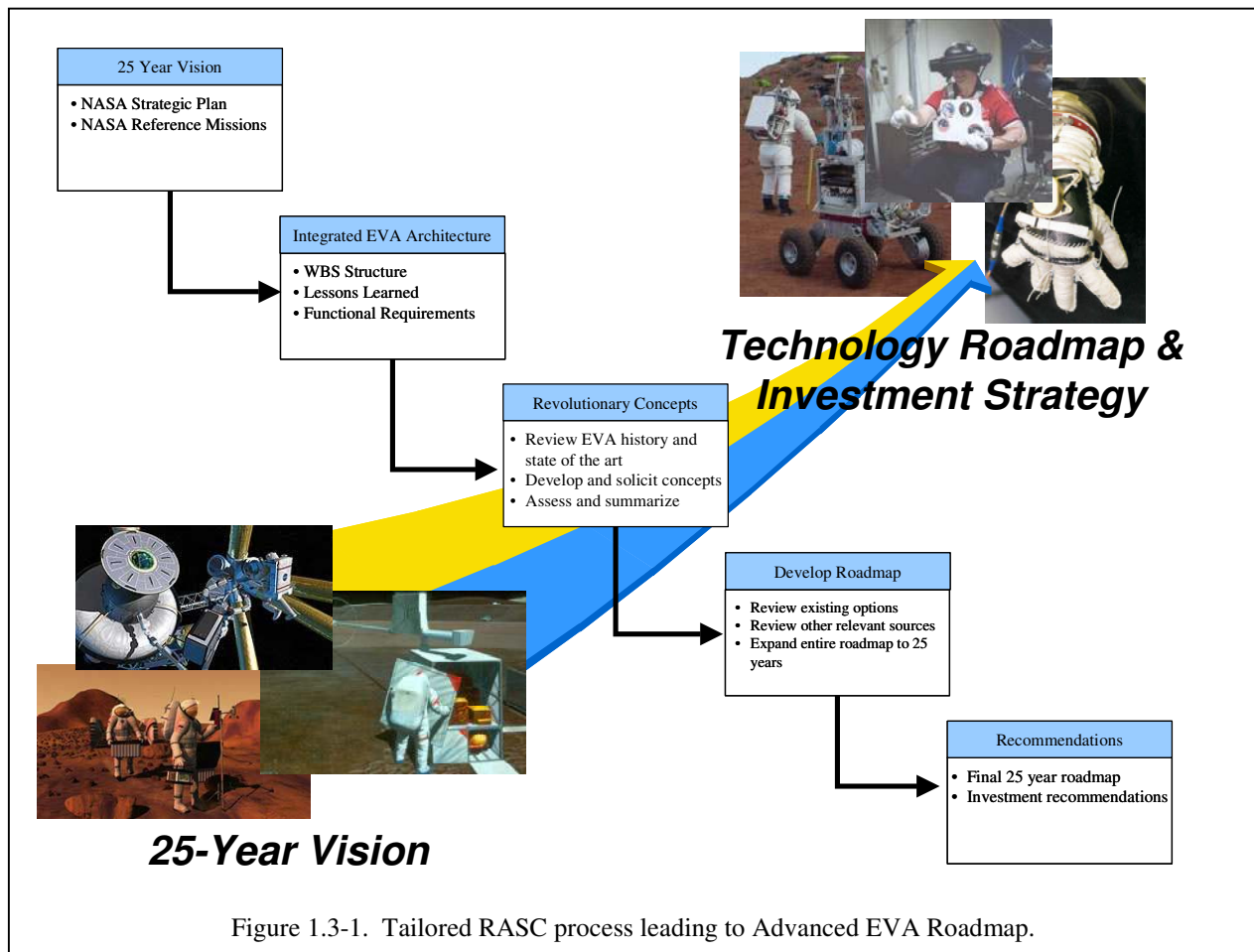

Figure 1.3-1. Tailored RASC process leading to Advanced EVA Roadmap.

In the fourth step, the current state of the art (the beginning point for the desired roadmap) for various systems was compared with EVA system roadmaps that have already been developed. Necessary updates to these roadmaps were noted and various alternative additions were developed to fill gaps as well as expand the entire roadmap out to the 25-year milestone. In the last step, recommendations are made for a roadmap consistent with knowledge of EVA needs in this future timeframe. Along with this roadmap are suggestions for technology investments that should be made to realize the capabilities identified in the roadmap.

1.4 Report Outline

The remainder of this report is divided into five main sections. Section 2 describes a vision of the next 25 years from the perspective of the NASA Enterprises along with the functional capabilities and mission requirements that can be derived from them. This defines the “future” end of the EVA technology roadmap. Section 3 describes the beginning of the EVA technology roadmap by looking at the current state of the art for EVA. This includes looking back at historical systems that also indicate what has been accomplished but which may now be dormant. The diversity of systems associated with EVA, for not only operations but development, requires a functional organizational structure for these systems to provide a basis for discussing their evolution and future development. Thus this section describes a structure for the major functional components of the EVA system as it is used in this report. These components are grouped in a WBS-like format, the details of which are contained in Appendix A. This section also discusses relevant EVA “lessons learned,” primarily those from the Apollo program. (A more detailed discussion of the Apollo lessons is in Appendix B.) Section 3 concludes with a set of augmented capabilities and requirements, assigned to the appropriate element of the EVA system. Section 4 describes revolutionary EVA system concepts for various elements of the WBS defined in Section 3. This includes results from a solicitation of concepts from the EVA community as well as concepts gathered from various other public sources. Section 5 synthesizes the information described in Section 4 to derive a roadmap that builds on existing relevant roadmaps to meet the vision of the future described in Section 2. Section 6 summarizes the report and provides recommendations for the next steps in this process. The report concludes with references and a series of appendices containing supplemental information, including a bibliography of relevant future EVA sources.

A unique feature of this report is the inclusion of both still and animated illustrations of some of the future concepts envisioned for EVA and supporting components. For the animations to be viewed, this report must be viewed from the CD version on a computer supporting QuickTime™ (version 5 or later) or compatible viewing software. Figure captions will indicate when a particular illustration is animated.

2.0 A VISION OF THE FUTURE OF EVA AND EVA SYSTEMS

The first step in building this advanced EVA roadmap is to construct a vision of the future, approximately 25 years from now, of human space exploration and the uses of EVA in that future. To be of use in the RASC process, this vision must describe destinations, missions, and activities from which functional requirements can be derived. These functional requirements serve to define one end of the desired technology development roadmap.

This section begins with a discussion of the NASA Strategic Plan for future exploration activities, focusing on guidance and direction it provides for developing this vision of future EVA. Several different future mission scenarios based on this guidance are then described at a level of detail from which functional requirements can be derived. Each of these mission descriptions is accompanied by several visualizations, both still and animated, to help describe the EVA activities associated with each mission. This includes possible system implementations that may or may not be implemented. Finally, these functional requirements are explicitly stated and organized for use in later phases of this roadmap development.

2.1 NASA's Strategic Plan

Creating a vision of the future 25 years from now could evolve along a vast number of different pathways, all equally viable given no other guidance or constraints. However, NASA has developed a strategic plan for the express purpose of providing "...long-term direction for all of our activities" (NASA, 2003). NASA's Mission Statement, as expressed in the Strategic Plan, contains three components:

- To understand and protect our home planet
- To explore the universe and search for life
- To inspire the next generation of explorers

With these guiding principles in mind, the Agency is developing an integrated exploration strategy to direct NASA's future investments. These investments are intended to result in "building-block capabilities" that will steadily increase "our ability to conduct ever more challenging robotic and human missions."

To "provide the context for planning and program development," seven strategic goals were developed "... that outline what NASA will achieve in the coming decades ..." for each component of this Mission Statement. An additional three "enabling" goals were established in areas critical to the achievement of the seven strategic goals. One of these enabling goals (Number 9 as enumerated in the Strategic Plan) provides the specific rationale and context for developing this long-term EVA roadmap:

- Extend the duration and boundaries of human spaceflight to create new opportunities for exploration and discovery.

Although these enabling goals are implicitly designed to support the other seven strategic goals, the Strategic Plan also explicitly describes the role future human missions (including EVA) should play in achieving the Agency's strategic goals:

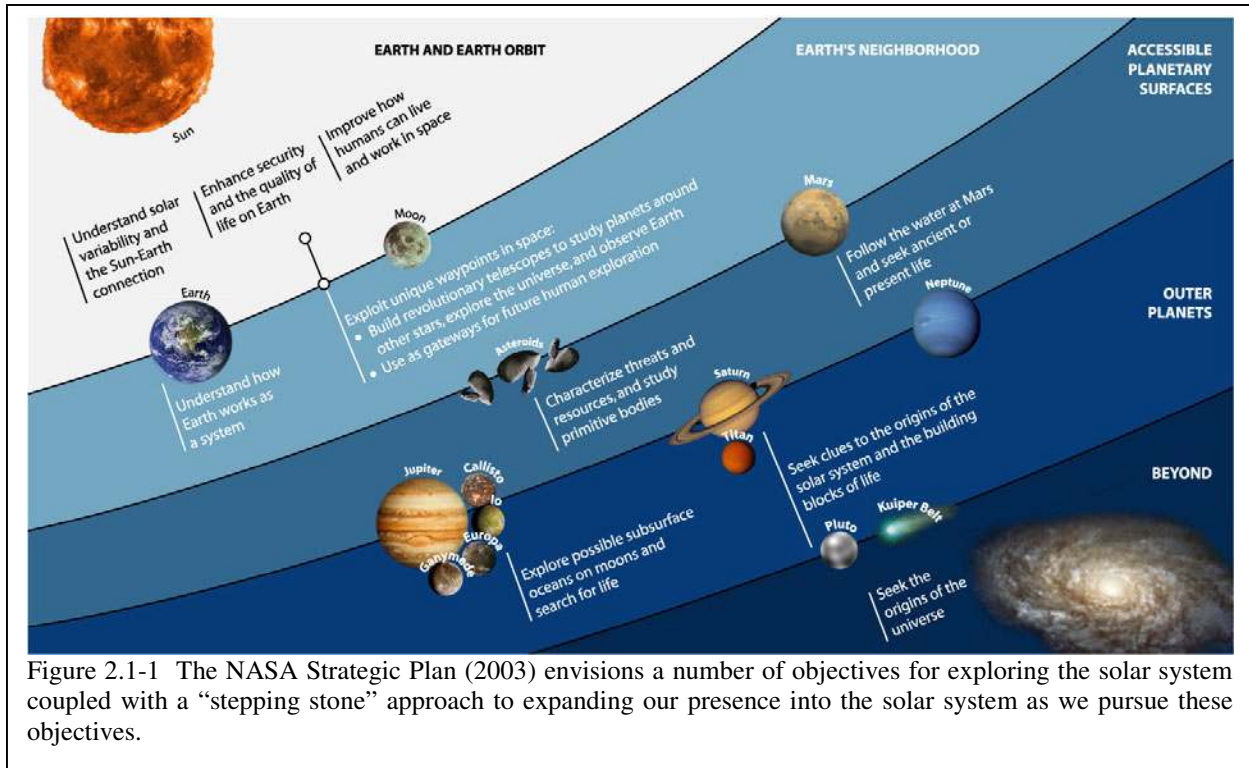

Figure 2.1-1 The NASA Strategic Plan (2003) envisions a number of objectives for exploring the solar system coupled with a “stepping stone” approach to expanding our presence into the solar system as we pursue these objectives.

“The capabilities we develop will eventually enable humans to construct and service science platforms at waypoints in space between Earth and the Sun. Someday, we may use those same waypoints to begin our own journeys into the solar system to search for evidence of life on Mars and beyond.”

Thus, these key thoughts from NASA’s Strategic Plan—

- Extend the duration and boundaries of human spaceflight
- Building block capabilities
- Support for all three components of NASA’s Mission Statement
- Construction and servicing of science platforms
- Future missions to Mars and beyond
- Ever more challenging robotic and human missions

—provide the guidance needed to develop a vision of EVA activities 25 years in the future and, in so doing, contribute to NASA’s overall plan for strategic investments in technology development. NASA has not committed to a specific timetable or sequence of destinations for human space missions that will occur after those missions planned for the International Space Station (ISS), currently scheduled to be completed within this decade and with planned missions extending past 2010. Thus, a vision of the future 25 years hence must include human EVA activities in free space, on the Moon, on Mars, and beyond Mars, but in a sequence that has yet to be determined. The following narrative describes such a broad vision, but as a series of discrete missions that do not rely on any specific sequencing.

2.2 Future Human Exploration Missions

A planning mission or a reference mission, sometimes referred to as a Design Reference Mission (DRM), is a tool used by various groups in NASA to compare and evaluate approaches to mission and system concepts that could be used for future human exploration missions. In general, they are intended to identify and clarify system “drivers,” or significant sources of cost, performance, risk, and schedule variation. However, they do not represent a final or recommended approach to any of these missions. Comparing alternative approaches in this manner provides the basis for continual improvement to the general understanding of future human exploration missions and to technology investment plans in particular. In the context of this report, they represent the most appropriate source for identifying future EVA roles and activities consistent with NASA’s Strategic Plan as discussed previously.

Three recently NASA-developed DRMs are described here: a free-space assembly and servicing facility, an approach for lunar surface exploration (actually an evolutionary approach with several phases and thus several scenarios), and an approach for Mars surface exploration. These three mission concepts have had a significant amount of effort devoted to them in the recent past and thus represent what are probably the most thoroughly evaluated human exploration missions currently under consideration by NASA. Two other missions, the exploration of small bodies such as asteroids and comets, and the exploration of the icy moons of Jupiter, have been less thoroughly studied but have been of recurring interest as possible destinations and address that aspect of the NASA Strategic Plan that identifies missions beyond Mars as eventual destinations for humans. These two missions will also be discussed and illustrated.

Free-space Assembly, Maintenance, and Staging. This DRM was constructed to examine some of the ambitious science missions currently under study in the NASA Office of Space Science, specifically the assembly, checkout, and eventual maintenance of very large space-based astronomical facilities. Unlike today’s space-based telescopes, the facilities envisioned to answer fundamental questions of astronomy are likely beyond the size that can be accommodated as pre-assembled payloads within the volume capability of Earth-to-orbit launch vehicles. Ambitious science facilities will also be extremely difficult to deploy, construct, rescue, service, or repair in space without sophisticated capabilities for manipulation and mobility. Such capabilities may be provided through the collaborative partnering of advanced robots, autonomous or remotely operated systems, and/or humans on site. Therefore, it was presumed for this DRM that future large-aperture observatories will require in-space assembly, calibration, and as a result, significant support infrastructure to enable these tasks. This capability will also allow science platforms, once in operation, to be serviced for routine system maintenance or equipment replacement, extending the science-gathering lifetime of the facility. Or specific science instruments may be upgraded or replaced, enhancing overall science capability. This model for on-orbit servicing and upgrades of science platforms has been applied with spectacular results to the Hubble Space Telescope over the course of four Space Shuttle servicing missions.

In addition, if properly located within Earth-Moon space, such a facility could be used for assembly, checkout, and deployment of human exploration missions to lunar, small bodies, or other destinations. And, in a related capacity, the isolation of such a facility could be used for the

return and initial examination of samples returned from Mars or other planetary bodies where biological activity is hypothesized.

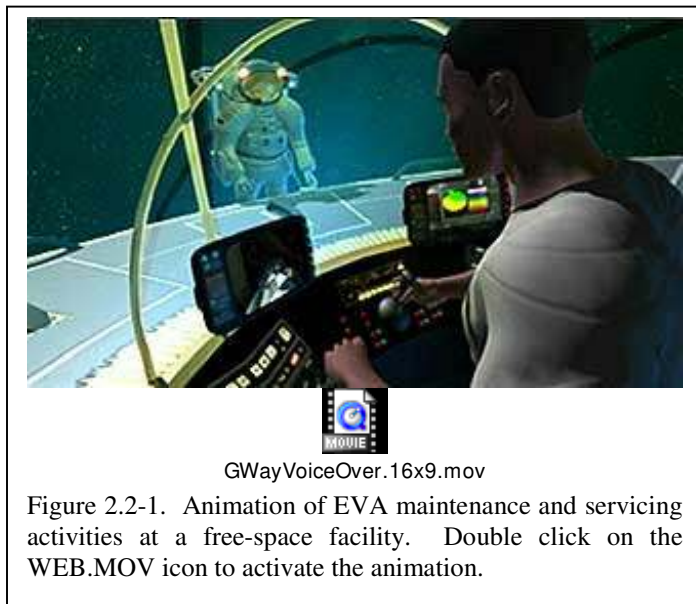

Figure 2.2-1. Animation of EVA maintenance and servicing activities at a free-space facility. Double click on the WEB.MOV icon to activate the animation.

It is the assembly, checkout, and maintenance of large aperture telescopes that has been examined in the most detail and thus will serve as the basis for illustrating the role and activities of EVA in this scenario.

Studies by NASA have focused on one potential facility located in the vicinity of the Moon, specifically at the Earth-Moon L_1 Lagrange point. This Lagrange point gateway is particularly advantageous as an assembly and servicing node as it enables very low-energy transfers to the Earth-Sun Lagrange points—locations considered ideal for advanced astronomical

instruments and solar weather monitors – while remaining within relative proximity of Earth for accessibility by humans and robots.

Several representative advanced science platform concepts are presently under development by various NASA science teams, including the Filled Aperture Infrared (FAIR) Telescope concept. The FAIR telescope is a post Next Generation Space Telescope (NGST), large-aperture far infrared and sub-millimeter telescope designed to meet anticipated high-priority science objectives. This telescope is representative of the type of large-aperture facility that would greatly benefit from assembly and servicing by humans and robotic systems at an L_1 assembly, maintenance, and staging location. The animation in Figure 2.2-1 illustrates one concept for this assembly, maintenance, and staging facility along with the EVA systems that would be based there. In this particular animation, these EVA systems are shown performing typical maintenance and servicing tasks on the facility itself.

FAIR-DART Telescope. Many concepts have been identified for large-aperture reflector telescopes. These concepts range from segmented, solid-surface reflectors that must be deployed or erected on orbit to membrane

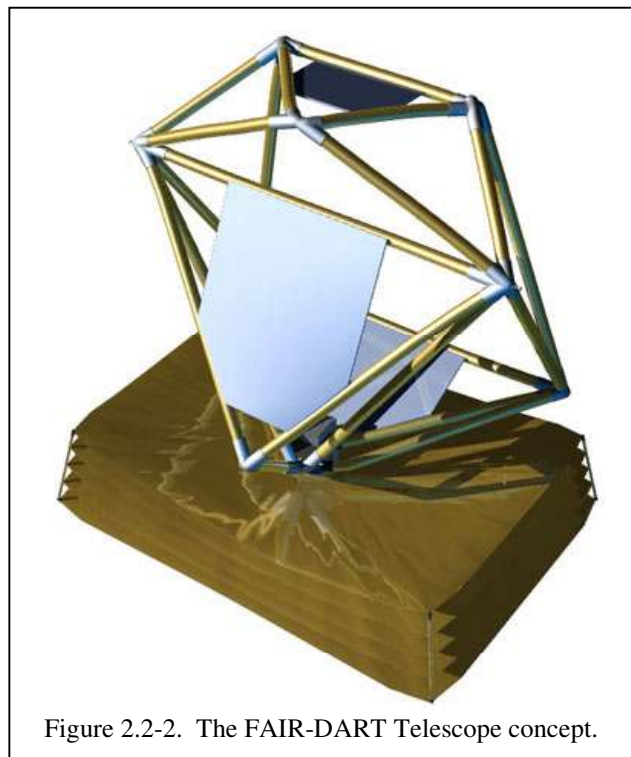

Figure 2.2-2. The FAIR-DART Telescope concept.

monoliths that must be inflated or unfurled on orbit. The first space-based telescope to use a deployable mirror will be the NGST, currently planned for launch in 2010. Although very technically aggressive, even the NGST's 6.5-m-diameter deployable reflector is small enough that it can be segmented into a single circumferential ring of panels and folded for launch using a relatively simple arrangement of hinges and latches. So-called "one-ring" segmented reflectors are desirable due to their mechanical simplicity, but they are limited to deployed diameters no more than a factor of 2.5 to 3 larger than the launch vehicle shroud. For large aperture diameters of 5 to 10 times the launch vehicle shroud diameter, it is necessary to consider either multi-ring segmented reflectors or unfurled membrane reflectors. In the future, it is hoped that advances in active-control and wavefront correction technology will make membrane reflectors practical. Application of membrane reflectors is the basis of the Dual Anamorphic Reflector Telescope (DART), illustrated in Figure 2.2-2, a proposed concept for the FAIR Telescope mission.

The size, intricacy, and assembly precision of a facility like this FAIR-DART concept, coupled with the lightweight and potential fragility of the facilities structure, ruled out the traditional deployment approach exemplified by the NGST. These same factors proved a significant challenge for a purely robotic assembly and checkout. Experience with the Hubble Space Telescope also indicates that this facility could be visited several times during its operational

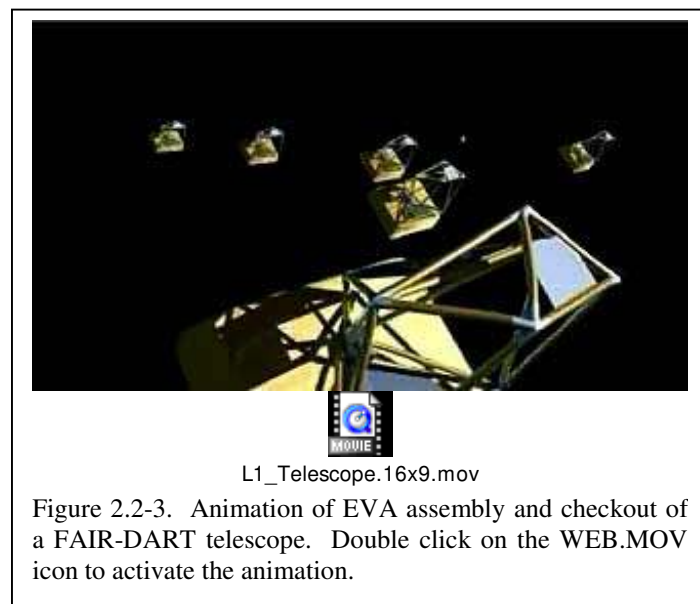

Figure 2.2-3. Animation of EVA assembly and checkout of a FAIR-DART telescope. Double click on the WEB.MOV icon to activate the animation.

lifetime for instrument upgrade or system repair/maintenance. Because of this variety of task complexity, task frequency, and risk associated with the FAIR-DART Telescope assembly and maintenance, a study effort was undertaken to identify a number of human and robot agents of differing capabilities to aid in assembly and servicing operations. It is assumed that certain agents can be combined to form a team, or squad, optimal for these tasks. The animation in Figure 2.2-3 illustrates one possible combination of humans and robots performing the initial assembly and checkout of one of these FAIR-DART telescopes. Though the FAIR-

DART telescope has been assumed for study purposes, the capabilities of most agents are generic enough to be applied to any science platform. It should also be noted that concepts for large astronomical facilities have also been proposed that would be assembled and operated on the lunar surface.

Lunar Surface Exploration and Utilization. This DRM was recently constructed from a variety of sources extending back to the Space Exploration Initiative (i.e., the late 1980s) through the present (Duke, et al., 2003). As such, it covers a wide range of topics from the scientific background and rationale for surface investigations, hardware, and operations for representative surface activities, and several relatively detailed mission descriptions used to illustrate how suggested mission categories might be carried out at specific locations. The remainder of this

Lunar Surface Exploration and Utilization section has been adapted from that report, augmented with illustrations and animations, to describe EVA roles and activities.

The exploration of the Moon has principally been carried out in the Apollo Program, the Russian Luna Program and, more recently, by the Clementine and Lunar Prospector missions. In the late 1980s, the Lunar Exploration Science Working Group (LExSWG) examined the scientific strategy for lunar exploration, focusing principally on the need for additional orbital data (LExSWG, 1995). Much of the strategy proposed by the LExSWG has either been accomplished by Clementine and Lunar Prospector, or will be accomplished by the SMART-1, SELENE, and Lunar A missions. Recently, the lunar science community has undertaken a project (New Views of the Moon) to consider the implications of merging the diverse data sets obtained from lunar samples and the orbital data that has recently been collected (Lunar and Planetary Institute, 1998). This will lead to the publication of a compendium targeted for 2003. Taylor and Spudis (1990) documented questions of lunar origin and history that could be addressed through a lunar base program.

The National Research Council recently concluded a study for NASA (NRC, 2002) that has provided priorities for scientific exploration of the solar system through the next decade (2003-2013). Their proposed strategy includes a South Pole–Aitken Basin sample return mission to the lunar far side, which could address a number of scientific issues and is targeted to a place where human missions are not likely for a considerable time in the future. The scientific community is also interested in the possibility of conducting polar exploration to understand the nature of volatile concentrations that appear to exist at the lunar poles, based on Lunar Prospector data (Feldman et al., 2001).

The principal functions of the astronauts on the lunar surface are to conduct field investigations, describe geological relationships, collect samples, conduct preliminary analyses of some of these samples and prepare others for return to Earth, emplace geophysical instruments, monitor and calibrate instruments as needed, and report their observations and discoveries to Earth. To carry out these activities, they must be able to:

- 1) have sufficient mobility on the lunar surface to enable a good selection of terrains and materials for emplacement of instruments and collection of samples.
- 2) carry out EVAs away from the specific landing zone.
- 3) have accurate navigational capabilities (such as the GPS system on Earth) for correlation of location to images and surface features, and for tracking and traverse planning.
- 4) teleoperate mobile robotic exploration and sampling systems.
- 5) use special-purpose tools for sample collection, including core tubes and drills.
- 6) conduct analyses in a field laboratory.
- 7) store and archive samples.
- 8) communicate their findings to Earth.

They must be sustained and supported on the lunar surface by various types of systems, participate in the planning of day-to-day activities, and communicate regularly with Mission Control and scientists on Earth.

EVA during the Apollo program was very successful, but also very tiring for Apollo astronauts. The effort involved in conducting EVAs with space suits having limited mobility (in particular the EVA gloves) detracts significantly from the long-term performance of crewmembers on the lunar surface. The ability to reuse space suits many times is central to future long-term lunar surface activities, as is the ability to clean suits (this is a lesson learned from the Apollo Program where lunar dust degraded EVA suits, to the point of being unusable, in a very short period of time). The certification of suits for reuse must be addressed. A variety of tools and capabilities that can improve EVA performance must be demonstrated, including advanced information systems allowing easy communications between the crewmember on EVA, the crew inside a habitat, and Earth. Combinations of EVA with mobile transportation systems should be demonstrated. The ergonomics of EVA should be evaluated in sufficiently controlled and numerous experiments to be statistically significant. The problem of requiring pre-breathing of oxygen prior to EVA either has to be addressed through habitat design or through a new generation of high-pressure suits. For later missions and for Mars missions, more than one EVA team may be in the field at the same time. Operational and safety procedures for this event must be developed.

To illustrate these functions and activities, in particular as they relate to EVA, three examples from the Lunar Surface Reference Mission will be presented here, with supporting illustrations and animations: astronomical instruments, technology test bed, and long-range, long-duration sorties.

Astronomical Instruments. The Moon has been advocated as a base for astronomy that could be competitive with placement of telescopes in the Earth-Sun L₂ point as described in the previous DRM (Mumma and Smith, 1990). The Moon's surface provides a very stable base for large telescopes or interferometers, with no atmosphere and only occasional meteoroid impacts or very small moonquakes to jiggle its surface. A telescope emplaced on the Moon should be more easily pointed and should have less time lost to movement-induced vibrations than one in free space, due to the ability to transfer energy to the surface. The shadowed craters near the lunar poles may provide a low-temperature environment that may be suitable for very low-temperature infrared telescopes (van Susante, 2002). And the lunar far side is available for radio astronomy with no chance of interference from artificial radio waves from Earth. Telescopes generally will be operated from Earth without on-site attention. However, the most important characteristics of a lunar telescope facility may be the relative ease of maintenance and evolution of the facility by astronauts. Astronauts could work from a facility that could be shielded against both solar particle events and cosmic rays using lunar regolith as the shielding material. A single set of facilities can be provided that would allow astronauts to perform routine maintenance and upgrading of the observatory in occasional visits, including adding telescopes or upgrading instruments. The same facilities can be used to support other

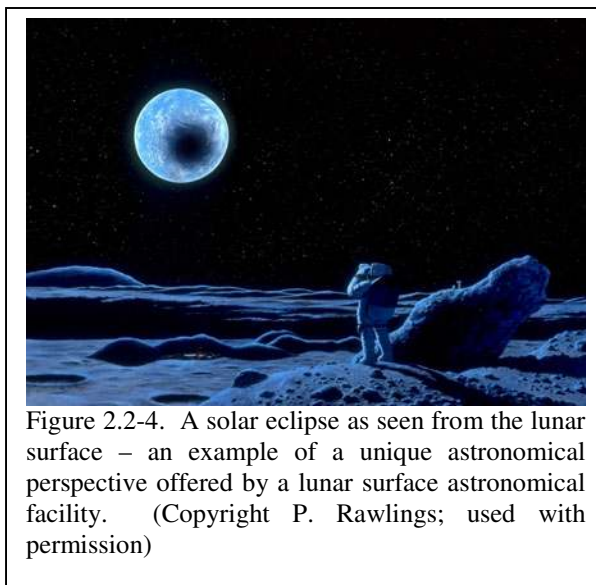

Figure 2.2-4. A solar eclipse as seen from the lunar surface – an example of a unique astronomical perspective offered by a lunar surface astronomical facility. (Copyright P. Rawlings; used with permission)

lunar exploration objectives. Design of the telescope, infrastructure and operations can mitigate threats from lunar and meteoritic dust.

The functions that must be performed by astronauts on the lunar surface to support the construction and maintenance of astronomical instruments consist principally of installing observational systems, adjusting and calibrating them, and ensuring that their power and communications links operate properly. They may monitor the installed system from a habitat during the “commissioning” or initial start-up phase, in which multiple EVA visits to the installation site may be required. To carry out these activities, they must be able to: (1) Access stowed equipment and remove it from lunar lander(s); (2) transport the equipment to sites, in some cases many kilometers from the landing zone; (3) assemble or deploy facility systems; and (4) maintain 2-way communication with Earth during these procedures. For most astronomical instruments, once installed, human activity in their vicinity is to be avoided, to minimize the possibility for contamination of the optics.

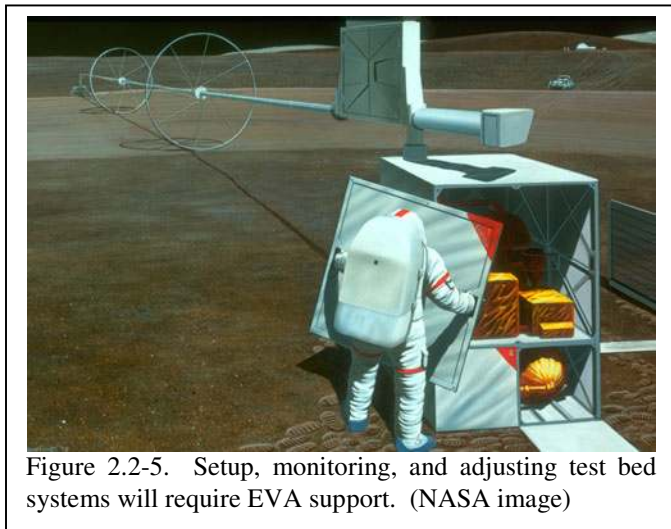

Figure 2.2-5. Setup, monitoring, and adjusting test bed systems will require EVA support. (NASA image)

Technology Test Bed. Although near-term human exploration and development missions to the Moon are expected to be relatively brief in duration, perhaps with a total of 30 days of surface activity, they will lay the basis for longer periods of activity leading to long-term and possibly permanent human activities. Some of the capability important for future missions will be contained in the design of the elements installed to support the lunar outpost (e.g. life support systems, rovers, etc.), while experiments may be required to understand the feasibility of a future objective (e.g. pilot studies of resource

extraction). The characteristics of the technology and operations demonstrations that would be beneficial can only be suggested here. The specific experiments to be conducted should be designed to demonstrate current capabilities and suggest directions for subsequent development. Where it is possible, several capabilities might be demonstrated with a single experiment. Each experiment can be designed to provide benefits to the current mission as well as feed-forward to future capabilities. Because of the demands of EVA, experiments should be designed for deployment by astronauts with remote control and monitoring operations from control rooms on the Moon or on Earth.

Initial long-duration stays on the Moon for periods of about 30 days may mimic the surface stay time for early Mars missions, in which astronauts might spend 30 days on Mars, living out of their lander. The entire range of operational procedures (logistics, EVA traverses, maintenance, consumables management, etc.) that must be carried out in the Mars surface missions could be practiced on the Moon. A good understanding of these operations and the design of technical support for the crew could have a major impact on the amount of useful time spent by astronauts doing scientific work in short-duration stays on Mars.

Long-Range, Long-Duration Sorties. The maximum duration of a lunar mission conducted by Apollo was three days. Longer crew stay times allow for broader surface exploration, more intensive special sampling, and a range of technological and operational experiments and demonstrations to be performed. The opportunity may also exist to revisit a site if the initial sortie finds something that would benefit from a follow-up visit, or if the initial goals could not be accomplished in the first EVA.

Apollo astronauts were well served by the Lunar Rover, which attained speeds of up to 5 km/hr and allowed the crews to explore to a range of several kilometers from their lunar lander. The area available for exploration increases as the square of the distance from a central facility, so surface mobility is a good way to increase the productivity of exploration missions. Because the energy required for systems that move on the surface is low, compared to rocket devices for point-to-point or hovering trajectories, extending exploration range with surface vehicles is effective, though more time is required as surface speeds are likely to remain low, in the absence of prepared roadways. For early lunar exploration, a variety of surface mobility systems is likely—robotic systems with teleoperation capability from Earth or a lunar operations center; piloted rovers for short duration—relatively short distance traverses, and pressurized vehicles for long-distance traverses that may extend over several Earth days and hundreds of kilometers (See animation in Figure 2.2-6).

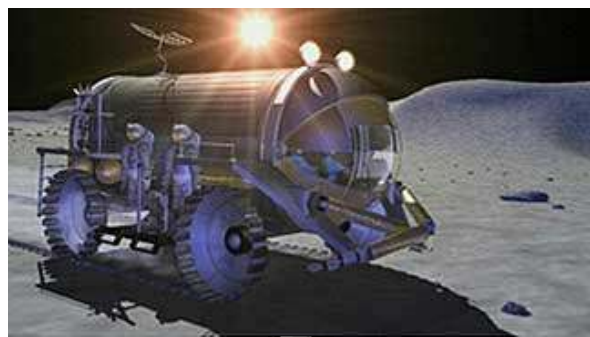

LnrP_Rover.16x9.mov

Figure 2.2-6. Animation of a range of surface exploration activities expected for lunar operations. Double click on the WEB.MOV icon to activate the animation.

The issues for long-duration lunar missions or permanent facilities include:

- the robustness of vehicles and space suits that have to operate in the lunar environment for extended periods (the Apollo Lunar Rovers had mechanical problems and would not have survived much more use)
- designs that are amenable to maintenance and repair
- multipurpose systems with replaceable tools that can be used in teleoperated or piloted mode
- long-lived bearings
- dust protection
- pressurized systems
- lightweight airlock designs
- support systems for astronauts on EVA

Power systems for surface rover mobility systems need to be developed. As surface exploration strategy depends on the reliability of surface transportation (Apollo astronauts were limited in range to the distance that they could walk back to their lander), many issues must be faced with respect to crew safety, ranging from reliability of systems to strategies using multiple surface vehicles.

Mars Surface Exploration and Utilization. This DRM was recently constructed from a variety of sources extending back to the Space Exploration Initiative (i.e., the late 1980s) through the present (Hoffman, 2001). This DRM also covers a wide range of topics focusing mainly on hardware and operations for representative surface activities, and several relatively detailed mission descriptions used to illustrate how suggested mission categories might be carried out. The remainder of this Mars Surface Exploration and Utilization section has been adapted from this DRM, augmented with illustrations and animations, to describe EVA roles and activities.

To illustrate these functions and activities, in particular as they relate to EVA, three examples from the Mars Surface Reference Mission will be presented here, with supporting illustrations and animations: field work; a field camp; and finally inspection, maintenance; and repair activities.

Exploration Field Work. A key objective of the Mars surface mission is to get members of the crew into the field where they can interact as directly as possible with the planet they have come to explore. This section will discuss one of the means by which this will be accomplished—the use of EVA operations to carry out field work in the vicinity of the outpost.

Although the list of these field exploration activities will undoubtedly grow as specific objectives are chosen and the means to accomplish them are defined, two examples can serve to illustrate the range of these activities: field geology/mapping and intensive field work at a specific site.

The activities of a field geologist on the surface of Mars will differ greatly from EVA activities of the Space Shuttle and International Space Station eras. These differences will impact both the design and use of EVA systems for surface activities. Some of these activities and resulting impacts include the following (Eppler, 1997):

“Geologic field work involves collecting data about the spatial distribution of rock units and structures in order to develop an understanding of the geologic history and distribution of rock units in a particular region.”

“It is an oft-stated but correct maxim that the best field mappers are the ones who have seen the most rocks. Geologic field work on the planets, if it is to be worth the significant cost needed to get the geologists there, will require both EVA suits that will allow EVA crew to walk comfortably for hours at a time, and rovers that will allow the crew to see as much terrain as possible. Further, the visibility provided must be as free of optical distortion [as possible] and preferably without degradation of color vision. In particular, seeing colors allows discrimination between otherwise similar rock units.”

“One distinction that needs to be emphasized is the difference between field mapping and pure sampling. A popular misconception is that geologists conduct field work

purely for the purposes of sampling rock units. Sampling *is* an important part of field mapping, but sampling in the absence of the spatial information that field mapping provides leads to, at best, a limited understanding of the geology of a particular area. Having said that, the nature of the rock exposure in a given area can limit the amount of field mapping that can be done, and *can* drive field work efforts to conducting a sampling program that, with some ingenuity, can provide the basics for understanding the broad geologic context of a particular locality.”

With this background, a typical field exploration campaign will begin with one or more questions regarding the geology in a particular region and the identification of specific surface features—based on maps and overhead photos—that offer the potential for answering these questions. Traverses are planned to visit these sites, typically grouping these sites together (into multiple traverses, if necessary) to meet the limitation of the equipment or environment (e.g., EVA suit duration limits, rover unrefueled range, crew constraints, local sunset, etc.). Depending on the anticipated difficulty of the planned traverse, the crew may choose to send a teleoperated robot to scout the route, sending back imagery or other data for the crew to consider. In addition, crew safety concerns when entering a region highly dissimilar from any explored before or an area with a high potential for biological activity may dictate the use of a rover in advance of the crew. The EVA crew walks, or rides if rovers are planned for the traverse, toward the first of these planned sites using visible landmarks and cues available through the surface navigation system. The crew stops at this site to make observations, records data (e.g., verbal notes to be transcribed later, imagery, sensor readings from those instruments brought on the traverse, etc.), and gathers samples as appropriate. If a return visit to this site, either by an EVA team or a robotic device, is deemed necessary to gather additional data or samples, then the position is marked for future use within the navigation system used for surface traverses. The crew then proceeds to the next site in the plan until all sites have been visited or until required to return to the outpost. At any point in the traverse it may be desirable to stop at unplanned locations due to interesting features that may not have been recognized as such during the planning for the traverse. The crew may carry out similar activities at these unplanned sites. Real-time voice and data, along with some amount of video, are sent back to the outpost to those members of the crew that are monitoring the progress of the traverse (along with other duties). On returning to the outpost, the EVA crew will ensure that all curation procedures are carried out and that information gathered in the field is transcribed or otherwise stored in the outpost data system.

Intensive field work at a single site may involve one of several activities associated with science payloads. One specific example is a “shallow” (i.e., approximately 10 m maximum depth) drill. There are several key scientific and operational questions requiring subsurface samples acquired by this type of tool. Examples include searching for subsurface water or ice, obtaining a stratigraphic record of sediments or layered rocks, or obtaining samples to be used for a search for evidence of past or extant (possibly endolithic) life. A traverse of the type discussed above will probably have been carried out to examine candidate sites for the drill, with the acceptable sites being placed in a priority order. Drill equipment will be moved to the site, most likely on a trailer pulled by either the unpressurized or robotic rovers, and set up for operations. The crew will retrieve core samples and put them through an appropriate curation process before eventual analysis. After concluding drilling at a particular site, the drill equipment will be disassembled and moved to the next site, where this procedure will be repeated.

The two key characteristics that should be noted here are that drilling activities, and by inference other intensive field work, will involve repeated trips to a single location (or the use of a remote field camp; see the section devoted to this topic) and an extensive interaction with tools and equipment at these sites.

Many of these EVA activities are illustrated in the animated graphic of Figure 2.2-7.

The Field Camp. A primary objective of sending human crews to Mars is to allow them to explore, in person, a region containing diverse, interesting surface features. However, operational and safety requirements will impose constraints on those locations where the crew and their cargo vehicles will be allowed to land before they can begin these explorations. Planetary protection protocols may also limit landings to those regions from which samples have been returned to Earth by a robotic spacecraft—samples that have proven sterile and biologically safe. Additionally, landing sites may be restricted to those areas that are relatively benign in terms of hazards and trafficability. These requirements of diversity and safety may well work against each other, perhaps placing the interesting sites only within reasonable proximity to the safe/benign landing sites. It is to be expected, given the diversity of Martian geology, that one or more of the key sites identified for exploration by the crew will be located some significant distance away from the landing site.

It is also reasonable to assume that some of these remote sites will be selected for extended, detailed study by the crews. Activities such as deep drilling, trenching and other forms of surface excavation, or simply detailed study of certain features (e.g., sedimentary layering found in ancient lake beds or that are exposed at a cliff face) will require periods of time greater than are reasonable for a single EVA.

The capability to remain at one or more of these remote sites for extended periods—through the creation of a field camp—will greatly enhance the productivity of human exploration. Such a capability will reduce the need for the crew to commute from the central



MarsGeoVoice.16x9.mov

Figure 2.2-7. Field work activities as they may be carried out by a number of agents on the surface of Mars. Double click on the WEB.MOV icon to activate the animation.



Figure 2.2-8. Crew operating from a field camp will allow interesting sites to be explored in more detail than would be possible if the EVA were staged from the landing site. (NASA image)

base to the site and back again, thereby providing the means for exploring a site for periods longer than are possible in a single EVA.

In addition to the previously mentioned drilling and digging activities, this capability will allow walking or unpressurized rover traverses to extend beyond what is possible from the central base prior to the arrival of multiple pressurized rovers. In this case, the field camp could be located at the maximum range allowed by operational considerations (e.g., the unsupported walkback distance allowed by EVA suit consumables or crew fatigue limits) and would then serve as the staging base from which additional traverses would be carried out. Communication systems at the field camp will serve as a data relay between parties in the field and the remainder of the crew at the central base.

Typically, site(s) for a field camp will be chosen to meet certain mission objectives; there may be several field camps established during the course of the surface mission. Each site will be selected based on remote sensing data gathered from orbit or by teleoperated robots (either airborne or moving across the surface) or may have been identified by the crew during the course of a previous surface traverse. Supported by their terrestrial colleagues, the crew will plan the content and timeline of likely activities to be spent at this site, allowing necessary equipment and supplies to be identified. Unpressurized rovers (and, when available, the pressurized rovers) will be used to transport equipment and supplies to the site. More than one trip by rover to the site may be required. Other field camp infrastructure, such as a pressurized habitation structure, power system, and life support consumables, must also be transported to the field camp site.

The first possible implementation is to use one of the pressurized rovers as the habitat and power system for the field camp. This rover will have already been designed to support several crew for many days away from the central base and thus will meet these needs for the field camp. The pressurized rover can tow at least a portion of the other equipment to the site and then be parked in a convenient location near the other activities taking place. The unpressurized rovers can provide crew mobility while the pressurized rover is in this fixed location.

The second implementation is to use a smaller version of an inflatable habitat. Such a system could be towed into position and set up by the crew. The technology used for the inflatable pressure vessel as well as other rigid structures (such as the airlock door) would be the same as that used at the central base. Other systems, such as power and life support, could be variations on the technology used for the pressurized rover or that used at the central base.

The primary purpose for a field camp capability is to place the crew in close proximity to features or items of scientific interest. Thus the capability for daily EVA activities is assumed for these field camps. EVA activities may be as uncomplicated as walking traverses in the vicinity of the field camp to the setup, operation, and maintenance of substantial equipment, such as drills or trenching tools.

Because of the emphasis on external activities while at the field camp, activities internal to the habitat will tend to be focused on supporting these activities. Basic capabilities for meal preparation, personal hygiene, and sleeping accommodations will be provided. Other activities likely to be carried out by the field camp crew will focus on preparation for the next EVA. This includes any required maintenance or minor repair of the EVA suits, logging data from the experiments, and preparing samples (such as core sample from the drill) for transportation back

to the central base. Major repair of equipment, if needed, is assumed to be accomplished at the central base.

Many of these EVA activities conducted from pressurized rover or remote field camps are illustrated in the animated graphic of Figure 2.2-9.

Inspection, Maintenance, and Repair. The capability to perform inspections, maintenance, and repair on all systems will be required during all phases of the surface mission.

Large amounts of hardware from many systems will be exposed to the Mars environment—surface and wind-borne micro-dust, wide-ranging temperature extremes, and a much thinner atmosphere than Earth—all life span shortening, problem enhancing factors for hardware. Inspection, maintenance, and repair of these systems will be carried out by both robotic systems and by the human crew during some phase of the mission. The crew, while much more capable of detailed maintenance than robotic systems, will still be constrained by dexterity-reducing EVA suits when doing exterior work. Mass and volume restrictions will limit the types and amounts of maintenance equipment and spare parts the crew has available. The time devoted to maintenance will be borrowed from other activities that the crew (and others) may want to perform instead, and use skills in which

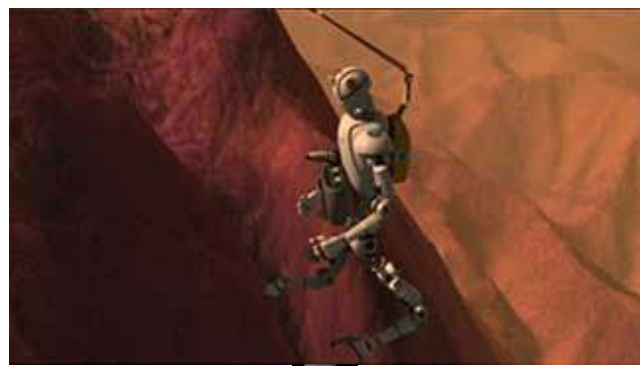

MarsFuture.16x9.mov

Figure 2.2-9. Field work activities as they may be carried out from pressurized rovers or from field camps. Double click on the WEB.MOV icon to activate the animation.

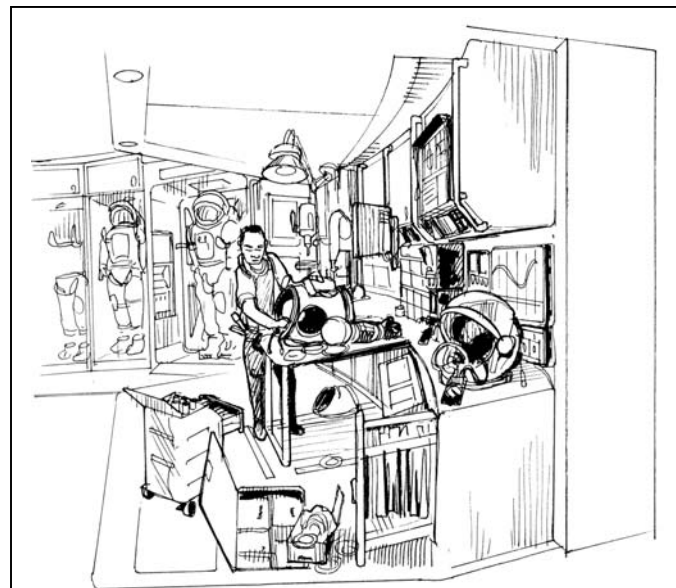

Figure 2.2-10. An artist's concept for a maintenance and repair facility within the pressurized habitat. This facility will be capable of maintaining the EVA suits that will be a key element in supporting the crew's exploration activities.

the crew must be trained instead of deeper training in other skills. Distance from the Earth (and potential sources of information about problems and repairs) will hamper maintenance efforts. All of these factors must be taken into account as early as the equipment design phase to ensure that the best use is made of the crew and equipment on the surface.

As discussed in previous sections, the EVA suit will be used for a large percentage of the exploration work carried out on this mission. This makes availability of the suit a high-priority item, which in turn places a high priority on reliability and ease of maintenance. Thus suits (defined to be both the pressure garment and PLSS) are assumed to use the built-in diagnostic monitoring capability and built-in test equipment. While a suit is in use, the

diagnostic monitoring system will be recording performance data that can be downloaded later for use in trend analysis and will be logging maintenance actions that will be required once the suit is returned to the habitat. When the suit has been cleaned and brought into the habitat, the suit data system will be connected to the integrated health status information system for transfer of the performance data and the maintenance action log. The crew will be able to review the maintenance action log to determine the priority of those actions compared with other maintenance tasks on their schedule. The crew can also access, from the integrated diagnostic status information system, the specific maintenance procedures as well as a list of required repair tools and parts for the required maintenance actions. They will also be able to generate a list of the location of the required spare parts. The suit should be capable of being disassembled so that all moving parts susceptible to dust intrusion can be cleaned and, if necessary, lubricated. Component commonality among the suits and among other systems used at the outpost will allow discrepant parts to be replaced immediately, restoring the suit's availability and allowing the discrepant part to be repaired (if possible) at a pace that does not impede further EVA activities. Built-in test equipment is used to verify that maintenance actions have returned the necessary functionality to the suit component(s) receiving maintenance and that the reassembled suit is ready for use.

The suit diagnostic monitoring system is also assumed to be capable of discriminating between maintenance items that can be logged for later action and those that require immediate attention in the field. The diagnostic monitoring system will provide appropriate notification to the crew (this includes the crewmember in the suit and the other crewmember(s) participating in the EVA) of the nature of the emergency and advice on action(s) to take. Examples of repairs that will require immediate action include a suit puncture resulting in an ongoing loss of pressure or a failure of one of the several systems contained in the PLSS. The EVA crew will have the capability to make temporary repairs (e.g., patch the suit puncture) or to isolate the failed component and switch to another system that provides the same functionality (e.g., tap into another EVA suit power supply or into an EVA consumables supply on board a rover). These emergency actions will be designed such that sufficient time is available for the EVA crew to return to the habitat where permanent repairs can be made.

Other Destinations: Small Bodies and Icy Moons. In addition to the destinations and capabilities described in the preceding sections, those that have received the most mission and system planning attention since the outset of the space exploration era, there are several other destinations that help to round out the range of destinations and capabilities that are likely during the next 20 to 30 years. These include asteroids, comets, and the icy moons of Jupiter.

Asteroids and comets represent the most numerically abundant class of objects in

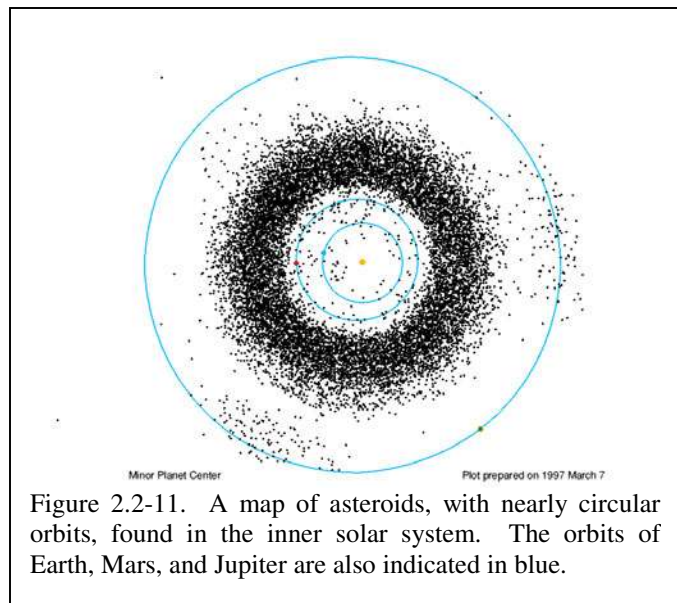
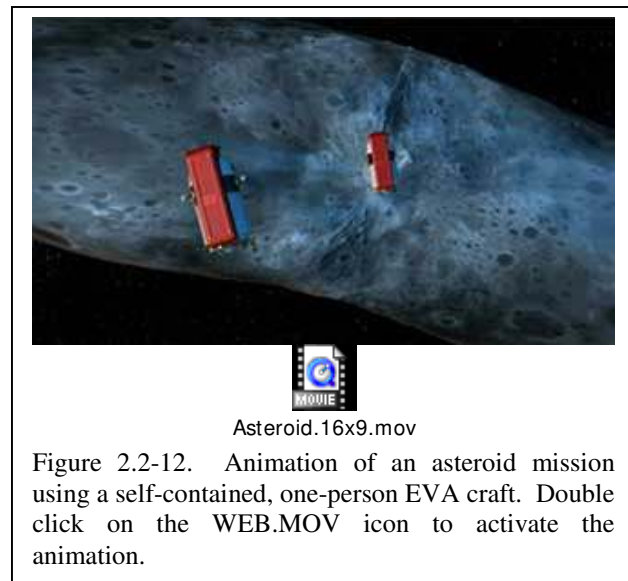

Figure 2.2-11. A map of asteroids, with nearly circular orbits, found in the inner solar system. The orbits of Earth, Mars, and Jupiter are also indicated in blue.

the Solar System. Figure 2.2-11 illustrates known asteroids of the inner Solar System (i.e., out to the orbit of Jupiter); there are many other comets and asteroids with much more elliptical orbits that would add to the volume illustrated in this image. A particular group of asteroids have generated a higher level of interest due to the fact that their orbits cross that of Earth and thus represent a potential collision hazard. Other asteroids in this group have generated interest due to their potential as a significant source of useful minerals. Similarly, comets have drawn attention as a potential source of water and other volatiles that are of potential use for human missions, for life support, and as propellants.

These objects present an operating environment that is a cross between the microgravity, free-space environment of the telescope assembly mission and those of planetary surface exploration.



Like the free-space missions, asteroids and comets have essentially no gravity to hold an EVA crewmember in place, making a walking-type EVA suit useless, and require a means of anchoring so that useful work can be accomplished. However these bodies also possess the dust and potentially abrasive materials of lunar and Martian environment, making both cleaning exterior surfaces and minimizing rotating joints highly desirable features. One approach to this type of exploration is illustrated in the animated graphic in Figure 2.2-12. This concept places the EVA crewmember in a small, self-contained craft that has no appendages for the crewmember's arms or legs, but uses

manipulators of the type described for the Shuttle, ISS, and Japanese Experiment Module (JEM) (see Appendices C and D), to allow the crewmember to interact with the asteroid.

The icy moons of Jupiter present yet another environment in which human crews may operate—the possibility of life existing beneath their frozen surfaces being a principal reason for exploration. These moons are large enough to possess a gravity field that would keep an EVA crewmember from drifting away as described for the asteroids and comets, making a walking EVA suit a feasible option. However, the trapped radiation environment surrounding Jupiter poses a significant hazard to any human crew without significant radiation protection—undoubtedly more than could be accommodated by a walking EVA suit. This is a situation where advanced teleoperated systems could play an enabling role should

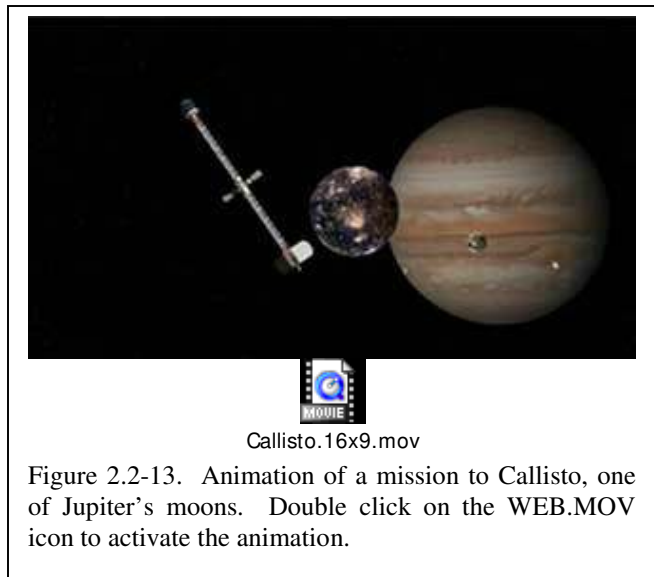

humans enter the Jovian system for exploration or other purposes. The animated graphic in Figure 2.2-13 illustrates one possible means for using an anthropomorphic teleoperated robot in conjunction with virtual presence capabilities to place the crewmember in close proximity to the objective of their exploration. Although probably required in the Jovian radiation environment, such a capability becomes a very useful adjunct to the other EVA capabilities and environments described in the preceding mission scenario sections. An anthropomorphic robot allows the possibility of using tools already developed for human crews and with which these crews should already be familiar.

2.3 EVA Functional Requirements

Based on this view of the future of EVA as depicted in these five DRMs, EVA systems will require several functional capabilities to achieve this vision. Summarizing across the five DRMs, the following general EVA capabilities can be synthesized:

- *Operate in a range of different gravity fields.* Rationale: The five DRMs cover EVA activities that take place in the microgravity of free space as well as the surfaces of asteroids, the Moon, and Mars. While a minimum number of unique systems are preferred, different gravity fields may require different implementations to satisfy the same functional task.
- *Operate in a dust environment.* Rationale: The surfaces of asteroids (as observed from the NEAR landing on Eros), the Moon (as observed on Apollo missions), and Mars (as observed by several landers and orbiting spacecraft) all possess dust on a global scale. Thus far, only lunar dust has been characterized for its mechanical properties and thus its potential impact on EVA equipment.
- *Operate in high-radiation environment.* Rationale: EVA operations in low Earth orbit, where the majority of EVA time to date has taken place, is shielded by the van Allen belts from the higher radiation typical of the areas and destinations described in the DRMs. The magnitude of the difference varies with time and location. Missions in the vicinity of Jupiter will experience particularly high levels of radiation due to the trapped radiation belts at this planet.
- *Operate in extremely low atmospheric pressure or vacuum.* Rationale: Of all the destinations described in the DRMs, only the Martian surface has an appreciable atmosphere, which has a surface pressure of approximately 10 millibars. All other destinations are at a vacuum state.
- *Operate with mobile automated devices.* Rationale: The use of mobile automated devices (a.k.a. robots) can allow the human EVA crews to accomplish more on each sortie by taking on tasks that are suited to their capabilities or that may otherwise be considered too risky for humans.
- *Conduct frequent sorties over extended mission durations.* Rationale: All of the scenarios described previously assume that EVA activities will be a primary activity of the mission and thus will occur as frequently as possible. Daily EVA would be ideal but it is recognized that fatigue induced by the EVA systems, maintenance, and

other crew scheduling factors will limit the EVA frequency to something less than this.

- *Each sortie duration will be consistent with a nominal workday for the crew.* Rationale: With the exception of Mars surface activities, all of the scenarios discussed above will be in environments where the crew can choose the duration of a nominal workday. It is likely that this duration will be chosen to be consistent with that of the support ground crew. Mars has a diurnal cycle somewhat longer than that of Earth and this is likely to define the length of a nominal workday. However, because of the similarity between the length of a Mars day-night cycle (one sol) and that of an Earth day, the required duration as measured in hours is likely to be the same.
- *Human crews could conduct a sortie either directly (i.e., in the environment) or by means of teleoperating a robotic device.* Rationale: As illustrated in several of the future mission scenarios, there are likely to be situations where an EVA task is beyond the strength capabilities of a human, requires higher precision, is in a location considered too risky for humans to enter, or is beyond the operating range of humans in EVA systems. These tasks will then be assigned to a robotic device that is teleoperated by a human. Either situation is considered an EVA sortie.
- *Operate over extended distances away from the landing site or base area.* Rationale: A common feature of the scenarios described previously is the need to conduct EVA activities at some distance away from a landing site or a central operating base. In some cases, these activities could potentially take place tens to hundreds of kilometers away from this central operating base. This typically results from the requirement for a safe place to land or a benign location for a central base, whereas interesting or significant locations for exploration and research are in locations not suited to either of these functions. Thus it is necessary to move between these two types of locations, preferably with a minimum of time spent in this transportation process.

2.4 Summary

Ideally, the best solution for this broad future of EVA activities would be for a single integrated EVA system (note: in this case “system” is assumed to extend beyond the traditional view of an individual in a garment with life support; see definitions in the following section) that satisfies all of the capability requirements. It remains to be seen if technological solutions can be found to accomplish this desired outcome. In the following section the history and current state of the art for EVA will be reviewed focusing on these functional capabilities. This will provide an indication of which of these functions have already been demonstrated and to what degree. This will form the starting point for the technology development roadmap. The following section will also describe a functional breakdown structure for all of the systems considered to be part of the EVA “system.” This functional breakdown structure will provide a structure for discussing not only the history and current state of the art for EVA, but a structure for discussing the future needs of EVA.

3.0 EVA SYSTEMS ARCHITECTURE AND FUNCTIONAL CAPABILITIES

The previous section has described several scenarios for future missions likely to occur sometime during the next 25 years that involve the use of EVA. This defines the future end of a technology development roadmap for these systems. To fix the beginning of the roadmap requires an understanding of the current state of the art for EVA systems. This section (and associated appendices) will look at the current state of the art for EVA as the next set in building the RASC roadmap for EVA technology development. This preparatory step also includes looking back at relevant historical systems that indicate what has been accomplished but which may now be dormant. In particular, the Apollo missions represent a branch of EVA (planetary surface EVA) that has been dormant since 1972. Yet there are relevant systems and, perhaps more importantly, lessons learned that should be factored into the development of future EVA, the future vision of which relies so heavily on its use.

The diversity of systems and facilities associated with EVA, for not only operations but development as well, requires a functional organizational structure for these systems. This provides a basis for discussing their evolution and future development. Thus this section describes a structure for the major functional components of the EVA system as it is used in this report. These components are grouped in a WBS-like format that will be used throughout the remainder of this report.

Finally, this section concludes with a refinement of the capabilities and requirements described in Section 2, based on this understanding of the current state of the art for EVA and the lessons learned from previous missions and programs.

3.1 EVA System Functional Breakdown Structure

In order to provide a comprehensive report of design concepts for human-related advanced EVA systems, it is first necessary to define the elements of that system. Figure 3.1-1 is a representation overview of a generalized infrastructure, indicating key basic EVA support equipment and system elements. This section will provide a description in the form of a hierarchy of functionally related elements of this system. This hierarchy will then form the basis for subsequent assessments and discussions contained in this report. Not all branches of this hierarchy will be described to the same level of detail; each will be described to the level necessary to describe these components as they relate to the overall system concepts and sufficient to support the needs of the technology road map, which is the ultimate objective of this study.

Figure 3.1-2 illustrates the first level breakdown of this hierarchy. The **Human Operated External Work System** element contains the bulk of what has traditionally been thought of as EVA systems, including such items as the pressurized garment, the PLSS, ancillary EVA equipment, and supporting robotics. The robotic devices as defined here are those that are under the direct command or supervision of the EVA crew; teleoperated robotic devices are assigned to the next element of this hierarchy. The **Human Operated Internal Work System** element contains all teleoperated robotic devices or telepresence devices operated by the crew from inside a habitat or pressurized rover. It is also the element to which any other EVA support

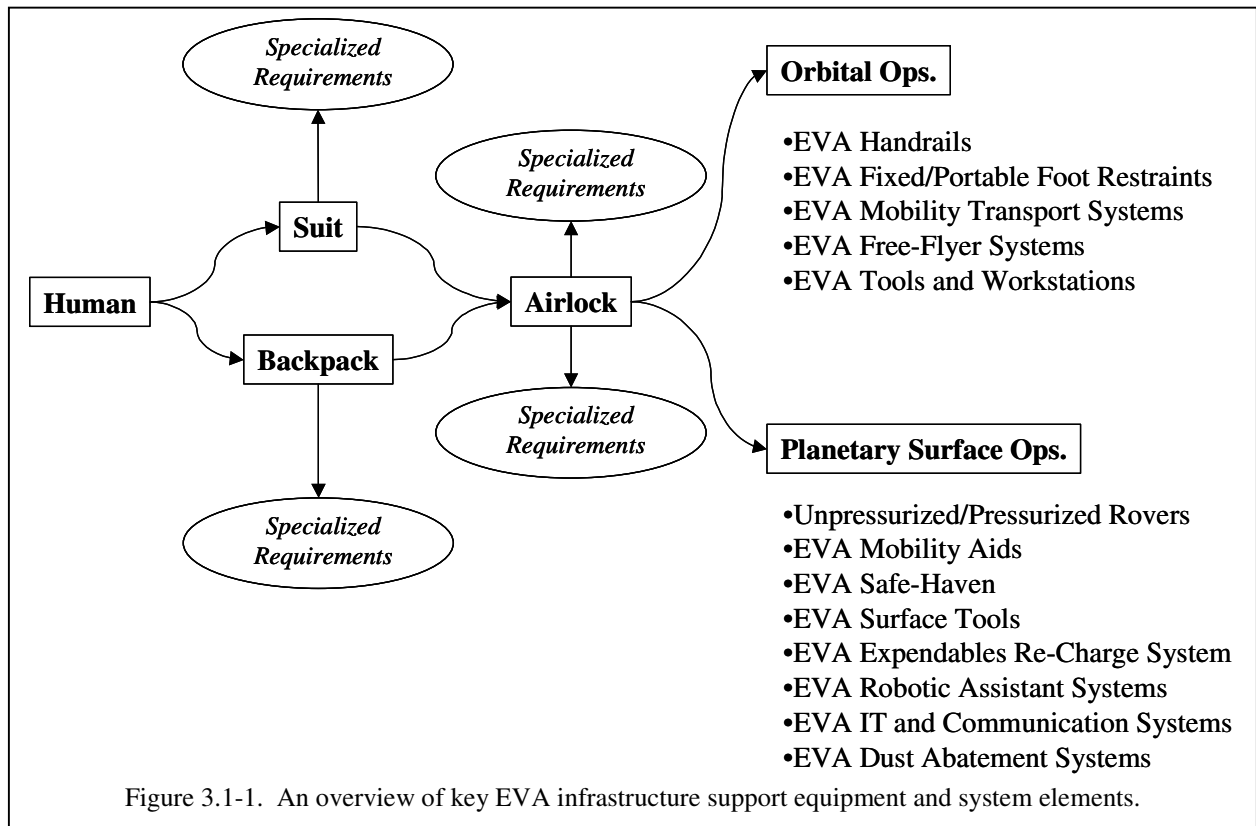

systems internal to a habitat or lander are allocated. The **Transportation System** element contains all human and cargo transportation systems for surface or free-space operations. This includes both pressurized and unpressurized systems sized for individual use or for multiple personnel. The **Support Infrastructure System** element contains those systems that will typically be required to support EVA operations, such as airlocks, communications relays, navigational systems, and remotely cached supplies or safe haven facilities. Finally, the **Ground-Based Support Systems (Earth)** element contains those facilities or systems located on Earth that are needed to develop or test hardware, train crews, or provide operational support for EVAs during a mission. (Autonomous robotic systems are addressed in NEXT, 2002.)

Appendix A contains the next-level breakdown of this hierarchy, providing additional definition of the systems and subsystems that make up these elements.

There is one obvious system characteristic that will become important at subsequent levels that should be discussed at this point, namely the difference between a system suitable for use on a planetary surface and one suitable for free space. There are instances where certain technologies will only work in one regime or another, such as a wheeled rover being suited for planetary surfaces but not free space. There are other examples, such as the EVA pressure garment or the portable life support or some of the robotic assistants, that can perform equally well in either environment (if properly designed). This is also likely to be a benefit from a program perspective, reducing the number of technologies and systems that must be developed and supported. Thus, this distinction will be noted where appropriate throughout the remainder of this report but was not incorporated as a separate level in the hierarchy.

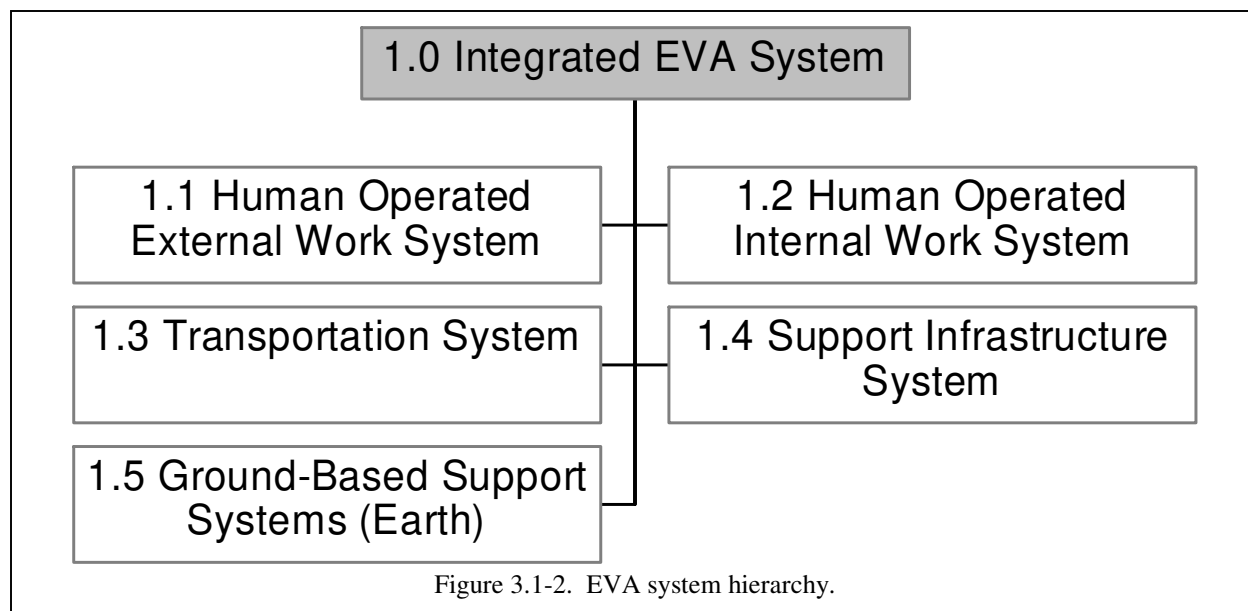

3.2 EVA History and Current State of the Art

Humans have been living and working in space for over 40 years. In that time, we have been performing extravehicular activities for over 35 years, during which EVA crews have worked for approximately 900 hours in the microgravity environment and over 160 hours on the lunar surface. Figure 3.2-1 illustrates key milestones in the advancement of EVA and summarizes the growth in experience as represented by the number of EVA sortie hours accumulated during this time. Rapid advancement in EVA capability in both the U.S. and Russia occurred during the first dozen years of human spaceflight. Since that time, some systems (e.g., planetary surface systems) have been almost dormant while others (e.g., microgravity EVA systems) have evolved and improved incrementally but remain largely based on the technology standards set in the mid- to late-1970s.

An extensive review was made of past and current EVA systems based on the functional breakdown structure just defined. The details of this review can be found in Appendix B (historical systems) and Appendix C (current state of the art). The current state of the art as used here includes not only operational systems but also experimental systems that are testing concepts and technology for future systems. Based on this survey, the current state of the art for each of the functional categories can be summarized as follows:

1.1 Human Operated External Work System. The U.S. STS/ISS extravehicular mobility unit (EMU) and the Russian Orlan M represent the current state of the art for EVA garments and life support. Both of these systems are used in the microgravity environment. However, several experimental EVA garments and life support systems designed for use in a gravity field are in development. A variety of hand tools and power tools have been developed to meet the needs of specific vehicles or activities. These are typically variations of ground-based counterparts, although there are several examples of tools designed to meet the unique need of the space environment.

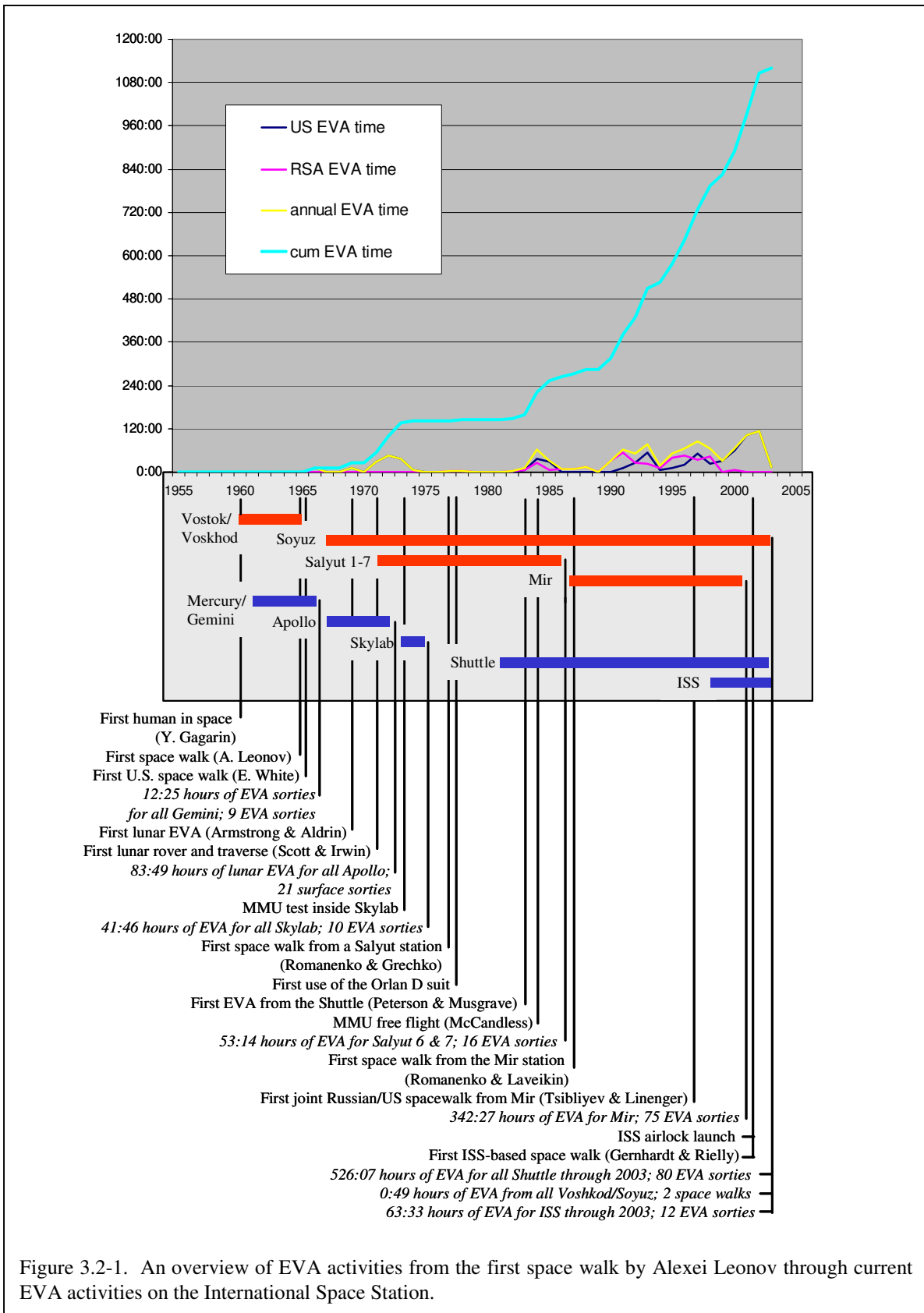

Figure 3.2-1. An overview of EVA activities from the first space walk by Alexei Leonov through current EVA activities on the International Space Station.

1.2 Human Operated Internal Work System. The state of the art for teleoperated robotic devices, the bulk of the systems currently in this category, are represented by the STS Remote Manipulator System (RMS) and the various robotic arms employed on the ISS. Experimental systems, such as Robonaut, represent an expansion in the sophistication and capability of these systems that are likely to be available early in the 25-year horizon of this investigation.

1.3 Transportation System. For the free-space environment, the Simplified Aid for Extravehicular Activity Rescue (SAFER) represents the state for the art for individual maneuvering systems. However SAFER represents an emergency system and thus has limited capabilities. The U.S. manned maneuvering unit (MMU) and its Russian counterpart represent a demonstrated, but currently unused, capability for longer range and endurance transportation in the microgravity environment. On planetary surfaces, the only system demonstrated thus far is the Lunar Rover Vehicle (LRV), last used some 30 years ago. Numerous concepts for both pressurized and unpressurized vehicles have been proposed over time, but most remained only on paper.

1.4 Support Infrastructure System. Many of the elements covered under this part of the functional breakdown arise from the approach to EVA activities described in most of the future scenarios described previously. Airlocks and communications systems are exceptions to this, with the current state of the art represented by the Quest airlock and the local communications system used on the ISS. However, the capabilities of both of these systems must be broadened to handle the environmental conditions on planetary surfaces as well as the increased volume of communications traffic that is likely to occur as the range of EVAs increases, the sophistication of scientific data exchange expands, and the number of robotic devices commanded by the crews grows.

1.5 Ground-Based Support Systems (Earth). The maturation process for any of these EVA technologies and systems will rely on adequate facilities to test these new systems and train personnel in their use. Once deployed, ground-based support will still be required for proper operation of the systems. In the former case, a significant number of human-rated environmental test chambers are still in operation within NASA representing the state of the art for these facilities and, with appropriate maintenance and adequate upgrade of controls and sensors, will provide adequate support in this area. The state of the art in training facilities is represented by aircraft flying parabolic trajectories (zero g simulation) and large water tanks (neutral buoyancy simulation of zero g) that are being operated by several of the ISS international partners. In some cases, these facilities are even being operated by universities for research and teaching purposes. Analog test sites will eventually be needed to support development of these systems as well as training of crews. Selection of these sites will depend on the destination being simulated, but efforts are currently under way to identify, and in some cases use, sites for early testing and development. Both the U.S. and Russia are operating state-of-the-art ground support facilities for EVA missions. However, communication time delays and the magnitude of EVA operations described in the vision of the future indicate that some portion of the ground support functions currently carried out on Earth will need to move to the mission location.

3.3 Lessons Learned From the Apollo Missions

The lunar surface exploration missions carried out during the Apollo program are the closest example to the future planetary missions described in Section 2 of this report. As such, they represent a source of practical experience and lessons learned that should be incorporated into a set of functional capabilities for future EVA systems that will be used on other planetary surfaces.

In 1993, a study was conducted (Connors, Eppler, and Morrow, 1994) the main purpose of which was to identify those areas where the experiences of the Apollo lunar-surface astronauts led to basically similar conclusions and where planning lessons could be learned. Of the eleven surviving Apollo astronauts (at that time) who landed on the Moon, eight agreed to participate in this study. These participants were asked to comment on several different EVA hardware design and mission operations topics in the context of a future lunar mission that would be carried out with a crew of four and last for 45 days on the lunar surface.

The results of this study revealed a level of agreement among the Apollo lunar surface astronauts that can be summarized as follows:

1. Emphasis should be given to the integration of crew, equipment, and facilities as a total system.
2. All subsystem designs should be based on fundamental principles of simplicity and reliability. Given a trade-off, simplicity and reliability are to be preferred over added functionality.
3. The EVA hardware-related items most in need of improvement are the bulkiness/inflexibility of suits and the (inadequate) manipulability/dexterity of the gloves. [Subsequent improvements, resulting in the development of current advanced space suit system designs and in the Shuttle EMU Phase VI gloves, have addressed these concerns. See a discussion of these suits and gloves in Appendix C.]
4. Equipment should be designed to fit EVA task requirements and the training of crews should be on actual tasks, equipment, etc.
5. Future missions will require increased crew autonomy. Crews will need greater flexibility in operations, particularly in daily scheduling.
6. The habitat crew will play an increasingly important role in supporting EVA crew operations, replacing some of the activities previously performed by ground control.
7. High levels of maintainability and reparability must be designed into experiments as well as into equipment and facilities generally.
8. Extended missions will require ways to achieve and sustain high-level mental performance.

An abbreviated version of this study, providing additional background and supporting rationale for these conclusions, can be found in Appendix D of this report. The conclusions as stated here will be taken into account as the set of functional capabilities for future EVA systems are assembled later in this Section, incorporating those capabilities already identified in Section 2.

3.4 Expanded Functional Requirements and Mission Requirements

Based on the review of the current state of the art for EVA systems and on the review of recommendations from past missions, the functional requirements identified in the previous section have been refined. The following table uses the functional breakdown structure described in this section to organize the current capabilities of EVA systems and the refined functional requirements.

Table 3.4-1. A description of current state of the art and future needs for EVA systems

| Functional Capability | Current SOTA | Future Need |
|---|---|---|
| 1.1 Human Operated External Work System | <p>The U.S. STS/ISS EMU and the Russian Orlan DM (garments and life support) both designed for use in a microgravity, dust-free, relatively low-radiation, vacuum environment. The mass of these systems is relatively high compared to previous garments and life support, but durability and maintenance features are improved. Individual sortie duration is nominally six hours with additional contingency time available. Each suit is limited to 25 sorties (ISS usage) before (Earth-based) maintenance is required. Sortie distance is limited to the size of the spacecraft as all EVA personnel are tethered; the SAFER is available for emergencies only. With the exception of the RMS and Space Station Remote Manipulator System (SSRMS), no teleoperated devices are currently used in conjunction with humans on an EVA. A variety of powered and unpowered hand tools are available for use. (See Appendices B and C for examples.)</p> | <p>For future missions, the EVA garment must have sufficient mobility to allow the EVA crewmember to walk (the current EMU and Orlan garments do not have this capability), reach objects on the ground, and operate in a dusty, low-pressure or vacuum environment for at least 30 days and 15 sorties (based on envisioned early lunar surface missions) and up to 550 days and 200 sorties (based on envisioned Mars surface missions), with only maintenance and servicing available from the crew. (Note: The round trip duration of the early lunar mission is likely to be 40 days and the Mars mission is likely to be 1000 days.) Life support must have a similar life expectancy and number of sorties with all recharge, maintenance, and servicing performed by the crew in the field. The duration of each nominal sortie will be 8 hours. Microgravity missions are likely to be untethered with a TBD range (probably on the order of several 100 meters to a few kilometers). Surface missions (without transportation or safe havens) are likely to be limited to walk back distances using available life support (probably on the order of 15 km). Robotic devices that require only general supervision from humans to support specific EVA tasks will be needed to off-load some task from the humans or to augment the capabilities of humans.</p> |
| 1.2 Human Operated Internal Work System | <p>The state of the art for teleoperated robotic devices supporting EVAs is currently limited to robotic arms (the RMS and the SSRMS) with a few experimental devices tested in the lab or in space (e.g., AERCAM). (See Appendices B and C for examples.)</p> | <p>There will be an ongoing need for teleoperated devices such as the RMS and SSRMS, with advancements in strength, dexterity, and sensory feedback to the operator a necessity as payloads become larger (both mass and dimensions) and more sophisticated, particularly for supporting EVA missions in the microgravity environment. For EVA missions in all environments, mobility independent of the teleoperator's facility will become a necessity. Some merging or overlap of the EVA assistance robotic devices in Element</p> |

| | | |
|--|--|---|
| | | 1.1 with teleoperated devices in this Element will occur due to the overlap in assigned tasks and mission constraints on the total mass and number of hardware items that can be carried. Sensory feedback needs will expand to the level of a virtual presence for the human operator due to the nature of some of the tasks to which these devices will be assigned. Sensory feedback needs will include expanding the range of human senses (e.g., expanding the range of wavelengths visible to the human eye, expanding the range of frequencies audible to the human ear, etc.). |
| 1.3 Transportation System | Current EVA transportation is limited to that which can be accomplished in the microgravity environment and is typified by hand-over-hand translation or moving the EVA subject on the end of a mechanical arm, such as the RMS, with contingency free-flight maneuvering provided by the SAFER. However, there has been a demonstrated capability for short-range free flight in the microgravity environment (the MMU), for a walking EVA pressure garment (the Apollo A7L B), and for short-range planetary surface transportation (the LRV). It is assumed that this capability could be reconstituted without significant investment in technological advancement. (See Appendices B and C for examples.) | Future transportation needs will include short-range transportation on all environments. For those transportation systems that are unpressurized, the ability to recharge consumables (power, breathing gases, thermal control, etc.) in a PLSS will be needed. Long-range (which is synonymous with long-duration) transportation will also need the ability to recharge consumables of portable life support systems. In addition, these transportation systems will need an airlock capability (discussed further under Element 1.4) to allow crews to transit between the pressurized (it is assumed these long-range vehicles will be pressurized) and the outside environment and a capability to teleoperate robotic devices in conjunction with human EVAs and independent of them. |
| 1.4 Support Infrastructure System | Current EVA support infrastructure is represented by the STS and ISS airlock systems, with all other communication and navigation support handled by these larger vehicles. (See Appendices B and C for examples.) | Future EVA activities in the microgravity environment are likely to need similar capabilities to those used now, with provision made for somewhat longer distances of the transportation systems in use. On planetary surfaces, dust will become an issue and airlocks will need the capability to handle this material to minimize its introduction into the interior of a primary habitat. Long-range activities on planetary surfaces will introduce the need for communication relay and navigation support as EVA crews conduct sorties at ranges beyond direct line of sight. Operations at these longer ranges introduces the need for safe havens, to be used in contingency situations such as periods of increased radiation (e.g., solar storms) or unforeseen delays causing nominal consumables to be insufficient for a return to the main habitat. |
| 1.5 Ground-Based Support Systems (Earth) | This Element covers both testing/development and support of operational EVA sorties. A spectrum of | Of all the Elements in this breakdown structure, some element covered in this category will be in use during the entire 25 |

| | | |
|--|---|---|
| | <p>facilities covering different sizes and environmental conditions (thermal/vacuum, neutral buoyancy, parabolic flight, etc.) exist, both as a legacy of previous programs (e.g., Apollo) and contemporary programs, and are used for development and training. Simulation, operations concept development, and hardware development activities use indoor test facilities, outdoor ranges, and analog sites. Ground support for EVA operations has evolved over the years, keeping pace with other ground support functions provided to Space Shuttle and ISS EVA sorties. (See Appendices B and C for examples.)</p> | <p>years of development, testing and training leading up to the realization of the vision of EVA described above. A need for indoor test facilities, outdoor ranges, and analog sites will be ongoing for tests of operations and system compatibility. These sites and facilities will change as specific locations for specific missions are chosen, but representative sites and facilities will also be needed until these choices are made. In particular, facilities for long-duration simulations and tests, measured in 100s of days, will be needed to test concepts for some of the missions envisioned. A variety of environmental chambers, covering the range of environmental conditions found in free space and on planetary surfaces, will be needed as hardware is developed and tested. Similar long-duration testing requirements may also be levied on these development cycles. As round trip time delays for communication become significant, the emphasis for the ground support function may shift from immediate support and oversight to more long-range planning and troubleshooting. However, this premise must be tested and refined along with the rest of the EVA systems needed for the envisioned missions. This implies the need for a ground support simulation and development facility that will parallel the advancements and evolution of the EVA flight hardware and operations.</p> |
|--|---|---|

Examining these future needs as a whole indicates a significant advancement beyond current capabilities, plus an equally significant expansion of capabilities will be required to achieve this view of the future. EVA distances will expand from the range of a tether to many 10s or 100s of kilometers. Individual EVA sorties may not increase significantly above current capabilities, but the number of sorties and total duration of these sorties will increase dramatically. A single long-duration Mars surface mission will nearly equal the number of EVA sorties conducted by both the U.S. and Russia over the past 40 years and the total duration of these sorties will exceed the cumulative total of all EVA sorties to date by a significant amount. And, finally, the types of activities to be performed in this vision of the future will demand systems that are more durable, easier to use and easier to maintain than anything currently available. If all of these capabilities are achieved this will represent a revolution in the utility and productivity of EVA.

3.5 Summary

This section has presented a structure for discussing the functional requirements of future EVA systems. This structure was used to organize the results of a review of historic and current EVA systems. This review establishes the starting point for the EVA roadmap sought by the RASC program. In addition, functional requirements derived from a vision of EVA activities 25 years

in the future were refined to provide more specific, and in some cases measurable, functional requirements for these EVA systems. The next section will discuss system concepts that may satisfy these requirements. This will lead, finally, to a discussion of a possible roadmap for development of these systems.

4.0 REVOLUTIONARY CONCEPTS

The next step in the development of this advanced EVA roadmap was to identify revolutionary concepts for EVA systems, or technologies that could be used in EVA systems, that could achieve the functional requirements identified in the previous section. The identified concepts and technologies were then used as elements in the roadmap that will be described in the following section. Concepts and technologies were gathered from several sources. This was accomplished by means of an email solicitation sent to individuals and organizations working in this field as well as reviewing the literature for suitable material.

The remainder of this section will review the results obtained from the email solicitation as well as the results of a survey of the literature for advanced EVA concepts and technologies.

4.1 Concept Solicitation From the EVA Development Community

I invited 89 individuals (researchers, engineers, etc.) at 38 different organizations (listed in Table 4.1-1) that are active in EVA research and development to make inputs to this vision of the future or to suggest concepts that could lead to a realization of future EVA needs. Eleven individuals responded with general comments or specific technology or system concepts.

Table 4.1-1. Organizations invited to submit concepts or suggestions for revolutionary EVA concepts

| | |
|---|-------------------------------------|
| Aerospace Design and Development (ADD) | NASA Ames Research Center |
| Airlock, Inc. | NASA Glenn Research Center |
| Anthrotronix | NASA Goddard Space Flight Center |
| Aspen Systems | NASA Jet Propulsion Laboratory |
| AZ Tech | NASA Johnson Space Center |
| Battelle - Pacific Northwest Laboratory | NASA Langley Research Center |
| Baylor University | North Carolina State University |
| Boeing | Oceaneering Space Systems |
| Clemson University | Paragon |
| Creare | Rutgers University (Sapientis) |
| David Clark | Southwest Research Institute |
| Hamilton Sundstrand | TDA Research, Inc. |
| Honeywell | University of California, Berkley |
| Intelligent Automation, Inc. (IAI) | University of California, San Diego |
| ILC/Dover | University of Maryland |
| Lockheed Martin | University of Minnesota |
| Massachusetts Institute of Technology | University of Missouri |
| Measureland | University of Texas, Austin |
| | University of West Florida |
| | Zvezda (Moscow) |

Responses were received from nine of these organizations. The content of these responses can be summarized as follows:

- Use of shape memory alloys and elastomers (Airlock, Inc.)
- Suggested guidelines for roadmap development based on lessons learned from EVA development (David Clark Company, Inc.)
- Garment material that integrates the pressure restraint and thermal control functions (ILC/Dover)
- Modeling and simulation tools that can be used to understand and automate selected human activities (NASA Ames Research Center)
- A concept combining airlock and EVA garment functions (NASA Ames Research Center)
- Microcombustor-based power/propulsion concept (NASA Glenn Research Center)
- Use of O₂/Ar-based breathing gases (NASA Johnson Space Center, or JSC)
- Advanced thermal control technologies for garments and life support systems (TDA Research, Inc.)
- Advanced garment material technology (University of Minnesota)

A synthesis of common threads in these responses can be summarized as follows:

Due to the duration of these missions, the EVA architecture should favor modular (enhances maintenance and logistical requirements) systems, multipurpose (decreases the number of systems needed) systems, and passive rather than active (enhances reliability and maintenance) systems. A few of the examples cited include incorporating phase change materials or electro-active polymers into an EVA garment to handle heat exchange requirements, potentially eliminating the current liquid cooling garment and water sublimation cooling system.

Although often identified in the past, improvements in individual crewmember's performance by making systems lower in mass and simpler in operation. A few examples cited include custom designing various suit functionality into garment or systems at the molecular level (e.g., "nanomaterials") or via the incorporation of microelectromechanical systems. This type of advancement offers not only reduction in mass but also offers the potential for improved reliability by increasing redundancy and distributing systems as well as lowering suit inertia, thus improving maneuverability.

The destinations identified in the long-range vision, combined with the duration of the missions, leads to a need for improved radiation protection for EVA crews. A few examples cited identified radiation protection improvements to individual EVA systems to developing an EVA architecture that has progressive levels of increased radiation protection distributed among different systems.



One comment worthy of note was provided in the David Clark Company, Inc., response:

“Definition of EVA system concepts and technology requirements for future undefined missions is nearly impossible to obtain with any reasonable fidelity at this time. Definition of mission-specific environmental conditions and operational requirements are essential to making wise conceptual architecture and technology-needs decisions...”

Until specific mission destinations or objectives are set, caution should be taken in just how far to extrapolate from generic missions to system requirements and how much detail should be incorporated into a development roadmap.

4.2 Other Advanced or Revolutionary Concepts

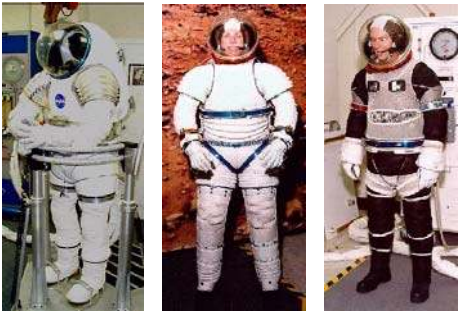
While these solicited results do not lead directly to specific EVA system concepts, they do provide some guidance for searching the literature for concepts that could meet the long-range vision of future missions that take into account these inputs provided by the research community. The following paragraphs describe selected future EVA system concepts that are consistent with both of these conditions. Additional details for these systems can be found in Appendices C and E of this report.

| 1.1 Human Operated External Work System | |
|--|---|
| <p>Experimental Garments. Work is currently under way to develop a garment that has sufficient mobility and light weight for use on planetary surfaces. Several garments are being used to test various concepts for garment components ranging from a predominantly “all-soft” (i.e., mostly fabric) garment that incorporates minimal bearings to concepts that incorporate significant quantities of graphite/epoxy composite layup and advanced bearings at the major joints. These suits still operate at low internal pressures (typically 24.1 kPa or 3.5 psi) dictating the use of pure oxygen for breathing gases. (see Appendix C)</p> |  |
| <p>Advanced Garment Concepts. From a physiological perspective, there are two essential factors the human body needs to function in a vacuum or near vacuum: oxygen and some external pressure. All EVA systems used to date have provided these two factors by means of a pressurized, airtight garment. An alternative is the use of a garment that provides external pressure mechanically in combination with a pressurized breathing apparatus. This alternative approach is generically referred to as a mechanical counter pressure suit. Such a radically different approach offers the potential for reducing the mass and complexity of current systems but introduces its own complexities and system requirements (see Appendix E).</p> |  |

Advanced PLSS. Portable life support systems for walking EVA suits have been (and will probably continue to be) carried as backpacks. Improvements continue to be made in performance and reliability of all the subsystems. But as mission durations become very long and as planetary surface operations become another venue for EVA several highly desirable features should also be taken into account: capable of being maintained by the crewmember, adaptable to technological changes, minimizes weight, and reduces volume. These subsystems and the approach used to package them also are candidates for single-person spacecraft (see “single-person spacecraft” below), pressurized rovers, and safe haven/emergency support systems. (See Appendix C.)



EVA Robotic Support Concepts. Experience gained during both Apollo missions and the many assembly, servicing and maintenance EVAs conducted from the Space Shuttle has indicated the desirability of varying degrees of assistance that could be reasonably supplied by robotic devices. The potential range of robotic support that could be supplied during future EVAs spans from the relatively simple task of transporting large and/or heavy objects for the EVA crew to relatively sophisticated tasks requiring a high degree of mobility and dexterity. Several of these systems are currently being tested and show potential for expanding both the type and sophistication of EVA tasks. (See Appendix C.)



1.2 Human Operated Internal Work System

AERCam. The utility of a remotely operated, mobile camera system has been found to be advantageous in several hostile (to humans) environments. Similar needs have been identified in the space environment. Adequate views that allow Orbiter intravehicular activity (IVA) crews to observe EVAs, inspect a location without an EVA, or view locations not visible by an EVA crewmember or remote manipulator system camera can be difficult if not impossible to obtain. The International Space Station (ISS) camera views are even more restricted due to the much larger structure to be viewed. One potential solution to address this need is the Autonomous Extravehicular Robotic Camera (AERCam) concept (see Appendix C).



Robonaut is a humanoid robot designed by the Robot Systems Technology Branch at JSC in a collaborative effort with DARPA. The Robonaut project seeks to develop and demonstrate a robotic system that can function as an EVA astronaut equivalent. While the depth and breadth of human performance is beyond the current state of the art in robotics, NASA targeted the reduced dexterity and performance of a suited astronaut as Robonaut’s design goals, specifically using the work envelope, ranges of motion, strength and endurance capabilities of space walking humans. (See Appendix C.)

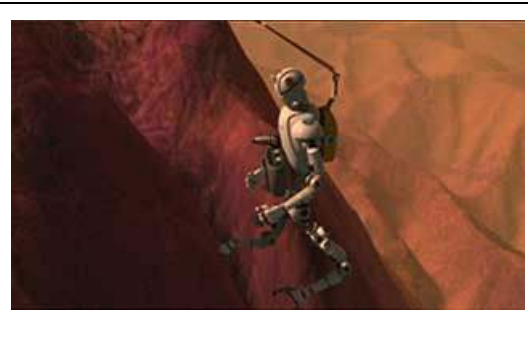

1.3 Transportation System

Single-Person Spacecraft. A single-person spacecraft occupies a niche between large, multifunction human spacecraft and EVA suits. This vehicle concept is built around a rigid pressure vessel large enough for a single person. The rigid pressure vessel allows for internal atmospheric pressures much higher than is typical for EVA suits (up to ambient pressures of larger spacecraft. This eliminates the need for a pure oxygen atmosphere, the associated time for prebreathing, and the added precautions that go with working at this pressure and in this atmosphere. (See Appendix E.)



Unpressurized rovers have been recognized as a means of expanding the area that humans can explore while on an EVA traverse. The Apollo Lunar Rover Vehicle (see Appendix B) greatly expanded the range of the Apollo surface traverses despite the fact that the A7L EVA suits had not been significantly modified. This functional capability will remain a necessity for future planetary surface traverses although their total compliment of functions will expand. (See Appendix E.)



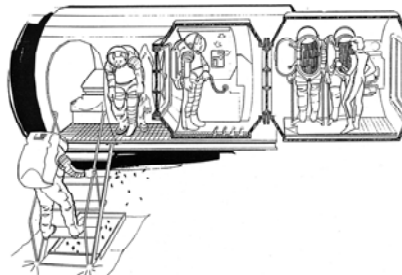

1.4 Support Infrastructure System

Dust Management. Another lesson learned from Apollo was the highly intrusive and abrasive nature of the dust. This same material could pose a long-term breathing hazard for the crew. Mars is also known to have very fine dust, although its abrasiveness and breathing hazard characteristics are yet to be determined. In both these locales, dust will inevitably coat EVA equipment surfaces and will be brought into the habitable spaces unless controlled. Garment materials and airlock architecture can be used to aid in controlling this material. (See Appendix E.)

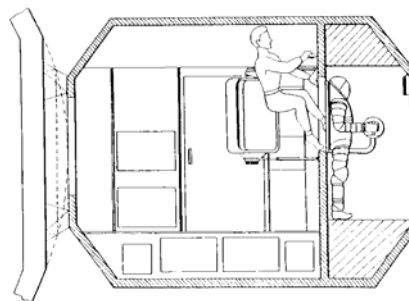

Suitport. For the mission durations and number of EVA sorties identified in the future vision of EVA, consumables or expendables can become a significant contribution to overall mass. Even though airlocks can be pumped down to a small fraction of their original atmosphere, losses still occur and make-up gases become an item that must be tracked as an expendable item. This is also an issue for pressurized rovers. Concepts have been proposed that can significantly reduce the lost breathing gas that occurs for each airlock cycle. One concept, known as a "suitport," actually connects the EVA suit to an outer wall. The crewmember enters the suit through an airtight hatch, so the only air loss is a minute amount around the hatch closure. (See Appendix E.)

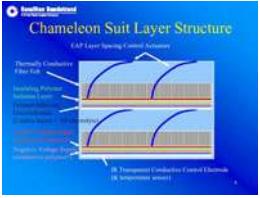

| 1.5 Ground-Based Support Systems (Earth) | |
|---|--|
| <p>High-Fidelity and Long-Duration Test Facilities. The use of high-fidelity and long-duration facilities for testing EVA systems and training crews will become increasingly important for future EVA missions. The INTEGRITY Project, and its facility (see Appendix C), is one example of a means by which testing of systems, procedures, and vehicle architectures associated with candidate human exploration missions that NASA may undertake in the future. In addition to EVA systems, INTEGRITY is intended to be a primary testing facility for habitability and human factors, life support and thermal systems, as well as crew health systems.</p> |  |
| <p>Advanced Control Centers. Advances in computing power, sensors, and communications are improving the situational awareness and ability to provide meaningful support by Earth-based control centers and backrooms. Mission definitions and operational concepts will define the type of support required from these centers. Facilities, such as the Exploration Planning and Operations Center (see Appendix C), will help test the validity of these concepts and the systems implementations.</p> |  |
| Cross-Cutting Technologies | |
| <p>There are many emerging technologies that could be applied in many of the systems mentioned above to achieve the goals of reducing mass or enhancing performance or providing entirely new capabilities. Two examples: Microelectromechanical systems offer the potential of substantially reducing size and mass (pictured at left) and new suit material concepts (e.g., the Chameleon suit; see Appendix E) integrates functionality helping to reduce the number of systems, interfaces, and mass.</p> |  |

4.3 Summary

Having described the current state of the art for EVA previously, the next step in the process of developing an EVA roadmap was to identify revolutionary systems or technologies that could bring EVA capabilities up to the level needed for missions envisioned 25 years in the future. An invitation to submit concepts to meet this need did yield some useful responses, but these responses were small in number. One of these responses seems to be indicative of the reason for the small number of responses, namely that the broad and generic nature of the missions described makes it difficult to provide specific concepts or technologies to meet the need. The responses received were, in some cases, combined as well as augmented with additional concepts and technologies gathered from the literature. Information about these concepts and technologies was summarized in this section, with additional information collected in Appendix E of this report. The next section will use the results from this section and previous sections to prepare a roadmap for EVA system development over the 25 years. This roadmap is discussed in the next section.

5.0 EVA TECHNOLOGIES AND DEVELOPMENT ROADMAP

Previous sections of this report have thus far described future missions envisioned by NASA, as they exist at the time this report was prepared, that define future EVA roles and activities. Also discussed were the evolution of EVA systems through current state of the art for these systems (including several examples of experimental systems currently in use) as well as lessons learned from flight experience using these EVA systems. Taking these future EVA roles and activities, combined with the current state of the art in EVA and lessons learned from previous EVA missions and systems, this section defines the endpoints of a technology development roadmap for the timeframe of interest to RASC.

5.1 Other Roadmaps

Before proceeding with development of an EVA roadmap based on the data gathered for this study, it is useful to review existing roadmaps for both EVA and other pertinent technologies.

Two recent study efforts that are relevant to this study of EVA systems were identified. The first is a study of space robotic technologies conducted under the sponsorship of the NASA Exploration Team (NEXT). The second is a roadmap prepared in the 1999–2000 timeframe for the HEDS Technology/Commercialization Initiative (HTCI) with input from the EVA community at JSC. Each of these will be briefly discussed here with applicability to the RASC roadmap noted where appropriate.

Space Robotics Technology Assessment Report. During the 1998–2000 timeframe, the NASA Exploration Team sought information regarding the current state of the art and future prospects for space robotics of the type that would be useful for future exploration missions, principally those involving humans. This directly overlaps a portion of the EVA system functional breakdown identified earlier in this report and thus represents a contributing element to the RASC roadmap. The following summary was adapted from several sections of this NEXT report.

The motivation for this report, which was commissioned by the NASA Exploration Team (NEXT), was to provide mission designers with appropriate expectations for the roles that robots might play in space missions in the next ten to twenty years. Mission designers can then determine the optimal mix of human and robotic talent to achieve their mission and science objectives.

To compile this report the authors defined several robot functionalities required to support two broad mission classes: planetary surface exploration and in-space operations. These functionalities are shown in Table 5.1-1. The authors decomposed the functionalities in Table 5.1-1 into a set of metrics that measure the current and future state of the art for each functionality. These metrics were then distributed to robotic experts (with hands-on experience) who were asked to rate each metric on a scale that ranged from that metric being within the current robotic state of the art to that metric requiring a fundamental breakthrough in robotic technology. In the middle of the scale were metrics that could be achieved in the next ten years with either nominal or intensive work. The authors then distilled the

responses to these metrics into a comprehensive set of current and predicted robotic capabilities.

Table 5.1-1. Space robotic functionalities

| In space operations | Planetary surface explorations |
|----------------------------|---|
| Assembly | Surface mobility |
| Maintenance | Instrument deployment and sample manipulation |
| Inspection | Science planning, perception and execution |
| Human EVA assistance | Human exploration assistance |

Several caveats are necessary before beginning. First, although this report, due to the report’s limited scope and funding, looks at robotic technology in isolation from the overall system infrastructure, this is not the right approach. Just as astronauts have a massive support structure (life support, training, ground control, etc.), which allows them to be successful, so too will robots need a similar support structure (special tools, robot-friendly components, robot pre-training, ground controllers, energy and repair facilities etc.) to be successful. Second, robot functionality and requirements should be derived from a set of science and mission objectives. By carefully designing a mission with robots and robot infrastructure in mind from the beginning NASA can make successful use of advanced robotic technology. Terrestrial examples like car factories, computer chip factories and automated farms demonstrate this.

In the next ten to twenty years the authors expect navigation and mobility to no longer be the constraining factors in planetary exploration – long traverses and access to most any locations on a planetary surface will be a given. And, based on the study results, the authors expect to see mission scientists able to interact directly with robots at the mission level. However, robotic performance at level of a human scientist in the field is and will continue to be a major challenge. Without significant breakthroughs, robot systems will perform only within narrowly defined areas of expertise and lack the general cognitive and perceptual abilities of a field scientist.

In the next ten to twenty years the authors expect the mechanical dexterity of assembly and maintenance robots to approach that of a space-suited human. However, the authors expect this capability to be fully realized only under teleoperation, which requires high-bandwidth, low-latency communication between the human and the robot. Autonomous assembly and maintenance in space will likely require careful systems engineering and constant monitoring from the ground. Automated inspection, on the other hand, seems well within the near-term robotic capabilities.

The information the authors gathered for this report paints a very optimistic picture of the potential of space robotics from those working most closely on the problems. For this picture to be realized NASA needs to invest in infrastructure and experiments that will advance the state of the art. Very little of the necessary future robotic capabilities require fundamental breakthroughs; most require only a

sustained engineering effort focused on developing methodologies and gaining experience in the role of robots in space exploration. Such a sustained effort will bear fruit in increasing the capability for a human virtual presence in space and pushing the boundaries of exploration.

(Adapted from NASA Exploration Team (NEXT), 2002.)

The data collected for this report are much more extensive than was possible to collect for this RASC report. The conclusions are also consistent with what information was gathered for this report.

HTCI EVA Roadmap. The HEDS Technology/Commercialization Initiative program was established during the late 1990s to focus on pre-competitive technologies and novel applications, supporting high-risk and high-payoff opportunities that demonstrate strong potential for commercial space benefits. The concepts encouraged under this program also focused on longer-term exploration and commercial space goals while developing and applying advanced technology in the non-space commercial marketplace and in nearer-term space applications.

To tackle these diverse technical challenges, the HTCI was initiated following a 6-month program formulation involving numerous NASA Enterprises, NASA Field Centers, universities, and commercial companies. In February 2001, HTCI issued a Cooperative Agreement Notice that yielded 152 proposals, from which 43 were recommended for funding in May 2001. Unfortunately, however, a few months later, HTCI funds were frozen, and then the funds were transferred to the ISS Program to cover budget issues.

One element of the HTCI was advanced EVA systems. The roadmap illustrated in Figure 5.1-1 is a slightly modified version of the EVA roadmap prepared under this program. (The only difference being in the top row where specific calendar years were changed to a number of years after this type of program was initiated.) This roadmap illustrates what could be accomplished with a modest level of funding (but greater than funding levels at the time this roadmap was prepared) and cooperation with other non-NASA organizations.

This roadmap's initial focus was on the EVA suit system (garment and PLSS) with a progressive increase in durability and reliability sufficient to support long-duration missions. The 50- to 100-day class mission would be representative of the in-space assembly and lunar surface missions described earlier in this report, while the 300- to 1000-day class missions would be representative of Mars surface missions and some types of asteroid missions. This initial stage of the roadmap would also have likely focused on an open architecture design, allowing components and subsystems from different sources to be used interchangeably. Larger systems, such as airlocks, rovers, and other EVA system elements, would have been started later in this process, given that their first use would also have occurred later than that of the suit system.

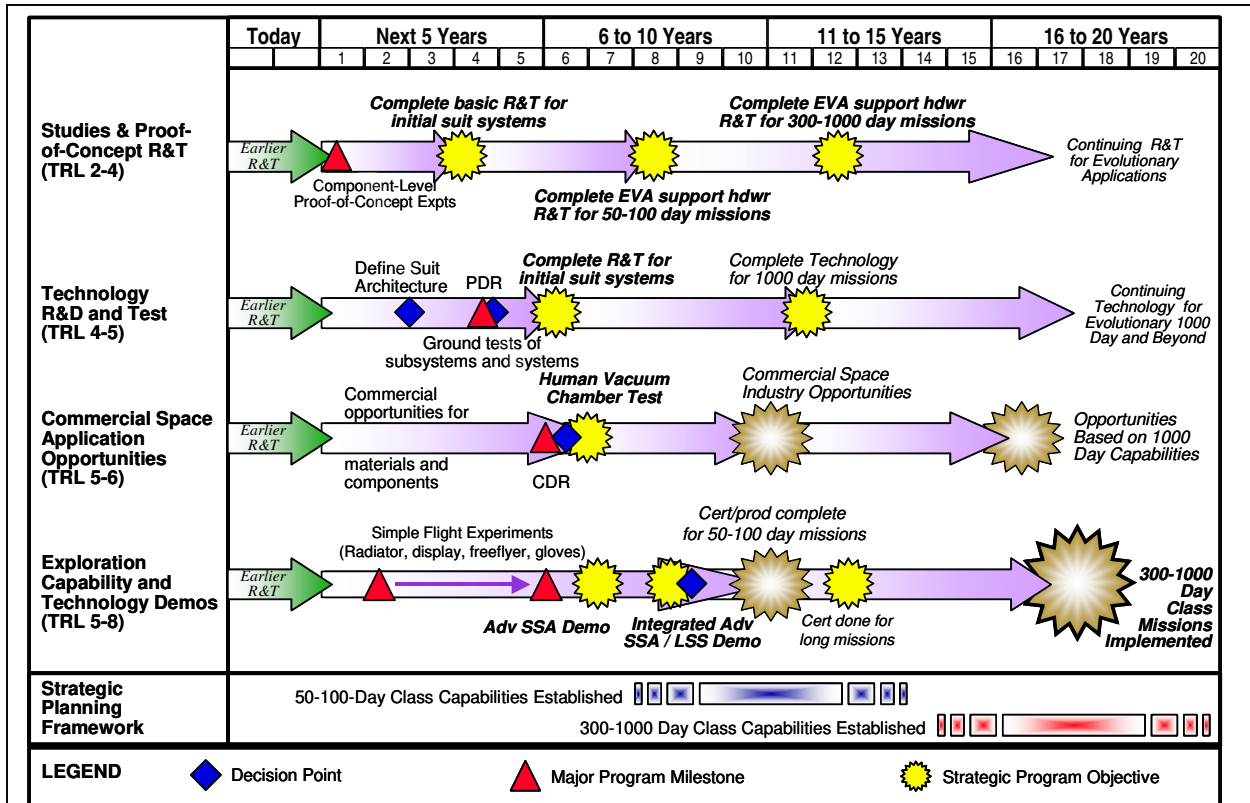

Figure 5.1-1. A general EVA roadmap for HTCI to support similar advanced EVA programs of the type envisioned for this study.

5.2 RASC Roadmap Recommendations

The purpose of a roadmap is to guide a journey from where a program is now to where it should go. It also helps to identify waypoints along this path. Both of these features help to determine how long it will take to complete this path for affixed amount of resources, or, conversely, what kind of resources are needed to complete the path if it is desirable to finish after a fixed amount of time. Regardless of the external constraints, one must adapt to unforeseen obstacles or serendipitous shortcuts along the way.

However, absent a definite destination or timeframe for reaching an objective, then any path is arguably as good as any other path. This also applies to roadmaps. The data collected for this study indicate a rich and diverse history of systems that have been developed to perform a variety of EVA tasks, indicating what is possible. However, the data gathered for this study also indicate a paucity of new concepts and technologies for advanced EVA missions—at least any that researchers are willing to discuss in this type of forum. As indicated by one of the respondents to the email solicitation sent to those working in this field, *“EVA system concepts are driven largely by mission design requirements and thus are the most difficult to define for a generic mission.”* The seeds for this conclusion are traceable to NASA’s future objectives as stated in its Strategic Plan—the starting point for this study.

Without *definite objectives* and a *timeframe* for accomplishing them, then the only approach may be to spread what resources are available across the broadest possible portfolio of technology options and concepts. This will at least allow limited progress to be made across a range of technologies and systems that may support some (or many) of the general destination and timeframe options that could result from choices made regarding the NASA Strategic Plan. Focusing too narrowly on any particular suite of technologies, given the lack of an equally focused set of destinations, missions, and a timetable, risks expending valuable resources on the wrong solution. Spreading resources across a broad range of technologies will, however, assuredly slow progress for any particular technology, but conversely this will also improve the chances of achieving a breakthrough in some technology. The predictability of a breakthrough in any one particular technology, regardless of the magnitude of resources devoted to it, is generally difficult if not impossible. But it is predictable that breakthrough, or revolutionary, technologies do require resources to occur at all. Unfortunately, only very small amounts of resources have been dedicated, recently, to advancing EVA concepts of any kind.

Revolutionary advances are not always made up solely of breakthroughs or radical changes. To accomplish the vision outlined in the early stages of this study will require a suite of technological and operational advances that can accomplish the following:

- Completing in one mission an equivalent number of EVA sortie hours as have been completed in all of the previous 40 years of EVA activity with this one mission being completed in less than one tenth (i.e., less than four years) of that time.
- Improvements in both maintenance techniques and system reliability that will increase by an order of magnitude the number of sorties allowed for EVA systems in nominal operations.
- Cutting the mass of an EVA suit (garment and PLSS) by at least a factor of 2 – 3 compared to current systems while retaining the same (or improved) functional capabilities.
- Increasing the range at which EVA activities are conducted away from a habitat (or equivalent safe location) by at least an order of magnitude over the best previous experience of the Apollo J series missions.

This capability will be accomplished through a combination of new (revolutionary) technologies, evolutionary advances in existing technologies, methodical testing through all stages of system development, and development of operational concepts that utilize the best features these systems have to offer. But progress toward success or failure of all of these factors can only be measured against a set of requirements to be met. At the present time, NASA's requirements for future EVA are very broad and generic. As a consequence, perhaps the best use of the results obtained from this study would be to construct a set of guidelines, or figures of merit, against which to compare any particular proposed technology or system concept and to prepare a sequencing of the functional needs derived from the Strategic Plan. Both of these would be described at a level that is consistent with the goals, objectives, and requirements of the NASA Strategic Plan.

5.3 Summary

Consequently, the following features should guide forward progress for advanced EVA development, consistent with the data gathered for this study and the current set of NASA mission objectives, destinations, and timetable for their completion:

- A suite of systems with the functional capabilities and performance for all elements in the EVA functional breakdown structure, as described in Table 3.4-1.
- The general sequence in which these systems are needed is: a lightweight, mobile (i.e., capable of walking) suit system (garment plus PLSS), robotic support (at least at the level of capability of an EVA Robotic Assistant, but preferably at the level of a Robonaut), and environment specific surface systems (airlocks, rovers, navigation/communication/safe haven).
- All systems should be designed with an open architecture and with modular components, to the maximum extent possible, to allow the systems to be used for extended lifetimes and to accommodate progressive upgrades.
- All systems should be compatible across all of the environments described, to the maximum extent possible.
- Systems should be certified in a progressive manner for on order of 50 days, then on order of 500 days of use independent of Earth-based support.

6.0 SUMMARY AND RECOMMENDATIONS

To summarize, this report documents the results of a study carried out as part of NASA's Revolutionary Aerospace Systems Concepts Program examining the future technology needs of EVAs.

The intent of this study was to produce a comprehensive report that identifies various design concepts for human-related advanced EVA systems necessary to achieve the goals of supporting future space exploration and development customers in free space and on planetary surfaces for space missions in the post-2020 timeframe. The design concepts studied and evaluated were not limited to anthropomorphic space suits, but included a wide range of human-enhancing EVA technologies as well as consideration of coordination and integration with advanced robotics. This was accomplished via a series of DRM descriptions, each focusing on a different location in the solar system and consistent with the stated objectives for future human missions found in the NASA Strategic Plan. Historical, current, and conceptual EVA systems that could contribute to accomplishing these missions were researched, organized, and documented. All of these elements contributed to the production of a comprehensive report on this topic.

The goal of the study effort was to establish a baseline technology "road map" that identifies and describes an investment and technical development strategy, including recommendations that will lead to future enhanced synergistic human/robot EVA operations. The eventual use of this study effort was intended to focus evolving performance capabilities of various EVA system elements toward the goal of providing high-performance human operational capabilities for a multitude of future space applications and destinations. The data collected for this study indicates a rich and diverse history of systems that have been developed to perform a variety of EVA tasks, indicating what is possible. However the data gathered for this study also indicates a paucity of new concepts and technologies for advanced EVA missions—at least any that researchers are willing to discuss in this type of forum. A key observation made by one of the respondents to an email solicitation sent to those working in this field was stated as: *“EVA system concepts are driven largely by mission design requirements and thus are the most difficult to define for a generic mission.”* Thus a single, specific road map for developing future EVA systems is only possible with a refinement of the mission requirements. To do otherwise makes the result highly dependent on the initial assumptions made, the validity of which are open to debate. The seeds for this conclusion are traceable to NASA's future objectives as stated in its Strategic Plan—the starting point for this study.

Consequently, the following features were identified as guidance for forward progress in advanced EVA system development:

- A suite of systems with the functional capabilities and performance for all elements in the EVA functional breakdown structure, as described in Table 3.4-1.
- The general sequence in which these systems are needed is: a lightweight, mobile (i.e., capable of walking) suit system (garment plus PLSS), robotic support (at least at the level of capability of an EVA Robotic Assistant but preferably at the level of a Robonaut), and environment specific surface systems (airlocks, rovers, navigation/communication/safe haven).

- All systems should be designed with an open architecture and with modular components, to the maximum extent possible, to allow the systems to be used for extended lifetimes and to accommodate progressive upgrades.
- All systems should be compatible across all of the environments described, to the maximum extent possible.
- Systems should be certified in a progressive manner for on order of 50 days, then on order of 500 days of use independent of Earth-based support.

These features were consistent with the data gathered for this study and the current set of NASA mission objectives, destinations, and timetable for their completion.

Recommendations. Relative to the development of a functional and practical EVA technology development road map, the top priority is the adoption of more specific future human mission objectives and a definitive timeframe for their accomplishment. Lacking this, development of a specific technology development road map at a level of detail beyond that just discussed may be problematic. Independent of this situation, funding beyond that needed to sustain the current EVA systems is dwindling (and this current system, the architecture for which is 25 years old, is becoming increasingly difficult to maintain as the certified components and technologies become obsolete and therefore no longer available from industry). This may be an appropriate opportunity for NASA to begin funding studies of an upgrade or replacement of the current EMU that also incorporates the guidelines for more advanced EVA systems using this report as one of the guiding documents. This would allow NASA to continue to provide necessary EVA support for Shuttle and ISS missions but also begin gaining experience with systems that will form the basis of advanced missions. If even some of the guidelines identified here (e.g., lighter weight or increased numbers of sorties between major servicing) are met by these advanced designs, the current programs will also realize the benefits through the life cycle of the system. Starting such a development process now will also help to maintain the industrial base and experienced personnel necessary to other systems in the future.

7.0 REFERENCES

- Allton, J. H. Catalog of Apollo Lunar Surface Geologic Sampling Tools and Containers, JSC-23454, NASA Johnson Space Center, Houston, Texas, also at <http://www.hq.nasa.gov/office/pao/History/alsj/tools/Welcome.html>, 1989.
- Connors, M., Eppler, D., and Morrow, D., Interviews with the Apollo Lunar Surface Astronauts in Support of Planning for EVA Systems Design, NASA Technical Memorandum 108846, NASA Ames Research Center, Moffet Field, CA, September, 1994.
- Duke, M., Hoffman, S., and Snook, K., The Lunar Surface Reference Mission: A Description of Human and Robotic Surface Activities, NASA Technical Publication 2003-210793, NASA Lyndon B. Johnson Space Center, Houston TX, July 2003.
- Eppler, D., "Geological Field Work and General Implications for Planetary EVA Suit Design," Internal Memo, NASA Johnson Space Center, Houston, TX, February 7, 1997.
- Feldman, W. C., Maurice, S., Lawrence, D. J., et al., "Evidence for Water Ice Near the Lunar Poles," J. Geophys. Res., Planets, **106**, #E10, 23232-23252, 2001.
- Gagge, A. P., Allen, S. C., and Marbarger, J. P., "Pressure Breathing," J. Aviat. Med. 16: 2-8, 1945.
- Graziosi, D., Stein, J., Ross, A. and Kosmo, J., "Phase VI Advanced EVA Glove Development and Certification for the International Space Station," ICES 2001-01-2163, 2001.
- Haldane, J. S., Respiration. Yale University Press, New Haven, 1920.
- Harris, G., Origins and Technology of the Advanced Extravehicular Space Suit, American Astronautical Society History Series, Volume 24, Univelt, Inc., San Diego, 2001.
- Henry, J. P., and Drury, D. R., Emergency Pressure Suit, AAF ATSC Engineering Division Memorandum Report No. TSEAA-660- 100, 1946.
- Hodgson, Edward W., "A Chameleon Suit to Liberate Human Exploration of Space Environments," NIAC Contract #07600-067, December 2001.
- Hoffman, S., The Mars Surface Reference Mission: A Description of Human and Robotic Surface Activities, NASA Technical Publication 2001-209371, NASA Lyndon B. Johnson Space Center, Houston TX, August 2001.
- Jacobs, H. J. and Karstens, A. E., Physiological Evaluation of the Partial Pressure Suit, Part I, USAF Memorandum Report No. M CREXD-696-1045, 1948.
- Kennedy, K and Harris, J. "Dust Control Research for SEI," in Proceedings of the Third International Conference on Engineering, Construction, and Operations in Space, Volume I, pp. 398-407, 31 May- 4 June, 1992.

- Kozloski, L., U.S. Space Gear, Smithsonian Institution Press, Washington DC, 1994.
- LExSWG, Lunar Surface Exploration Strategy, Lunar Exploration Science Working Group, University of Hawaii at Manoa. <http://www.pgd.hawaii.edu/lexswg/>, 1995.
- Lunar and Planetary Institute, New Views of the Moon II: Understanding the Moon Through the Integration of Diverse Datasets, <http://www.lpi.usra.edu/publications/meetingpubs.html> Lunar and Planetary Institute, Houston, Texas, 1998.
- McGuire, T. F., Physiology and Operational Comparison of MC-1 and MC-3 (MC-4) Partial Pressure Suits, WADC TR 57-536 (I). Wright Air Development Division, Wright-Patterson Air Force Base, Ohio, 1960.
- Mumma, M. J. and Smith, H. J., Astrophysics from the Moon, AIP Conference Proceedings **207**, American Institute of Physics, New York, 1990.
- NASA, 2003 Strategic Plan, National Aeronautics and Space Administration, Washington, DC, 2003.
- NASA Exploration Team (NEXT), Space Robotics Technology Assessment Report, L. Pedersen, Kortenkamp, D., Wettergreen, D., and Nourbakhsh, I., editors, December 2002.
- NRC, New Frontiers in the Solar System: An Integrated Exploration Strategy, National Research Council, Washington, DC, 2002.
- O'Connell, M., Slade, H., and Stinson, R., "Advanced Spacesuit Portable Life Support Packaging Concept Mock-Up Design & Development," ICES 1999-01-1995, 1999.
- Taylor, G. J. and Spudis, P. D. (eds.), Geoscience and a Lunar Base, NASA CP-3070, National Aeronautics and Space Administration, Washington, DC, 1990.
- Trevino, R. C., and Fullerton, R. K., "Online EVA Tool Catalog," www4.jsc.nasa.gov/org/df42/evatoolcatalog/index.htm, Johnson Space Center Mission Operations Directorate, EVA Robotics, and Crew Systems Operations Office, 1997.
- Van Susante, P. J., "Study towards construction and operations of large lunar telescopes." submitted to Advances in Space Research, 2002.
- Webb, P., Annis, J., The Principle of the Space Activity Suit, NASA CR-973, Dec 1967.
- Webb, P., Annis, J., Development of a Space Activity Suit, NASA CR-1892, Dec 1971.
- Wilson, C. L., Production of Gas in Human Tissues at Low Pressures, Report No. 61-105, School of Aerospace Medicine, USAF Aerospace Medical Center, Brooks Air Force Base, Texas, 1961.

APPENDIX A: EVA SYSTEM HIERARCHY

The following figures provide a graphical illustration of the next level of detail for the EVA functional breakdown structure initially described in Section 3 of this report. These lower-level breakdowns guided the categorization of EVA systems examined in this study and formed the basis for organizing Appendices C, D, and E that follow. Not all systems were broken down to the same level of detail given that not all systems have the same level of complexity or may not require the additional detail for purposes of this report. Each of the diagrams is self-explanatory for the purpose for which they were used in this report (i.e., organizational) and no further definition of the lowest level element was created.

A.1 Integrated EVA System Level

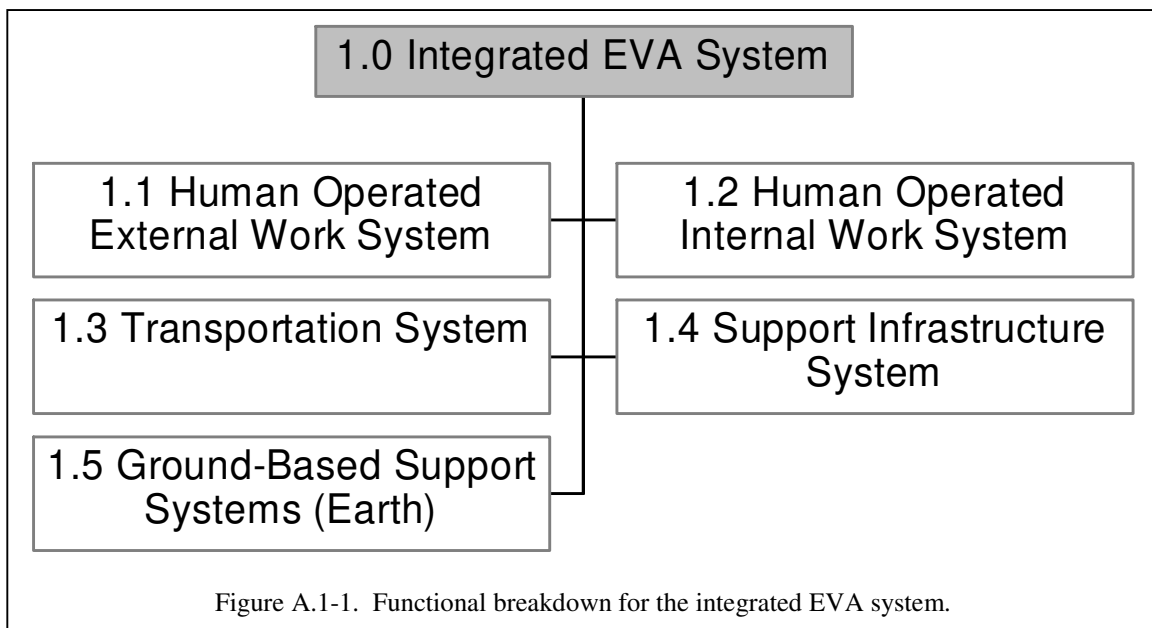

A.2 Human Operated External Work System

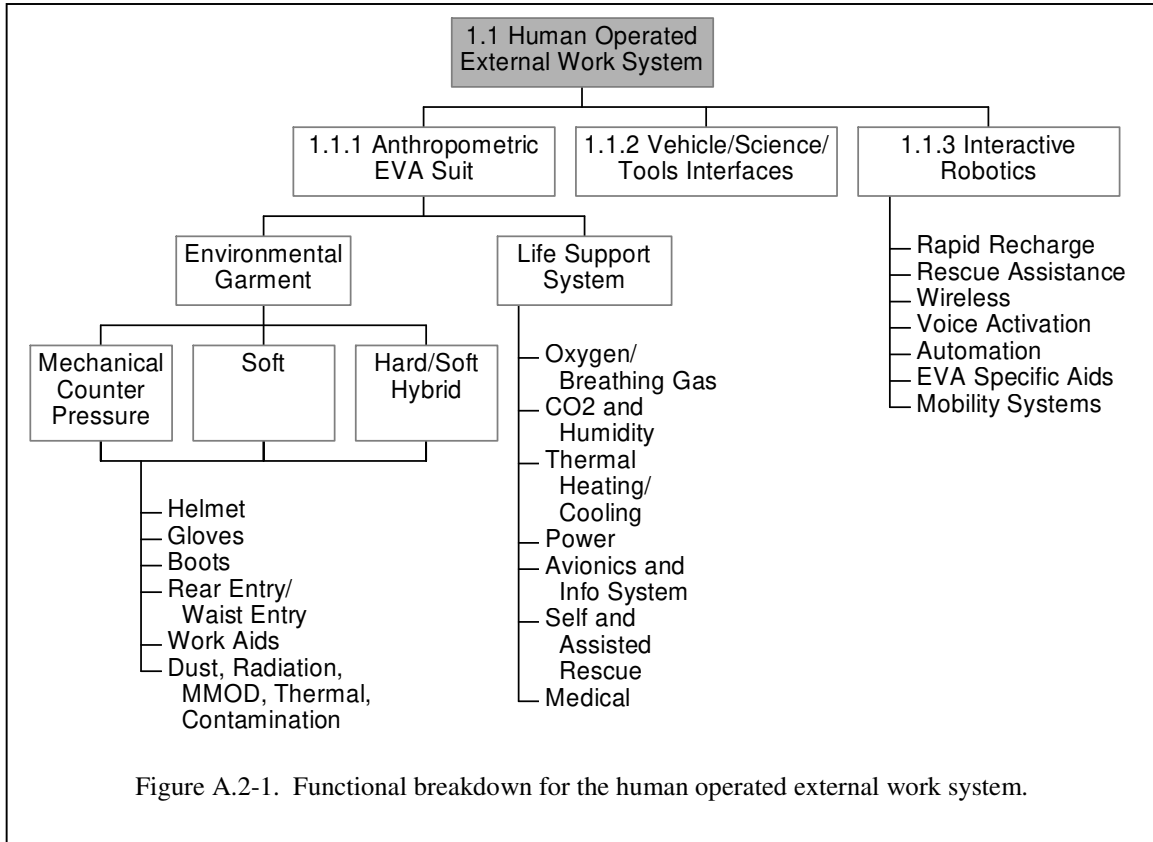

A.3 Human Operated Internal Work System

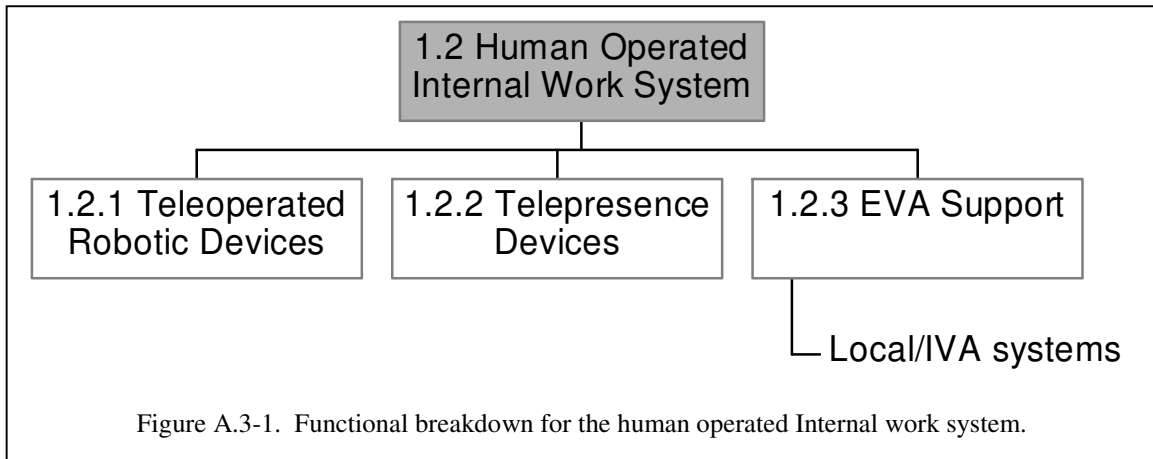

A.4 Transportation System

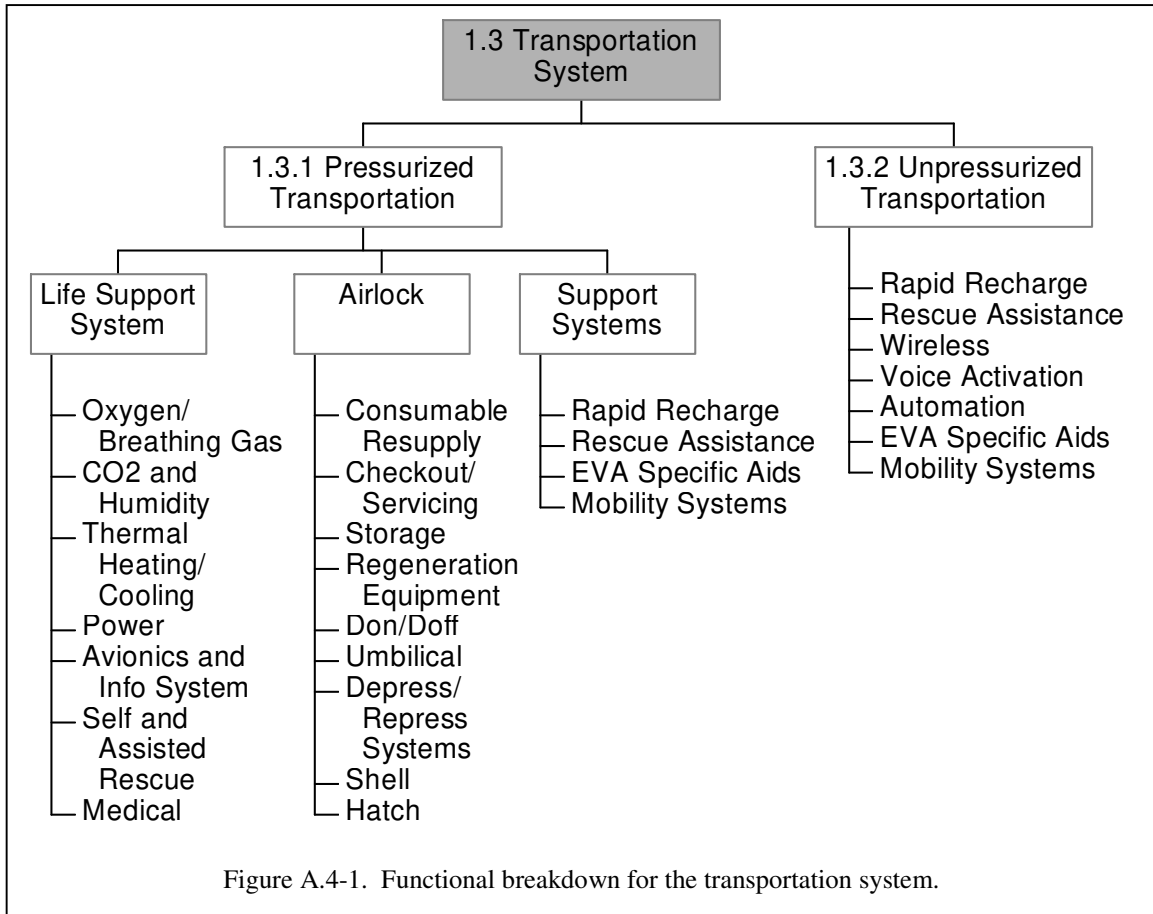

A.5 Support Infrastructure System

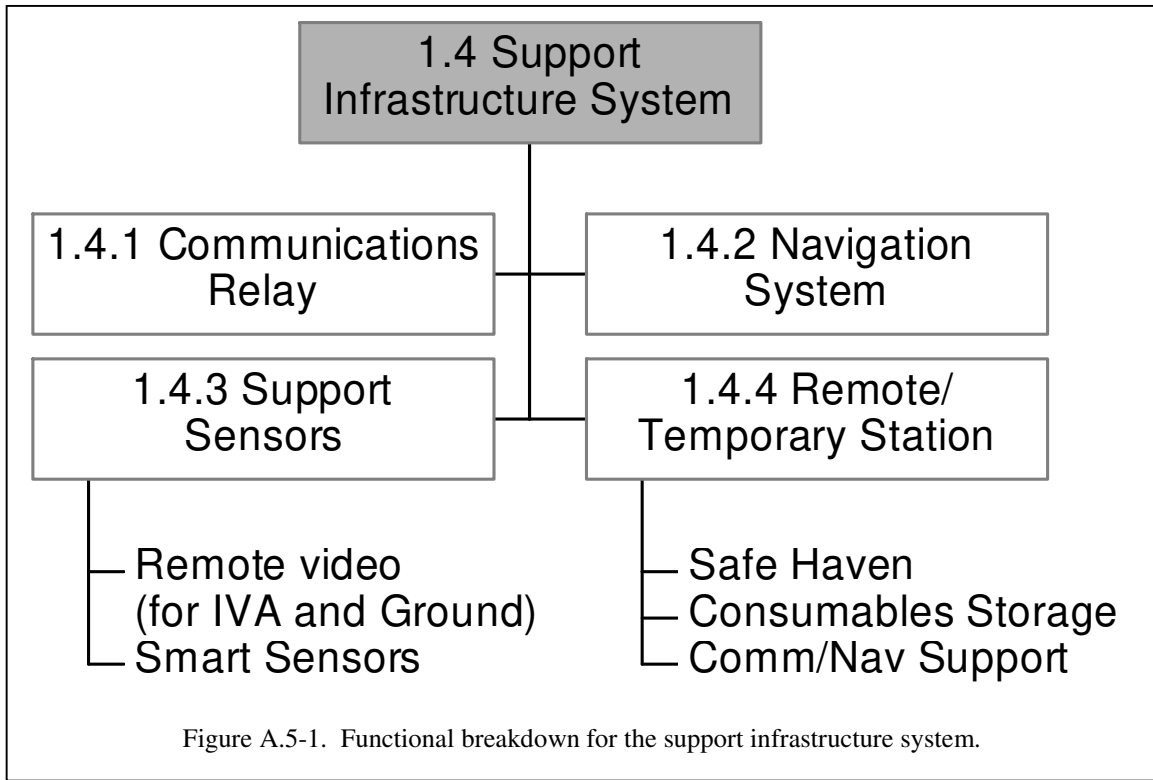

A.6 Ground-Based Support Systems (Earth)

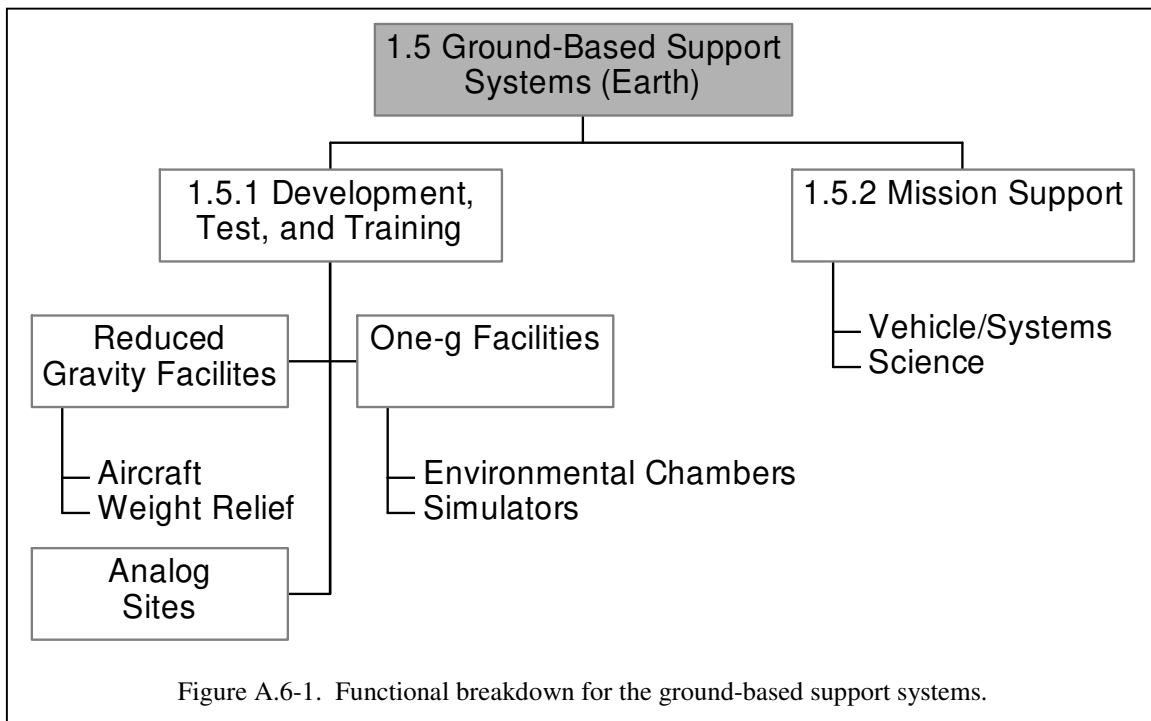

APPENDIX B: EVA SYSTEM HISTORY

This appendix provides a general history of the EVA systems described in Section 3 and Appendix A that have been developed to date. It is not the intent of this appendix to provide an exhaustive history of the development of these various systems, but rather to cover significant developments as a foundation for the discussion of future systems that follows.

The next two sections will describe EVA garments, including a discussion of gloves and boots, and portable life support, all items under Element 1.1 of the functional breakdown used in this study. This is followed by a discussion of teleoperated robotic devices (part of Element 1.2), transportation systems, including airlocks (Element 1.3), and support systems (Element 1.4). Other items in the functional breakdown are either current state of the art, and thus will be discussed in Appendix C, or have not been previously used.

B.1 EVA Garments and Portable Life Support

This section provides a brief history of pressure suit development and its use on U.S. space missions. The discussion covers suits used for the Mercury, Gemini, and Apollo programs, Skylab, and the Space Shuttle (the Shuttle EMU will be discussed in more detail in Appendix B). A more detailed description of these suits as well as suits used by other nations can be found in Harris (2001) and Kozlowski (1994). This section also discusses the PLSS, and an airlock without which EVA operations would be impossible.

General Background. In many ways, the early history of the development of full-pressure suits parallels the development of aviation. In 1920, J. S. Haldane, in his textbook, Respiration, considered the eventuality that aviators might someday fly above 40,000 ft and require protection against the respiratory problems that would inevitably result from the reduced barometric pressures at such altitudes. Haldane wrote:

. . . if it were required to go much above 40,000 feet and to a barometric pressure below 130 mm mercury, it would be necessary to enclose the airman in an air-tight dress, somewhat similar to a diving dress, but capable of resisting an internal pressure of say 130 mm of mercury. This dress would be so arranged that even in a complete vacuum the contained oxygen would still have a pressure of 130 mm. There would then be no physiological limit to the height obtainable. (Haldane (1920))

Haldane was, of course, talking about the protection of flyers in airplanes, but his idea, which was not even tried until 1933, became the basis for the pressure suits that in the 1960s enabled man to orbit the Earth in a spacecraft and eventually to walk on the Moon.

In 1933, Mark Ridge, an American balloonist, wearing a modified British diving suit, successfully underwent decompression in a chamber to 17 mm Hg, equivalent to an altitude of 84,000 ft. In the following year, the American aviator Wiley Post, realizing that high altitude might improve his plane's speed, attained an altitude of 38,000 ft while wearing the third in a series of pressure suits produced by B. F. Goodrich Co. During the same period, two Royal Air Force pilots named Swain and Adam flew a special Bristol 138 aircraft to record altitudes of

more than 49,000 and 53,000 ft, respectively. They wore Mark Ridge's pressure suit made by the Siebe-Gorman Company in England. Other pressure garments of various types had been produced and tested in Europe by 1939; however, all pressure suits produced up to this time had many things in common. Basically, they all consisted of rubberized canvas material pressurized with oxygen. One version used by Pezzi of the Italian Air Force was electrically heated and even had metal alloy restraint devices to prevent ballooning. These early suits were awkward, hot, difficult to put on and take off, and made the wearer virtually immobile.

Just prior to World War II, pressurized aircraft cabins were developed, and it seemed that the cumbersome full-pressure suit would no longer be needed for high-altitude flights. But during the war, military aircraft were designed to fly above 40,000 ft, and some sort of pressure garment was necessary as a backup in case cabin pressure failed.



Figure B.1-1. Wiley Post and his pressurized flying suit.

In 1945 Gage, Allen, and Marbarger (1945), who had studied the effects of explosive decompression, reported that by breathing oxygen under a few mm Hg of positive pressure from a mask, men could survive the reduced pressure of high altitudes without a protective garment. Only 15 mm Hg of positive pressure oxygen was needed for altitudes up to 45,000 ft. This led to the concept of using positive pressure breathing, previously restricted to clinical use, as a protective device in aircraft, and eventually to the development of the partial—as opposed to full—pressure garment. With higher positive pressures (more than 30 mm Hg) unless compensatory counterpressure was applied to the body, there was difficulty in breathing, discomfort in the head and neck, and danger of circulatory collapse. The addition of breathing bladders over the chest, as in the RCAF and RAF vests, permitted breathing up to 30 mm Hg pressure for significantly long periods from an oxygen mask; however, there was still discomfort in the face and neck. Full helmets were then added to relieve this discomfort, but now the problem became one of circulatory collapse. The raised intrapulmonary pressure caused a marked reduction in venous return to the heart, blood pooling, and then syncope. A helmet and a full trunk bladder extending down over the upper thighs—the RAF jerkin—permitted higher breathing pressures for protection in higher altitudes, but for short periods. It was found that, for exposures beyond a few minutes, it was essential to add bladders to the legs and then to the arms, which brought on restriction of mobility.

By 1946, American research in positive pressure breathing and mechanical pressure culminated in the partial-pressure suit introduced by Henry and Drury (1946). Added to trunk bladders and the helmet were gas-filled tubes running down the arms and legs, which were tied to the suit material with tapes. When these “capstan” tubes were inflated, the inelastic and tightly fitted

cloth of the arms and legs was drawn up tight, thereby applying mechanical pressure to the limbs. An evaluation of the suit was reported by Jacobs and Karstens in 1948 (Jacobs and Karstens (1948)). The suit was intended to give protection against decompression in high-altitude aircraft, allowing time to bring the craft down to safe altitudes. For such short periods, nearly complete coverage of the trunk with breathing bladders proved useful, but these bladders plus the anti-G suit bladders on the legs made the pilot hot, since perspiration could not evaporate. The full bladders were used in a later suit by McGuire (1960). Temperature regulation continued to be a severe problem, since more than 50% of the skin was covered by impermeable layers. The suit was useful in aircraft operating at very high altitudes (Wilson (1961)), and it had been tested in a chamber to 198,000 ft (McGuire (1960)), but it was never intended to be used by an active man in a space vacuum.

Since partial-pressure suits cannot be used for extended periods at very low ambient pressures, when the exploration of space became feasible in the 1960s it was realized that full-pressure suits would be required to protect the astronauts. However, the requirements of wartime flying had caused all attention to be put on the development of partial-pressure garments, so limited progress was made in full-pressure suit development for some 15 years following Wiley Post's first usable suit. B. F. Goodrich did develop another suit in 1943, and by 1950, the David Clark Company was making a full-pressure suit, but it lacked an automatic pressurization system and had to be manually adjusted to the desired pressure. Mobility had not been improved much. In 1952, an automatic pressurization device was developed, and since then the drive has been in the direction of increased mobility as well as better temperature and humidity control.

During the 30 years between Wiley Post's experiments and the beginning of the Mercury Program, pressure suits evolved in many ways and technical manufacturing help was gained from companies that made armor, diving suits, galoshes, and even girdles and corsets. [As discussed above] designers learned in their search for the perfect suit that it was not necessary to provide full sea-level pressure. A suit pressure of 24.13 kilopascals (3.5 psi; sea level – 101 kilopascals or 14.7 psi) would suffice quite nicely if the wearer breathed pure oxygen. Supplying pure oxygen at this low pressure actually provides the breather with more oxygen than an unsuited person breathes at sea level. (Only one-fifth of the air at sea level is oxygen.)

Various techniques were used for constructing pressure garments. Some approaches employed a rigid layer with special joints of rings or cables or some other device to permit limb movements. Others used non-stretch fabrics – laced-up corset fashion.

Project Mercury. By the time NASA began the Mercury manned spaceflight program, the best full-pressure suit design consisted of an inner gas-bladder layer of neoprene-coated fabric and an outer restraint layer of aluminized nylon. The first layer retained pure oxygen at 34.5 kilopascals (5.0 psi); the second layer prevented the first from expanding like a balloon. This second fabric restraint layer directed the oxygen pressure inward on the astronaut. The limbs of the suit did not bend in a hinge fashion as do human arms and legs. Instead, the fabric arms and legs bent in a gentle curve, which restricted movement. When the astronaut moved one of his arms, the bending creased or folded the fabric inward near the joints, decreasing the volume of the suit and increasing its total pressure slightly. Fortunately for the comfort of the Mercury astronauts, the Mercury suit was designed to serve only as a pressure backup if the spacecraft cabin

decompressed. No Mercury capsule ever lost pressure during a mission, and the suits remained uninflated.

Project Gemini. The six flights of the Mercury series were followed by ten flights in the Gemini program. Suit designers were faced with new problems. Not only would a Gemini suit have to serve as a pressure backup to the spacecraft cabin, but also as an escape suit if ejection seats had to be fired for an aborted launch and as an EMU for EVAs. To increase mobility and comfort of the suit for long-term wear, designers departed from the Mercury suit concept. Instead of fabric joints, they chose a construction that employed a bladder restrained by a net. The bladder was an anthropomorphically shaped layer of neoprene-coated nylon. That was covered in turn with a layer of

Teflon®-coated nylon netting. The netting, slightly smaller than the pressure bladder, limited inflation of the bladder and retained the pressure load in much the same way automobile tires retained the load in inner tubes in the days before tubeless tires. The new spacesuit featured improved mobility in the shoulders and arms and was more comfortable when worn unpressurized during spaceflights lasting as long as 14 days.

The first Gemini astronaut to leave his vehicle was Edward White, II. White exited from the Gemini 4 space capsule on June 3, 1965—just a few months after Alexei Leonov made the first Soviet space walk. For a half-hour, White tumbled and rolled in space, connected to the capsule only by an oxygen-feed hose that served secondary functions as a tether line and a communication link with the capsule. On his EVA, White used a small handheld propulsion gun for maneuvering in space (discussed below).



Figure B.1-3. Ed White on first U.S. EVA. (NASA Photo)



Figure B.1-2. Project Mercury pressure suit. (NASA Photo)

Upon completion of the Gemini program, NASA astronauts had logged nearly 12 additional hours of EVA experience. Approximately one-half of that time was spent merely standing up through the open hatch.

One of the most important lessons learned during the Gemini program was that EVAs

were not as simple as they looked. Moving around in space required a great deal of work. The work could be lessened, however, by extensive training on Earth. The most effective training took place underwater. Wearing specially weighted spacesuits while in a deep tank of water gave later Gemini crewmembers adequate practice in maneuvers they would soon perform in space. It was also learned that a better method of cooling the astronaut was required. The gas cooling system could not remove heat and moisture as rapidly as the astronaut produced them, and the inside of the helmet visor quickly fogged over, making it difficult to see.

Project Apollo. Following Gemini, the Apollo program added a new dimension in spacesuit design because actual space walks (on the surface of the Moon) were now to occur for the first time. As with Mercury and Gemini space garments, Apollo suits had to serve as a backup pressure system to the space capsule. Besides allowing flexibility in the shoulder and arm areas, they also had to permit movements of the legs and waist. Astronauts needed to be able to bend and stoop to pick up samples on the Moon. Suits had to function both in microgravity and in the one-sixth gravity of the Moon's surface. Furthermore, when walking on the Moon, Apollo astronauts needed the flexibility to roam freely without dragging a cumbersome combination oxygen line and tether. A self-contained PLSS was needed.

The Apollo spacesuit began with a garment that used water as a coolant. The garment, similar to long johns but laced with a network of thin-walled plastic tubing, circulated cooling water around the astronaut to prevent overheating. A multilayered pressure garment was worn on top of the cooling suit. The innermost layer of this garment was a comfort layer of lightweight nylon with fabric ventilation ducts. On top of this was a layer of neoprene-coated nylon surrounded by a nylon restraint layer. This layer contained the pressure inside the suit. Improved mobility was achieved by bellow-like joints of formed rubber with built-in restraint cables at the waist, elbows, shoulders, wrist, knees, and ankles. On top of the pressure layer were five layers of aluminized Mylar® for heat protection, mixed with four spacing layers of non-woven Dacron®. Above these were two layers of Kapton and beta marquisette for additional thermal protection and a nonflammable and abrasion-protective layer of Teflon®-coated filament beta cloth. The outermost layer of the suit was white Teflon® cloth. The last two layers were flame resistant. In total, the suit layers provided pressure, served as a protection against heat and cold, and protected the wearer against micrometeoroid impacts and the wear and tear of walking on the Moon. Capping off the suit was a communications headset and a clear polycarbonate-plastic pressure helmet. Slipped over the top of the helmet was an assembly consisting of Sun-filtering visors and adjustable blinders for sunlight protection. The final items of the Apollo spacesuit were lunar protective boots, a PLSS, and custom-sized gloves with molded silicone-rubber fingertips that provided some degree of fingertip sensitivity in handling equipment. The topic of boots and gloves is particularly important for carrying out EVAs and is discussed in more detail in the following section.

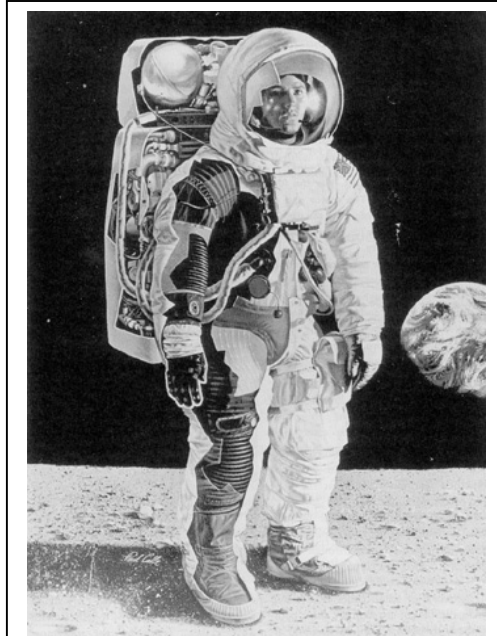

Figure B.1-4. The Apollo A7L-B suit. (Smithsonian Institution photo 92-616).

The life-support system, a backpack unit, provided oxygen for breathing and pressurization, water for cooling, and radio communications for lunar surface excursions lasting up to eight hours. Furthermore, back inside the lunar lander, the life-support system could be recharged with more oxygen and battery power for additional Moonwalks.

During the Apollo program, 12 astronauts spent a total of 161 hours of EVA on the Moon's surface. Additional EVAs were spent in microgravity while the astronauts were in transit from the Moon to Earth. During a total of four hours, one astronaut, the command module pilot, left the capsule to retrieve photographic film. There was no need for the PLSS away from the Moon, as those astronauts were connected to the spacecraft by umbilical tether lines supplying them with oxygen.

Skylab. Skylab was NASA's first space station, launched in 1973, six months after the last Apollo Moon landing. The Skylab EMU was a simplified version of the Apollo suits. There was no need for the PLSS because the crewmember was attached to the station by an umbilical tether that supplied oxygen and cooling water. An astronaut life-support assembly, consisting of a pressure-control unit and an attachment for the tether, was worn on the chest, and an emergency oxygen package containing two supply bottles was attached to the right upper leg. A simplified visor assembly was worn over the pressure helmet. Skylab astronauts logged 17.5 hours of planned EVA for film and experiment retrieval and 65 hours of unplanned EVA for station repairs.

Space Shuttle. As NASA changed from launching astronauts on expendable rockets to the Space Shuttle system with its reusable Orbiter and solid rocket boosters, spacesuit engineers began developing a reusable EMU. Previously, all spacesuits were one-time garments. Spacesuits were custom-built to each astronaut's body size. In the Apollo program, for example, each astronaut had three custom suits: one for flight, one for training, and one for flight backup. Shuttle suits, however, are tailored from a stock of standard-size parts to fit astronauts with a wide range of measurements.

In constructing the Shuttle spacesuit, designers were able to concentrate all their designs toward a single function: going EVA. Suits from earlier manned spaceflight programs had to serve multiple functions. They had to provide backup pressure in case of cabin pressure failure and, on Gemini missions, protection if ejection became necessary during launch. They also had to provide an environment for EVA in microgravity and in low gravity while walking on the Moon (Apollo missions). Suits were worn during liftoff and reentry and had to be comfortable under the high-G forces experienced during acceleration and deceleration. Shuttle suits are worn only when it is time to venture outside the Orbiter cabin. At other times,

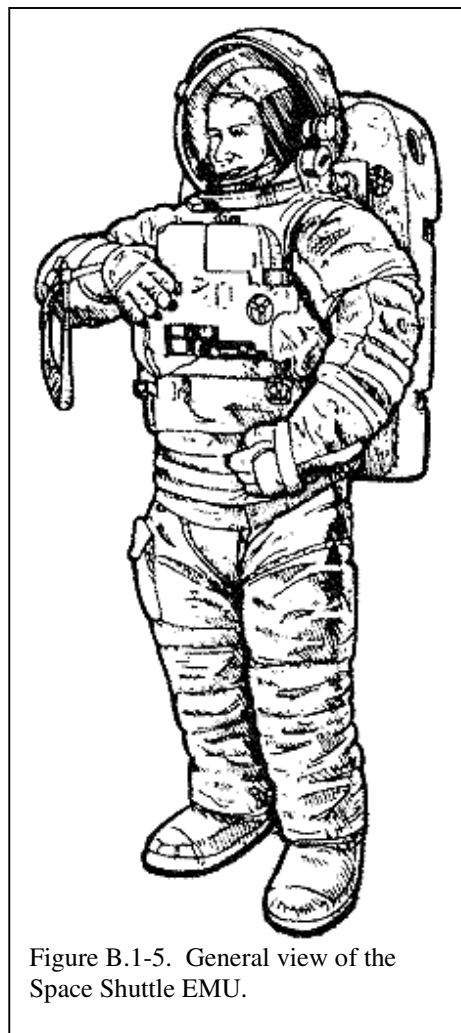

Figure B.1-5. General view of the Space Shuttle EMU.

crewmembers wear comfortable shirts and slacks, or shorts. For launch and reentry, special orange-colored [partial-pressure] flight suits with helmets are worn.

(Note; the previous discussion of EVA garments was derived from two sources: <http://quest.arc.nasa.gov/space/teachers/suited/4space1.html> accessed on Nov 14, 2002 and from Webb, P., and Annis, J., 1971.)

Boots and Gloves. Boots and gloves have received particular attention in the history and continuing development of EVA systems. Depending on the task to be performed, both can require a degree of mobility and dexterity to allow the suited crewmember to perform EVA tasks. While boots have not presented a particularly difficult design challenge, gloves remain an area of ongoing evolution to accommodate the many functions performed by the human hand, such as gripping multiple-sized objects at differing angles or sensory feedback for temperature and texture. Much of the feedback received from astronauts regards their desire for a glove that stays in place, allows gripping without significantly extra effort, and provides an acceptable level of dexterity and feedback. This goal continues to be a high priority. From a historical perspective, the boots and gloves developed for the Apollo program represented something of a plateau in terms of the level of sophistication and the functionality that must be provided.



Figure B.1-6. Apollo EVA glove assembly. (Photo courtesy S. Hoffman).

Fundamentally, all glove development to date has included the following three elements. From the hand outward, the first layer of the glove is the air-tight bladder. This layer is designed to retain the pressurized environment of the glove. The next layer is the restraint. This component of the glove is responsible for carrying all pressure and crew-induced loads during operational use. The final outer layer is the thermal and micrometeoroid garment (TMG). The function of this layer is to provide a buffer from thermal swings and to guard against the impact of hypervelocity, micrometeoroid particles. Boots required the same functionality, provided in the same ordering of the layers, but typically used different construction.

Apollo EVA gloves consisted of an inner and an outer glove. As seen in Figure B.1-6, the inner gloves (at left in Figure B.1-6) consisted of integral structural restraint and pressure bladders, molded from casts of the crewmen's hands. Pressure-sealing disconnects, similar to the helmet-to-suit connection, attached the gloves to the spacesuit arms. The outer gloves (at right in Figure B.1-6) consisted of integrated thermal covering of five to seven alternating layers of aluminized Mylar and Darcon scrim and an external layer of Chromel-R, a metal-woven fabric qualified to withstand heat to 650°C (1,200°F). Thumb and fingertips were molded of silicone rubber to permit a degree of sensitivity and "feel."

Lunar boots resembled oversized galoshes with soles of molded silicon rubber and extra thermal shielding between the lunar boot and the integral torso-limb suit boot. The outer layer of shielding, which acted as insulation, consisted of Teflon-coated Beta cloth, two alternate layers

of Kapton spaced with Beta felt. A layer of Chromel-R on the upper sidewalls of the boots protected against abrasion.

The Apollo suits were constantly modified as dictated by continuing research and in response to astronauts' complaints. The original hard boots were redesigned to an all-soft construction that provided increased flexibility while walking. The new gloves gave the wearer a much better grip because the metallic Chromel-R layer covering the palm was coated with a slip-resistant silicon dispersion compound. This compound also covered the high-strength nylon-tricot-covered fingertips.

In subsequent interviews with those Apollo astronauts who walked on the Moon (Connors et al., (1994); see further discussion in Appendix D regarding these interviews) during the 1990s, there was little mention of any problems with the boots used on these missions. However, there was consensus that gloves/hand dexterity was among the most important EVA improvements needed. There was a restrained approval of the changes that have been made in the gloves since Apollo but the general feeling was that these improvements were not nearly enough.

Virtually all respondents reported that the gloves they had worn on Apollo imposed limitations on movement of the fingers, hands, and forearms. These limitations ranged from lack of adequate tactility and feedback, to reduced performance and muscle fatigue, to sores and bruises. Most found that muscle fatigue disappeared overnight and thought that it did not pose a cumulative threat. Several suggestions were offered, including customization and careful fitting to anticipate pressurization changes and exercise and training to prepare the hands for an extended-duration mission.

Portable Life Support. The Apollo PLSS was the first self-contained portable life support system qualified for space use. This system was developed to give the Apollo astronauts the ability to move freely about the lunar surface without the constraint of a tether connected to a spacecraft life support system (the approach used for the Gemini missions). First tested on Apollo 9 (an Earth orbiting mission), this system was used on all subsequent lunar surface missions and was the basis for the primary life support system used for the Space Shuttle EMU.

The Apollo PLSS provided six primary functions to the astronaut during an EVA: breathing air, thermal control, power, communication, biomedical monitoring, and a backup emergency capability should primary subsystems fail. The system is divided physically into three components: the PLSS itself (mounted on the astronaut's back), the Oxygen Purge System (OPS) (mounted on top of the PLSS), and the chest-mounted Remote Control Unit.

The PLSS provided all of the primary functions listed above. Pure oxygen was supplied from high-pressure storage bottles for breathing and to pressurize the suit to at least 25.5 kPa (3.7 psi). On the return circuit, this gas, now a mixture of oxygen, exhaled carbon dioxide, and water vapor

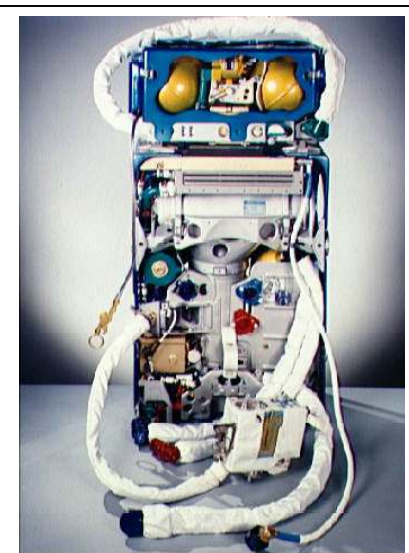

Figure B.1-7. The Apollo PLSS showing the OPS (in blue on top), the PLSS (in the center), and the Remote Control Unit (in the lower foreground). (MSC photo S70-39666).

that has been warmed by the heat generated by the astronaut's body, was cooled in a heat exchanger (reducing both heat and humidity) before being passed through a lithium hydroxide canister to eliminate carbon dioxide. The remaining oxygen was augmented with additional gas from the storage bottles (to maintain the proper pressure) and returned to the suit. Water circulated through the liquid-cooled garment, “long johns” with plastic tubing sewn into it and worn by the astronauts, to remove body heat. This water also flows through the heat exchanger where it gives up heat to a separate supply of cooling feedwater. The cooling feedwater flows into a sublimator, where it ultimately sublimates into space and carries away excess heat. A single battery supplied power with sufficient capacity for a single EVA. The first battery, installed before launch, was changed before the second EVA as part of the EVA prep procedure. Spare batteries were stored in the lower (unpressurized) section of the lunar lander, and a fresh set was brought into the cabin as part of the EVA close-out activities. All of these functions operated “open loop” in that oxygen, cooling feedwater, and batteries must be replenished after each EVA.

The OPS was completely independent from the PLSS and was intended for emergency use should the PLSS fail. Should such a failure occur, the astronaut would activate the OPS using a lever on the side of the Remote Control Unit. Oxygen would flow into the suit from the OPS tanks. Because the PLSS was now not recirculating the breathing gas, this oxygen was simply vented from the suit. Pulling the “red apple,” which was located on the front right side of the astronaut’s suit, pulled a safety pin from the Oxygen Purge Valve. Once the pin was pulled, the astronaut could then open the valve and OPS oxygen was vented to space. The OPS carried a 30-minute supply of oxygen.

The PLSS used on Apollo 9 through 14 weighed 61 kg (135 lb) and furnished the suited crewmen with four hours of primary life support, 30 minutes of emergency life support, communications, telemetry and controls and displays for the lunar exploration missions. Upgrades to the system for use on Apollo 15 through 17, when the Lunar Rover was available and thus allowed for longer EVAs, increased the duration to at least six hours of primary life support. On Dec. 12, 1972, the world’s record for the longest space walk (7 hours and 37 minutes) was set by Apollo 17 Astronauts Cernan and Schmitt using the Apollo PLSS.



Figure B.1-8. The Berkut EVA suit used by A. Leonov.

Voshkod. The first EVA suit was worn by Lt. Colonel Aleksey Leonov during the first EVA in 1965. This suit, the Berkut (“Golden Eagle”), was a modified Vostok Sokol-1 intravehicular suit. A white metal backpack provided 45 minutes of oxygen for breathing and cooling. Oxygen vented through a relief valve into space, carrying away heat, moisture, and exhaled carbon dioxide. Suit pressure could be set at either 40.6 kPa (5.88 psi) or 27.4 kPa (3.97 psi).

Salyut/Mir. The next evolution of the Soviet EVA suit was actually planned for use on the lunar surface. This Orlan (“Sea Eagle”) suit was never used for this purpose but the design was adapted for later use on EVAs from Soviet space stations.

The first variant of this suit, the Orlan-D, was used for an EVA at the Salyut 6 space station in December 1977. The Orlan-D was based on the Orlan lunar EVA suit, the most distinctive features of which were a hard torso, adjustable soft limbs, and simple self-donning via a hatch in the back. The hatch cover contained life support equipment, removing the need for external hoses. The Orlan lunar suit was designed to be used by one cosmonaut on a single mission. Orlan-D, as the redesigned suit was called, was to remain aboard a station for up to 2 years and be used by several cosmonauts. The suit operated at 40 kPa (5.8 psi), permitting a pure oxygen prebreathe period of only 30 minutes. For Salyut 6, EVA duration was limited to about 3 hours. A waist tether with a “snap lock” tether hook for attaching to handrails outside the station was considered integral to the suit. The Orlan-D relied for electrical power and voice communications on an umbilical plugged into a socket in the space station transfer compartment. A few improvements were incorporated into the Orlan-D that were flown on the Salyut 7 station based on Salyut 6 EVA experience. For example, external connectors were added to supply the cosmonauts with air and cooling water through an umbilical connected to the Salyut 7 life support system while they were in the transfer compartment airlock. This permitted them to avoid using their finite suit supplies until they were ready to venture outside. In addition, the suit controls were “more conveniently located on the chest,” there was an improved cooling system, and EVA duration was extended to 5 hours.



Figure B.1-9. The Orlan DM EVA suit. (Photo credit: Andy Salmon).

The next variant of this system was the Orlan-DM. This suit was designed for deployment on the *Mir* space station but was first tested on the Salyut 7 station in 1985. Orlan-DM featured several improvements over the Orlan-D, including bright lights at the temples of the “headset” for illuminating suit control dials; improved controls; sturdier construction, including rubberized fabric shoulder belts in place of the Orlan-D’s rubber belts; and greater mobility. The suits reached Salyut 7 aboard Cosmos 1669 (July 21, 1985), a prototype Progress freighter improved for *Mir*.

The third variant of this system was the Orlan-DMA, an upgrade of the short-lived model Orlan-DM (1985-1988). Like earlier Orlan models, Orlan-DMA retained the distinctive rear-entry hatch built into its hard aluminum alloy torso. A cable lanyard and locking handle were used to close and seal the rear hatch. Orlan-DMA’s life support system activated when the handle locked into place. Improvements included:

- Composite fabric in the arms and legs was lighter, more flexible, and tougher than previously used fabrics. Arms and legs could be removed for repair or replacement. The suit was sized for specific cosmonauts by pulling or releasing cables and

pulleys in the arms and legs.

- In the event of glove puncture, a forearm cuff inflated around the wrist using air from the backup oxygen tank, sealing off the cosmonaut's glove until he could return to the airlock; though painful, this was certified by volunteers in a vacuum chamber as a life-saving system.
- More durable life support system electrical motors.
- Improved gloves for better hand mobility. Gloves were custom-made for each cosmonaut (some sources, however, state that only two sizes were available).

The Orlan-DMA weighed 105 kg (231 lb) fully charged and 90 kg (198 lb) empty. The integral backpack measured 1.19 m (3.9 ft) long and 48 cm (18.9 in) wide. The suit had a maximum operating pressure of 40 kilopascal (5.8 psi) and a minimum pressure of 26.2 kPa (3.8 psi). Typical EVA duration was 6 to 7 hr, up from 5 hr for the Orlan-DM. Like the Orlan-D and Orlan-DM suits before it, Orlan-DMA had dual polyurethane rubber pressure bladders, one inside the other. The inner bladder inflated only if the primary layer was punctured. A replaceable lithium hydroxide cartridge absorbed exhaled carbon dioxide. Like earlier Orlan models, Orlan-DMA's liquid-cooling garment coverall had an integral head covering. Voice communication was by the Korona system, which included two microphones, two earphones, and primary and backup transceivers and amplifiers. Korona's antenna was embedded in the suit's outer fabric layer. Orlan-DMA's chief improvement was its add-on radio and battery package for making the suit autonomous. Both Orlan-D and Orlan-DM relied on an umbilical connection with the space station for their electricity and communications and to supply the ground with telemetry on cosmonaut and suit health. The add-on package was phased in during 1990 so that Orlan-DMA could be used with the SPK maneuvering unit, the Soviet equivalent of the U.S. MMU.

The final variant in this series is the Orlan-M, first used at the Mir space station in 1997. The Orlan-M constituted a modest upgrade of the Orlan-DMA. The most noticeable additions were a second visor on the top of the helmet (i.e., a "moon roof"), and bearings in the upper calf area of the legs. Its slightly higher (40.7 kPa; 5.9 psi) operating pressure was not a hindrance, nor did the crew report any increase in fatigue. Crews also reported that the new Orlan-M gloves were easier to use than the Orlan-DMA gloves.



Figure B.1-10. The SPK maneuvering unit, designed for use with the Orlan-DMA suit.

EVA Tools. In the planning phase of each mission, tools are selected based on the jobs that must be done. Specialized tools are often created when no existing tool will do the job. Many of the tools found in a traditional toolbox on Earth are used in space as well (see Figure B.1-11). Thus a large number of unique tools exists and are available for EVA use, but this section will not provide an exhaustive description of this tool set. A useful description of tools used for Apollo missions can be found in Alton (1989). Similarly, a description of tools used in a microgravity environment can be found in Trevino and Fullerton (1997). However, there are some common modifications and characteristics used to make these tools easier and safer to use.

As Apollo spacesuits were being developed for walking on the surface of the Moon, a special set of tools was designed to assist astronauts in their sample-collecting task. The Apollo suits were stiff, and bending at the waist was difficult and awkward. Creating long-handled sampling tools such as scoops and rakes solved the problem of picking up rocks and soil samples. Because pressurized spacesuit gloves made grasping difficult, tool handles were made thicker than normal.

Several criteria are used in creating useful tools for EVAs in a microgravity environment. As with the Apollo missions, tools have to be easily gripped by astronauts wearing pressurized gloves. The tools have to be safe to use and reliable under temperatures that can vary by hundreds of degrees. Tools also need some sort of attachment system so that if an astronaut should "drop" them, the tools will not float away. To keep control of tools, each tool has some sort of tether or locking system. A socket wrench has a key that has to be inserted into a holder before a socket can be installed at the end of the wrench. Once the key is removed, the socket is then locked onto the wrench and cannot be removed without use of the key again. A short tether and clip enables the astronaut to hang on to the wrench in case it is dropped. There is even a tether on the key.

To the degree that future EVA suits and gloves have these same constraints, similar functionality will be required in tools. As suits and gloves are improved, tools will take on more of the characteristics of those used by unsuited people. However, some characteristics, such as the use of tethers (or similar securing devices) will continue to be incorporated into EVA tools.

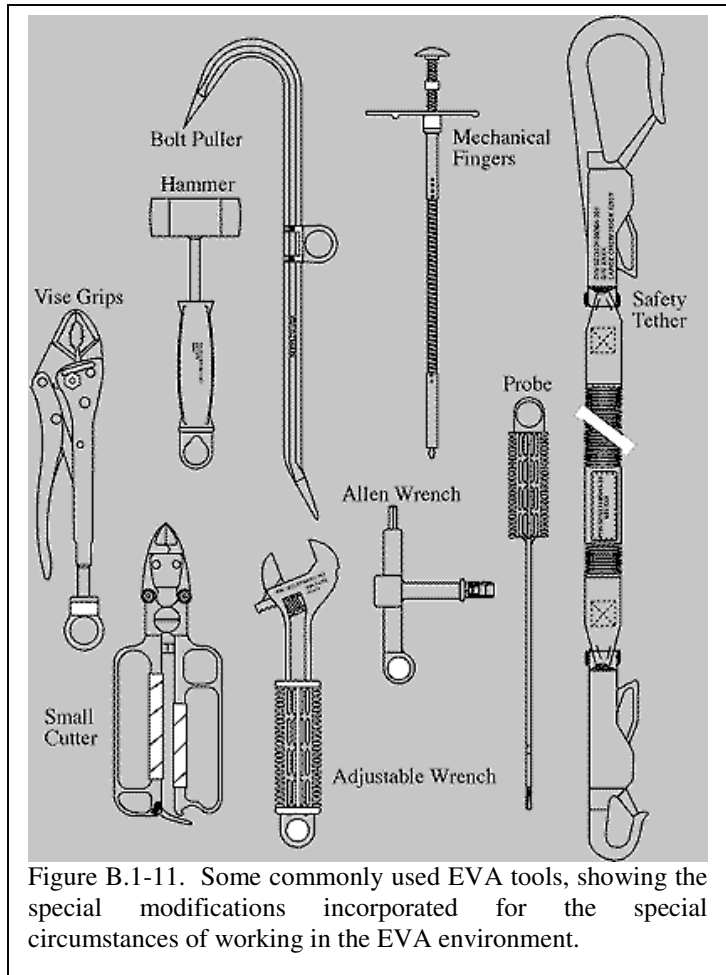

Figure B.1-11. Some commonly used EVA tools, showing the special modifications incorporated for the special circumstances of working in the EVA environment.

B.2 Teleoperated Robotic Devices

Of the elements currently carried under the Human Operated Internal Work System element EVA Functional Breakdown (Element 1.2 as indicated in Figure 1.3-1) only the Teleoperated Robotic Devices have a significant historical record for operational systems. This section will describe the history of this category of systems for the one significant system in this category that has been developed and operated in space: the Shuttle RMS.

Shuttle Remote Manipulator System. The RMS, also known as the Canadarm, is the mechanical arm portion of the Shuttle Payload Deployment and Retrieval System. This system has been in operational use since 1981 when the RMS first flew aboard the Space Shuttle Columbia. The arm maneuvers a payload from the payload bay to its deployment position, and then releases it. The RMS can also grapple a free-flying payload, maneuver it to the payload bay, and then berth it in the Orbiter. These payloads can have a mass up to 29,500 kg (65,000 lb).

The RMS has also proven to be a highly useful system for conducting EVA operations—serving as a mobile extension ladder for EVA crewmembers for work stations or foot restraints, maneuvering orbital replacement unit (ORU)-type payloads as part of EVA assembly, servicing or maintenance tasks, and be used as an inspection aid to allow the flight crewmembers to view the Orbiter or payload surfaces through one or two television cameras on the RMS.

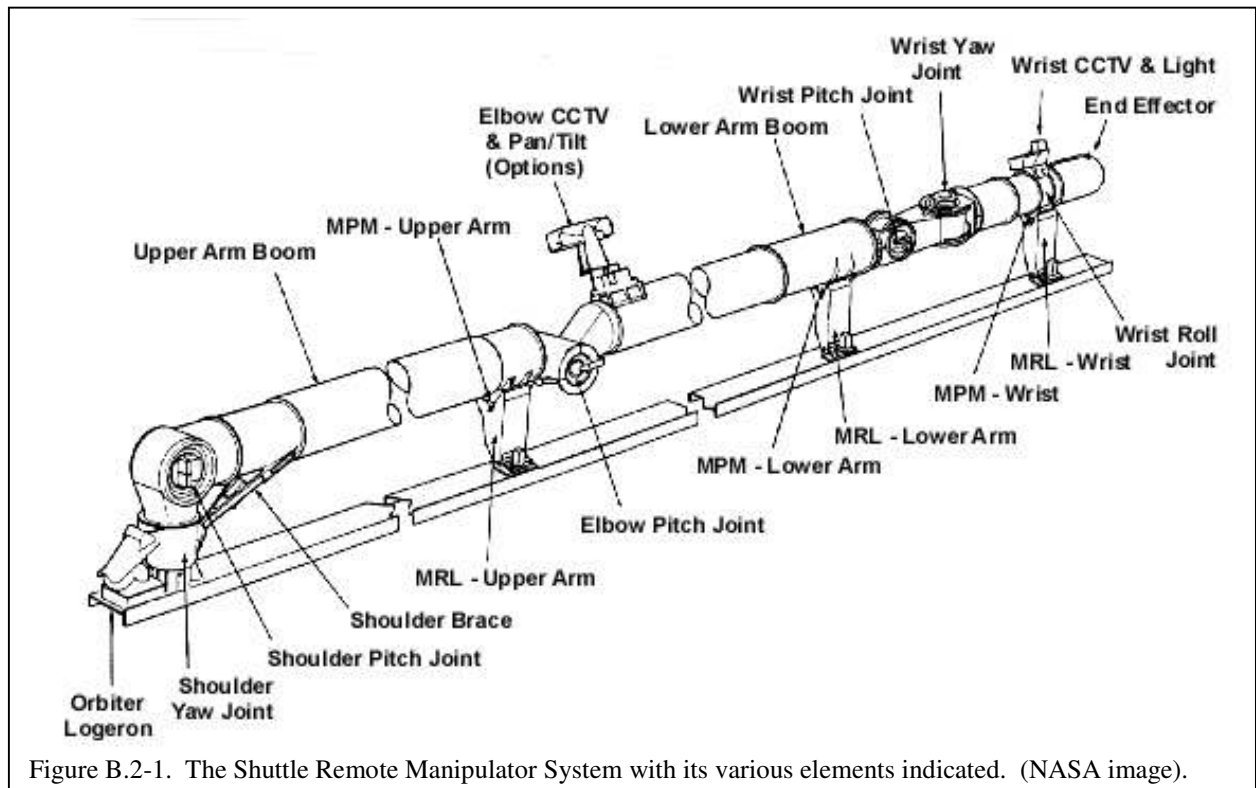

(Adapted from <http://www.shuttlepresskit.com/scom/scom.pdf>, accessed on April 21, 2003, and from <http://prime.jsc.nasa.gov/ROV/rms.html>, accessed on April 21, 2003.)

The RMS arm is 15.3 m (50 ft 3 in.) long and 0.38 m (15 in.) in diameter. The arm has 6 degrees of freedom: three translational (X, Y, and Z) and three rotational (P, Y, and R). They are in reference not only to the Orbiter, but also to the end effector and to payloads. The arm consists of six joints connected via structural members and has a payload capturing device (the end effector) on the end. The arm has a mass of 411 kg (905 lb), and the total system has a mass of 452 kg (994 lb).

The basic RMS configuration consists of a manipulator arm; an RMS display and control panel, including rotational and translational hand controllers at the Orbiter aft flight deck flight crew station; and a manipulator controller interface unit that interfaces with the Orbiter computer. The major components of the arm are depicted in Figure B.2-1.

One flight crewmember operates the RMS from the aft flight deck control station, and a second flight crewmember usually assists with television camera operations. This allows the RMS operator to view RMS operations through the aft flight deck payload and overhead windows and through the closed-circuit television monitors at the aft flight deck station.

B.3 Transportation

This section provides a brief discussion of transportation systems used on U.S. space missions, both free space and on planetary surfaces. The discussion covers the Manned Maneuvering Unit and its predecessors (used in free space) and the Apollo Lunar Rover Vehicle, thus far the only system designed to transport humans on another planetary surface.

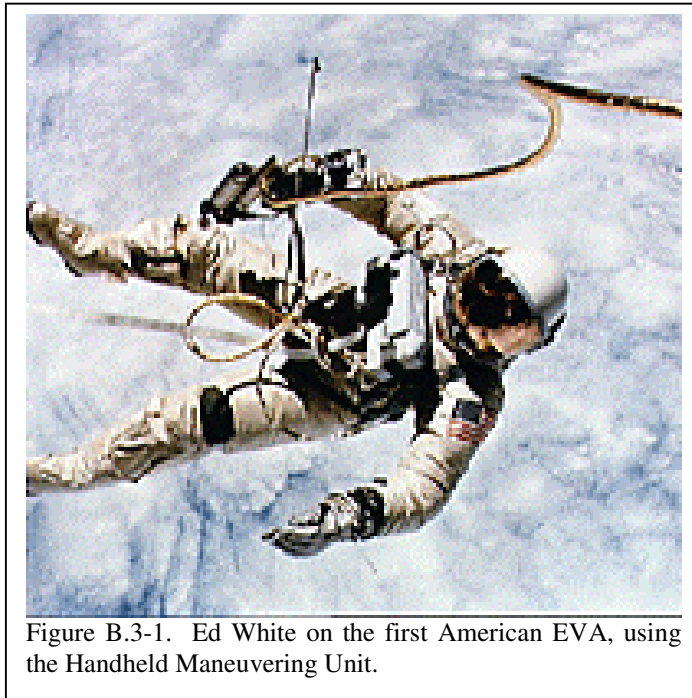

Figure B.3-1. Ed White on the first American EVA, using the Handheld Maneuvering Unit.

Handheld Maneuvering Unit. During the first American EVA (June 3, 1965, conducted on the Gemini 4 mission), Edward White experimented with a personal propulsion device, the Handheld Maneuvering Unit (HHMU; also referred to as the Handheld Self Maneuvering Unit, HHSMU). In addition to White's use, this device was also used on four subsequent EVAs: Cernan (Gemini 9A), Collins (Gemini 10), Gordon (Gemini 11) and Aldrin (Gemini 12).

The HHMU tested by White was a three-jet maneuvering gun (see Figure B.3-1). Two jets were located at the ends of rods and aimed back so that firing them pulled White forward. A third jet was aimed forward to provide a braking force. By holding the gun near his center of mass

and aiming it in the direction in which he wanted to travel, he was able to propel himself forward. Stopping that movement required firing the center jet. The propulsive force of the HHMU was produced by releasing compressed nitrogen from two small built-in tanks.

Although the HHMU worked as intended, it had two disadvantages. To produce the desired motion, it had to be held as close to the astronaut's center of mass as possible. Determining the center position was difficult because of the bulky space suit that White wore and was a matter of guesswork and experience. Furthermore, precise motions to position an astronaut properly during an activity such as servicing a satellite were difficult to achieve and maintain and proved physically exhausting.

(Adapted from <http://quest.arc.nasa.gov/space/teachers/suited/6work.html>; accessed on January 23, 2003.)

Astronaut Maneuvering Unit. The next evolution in transportation for free space was to increase the astronaut's duration and maneuverability while on an EVA. To free both of the astronaut's hands and to provide for the increased mass and volume of a larger propellant supply, this device was configured to be worn as a backpack. This structure also served as the mounting location for a larger number (compared to the HHMU) of exhaust nozzles. This concept got its start in the Air Force (referred to as the EMU, not to be confused with the Space Shuttle suit that uses the same name and acronym) that intended to use it for its Manned Orbiting Laboratory space station in the late 1960s. While the Manned Orbiting Laboratory was never built, the EMU, (built by the Vought Corporation) was considered promising. A tethered version of it called the Astronaut Maneuvering Unit (AMU) was carried aboard Gemini 8 and Gemini 9 for tests (see Figure B.3-2). This system had about 15 times more propellant than the HHMU and used Freon instead of nitrogen as propellant, further multiplying the system's total impulse. How oxygen acted in vacuum was fairly well known, but David Scott (Gemini 8) worried about how Freon would behave. One problem soon showed up: at low temperatures, the Freon caused the system's poppet valve to stick open when triggered, and the escaping gas threatened to tumble the astronaut in space. New seals solved the problem and two new shutoff valves added a safety factor.



Figure B.3-2 AMU as configured for Gemini 9. (NASA photo S66-33167).

Ultimately, this system was never used in space. The flight of Gemini 8 was terminated early due to a thruster failure on the Gemini spacecraft (David Scott would have tested the unit) and the Gemini 9 EVA was terminated early before Eugene Cernan was able to don the AMU for test.

However, the development and testing of the Gemini AMU did lead to the development and flight of a free-flying system on Skylab. Referred to as the M509 Astronaut Maneuvering Unit, it was flown only inside the space station. However, the experiment confirmed that a maneuvering device of that design was both feasible and desirable for future EVA use. Five of the six astronauts who flew in the M509 accumulated a total of 14 hours testing the advanced device.

Built into the M509 frame was a replaceable tank of compressed nitrogen gas. Controls for the unit were placed at the ends of "arm rests." To move, the astronaut worked rotational and translational hand controls. Propulsive jets of nitrogen gas were released from various nozzles spaced around the unit. The 14 nozzles were arranged to aim top-bottom, front-back, and right-

left to produce six degrees of freedom in movement (i.e., forward and back, up and down, and side to side, and roll, pitch, and yaw). With 11 additional nozzles, precise positioning with the M509 was far simpler than with the HHMU of the Gemini program. The astronaut was surrounded by the unit, taking the guesswork out of determining center of mass and making control much more accurate. The astronaut could move closely along the surface of a curved or irregularly shaped object without making contact with it.



Figure B.3-3. A Skylab 3 onboard photo shows astronaut Jack Lousma as he flew the M509 AMU in the forward dome of Skylab while in Earth orbit.

Manned Maneuvering Unit. The AMU and M509 led to the MMU for use during early Space Shuttle flights. The MMU was designed to operate in the microgravity environment of outer space and under the temperature extremes found there. The MMU was operated by a single space-suited astronaut. The unit featured redundancy to protect against failure of individual systems. It was designed to fit over the life-support system backpack of the Shuttle EMU.

The MMU was approximately 127 cm high, 83 cm wide, and 69 cm deep. When carried into space by the Shuttle, it was stowed in a support station attached to the wall of the payload bay near the airlock hatch. Two

MMUs were carried on a mission with the second unit mounted across from the first on the opposite payload bay wall. The MMU controller arms were folded for storage, but when an astronaut backed into the unit and snapped the life-support system into place, the arms were unfolded. Fully extended, the arms increased the depth of the MMU to 122 cm. To adapt to astronauts with different arm lengths, controller arms could be adjusted over a range of approximately 13 cm. The MMU was small enough to be maneuvered with ease around and within complex structures. With a full propellant load, its mass was 148 kg.

Gaseous nitrogen was used as the propellant for the MMU. Two aluminum tanks with Kevlar® filament overwrappings contained 5.9 kg of nitrogen each at a pressure of 20.68 kilopascals, enough propellant for a six-hour EVA, depending on the amount of maneuvering done. In normal operation, each tank fed one system of thrusters. At the direction of the astronaut, through manual control or through an automatic attitude-hold system, propellant gas moved through feed lines to varying combinations of 24 nozzles arranged in



Figure B.3-4. Astronaut Bruce McCandless makes the first untethered free flight using the MMU.

clusters of three each on the eight corners of the MMU. The nozzles were aimed along three axes perpendicular to each other and permit six degrees of freedom of movement. To operate the propulsion system, the astronaut used his or her fingertips to manipulate hand controllers at the ends of the MMU's two arms. The right-hand controller produced rotational acceleration for roll, pitch, and yaw. The left controller produced acceleration without rotation for moving forward-back, up-down, and left-right. Coordination of the two controllers produced intricate movements in the unit. Once a desired orientation had been achieved, the astronaut could engage an automatic attitude-hold function that maintained the inertial attitude of the unit in flight. This freed both hands for work.



Figure B.3-5. The Apollo 14 astronauts used this prototype of the MET during their geological and lunar surface simulation training in the Pinacate volcanic area of northwestern Sonora, Mexico. (NASA photo S70-29505).

The MMU was used on three Shuttle missions in the mid 1980s. It was first tested by Bruce McCandless and Robert Stewart on the 1984 STS 41-B mission (see Figure B.3-4). Taking turns, the two astronauts flew the MMU out from the Orbiter's payload bay to a distance of about 100 m and tested complex maneuvers. On STS-41C, the next Shuttle mission, James Van Hoften and George Nelson used the MMU to capture the Solar Maximum mission satellite and bring it into the Orbiter's payload bay for repairs and servicing. Their work increased the life span of the satellite. The final MMU mission was STS-51A that flew in November of 1984. The propulsion unit was used to retrieve two communication satellites that did not reach their proper orbit because of faulty propulsion modules. Joseph Allen and Dale Gardner captured the two satellites and brought them into the Orbiter payload bay for stowage and return to Earth.

(The previous section was adapted from <http://quest.arc.nasa.gov/space/teachers/suited/6work.html>; accessed on Jan 23, 2003.)

Modularized Equipment Transporter. The Modular Equipment Transporter (MET) was a two-wheeled vehicle that was used to carry instruments, geological tools, and photographic equipment—three cameras, two sample container bags, a Special Environmental Sample Container, spare film magazines, and a Lunar Surface Penetrometer. Nicknamed the "Rickshaw" because of its shape and method of propulsion, its only use was on Apollo 14.

The MET's mass was 13.6 kg and it was capable of carrying up to 160 kg, but its actual load was much lighter. It used two pneumatic tires for mobility. The low temperature limit (-56°C) to which the tires were designed required the use of a special synthetic rubber for both the tires and tubes. In addition to carrying tools and equipment, the crew found that it also served well as a mobile workbench.

Because constant gripping of the handle against suit pressure would have tired the hand and arm of the crewmen, the handle was designed to permit control of the MET without requiring constant gripping. A triangular shape was used. The base of the triangle was long enough for insertion of the hand but the dimension perpendicular to the base was shorter than the width of

the hand. Rotation of the hand toward the shorter dimension applied sufficient pressure for pulling and rotational control.

During the Apollo 14 mission, the tires inflated as expected, and the MET was loaded with equipment without difficulty. The crew reported that it performed very satisfactorily. It was more stable than had been expected and could traverse the surface over a range of speeds without loss of control. The tires were smooth and did not kick up much dust. No appreciable soil adhesion was noticed on the tires or other structural components. The only difficulty encountered in pulling the MET was while attempting to climb relatively steep grades. Near Cone Crater it was easier for both astronauts to carry the MET than for one of them to pull it uphill alone. As it rolled on a level surface or downhill at relatively high speeds, the MET bounced; however, bouncing on the Moon was less than that observed on Earth in lunar-g simulations.

(The previous section was adapted from http://www.lpi.usra.edu/expmoon/Apollo14/A14_Overview_spacecraft.html; <http://www.hq.nasa.gov/office/pao/History/SP-4214/ch12-3.html>; <http://ares.jsc.nasa.gov/HumanExplore/Exploration/EXLibrary/docs/ApolloCat/Part1/Misc.htm>; accessed on Jan 23, 2003.)

Lunar Rover Vehicle. The LRV transported two astronauts on exploration traverses on the Moon during the Apollo 15, 16, and 17 missions. The LRV carried tools, scientific equipment, communications gear, and lunar samples.

The LRV was the first manned surface transportation system designed to operate on the Moon. It marked the beginning of a new technology and represented an experiment to overcome many new and challenging problems for which there was no precedent in terrestrial vehicle design and operations.

The Boeing Co., Aerospace Group built the LRV at its Kent Space Center near Seattle, Washington, under contract to the NASA-Marshall Space Flight Center. Boeing's major subcontractor was the Delco Electronics Division of the General Motors Corp. Three flight vehicles were built, plus seven test and training units, spare components, and related equipment.

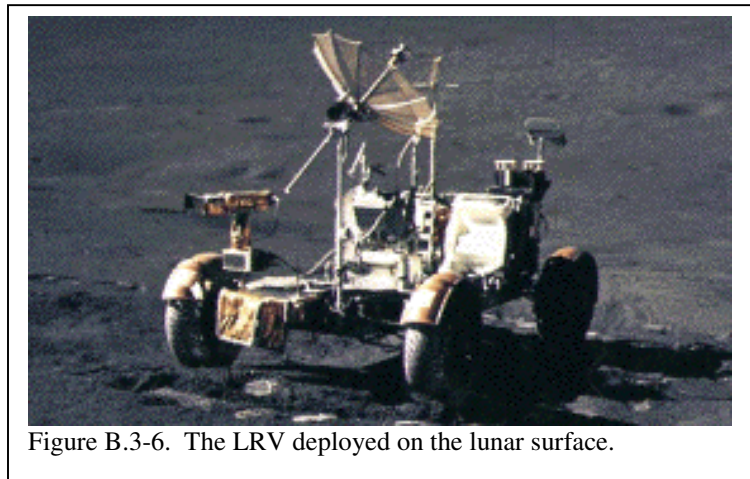

Figure B.3-6. The LRV deployed on the lunar surface.

The LRV was 310 cm (10 ft, 2 in.) long; had a 183 cm (6-ft) tread width; was 114 cm (44.8 in.) high; and had a 229 cm (7.5-ft) wheelbase. Each wheel was individually powered by a quarter-horsepower electric motor (providing a total of 1 horsepower) and the vehicle's top speed was about 13 km/hr (8 mph) on a relatively smooth surface.

Two 36-volt batteries provided the vehicle's power, although either battery could power all vehicle systems if required. The front and rear wheels had separate steering systems, but if one

steering system failed, it could have been disconnected and the vehicle would have operated with the other system (this actually occurred on Apollo 15 when the front system failed). Either astronaut could operate the LRV.

A communication system relayed voice and data from the astronauts' suit to Earth and allowed mission control to talk directly to the astronauts. In addition, a remotely controlled camera allowed mission control to visually monitor the activities of the astronauts.

Weighing approximately 209 kg (460 lb Earth weight) when deployed on the Moon, the LRV carried a total payload weight of about 490 kg (1,080 lb). This cargo included astronauts and their portable life support systems (about 363 kg (800 lb)), 45 kg (100 lb) of communications equipment, 54 kg (120 lb) of scientific equipment and photographic gear, and 27 kg (60 lb) of lunar samples.

The LRV was designed to operate for 78 hours during the lunar day. It could make several exploration sorties up to a cumulative distance of 65 km (40 miles). Because of limitations in the astronauts' PLSS, however the vehicle's range was restricted to a radius of about 9.5 km (six miles) from the lunar module (LM). This provided a walk-back capability to the LM should the LRV become immobile at the maximum radius from the LM.

(Adapted from NASA Press Kit, Release No: 71-119, Project: Apollo 15.)

B.4 Airlocks

Airlocks have been developed and used operationally by both the Russian (Soviet Union) and U.S. space programs. This section discusses airlocks used for Russian missions, U.S. missions and for the joint Apollo/Soyuz mission. Although carried as part of the Transportation System element of the EVA Functional Breakdown (Element 1.3 as indicated in Figure 3.1-2), it has been broken out as a separate section for purposes of this report.

Voshkod. The first airlock used in space was developed by the Soviet Union for the Voshkod spacecraft. The Voskhod itself was an adaptation of the single place Vostok spacecraft, modified to carry either three crew (the 3KV version) or two crew with the airlock (the 3KD version).

The airlock (see Figure B.4-1), named Volga, used on the Voskhod 3KD spacecraft was inflatable. A flexible cylinder connected two rigid end caps, each end cap containing an airlock door. Prior to deployment, it measured 700 mm in diameter and 770 mm thick. When inflated it measured 2.5 m long,



Figure B.4-1. The Voskhod spacecraft (minus the service module) with the inflatable airlock deployed. Note head and shoulders of a suited crewmember at the top of the airlock. (Photo courtesy R. Fullerton)

with an internal diameter of 1.0 m and external diameter of 1.2 m. The inward-opening airlock hatch was 65 cm (26 in) wide. The total mass of the Volga airlock was 250 kg.

This airlock system was used only once during an operational mission. Lt. Colonel Aleksey Leonov used the airlock as part of the first space walk during Voskhod 2 mission. Leonov conducted a 10-minute EVA tethered to the Voskhod. The EVA almost ended in disaster when the stiffness of his inflated spacesuit prevented him from reentering the airlock. He had to bleed air from the suit in order to get back

into the airlock. However, his problems were not over. After Leonov managed to get back into the Voskhod cabin, the primary hatch would not initially seal completely. While attempting to properly seal this hatch, the life support system compensated by flooding the cabin with oxygen, creating a serious fire hazard in a craft only qualified for sea level nitrogen-oxygen gas mixes. The hatch was eventually resealed and Leonov and Colonel Pavel Belyayev returned to Earth the next day. Follow-on Voskhod missions were cancelled as too dangerous.

Salyut. The history of Russian space stations is one of gradual development marked by upgrades of existing equipment, reapplication to new goals of hardware designed for other purposes, rapid recovery from failures, and constant experimentation. The earliest Salyut stations were single modules, designed for only temporary operations. The Soviet Union launched and operated five of these first generation stations beginning in 1971, none of which was outfitted with an airlock module and thus were not capable of conducting an EVA.

Beginning with the launch of Salyut 6 in 1977 the Soviet space station program evolved from short-duration to long-duration stays. Like the first-generation stations, Salyut 6 and the nearly identical Salyut 7 were launched unmanned and their crews arrived later in Soyuz spacecraft. In addition to the incorporation of a second docking port (added to allow Progress resupply vehicles to dock with the station while a Soyuz vehicle was also at the station), these two stations were equipped with an airlock, allowing the crews to conduct EVAs. The 2-m-diameter (6.56-ft-diameter) cylindrical compartment included a round hatch leading out onto the station's port side. An airtight hatch at the front separated the compartment from the docked Soyuz, while another at the rear sealed off the 4.15-m-diameter (13.6-ft-diameter) cylindrical work compartment. The transfer compartment contained valves to vent its air into space; valves to refill it with air from the work compartment; control and display panels; connectors for umbilicals providing electricity and communications to the suits; anchoring points for restraints and tethers; and storage compartments for tethers, foot restraints, two Orlan-D suits, and other EVA equipment. Minor improvements based on Salyut 6 experience were incorporated into the Salyut 7 systems. For example, external connectors were added to supply the cosmonauts with

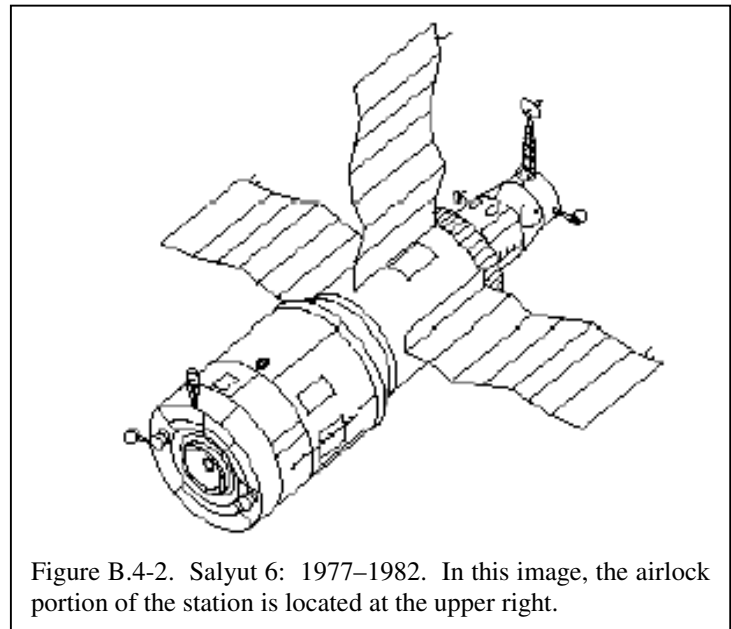

Figure B.4-2. Salyut 6: 1977–1982. In this image, the airlock portion of the station is located at the upper right.

air and cooling water through an umbilical connected to the Salyut 7 life support system while they were in the transfer compartment airlock.

(Adapted from <http://spaceflight.nasa.gov/spaceneeds/factsheets/pdfs/russian.pdf>; accessed on Feb 6, 2003 and from *Walking to Olympus*, Portree and Trevino [1997].)

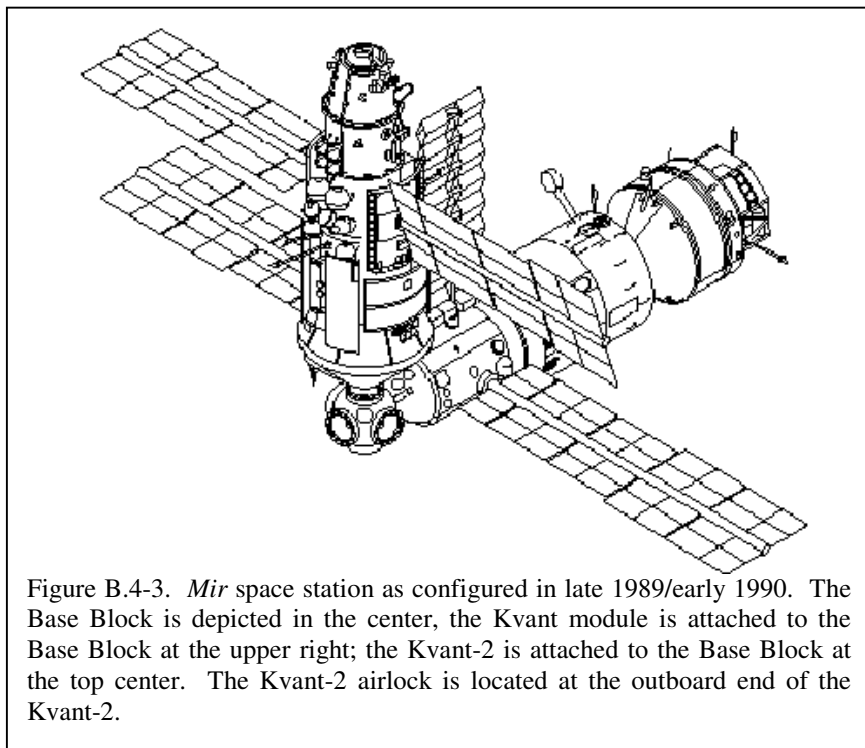

Figure B.4-3. *Mir* space station as configured in late 1989/early 1990. The Base Block is depicted in the center, the Kvant module is attached to the Base Block at the upper right; the Kvant-2 is attached to the Base Block at the top center. The Kvant-2 airlock is located at the outboard end of the Kvant-2.

Mir. The next evolution of the Soviet space station and associated airlock system was the *Mir* station, launched in 1986. The *Mir* core module resembles Salyuts 6 and 7, but has six docking ports instead of two. The two fore and aft ports are used primarily for docking crewed and uncrewed vehicles. The four radial ports in a node at the station's front are for berthing large modules. One of these modules, Kvant-2, was equipped with a dedicated airlock for EVA use. The Kvant-2 was subdivided into three

sections isolated from each other by hatches. The most outboard section was the airlock featuring a 1-m-diameter hatch, opening outward. A special backpack unit, the *Sredstvo Peredvizheniy Kosmonavtov* ("Cosmonaut Maneuvering Equipment") (SPK), an equivalent of U.S. MMU, was located inside Kvant-2 airlock. It was expected to be used during EVAs, particularly during Buran missions to *Mir*.

The first *Mir* EVA—only the 19th of the Soviet space program—was a contingency EVA to permit Kvant, the station's first expansion module, to complete docking. It achieved soft dock, but full retraction of the Kvant probe proved impossible, and the docking collars remained separated by a few centimeters. A contingency EVA was quickly authorized. The *Mir* crew, Yuri Romanenko and Alexander Laveikin, left one of the four berthing ports in the forward transfer compartment and moved along *Mir*'s hull to the aft port. They discovered an "extraneous white object" jammed between the two spacecraft. With difficulty Laveikin freed and discarded the object. The cosmonauts waited nearby while the TsUP commanded the Kvant probe to retract, completing hard dock, then returned inside an expanded *Mir* station.

The forward transfer compartment of the core module continued to be used as an airlock until the arrival of the Kvant-2 module in 1989. With its inaugural use in January of 1990, the Kvant-2 airlock became the primary means of EVA ingress/egress for *Mir* EVAs.

(Adapted from <http://spaceflight.nasa.gov/spaceneews/factsheets/pdfs/russian.pdf>; accessed on Feb 6, 2003, and from *Walking to Olympus*, Portree and Trevino [1997].)

Buran. The Soviet Union also built and launched (unmanned) a reusable shuttle much like the U.S. Space Shuttle. One of the missions of this shuttle, named Buran, was to have been servicing missions to *Mir*. This required a docking capability, which took the form of an airlock located in the payload bay immediately aft of the crew compartment; see Figure B.4-4. A closer view of this airlock is shown in Figure B.4-5. In addition to its docking function, the airlock could also be used for EVAs. The Buran was flown only once before funding problems caused this vehicle to be mothballed. This single flight was for test purposes only, which did not include a human crew or docking to *Mir*. Thus this airlock system was never used operationally.

Apollo-Soyuz Test Project. The Apollo-Soyuz Test Project was the first international human spaceflight, taking place July 15-24, 1975, at the height of the détente between the United States and the Soviet Union. This mission was specifically designed to test the compatibility of rendezvous and docking systems for American and Soviet spacecraft, and to open the way for international space rescue as well as future joint missions.



Figure B.4-4. A model of the Buran space shuttle. The airlock is located at the upper end of the payload bay.

To carry out this mission, existing American Apollo and Soviet Soyuz spacecraft were used. A universal docking module was designed and constructed for NASA (by Rockwell International) to serve as an airlock and transfer corridor between the two craft. This module was 3.15 m long,



Figure B.4-5. Buran airlock. (Photo courtesy: R. Fullerton)

approximately 1.5 m maximum diameter, and had a mass of 2012 kg. Figure B.4-6 illustrates a cutaway view of the module and identifies major subsystems. Differences in atmospheric pressures and gas mixtures used by each spacecraft (100 percent oxygen at 0.34 atmospheres in the Apollo Command Module and a sea level oxygen/nitrogen mixture at 1.0 atmospheres for the Soyuz) meant that direct travel between the two spacecraft was not possible; the crew were required to spend a certain amount of time in the docking module to acclimate before transferring from one vehicle to the other. The Apollo vehicle

supplied all power for the docking module. There was also no provision for carbon dioxide removal in the airlock; this function was accomplished by the life support system in both the Soyuz and the Apollo Command Module when the hatch to either vehicle was opened.

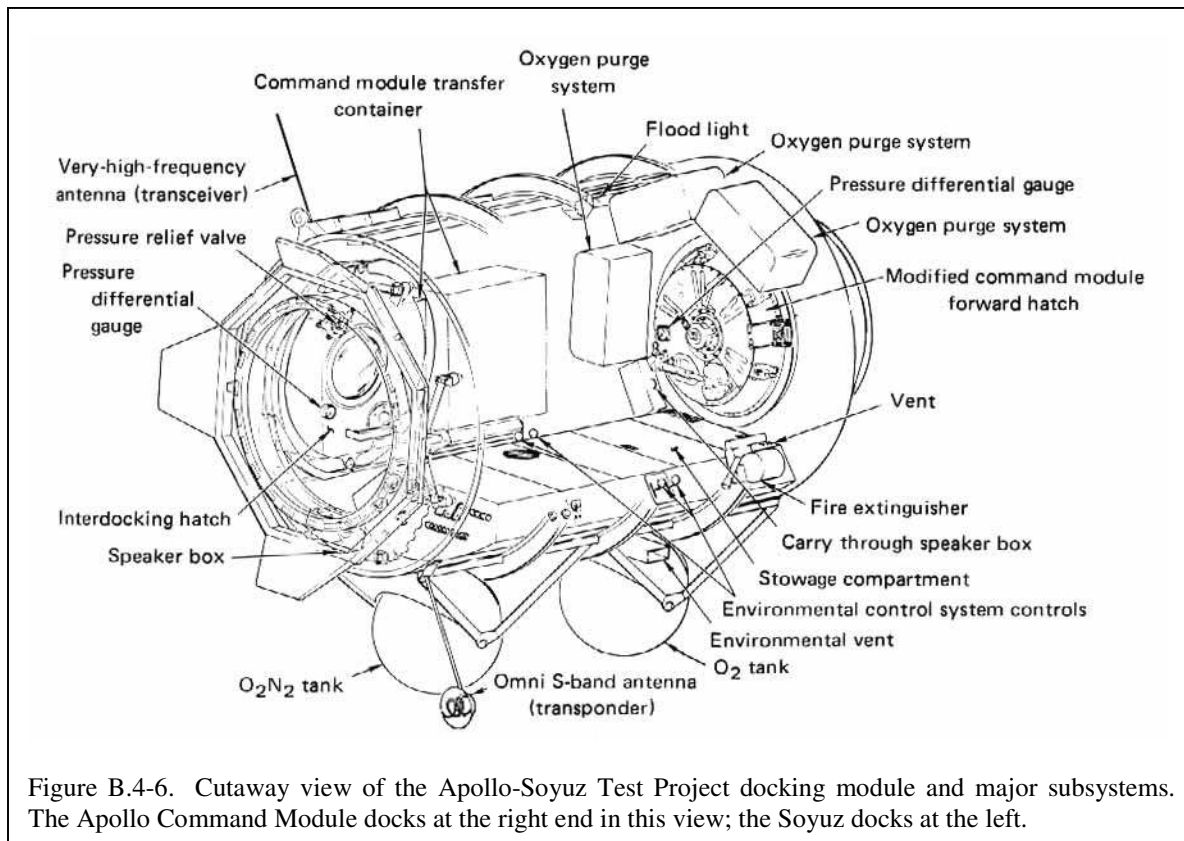

(Adapted from <http://history.nasa.gov/Timeline/100flt.html>; accessed on Feb 6, 2003.)

Skylab. The Skylab Airlock Module, as a connecting link between the Orbital Workshop and Multiple Docking Adapter, served a threefold purpose. Not only was it a major structural element of the Skylab cluster, but it served as a module containing the port through which an astronaut could leave the interior of Skylab in order to perform EVAs; and as the electrical, environmental, and communications control center for Skylab. In addition, many of the high-pressure containers for oxygen and nitrogen that provided Skylab's atmosphere were mounted on the trusses between the inner and outer walls of the Airlock Module.

The Airlock Module consists of two concentric cylinders. Matching the Orbital Workshop in diameter, the outer cylinder or Fixed Airlock Shroud carries the Payload Shroud during the launch, and it serves as mounting base for the structure that supports the Apollo Telescope Mount. The inner cylinder, or tunnel, represents the airlock. It forms the passageway through which crewmembers can move between the Workshop and the Multiple Docking Adapter. Hatches at both ends of the tunnel can be closed for depressurization, and a third hatch (based on the Gemini spacecraft hatch design) in the sidewall can be opened for the egress of a crewmember. After return of the crewmember, the egress hatch is closed, the tunnel is pressurized, and the forward and rear hatches are reopened.

The Airlock Module also contains the automatic Skylab malfunction alarm system, and the manual controls for Skylab pressurization and air purification, and for electric power and communications. Many of the supplies, and most of the control systems for Skylab are located in the Airlock Module; this module functioned as the "utility center" of the Skylab cluster.

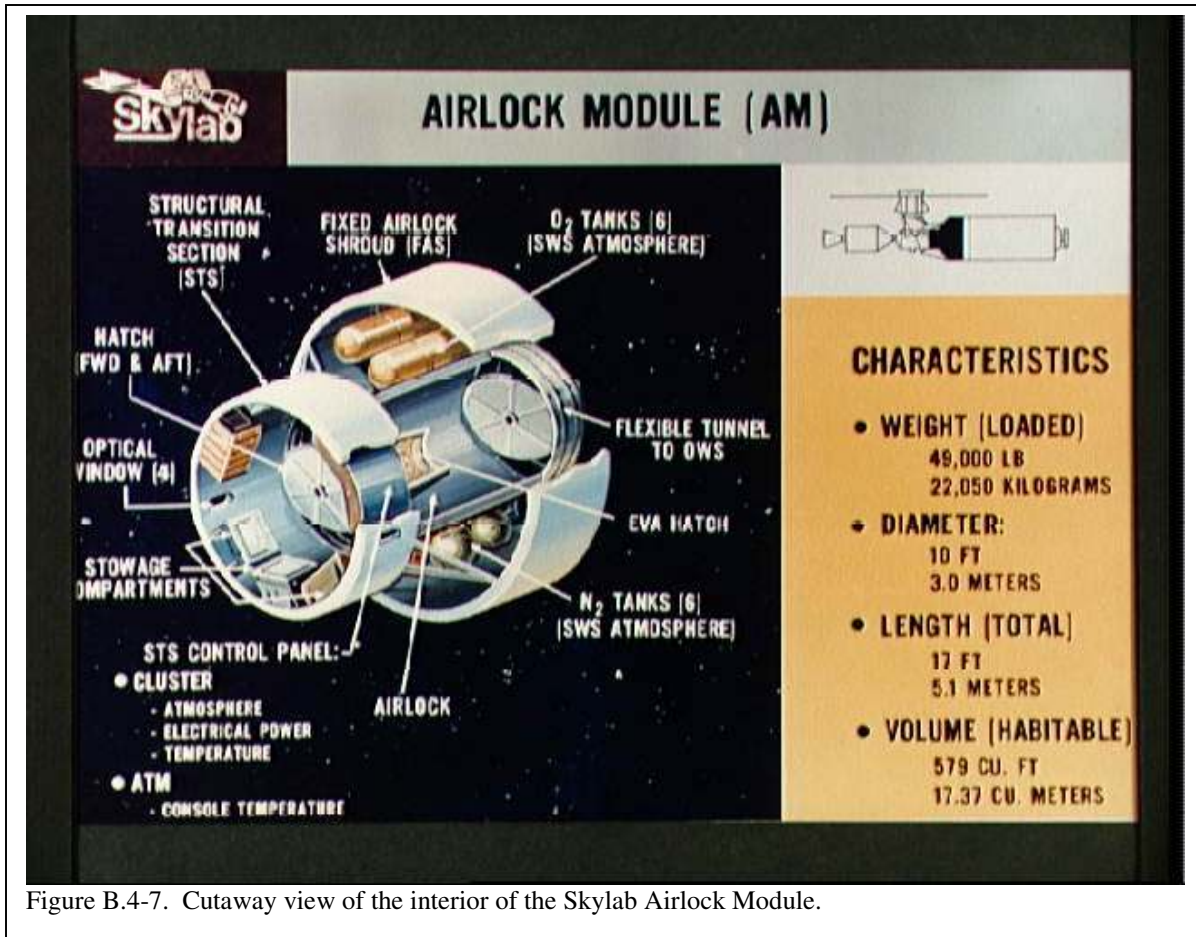

Figure B.4-7. Cutaway view of the interior of the Skylab Airlock Module.

Space Shuttle. The Space Shuttle airlock is sized to accommodate two EVA suited flight crewmembers simultaneously. Support functions include airlock depressurization and repressurization, EVA equipment recharge, liquid-cooled garment water cooling, EVA equipment checkout, donning, and communications. The EVA gear, checkout panel and recharge stations are located on the internal walls of the airlock. The airlock was originally located inside the middeck of the Orbiter's pressurized crew compartment but has been relocated to an external (payload bay) location to support Phase I (Shuttle-Mir program) and ISS missions (see Figure B.4-8 and B.4-9). When installed in the payload bay, insulation is installed on the airlock's exterior for protection from the extreme temperatures of space.

The Shuttle Airlock has an inside diameter of 160 cm (63 in.), is 210 cm (83 in.) long and has an internal volume of 150 ft³. The Airlock weighs 375 kg (825 lb) total, when empty. Each hatch weighs 33 kg (72 lb). When configured for installation inside the Orbiter crew

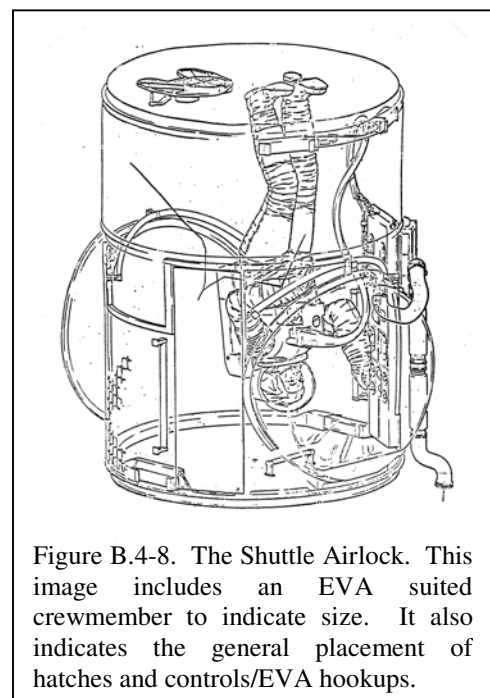

Figure B.4-8. The Shuttle Airlock. This image includes an EVA suited crewmember to indicate size. It also indicates the general placement of hatches and controls/EVA hookups.



Figure B.4-9. Space Shuttle *Endeavour* docked to the ISS during the STS-113 mission. (NASA image STS113-308-002)

compartment, it has two pressure-sealing hatches and a complement of airlock support systems. When configured for installation in the payload bay, two alternate configurations have been used. In one of these configurations an adapter tunnel connects the airlock to the Orbiter crew compartment (see Figure B.4-8). Two additional pressure-sealing hatches are installed, one at the “top” of the airlock and the other in the tunnel/adapter. This latter hatch is used for contingency EVA ingress/egress. For the other payload bay installation, no adapter tunnel is connected and ingress/egress for contingency EVAs use the same hatch as nominal operations. An additional hatch is installed in the “top” for use when the Orbiter is docked to the ISS (see Figure B.4-9). All hatches are the same diameter.

Airlock repressurization is controllable from the Orbiter crew cabin middeck and from inside the airlock. It is performed by equalizing the airlock's and cabin's pressure with equalization valves mounted on the inner hatch. The airlock is depressurized from inside the airlock by venting the airlock's pressure overboard. The two D-

shaped airlock hatches open toward the primary pressure source, the Orbiter crew cabin, to achieve pressure-assist sealing when closed.

Each airlock hatch has dual pressure seals to maintain pressure integrity. One seal is mounted on the airlock hatch and the other on the airlock structure. A leak check quick disconnect is installed between the hatch and the airlock pressure seals to verify hatch pressure integrity before flight.

The gearbox with latch mechanisms on each hatch allows the flight crew to open and close the hatch during transfers and EVA operations. The gearbox and the latches are mounted on the low-pressure side of each hatch; with a gearbox handle installed on both sides to permit operation from either side of the hatch.

To assist the crewmember before and after EVA operations, the airlock incorporates handrails and foot restraints. Handrails are located alongside the avionics and environmental control and life support system panels. Foot restraints are installed on the airlock floor nearer the payload bay side.

B.5 Support Systems

In order for any of the systems discussed above to be successfully fielded and operated requires certain support facilities. These support facilities can be broken into two general categories: those used to develop and tests systems, with subsequent training of personnel that will use them, and those facilities used to support these systems after they are deployed in an operational environment. This section will discuss facilities that were used in the development, test and operation of the systems described in previous sections.

Reduced-Gravity Facilities. Three different approaches have been used to simulate or reproduce the reduced-gravity experienced in free space, on the lunar surface, and that will be experienced on the Martian surface: mechanical counterbalances, neutral buoyancy water tanks, and aircraft flying parabolic trajectories. Each approach has strengths and weaknesses, but as a group they tend to be complementary in the process of fielding an operational system. This section will describe an example of each of these approaches that has served across a number of different programs to illustrate the concept.

Mechanical Counterbalance. One of the simplest means of simulating a reduced-gravity environment is to use a mechanical means of counteracting the weight of the test subject or system. This can be accomplished with something as simple (and crude) as a counterweight attached mechanically to the test item or with increasing levels of sophistication, such as the use of a feedback controlled, pneumatically driven mechanism. These weight relief systems have been used in a wide number of venues, such as the circular walking track, illustrated in Figure B.5-1, or in environmental (i.e., thermal/vacuum) chambers (discussed below).

Neutral Buoyancy Water Tanks. Neutral buoyancy water tanks are another tool for the design, testing and development of future space systems. For the development team, this environment provides a means of testing primarily the operational aspects of a concept for extended periods of time. For the astronaut, such a facility provides important pre-flight training in becoming familiar with planned crew activities and with the dynamics of body motion under weightless conditions.

NASA's first neutral buoyancy facility was the **Neutral Buoyancy Simulator (NBS)**, established in 1968 at the Marshall Space Flight Center. It was used primarily to test and refine techniques and hardware used in space. In 1973, engineers used the NBS to develop the procedures that saved Skylab after the spacecraft suffered damaged to its sunshield during launch. In the early 1980s, engineers used the simulator to practice the intricate space repair procedures that revitalized the Solar Maximum Mission Satellite. In 1985, after perfecting assembly techniques in the NBS tank, NASA astronauts constructed the first structures (EASE and ACCESS) built in space.



Figure B.5-1. Apollo 13 astronaut Fred Haise during lunar surface simulation training. (NASA photo S70-24009)



Figure B.5-2. Activities on 5 January 1972 during a simulation of film retrieval from the Apollo Telescope Mount (Skylab) in the Marshall Space Flight Center Neutral Buoyancy Simulator.

The NBS facility consists of a 75-ft-wide, 40-ft-deep, 1.3-million-gallon simulation tank; a three-person, double-lock hyperbaric chamber; an overhead crane for lifting hardware into the tank; a floating crane for moving hardware underwater; a removable roof section to accommodate large, one-piece mock-ups; an observing room for visitors; four Shuttle pressure suits with underwater PLSSs and umbilicals; a full-scale Shuttle payload bay mock-up; and a fully operational RMS.

NASA also constructed the **Weightless Environment Training Facility (WETF)** at JSC in 1980. This facility was used to train astronauts for EVA activities associated with the Shuttle, *Mir*, and the ISS until its replacement by the Sonny Carter Training Facility, or Neutral Buoyancy Laboratory (NBL), in 1997.

The WETF consists of a water-filled pool with dimensions of 25 ft (depth) by 78 ft (length) by 33 ft (width). This tank is large enough to contain a mock-up of the Orbiter payload bay and various payloads (see Figure B.5-3).

The Soviet, and now Russian, space program also has a water tank facility at its Star City training center. The Neutral Buoyancy Laboratory uses a tank that is 23 m in diameter, 12 m deep, and contains 5000 m³ of water.

Aircraft Flying Parabolic Trajectories. It has long been known that aircraft flying parabolic trajectories can produce brief periods of reduced weight, simulating different gravity fields, at the top portion of the parabola. This flight path is illustrated in Figure B.5-5. However, the maneuver can be modified to provide any level of g-force less than one g. Some typical g-levels used on different tests, along with the corresponding time for each maneuver, are as follows:

- Negative-g: (-0.1 g): Approximately 15 seconds
- Zero-g: Approximately 25 seconds
- Lunar-g: (one-sixth g): Approximately 40 seconds
- Martian-g: (one-third g): Approximately 30 seconds

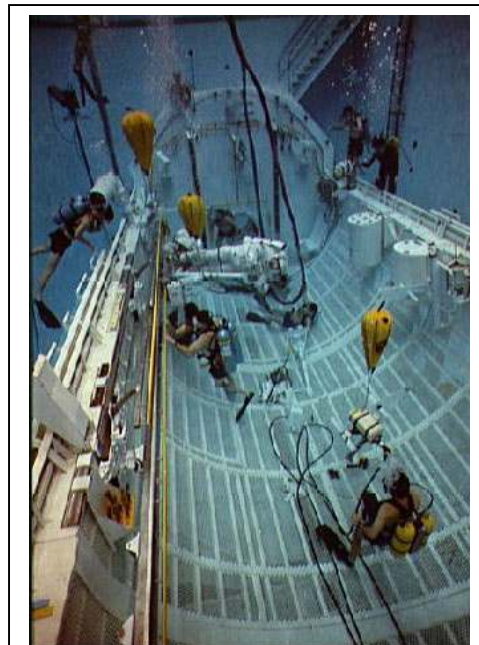

Figure B.5-3. STS-37 crewmembers train for a planned EVA in JSC's WETF. (NASA photo S89-50846)

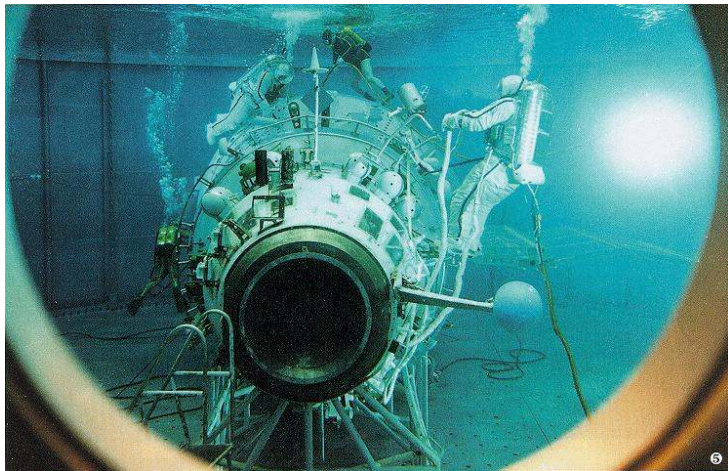

Figure B.5-4. EVA training at Star City.

The Reduced-Gravity Program operated at the NASA Manned Spacecraft Center (now the Johnson Space Center) was started in 1962 to investigate human and hardware reactions to operating in a weightless environment. The reduced-gravity environment is obtained with a specially modified KC-135A turbojet transport. A typical mission is 2 to 3 hours long and consists of 30 to 40 parabolas. These parabolas can be flown in succession or with short breaks between maneuvers to reconfigure

test equipment. The KC-135A cargo bay test area is approximately 60 ft long, 10 ft wide, and 7 ft high. The aircraft is equipped with electrical power, an overboard vent system, and photographic lights. Air and nitrogen sources are also available.

Other aircraft from the U.S., Russia, and other countries are also used for this type of simulation. For example, the Russians use an IL-76 MDK aircraft that can perform up to 20 parabolas during one flight, simulating zero-g conditions for up to 30 seconds in each parabola.

(Adapted from <http://jsc-aircraft-ops.jsc.nasa.gov/kc135>; accessed on Jan 31, 2003.)

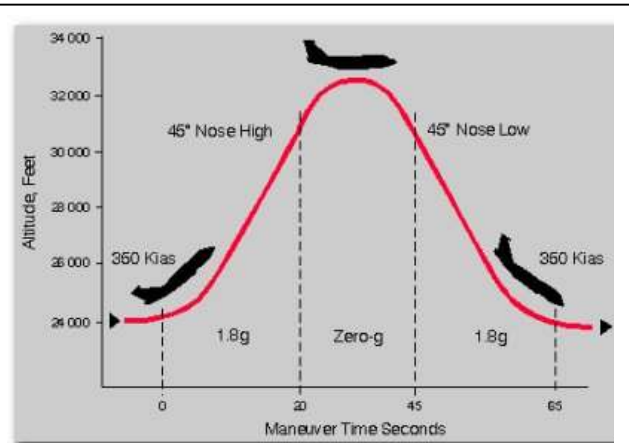

Figure B.5-5. A typical parabolic flight profile used to simulate a reduced-gravity environment.

One-G Facilities. This category of the EVA system hierarchy is set aside for environmental chambers and facilities set up to test EVA systems in appropriate environmental conditions other than reduced gravity. Typically, this means vacuum and thermal extremes encountered in free space and on planetary surfaces. As with reduced-gravity facilities, there have been many facilities, some set up for unique circumstances others for general purpose, that have been used in the past to support EVA system development, testing, and training. This section will only describe representative examples of several general-purpose facilities, categorized primarily by the size of the test chamber or facility, to illustrate the range of facilities used. Further information on other specific chamber or test facilities can typically be found on the web sites of the NASA Center or other organization operating that facility.

The Eleven-Foot and Two-Foot Chambers. These two collocated chambers at JSC are used for EVA suit and suit component test and certification.

The Eleven Foot chamber is the Space Suit development and certification test complex for JSC. This chamber is human-rated and features a treadmill, crew weight relief system, and the necessary support systems for reduced pressure crew operations. Its physical dimensions are 3.4



Figure B.5-6. Astronaut Alan Shepard (Apollo 14) with MET aboard KC-135. (NASA photo S70-53479)

m diameter by 5.8 m long (11.0 ft by 19.0 ft) with dual airlock compartments of 2.7 m and 3.0 m lengths (9.0 ft and 10.0 ft). It can produce a vacuum of 0.01 torr (1 Pa) (equivalent to 76,200 m or 250,000 ft altitude) but is not equipped to simulate differing thermal environments.

The Two Foot Thermal/Vacuum Space Suit Boot/Glove Test Chamber is attached to the outerlock providing an environment for evaluating space suit boots and gloves. It can also be used to provide requested profiles of outgassing, water boiloff, and/or leaks for future prototype boot/glove systems.

The Thermal/Vacuum Test Complex. The Thermal/Vacuum Test Complex consists of the two largest chambers at JSC. The facility provides full-scale testing of large systems and human testing/training in a high-fidelity simulated space environment.

Chamber A is the largest of the JSC thermal/vacuum test facilities. The major structural elements of the chamber are the 13.7-m (45-ft)-diameter floor (that will support a 68,100-kg (150,000-lb) concentric load), the 12.2-m (40-ft)-diameter access door, and the dual crewlocks at the floor level and at the 9.4-m (31-ft) level. The chamber floor can be rotated by manual control 180 degrees in either direction and rotates about the chamber's vertical axis at continuously variable angular velocities up to a maximum of 0.8 rpm. To support test articles, the facility has numerous thermal carts capable of providing precise thermal control to temperatures as low as 144 K. The carts provide cooling and heating via various heat transfer media with a

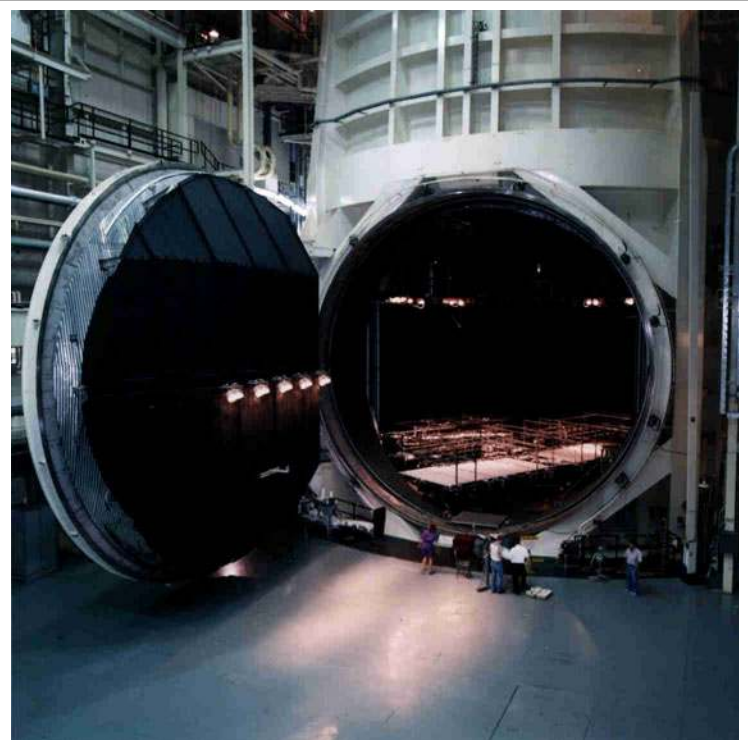

Figure B.5-7. Chamber A showing the 12.2-m-diameter access door in the open position. Note test personnel standing just below the access opening for scale.

combined capacity of 11,700 kW (400 kbtu) cooling and 7,900 kW (270 kbtu) heating. The dual crewlocks, when configured in a human-rated mode, provide a means for the test crew to move from ambient air pressure to the thermal/vacuum environment and back. They also provide for the maintenance of rescue personnel at convenient intermediate pressures during crew test operations. When the inner door is bolted, either of the crewlocks can be used as an altitude chamber for independent tests.

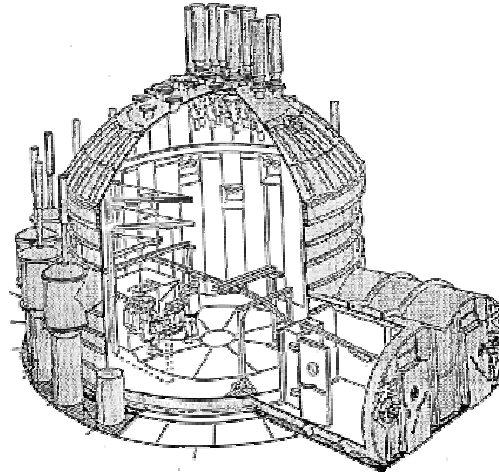

Figure B.5-8. Line drawing of Chamber B in the Thermal/Vacuum Test Complex.

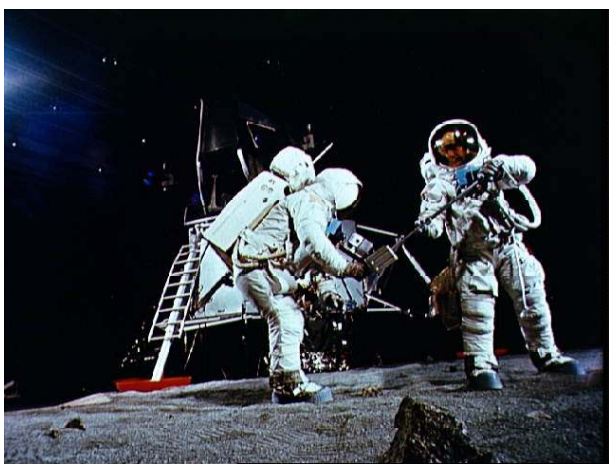

Figure B.5-9. Apollo 11 crewmembers participate in a rehearsal of EVA activities on a simulation of the Moon's surface constructed at the Manned Spacecraft Center. (NASA photo S69-32243)

Chamber B, with roughly one tenth of the internal volume of Chamber A, can handle a variety of smaller scale tests. It is a human-rated chamber equipped with a traversing monorail that provides weight relief to one suited crewmember at a time. The traversing monorail allows two degrees of freedom inside the chamber and 18.6 m² (200 ft²) of working space. Major structural elements of the chamber are the removable top head, the fixed chamber floor, dual crewlocks at the floor level, and a load bearing floor area of 6.1 m (20 ft) in diameter that will support a concentric load of 34,000 kg (75,000 lb). Dual crewlocks provide access to the test articles as well as a means of transporting test crewmembers to

the test environment and back during tests. The crewlocks can also be used as an altitude chamber for independent tests. One crewlock is equipped with a water deluge system and other features that permit its use for crew operations with oxygen-rich residual atmospheres. Additional test support equipment includes an internal jib crane, mass spectrometers, infrared cameras, television cameras, and two rolling bridge cranes with a capacity of 45,000 kg (100,000 lb), which are used to remove the chamber top and insert large test articles. A solar simulation array, mounted on the top head, is modular in design to facilitate changes in location and beam size. The solar simulation modules are on axis with xenon lamp sources. The source and collection optics are located outside the chamber, with collimating optics inside the chamber.

(Adapted from <http://ctsd.jsc.nasa.gov/ec4/Facilities/Vacuum.html>; accessed on Jan 31, 2003.)

Analog Sites. Analog sites have been, and will continue to be, important for EVA system development, testing, and training as other planetary surfaces are explored. As Apollo is the only historical program that explored another planetary surfaces, this section will discuss some of the analogs used during that program. These sites can be grouped into two general categories: those specifically constructed to be representative of a particular site or feature on the Moon, and those that are naturally occurring on the Earth's surface that were thought to have been created by the same or similar processes and thus should exhibit the same characteristics that would be found on the Moon.

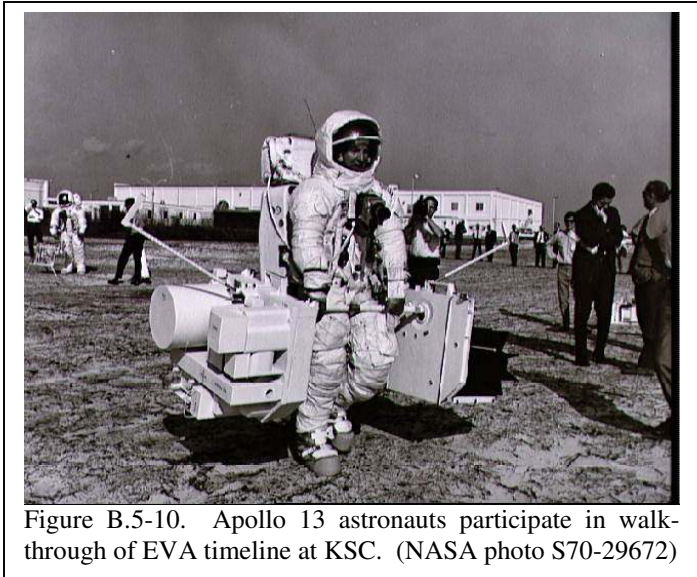

Figure B.5-10. Apollo 13 astronauts participate in walk-through of EVA timeline at KSC. (NASA photo S70-29672)

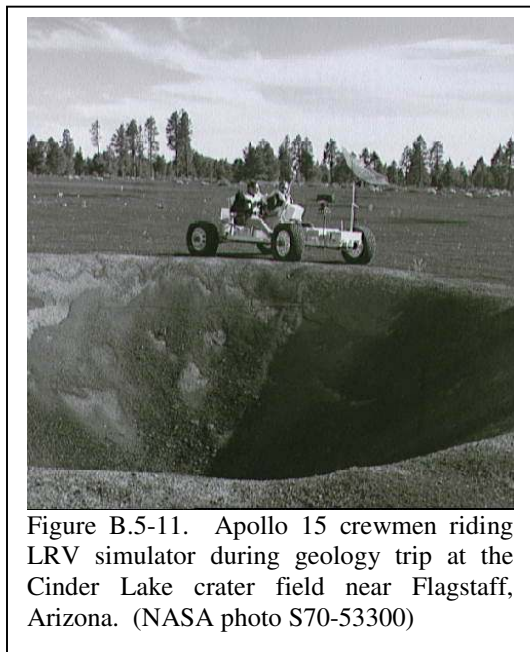

Figure B.5-11. Apollo 15 crewmen riding LRV simulator during geology trip at the Cinder Lake crater field near Flagstaff, Arizona. (NASA photo S70-53300)

In the first category, representative lunar landscapes were constructed at both the Manned Spacecraft Center (now JSC) and at the Kennedy Space Center (see Figures B.5-9 and B.5-10 for sites at each of these respective Centers). In addition, the U.S. Geological Survey used explosives to create several craters, some up to 100 m in diameter, in basaltic regolith (soil) thought to be similar to what would be found on the Moon (see Figure B.5-11).

In the second category, the Apollo astronauts were taken to numerous locations around the world to train them to

recognize what they might see on the lunar surface in preparation for gathering samples, taking photographs, and, in general, relating this information back to the Earth. Figure B.5-12 shows astronauts Lovell and Haise (Apollo 13) during simulation of lunar traverse near the volcanic outflows at Kilauea, Hawaii. Figure B.5-13 shows astronauts Scott and Duke (Apollo 15) collecting soil samples during simulated EVA in the Taos, New Mexico area.



Figure B.5-12. Astronauts Lovell and Haise during simulation of lunar traverse at Kilauea, Hawaii. (NASA photo S70-20253)

Mission Support Facilities. During all EVAs up to the present time, there has been dedicated support provided by ground personnel. This support can be divided into two broad categories: (1) monitoring the performance of the human crew and the EVA equipment, and (2) monitoring and reacting to the specific tasks being conducted.

The primary purpose for the first category of support is to provide for the safety of the crew. This is accomplished by monitoring various performance parameters to watch for off-nominal values or trends that could lead to unsafe conditions if no action is taken.

The personnel providing this support are experts in their particular hardware system or operational procedure. As such, they serve not only to recognize off-nominal conditions but also as an expert resource to recommend the best source of action



Figure B.5-14. View of Medical Support Room in Mission Control Center during Apollo 16. (NASA photo S72-35460)

under the conditions at that time. This category of support is also used to track other data, such as the use of consumables, or longer-term performance trends that could impact future EVAs.

The primary purpose for the second category of support is to assist in achieving the task objectives for the EVA. During the Apollo missions, a mission support “backroom” was set up for use by scientists supporting the surface EVAs. These scientists monitored the highly scripted EVA timeline, answering questions or providing suggestions to the crew in real time, in particular when stops were made along a traverse to examine a particular site in more detail. During maintenance or repair EVAs (e.g., Hubble Space Telescope servicing missions), expert personnel for the payloads or systems being serviced are assembled, again to answer questions or provide suggestions to the crew in real time as they progress through the servicing procedure.

No single example can serve to illustrate the variety of mission support facilities that have been used during the history of EVAs. Each is established to satisfy the needs of a particular mission, based on the best understanding of the EVA tasks prior to flight. Thus, the missions support facility could be as little as a single



Figure B.5-13. Members of Apollo 15 crew collect soil samples during simulated EVA near Taos, New Mexico. (NASA photo S71-23772)

These scientists monitored the highly scripted EVA timeline, answering questions or providing suggestions to the crew in real time, in particular when stops were made along a traverse to examine a particular site in more detail. During maintenance or repair EVAs (e.g., Hubble Space Telescope servicing missions), expert personnel for the payloads or systems being serviced are assembled, again to answer questions or provide suggestions to the crew in real time as they progress through the servicing procedure.

During the Apollo missions, a mission support “backroom” was set up for use by scientists supporting the surface EVAs. These scientists monitored the highly scripted EVA timeline, answering questions or providing suggestions to the crew in real time, in particular when stops were made along a traverse to examine a particular site in more detail. During maintenance or repair EVAs (e.g., Hubble Space Telescope servicing missions), expert personnel for the payloads or systems being serviced are assembled, again to answer questions or provide suggestions to the crew in real time as they progress through the servicing procedure.



Figure B.5-15. Seismometer readings studied in Mission Control Center. (NASA photo S71-41422)

console or an entire room with associated personnel and workstations. What is common to these various rooms is their need for data from the systems being monitored and the means to display this information to the support facility personnel. In this respect, mission support rooms have progressed with this technology, progressing from strip charts in a dedicated physical location to computer workstations in distributed locations.



Figure B.5-16. JSC Life Sciences Control Center.

APPENDIX C: EVA SYSTEM CURRENT STATE OF THE ART

This Appendix builds on the general history of EVA systems described in Appendix B by describing the current state of the art for the EVA system elements described in Section 3 and Appendix A. These descriptions will focus on the current capabilities of these system elements, but also discuss the differences relative to the historical systems described previously and identify aspects that are candidates for significant enhancement.

The next two sections will describe EVA garments, including a specific discussion of boots and gloves, and portable life support, all items under Element 1.1 of the functional breakdown used in this study. This is followed by a discussion of teleoperated robotic devices (part of Element 1.2), transportation systems, including airlocks (Element 1.3), and support systems (Element 1.4). Other items in the functional breakdown are beyond the current state of the art, and thus will be discussed in Section 4 on future system concepts.

C.1 EVA Garments and Portable Life Support

There are currently two EVA garments and life support systems in operational use—the U.S. Shuttle EMU and the Russian Orlan-M, each with its own PLSS. While both were discussed briefly in the previous section as historical developments, they continue to evolve to meet the needs of current and near-future missions, such as Hubble Space Telescope servicing and ISS assembly and maintenance. In particular, emphasis has been placed on development of more capable gloves to improve the mobility and dexterity of astronauts performing EVA tasks. This section will discuss the Shuttle EMU and its PLSS in more detail to characterize the current state of the art for EVA in a microgravity environment.

There are also a number of experimental or research EVA garments in use for the primary purpose of re-establishing a planetary surface EVA capability, building on lessons learned from the Apollo missions and addressing the forecasted needs of lunar and Mars mission suits. Three of these suits will be discussed in this section to illustrate the type of development effort under way.

Shuttle Extravehicular Mobility Unit. The Shuttle EMU is the first operational U.S. space suit built specifically for EVA. The Shuttle EMU consists of the Primary Life Support System (PLSS) and the Space Suit Assembly (SSA). This suit has a total mass of approximately 113 kg (approximately 250 lb) with a nominal operating pressure is 29.7 kPa (4.3 psi). The SSA and PLSS consists of 19 major components (refer to Figure C.1-1; the item numbers in the following list correspond to the numbers in the figure):

- 1) Primary Life Support System. A backpack unit containing the oxygen supply, carbon dioxide removal equipment, caution and warning system, electrical power, water-cooling equipment, ventilating fan, and radio.
- 2) Display and Control Module (DCM). Chest-mounted control module containing all controls, a digital display, and the external liquid, gas, and electrical connections. The DCM also has the primary purge valve for use with the secondary oxygen pack.

- 3) Electrical Harness (EH). (not shown) A harness worn inside the suit to provide bioinstrumentation and communications connections to the PLSS.
- 4) Secondary oxygen pack. (not shown) Two oxygen tanks with a 30-minute emergency supply, valve, and regulators. The secondary oxygen pack is attached to the base of the PLSS.
- 5) Service and Cooling Umbilical. (not shown) Connects the airlock support system to the EMU to support the astronaut before EVA and to provide in-orbit recharge capability for the PLSS. The Service and Cooling Umbilical contains lines for power, communications, oxygen and water recharge, and water drainage. It conserves PLSS consumables during EVA preparation.
- 6) Battery. (not shown) Supplies electrical power for the EMU during EVA. The battery is rechargeable in orbit.
- 7) Contaminant Control Cartridge. (not shown) Cleanses suit atmosphere of contaminants with an integrated system of lithium hydroxide, activated charcoal, and a filter contained in one unit. The Cartridge is replaceable in orbit.

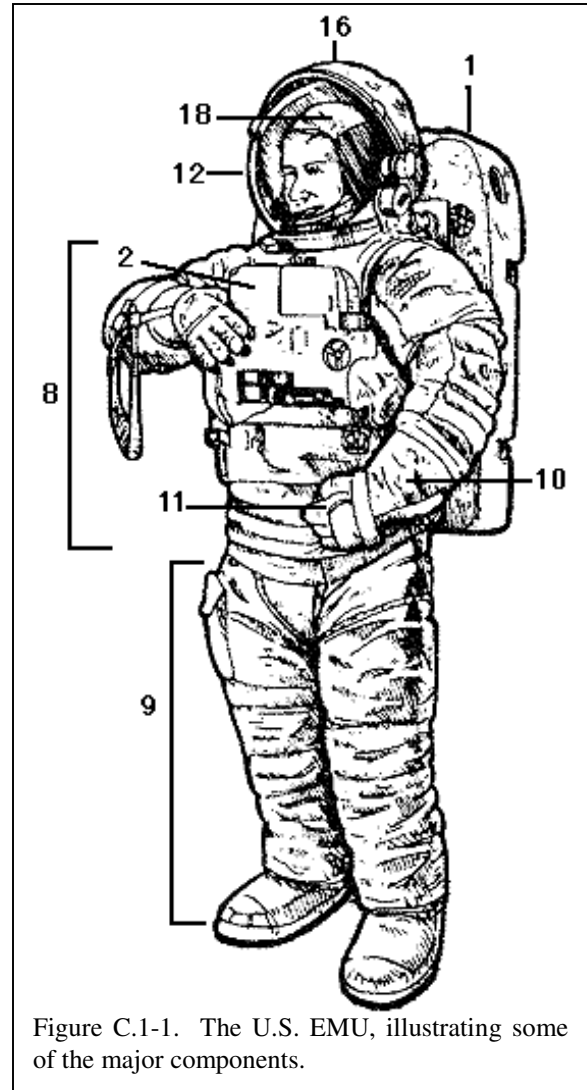
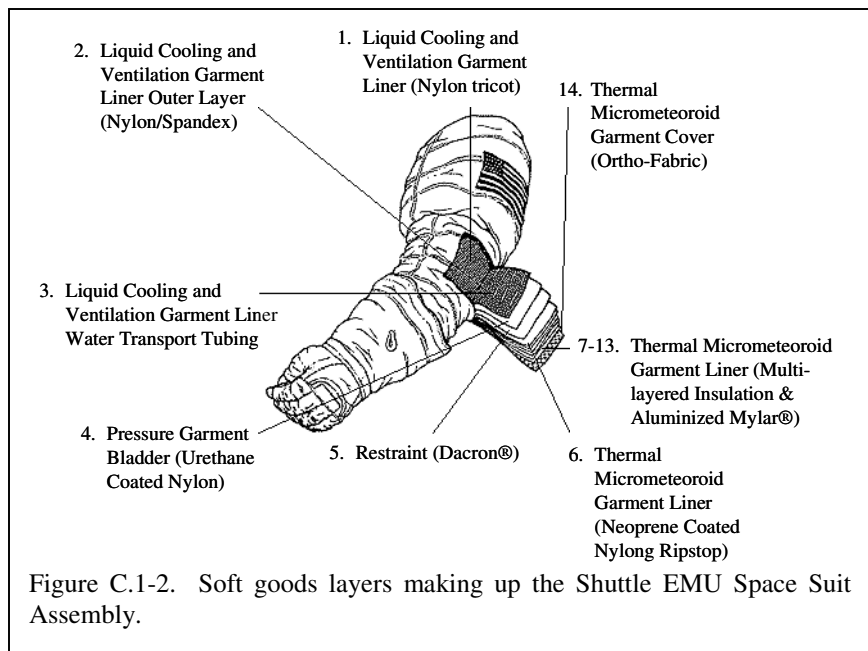

Figure C.1-1. The U.S. EMU, illustrating some of the major components.

- 8) Hard Upper Torso (HUT). Upper torso of the suit, composed of a hard fiberglass shell. It provides structural support for mounting the PLSS, DCM, arms, helmet, In-Suit Drink Bag, EH, and the upper half of the waist closure. The HUT also has attachments for mounting a miniworkstation tool carrier.
- 9) Lower Torso. Spacesuit pants, boots, and the lower half of the closure at the waist. The lower torso also has a waist-bearing for body rotation and mobility and brackets for attaching a safety tether.
- 10) Arm. Shoulder joint and armscye (armhole) bearing, upper arm bearings, elbow joint, and glove-attaching closure.
- 11) Glove. Wrist bearing and disconnect, wrist joint, and fingers. One glove has a wristwatch sewn onto the outer layer. The gloves have tethers for restraining small tools and equipment. Generally, crewmembers wear thin fabric comfort gloves with knitted wristlets inside. These are discussed in more detail in a separate section below.

- 12) Helmet. Plastic pressure bubble with neck disconnect ring and ventilation distribution pad. The helmet has a backup purge valve for use with the secondary oxygen pack to remove expired carbon dioxide.
- 13) Liquid Cooling and Ventilation Garment (LCVG). (not shown) Long, underwear-like garment worn inside the pressure layer. It has liquid-cooling tubes, gas ventilation ducting, and multiple water and gas connectors for attachment to the PLSS via the HUT.
- 14) Urine Collection Device. (not shown) Urine collection device consisting of a roll-on cuff adapter and storage bag (for male crewmembers). The Urine Collection Device is disposable after use.
- 15) Disposable Absorption Containment Trunk. (not shown) Urine-collection garment consisting of a pair of shorts constructed from five layers of chemically treated absorbent, non-woven, fibrous materials (for female crewmembers).
- 16) Extravehicular Visor Assembly. Assembly containing a metallic gold-covered Sun-filtering visor, a clear thermal-impact protective visor, and adjustable blinders that attach over the helmet. In addition, four small "head lamps" are mounted on the assembly, and a TV camera transmitter may also be added.
- 17) In-Suit Drink Bag. (not shown) Plastic water-filled pouch mounted inside HUT. A tube projecting into helmet permits crewmember to drink through a straw.
- 18) Communications Carrier Assembly. Fabric cap with built-in earphones and a microphone for use with the EMU's radio.
- 19) Airlock Adapter Plate. (not shown) Fixture for mounting and storing the EMU inside the airlock and for donning the suit.

Shuttle EMU Space Suit Assembly. The SSA is built around the fiberglass HUT. Water, oxygen, electricity, and data pass between the PLSS and the HUT through an interface pad behind the astronaut's left shoulder. Most SSA components can fit men and women from the 5th to 95th percentiles of body size. There are four HUT sizes, six waist-bearing sizes, and two boot sizes (the latter with six sizes of sizing insert "slippers"). There are also nine standard glove sizes, but generally astronauts opt for customized gloves when possible. This is the only customizable part of the EMU, pointing up the importance placed on



adequate gloves in EVA work. When added together, the total mass of the SSA is approximately 38 kg (85 lb), depending on the specific sized components used.

The SSA has 14 layers to protect astronauts on EVAs. The inner layers comprise the LCVG. First comes a liner of Nylon tricot over which is a layer of spandex fabric laced with plastic tubing. Next comes the pressure bladder layer of urethane-coated nylon and fabric layer of pressure-restraining Dacron®. Above the bladder and restraint layer is a liner of Neoprene coated Nylon Ripstop. This is followed by a seven-layer thermal micrometeoroid garment of aluminized Mylar®, laminated with Dacron® scrim. The outer layer of the suit is made of Ortho-Fabric which consists of a blend of Gortex®, Kevlar®, and Nomex® materials.

(Adapted from <http://quest.arc.nasa.gov/space/teachers/suited/5emu4.html>; accessed on Jan 14, 2003.)

Shuttle EMU Boots and Gloves. Current EMU boots are constructed with soles that were not designed for walking but are perfectly adequate for maneuvering in zero gravity and for reacting loads imposed on an EVA crewmember when secured in a foot restraint. Any return to walking on a planetary surface will require some development effort, but as discussed in the experimental suit section (see below), work in this area is already under way.

The basic EMU glove design has been evolving since the beginning of the Space Shuttle Program. The Shuttle EVA glove started with the 1000 Series glove and has evolved to the Phase VI Series glove that is flying today. Originally based upon nine standard hand sizes, the Shuttle glove program initially provided a “closest fit” glove sizing capability. Subsequent development of the 4000 Series gloves included customization for crewmembers that did not adequately fit into a standard size range. The fundamental approach remains the same in the 4000 Series glove today.

To construct one of these early series Shuttle gloves (1000 Series through the 4000 Series), a hand cast of the subject is taken. From this, measurements are gathered and compared to the standard sizes of gloves. If no fit is possible within the standard size range, a custom glove is needed. Tooling is prepared using epoxy resin and handcrafted methods. This relies heavily on “old world” craftsmanship to create consistency among different glove sizes. For the restraint and TMG, the flat patterns are selected from the closest size. These patterns are modified to provide appropriate finger lengths and circumferences, and incorporate other changes deemed necessary to promote an adequate fit. This pattern making includes mostly hand-generated patterns and limited CAD-assisted design, but for manufacturing, all fabric parts are hand cut from the paper pattern templates.

Through these generations (1000 Series through the 4000 Series), material changes were the primary focus of the evolution. These changes did help to

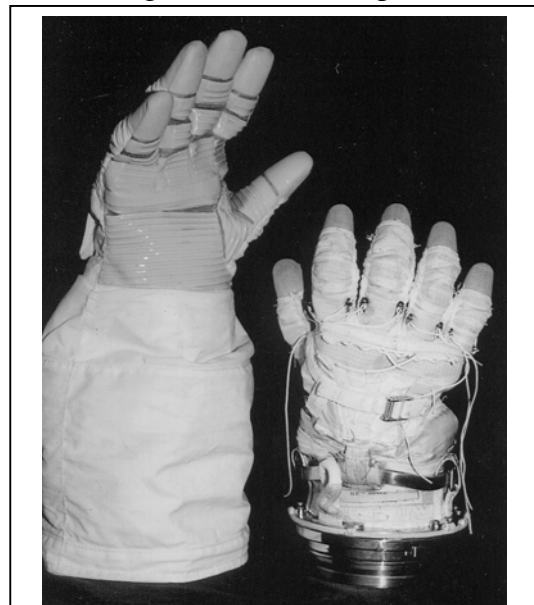

Figure C.1-3. The 4000 Series glove assembly.

produce a better glove, but basic design, hardware and patterning philosophy did not change significantly. By the early nineties, this 4000 Series glove and its performance had evolved as far as the basic design would allow. In an attempt to make a revolutionary step in glove design for ISS assembly, a completely new glove was developed retaining little of the previous design except for some of the materials technology. This design incorporated materials technology lessons learned from the 4000 Series glove program, but otherwise attempted and made quantum improvements in glove design.

The Phase VI glove is the successor to the 4000 Series. The Phase VI design consolidates all of the advanced technologies of the advanced glove programs with the development of a new, advanced softgoods wrist. Its purpose is to provide custom fit gloves that promote improved dexterity, reduced fatigue, and provide a high level of user comfort compared to current and previous glove designs. The Phase VI glove design includes laser scanning technology, three-dimensional computer modeling, stereo lithography, laser cutting technology and CNC machining. It is through the use of these advanced technologies that a higher-performance Phase VI custom glove can be developed faster, with higher accuracy and at a lower cost than previous glove designs.

Mimicking the shape of the restraint, the bladder provides the conformal pressure-retaining layer of the glove. For Phase VI, a one-piece urethane bladder was designed that exhibits little to no wrinkling when integrated into the glove; this significantly improves the fit and performance. To reduce finger torque, convolute ridges are incorporated to provide additional material run length for flexion.

The Phase VI hand is designed to be anthropomorphically correct to the crewmember's hand. Using pleated, lightweight polyester fabric, the fingers and thumb mobility joints are designed

as all fabric assemblies to decrease torque and increase fingertip tactility. By closely fitting the hand, finger and thumb joint torque is reduced and overall comfort is achieved.

In order to meet the thermal challenges of ISS assembly, the Phase VI glove has also been designed to include improved insulation and an active heating system. Using the geometry of the subject's hand, felt insulation has been placed in areas of prime surface contact. This includes selective areas of the palm and the fingertips. By reducing unneeded insulation, overall TMG performance has been further increased. In recent cooperative NASA/Zvesda redesign efforts, the Russian Orlan glove TMG has been modified to include similar insulation configuration to replicate Phase VI thermal performance.

The Phase VI glove incorporates an active heating system that consists of resistive element heaters located at the fingertips. This system originated as a 3-volt system designed to operate



off remotely located battery pack. A recent battery redesign has resulted in the evolution of the heater system to a 12-volt design.

Finally, the Phase VI glove TMG has incorporated features to allow on-orbit replacement of a damaged or worn-out TMG.

Under the Phase VI Implementation Program, Phase VI flight gloves are currently being fabricated or have been delivered for 57 EVA crewmembers. Training gloves for nearly half of these customizations have been delivered and are currently being used in NBL training. As part of an ongoing effort, named EVA crewmembers are fitchecked in “close-fit” gloves that have been customized for other crewmembers, eliminating the need to create a custom glove for some crewmembers. To maintain the high level of performance of this design, strict criteria are evaluated to determine the acceptability of a “non-custom” fit. If all parameters are not met, a custom glove is recommended.

(Adapted, in many cases directly quoted, from D. Graziosi et al., 2001.)

Shuttle EMU Life Support System. The EMU life support system is an advanced version of the Apollo PLSS (see Appendix B), providing life support, voice communications, and biomedical telemetry for EVAs lasting as long as seven hours. There are three major components of this life support system—the Primary Life Support System (also using the acronym PLSS), the secondary oxygen pack, and the DCM.

Within its dimensions of 80 by 58.4 by 17.5 cm, the **Primary Life Support System** (PLSS) contains five major groups of components for life support (see Figure C.1-5). These are the oxygen-ventilating, condensate, feedwater, liquid transport, and primary oxygen circuits.

The oxygen-ventilating circuit is a closed-loop system. Oxygen is supplied to the system from the primary oxygen circuit or from a secondary oxygen pack that is added to the bottom of the PLSS for emergency use. The circulating oxygen enters the suit through a manifold built into the HUT. Ducting carries the oxygen to the back of the space helmet, where it is directed over the head and then downward along the inside of the helmet front. Before passing into the helmet, the oxygen warms sufficiently to prevent fogging of the visor. As the oxygen leaves the helmet and travels into the rest of the suit, it picks up carbon dioxide and humidity from the crewmember's respiration. More humidity from perspiration, some heat from physical activity, and trace contaminants are also picked up by the oxygen as it is drawn into the ducting built into the LCVG. A centrifugal fan, running at nearly 20,000 rpm, draws the contaminated oxygen back into the PLSS at a rate of about 0.17 m³ per minute, where it passes through the Contaminant Control Cartridge.

Carbon dioxide and trace contaminants are filtered out by the lithium hydroxide and activated charcoal layers of the cartridge. The gas stream then travels through a heat exchanger and sublimator for removal of the humidity. The heat exchanger and sublimator also chill water that runs through the tubing in the LCVG. The humidity in the gas stream condenses out in the heat exchanger and sublimator. The relatively dry gas (now cooled to approximately 13° Celsius) is directed through a carbon dioxide sensor before it is recirculated through the suit. Oxygen is added from a supply and regulation system in the PLSS as needed. In the event of the failure of the suit fan, a purge valve in the suit can be opened. It initiates an open loop purge mode in

which oxygen is delivered from both the primary and secondary oxygen pack. In this mode, moisture and the carbon dioxide-rich gas are dumped outside the suit just before they reach the Contaminant Control Cartridge.

One of the by-products of the oxygen-ventilating circuit is moisture. The water produced by perspiration and breathing is withdrawn from the oxygen supply by being condensed in the sublimator and is carried by the condensate circuit. (The small amount of oxygen that is also carried by the condensate circuit is removed by a gas separator and returned to the oxygen-ventilating system.) The water is then sent to the water-storage tanks of the feedwater circuit and added to their supply for eventual use in the sublimator. In this manner, the PLSS is able to maintain suit cooling for a longer period than would be possible with just the tank's original water supply.

The function of the feedwater and the liquid transport circuits is to cool the astronaut. Using the pressure of oxygen from the primary oxygen circuit, the feedwater circuit moves water from the storage tanks (three tanks holding a total of 4.57 kg of water) to the space between the inner surfaces of two steel plates in the heat exchanger and sublimator. The outer side of one of the plates is exposed directly to the vacuum of space. That plate is porous and, as water evaporates through the pores, the temperature of the plate drops below the freezing point of water. Water still remaining on the inside of the porous plate freezes, sealing off the pores. Flow in the feedwater circuit to the heat exchanger and sublimator then stops.

On the opposite side of the other steel plate is a second chamber through which water from the liquid transport circuit passes. The liquid transport circuit is a closed-loop system that is connected to the plastic tubing of the LCVG. Water in this circuit, driven by a pump, absorbs body heat. As the heated water passes to the heat exchanger and sublimator, heat is transferred through the aluminum wall to the chamber with the porous wall. The ice formed in the pores of that wall is sublimated by the heat directly into gas, permitting it to travel through the pores into space. In this manner, water in the transport circuit is cooled and returned to the LCVG. The cooling rate of the sublimator is determined by the workload of the astronaut. With a greater workload, more heat is released into the water loop, causing ice to be sublimated more rapidly and more heat to be eliminated by the system.

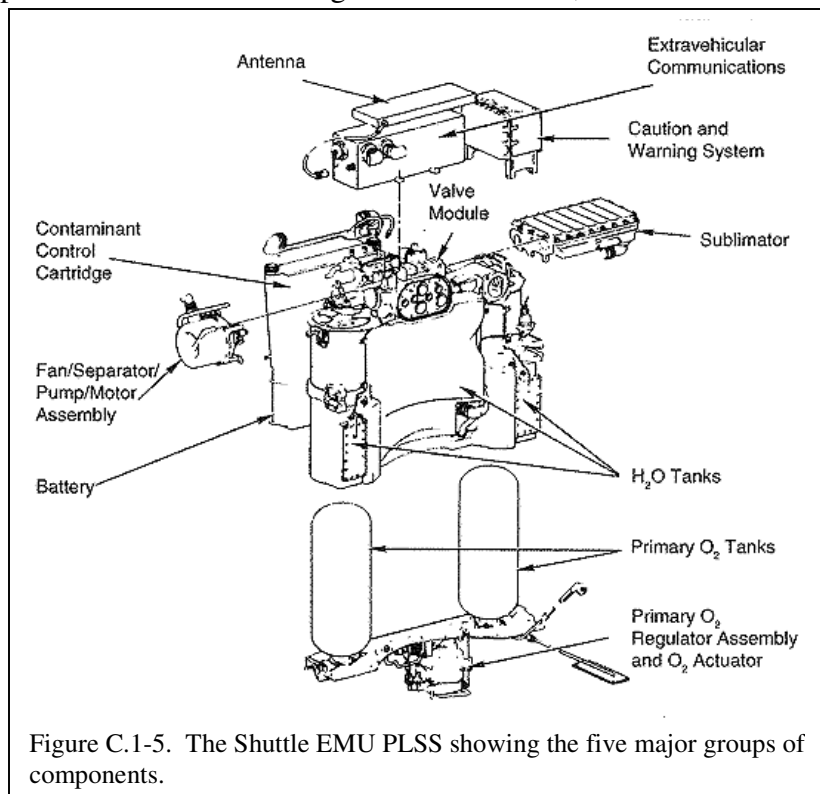

Figure C.1-5. The Shuttle EMU PLSS showing the five major groups of components.

The last group of components in the PLSS is the primary oxygen circuit. Its two tanks contain a total of 0.54 kg of oxygen at a pressure of 5,860.5 kilopascals, enough for a normal 7-hour EVA. The oxygen of this circuit is used for suit pressurization and breathing. Two regulators in the circuit step the pressure down to usable levels of 103.4 kilopascals and 29.6 kilopascals. Oxygen coming from the 103.4-kilopascal regulator pressurizes the water tanks, and oxygen from the 29.6-kilopascal regulator goes to the ventilating circuit.

To insure the safety of astronauts on EVAs, a **secondary oxygen pack** is added to the bottom of the PLSS. The two small tanks in this system contain 1.2 kg of oxygen at a pressure of 41,368.5 kilopascals. The secondary oxygen pack can be used in an open-loop mode by activating a purge valve or as a backup supply should the primary system fall to 23.79 kilopascals. The supply automatically comes on line whenever the oxygen pressure inside the suit drops to less than 23.79 kilopascals.

If the DCM purge valve (discussed below) is opened, used-oxygen contaminants and collected moisture dump directly out of the suit into space. Because oxygen is not conserved and recycled in this mode, the large quantity of oxygen contained in the secondary oxygen pack is consumed in only 30 minutes. This half-hour still gives the crewmember enough time to return to the Orbiter's airlock. If carbon dioxide control is required, the helmet purge valve may be opened instead of the DCM purge valve. That valve has a lower flow rate than the DCM valve.

The final major component of the Shuttle EMU life support system is the **Display and Control Module**. A small, irregularly shaped box, the DCM is mounted to the front of the EMU HUT and houses a variety of switches, valves, and displays (see Figure C.1-7). Along the DCM top are four switches for power, feedwater, communications mode selection, and caution and warning. A suit-pressure purge valve projects from the top at the left. It is used for depressurizing the suit at the end of an EVA and can be used in an emergency to remove heat and humidity when oxygen is flowing from both the primary and secondary oxygen systems. Near the front on the top is an alphanumeric display. A microprocessor inside the PLSS permits astronauts to monitor the condition of the various suit circuits by reading the data on the display.

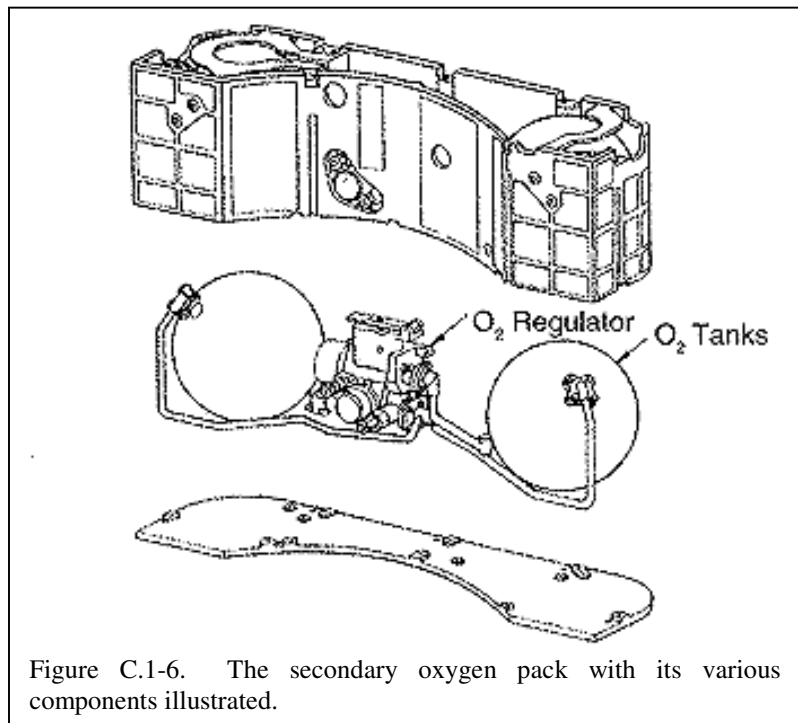
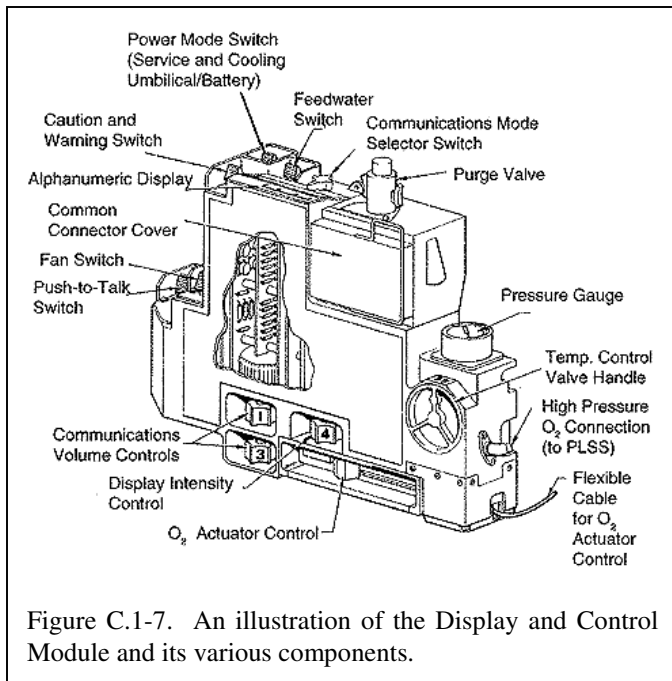

Figure C.1-6. The secondary oxygen pack with its various components illustrated.



Stepped down from the top of the DCM, on a small platform to the astronaut's right, is a ventilation-fan switch and a push-to-talk switch. The astronaut has the option of having the radio channel open at all times or only when needed.

(Adapted from <http://quest.arc.nasa.gov/space/teachers/suited/5emu4.html>; accessed on Jan 14, 2003)

Orlan-M. The currently configured Orlan-M space suit is designed to provide life support equipment and a mobile pressure enclosure necessary for a crewmember to perform EVAs on the ISS while in Earth orbit. The Orlan space suit was first developed in the 1960s to support the attempted Soviet lunar program and

has steadily evolved ever since.

The Orlan-M is an integrated assembly, consisting primarily of the SSA and the Autonomous Life Support Subsystem (ALSS). The Orlan is built around a rigid torso unit to which are attached soft, adjustable limb units. A unique feature of this suit is that it is donned and doffed by means of a rigid hatch built into the back of the torso unit. This hatch is also the mounting location for the ALSS, thus placing it within the pressurized volume of the suit. The entire space suit, in its EVA configuration, has a mass of approximately 110 kg (242 lb) with a nominal operating pressure of 40.0 kPa (5.8 psia) using pure oxygen. The -M configuration suit is designed to provide the following:

- A maximum duration of 8.5 hours for all activities, including time spent in the airlock
- A maximum of 6.0 hours in an autonomous EVA mode
- An average metabolic rate of 300 W (1023 Btu/hr)
- A maximum metabolic rate of 600 W (2047 Btu/hr)

The Orlan-M space suit is one adjustable size with axial restraint system allowing on-orbit sizing. There are two glove sizes available. (See also the general discussion of EVA gloves above.) Figure C.1-8 illustrates the major components of the SSA and ALSS.

Orlan Space Suit Assembly. The Orlan-M SSA consist of the following subassemblies, crew optional equipment, and on-board support systems:

- **Communications Carrier Assembly.** The Communications Carrier Assembly is a leather aviator-type cap worn inside the pressure suit helmet (see Figure C.1-8). It fits over the crewmember's head and is buckled into place with a chin strap. It contains microphones and headphones for communication between crewmembers and receiving caution and warning tones.

- HUT with Helmet. The HUT and helmet separates the interior space of the space suit from the surrounding environment and serves as a base for attaching other assemblies and units of the EVA crewmember's life support system and space suit equipment. Integral to the HUT are passageways for vent air and cooling water. The HUT uses a semi-rigid construction in which the hard shell is made of aluminum alloy and the attached assemblies, such as arm and lower torso assemblies, are made of soft materials. Protection for the HUT is provided by the TMG.
- Arm Assembly. The arm assemblies contain the shoulder pressure bearing, shoulder joint, elbow pressure bearing, elbow joint, wrist pressure bearing, and load-bearing systems. The pressure shell of the sleeve is comprised of two shells: primary and backup. Thermal protection for the arm assemblies is provided by a TMG.
- Lower Torso Assembly. The Orlan-M space suit leg shell contains the lower part of the body, femoral joints, the smooth thigh portion, the knee joints, the smooth knee portion, the ankle joints, and the boot. Bearings are incorporated in the lower leg area. The Assembly is made of soft materials and incorporates four layers (without the TMG): the restraint layer, two bladders, and the lining.
- Helmet Assembly. The helmet assembly is permanently affixed to the HUT. The helmet assembly comprises the protective helmet enclosure, helmet visor, and protective gold-coated Sun visor.
- Glove Assembly. The gloves are the active interface between the crewmember and the work being performed. As such, they must perform a variety of functions while preserving a degree of tactility. The glove must also provide a protective barrier against the natural environment, as well workplace hazards. The glove comprises the following basic components: restraint, bladder, and TMG. The Orlan glove is roughly equivalent to that developed for Apollo (see Appendix B) in terms of mobility and dexterity.
- Outer Garment. The outer garment protects the load-bearing shell from mechanical damage. It is a thermal protective shell and at the same time serves as a shield for the antenna-feeder unit.
- Liquid-Cooled Garment. The liquid-cooled garment is a conformal garment worn under the pressure suit to maintain body temperature. It has tubing woven through the spandex restraint cloth. Cooling water circulates through the tubing near the skin.
- Ventilation System. The Orlan suit ventilation system provides cooled, breathing gas to the crewmember in the helmet region and removes exhaust gas from the limbs.
- In-Suit Drink Bag. The In-Suit Drink Bag is a heat-sealed, flexible container made of polyester base polyurethane film and comes in two sizes. It can hold up the either 21-oz. or 32-oz. container of drinking water for use during EVA. It is mounted to the inner front of the HUT with Velcro and has a tube extending to the neck area.
- EVA Emergency Strap. The EVA emergency strap is a red-colored, emergency-transport telescoping handle and strap, designed to transport an incapacitated crewmember during EVA, and is normally mounted on the upper portion of the backpack frame via two screws.

Orlan-M Autonomous Life Support Subsystem. The Life Support Subsystem consists of the following subsystems, which are briefly described in the following paragraphs:

- oxygen supply system and system to maintain the pressure of the gas medium in the space suit
- ventilation system and gas medium recovery system
- thermal control system
- Space Suit Electrical Console

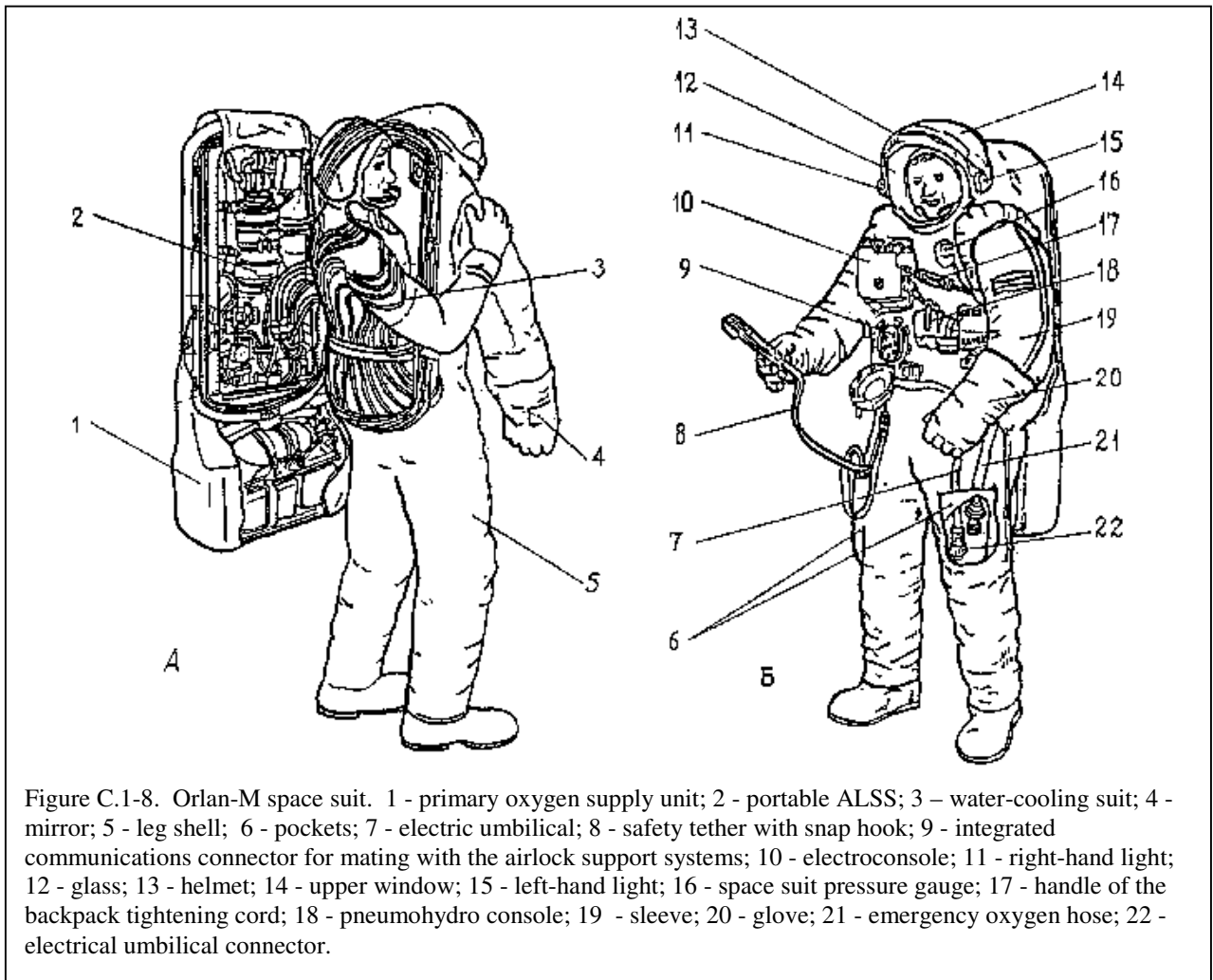

The system also contains a number of radio equipment components, used for both voice communication and telemetry.

The major components of the Orlan-M space suit ALSS were presented in Figure C.1-8 above. The ALSS assemblies are housed primarily in the space suit hatch cover (backpack) and partially inside the body of the shell.

Oxygen Supply System. A diagram of the oxygen supply and gas medium pressure maintenance system in the Orlan-M space suit in the autonomous mode is presented in Figure C.1-9. In the EVA nominal mode, oxygen from the primary tank (Item 3 in Figure C.1-9) under pressure of 45 kPa passes through a valve assembly (Item 24 in Figure C.1-9) of the integrated communications connector (OPK) to the distribution valves of the pneumohydro console (Item 22 in Figure C.1-9).

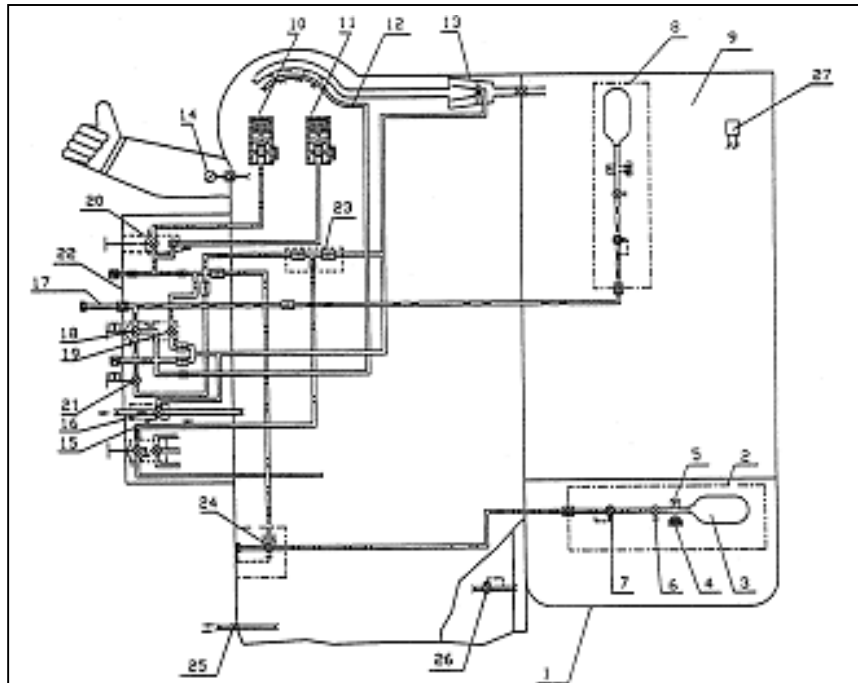

Figure C.1-9. The Orlan Oxygen Supply System. 1 - unpressurized part of the backpack; 2 - primary oxygen unit; 3 - oxygen tank; 4 - filling port; 5 - pressure sensor; 6 - valve; 7 - reducing valve; 8 - backup oxygen unit; 9 - pressurized part of backpack; 10, 11 - primary and backup gas medium absolute pressure regulators; 12 - line for emergency oxygen supply to helmet; 13 - injector; 14 - pressure gauge; 15 - pneumatic valve; 16 - differential pressure valve; 17 - emergency hose; 18 - valve for switching on emergency supply; 19 - valve for switching on the oxygen supply to the injector from the primary tank; 20 - valve assembly for switching the oxygen supply from the primary to the backup pressure regulator; 21 - valve for connecting the backup oxygen supply to the primary oxygen loop; 22 - space suit pneumohydro console; 23 - check valve assembly and connection with the loop for the pneumatic control of the switching on of the water supply to the sublimator; 24 - oxygen valve assembly of the integrated communications connector; 25 - safety valve; 26 - bypass valve on backup pressure shell; 27 - space suit gas medium absolute pressure sensor.

While in the airlock, the Item 24 valve assembly allows oxygen to be drawn from an airlock supply in order to save the oxygen in the primary tank. During operation in the autonomous mode, oxygen passes through the Item 24 valve assembly and through the pneumohydro console to the primary absolute pressure regulator (Item 10 in Figure C.1-9).

If the primary pressure regulator fails, the crewmember switches the oxygen supply to the backup regulator (Item 11 in Figure C.1-9) using a lever (Item 20 in Figure C.1-9). Pressure regulators 10 and 11 are completely identical and are aneroid valves adjusted to switch the “small” oxygen supply to the spacesuit when the absolute pressure falls below 40.0 kPa and to switch to higher than normal supply when the absolute pressure falls below 27.0 kPa.

The oxygen supply can be switched to the “injector” (Item 13 in Figure C.1-9) from the primary tank using lever 19. When the lever is in the other position the emergency oxygen supply is fed from the backup tank to the helmet (via line 12) and at the same time this is happening, oxygen is fed into the injector. The backup oxygen source is connected to the primary oxygen loop, using valve 21 in the event that the oxygen supply in the primary tank is exhausted.

Pressure gauge 14 enables the cosmonaut to visually control the gas pressure in the space suit. Safety valve 25 limits differential pressure of the space suit by a value of 41.0 – 47.0 kPa.

Bypass aneroid valves (Item 26 in Figure C.1-9) are installed on the backup pressure shell of each sleeve and on the backup pressure shell of the legs. If a seal failure occurs in the primary pressure shell and the pressure drops in the space between the shells to 31.0 kPa, then the valve closes, and internal pressure of the gas presses the backup shell against the primary shell, and through it to the load-bearing shell. The backup pressure shell then begins performing the same functions as the primary pressure shell.

Ventilation and Gas Medium Recovery System. The ventilation and gas medium recovery system is designed to remove the crewmember's waste products (carbon dioxide, harmful contaminants, moisture) and, together with the thermal control system, maintains the required thermal conditions in the space suit.

Fans inside the suit drive air circulation for the ventilation system. The fans are switched into operation by the crewmember using toggle switches on the space suit control console. The fans draw the heated gas mixture saturated with water vapor, carbon dioxide and other harmful contaminants out of the space suit through a branched system of air ducts and forces it into an absorbent cartridge. In the absorbent cartridge carbon dioxide and other harmful contaminants are removed from the gas mixture. The carbon dioxide is absorbed by hydrated lithium hydroxide. The gas mixture is further heated as a result of the chemical reaction with lithium hydroxide. Next, the gas mixture is sent to the sublimation heat exchanger. In the heat exchanger the gas mixture is cooled, causing the water vapor contained in it to condense. The condensate is carried by the stream of gas to the moisture separator, where the water is absorbed by a hydrophilous capillary/porous material and then separated from the gas through the porous walls of a metallic ceramic sleeve and passes into the sublimation chamber of the heat exchanger. The dried and cooled gas mixture passes to the space suit helmet, after which it is distributed throughout the space suit and the entire cycle is repeated.

A backup fan is provided to increase the system's reliability. If the primary fan fails, the backup fan is automatically switched into operation. If the liquid cooling system fails, both fans can be switched on by the crewmember to increase the flow of circulating gas in order to increase heat extraction, and also to prevent the helmet window from fogging up.

When the power supply system fails, it is not possible to use either the primary or the backup fans since they are supplied with power from a common network. For this emergency situation the "injector" is provided (see discussion in the Oxygen Supply System section, above). At operating pressure, it supports the circulation in the space suit of the gas medium in the system, and also provides an emergency oxygen supply. EVA time with the injector activated depends on the amount of oxygen left in the primary tank at the moment the injector is activated, while the emergency supply is 30 minutes.

Thermal Control System. The Thermal Control System regulates the space suit interior temperature by means of both a passive thermal protection system (the exterior vacuum shield thermal insulation) and by the operation of the space suit's active thermal control system.

The vacuum shield thermal insulation is designed to protect the crewmember from external thermal influx on the side of the space suit that is illuminated by the Sun. Therefore, the heat emitted by the crewmember and by the space suit's ALSS assemblies must be removed by the

active thermal control system. A schematic diagram of the thermal control system is presented in Figure C.1-10.

The active portion of the ALSS consists of a closed liquid coolant (water) circulation loop pumped through the “water-cooling suit” worn by the crewmember. Primary and backup pumps are switched into operation by the crewmember using toggle switches on the spacesuit electronic console. In the event the primary pump fails, the backup pump is switched on automatically.

Circulating water (and gas medium in the ventilation and recovery system) is cooled in the sublimation heat exchanger (Item 8 in Figure C.1-10). The operation of the heat exchanger is based on the sublimation of ice formed in the pores of the metal-ceramic element from water under the effect of a vacuum. The thermal load of the circulation loop is transferred from the heat carrier to the metal-ceramic cylinder, which results in vaporization of the ice, and cooling of the heat carrier. As the water is consumed, the sublimator is fed from the water tank (Item 11 in Figure C.1-10). The tank capacity is 3.6 liters.

Space Suit Electrical Console. The Space Suit Electrical Console (See Figure C.1-11) is designed to provide visual monitoring of oxygen tank pressure and the voltage level in the spacesuit power supply subsystem. It also provides light signaling when critical levels occur in the reserve oxygen supply, when there is no ventilation, and when the spacesuit pressure drops. In addition, it provides light signaling when the injector is activated.

The microamperemeter located on the front panel of the spacesuit’s electrical console is used as an oxygen reserve and power voltage value indicator. Caution and warnings are indicated with a liquid crystal display located on the chest panel front and light-emitting diodes located on the external surface of the space suit pressure helmet visor.

Electroradio Equipment. The Orlan-M space suit electroradio equipment was designed to support the operation of the electric assemblies

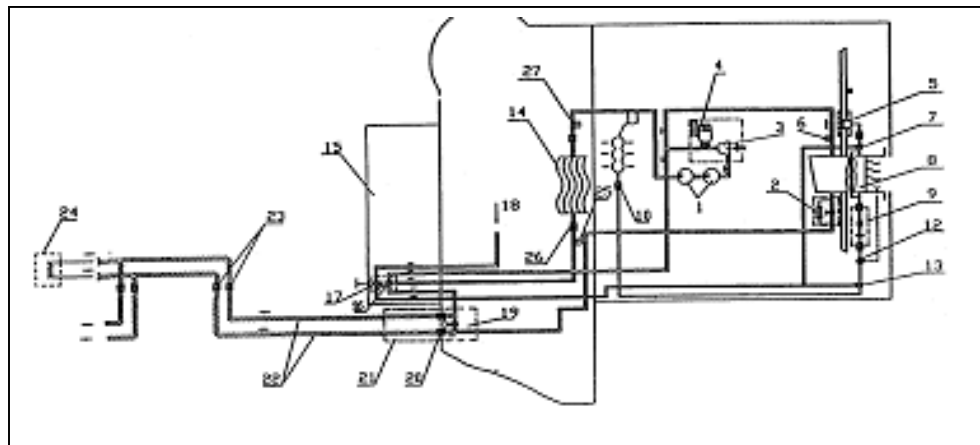

Figure C.1-10. The Orlan Thermal Control System schematic. 1 - primary and backup hydropumps; 2 - water flow rate indicator; 3 - gas bubble separator; 4 - hydroaccumulator; 5 - moisture separator; 6 - water temperature sensor at outlet from heat exchanger; 7 - condensate cut-off valve; 8 - heat exchanger sublimator; 9 - filter with water flow rate limiter; 10 - quick-connect connector; 11 - soft water tank; 12 - reducer; 13 - cut-off valve; 14 - water-cooling suit; 15 - spacesuit pneumohydro console; 16 - T-valve (Using valve 16 the crewmember regulates the level of heat removal maintaining comfortable conditions.); 17 - remote control pneumatic valve for opening/closing shut-off valves 7 and 13; 18 - oxygen supply from oxygen subsystems (see figure 4.3.1-1, item 23); 19 - OPK receptacle; 20 - OPK receptacles' cut-off valves; 21 - OPK on-board receptacle; 22 - water hoses of the airlock interface system hose bundle; 23, 26 - quick-connect connectors; 24 - on-board heat exchanger (not part of the Orlan-M spacesuit set); 25, 27 - water temperature sensor.

of the life support system, radio communications, telemetry control, indication, signaling, and lighting of the work zone.

Electrical power is supplied to the spacesuit from two sources: from a Space Station source through the umbilical or from the autonomous storage battery housed in the spacesuit. Radio communications between the crewmember and the Space Station are carried out over two channels: via umbilical wires, or over the airwaves.

The exterior surface of the space suit, which is covered with a bonded mesh ("radio fabric"), is used as the radio antenna.

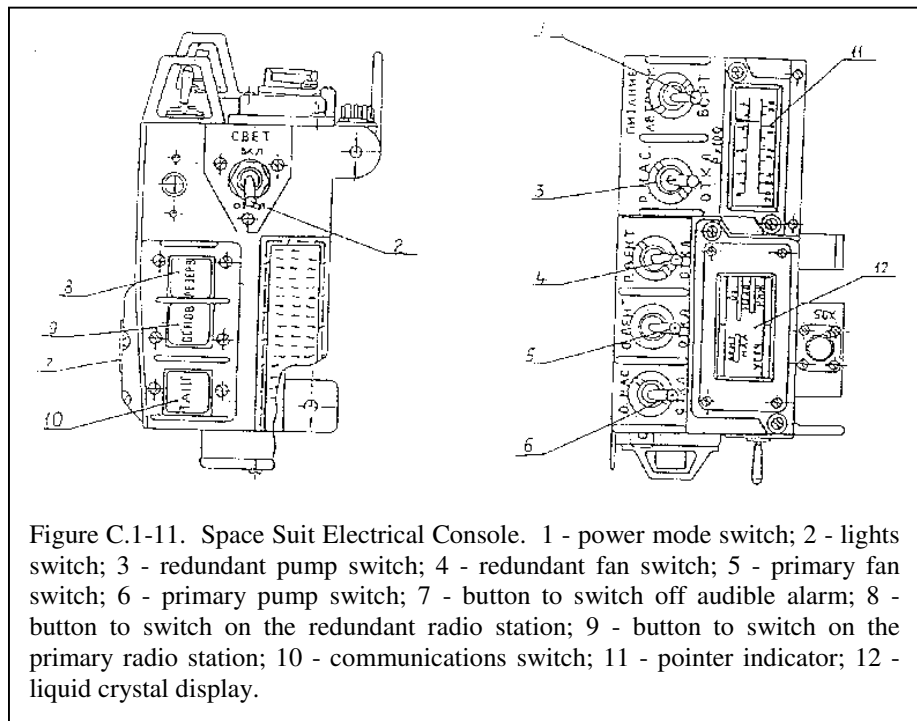

Figure C.1-11. Space Suit Electrical Console. 1 - power mode switch; 2 - lights switch; 3 - redundant pump switch; 4 - redundant fan switch; 5 - primary fan switch; 6 - primary pump switch; 7 - button to switch off audible alarm; 8 - button to switch on the redundant radio station; 9 - button to switch on the primary radio station; 10 - communications switch; 11 - pointer indicator; 12 - liquid crystal display.

Suit Telemetry. The Orlan-M suit telemetry monitoring subsystem is composed of the TRANZIT-A instrumentation. Telemetry information concerning operation of the space suit systems and the crewmember's well-being is transmitted to the Space Station, with subsequent relay to the ground, via two channels: via the umbilical wires or via the airwaves (radio channel). The telemetry information is transmitted over both lines simultaneously during airlock operations and only over the radio channel during EVA.

Seventeen parameters are transmitted via the umbilical wires, three of which are medical parameters. Twenty-six parameters are transmitted via the radio channel, three of which are medical parameters.

With the exception of EKG information, information is sampled from each sensor by the telemetry monitoring system 50 times per second. Information is sampled from the electrocardiogram medical sensor (EKG) 200 times per second. Information is transmitted in real time.

Experimental and Research Garments, Gloves and Life Support Systems. This section discusses experimental EVA garments that are representative of work currently under way to develop a garment that has sufficient mobility for use on planetary surfaces. All of these garments are used to test various concepts for garment components and do not necessarily represent any of the features that will eventually be built into an operational garment. The

following paragraphs do illustrate, however, the range of concepts being considered to meet operational requirements.

The **D-1 (S1035X) space suit** assembly was developed to provide a functional all-soft suit technology demonstrator prototype model that is to be used for mobility system testing and evaluation. The design of the suit was based on the current S1035 Advanced Crew Escape Suit worn by Shuttle crewmembers during launch and re-entry phases of flight, but was upgraded with specific mobility enhancements. The design objective for the D-1 suit was for a predominantly "all-soft" (i.e., fabric) suit system that incorporated minimal bearings and could operate at 25.9 kPa (3.75 psi) pressure. The shoulder joint incorporates a cable-assisted, flat-patterned fabric joint system with an upper arm bearing. The upper arm bearings are the only bearings used in the D-1 suit. The waist/hip joint arrangement is similar in nature to the shoulder joint in the use of a flat-patterned fabric element coupled with a cable-assisted system. The elbow, knee, and ankle joints all utilize fabric, flat-patterned joint elements. The suit incorporates a horizontal, mid-body closure ring for donning and doffing. Additional ancillary items that are representative of an extravehicular suit configuration would be integrated into the D-1 configuration. The current prototype D-1 suit assembly weighs 12 kg (26 lb), exclusive of the ancillary extravehicular items.



Figure C.1-12. The D-1 (S1035X) experimental suit developed by the David-Clark Company.

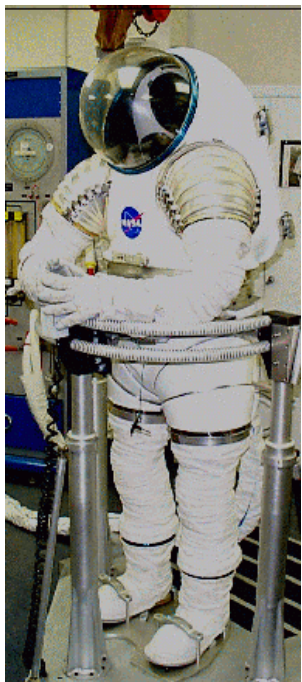

Figure C.1-13. The H-1 or Mark III experimental EVA suit developed from a variety of NASA in-house components.

The **MK III (H-1) space suit** represents a 57.2 kPa (8.3 psi) technology demonstrator model of a zero-prebreathe suit. The basic torso shell, brief, and hip areas of the suit are composed of a graphite/epoxy composite layup. The lower arm and leg/boot areas of the suit are fabric. The suit contains a series of high-mobility joint assemblies in the shoulder, elbow, waist, hip, knee, and ankle areas. The MK III (H-1) suit can incorporate either a 4-bearing joint system or a 2-bearing, rolling convolute joint arrangement that provides multi-axis motion. Single-axis, all-fabric flat-patterned joint systems are utilized for the elbow, knee, and ankle joints. Advantages of the fabric joint elements in the arm and leg areas of the suit include wearer comfort; less-costly, simpler-construction features; and good mobility capabilities. A 3-bearing hip assembly and a single-axis rolling convolute waist joint coupled with a waist-bearing provide excellent torso mobility. Sizing accommodations are provided by quick changeout sizing ring elements utilizing a wire cable attachment and interface method. Donning and doffing of the suit is achieved through a vertical rear-entry closure. Due to the structural nature of the torso shell, a PLSS (i.e., backpack) can be directly mounted or integrated into the basic suit structure. In its present 57.2-kPa (8.3-psi) design configuration, the MK III (H-1) suit weighs 120 lb. However, because future

planetary suits will be designed to operate at 25.9 kPa (3.75 psi), it is felt that the MK III (H-1) suit redesigned weight can be reduced to 36 kg (80 lb) with the incorporation of lightweight structural materials.

The **I-1 space suit** assembly is one of three different configuration baseline advanced SSAs that serve as mobility joint technology test beds for conducting and assessing various test subject pressurized comparative performance task activities. This particular prototype SSA is a configuration that incorporates a limited number of rotary bearing elements in the overall mobility joint system. Bearings are used only in the shoulder, upper arm, and hip areas of the suit configuration. The basic torso area of the suit is fabric as are the joint elements incorporated in the shoulder between the shoulder and upper arm bearings, including the elbows, waist, lower hip area, knees, and ankle joints. The suit is designed for 25.9 kPa (3.75 psi) operating pressure for conducting pressurized mobility studies. The suit assembly provides the necessary interfaces for communications, breathing and ventilation gas supply, and for the test subject worn liquid-cooled garment that removes metabolic generated body heat. The suit incorporates a horizontal, mid-body closure ring for donning and doffing operations. Additional ancillary items that are representative of an extravehicular configured space suit that would be part of the suit ensemble would include the extravehicular visor assembly, the outer layer thermal and micrometeoroid protective cover garment, protective over-boots and gloves. The current prototype I-1 suit assembly weighs 30 kg (65 lb), exclusive of the abovementioned ancillary hardware items.



Figure C.1-14. The I-1 experimental EVA suit developed by the ILC Corporation.

A study was conducted to develop a **new PLSS packaging** concept that would be capable of being maintained by the crewmember, adaptable to technological changes, minimizes weight, and reduces volume. These are all features that are highly desirable as mission durations become very long and as planetary surface operations become another venue for EVA.

Three unique PLSS packaging concepts evolved that could satisfy design requirements. These packaging concepts were subsequently developed into high-fidelity, volumetric mock-ups through the use of sketches, CAD, and modular components. The packaged envelope was restricted to be worn as an on-back system, limiting hardware to what could be carried on a space suit, rather than what could be carried in a support “pull-along” wagon, or other off-body location. Independent teams

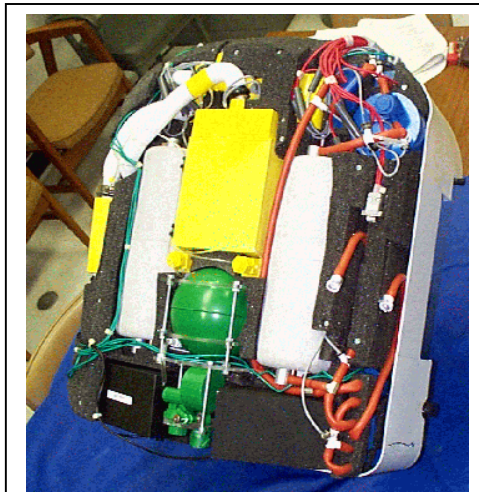

Figure C.1-15. “Foam” advanced PLSS concept.

were assigned to each of the three fundamental concepts for development of full-scale mock-ups of the packaging concept for a comparative evaluation.

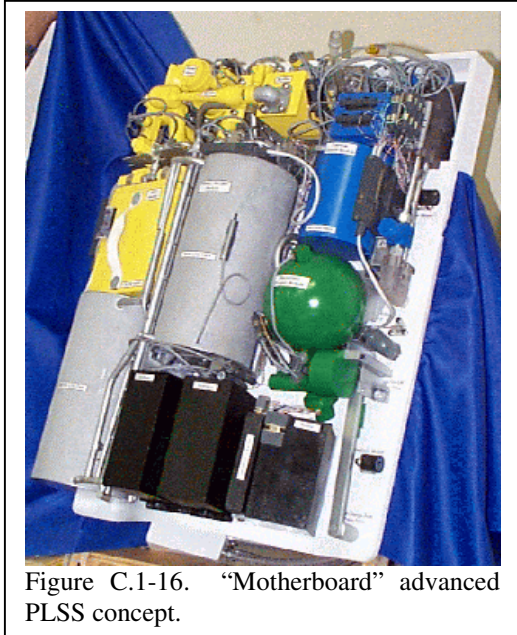

Figure C.1-16. "Motherboard" advanced PLSS concept.

To permit an "apples to apples" comparison of concept weight, volume, and center of gravity aspects, all three teams packaged the same components using the same baseline component schematic design configuration. In addition, the same target radiator area was required of all designs. To demonstrate operational flexibility, each of the groups were required to consider a 4-hour system baseline, with the capability to extend to 8 hours.

The three selected packaging concept configurations, the Foam, Motherboard, and LEGO™ concepts, share many similarities, yet are unmistakably unique. The **Foam** concept (see Figure C.1-15) packages all components in a clamshell rigid chamber with stabilization and protection of individual components provided by a foam material medium. The **Motherboard** design (see Figure C.1-16) attaches

groups of components (modules) to a single mounting plane containing primary module-to-module resource transfer lines. The **LEGO™** package (see Figure C.1-17) links together functionally unique, independently packaged subsystems into a complete operational assembly.

Similarities among the packing concepts include routing of resources from the PLSS into the pressurized suit through a space suit helmet neck ring wedge, using a rigid radiator to protect the PLSS against impact loads, and attaching the PLSS to the suit through two key primary suit mounting structures.

All concepts targeted maintainability by addressing access and handling of components or modules. Design flexibility surfaced in the ability to rearrange and replace items. Weight and volume were reduced in all designs through use of advanced materials, sharing of functions, and effective component configuration. Refer to Table C.1-1 for a summary and comparison of key features of each concept.

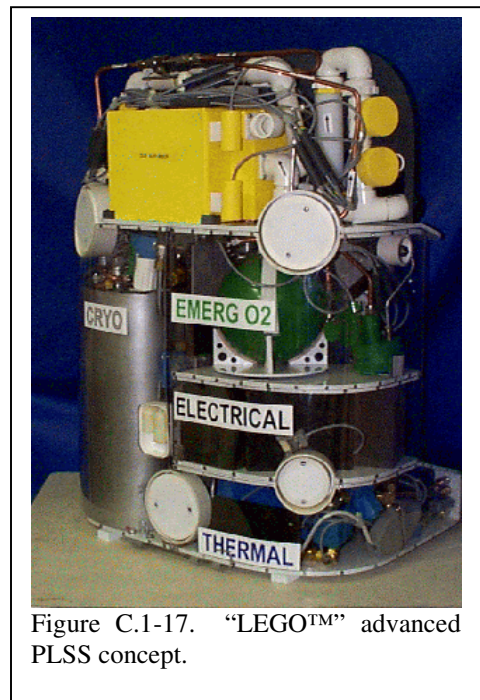

Figure C.1-17. "LEGO™" advanced PLSS concept.

Table C.1-1. A comparison of fey features of three advanced PLSS packaging concepts

| Feature | Foam | Motherboard | LEGO™ |
|--|--|---|---|
| Mass Properties | <ul style="list-style-type: none"> • Weight = 55 Kg (121 lb) • Volume = 68536 cm³ (2.42 ft³) | <ul style="list-style-type: none"> • Weight = 64 Kg (141 lb) • Volume = 91759 cm³ (3.24 ft³) | <ul style="list-style-type: none"> • Weight = 59 Kg (130 lb) • Volume = 74200 cm³ (2.62 ft³) |
| LRU Level | <ul style="list-style-type: none"> • Component | <ul style="list-style-type: none"> • Component/ Module | <ul style="list-style-type: none"> • Module |
| Robustness (Impact, vibration, load path, routine wear & tear) | <ul style="list-style-type: none"> • Triple Protection: Rigid radiator, compliant mounts, foam packing • Aluminum frame • Zero moment pivot | <ul style="list-style-type: none"> • Dual Protection: Rigid radiator, compliant mounts • Slotted waist connection • Bracketed components | <ul style="list-style-type: none"> • Triple Protection: Rigid radiator, foam strips, modular structure • Rail spine attachment • Dual waist catch • Velcro attachment of components |
| Maintenance (Access, leak repair, verification, speed) | <ul style="list-style-type: none"> • Remove radiator for front access, remove back shell for back access • Handling difficult, resource lines intertwined • Leaks disguised, clean-up difficult • Verification at system level • Uncontrolled geometry requires caution in handling | <ul style="list-style-type: none"> • Remove rigid radiator for access to modules & components • Leaks easily seen • Verification at both system & module level • Single plane access for module removal; five-sided access for component removal • Fastener level maintenance possible | <ul style="list-style-type: none"> • Rotate radiator down for module access. Remove module walls for component access • Modules accessible & safely handled • Leaks hidden within module • Verification at both system & module level • No immediate access to internals |
| Design and Construction | <ul style="list-style-type: none"> • Minimum tolerances, fewer parts • Assembled en mass | <ul style="list-style-type: none"> • Modular configuration allows parallel processing • Critical tolerances | <ul style="list-style-type: none"> • Modular configuration allows parallel processing • Questionable access |
| Technology Flexibility (Ability to accommodate design changes) | <ul style="list-style-type: none"> • Layout extremely easy to reconfigure • Open volume allows great freedom of configuration • Minimal interface requirements | <ul style="list-style-type: none"> • Semi-open volume permits freedom of configuration • Area confined to motherboard plane • Existing interface requirements • Changes within module do not impact other systems, changes exceeding module impact entire system | <ul style="list-style-type: none"> • Change limited to module volume • Standard interface consistent link to other modules • Changes within module do not impact other systems, changes exceeding module impact entire system |

(Adapted from O'Connell, et al., 1999.)

C.2 Teleoperated Robotic Devices

Of the elements currently carried under the Human Operated Internal Work System element EVA Functional Breakdown (Element 1.2 as indicated in Figure 3.1-1), only the Teleoperated Robotic Devices have operational or advanced experimental systems. This section will describe the state of the art for these systems, broken into three categories: robotic arms, free-flying inspection

devices, and anthropomorphic robotic system. All of these systems are currently being designed for operations in a microgravity environment.

Although robotic arms constitutes a relatively large category of technology when all of the industrial and laboratory devices are taken into account, the current state of the art for space-based robotic arms that assist in EVAs can be characterized by two devices: the SSRMS, with its Special Purpose Dexterous Manipulator, and the Japanese Experiment Module Remote Manipulator System (JEM RMS).

Free-flying inspection devices are being developed to allow crews to observe EVAs, inspect a location without an EVA, or view locations not visible by an EVA crewmember or other system camera. The Autonomous EVA Robotic Camera (AERCam) is a representative example of this class of systems.

Robotic assistant systems are devices with roughly human proportions and similar functional capabilities. These devices are intended to work side by side with humans, or to go where the risks are too great for people. There are no operational systems of this type currently deployed. However, there are several experimental systems in development that will eventually lead to this operational capability. Three representative examples of this class of system include the EVA Robotic Assistant (ERA), Ranger, and Robonaut.

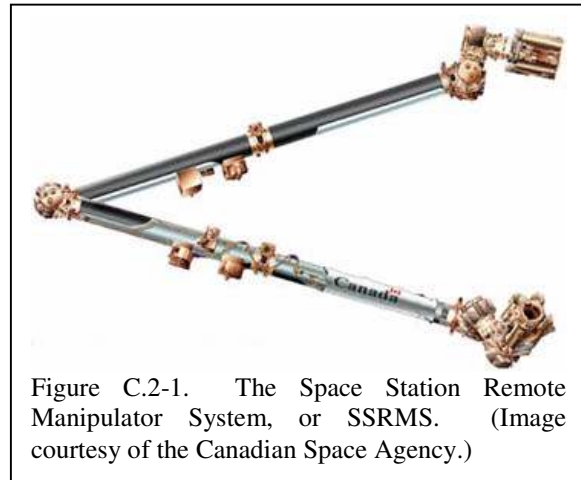

Figure C.2-1. The Space Station Remote Manipulator System, or SSRMS. (Image courtesy of the Canadian Space Agency.)



Figure C.2-2. A general view of the Mobile Servicing System, including the Mobile Base System and the Special Purpose Dexterous Manipulator. (Image courtesy of the Canadian Space Agency)

Each of these devices will be discussed in more detail in the following sections.

Robotic Arms. Robotic arms designed for use in the space environment and to assist with EVAs have been in operation since 1981 when the Canadian-designed and -built RMS flew aboard the Space Shuttle *Columbia*. A progression of more advanced arms and manipulators has followed from this first example.

Space Station Mobile Servicing System. The Space Station Mobile Servicing System, a contribution by the Canadian Space Agency to the ISS, plays a key role in Space Station assembly and maintenance: moving equipment and supplies around the Station, supporting astronauts working in space, and servicing

instruments and other payloads attached to the Space Station. The Mobile Servicing System has three parts:

Canadarm2. Launched on STS-100 in April 2001, the next-generation Canadarm (also known as the SSRMS; see Figure C.2-1) is a bigger, more capable version of the Space Shuttle's RMS. It is 17.6 m (57.7 ft) long when fully extended and has seven motorized joints. This arm is capable of handling large payloads and assisting with docking the Space Shuttle. The SSRMS is self-relocatable with a Latching End Effector, so it can be attached to complementary ports spread throughout the Station's exterior surfaces.

Mobile Base System. A work platform that moves along rails covering the length of the space station, the Mobile Base System provides lateral mobility for the Canadarm2 by traversing the main trusses of the Space Station. (See Figure C.2-2.)

Special Purpose Dexterous Manipulator. The Special Purpose Dexterous Manipulator, or Canada Hand, is a smaller, two-armed robot capable of handling the delicate assembly tasks currently handled by astronauts during space walks. (See Figure C.2-2.)

The general characteristics and capabilities of the Mobile Servicing System are summarized in Table C.2-1.

Table C.2-1. Characteristics and capabilities of the Mobile Servicing System

| Technical Detail | Remote Manipulator System | Dexterous Manipulator | Base System |
|---------------------------------------|----------------------------------|--------------------------------|---|
| Arm Length | 17.6 m (57.7 ft) | 3.5 m (11.48 ft) linear stroke | 5.7 m x 4.5 m x 2.9 m (18.7 ft x 14.76 ft x 9.5 ft) |
| Mass (approx.) | 1,800 kg (3,968 lb) | 1,662 kg (3,664 lb) | 1,450 kg (3,196.7 lb) |
| Mass Handling/Transportation Capacity | 116,000 kg (255,736 lb) | 600 kg (1,322.77 lb) | 20,900 kg (46,076.61 lb) |
| Degrees of Freedom | 7 | 15 | Fixed |
| Peak Power (operational) | 2,000 W | 2,000 W | 825 W |
| Avg. Power (keep alive) | 435 W | 600 W | 365 W |
| Applied Tip Load Range | 0-1,000 N | 0-111 N | N/A |
| Stopping Distance (under max. load) | 0.6 m (1.96 ft) | 0.15 m (5.9 in.) | N/A |

(Adapted from <http://spaceflight.nasa.gov/station/assembly/elements/mss/>; accessed on April 21, 2003.)

JEM Remote Manipulator System. Japan is participating in the ISS project with the JEM called "Kibo." This module is composed of the Pressurized Module, where astronauts can conduct experiments in a one-atmosphere environment, and the Exposed Facility, where experiments can be conducted in an environment exposed to space. The JEM RMS is Japan's first robot arm for actual application. This arm will be able to replace human EVAs for supporting experiments on the Exposed Facility. All of these various elements are illustrated in Figure C.2-3.

JEM RMS is composed of three subsystems, the Main Arm, the Small Fine Arm, and the JEM RMS Console. The 10-m Main Arm is used to exchange payloads (i.e. experiment equipment) on the Exposed Facility. It has a maximum capacity of 7 tons. The 1.5-m Small Fine Arm can exchange equipment weighing up to 300 kg and perform tasks requiring dexterity such as tightening bolts. The Small Fine Arm is mounted at the end of the Main Arm. Astronauts inside Kibo can operate these two arms by remote control from the JEM RMS Console.

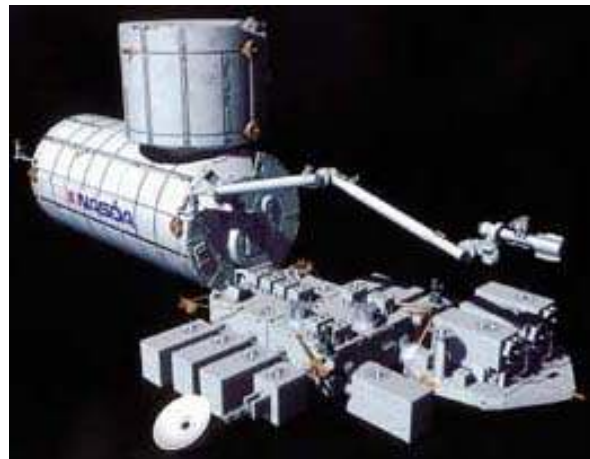

Figure C.2-3. The Japanese Experiment Module with its associated Exposed Facility and Remote Manipulator System. (Image courtesy of NASDA)

(Copied from http://jem.tksc.nasda.go.jp/iss/kibo/develop_status_16_e.html; accessed on April 21, 2003.)

Free-Flying Inspection Devices. The utility of a remotely operated, mobile camera system has been found to be advantageous in several hostile (to humans) environments. Those who perform construction, maintenance and repair in the subsea environment have long used remotely operated camera for site inspection or problem determination in advance of sending humans or other robotic vehicles carry out tasks at a particular site. These vehicles are also used during a task, providing an overview or at least a different view of the worksite and task activities to support crews on the surface.

Similar needs have been identified in the space environment. Adequate views that allow Orbiter IVA crews to observe EVAs, inspect a location without an EVA, or view locations not visible by an EVA crewmember or remote manipulator system camera can be difficult if not impossible to obtain. The ISS camera views are even more restricted due to the much larger structure to be viewed. A camera that has the capability to be positioned without major impact to the design of the Orbiter or ISS could prove to be extremely useful to obtain these views. One potential solution to address this need is the AERCam concept, one example of which was developed and flight tested on a Shuttle mission to demonstrate the feasibility and capability of such a system.

The first of these AERCam vehicles, AERCam Sprint, is a 33-cm (13-in.)-diameter, 16-kg (35-lb)-sphere that contains two television cameras, an avionics system and 12 small nitrogen gas-powered thrusters. Two miniature color television cameras are mounted on the free-flyer, one with a 6-millimeter lens and another with a 12-millimeter lens. The exterior of the free-flyer sphere is covered with a 1.5-cm (0.6-in.)-thick layer of Nomex felt to cushion any inadvertent



Figure C.2-4. AERCam Sprint during its orbital flight demonstration on STS-87. (NASA image STS087-752-035)

contact with a spacecraft surface and prevent damage. The free-flyer is powered by lithium batteries. Its electrical supply and nitrogen supply are designed to last at least 7 hours, the maximum length of a normal space walk. The AERCam sphere has a small floodlight built in that is identical to floodlights used on the helmets of spacesuits. Spaced equally around the sphere also are six small, flashing yellow light-emitting diode lights that make the free-flyer visible to the operator in darkness. The front of the sphere is marked by stripes and arrows while the back is marked by dots. These markings assist the operator in determining the orientation of the AERCam. A small fabric strap on the sphere serves as a handhold for the EVA crewmember while deploying and retrieving the free flyer.

Most of the free-flyer's systems are derived from the development of the SAFER backpack. The AERCam's thrusters, basic avionics, solid-state rate sensors, attitude hold electronics, nitrogen tank and hand controller are identical to those used on the SAFER.

The AERCam is designed to fly very slowly at a rate of less than 7.5 cm/sec (0.25 ft/sec). It also has an automatic attitude hold capability. Remote control of the AERCam is performed through two-way Ultra-High-Frequency radio communications, with data regarding the status of the free-flyer's systems transmitted back to the operator. Television images are transmitted back to the operator via a one-way S-band communications link.

An orbital flight demonstration of the AERCam Sprint was carried out during the STS-87 space walk, where it was released by Mission Specialist Winston Scott and flew freely in the forward cargo bay for about 30 minutes. Pilot Steve Lindsey remotely controlled the free-flyer from the Shuttle's aft flight deck using a hand controller, two laptop computers, and a window-mounted antenna. During the experiment operations, live television images were also relayed via the Shuttle to Mission Control.

Future AERCams, such as Mini-AERCam (see Figure C.2-5), will build on AERCam Sprint technology by adding additional capabilities and more autonomy. The nanosatellite-class spherical Mini AERCam free flyer is 19 cm (7.5 in.) in diameter and weighs approximately 4.5 kg (approximately 10 lb).

Mini AERCam hosts a full suite of miniaturized avionics, instrumentation, communications, navigation, video, power, and propulsion subsystems, including two video imagers and one higher-resolution still-frame imager. Technology innovations include a rechargeable xenon gas

propulsion, rechargeable lithium ion battery, custom avionics based on the PowerPC 740 microprocessor, "camera-on-a-chip" CMOS imagers with wavelet video compression, microelectromechanical system gyros, GPS relative navigation, digital radio frequency communications, micropatch antennas, digital instrumentation network, and compact mechanical packaging.

The Mini AERCam vehicle is designed for either remotely piloted operations or supervised autonomous operations including automatic station keeping, point-to-point maneuvering, and automated docking approaches. Free-flyer ground-based testing has been conducted on an air-bearing table and in a six degree-of-freedom closed-loop orbital simulation.

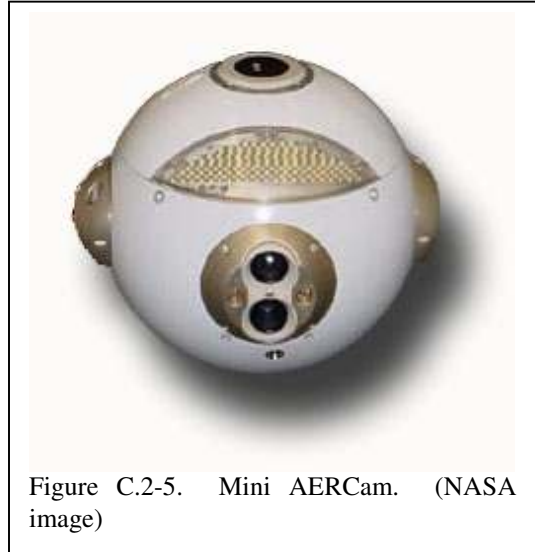

Figure C.2-5. Mini AERCam. (NASA image)

(Adapted from <http://spaceflight.nasa.gov/station/assembly/sprint/>, accessed on March 15, 2003, and from <http://aercam.nasa.gov/index.htm>, accessed on April 28, 2003.)

Robotic Assistant Systems. Experience gained during both Apollo missions and the many assembly, servicing, and maintenance EVAs conducted from the Space Shuttle has indicated the desirability of varying degrees of assistance that could be reasonably supplied by robotic devices. IVA astronauts using the Shuttle RMS have provided this kind of support for Shuttle missions, with increasingly expanded roles for this portion of an EVA. This section describes three experimental systems that illustrate the potential range of robotic support that could be supplied during future EVAs, ranging from the relatively simple task of transporting large and/or heavy objects for the EVA crew (the ERA) to relatively sophisticated tasks requiring a high degree of mobility and dexterity (Ranger and Robonaut).

The *Extravehicular Activity Robotic Assistant* is a wheeled robot (see Figure C.2-6) that is being used as a test bed for research into the requirements for successful collaboration between suited astronauts and autonomous robots. Despite the strong interest in factoring robotics into human exploration plans, relatively little research has been conducted on the use of robotics in conjunction with EVA crewmembers conducting surface tasks, or on the integration of information technology systems into the suit system. Indeed, the first field test of astronaut/rover interaction was the Astronaut Rover Interaction Field Experiment conducted in 1999.



Figure C.2-6. The ERA in a field exercise with a test subject wearing the Mark III experimental EVA garment. (NASA photo)

Development of robotic assistants for astronauts is motivated by two primary concerns:

- 1) Astronaut time is a valuable resource. Any assistance that can offload routine or repetitive tasks will free up the astronauts to focus their expertise where it is most needed. Robots can perform simple inspection and maintenance tasks, as well as scout terrain, build maps, and gather field samples.
- 2) The space environment is extremely hazardous. The spacesuits that enable people to work in and explore this environment also impose severe constraints on mobility, dexterity, communication, visibility, and strength. Robots can enhance astronaut capabilities in these areas, creating a human/robot team that can accomplish tasks that neither one could do alone.

The ERA in its current configuration is equipped with many sensors, including GPS, stereo vision for obstacle avoidance and path planning/navigation, stereo vision for astronaut tracking, laser scanning range-finder, 6-axis accelerometer, compass, and inclinometers. It also has many ways to interact with its environment: 6-degree-of-freedom manipulator, pan-tilt-vergence active camera platform, and drive platform that can handle rugged terrain while carrying tools, samples, and equipment and pulling a trailer. The processing is all done on-board on four PC/104 Pentium II computers using the Linux operating system, and using the CORBA standard for inter-process communication.

(Adapted from http://vesuvius.jsc.nasa.gov/er_er/html/era/ERA_Home_Page.html; accessed on April 22, 2003.)

For a number of years, research has been under way to investigate the use of more sophisticated robotic systems that could complement and eventually take over EVA tasks currently performed by humans. Two examples illustrate the diversity of the research in this area: Ranger and Robonaut.

Ranger (University of Maryland Space Systems Laboratory) was originally designed as a low-cost means of moving telerobotics experiments beyond the laboratory to actual spaceflight experience. It has evolved into a family of similar but specialized robotic systems. In one experiment, the Ranger Telerobotic Shuttle Experiment was intended to demonstrate telerobotic servicing on International Space Station ORUs and EVA equipment in the Space Shuttle cargo bay. The Ranger Telerobotic Shuttle Experiment was designed as a four-manipulator telerobot with one permanently attached to a Spacelab pallet (see Figure C.2-7). The manipulators would perform dexterous manipulation, body repositioning, and stereo video viewing. This experiment has yet to fly, but neutral buoyancy tests have been conducted of the tasks to be performed.

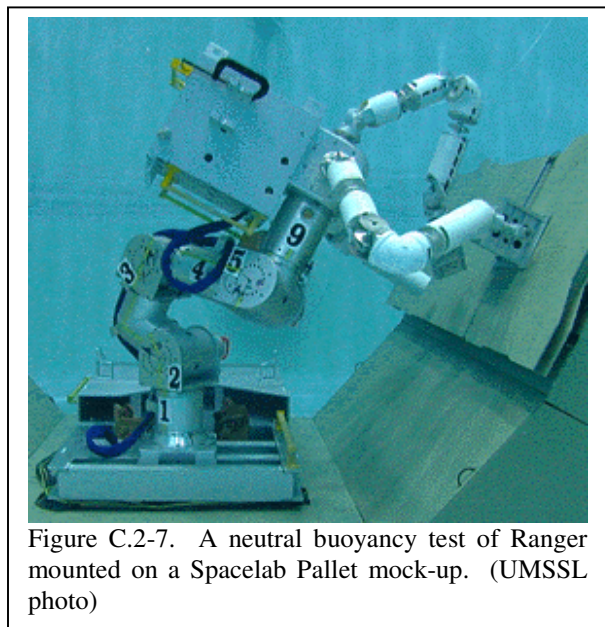

Figure C.2-7. A neutral buoyancy test of Ranger mounted on a Spacelab Pallet mock-up. (UMSSL photo)

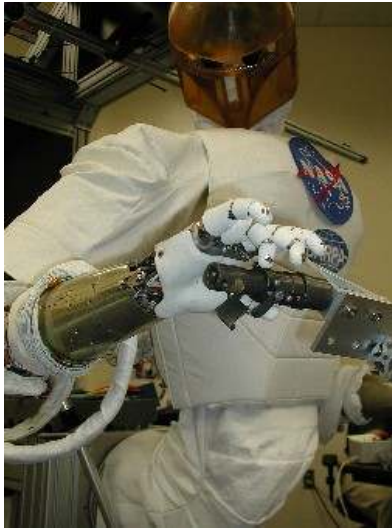

Figure C.2-8. The Robonaut system. (NASA photo)

Robonaut is a humanoid robot designed by the Robot Systems Technology Branch at JSC in a collaborative effort with DARPA. The Robonaut project seeks to develop and demonstrate a robotic system that can function as an EVA astronaut equivalent. While the depth and breadth of human performance is beyond the current state of the art in robotics, NASA targeted the reduced dexterity and performance of a suited astronaut as Robonaut's design goals, specifically using the work envelope, ranges of motion, strength and endurance capabilities of space-walking humans.

The Robonaut concept (see Figure C.2-8) consists of two 7-degree-of-freedom arms, two 12 degree-of-freedom multi-finger robotic hands, a 6+ degree-of-freedom "stinger tail," and a 2+ degree-of-freedom stereo camera platform. The robotic arms are capable of dexterous, human-like maneuvers, and are designed to ensure safety and mission success. The robotic hands are designed to handle common

EVA tools, to grasp irregularly shaped objects, and to handle a wide spectrum of tasks requiring human-like dexterity. For stabilization, the Robonaut will have a "stinger tail" that can plug into WIF sockets located around the ISS. The Robonaut will be teleoperated by an IVA crewmember using telepresence equipment, such as a head-mounted display, tracker sensors, virtual reality gloves, or force-reflective arm and hand masters. The stereo camera platform will provide stereo video images to the human operator and to the on-board vision system.

A key component of the overall Robonaut concept is the integrated dexterous arm-hand module. The dexterous hand will have four fingers and a thumb in a human hand-like arrangement. The thumb, index, and middle fingers will each have three independent degrees of freedom. The ring and little fingers will each have one degree of freedom. The dexterous hand will also have a palm degree of freedom that allows the palm to arc (as viewed from the end of the fingers). Extensive human hand kinematics analysis has revealed that the palm degree of freedom is essential for grasping and using hand tools. The hand will be driven by twelve miniature brushless motors tightly packaged in the forearm. The forearm will also house two motors that drive the wrist P-Y degree of freedom. As a safety measure, the hand will be non-backdriveable to eliminate any chance of inadvertent release. For fault recovery, an EVA crewmember can release the robotic hand through one-handed manual backdrive mechanism. The fingers will also have a compliance feature to minimize the impact force stemming from inadvertent contact with the surrounding structures.

(Adapted from http://ranier.hq.nasa.gov/telerobotics_page/FY97Plan/Chap2g.html#Robonaut; accessed on Apr 24, 2003.)

C.3 Transportation

Currently, EVA activities are carried out exclusively in a free-space microgravity environment. As such, the current state of the art for EVA transportation systems are designed to operate only in this environment. Because of this focus on microgravity operations, the current state of the art

for planetary surface transportation remains the systems developed for the Apollo program, which were discussed previously (see Appendix B)

The Transportation System element of the EVA Functional Breakdown (Element 1.3 as indicated in Figure 3.1-2) includes both pressurized and unpressurized systems. A subset of the pressurized systems is the airlock, which would be necessary for suited EVA personnel to exit the vehicle. Thus this section will discuss both mobility systems for EVA

crew as well as airlocks. There are currently two free-space EVA mobility systems in operational use: the SAFER and the Crew and Equipment Translation Aid (CETA) cart. There are also two airlocks in operational use: the Shuttle airlock (discussed previously in Appendix B.4) and the Joint Airlock Module (JAM) used on the ISS. This section will discuss SAFER, CETA, and JAM in more detail; the reader is referred to Appendix B.4 for information on the Shuttle airlock system.

Simplified Aid for Extravehicular Activity Rescue. SAFER is a self-rescue device for use on EVAs conducted at the ISS. In the unlikely event that an astronaut became separated from the station during an EVA the crewmember would use the propulsive power of SAFER to return to the Station structure. But this is a rescue unit only—it is not designed for sustained or routine operation in the free-space environment.

SAFER fits over the PLSS of the Shuttle EMU as illustrated in Figure C.3-1. The device weighs 37.7 kg (83 lb), more than 114 kg (250 lb), lighter than the MMU. SAFER attaches to the astronaut using the six existing PLSS hard points, including the two provided for the MMU, so no EMU modifications were required. A control module consisting of a joystick and display is embedded in one of the thruster “towers.” When needed, the astronaut pulls a lanyard so the controller swings out on an arm, placing it within easy reach. With this control interface the astronaut can maneuver using nitrogen gas released through 24 nozzles that are fixed in different orientations around the SAFER system. An autopilot system is also available to keep the astronaut at the same orientation for a limited period. SAFER features the same maneuverability as the MMU but because its nitrogen tank only holds 1.4 kg of nitrogen gas, the total velocity change possible with the unit is 3.05 m per second.

A SAFER unit has also been developed to operate with the Orlan-M space suit. This system provides the same functional capabilities as the EMU-based system but with appropriate interfaces and attachments for the Orlan suit.

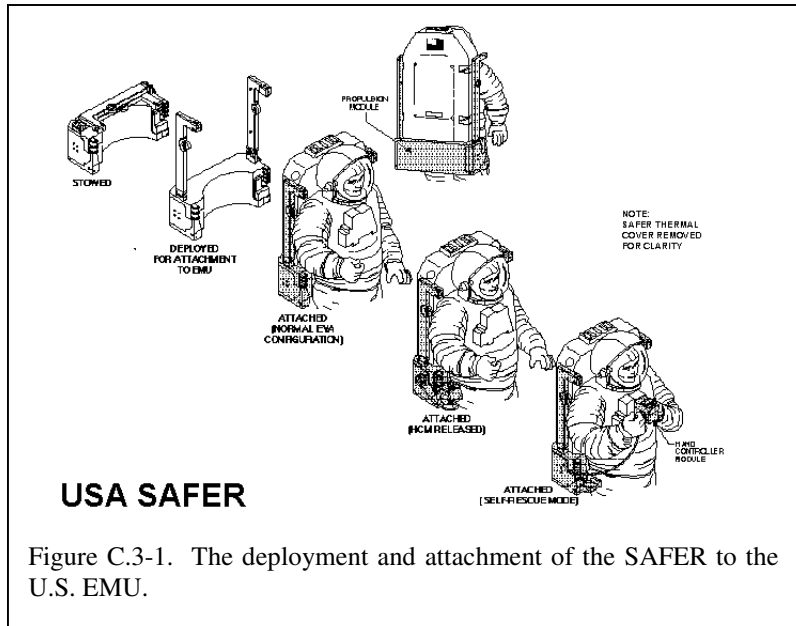

USA SAFER
Figure C.3-1. The deployment and attachment of the SAFER to the U.S. EMU.

(Adapted from <http://quest.arc.nasa.gov/space/teachers/suited/6work.html>; accessed on Jan 23, 2003 and from Portree and Trevino, 1997.)

Crew and Equipment Translation Aid cart. The CETA cart provides assistance for translation of crew, ORUs, and EVA equipment along the ISS truss structure and serves as a work platform for maintenance actions conducted on the truss and mobile service station. There are two CETA carts on the ISS.

The CETA cart was designed to be a manually operated transportation device that moved along rails placed on the truss structure for the Mobile Transporter (the device used to move the ISS remote manipulator along the truss). On orbit, the two CETA carts will be located one on each side of the Mobile Transporter for usage flexibility. If required, a cart may be moved to the other side of the Mobile Transporter to complement the other cart. These carts can also be used independent of the Mobile Transporter, in which case the crew operates them manually.

The CETA has attachment points for other EVA hardware such as the ORU Transfer Device, also known as the Space Crane; Articulating Portable Foot Restraint; EVA Tool Stowage Device, and other EVA tools.

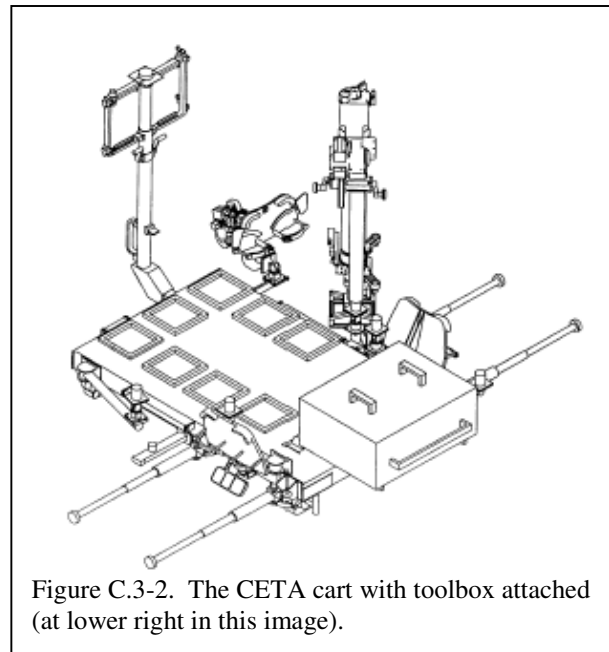

Figure C.3-2. The CETA cart with toolbox attached (at lower right in this image).

Key data for the CETA cart are as follows:

Size: 250 cm x 235 cm x 90 cm (99 in. x 93 in. x 35 in.)

Mass: 283 kg (623 lb)

Volume: 13.3 m³ (468.48 ft³)

In addition to the CETA cart, a toolbox was designed to provide central stowage locations for high-use EVA tools. Each CETA cart carries one of these toolboxes. This toolbox has a mass of 74 kg (126 lb). The toolboxes will be located on the Z1 truss before installation on the CETA carts.

(Adapted from the NASA STS 112 and STS 113 Press Kits.)

Joint Airlock Module. The JAM is one of the major elements of the ISS and provides the ISS crew with an independent means of performing EVAs. A key feature of the JAM is that it won't discriminate among space suits. In the Space Shuttle's airlock the power/communications system and connections for oxygen and coolant will not interface with Russian suits; conversely, U.S. suits will not fit through Russian-designed airlock hatches. The JAM, however, will allow station-based EVAs with either U.S. or Russian space suits.

The Joint Airlock is divided into two compartments: the Equipment Lock and the Crew Lock.

The Equipment Lock is the primary area where the crewmembers don and doff their space suits. It is also the primary area for servicing the space suits and for stowing them. The Equipment Lock is typically open to the interior of the ISS and thus maintains the same ambient pressure. In preparation for an EVA, crews will don their space suits in the Equipment Lock and ambient pressure is gradually lowered to 703 mbar (10.2 psi).

The Crew Lock, which is separated from the Equipment Lock by a hatch, is where crew open the outer hatch and actually begin their excursions into space. After a final leak check by the EVA crew, the remaining air in the Crew Lock (about 345 mbar or 5 psi) is vented overboard through a valve on the outer hatch. The Crew Lock was built as small as possible to minimize the amount of air lost from the ISS to space during this venting process; the Crew Lock actually loses less air to space than the Shuttle airlock.

Key data for the JAM are as follows:

- Material: Aluminum
- Length: 5.5 m (18 ft)
- Diameter: 4 m (13 ft)
- Weight: 6,064 kg (13,368 lb.)
- Volume: 34 m³ (1,200 cu ft)

(Adapted from the NASA STS 104 Press Kit and from http://science.nasa.gov/headlines/y2001/ast06jul_1.htm; Accessed on Jan 27, 2003.)

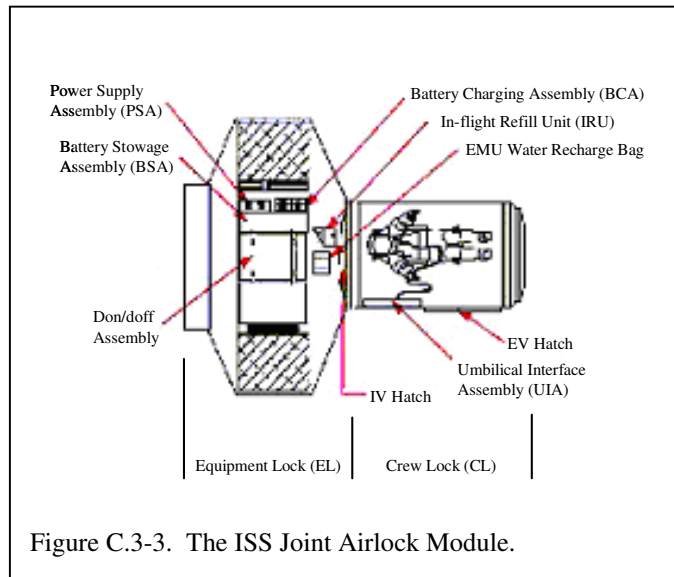

Figure C.3-3. The ISS Joint Airlock Module.

C.4 Support Systems

The Ground-Based Support Systems (Earth) element of the EVA Functional Breakdown (Element 1.5 as indicated in Figure 3.1-2) includes facilities used to develop and test EVA systems, with subsequent training of personnel who will use them, and those facilities used to support these systems after they are deployed in an operational environment. As with many systems used for EVA, this element of the Functional Breakdown is a combination of upgrades to existing systems and new systems using technology that did not exist before or that could not be incorporated into previous designs.

State-of-the-art reduced-gravity facilities have retained the same functional capabilities described previously but have incorporated contemporary subsystems (e.g., computer-driven control systems, sensors, and data collection devices) and, in some cases, expanded capacity or functionality. For example, new counterbalance systems are being deployed with increased capability and flexibility; neutral buoyancy facilities have increased in number and expanded their capabilities; upgraded aircraft are being used for parabolic flight (NASA has retired one Boeing KC-135A and replaced it with another KC-135 airframe with fewer flight hours and upgraded systems).

One-g EVA test support facilities have incorporated advances in computing hardware and software, adding “virtual reality” simulation to the traditional environmental chambers that are still in use. In addition, higher-fidelity mock-ups of representative EVA systems are being constructed to test both hardware and operations concepts.

Analog Earth-based terrain sites, representative of planetary surface features, are still an important element for both testing and training. Because of their representative geologic features, many of the sites used during Apollo are still used today. New sites that are representative of the Martian environment are also being added.

Finally, mission support facilities have kept pace with advancing hardware and software technology but with relatively little change in functionality. In addition, ground facilities are being used to test new or expanded approaches to supporting flight operations from the ground.

The following sections will discuss facilities that are currently in use in the development, test, and operation of the EVA systems described in previous sections.

Reduced-Gravity Facilities. Three different approaches are still being used to simulate or reproduce the reduced-gravity experienced in free space, on the lunar surface, and that will be experienced on the Martian surface: mechanical counterbalances, neutral buoyancy water tanks, and aircraft flying parabolic trajectories. This section discusses representative examples of each of these systems that are in current use.

Mechanical Counterbalance. The mechanical counterbalance remains one of the most cost-effective and versatile tools for the development, testing and training associated with EVAs in a fractional gravity environment, complementing neutral buoyancy facilities for the microgravity environment. The technology for the mechanical portions of these counterbalances has changed little from that used in systems that date to the early phases of the space age. The evolution of digital controls and other electronic systems has helped to make these systems more flexible and responsive to the range of testing for which these devices are used. One of the latest systems in this category is the Partial Gravity Counterbalance System (PGCS) now under development (see Figure C.4-1). The following list of tasks illustrate the diverse range of capabilities being incorporated into this system:

- Conduct representative lunar and Martian gravity tests of advance space suit mobility systems;
- Conduct lunar and Martian gravity shirtsleeve and space suited metabolic studies using the PGCS in combination with a treadmill;
- Conduct space suit and EVA ancillary support equipment studies in a simulated planetary “dust track” environment in order to determine dust and abrasion abatement techniques as well as protective measures;
- Conduct walking dynamic studies and candidate planetary boot design and material evaluations;
- Conduct candidate planetary space suit material durability testing with representative planetary surface simulant material; and

- Conduct representative planetary EVA deployment task activities using the PGCS and in simulated planetary lighting conditions.

Neutral Buoyancy Water Tanks. Neutral buoyancy water tanks continue to be used as a tool for the design, testing, and development of future space systems. These facilities are not only increasing in size to accommodate the larger physical size of space systems, but their numbers are increasing as well, with more organizations becoming actively involved with development and testing of space systems that may require EVA support.

The largest of the currently operating neutral buoyancy water tanks, and representative of the current state of the art for these facilities, is NASA's NBL at JSC (see Figure C.4-2).

The NBL was sized to perform two test activities simultaneously, each using mock-ups sufficiently large to produce meaningful training content and duration. The NBL is 61 m (202 ft) in length, 31 m (102 ft) in width, and 12 m (40 ft) in depth (6 m, or 20 ft, above ground and 6 m below ground). This is sufficiently large to hold a full-scale mock-up of the Shuttle cargo bay plus several ISS modules (most importantly, the Joint Airlock mock-up) and one half of the Station's truss structure. Also included are full-scale working models of the Shuttle and Station

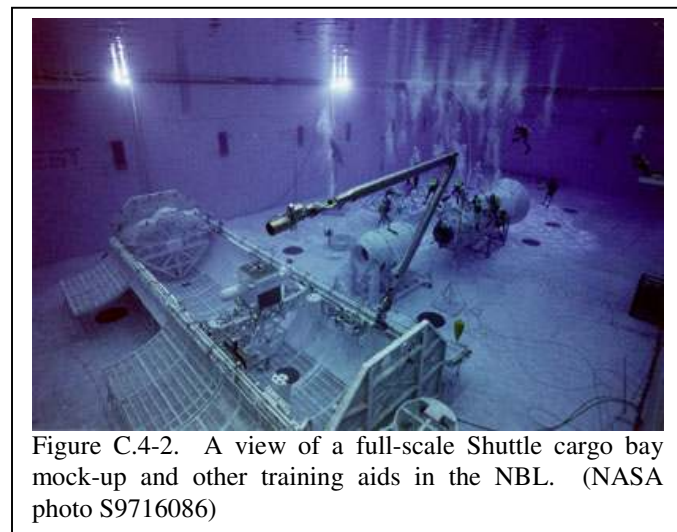
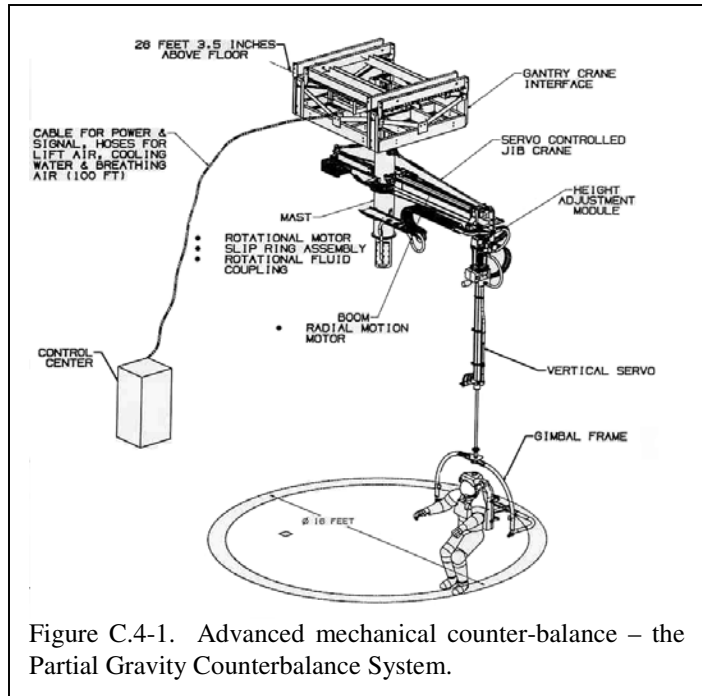

Figure C.4-2. A view of a full-scale Shuttle cargo bay mock-up and other training aids in the NBL. (NASA photo S9716086)

robotic arms. Both models are hydraulically operated to improve durability and minimize safety concerns. Two overhead bridge cranes (each capable of lifting 10 tons) and several jib cranes (each capable of lifting 1.6 tons) around the perimeter of the NBL are used to configure mock-ups for each training session.

The NBL holds almost 23,500 m³ (6.2 million gallons) of water, which is recycled every 19.6 hours. It is automatically monitored and controlled to a temperature of 28° – 31° Celsius (82° –

88° Fahrenheit) to minimize the potential effects of hypothermia on support divers. It is also chemically treated to control contaminant growth while minimizing long-term corrosion effects on training mock-ups and equipment.



A full complement of voice communication systems is available. This includes full two-way communications among the suited astronauts, topside trainers, facility test coordinators, the flight control team within JSC's Mission Control Center, and the remainder of the Shuttle crew (not performing EVA) at the on-site Shuttle Mission Simulator. A series of underwater speakers allows one-way communication to the support divers; an upgrade to this system is under development to support dual run capability. Video coverage of all training activities is accomplished using hard-mounted and handheld cameras. The video is used by the topside trainers and simulation control team and is also transmitted to on-site (JSC) training facilities.



Figure C.4-4. The NASDA neutral buoyancy facility with a full-scale mock-up of the Kibo module destined for the International Space Station. (NASDA photo)

(Adapted from <http://www.jsc.nasa.gov/dx/dx12/htmls/NBLFeatures.htm>; accessed on Feb 13, 2003.)

The Russian Space Agency continues to use their neutral buoyancy facility at Star City (discussed previously) for development and training.

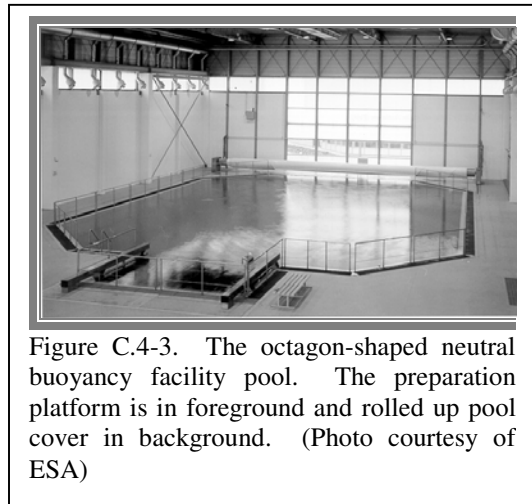

Figure C.4-3. The octagon-shaped neutral buoyancy facility pool. The preparation platform is in foreground and rolled up pool cover in background. (Photo courtesy of ESA)

The European Space Agency (ESA) conducts neutral buoyancy training (see Figure C.4-3), primarily at the European Astronaut Center, located in Cologne, Germany, with support from the Control Centers and various industrial sites and user centers in Europe. The European Astronaut Center neutral buoyancy facility uses an underground reinforced-concrete water tank with a length of 22 m (72 ft), a width of 17 m (56 ft), a depth of 10 m (33 ft), and chamfered corners (4.88 m or 16.0 ft) with a total volume of 3747 m³ (203,200 gallons). Test personnel are housed on the same floor in the Neutral Buoyancy Control Room, where consoles, intercom and video monitors are provided for test monitoring and control. The test

facility has supported EVA training with the Russian Orlan spacesuit in years past. Test data are collected and stored using audio/video tapes.

The Japanese National Space Development Agency (NASDA) has built its own neutral buoyancy facility to support development and training for its ISS module, Kibo. The Weightless Environment Test System, will be used to evaluate EVA procedures, tools and equipment prior to the actual operation. The Weightless Environment Test System tank (See Figure C.4-4) is 16 m (52 ft) in diameter, and 10.5 m (34.4 ft) in depth, sufficiently large to contain a full-scale mock-up of the entire Kibo Pressurized Module and unpressurized Exposed Facility.

(Adapted from http://jem.tksc.nasda.go.jp/ssip/ssip_wet_e.html; accessed on Feb 13, 2003.)



Figure C.4-5. The deck area of the NBRF. In the tank is a mock-up of a section of the ISS main truss. (UMD photo)

Other institutions have also built and currently operate neutral buoyancy facilities for research, development, and training purposes. One example of this is the Neutral Buoyancy Research Facility (NBRF) at the University of Maryland's Space Systems Laboratory. It is the only one located on a college campus and the only one dedicated to basic research. The tank is 15.2 m (50 ft) in diameter, 7.6 m (25 ft) deep, and holds 1390 m³ (367,000 gallons) of water.

On the second floor of the NBRF is the control room where students and staff members conduct tests in the neutral buoyancy tank. The control room has

several Silicon Graphics computers that are used to control robots underwater through Space Shuttle-style hand controllers or a virtual reality interface. In addition, the control room houses a communications system that allows test conductors to communicate with divers underwater, with personnel throughout the NBRF, and with other sites across the country through the Internet and satellite links. The control room also houses a complete video control and editing suite.

(Adapted from <http://www.ssl.umd.edu/facilities/facilities.html#NBRF>; accessed on May 2, 2003.)

Aircraft Flying Parabolic Trajectories. While any aircraft can fly parabolic trajectories and thus provide a reduced-gravity environment, the state of the art for EVA training and testing remains large fuselage aircraft. NASA continues to use the Boeing KC135 aircraft, although the first of these airframes has been retired and a second one is now in use. Russia continues to use an Ilyushin IL-76, in particular the MDK version. ESA has used both the NASA and Russian aircraft as well as the Aerospatiale Caravelle for previous reduced-gravity simulation flights. ESA has used an Airbus A-300 since 1997. Other organizations, including some commercial companies, use other aircraft such as the Boeing 727 and McDonnell-Douglas DC-9. Figure C.4-6 illustrates the relative sizes of the KC135, IL-76, and the A-300. Table C.4-1 compares some of the pertinent characteristics of these three aircraft.

While both the KC-135 and IL-76 both have large cargo doors through which equipment can be loaded, the A310 is constrained to items that will fit through a passenger door. Also, the A-300 flies a slightly different flight profile from both the KC-135 and IL-76, although this is an operational preference and

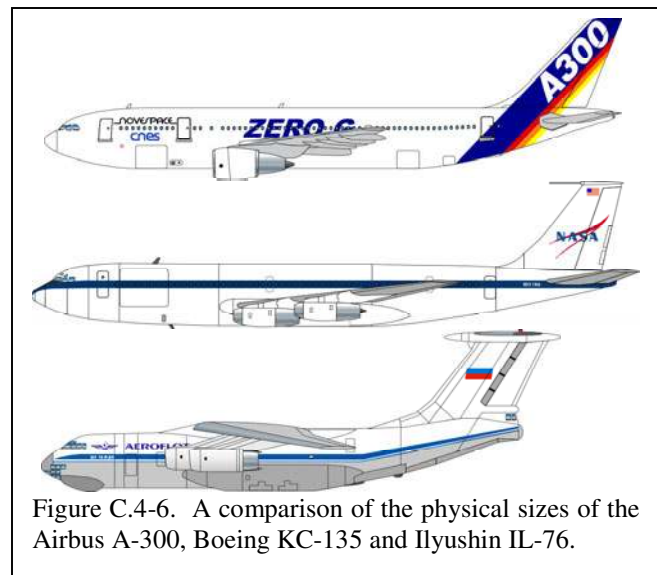

Figure C.4-6. A comparison of the physical sizes of the Airbus A-300, Boeing KC-135 and Ilyushin IL-76.

not a constraint on any of the aircraft. ESA has chosen to fly its parabolas with a period of 3 minutes between the start of two consecutive parabolas, i.e. a 1 minute parabolic phase (20 seconds at 1.8g + 20 seconds of weightlessness + 20 seconds at 1.8g), followed by a 2 minute "rest" period at 1g. After parabolas 10 and 20 however, the rest interval is increased to 6 minutes. This "rest" interval gives researchers time to adjust their experiments.

Table C.4-1. A comparison of aircraft characteristics pertinent to EVA training and tests

| | Boeing KC-135 | Ilyushin IL-76 | Airbus A-300 |
|--|--|--|--|
| Typical number of parabolas per flight | 30 – 40 | 20 | 30 |
| Test area length | 18 m (60 ft) | 14.2 m (46.6 ft) | 20 m (65.6 ft) |
| Test area height | 3.25 m (10 ft) | 3.45 m (11.3 ft) | 2.3 m (7.5 ft) |
| Test area width | 2 m (7 ft) | 3.4 m (11.2 ft) | 5 m (16.4 ft) |
| Electrical power | 110 V AC at 60 Hz 110 V AC at 400 Hz 28 V DC | 220 V AC at 50 Hz 208/115 V AC at 400 Hz 27 V DC | 220 V AC at 50 Hz 115-200 V AC at 400 Hz 28 V DC |

One-G Facilities. This category of the EVA system hierarchy is set aside for environmental chambers and facilities set up to test EVA systems in appropriate environmental conditions other than reduced gravity. Typically this means vacuum and thermal extremes encountered in free space and on planetary surfaces. Many of the environmental chambers described previously remain in use, with upgrades to controls and monitoring systems, making them still the state of the art for this type of facility.

In two areas, the state of the art is changing, due in one case to the introduction of relatively new technology and in the other to the scope and scale of the facility involved. In the first case, virtual reality has become part of the standard set of testing and training aids for EVA operations. In the second case, high-fidelity and long-duration facilities are being developed to accommodate the larger scale and longevity of future planetary missions. Examples of each of these are discussed below.

Virtual reality EVA training has been in use for well over ten years. For U.S. missions, this training has been developed and conducted at the Virtual Reality Laboratory (VRLaboratory), located at JSC. The virtual environment that can be created in this laboratory involves not only EVA crewmembers, but IVA crewmembers operating robotic arms or providing other types of support. Both Shuttle and Space Station EVA missions can be simulated in this environment.



Figure C.4-7. Astronaut Jerry Ross uses virtual reality EVA training in the VRLaboratory as part of the preparation for STS-88. (NASA photo s98-05079)

In the VRLaboratory, an EVA crewmember wears a helmet-mounted display to receive training in an environment generated by computer graphics techniques. The trainee wears gloves and attachments on his or her hands and legs to reflect the detailed movement of hands and legs in the computer graphics image presented in the helmet-mounted display. The VRLaboratory also has workstations set up for the simulated use of either the Shuttle's or the Space Station's robot arm. The ability to simulate both the EVA and IVA activities has been found to be particularly useful in working out the choreography between these two crews in advance of any more detailed training, such as in the NBL, or before conducting the actual EVA. This capability has evolved to the point that ISS crews are being provided with the virtual reality training capability while on orbit and are conducting EVAs based solely on this training capability. To illustrate, on February 20, 2002, the first space walk from the Space Station's Joint Airlock without a Shuttle Orbiter present, was carried out and was rated as highly successful. Its main purpose was to prepare for and increase efficiency of the four EVAs planned for 8A/STS-110, all to be conducted from the JAL, primarily to install the solar array truss segment S0. Flight Engineers Carl Walz (EV1) and Dan Bursch (EV2) trained for this based solely on virtual reality systems. As described by Dan Bursch:

“In January Houston told us that Carl and I would get the opportunity to go outside again, but this time in the U.S. suit, or ‘EMU.’ Many people on the ground worked endless hours preparing us for this walk. Not only did they send up procedures and pictures, but they also sent up special files that we used in a software program called ‘DOUG’ that allowed us to perform our EVA on a laptop. It has the same graphics used in a ‘Virtual Reality Laboratory’ at JSC, where we had trained for EVAs and robotics before launch. We had several weeks to prepare equipment and ourselves for the walk. It was the second time that the U.S. airlock had been used and the first time by a Station crew without the Shuttle present (often called a ‘deferred EVA’). We did a dry-run of the procedures the week before, worked out some kinks, then went out for real a few days later. Yury [Onufrienko] suited us up and then passed over the communication to Joe Tanner who acted as our ‘IVA’ during the walk. Yury was inside controlling cameras, much like I did when he and Carl went out on their EVA mid-January. It was very successful...”

(Copied from <http://spaceflight.nasa.gov/station/crew/exp4/120days.html> Accessed on May 11, 2003)

Their excursion was also the first EVA with an intravehicular crewmember on the ground, not in space. This IVA crewmember was astronaut Joe Tanner. His running guidance of EV1 and EV2 proved instrumental to the success of the EVA.

The use of *high-fidelity and long-duration facilities*, both indoor and outdoor, for testing EVA systems and training crews will become increasingly important for future EVA missions. These facilities provide controlled, readily accessible, visually representative locations where a variety of systems and operations can be tested before deployment at more remote locations (e.g., analog sites; discussed below) where modifications or repairs would be much more difficult, if not impossible.

Two examples of high-fidelity and long-duration facilities for testing EVA systems and training crews are the Integrated Human Exploration Mission Simulation Facility (INTEGRITY) and the EVA Remote Field Demonstration Test Site, also known as the “rock yard” (discussed in the Analog Sites section that follows), both located at JSC.

The INTEGRITY Project, and its facility (see Figure C.4-8), will perform testing of systems, vehicle architectures, and procedures associated with candidate human exploration missions that NASA may undertake in the future. In addition to EVA systems, INTEGRITY is intended to be a primary testing facility for habitability and human factors, life support and thermal systems, as well as crew health systems. Tests of automation and control systems, robotic systems, communication systems, in situ resource utilization systems, and advanced mission operations can also be accommodated. Integrated testing

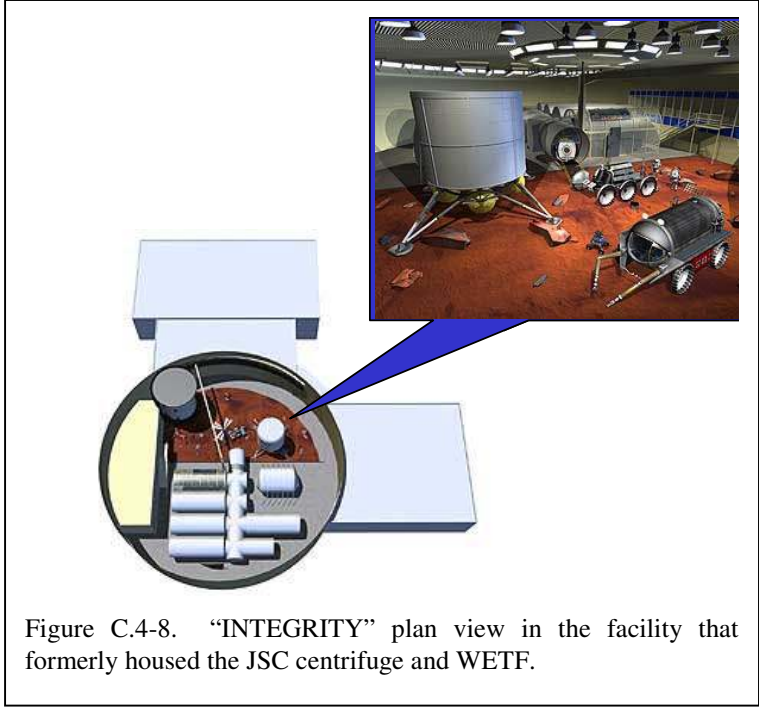

Figure C.4-8. “INTEGRITY” plan view in the facility that formerly housed the JSC centrifuge and WETF.

of some or all of these systems will provide additional insight into the viability of entire mission architectures well before these missions are approved and help reduce the risk associated with these mission concepts. INTEGRITY is in the advanced planning stages at this time.

Analog Sites. Analog sites have been, and continue to be, important for EVA system development, testing, and training. As discussed in the previous section, these sites can be grouped into two general categories: those specifically constructed to be representative of a particular site or feature on a planetary surface, and those that are naturally occurring on the Earth’s surface that were thought to have been created by the same or similar processes and thus should exhibit the same characteristics that would be found on another planet. Of those sites constructed during the Apollo era as facsimiles of the lunar surface, only those created by the USGS at Cinder Lake, Arizona, remain. This site has been pressed into service again for testing the next generation of lunar and Mars surface EVA suits. New sites, such as the JSC “rock yard,” are also being constructed to provide a variety of terrain features for testing and operations development purposes. Earth-based natural features that served as lunar analogs during the Apollo era are also being revisited, but new sites are also being added to represent features seen on Mars.



Figure C.4-9. Testing the deployment of a solar array at Cinder Lake, Arizona. (NASA photo)

Cinder Lake is located approximately 22 km (approximately 14 miles) northeast of Flagstaff, Arizona, within the ashfall from Sunset Crater’s last eruption. To construct this site, the builders used high-resolution images of the lunar surface to provide a representative size and spatial distribution of craters. Explosives

were then used to excavate craters of the appropriate diameter and depth. These explosives were also set off in a sequence that would create a similar pattern of overlapping debris among the craters, simulating the age distribution of that seen in the high-resolution images of the Moon. Contemporary testing of EVA suits and robotic equipment has taken advantage of this appropriately scaled terrain to test not only the mobility of these systems, but also for comparative tests of alternative equipment deployment procedures, as illustrated in Figure C.4-9.

The JSC EVA Remote Field Demonstration Test Site (aka the “rock yard”) is an approximately 30.5 m by 30.5 m (100 ft by 100 ft) outdoor facility used as an intermediate step in testing EVA hardware and operations—intermediate between bench or laboratory environment and relatively unstructured environment of analog sites. This facility (see Figure C.4-10) currently consists of a relatively smooth surface with rocks of various sizes and numerical densities embedded in the surface. This allows trafficability tests of EVA suits, robotic assistants, and other support



Figure C.4-10. A view of the JSC “rock yard” EVA system testing facility. (NASA photo)

equipment in a relatively controlled environment that is also close to support personnel and fabrication facilities, allowing relatively quick turnaround for repairs or modifications as tests are carried out. Plans call for this facility to be expanded to roughly four times its current area with larger features, such as relatively steep slopes, cliff faces, and provisions for drilling to shallow depths (see Figure C.4-11).

Naturally occurring analog planetary surface sites can be found in many places on Earth. In fact, many of the sites used for Apollo era training remain viable and are used for contemporary testing and

training. However, new sites are also being added to these sites to account for the additional terrain types found on Mars. Due to resource and logistical constraints, much of the testing of U.S. EVA systems has been performed in the desert southwest of the United States. This region is largely devoid of vegetation yet provides useful examples not only of craters, volcanics, and lava flows, but of fluvial and lacustrine formations as well. Examples of these sites and recent EVA testing are shown in the following figures.

Mission Support Facilities. During all EVA activities currently conducted from the ISS or from the Shuttle, ground personnel provide a dedicated support function. These personnel continue to provide all of the support functions described in Appendix B of this report, such as the CapCom and EVA console positions in the front room of Mission Control along with their associated back room positions, but are also expanding these functions. As described previously in the section on virtual reality training, an ISS EVA was recently conducted with the intravehicular support crewmember located on the

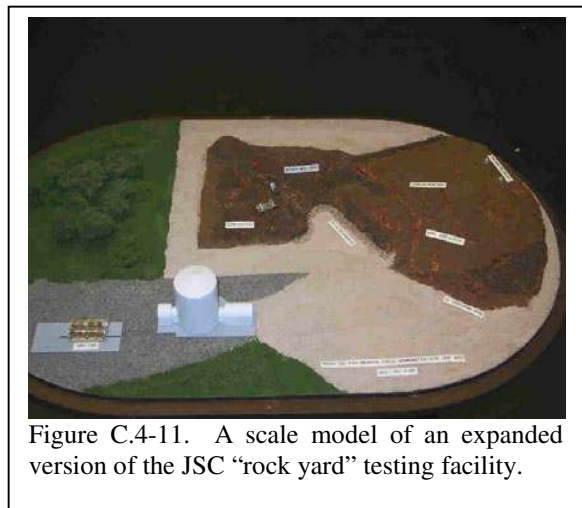

Figure C.4-11. A scale model of an expanded version of the JSC “rock yard” testing facility.

ground. This person is typically stationed on the vehicle from which the EVA is being conducted.

An advance in the technology used for these support functions has advanced with the rest of the mission control facility, of which they are a part. The latest Flight Control Room used for Shuttle missions is illustrated in Figure C.4-12. Communications advances as well as computer hardware and software advances have been



Figure C.4-12. The “white” Flight Control Room in the new Mission Control Center. (NASA photo)



Figure C.4-13. The Exploration Planning and Operations Center in the new Mission Control Center. (NASA photo)

incorporated into NASA’s Mission Control Center, allowing greater flexibility and expanded capability.

As with other systems described in this section, experimental facilities have also been developed for the mission support function. At JSC, a small facility named the Exploration Planning and Operations Center (see Figure C.4-13) was constructed to support various test activities and to experiment with new or different means of providing ground support functions. This facility has already been used to support field

tests not only in the desert southwest of the U.S., but also in the Canadian arctic at the Houghton Mars Project, and beneath the Gulf of Mexico, at National Oceanic and Atmospheric Administration’s Aquarius Undersea Research Center in Key West, Florida.

Another facility, the FutureFlight Central located at NASA’s Ames Research Center, is being used to investigate alternative means of Earth-based interaction with EVA crews (see Figure C.4-14). Originally developed to support research for the Federal Aviation Administration related to airport control tower operations, this facility has roughly a 270-degree field of view either computer-generated simulations or digital imagery from a remote location. This facility has also been used to support remote field activities, most notably simulated robotic and human EVA activities in the Canadian arctic at the Houghton Mars Project site.



Figure C.4-14. FutureFlight Central at the NASA Ames Research Center. (NASA photo)



Above left: Working on a lava flow near SP Mountain, Arizona. (NASA photo JSC2000-06280) Above right: On shore of dry lake near Baker, California (NASA photo)



Above left: Setting up geophones on a dry riverbed near Johnson City, Arizona. (NASA photo jsc2002e38774) Above right: A typical setup for field testing. (NASA photo jsc2002e38781)



A test subject in the Mark III experimental surface EVA suit at Meteor Crater, Arizona

Figure C.4-15. EVA field tests conducted over the past five years at various locations in the southwest United States.

APPENDIX D: LESSONS LEARNED FROM THE APOLLO LUNAR SURFACE EVAS

In 1993, the main purpose of a study conducted by Connors, Eppler, and Morrow (1994) was to identify those areas where the experiences of the Apollo lunar-surface astronauts led to basically similar conclusions and where planning lessons could be learned. Of the eleven surviving Apollo astronauts (at that time) who landed on the Moon, eight agreed to participate in this study. These participants were asked to comment on several different EVA hardware design and mission operations topics in the context of a future lunar mission that would be carried out with a crew of four and last for 45 days on the lunar surface. The results presented in the following paragraphs are derived from the responses of the eight astronauts interviewed as adapted from the study report. The referenced report contains additional background and explanatory material to support these conclusions.

Mission Approach. A major theme arising from discussions of mission approach was the need for a mission and design philosophy that emphasizes a *total system*—one that takes into account the integration of the person and the crew as a unit with the facilities and equipment. Respondents noted that both the mission itself and the EVA facilities and equipment should be designed to fit the tasks to be accomplished, and not the reverse. Design strategy should be marked by simplicity as well as reliability. The design should address only reasonably anticipated task requirements and should try to neither include capabilities that are not needed nor events that are unlikely to occur. In other words, design for the ordinary, not the extraordinary. A related response, voiced by several respondents, was that mission planning should not be based on a risk-free criterion. System design should, in general, address normal or expected events, with provision for emergency operations developed in parallel.

A second theme was the need for heightened autonomy and self-reliance on exploration missions. Primarily because of the length of future missions, the respondents saw a far more active role for the crewmembers in planning and executing their activities and in maintaining themselves and their equipment than has been required [on Apollo missions].

A third idea expressed by a number of respondents was that exploration missions need not be, and should not be, as tightly scheduled and controlled as were Apollo missions. For future, longer missions, astronauts need to accomplish overall mission goals, but they also need to operate at their own pace, to appreciate the experience they are having, and simply to relax and have fun.

Mission Structure. The respondents viewed the two-man EVA team [used for Apollo EVAs] as the desired basic unit of exploration. However, most felt that a one-person, limited EVA (brief duration; close to the habitat) would be acceptable and that flexibility would be needed in determining how particular EVAs should be constituted. For instance, some activities might call for a different mix of team members, whereas others might require three or even four crewmembers to be out on an EVA at the same time.

Regarding the amount of time spent per EVA, the consensus was that a 7- to 8-hour day was generally appropriate. Most respondents felt that, overall, an EVA every other day was quite doable and, if anything, represented too little EVA. However, a number made the point that

exactly when EVAs were run (e.g., one day on, one day off) should not be fixed in advance. They should be adjusted to take advantage of how the individuals are feeling, to address the tasks that need to be accomplished, and to keep the EVA activity fresh and interesting over the duration of the mission.

Suits. The importance of simplicity and reliability dominated responses of the subjects to suit features. For instance, respondents thought that being able to pull one's hands inside the suit to shake out the fingers or to reposition the microphone was an interesting idea but one that was not worth the complexity it would add. Respondents generally approved of changes that would reduce the required number of connections between the suit and the life-support system. Some also expressed concern that changes could increase the number of joints and bearings. These latter changes were perceived as introducing new potential points of failure. In this connection, several respondents specifically advised against introducing any more mobility into the suit than was required by the EVAs anticipated.

Regarding the requirements of habitat pressure, suit pressure, and pre-breathing, there was total agreement that the driving consideration should be adequate suit flexibility and mobility. The dominant belief was that suit flexibility demands that suit pressure be low, implying high O₂ concentration. Several respondents suggested that a high-O₂/low-total-pressure approach should be actively pursued. The argument was that the purpose of the lunar expedition is EVA; the purpose of EVA requires performing useful work; and a way to accomplish useful work is to be able to move about the surface and grasp objects easily. They felt that an O₂ suit environment approaching 100% would best accomplish this end.

The issue of the weight/bulk/mass/volume of EVA suits resulted in a complex of responses. To the specific issue of weight, some respondents did not see suit heaviness per se as a problem, with a couple suggesting that more weight might have been helpful during the Apollo EVAs. Other respondents (generally referring to post-Apollo suit-design concepts) felt that suit weight was indeed a problem and that limiting the weight of suits was an important consideration for future flights. Those who emphasized the need to limit suit weight also tended to emphasize the importance of reducing the volume required to transport and store the suits. Although distinctions were drawn regarding the particular question of weight, there were no differences in response to the broader question of bulk and mass. Everyone perceived bulk and mass to be an area where improvement is needed. Numerous references were made to the need to pull the suit closer to the body and to reduce the inertia involved in starting, stopping, and changing direction. It appears that from the standpoint of surface operations, the ideal lunar or planetary surface suit (and gloves) would hug the body as a second skin, fold into a small package, and weigh just enough to provide leverage and to keep the individual from lifting off the surface.

Concern was expressed that suits must last for 45 days and be maintainable with only routine care. Although there was agreement that a suit that is to be worn for 45 days must fit very well, there was only limited resistance to the idea of modularity in suits or even to shared suits. Gloves, however, were viewed as requiring customization [this is now state of the art and common practice with the introduction of the Shuttle EMU Phase VI gloves; see Appendix C Shuttle EMU Boots and Gloves]. Modularity, properly implemented, was seen by most as an aid to suit maintenance, as an effective way of assuring the availability of spares and backups, and as a reasonable means of controlling costs.

On the question of preparation time for EVAs, the bottom-line response was that what was acceptable was whatever it took. However, there was a clear desire to keep this time relatively brief and productive and to combine several activities, including pre-breathing, attending to physical needs, donning, suit checking, and mentally preparing for EVA.

Two related suit ideas, rear entry and external docking, drew mixed responses, as did the idea of a hard suit generally. Rear entry would have the astronaut enter and exit the suit through a door in the back of the upper torso of a hard suit [see the Orlan suit description in Appendix B.1 and C.1]. External docking would mesh this aperture area to a similar opening in the airlock, allowing the crewmember to exit the suit and enter the habitat while the suit remained outside [see the animation of this concept in Section 2.2 under the Lunar Surface Reference Mission, Figure 2.2-6]. Some viewed rear-entry as an aid to one-person donning and deployment of the suit and external docking as a significant advantage for dust control and general storage. Others felt that these design concepts, and especially external docking, introduced new concerns including sealing difficulties, change-out limitations, and problems with suit maintenance.

Reaction to the hard suit [concept] appeared to turn on how the respondent believed the various requirements for a 45-day mission could best be met. Clearly, all things being equal, everyone would prefer a soft, close-fitting, pliable suit. However, taking into account [the reference lunar]-type conditions, conclusions varied. Opinion was almost equally divided among those who opposed the concept of a hard suit, those who were open to the idea, and those who favored a soft suit but who believed that some aspects of a hard-suit design might improve performance.

Gloves. There was consensus that gloves/hand dexterity is among the most important EVA improvements needed. There was a restrained approval of the changes that have been made in the gloves since Apollo but the general feeling was that these improvements are not nearly enough. [Subsequent improvements, resulting in the Shuttle EMU Phase VI gloves, have addressed these concerns.]

Virtually all respondents reported that the gloves they had worn on Apollo imposed serious limitations on movements of the fingers, hands, and forearms. These limitations ranged from lack of adequate tactility and feedback, to reduced performance and muscle fatigue, to sores and bruises. Most found that muscle fatigue disappeared overnight and thought that it probably did not pose a cumulative threat. Several suggestions were offered including customization and careful fitting to anticipate pressurization changes and exercise and training to prepare the hands for a 45-day mission.

Acceptance or rejection of the concept of end effectors to extend hand capability seemed to depend on how intractable one thinks the glove problem is. Clearly, everyone would prefer a glove that stays in place, allows gripping without significantly extra effort, and provides an acceptable level of dexterity and feedback. This goal continues to be of highest priority. However, a few of the respondents felt that end effectors could be useful for some tasks and that the idea should be further examined.

Portable Life Support Systems. The PLSS used on the Apollo missions was given high marks for its functional capabilities in controlling atmosphere and temperature. Structurally, it did force one to assume a forward position, although most adapted readily to this shift. A few who were on earlier [Apollo] flights reported dehydration and difficulty with the placement of controls.

These problems were corrected on later flights; in any event, they were generally judged to be minor. Of more concern was the general mass of the system.

Most would prefer a system (i.e., the suit plus the PLSS) that has less mass and is easy to move around. A possible approach to reducing the mass of the pack that must be carried is to have astronauts change out consumables. Although most respondents did not express a strong objection to doing this, some thought it was not a good idea and all were concerned that such a change-out be accomplished safely and easily. (Safety and added complexity were the major stumbling blocks, but some also expressed concern about limiting how far one could wander and about having to break one's attention away from the primary work activity in order to deal with life-support issues.) In contrast to these interested-but-skeptical responses, the approach of using umbilicals while working near a rover was plainly rejected as both too dangerous, because of the possibility of tripping over cables, and too restrictive and cumbersome. Respondents generally favored integrating the PLSS with the suit as away of reducing failure points; of keeping donning and doffing times to a minimum; and of avoiding snagging on lines, cables, and projections.

Dust Control. Dust, a pervasive problem on the lunar surface, was viewed by the respondents primarily in terms of developing a strategy for management. Many thought the best means of control was to keep equipment that was exposed to dust separate from the living areas of the habitat. Airlocks or similar attached storage areas were seen as important in providing the space for maintenance of suits and other equipment. The role of tightly sealed connectors and covers to keep the dust out of the suit and the habitat was also stressed. This emphasis on isolating exposed materials, complemented by the elimination of dust through cleaning, vacuuming, mesh floors, etc. and strict enforcement of maintenance procedures was seen as the primary approach to dust management. A secondary line of defense emphasized avoiding disturbing the dust in the first place and preparing areas where high traffic is anticipated (e.g., around the habitat) so that a stable and non-deteriorating surface could be maintained. Some also suggested that materials might be selected with dust-avoidance or dust-control capabilities in mind, such as smooth surfaces and materials that are dust-repelling rather than dust-attracting.

Automation. There was broad and high-level support for integrating automation into the EVA system wherever appropriate. Automation was seen as especially useful when activities are repetitive or when extended setup times are required. Automation was deemed acceptable over a wide range of activities including setup, monitoring, and control. However, there was also concern that backups, manual overrides, and selectable levels of automation be available. There was some difference of opinion about whether the use of automation should extend to intricate activities such as landing on the lunar surface, but in general, automation was viewed as desirable, provided it did not contribute substantially to mission complexity and that it remain under the control of the crewmember. Several respondents also mentioned the extended role they saw for robotics working in conjunction with crewmembers.

Automated suit checkout generally was viewed positively, provided that proper safety controls and backups were in place. Opinion on the desirability of automated control of suit atmosphere and temperature differed, with some thinking it would be workable and others believing it to be either too complex or having too great a lag time.

Information, Displays, and Controls. The respondents wanted the information presented to be simple and limited to only what was needed. Primarily, they wanted information relevant to the

current operational task. Secondly, they were interested in having safety-related status information. Most felt this status information should be available on a call-up basis. Alarms were favored for very significant events, but the preference for normal operations was to have the ground or the habitat in an active monitoring role, calling issues to the attention of the crew only if necessary. In this way, the respondents felt the EVA crew could concentrate on the task they were performing.

Visual displays were envisioned as supporting operational tasks, with aural displays used for alarms. A number of respondents expressed interest in examining how head-up displays might be incorporated into EVAs, although reservations were also expressed that they might not work well in EVA situations. Similarly, although there was a general interest in the possibility of voice-activated displays, there were also reservations about their reliability and a concern that their use could be at cross-purposes with other voice communications. A number of respondents also mentioned the importance of having good visual and aural communication links with both the ground and the habitat. The habitat was frequently mentioned as a key communication node in the EVA communication network, replacing the monitoring function that ground control had played in the Apollo missions; it was also seen as having information requirements of its own associated with laboratory activities such as information processing and data reduction.

Checklists are a common form of activity management. Electronic checklists are now being introduced in a number of areas. These systems have the advantage of being able to capture and organize information as well as display it in new ways that aid the user. The respondents in this study appreciated the need for rapid information updating and display in support of lunar and planetary operations. They also accepted, in concept, the use of electronic displays and checklists to present this information to the EVA crew.

Rovers. The use of the rover to provide auxiliary and/or supplementary life support was generally considered desirable, provided the disconnections/connections could be accomplished routinely and safely and that the activity did not add substantially to the complexity of the mission. The added distances that could be traversed were mentioned by several respondents as a significant advantage of rover-supplied consumables. Potential use of a rover as a safe haven in a radiation event drew mixed responses. Those who did not support this concept felt that it introduced too much complexity at an early stage of exploration. Respondents agreed that a second rover was desirable at some early point in follow-on missions in order to extend surface operations and also as a backup to the primary vehicle.

The respondents thought that loading, storage, and access to equipment, tools, and supplies need to be improved, possibly by the use of a snap-on pallet or some other device. While there were other specific suggestions about what might be provided on the next generation of rovers, several emphasized keeping the rover simple, thereby allowing repairs (to the rover itself, as well as to facilities and equipment) to be accomplished on site by the surface crew.

Tools. There was general agreement that it is difficult to keep equipment in place on the lunar surface, primarily because of its low weight under lunar gravity. There is also the problem of surface cables not lying flat. However, most respondents thought the difficulty of managing and using tools to be a more important concern. The light weight of the tools was mentioned as a factor but the main problem reported was in gripping—and particularly in maintaining a

grip—on hand tools. The necessity of continuously exerting pressure just to hold on to a tool caused considerable difficulty, particularly when using the hammer. Some respondents related these problems primarily to limitations of the suit and glove and did not consider them tool issues per se.

Regarding what might be done to reduce the muscle fatigue associated with manipulating hand tools, a promising suggestion was to provide an attachment such as a wrist loop or other means of securing the tool. With this, the user could relax his grip without losing the tool. Some saw value in trying to achieve a better fit between glove and tool handle. However, most thought that having to snap tools onto a customized handle was more trouble than it was worth. There was also little enthusiasm for walking, sitting, or other aids, with several commenting that they had rested adequately simply by leaning on the suit. (This raises the question of how much more tiring it might be to operate in a suit that does not support itself.)

Regarding access to tools and storage of samples, several suggestions were offered. Most found the buddy system of tool access to be acceptable under most anticipated conditions. However, other arrangements would have to be made if one were operating alone. For collecting and carrying samples, something with a wide mouth, like a shopping bag, was the respondents' container of choice.

Operations. There was significant agreement among respondents about how planning and implementing for [a lunar]-type mission should proceed. A general movement toward increasingly greater crew autonomy in day-to-day planning and activity would be combined with strong ground involvement in overall planning of mission objectives and operations. In general, mission operations would be planned to a high degree in advance of the mission by all involved groups in order to meet operational and scientific objectives. This planning would serve as the basis for further planning of near-term activity, which would be developed jointly by the crew and the ground during daily discussions. However, the crew would have a high degree of flexibility in implementing the daily plan and could adapt schedules to fit events as they evolved. Several of the respondents expressed the desire to be able to spend as much time as necessary in documenting scientific findings, particularly in the event of a serendipitous discovery. It was assumed that the ground would retain a significant role in planning and monitoring during EVA. One reason given was to free the crew for scientific work by relieving them of detailed planning and monitoring tasks. With later missions, the habitat crew was seen as taking on an increasing role in planning, and especially in monitoring EVA operations.

A related issue was the reliability of equipment in general, and of experiments in particular. The respondents felt that experiments should be designed with a view toward making them less sensitive to the elements while also allowing for easy repair, if that should become necessary.

Given adequate consumables, the limiting EVA factor during nominal operations was generally assumed to be fatigue, both mental and physical. For off-nominal events, such as a suit or glove puncture, loss of PLSS, or habitat failure, respondents viewed the preferred solutions from two perspectives. First, for each projected failure, it must be determined in advance when one could and should attempt to fix the problem in situ. Second, mission rules reflecting those decisions must be put in place and strictly enforced. For instance, walking 20 km (12 miles) or so back to the habitat following a failure of the rover, although a stretch, was considered quite doable under favorable conditions and if required. This distance, modified by time constraints, consumables

remaining, and surface conditions, could then form the basis of a mission rule involving rover failure.

During EVAs, astronauts' vision can be impaired by several factors. During Apollo, the peripheral vision of astronauts was limited by the physical structure of the helmet and movement within the suit. Other visual problems such as high contrast, shadows, and washout relate to the characteristics of the lunar surface environment itself. The general belief was that, to some degree, one could adapt to these differences over time. The visual area that caused the most significant surface problems involves the judgment of distance. Problems in judging distances, combined with the more general condition of not knowing where one is, indicates that range-finding, navigational, and related equipment must be available, either as part of a rover vehicle or in some other way.

Regarding operating during high noon and during lunar night, the respondents felt that neither condition should necessarily preclude EVAs, provided acceptable thermal conditions could be maintained. For the high-noon condition, most felt that taking three to five days out of the mission was an unnecessary precaution. However they also felt that because visual conditions would be difficult, it would be advisable to plan activities closer to the habitat. For lunar night, respondents believed that operations could proceed fairly routinely with supplementary lighting as needed. Some respondents also stressed the value of using teleoperations where EVA was not practical and also as a supplement to routine activities.

Training. The astronauts' suggestions for training differed from other discussion topics in that there was wider diversity in emphasis. This diversity related both to different experiences associated with different missions and to the interests of particular individuals. The following represents a subset of suggestions where there was cross-respondent agreement.

Respondents mentioned the need to train under realistic conditions. Specific areas included training with tools of the same weight and stiffness as one would obtain on the lunar or planetary surface, maintaining one's own equipment during the training process, operating in the pressurized suit and for the extended number of hours one would have to wear it on a 45-day mission, and training for the mission as an integrated whole and not just as segmented parts.

Conclusions. The results of this study revealed a level of agreement among the Apollo lunar surface astronauts that can be summarized as follows:

- 1) Emphasis should be given to the integration of crew, equipment, and facilities as a total system.
- 2) All subsystem designs should be based on fundamental principles of simplicity and reliability. Given a trade-off, simplicity and reliability are to be preferred over added functionality.
- 3) The EVA hardware-related items most in need of improvement are the bulkiness/inflexibility of suits and the (inadequate) manipulability/dexterity of the gloves.
- 4) Equipment should be designed to fit EVA task requirements and the training of crews should be on actual tasks, equipment, etc.

- 5) Future missions will require increased crew autonomy. Crews will need greater flexibility in operations, particularly in daily scheduling.
- 6) The habitat crew will play an increasingly important role in supporting EVA crew operations, replacing some of the activities previously performed by ground control.
- 7) High levels of maintainability and reparability must be designed into experiments as well as into equipment and facilities generally.
- 8) Extended missions will require ways to achieve and sustain high-level mental performance.

APPENDIX E: ADVANCED/REVOLUTIONARY CONCEPTS

This Appendix provides a selected sample of EVA systems or technologies that could be described as advanced or revolutionary, based in part on information submitted in a response to an email request for such material as part of this study and in part from researching the literature. It is not the intent of this Appendix to provide an exhaustive compilation of advanced or revolutionary systems, but rather to expand upon the systems and concepts identified in Section 4. It should also be noted that several systems identified as “advanced” were described previously in Appendix C, although these should have been noted if reference was made to them.

The remainder of this Appendix is not divided into sections but the organization does follow the functional breakdown described in Section 2 and Appendix A. EVA suit systems and technologies are discussed first. This is followed by a discussion of transportation systems. Several airlock concepts conclude the system descriptions in this Appendix.

Mechanical Counter Pressure Suit. From a physiological perspective, there are two essential factors needed by the human body to function in a vacuum or near vacuum: oxygen and some external pressure. Oxygen is needed by both the lungs and skin for respiration. The vascular system would also expand due to a lack of an external pressure balancing normal internal blood pressure, causing blood to pool and reducing the cardiovascular system’s ability to deliver oxygen throughout the body. All spacesuits used to date have provided these two factors by means of a pressurized, airtight garment. An alternative is the use of a garment that provides external pressure mechanically in combination with a pressurized breathing apparatus. This alternative approach is generically referred to as a mechanical counter pressure suit.



Figure E-2. A mechanical counter pressure concept put forward by Honevwell.

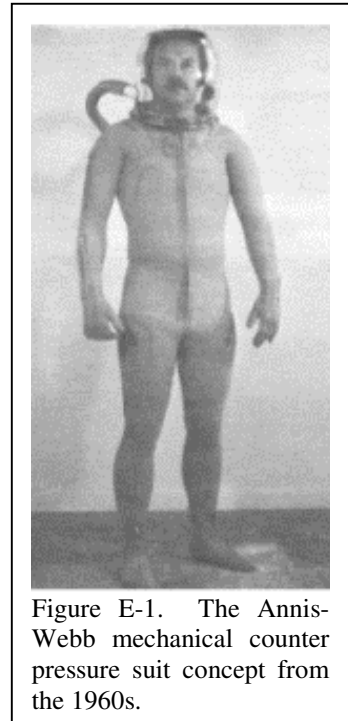

Figure E-1. The Annis-Webb mechanical counter pressure suit concept from the 1960s.

In the early 1940’s J. P. Henry, who introduced the partial-pressure suit, thought of the elastic suit concept but did not test it. Some time

later, W. E. Hull, at the Aeromedical Laboratories at Wright-Patterson Air Force Base, actually had such a suit constructed, but he didn’t pursue the idea further because breathing was uncomfortable and the heavy elastic material then available was stiff and hard to bend. In 1967 Webb Associates gained support for limited testing of the elastic suit concept in a feasibility study contracted by NASA (Webb and Annis, 1971). Two NASA reports and several journal articles were published between 1967 and 1971 by Webb and Annis describing these studies of a Space Activity Suit (SAS). This line of study was

cancelled with the demise of the Apollo Program. These studies demonstrated dramatic

improvements in reach, dexterity and tactility compared with full-pressure suits due to the replacement of stiff joints and bearings with light, flexible elastic fabrics. However, improvements were needed in methods for donning and closing the garments.

Subsequent research has continued at various locations. MIT conducted flexibility tests with basic mechanical counter pressure elastics during the mid 1980's and staff are currently investigating a "skinsuit" based on the same principle. Honeywell, University of California, San Diego, and Clemson University have also conducted physiological and design testing on gloves and arms.

The “**Chameleon Suit**” is a revolutionary concept for EVA garments and portable life support systems in which thermal management of the crewmember and other EVA equipment is accomplished without the use of consumables. This is accomplished by rejecting metabolic and equipment waste heat through the outer surface of the space suit. Thermal control is provided by varying both conductive/convective and radiative heat transfer characteristics of the garment. Conduction and convection are controlled by varying the physical thickness or loft of the insulating garment, while radiant heat transfer is varied by controlling the infrared emissivity of the layers of material which comprise it (see Figure E-3).

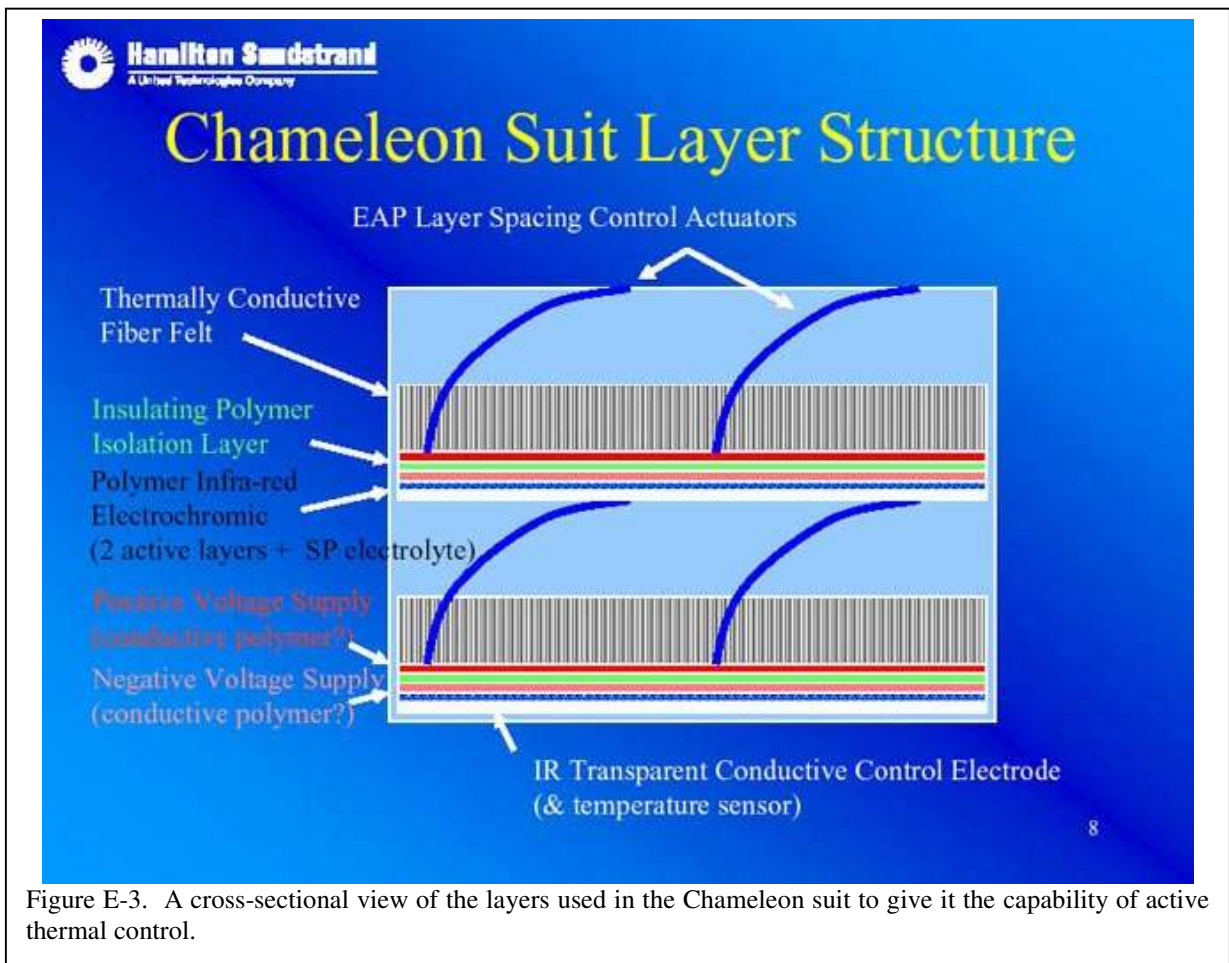

Figure E-3. A cross-sectional view of the layers used in the Chameleon suit to give it the capability of active thermal control.

Operationally, the Chameleon Suit eliminates reliance on one of the major consumable resources that currently limit the duration of EVA missions: the water presently used for heat rejection in a

sublimator and of the equipment required for its storage, management and use. These gains are partially offset by added weight in the pressure suit for the new functional elements required to implement the Chameleon Suit concept. However, because the water is physically lost through the sublimation process, a replacement supply must be available. For the longer duration missions envisioned for the future of EVA, the number and duration of EVA sorties could translate into a significant mass and volume of water that must be accounted for in overall mission planning.

By eliminating water as a consumable heat sink one barrier to extending EVA beyond the nominal endurance limits in the event of emergencies is also eliminated. With the Chameleon Suit, extended thermal control endurance can be provided with only a battery replacement (or recharge) or supplementary power connection. There is no need for water recharge provisions or supplementary cooling loop support on an EVA support rover to meet this need (see the discussion of unpressurized rovers elsewhere in this Appendix). This represents a potentially significant simplification and overall mission cost savings as well as an opportunity to increase science support capability on the rover.

Operational benefits are also evident in comparison to earlier concepts for no-expendables thermal control. Because it provides increased heat rejection capability, the Chameleon Suit eliminates most metabolic profile restrictions implicit in those concepts. Because it provides actively controlled heat transfer from all surfaces of the spacesuit system, it avoids restrictions on work site and orientation based on maintaining favorable radiator orientation.

The Chameleon Suit also provides increased crew protection against two of the hazards of working and exploring in space. By distributing mass for heat transfer (and possibly other life

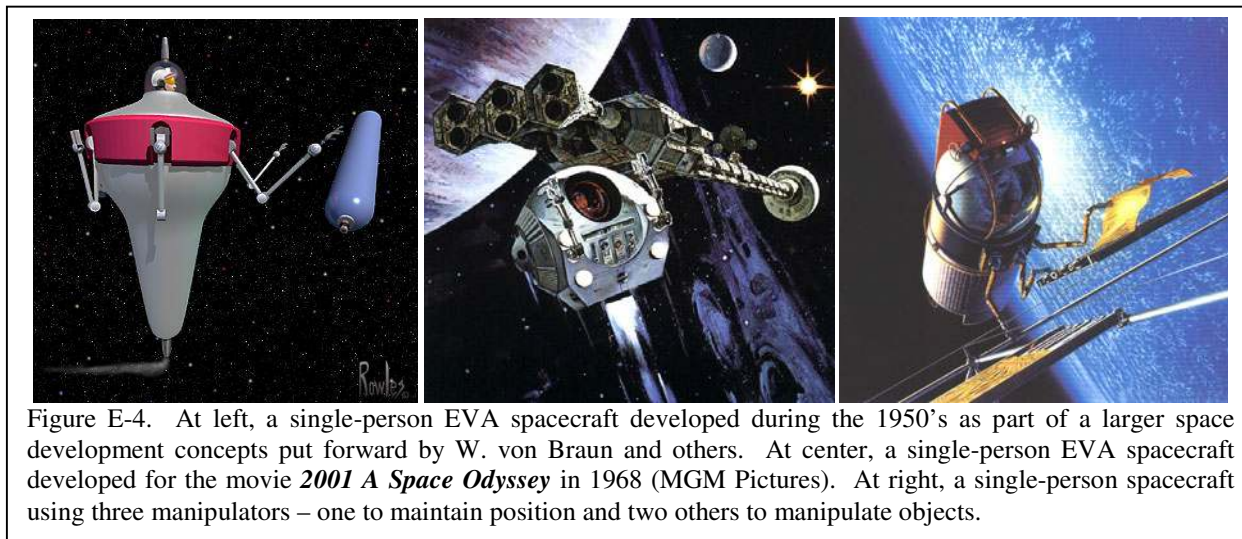

support processes) over the surface of the suit, it increases the level of shielding between the crew person and incident micrometeoroids and orbital debris (MMOD) and radiation (identified earlier in this report as areas of increased performance need for EVA systems used in these advanced mission concepts). Both have been a matter of concern from the outset of the space program, and are cumulative hazards such that the risks increase as more EVA is performed to accomplish challenging future missions.

(Adapted from Hodgson, Edward W., “A Chameleon Suit to Liberate Human Exploration of Space Environments,” NIAC Contract #07600-067, December 2001.)

Single-Person Spacecraft. A single-person spacecraft occupies a niche between large, multifunction human spacecraft and EVA suits. This vehicle concept is built around a rigid pressure vessel large enough for a single person. The rigid pressure vessel allows for internal atmospheric pressures much higher than is typical for EVA suits (up to ambient pressures of larger spacecraft. This eliminates the need for a pure oxygen atmosphere, the associated time for prebreathing, and the added precautions that go with working at this pressure and in this atmosphere. However this also means that the gloved hand must be replaced with a manipulator and end effector. These vehicles have also been large enough to require most of the subsystems typical of larger human-rated spacecraft, such as propulsion, navigation, thermal control, communication, and power. Conceptual designs for this vehicle have evolved over time (see Figures E-4), but typically retain the basic features of a rigid pressure vessel and several small remote manipulators.

Unpressurized Rovers. Unpressurized rovers have been recognized as a means of expanding the area that can be explored by humans while on an EVA traverse. The Apollo Lunar Rover Vehicle (see Appendix B) greatly expanded the range of the Apollo surface traverses despite the fact that the A7L EVA suits had not been significantly modified. This functional capability will remain a necessity for future planetary surface traverses although their total compliment of functions will expand.

The useful range of unpressurized rovers will continue to be defined by the walking range of astronauts in EVA suits due to the continuing need for the crew to be able to return to a safe location in case the rover breaks down or is immobilized. A “safe location” is not necessarily constrained to be the landing site or a central habitat as was the case in Apollo if here are other locations to which the astronaut crew can safely retreat, locations such as a pressurized rover, a mobile base camp, or a cache of emergency supplies. The addition of a second rover that is capable of carrying all EVA crewmembers would also relax this “walk back” constraint.

One of the proposed additional capabilities for unpressurized rover is an augmented supply of PLSS consumables and functions – power, breathing gases, and thermal control. An EVA crew could tap in to this additional resource while riding on the rover to conserve the limited supply in a backpack unit. In so doing, it is conceivable that the PLSS backpack could be reduced in size and mass. However, reducing the size, mass, and, by inference, the duration of the PLSS backpack must be traded against the maximum distance away from a safe location to which the crew must still be able to walk back to in case of a rover breakdown.



Figure E-5. One example of an unpressurized rover capable of carrying two crew and additional equipment. (NASA image)



Figure E-6. An unpressurized rover equipped with a small drill powered by the rover's power plant and energy supply. (NASA image)

Range will not be the sole determining factor for the size of the power plant or the supply of stored energy on board the unpressurized rover. These rovers are likely to be called upon to tow trailers carrying additional supplies and equipment or to power other scientific equipment. An example is a subsurface drill and analytical equipment used to characterize the material brought up to the surface.

Concepts for this class of rover have been proposed with four or six wheels or with tracks. The power source also varies, with concepts proposed using batteries, fuels

cells, and small radioisotope devices. Each option has advantages and disadvantages, none of which have thus far been shown to be uniquely better than all of the other concepts.

Dustlock. Another lesson learned from Apollo was the highly intrusive and abrasive nature of the dust. This same material could pose a long-term breathing hazard for the crew. Mars is also known to have very fine dust, although its abrasiveness and breathing hazard characteristics are yet to be determined. In both these locales dust will inevitably coat EAV equipment surfaces and will be brought into the habitable spaces unless controlled. Garment materials and airlock architecture can be used to aid in controlling this material.

One concept put forward to help manage the amount of dust that enters the EVA suit and the habitable volume occupied by the crew is a combination of suit "coveralls" and a segmented airlock, sometimes referred to as a "dustlock."

The first element in a multilayered strategy for dust management is to cover those portions of the EVA suit most likely to be covered with dust in another removable layer of material. This layer would remain outside of the habitat at all times. This relatively simple technique should keep the majority of the surface dust outside. However, a number of attributes of this cover layer still remain to be investigated: (1) the material; (2) the ease of donning and doffing a removable cover layer while in a pressurized suit; (3) whether it should be a full "jump suit" style or "hip waders" and pull-on sleeve protectors; and (4) whether to have them disposable or reusable.

The next layer in this representative dust management approach is a segmented airlock, an example of which is depicted in Figure E.7. In this implementation, the first step in reentering the habitat is to enter an outer room (that remains unpressurized) where all loose dust and other material is brushed off. This room would also have an open grate floor so that any of this loose dust or other material would fall through the floor to the exterior environment. After brushing off loose material, the outer "coverall" could be removed. The returning crewmember would then move into the first airlock chamber (the middle chamber as depicted in Figure E-7, also referred to as the Crew Lock) and take a dust removing "air shower." The "air-shower" uses the repressurization air to blow-off the dust and collects it in filters in the floor. At this point the crewmember can connect the habitat life support system to their PLSS using an umbilical. The crewmember would remain in this part of the airlock and use a vacuum to remove as much of the

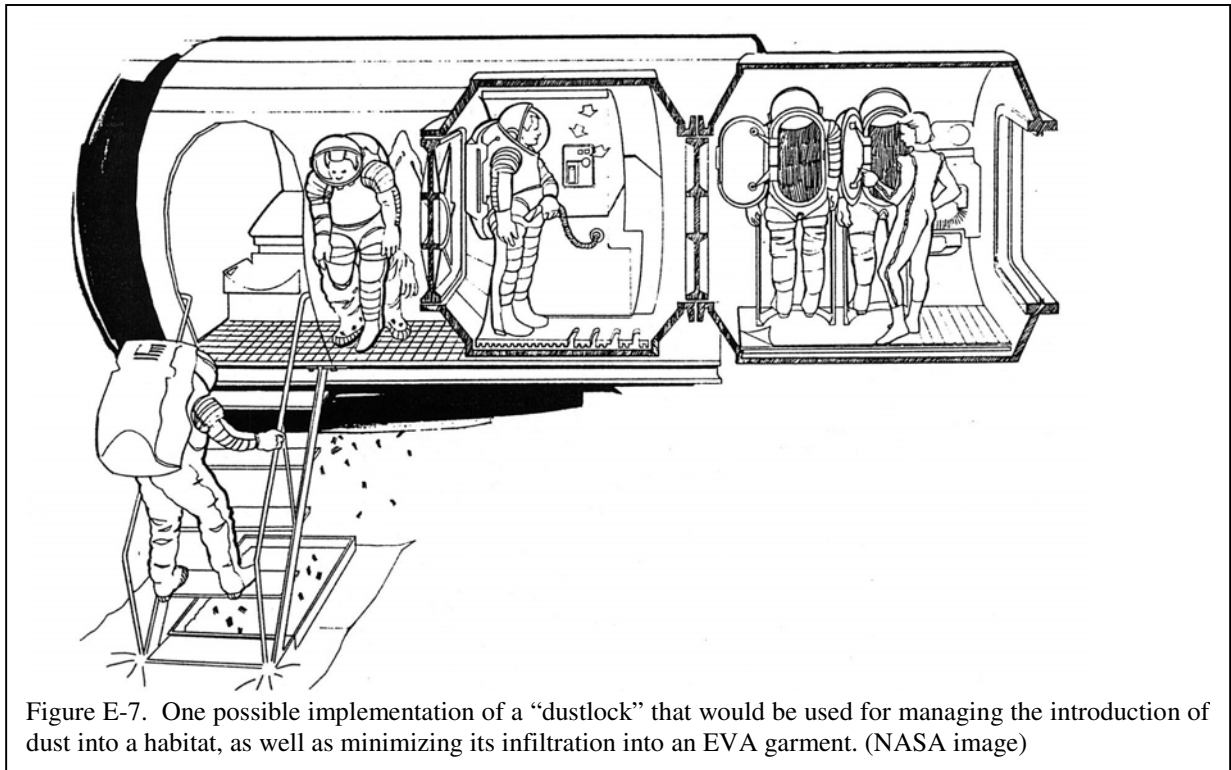

remaining dust as possible. The crewmember then connects the suit to a support stand so that they can exit the suit. Protective booties and gloves are put on and the crewmember exits the Crew Lock for the Equipment Lock (the third, or right-most, chamber in Figure E.7). At this point a crewmember (that may or may not be the same person that just completed the EVA) wearing protective clothing, booties and, if necessary, a facial mask, goes into the Crew Lock and washes or wipes off any remaining dust residue (assuming a smooth textured surface). After this the EVA suit is moved into the Equipment Lock and connect it to the Servicing and Maintenance Rack for other routine post-EVA servicing. The crewmember removes their dust gloves and booties and enters the habitat dust-free.

Although this is not necessarily the only solution to the dust management problem, comparable activities to those described will be necessary to maintain an appropriate level of separation between the outside environment and the habitat interior.

(Adapted from Kennedy, K. and Harris, J. “Dust Control Research for SEI,” in Proceedings of the Third International Conference on Engineering, Construction, and Operations in Space, Volume I, pp. 398 – 407, 31 May- 4 June, 1992.)

Suitport. For the mission durations and number of EVA sorties identified in the future vision of EVA, consumables or expendables can become a significant contribution to overall mass. The current STS Orbiter airlock is not pumped down for EVA. The atmosphere is bled off to vacuum and sacrificed. This procedure is satisfactory for the Shuttle with a maximum of three EVAs per 10 day flight. The Crew Lock portion of the ISS Joint Airlock is partially pumped down but the remaining air (about 345 mbar or 5 psi) is vented overboard through a valve on the outer hatch (see Appendix C). The Crew Lock was built as small as possible to minimize the amount of air

lost from the ISS to space during this venting process; the Crew Lock actually loses less air to space than the Shuttle airlock.

Even though airlocks can be pumped down to a small fraction of their original atmosphere, losses still occur and make-up gases become an item that must be tracked as an expendable item. This is also an issue for pressurized rovers. Concepts have been proposed that can significantly reduce the lost breathing gas that occurs for each airlock cycle. One concept, known as a “suitport,” actually connects the EVA suit to an outer wall (see Figure E-8). The crewmember enters the suit through an airtight hatch in the back of the suit. This is actually a double hatch – one part seals the EVA suit for detached operation while the other part seal the habitat volume from the outside environment.

The nature of the suitport system permits the virtual elimination of pumpdown in routine usage of the system. Only an interstitial volume between the portable life support system and the hatch need be pumped down. This represents a volume reduction from about 25.5 m³ (900 ft³) for a conventional airlock design to about 0.03 m³ (1 ft³) or less for the

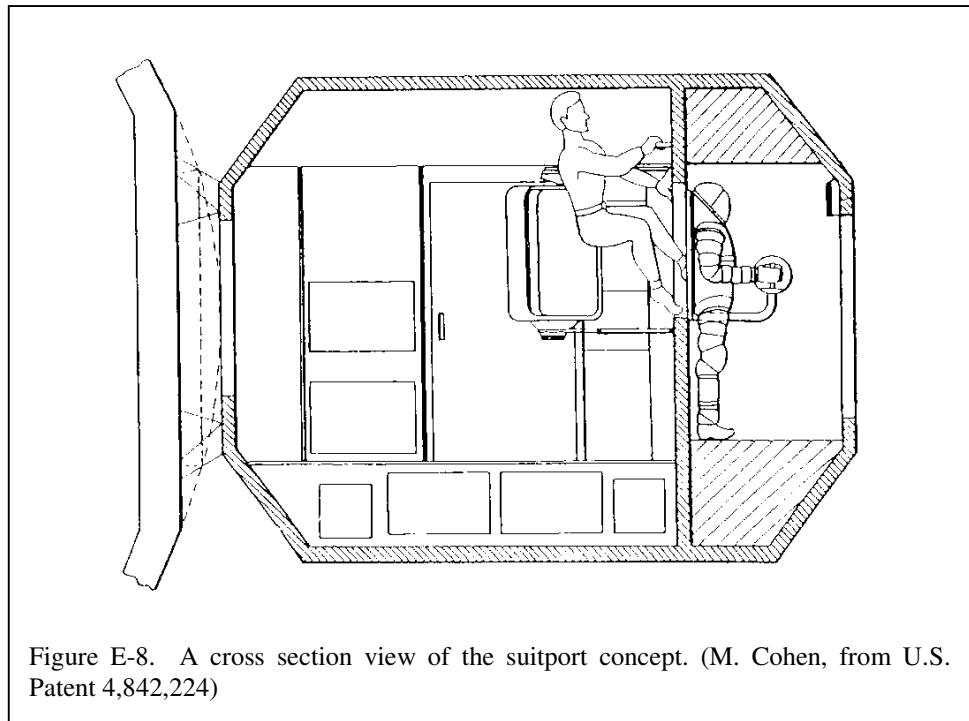

suitport. This remaining interstitial volume is so small that it could even be sacrificed rather than pumped down. Pump down time, power and pump cooling are therefore eliminated in this mode of operation.

The suitport offers the additional benefit of dust control. By sealing the suit to the outside of the shirtsleeve environment, it is possible to isolate the dust (or other contaminants) from the crew. The crewmember can don and doff the suit through the suitport without needing to decontaminate after each EVA sortie.

APPENDIX F: BIBLIOGRAPHY

The following is a representative list of reports and technical papers that discuss topics covered in this report in more detail. This list is not intended to be comprehensive, but rather is provided to the reader as a source for accessing additional information on these topics.

Advanced EVA Website <http://www.jsc.nasa.gov/xa/advanced.html>

Annis, Webb, Space Activity Suit, NASA CR-1892, NASA, Washington, D.C., November 1971.

Bioastronautics Critical Path Roadmap <http://criticalpath.jsc.nasa.gov>

Boucher, Hodgson and Murray (Hamilton Sundstrand and Ames Research Center),
“Investigation of EVA Information Interface Technology in a Mars Analog Arctic Field
Science Setting,” 2002-01-2312, ICES.

Budden, N., Mars Field Geology, Biology and Paleontology Workshop: Summary and
Conclusions, LPI Contribution Number 968, Lunar and Planetary Institute, Houston,
Texas, 1999.

Cohen, M. (Ames Research Center), “Pressurized Rover Airlocks,” 2000-01-2389, ICES.

Cuccinotta, Baddhwar, Saganti, Schimmerling, Wilson, Peterson, Dicello, Space Radiation
Cancer Risk Projections for Exploration Missions, NASA/TP-2002-210777, August
2002.

Drake, B., Reference Mission Version 3.0; Addendum to the Human Exploration of Mars: The
Reference Mission of the NASA Mars Exploration Study Team, Report No. EX13-98-
036, NASA Johnson Space Center, Houston, Texas, June 1998.

Duke, M., Mars Surface Mission Workshop, LPI Contribution Number 934, Lunar and Planetary
Institute, Houston, Texas, 1997.

Fullerton, R. and Trevino, R., “Review of Components for Large Spacecraft,” IEEE, Feb 2002.

Goldfarb, Hodgson (Hamilton Sundstrand), “Advanced, Lightweight, Space Suit Primary Life
Support System for Mars Exploration,” 2001-01-2167, ICES.

Graziosi, Stein (ILC Dover), Ross, Kosmo (NASA JSC), “Phase VI Advanced EVA Glove
Development and Certification for the International Space Station,” 2001-01-2163, ICES.

Griffith, A., Operations Concept Definition for the Human Exploration of Mars, NASA JSC,
DV-00-0014, May 2000.

Harris, G., Origins and Technology of the Advanced Extravehicular Space Suit, American
Astronautical Society, 2001.

- Hodgson, A Chameleon Suit to Liberate Human Exploration of Space Environments, NASA Institute for Advanced Concepts, <http://www.niac.usra.edu/>, December 2002.
- Hoffman, S. and Kaplan, D., Human Exploration of Mars: The Reference Mission of the NASA Mars Exploration Study Team, NASA Special Publication 6107, NASA Lyndon B. Johnson Space Center, Houston TX, July, 1997.
- Hoffman, S., The Mars Surface Reference Mission: A Description of Human and Robotic Surface Activities, NASA Technical Publication 2001-209371, NASA Lyndon B. Johnson Space Center, Houston TX, August, 2001.
- Honeywell, FTL Happold, Clemson University, “Inflatable Airlock System,” 2002-01-2314, ICES.
- Jalali (Lockheed Martin), “Water Membrane Evaporative Cooler Testing and Analysis for Advanced Spacesuit Portable Life Support System,” 2000-01-2390, ICES.
- Knudsen, Tourbier (Honeywell International), Jarvis (Clemson University), Tanaka, Limberg, Hargens (University of California San Diego), P. Webb, “Physiological Effects of Underpressure and Overpressure in a Study of Mechanical Counter Pressure Suits,” 2002-01-2317, ICES.
- Korona and Akin (University of Maryland), “Hybrid Elastic EVA Glove,” 2002-01-2311, ICES.
- Koscheyev, Leon (University of Minnesota), “An Advanced Physiological Based Shortened Liquid Cooling/Warming Garment for Comfort Management in EVA,” 2002-01-2413, ICES.
- Kosmo, J., “Remote Field Site Space Suit Mobility Study Test Report; Flagstaff, AZ, May 2-17, 1998,” JSC 39096, NASA Johnson Space Center, Houston, TX, June 3, 1998.
- Kosmo, J. and et al., “Results and Findings of the Astronaut-Rover (ASRO); Remote Field Site Test Silver Lake, CA (Mojave Desert), Feb. 22-25, 1999,” JSC 39261, NASA Johnson Space Center, Houston, TX, March 3, 1999.
- Kosmo, J., and Ross, A., “Results and Findings of the Representative Planetary Surface EVA Deployment Task Activities; Remote Field Site Test Location Flagstaff, AZ (Sept. 2-15, 2000),” JSC 40106, NASA Johnson Space Center, Houston, TX, October 25, 2000.
- Kozloski, L., U.S. Space Gear, Smithsonian Institution Press, 1994.
- Large Structures Workshop (May 2002) and Human/Robotic Workshop (November 2001), <http://ww.icas.edu/workshops/hress01.html>
- Mars Exploration Workshop, Feb 2001, <http://www.lpi.usra.edu/publications/reports/CB-1089/>

Moon Beyond 2002 Conference, <http://www.lpi.usra.edu/meetings/moon2002>, Sept 2002.

Murdoch, Thibaud-Erkey (Hamilton Sundstrand), Sirkar, Obuskovic, Chen (New Jersey Institute of Technology), “Membrane Based CO₂ Removal from Breathing Atmospheres,” 2000-01-2392, ICES.

NASA Exploration Team (NEXT) Guidelines and Capabilities for Designing Human Missions, http://research.hq.nasa.gov/code_u/nra/current/NRA-02-OBPR-01/index.html, <http://advtech.jsc.nasa.gov/reference Rack.shtm>, March 2002.

NASA Exploration Team (NEXT), Space Robotics Technology Assessment Report, L. Pedersen, D. Kortenkamp, D. Wettergreen, and I. Nourbakhsh, editors, December 2002. NEXT Websites <http://hedsadvprograms.nasa.gov> and <http://THREADS.nasa.gov>

NASA Advisory Council, ReMAP, <http://www.nasa.gov/newsinfo/remap.html>, August 2002.

NASA Vision and Mission Statements, <http://www.hq.nasa.gov/office/codez/new/plmission.html>, http://www.nasa.gov/newsinfo/pioneering_the_future.html

National Research Council, Decadal Solar System Survey, <http://www.nationalacademies.org/ssb/ssefrontpage.html>, 2002.

National Research Council, Precursor Measurements for Human Operations on Mars Surface, <http://www.nap.edu/books/0309084261/html/>, May 2002.

Pitts, Brensinger, Saleh, Carr, Schmidt, Newman, Astronaut Biosuit for Exploration Class Missions, NASA Institute for Advanced Concepts, <http://www.niac.usra.edu/>, 2001.

Portree, David S.F., and Trevino, Robert C., Walking to Olympus: An EVA Chronology, Monographs in Aerospace History Series #7, NASA History Office, Washington, DC, October, 1997.

Radiation Shielding Conference, <http://sirest.larc.nasa.gov/workshop02/>, LaRC, April 2002

Ross, Kosmo (NASA JSC), Moiseyev, Stoklitsky (RD&PE Zvezda), Barry (David Clark), Hodgson (Hamilton Sundstrand), “Comparative Space Suit Boot Test,” 2002-01-2315, ICES.

Stuster, J., Bold Endeavors: Lessons from Polar and Space Exploration. Annapolis, MA: Naval Institute Press, 1996.

Thornton, Xu, Nair (University of Missouri – Columbia), “Thermal Comfort Control of an Advanced Space Suit,” 2001-01-2268, ICES.

Trachtenberg, Ge, Cowan and Qin (Sapient's Institute), "CO₂ Capture by Enzyme-Based Facilitated Transport," 2002-01-2267, ICES.

Trevino, Orndoff, Tang (NASA JSC), Gould, Trifu (Aspen Systems), "Aerogel-Based Insulation for Advanced Space Suit," 2002-01-2316, ICES.

Von Braun, W., The Mars Project, University of Illinois Press, Urbana, IL, 1953.

Webb, P., Annis, J., The Principle of the Space Activity Suit, NASA CR-973, Dec 1967.

Webb, P., Annis, J., Development of a Space Activity Suit, NASA CR-1892, Dec 1971.

Zubrin, R., "Mars Direct: A Simple, Robust, and Cost Effective Architecture for the Space Exploration Initiative," AIAA 91-0326, 29th Aerospace Sciences Meeting, held in Reno, NV, 7-10 January 1991.

| REPORT DOCUMENTATION PAGE | | | Form Approved OMB No. 0704-0188 | |
|--|---|--|---|----------------|
| Public reporting burden for this collection of information is estimated to average 1 hour per response, including the time for reviewing instructions, searching existing data sources, gathering and maintaining the data needed, and completing and reviewing the collection of information. Send comments regarding this burden estimate or any other aspect of this collection of information, including suggestions for reducing this burden, to Washington Headquarters Services, Directorate for Information Operations and Reports, 1215 Jefferson Davis Highway, Suite 1204, Arlington, VA 22202-4302, and to the Office of Management and Budget, Paperwork Reduction Project (0704-0188), Washington, DC 20503. | | | | |
| 1. AGENCY USE ONLY (Leave Blank) | 2. REPORT DATE April 2004 | 3. REPORT TYPE AND DATES COVERED NASA Technical Paper | | |
| 4. TITLE AND SUBTITLE Advanced EVA Capabilities: A Study for NASA's Revolutionary Aerospace Systems Concept Program | | | 5. FUNDING NUMBERS | |
| 6. AUTHOR(S) Stephen J. Hoffman, Ph.D.* | | | | |
| 7. PERFORMING ORGANIZATION NAME(S) AND ADDRESS(ES) Lyndon B. Johnson Space Center Houston, Texas 77058 | | | 8. PERFORMING ORGANIZATION REPORT NUMBERS S-922 | |
| 9. SPONSORING/MONITORING AGENCY NAME(S) AND ADDRESS(ES) National Aeronautics and Space Administration Washington, DC 20546-0001 | | | 10. SPONSORING/MONITORING AGENCY REPORT NUMBER TP-2004-212068 | |
| 11. SUPPLEMENTARY NOTES *Science Applications International Corporation, Houston, Texas | | | | |
| 12a. DISTRIBUTION/AVAILABILITY STATEMENT Unclassified/Unlimited Available from the NASA Center for AeroSpace Information (CASI) 7121 Standard Hanover, MD 21076-1320 Subject Category 54 | | | 12b. DISTRIBUTION CODE | |
| 13. ABSTRACT (Maximum 200 words) This report documents the results of a study carried out as part of NASA's Revolutionary Aerospace Systems Concepts Program examining the future technology needs of extravehicular activities (EVAs). The intent of this study is to produce a comprehensive report that identifies various design concepts for human-related advanced EVA systems necessary to achieve the goals of supporting future space exploration and development customers in free space and on planetary surfaces for space missions in the post-2020 timeframe. The design concepts studied and evaluated are not limited to anthropomorphic space suits, but include a wide range of human-enhancing EVA technologies as well as consideration of coordination and integration with advanced robotics. The goal of the study effort is to establish a baseline technology "road map" that identifies and describes an investment and technical development strategy, including recommendations that will lead to future enhanced synergistic human/robot EVA operations. The eventual use of this study effort is to focus evolving performance capabilities of various EVA system elements toward the goal of providing high-performance human operational capabilities for a multitude of future space applications and destinations. The data collected for this study indicate a rich and diverse history of systems that have been developed to perform a variety of EVA tasks, indicating what is possible. However, the data gathered for this study also indicate a paucity of new concepts and technologies for advanced EVA missions - at least any that researchers are willing to discuss in this type of forum. | | | | |
| 14. SUBJECT TERMS extravehicular activity, EVA, space suit, | | | 15. NUMBER OF PAGES 172 | 16. PRICE CODE |
| 17. SECURITY CLASSIFICATION OF REPORT Unclassified | 18. SECURITY CLASSIFICATION OF THIS PAGE Unclassified | 19. SECURITY CLASSIFICATION OF ABSTRACT Unclassified | 20. LIMITATION OF ABSTRACT Unlimited | |
