

Advantages and Disadvantages of Different Concepts of Electroporation Pulse Generation

UDK 621.374.3:57
IFAC 1.2.2

Review

Electroporator is a generator of electric pulses that is used for permeabilization of cells. There are five major concepts of electroporation design. Capacitor discharge, square wave generator, and analog generator are used to generate classical electroporation pulses that are longer than microsecond and pulse forming network, and resonant charging generator that are used to generate nanosecond electroporation pulses. The choice of an electroporator design is always driven by the biotechnological or biomedical application. Electroporators can be used for introduction of small (electrochemotherapy) and large molecules (gene electrotransfer), cell fusion, insertion of proteins into cell membrane, electroporation of organelles, pasteurization, tissue ablation etc. Basic concepts and foreseeable future developments in electroporator design are presented in this article.

Key words: Analog generator, Blumlein generator, Diode opening switch generator, Electroporator

Prednosti i nedostaci različitih pristupa generiranja impulsa za elektroporaciju. Elektroporator je generator impulsa koji se koristi za permeabilizaciju stanica. Postoji pet glavnih izvedbi elektroporatora. Pražnjenje kondenzatora, generator pravokutnog valnog oblika i analogni generator se koriste za klasične elektroporacijske impulse koji su duži od mikrosekunde, a mreža za formiranje impulsa i generator s rezonantnim nabijanjem se primjenjuju za generiranje nanosekundnih elektroporacijskih impulsa. Izbor izvedbe elektroporatora vođen je uvijek biotehnoškom ili biomedicinskom primjenom. Elektroporatori se mogu koristiti za ubacivanje malih (elektrokemoterapija) i velikih molekula (elektro genski prijenos), fuziju stanica, umetanje proteina u staničnu membranu, elektroporaciju organela, pasterizaciju, ablaciju tkiva itd. U radu su prikazani temeljni pristupi u izvedbama elektroporatora i predvidivi budući razvoj.

Ključne riječi: analogni generator, Blumlein generator, generator s diodnom sklopkom, elektroporator

1 INTRODUCTION

Electroporation is a phenomenon that occurs in membrane when it is exposed to sufficiently high electric field [1,2]. Efficacy of electroporation depends on many physical and biological parameters. These parameters can be divided into parameters of the electric field [3,4] and cell parameters that define the state of cells, their surrounding and cell geometry [5,6]. In electroporation applications we usually control and adjust electric field parameters to specific cell parameters and biotechnological or biomedical applications i.e. electroporation objectives. Nevertheless, some of the parameters are more significant than others. For example, it is very important to adjust pulse amplitude to specific cell size and pulse duration to specific objective. Although, this adjustment is not simple, as the electric field parameters are interrelated to some extent regarding the electroporation efficacy, i.e. the same level of electroporation can be obtained with E_1T_1 or E_2T_2 where E is electric field intensity, T pulse duration, $E_1 > E_2$

and $T_1 < T_2$ [7]. However, when pulse duration is in a nanosecond range the electric field penetrates into the cell interior and the voltage is induced also on the cells inner membranes [8]. Therefore, with very short and very high electric field pulses it is possible to electroporate also the cells internal membranes/organelles [9].

Electroporation can be used as reversible or irreversible, where reversibility/irreversibility is related to cell survival/death. Reversible electroporation can be further optimized for introduction of small and large molecules [10], fusion of cells [11] and insertion of proteins into cell membrane [12]. At this optimization auxiliary pulses are sometimes used such as electrophoretic pulses for DNA and di-electrophoretic pulses for cell fusion/pearl chain generation. Nowadays electroporation is widely used in various biological, medical, and biotechnological applications [13]. Destructive applications relying on irreversible electroporation although already described in 1960s are in the last decade getting increasing attention, but their effi-

cacy is promising especially in the field of water treatment where efficacy of chemical treatment is enhanced by electroporation, in food preservation where electroporation has proven, in some cases, to be as effective as pasteurization or in tissue ablation [14]. In contrast, applications based on reversible electroporation are currently more widespread and established in different experimental and clinical protocols. Probably the most important of them are the electrochemotherapy [15] and the gene electrotransfer [16].

Electroporation pulses that are used in electroporation research are with amplitudes from several mV to several kV and with frequency content from Hz to a few GHz Table 1 [17]. It is not possible to generate such wide spectrum of parameters with a single device. Therefore, before designing or purchasing an electroporator it is important to know for what application the electroporator will be used. For example, for some applications a very simple electroporator is sufficient. However, gene electrotransfer and cell electrofusion require also auxiliary signals, such as electrophoretic and dielectrophoretic signals, multi needle electrodes require electrode commutator, electroporation of organelles require very short pulses and for clinical applications compliance with clinical safety standards is required. Single cell electroporation or electroporation of planar lipid bilayer require low voltage electroporation pulses [18]. Electroporation of cells *in vitro* and *in vivo* require high voltage pulses. However, electroporation of organelles, bacteria or yeasts require even higher voltage.

Table 1. Pulse Parameters for Different Electroporation Applications

Application	Amplitude	Duration	Auxiliary Pulses
Electrochemotherapy	~ kV	μs , usually $8 \times 100 \mu\text{s}$	-
Gene electrotransfer	~ kV	μs - ms	Electrophoretic pulses $< 500 \text{ V}$, $> \text{ms}$
Electroinsertion	$< \text{kV}$	ms - s	-
Transdermal drug delivery	$< \text{kV}$	ms	-
Electrofusion	~ kV	μs	Dielectrophoretic pulses $< 200 \text{ V}$, $> \text{s}$, $\sim \text{MHz}$
Pasteurization	$\gg \text{kV}$	μs	-
Tissue ablation	$> \text{kV}$	μs - ms	-
Single cell electroporation	$> \text{mV}$	μs	-
Organelle electroporation	$\gg \text{kV}$	ns	-
Electroporation research	mV- kV	ns - s	-

2 ELECTROPORATOR DESIGN

There are at least five major concepts of electroporation design. Three to generate electroporation pulses longer than $1 \mu\text{s}$ and two to generate electroporation pulses shorter than $1 \mu\text{s}$. Pulses longer than $1 \mu\text{s}$ are usually generated by a capacitor discharge, square wave generator or an analog generator [19-22]. Pulses shorter than $1 \mu\text{s}$ are usually generated by pulse forming networks or resonant charging generators [23-25]. As a pulse forming network generator a Blumlein generator will be described and as a resonant charging generator a diode opening switch generator will be described. However, there are other major concepts and some of them are described in detail elsewhere [26-28]. Electroporators can also be divided into three groups regarding the amplitude of the output signal and the switching elements that are used at the output of the generator. The group that generates output voltages up to a few V usually uses operational amplifiers to generate electroporation pulses. The group that generates output voltages from a few V up to a few kV usually uses transistors to generate electroporation pulses. And the group that generates output voltages higher than a few kV usually uses spark gaps to generate electroporation pulses.

Patient and operator safety is mainly ensured by minimizing the leakage currents. The leakage current in the electroporator is minimized by galvanic separation of the electroporator output and the ground. The separation can be made in the power supply circuit or at the output of the electroporator. However, as the insulation transformers deform the pulses, the separation is usually made in the power supply circuit [29].

2.1 Capacitor discharge

This is the oldest concept of electroporation pulse generation primarily used *in vitro* but also *in vivo* [2,30]. The concept comprises a variable high voltage power supply V , a capacitor C , a switch S and optionally a resistor R Fig. 1.

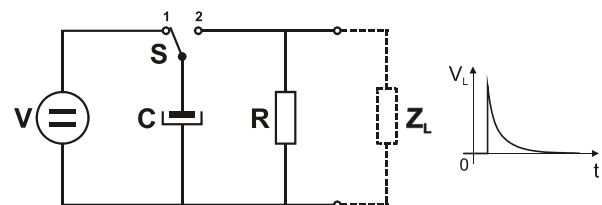

Fig. 1. Capacitor discharge circuit for generation of exponentially decaying electroporation pulses

The generator operates in two phases, charge and discharge, and generates exponentially decaying pulses. During the charge phase, the switch S is in the position 1 and variable high voltage power supply V charges the capacitor C to the preset voltage. In the discharge phase, the

switch is in the position 2, and the capacitor discharges through the load connected to the output. Time constant of discharge τ can be approximated by product $Z_L C$, where C is the capacitance of capacitor and Z_L is the absolute value of the load impedance. However, the impedance of biological load reduces during the pulse delivery [31]. This also means that the time constant changes during the pulse. Therefore, most commercially available capacitor discharge-based electroporators have built-in resistances that are connected in parallel to the load. Their main purpose is to better define the time constant of the discharge. Namely, if an additional resistor is connected in parallel to the load, the time constant of discharge is defined by: $(R||Z_L) C$, where R is resistance of the internal resistors. If absolute value of the impedance of load Z_L is at least 10 times larger than the resistance R , the time constant can be approximated by the RC product (1).

$$(R||Z_L) C = \left(\frac{RZ_L}{R + Z_L} \right) C = \left(\frac{10R^2}{11R} \right) C \approx RC; \\ Z_L = 10R \quad (1)$$

The presented capacitor discharge concept is very simple and inexpensive for construction. By using spark gaps for the switch S the output amplitudes can reach several kV and a few kA. The exponentially decaying pulse generated can be used even for gene transfection as it includes the high voltage part for permeabilization and low voltage electrophoretic part [32,33]. However, the flexibility of such high-low voltage pulse composition is rather poor, as the electrical parameters of the high voltage part cannot be changed without affecting the low voltage part and vice versa. Moreover, the low voltage part is usually undesired in other electroporation applications, as it greatly affects the cell viability [34]. Also, the repetition frequency of such pulse generation is low due to relatively long charge phase.

2.2 Square wave pulse generators

For better control of electric field parameters, square wave pulse generators have been introduced [35,36]. The concept is similar to the capacitor discharge concept; except that the voltage power supply V constantly charges the capacitor C and that the power switch S is capable of fast switching (Fig. 2).

Usually, fast power MOSFET (metal oxide silicon field effect transistor) or IGBT (insulated gate bipolar transistor) are used as the switch. The output amplitude of the pulse is defined by the amplitude of the variable power supply V , while pulse duration, pulse repetition frequency and possibly number of pulses are defined by the switching sequence of the fast power switch S . As the switching sequence is faster and more complex, also the control unit of the gener-

ator must be faster and more complex than for the capacitor discharge generator.

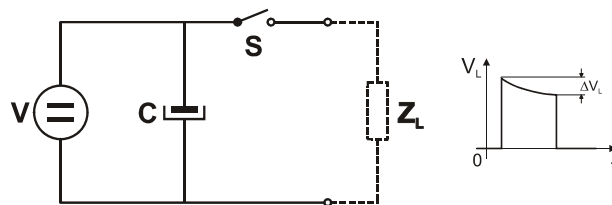

Fig. 2. High voltage power supply switching circuit for generation of square wave electroporation pulses

Despite improved control over the electric field parameters, this concept still has drawbacks that limit flexibility and accuracy of pulse parameters available to the user. The main problem is that electroporation pulses are with high power but very short. Thus, a power supply cannot generate the energy for the pulse during the pulse generation, but it has to be generated and stored into the capacitor before the generation of the pulse. This usually results in voltage drop ΔV_L during the pulse (2),

$$\Delta V_L \propto \frac{t_P}{C \cdot Z_L} \quad (2)$$

where t_P is the duration of the pulse. In order to minimize this voltage drop a very large capacitance is needed. However as a consequence of a very large capacitance it is now harder to change the amplitude between the pulses. Therefore, square wave pulse generators usually generate pulses with only one (preset) voltage. Nevertheless, at very high loads (very high current flow) voltage on the capacitor will inevitably decrease during the pulse generation. As it is usually required that each pulse has the same amplitude as the first one that was generated, next pulse can only be delivered after the capacitor is recharged to the preset voltage. Therefore, limitation of power supply also defines the highest pulse repetition frequency. By using MOSFETs or IGBTs for the switch S the output amplitudes can reach a few kV and several A [29]. However, if capacitor C is replaced by pulse forming network and spark gap is used for the switch S the output amplitudes can reach several kV and a few kA.

Modular square wave pulse generator was designed to improve output amplitude flexibility of the square wave pulse generator [37,38]. It consists of several square wave pulse generators connected in series (Fig. 3). The generators have galvanically isolated high voltage power supplies $V_{1,2...N}$. Each square wave pulse generator is controlled individually and can be set to different amplitude than other generators. The voltage of the individual generator is constant and can contribute to the generation of a

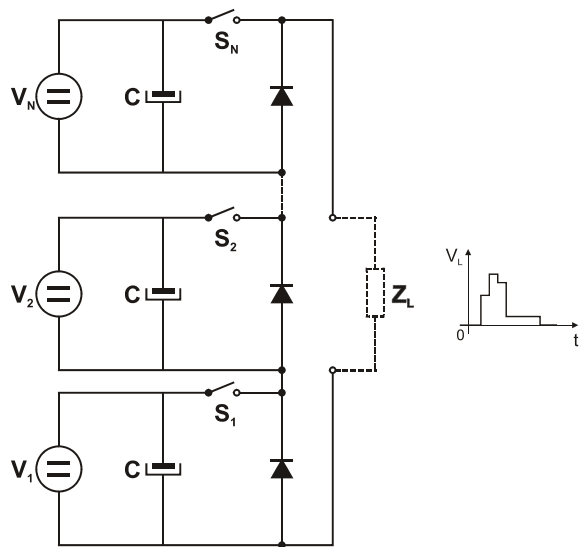

Fig. 3. Modular square wave pulse generator

common output pulse V_L at any time. Although the design of each individual source is similar to the design of previously described square wave pulse generator, the individual power supply $V_{1,2,\dots,N}$ used in this concept has constant (not variable) output voltage. As a constant voltage power supplies do not discharge during the pulse delivery, they are simpler to be designed to sustain the maximum possible current during the pulse generation. In this way, the output amplitude does not decrease during the pulse delivery.

The presented modular concept can generate well defined pulses as its rise and fall times are fast and the amplitude is stable. However, to have enough output voltage levels many square wave pulse generators are needed (depending on “voltage” steps/resolution), which consequently increases the cost of the device.

2.3 Analog generators

Although square wave and exponentially decaying pulses were and probably still are the most frequently used signals for electroporation, analog generators have definitely some advantages over them. The concept of analog generators was introduced to generate arbitrary shaped electroporation pulses and to improve output amplitude stability of the square wave pulse generator [39-41]. The concept comprises of variable high voltage power supply V , capacitor C , signal generator F_G , linear switch Q and voltage divider R_1 and R_2 (Fig. 4).

Energy for the pulse is stored in the capacitor C by setting the power supply voltage V higher than the maximal generated amplitude. Therefore, lower capacitance is

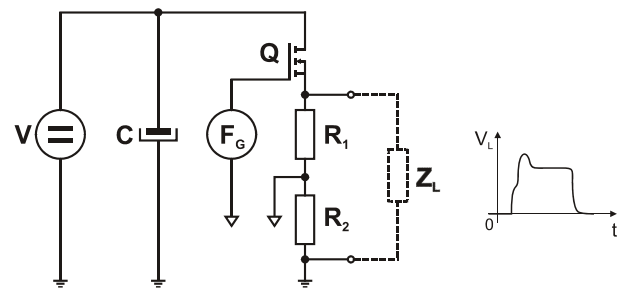

Fig. 4. Analog generator for generation of arbitrary electroporation pulses

needed to store the energy for the pulse and the amplitude of the pulse will not drop during the pulse generation, unless the capacitor voltage drops below the expected output amplitude. Usually, the preset voltage is at least 10% or 50 V higher than the maximal generated amplitude V_L .

The pulse shape is first generated by the signal generator F_G , which is usually a computer with a digital to analog (D/A) converter. This signal is then amplified by a linear switch Q . Usually, an amplifier with common source and galvanically separated input is used, as it is non-inverting voltage and current amplifier. This amplifier needs a galvanic separation between the driving and the power supply circuit. This however is definitely not a drawback, as all electroporators should have galvanically isolated output for safety reasons. The linear amplifier consists of a linear switch (usually MOSFET or IGBT) and voltage divider R_1 and R_2 . Voltage divider is used as a feedback for regulation of the output amplitude. The signal, reduced for a voltage threshold of the linear amplifier, is therefore amplified by factor $(R_1 + R_2) / R_1$. If the current amplification in this stage is not high enough, a current amplifier (common source) can be added to the output.

This design allows wide flexibility of all electrical parameters and electroporation control [42], yet some drawbacks still exist. The driving stage is much more complex than in other described electroporators and the rise and fall times of the pulses cannot be as fast as with square wave pulse generator. Nevertheless, the major drawback of this concept is a safe operation area (SOA; voltage, current, power and energy limitations) of linear transistors. Therefore, the duration, voltage and current of the pulse are limited as there is high power dissipation when transistor is working in its linear area. As the spark gaps cannot be used in this concept the output amplitudes cannot be higher than a few kV and several A. Square or analog generators can also be designed to generate bipolar pulses by means of push-pull or full bridge amplifier [43-46]. However for push-pull generators current between the pulses (zero driving voltage) has to be taken care of.

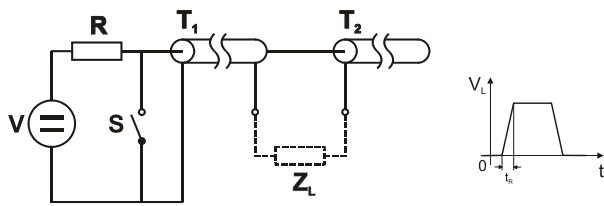

Fig. 5. Blumlein generator for generation of square wave nanosecond electroporation pulses

2.4 Blumlein generators

This is the oldest concept of high voltage nanosecond pulse generation primarily used in radar systems and recently also for electroporation [47,48]. The concept comprises a variable high voltage power supply V , a charging resistor R , two transmission lines T_1 and T_2 , and a switch S (Fig. 5).

The generator operates in two phases, charge and discharge, and generates square wave pulses. During the charge phase, the switch S is turned off and variable high voltage power supply V charges the transmission lines T_1 and T_2 to the preset voltage. In the discharge phase, the switch is turned on, and the transmission lines are discharged through the load connected to the output. To generate square wave pulse without any pulse reflections, the impedance of the load has to be twice the impedance of the transmission line. In this case the duration of the pulse equals twice the electrical length of the transmission line and the amplitude of the pulse equals to the preset voltage V . However, the impedance of biological load reduces during the pulse delivery. If the impedance reduction is substantial it is very convenient to use a resistor in parallel to the main load Z_L as in chapter 2.1.

The presented Blumlein generator has a very simple architecture but has high demands for the electrical components. The switching element has to withstand full high voltage and has to have considerable shorter rise time t_R than the duration of the nanosecond pulse. By using spark gaps as the switch S the output amplitudes can reach several kV and a few kA. Blumlein generator is considered as inflexible in electrical output parameters however with the latest modifications it can generate high frequency output pulse with variable duration, amplitude and polarity [48-50].

2.5 Diode opening switch generators

Although the Blumlein generators were and probably still are the most frequently used generators for intracellular electroporation, diode opening switch generators have definitely some advantages over them. The concept comprises a variable high voltage power supply V , a charging

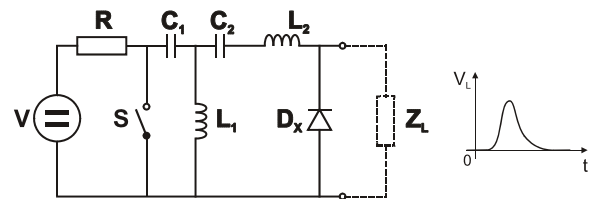

Fig. 6. Diode opening switch generator for generation of nanosecond electroporation pulses similar to Gaussian function

resistor R , a switch S , an LC oscillator L_1 , L_2 , C_1 and C_2 , and a stack of diodes D_X (Fig. 6).

The generator operates in two phases, charge and discharge, and generates pulses similar to Gaussian function [51]. During the charge phase, the switch S is turned off and variable high voltage power supply V charges the capacitor C_1 over charging resistor R to the preset voltage. In the discharge phase, the switch is turned on, and the LC oscillator starts to oscillate. The pulse on the load is formed by a diode stack D_X that rapidly interrupts the current of the oscillator in the third quarter of the period and commutates it into the load resistance Z_L . The circuit of the diode opening switch pulse generator is designed so that the reverse current in the diode is much higher than the forward current and that the depleting of the stored charge ends at the highest reverse current. Thus the commutated current is very high as well as the induced voltage on the load. To get even higher commutated current saturable-core inductors are used in LC oscillator instead of air-core inductors [52]. However, when saturable-core inductors are used the output amplitude cannot be set linearly as in the case when air-core inductors are used.

The advantage of the diode opening switch generators in comparison to Blumlein generators is that the electrical components are more accessible because the power supply does not generate the full output amplitude and the switch does not need to withstand the whole output amplitude and does not need to be faster than the output pulse. However, the design of the diode opening switch generator is much more complicated than the design of the Blumlein generator. The output amplitudes of the diode opening switch generator can reach several kV and several A.

3 CONCLUSION

The choice of an electroporator design is always driven by the application. This defines the requirements for electric pulse parameters (i.e. pulse amplitude, pulse duration, number of pulses, pulse repetition rate, pulse shape, etc). However, for molecular cell biology research it is very useful to have wide range, flexibility and control over pulse

parameters though such electroporators are expensive and not easy to obtain. Usually the interesting results start where the parameters available are out of range. For specific application however the choice in principle is easier as the pulse parameters have been optimized before; the load is well characterized and so the range of parameters is narrowed. Advantages and disadvantages of different concepts of electroporation pulse generation are summarized in Table 2.

Table 2. Summary of advantages and disadvantages of different concepts of electroporation pulse generation

Concept	Advantages	Disadvantages
Capacitor discharge	Simple and inexpensive construction Simple control system High voltages	Poor flexibility and control of parameters Low cell survival
Square wave pulse generators	Simple control system High currents Good control and flexibility of time parameters	Amplitude drop during the pulse Low amplitude flexibility
Analog generators	Wide flexibility of pulse parameters Arbitrary signal shape Electroporation control	Complex control system Limitation of power dissipation
Blumlein generators	Simple design High voltages and currents Possible variable duration and polarity	Complex switching element Required impedance matching
Diode opening switch generators	Accessible electrical components Variability of the load impedance	Complicated design Low output power

In the future, as in the past, the researchers will try to break the borders of possible. They will try to make shorter and shorter electroporation pulses and use special antennas to apply the pulses to biological load. They might succeed in targeting the tumour inside the body or get some data that might help to resolve how electroporation starts/occurs. Some will try to push over the limits other electric pulse parameters of nanosecond pulses like pulse repetition rate. This parameter is known to improve electroporation and it might also explain one of many mysteries of electroporation. On the other hand researchers that are more interested in the electroporation applications especially in gene electrotransfer will try to combine the nanosecond and classical micro- and millisecond electroporation pulses to achieve higher gene transfection yield.

Finally with new electronic elements higher output voltages will be achieved and higher currents through the loads enabled; and if it will not be possible to treat the whole sample because of its size, we will always find ways how to develop a batch or flow process, and divide the volume into smaller fractions.

ACKNOWLEDGMENT

The authors want to thank Slovenian Research Agency (ARRS) and European Commission for their support through various grants.

REFERENCES

- [1] J. Teissie, M. Golzio, and M. P. Rols, "Mechanisms of cell membrane electropermeabilization: A minireview of our present (lack of ?) knowledge," *Biochimica Et Biophysica Acta-General Subjects*, vol. 1724, no. 3, pp. 270-280, Aug, 2005.
- [2] E. Neumann, and Rosenhec.K, "Permeability Changes Induced By Electric Impulses In Vesicular Membranes," *Journal of Membrane Biology*, vol. 10, no. 3-4, pp. 279-290, 1972.
- [3] K. Flisar, M. Puc, T. Kotnik et al., "Cell membrane electropermeabilization with arbitrary pulse waveforms," *IEEE Engineering in Medicine and Biology Magazine*, vol. 22, no. 1, pp. 77-81, Jan-Feb, 2003.
- [4] M. Rebersek, C. Faurie, M. Kanduser et al., "Electroporator with automatic change of electric field direction improves gene electrotransfer in-vitro," *Biomedical Engineering Online*, vol. 6, Jul, 2007.
- [5] G. Pucihar, T. Kotnik, M. Kanduser et al., "The influence of medium conductivity on electropermeabilization and survival of cells in vitro," *Bioelectrochemistry*, vol. 54, no. 2, pp. 107-115, Nov, 2001.
- [6] M. Golzio, M. P. Mora, C. Raynaud et al., "Control by osmotic pressure of voltage-induced permeabilization and gene transfer in mammalian cells," *Biophysical Journal*, vol. 74, no. 6, pp. 3015-3022, Jun, 1998.
- [7] D. Miklavcic, G. Pucihar, A. Macek Lebar et al., "The pulse intensity-duration dependency for cell membrane electroporation," *Advanced Electroporation Techniques in Biology and Medicine*, A. G. Pakhomov, D. Miklavcic and M. S. Markov, eds., pp. 239-251: CRC, Boca Raton, USA, 2010.
- [8] T. Kotnik, and D. Miklavcic, "Theoretical evaluation of voltage inducement on internal membranes of biological cells exposed to electric fields," *Biophysical Journal*, vol. 90, no. 2, pp. 480-491, Jan, 2006.
- [9] T. Batista Napotnik, M. Rebersek, T. Kotnik et al., "Electropermeabilization of endocytotic vesicles in B16 F1 mouse melanoma cells," *Medical & Biological Engineering & Computing*, vol. 48, no. 5, pp. 407-413, May, 2010.
- [10] L. M. Mir, "Therapeutic perspectives of in vivo cell electropermeabilization," *Bioelectrochemistry*, vol. 53, no. 1, pp. 1-10, Jan, 2001.
- [11] K. Trontelj, M. Rebersek, M. Kanduser et al., "Optimization of bulk cell electrofusion in vitro for production of human-mouse heterohybridoma cells," *Bioelectrochemistry*, vol. 74, no. 1, pp. 124-129, Nov, 2008.

- [12] Y. Mouneimne, P. F. Tosi, Y. Gazitt et al., "Electro-Insertion Of Xeno-Glycophorin Into The Red Blood-Cell Membrane," *Biochemical and Biophysical Research Communications*, vol. 159, no. 1, pp. 34-40, Feb, 1989.
- [13] M. Kanduser, and D. Miklavcic, "Electroporation in biological cell and tissue: an overview," *Electrotechnologies for Extraction from Food Plants and Biomaterials*, E. Vorobiev and N. Lebovka, eds., pp. 1-37, New York: Springer Science, 2008.
- [14] M. Hjouj, and B. Rubinsky, "Magnetic Resonance Imaging Characteristics of Nonthermal Irreversible Electroporation in Vegetable Tissue," *Journal of Membrane Biology*, vol. 236, no. 1, pp. 137-146, Jul, 2010.
- [15] L. M. Mir, J. Gehl, G. Sersa et al., "Standard operating procedures of the electrochemotherapy: Instructions for the use of bleomycin or cisplatin administered either systemically or locally and electric pulses delivered by the Cliniporator (TM) by means of invasive or non-invasive electrodes," *Ejc Supplements*, vol. 4, no. 11, pp. 14-25, Nov, 2006.
- [16] L. M. Mir, "Nucleic Acids Electrotransfer-Based Gene Therapy (Electrogenetherapy): Past, Current, and Future," *Molecular Biotechnology*, vol. 43, no. 2, pp. 167-176, Oct, 2009.
- [17] M. Rebersek, and D. Miklavcic, "Concepts of Electroporation Pulse Generation and Overview of Electric Pulse Generators for Cell and Tissue Electroporation," *Advanced Electroporation Techniques in Biology and Medicine*, A. G. Pakhomov, D. Miklavcic and M. S. Markov, eds., pp. 323-339: CRC, Boca Raton, USA, 2010.
- [18] P. Kramar, D. Miklavcic, and A. M. Lebar, "A System for the Determination of Planar Lipid Bilayer Breakdown Voltage and Its Applications," *IEEE Transactions on Nanobiotechnology*, vol. 8, no. 2, pp. 132-138, Jun, 2009.
- [19] A. J. H. Sale, and W. A. Hamilton, "Effects of high electric fields on microorganisms. I. Killing of bacteria and yeasts," *Biochimica et Biophysica Acta - Biomembranes*, vol. 148, no. 3, pp. 781-788, Dec, 1967.
- [20] H. Potter, "Electroporation in biology: Methods, applications, and instrumentation," *Analytical Biochemistry*, vol. 174, no. 2, pp. 361-373, Nov, 1988.
- [21] L. DeFrancesco, "Shock jocks," *Scientist*, vol. 11, no. 15, pp. 19-21, 1997.
- [22] B. M. Chassy, J. A. Saunders, and A. E. Sowers, "Pulse generators for electrofusion and electroporation," *Guide to Electroporation and Electrofusion*, Eds. D. C. Chang, B. M. Chassy, J. A. Saunders, and A. E. Sowers, New York: Academic, 1992.
- [23] A. D. Blumlein, "Improvements in or relating to apparatus for generating electrical impulses," GB Patent 589127, 1947.
- [24] R. Nuccitelli, U. Pliquett, X. H. Chen, et al. "Nanosecond pulsed electric fields cause melanomas to self-destruct," *Biochemical and Biophysical Research Communications*, vol. 343, no. 2, pp. 351-360, May, 2006.
- [25] F. Wang, A. Kuthi, and M. A. Gundersen, "Compact high repetition rate pseudospark pulse generator," *IEEE Transactions on Plasma Science*, Vol. 33, No. 4, pp. 1177-1181, Aug, 2005.
- [26] E. Marx, "Verfahren zur Schlagprüfung von Isolatoren und anderen elektrischen Vorrichtungen," German Patent 455933, 1923.
- [27] M. Sack, C. Schultheiss, and H. Bluhm, "Triggered Marx Generators for the Industrial-Scale Electroporation of Sugar Beets," *IEEE transactions on industry applications*, vol. 41, no. 3, pp. 707-714, Jun, 2005.
- [28] S. N. Rukin, "High-Power Nanosecond Pulse Generators Based on Semiconductor Opening Switches," *Instruments and Experimental Techniques*, Vol. 42, No. 4, pp. 439-467, 1999.
- [29] C. Bertacchini, P. M. Margotti, E. Bergamini et al., "Design of an irreversible Electroporation system for clinical use," *Technology in Cancer Research & Treatment*, vol. 6, no. 4, pp. 313-320, Aug, 2007.
- [30] M. Okino, and H. Mohri, "Effects Of A High-Voltage Electrical Impulse And An Anticancer Drug On Invivo Growing Tumors," *Japanese Journal of Cancer Research*, vol. 78, no. 12, pp. 1319-1321, Dec, 1987.
- [31] M. Pavlin, M. Kanduser, M. Rebersek et al., "Effect of cell electroporation on the conductivity of a cell suspension," *Biophysical Journal*, vol. 88, no. 6, pp. 4378-4390, Jun, 2005.
- [32] M. Kanduser, D. Miklavcic, and M. Pavlin, "Mechanisms involved in gene electrotransfer using high- and low-voltage pulses - An in vitro study," *Bioelectrochemistry*, vol. 74, no. 2, pp. 265-271, Feb, 2009.
- [33] S. Satkauskas, M. F. Bureau, M. Puc et al., "Mechanisms of in vivo DNA electrotransfer: Respective contributions of cell electropermeabilization and DNA electrophoresis," *Molecular Therapy*, vol. 5, no. 2, pp. 133-140, Feb, 2002.
- [34] M. Danfelter, P. Engstrom, B. R. R. Persson et al., "Effect of high voltage pulses on survival of Chinese hamster V79 lung fibroblast cells," *Bioelectrochemistry and Bioenergetics*, vol. 47, no. 1, pp. 97-101, 1998.
- [35] M. Puc, K. Flisar, S. Rebersek et al., "Electroporator for in vitro cell permeabilization," *Radiol. Oncol.*, vol. 35, pp. 203-207, 2001.
- [36] M. Tokmakci, "A High-Voltage Pulse Generation Instrument for Electrochemotherapy Method," *J Med Syst*, vol. 30, pp. 145-151, 2006.
- [37] M. Petkovsek, J. Nastran, D. Voncina et al., "High voltage pulse generation," *Electronics Letters*, vol. 38, no. 14, pp. 680-682, Jul, 2002.
- [38] S. Bae, A. Kwasinski, M. M. Flynn et al., "High-Power Pulse Generator With Flexible Output Pattern," *IEEE Transactions on Power Electronics*, vol. 25, no. 7, pp. 1675-1684, Jul, 2010.

- [39] D.C. Chang, "Cell poration and cell fusion using an oscillating electric field," *Biophysical Journal*, vol. 56, no. 4, pp. 641-652, Oct, 1989.
- [40] V. Sharma, K. Stebe, J. C. Murphy et al., "Poloxamer 188 decreases susceptibility of artificial lipid membranes to electroporation," *Biophysical Journal*, vol. 71, no. 6, pp. 3229-3241, Dec, 1996.
- [41] T. Kotnik, G. Pucihar, M. Rebersek et al., "Role of pulse shape in cell membrane electropermeabilization," *Biochimica Et Biophysica Acta-Biomembranes*, vol. 1614, no. 2, pp. 193-200, Aug, 2003.
- [42] D. Cukjati, D. Batuskaite, F. Andre et al., "Real time electroporation control for accurate and safe in vivo non-viral gene therapy," *Bioelectrochemistry*, vol. 70, no. 2, pp. 501-507, May, 2007.
- [43] K. Flisar, M. Puc, T. Kotnik et al., "Cell membrane electropermeabilization with arbitrary pulse waveforms," *IEEE Engineering in Medicine and Biology*, vol. 22, no. 1, pp. 77-81, Jan, 2003.
- [44] E. Tekle, R. D. Astumian, and P. B. Chock, "Electroporation by using bipolar oscillating electric field: An improved method for DNA transfection of NIH 3T3 cells," *Proceedings of the National Academy of Sciences USA*, vol. 88, pp. 4230-4234, May, 1991.
- [45] S. A. Yakovenko, "Electroporators Based on Digital Formation of Arbitrarily-Shaped Electroporation Pulses," *Biomedical Instrumentation & Technology*, vol. 38, no. 5, pp. 397-409, Sep, 2004.
- [46] E. DeVuyst, M. DeBock, and E. Decrock, "In Situ Bipolar Electroporation for Localized Cell Loading with Reporter Dyes and Investigating Gap Junctional Coupling," *Biophysical Journal*, vol. 94, no. 2, pp. 469-479, Jan, 2008.
- [47] J. Deng, R. H. Stark, and K. H. Schoenbach, "A compact nanosecond pulse generator with water as dielectric and switch medium," *Pulsed Power Plasma Science*, vol. 2, pp. 1587-1590, 2001.
- [48] J. F. Kolb, S. Kono, and K. H. Schoenbach, "Nanosecond pulsed electric field generators for the study of subcellular effects," *Bioelectromagnetics*, vol. 27, no. 3, pp. 172-187, Apr, 2006.
- [49] A. De Angelis, J. F. Kolb, L. Zeni, et al., "Kilovolt Blumlein pulse generator with variable pulse duration and polarity," *Review of Scientific Instruments*, vol. 79, no. 4, pp. 1-4, 2008.
- [50] M. Rebersek, M. Kranjc, D. Pavliha et al., "Blumlein configuration for high-repetition-rate pulse generation of variable duration and polarity using synchronized switch control," *IEEE Transaction on Biomedical Engineering*, vol. 56, no. 11, pp. 2642-2648, 2009.
- [51] J. M. Sanders, A. Kuthi, Y. H. Wu et al., "A Linear, Single-stage, Nanosecond Pulse Generator for Delivering Intense Electric Fields to Biological Loads," *IEEE Transactions on Dielectrics and Electrical Insulation*, vol. 16, no. 4, pp. 1048-1054, Aug, 2009.
- [52] T. Tang, F. Wang, A. Kuthi et al., "Diode opening switch based nanosecond high voltage pulse generators for biological and medical applications," *IEEE Transactions on Dielectrics and Electrical Insulation*, vol. 14, no. 4, pp. 878-883, Aug, 2007.



Matej Reberšek was born in Ljubljana, Slovenia, in 1979. He received the Ph.D. degree in electrical engineering from the University of Ljubljana, Ljubljana. He is currently a Research Associate in the Laboratory of Biocybernetics, Faculty of Electrical Engineering, University of Ljubljana. His current research interests include electroporation, especially design of electroporation devices and investigation of biological responses to nanosecond electrical pulses.



Damijan Miklavčič was born in Ljubljana, Slovenia, in 1963. He received the Ph.D. degree in electrical engineering from the University of Ljubljana, Ljubljana. He is currently a Professor in the Faculty of Electrical Engineering, University of Ljubljana, where he is also the Head of the Laboratory of Biocybernetics. He is involved in the field of biomedical engineering. His current research interests include electroporation-assisted drug and gene delivery, including cancer treatment by means of electrochemotherapy, tissue oxygenation, and modeling.

AUTHORS' ADDRESSES

Matej Reberšek, Ph.D.

Prof. Damijan Miklavčič, Ph.D.

Laboratory of Biocybernetics,

University of Ljubljana,

Faculty of Electrical Engineering,

Tržaška 25, 1000, Ljubljana, Slovenia

emails: {matej.rebersek, damijan.miklavcic}@fe.uni-lj.si

Received: 2010-10-05

Accepted: 2011-02-16