

# ADVISOR-Based Model of a Battery and an Ultra-Capacitor Energy Source for Hybrid Electric Vehicles

Andrew C. Baisden, *Student Member, IEEE*, and Ali Emadi, *Senior Member, IEEE*

**Abstract**—An energy source is the heart of a hybrid electric vehicle. If it is capable of supplying enough power at all times, then it is an adequate source. Major problems presently facing the industry include the size, cost, and efficiency of the energy source. The primary energy source presently used in automotive systems is a battery. In order to reduce the cost of the battery, the current needs to be decreased and stabilized so it is not very erratic. The purpose of this paper is to introduce and justify the use of a new model for an energy source: a battery in parallel with an ultra-capacitor. The ultra-capacitor can supply a large burst of current, but cannot store much energy. Conversely, the battery can store mass amounts of energy; however, without expensive and inefficient units, a battery cannot provide the current that the ultra-capacitor can. By combining the two energy sources in parallel, the storage and peak current characteristics desired can be achieved. The standards of the vehicle are not degraded, allowing this to be a promising technique to incorporate into hybrid electric vehicles to reduce their cost and increase the efficiency of their energy-source system.

**Index Terms**—Electric drives, electric propulsion, energy source, hybrid electric vehicles, power electronic converters, ultra-capacitor, vehicle simulation.

## I. INTRODUCTION

THE desire to improve the fuel economy, emissions, and performance of vehicles has given rise to the advent of more electric vehicles (MEVs) and hybrid electric vehicles (HEVs) [1]. The proposed 42-V PowerNet system will allow for the electrical loads to increase and improve upon the efficiency of the vehicles [2]–[4]. The next generation of MEVs will be the HEVs; that is, implementing an electric motor to assist the internal combustion engine (ICE) for propulsion of the vehicle [5].

Designing an HEV is dependent upon the energy source that provides for all of the electrical loads. The energy source needs to have adequate storage to meet the demands that the vehicle may encounter under any condition [5]. In addition to the storage capacity, the source needs to be able to produce the required amounts of power; more specifically, peak power demands that will meet the demands of the electrical loads in the car. Present technology does not provide a device proficient of high storage capabilities and maximum power flow; there is a trade

TABLE I  
BATTERY VERSUS ULTRA-CAPACITOR PERFORMANCE [7]

Performance	Battery	Ultra-capacitor
Specific energy (storage)	10-100 $W-h/Kg$	5-10 $W-h/Kg$
Specific power (delivery)	<1000 $W/Kg$	<10,000 $W/Kg$
Charge/discharge efficiency	50-85%	85-98%
Life expectancy	3 years	10 years

off between the two. A battery, a well-known energy source, is capable of the mass storage of energy; however, it has a low power-output density. That is, a battery is incapable of supplying a large request of power in a short time. The power required to supply the needed demands of the vehicle necessitates a very expensive and inefficient battery relative to other batteries. Therefore, if it is possible to use a smaller battery with less peak-output power, the cost would decrease and efficiency of the energy source would increase [6]. Another source available is an ultra-capacitor. The ultra-capacitor has little storage; however, it can supply a large burst of power. If the benefits of the battery and ultra-capacitor can be harnessed together, then the storage and power-flow requirements can be met. As Table I explains, the battery provides the storage of energy while an ultra-capacitor supplies the peak power demands [7]. In addition, the efficiency of the ultra-capacitor will be exploited to further improve upon the overall energy source. A vital criterion of the new energy source is that the characteristics of the battery and ultra-capacitor need to be combined without degrading the performance standards of a vehicle [1]. By connecting the two energy sources together in a parallel configuration, the benefits of both can be achieved as a complete energy source [8].

In this paper, the effects of combining the two energy sources—a battery and an ultra-capacitor—are studied. In Section II, the model used is given. It is created in a vehicle-simulation software and the control strategies of the two energy sources are explained. The analysis process of testing the new source is discussed in Section III. Sections IV and V provide and explain the results of the simulations. The simulations provide a detailed breakdown of the two energy sources, when the sources are separate and combined for an accurate comparison. In Section IV, the current through the energy source and the savings are provided, whereas Section V discusses the performance of the proposed source compared to other systems. Finally, Section VI provides conclusions based on the findings.

Manuscript received May 26, 2003; revised August 27, 2003, September 28, 2003, and October 3, 2003.

A. C. Baisden is with the Center for Power Electronics Systems (CPES), Virginia Polytechnic Institute and State University, Blacksburg, VA 24061 USA.

A. Emadi is with the Illinois Institute of Technology, Chicago, IL 60616-3793 USA (e-mail: emadi@iit.edu).

Digital Object Identifier 10.1109/TVT.2003.822004

TABLE II  
MODES OF OPERATION OF THE DC/DC CONVERTER

Mode	Power Source	Load	Operation	Brief Explanation of Operation
I	Battery & Ultra-capacitor	Motor	Boost of Power	Capacitor supplies power up to the limits of the converter. Battery supplies the rest of the power needed.
II	Battery	Ultra-capacitor & Motor	Lower Motor Demands	Demands of the electrical loads are low so the battery can supply power to the motor and charge the capacitor if needed.
III	Motor (Generator)	Ultra-capacitor & Battery	Regeneration	Capacitor charges until full and battery take whatever power is left, or until regeneration is over with.

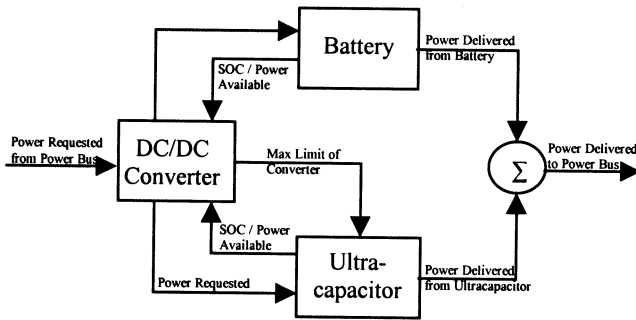

Fig. 1. Block diagram model programmed in Simulink.

## II. ENERGY-SOURCE MODEL

Due to extreme complexities in calculations of the parameters needed for an actual simulation of the parallel combination of the battery and ultra-capacitor, the advanced vehicle simulator (ADVISOR) is used [9]. ADVISOR works in a Matlab/Simulink environment; modeling the new energy source in ADVISOR provides a method to test the hypothesis in a practical situation. The dc/dc converter has to be modeled according to its appropriate operating modes. Table II summarizes the three basic modes that the parallel energy source can operate. The basic block diagram that is implemented in Simulink is shown in Fig. 1. In general, both the battery and capacitor can be charging or discharging at the same time; in addition, the battery can discharge supplying power to the motor and capacitor [8]. It is difficult to determine a proper control strategy for the energy source; that is, establishing the exact time to switch between the modes of operation to achieve optimal results. To begin, a very simple method for the converter is implemented. As results are gathered, a more specific and realistic model will be put into operation.

The control strategy (CS) used for the battery is to maintain the state of charge (SoC) between 60%–70% of its maximum capacity based on ADVISOR's standard for a parallel drivetrain. This standard is tested through simulations to be an adequate assumption for the battery; likewise, it is maintained throughout all simulations to allow for a proper comparison. The SoC is calculated by ADVISOR according to the characteristics of the energy source. The peak power and energy available from the source is also calculated by ADVISOR, which are dependent upon the SoC of the unit. The battery's CS is implemented through ADVISOR [9], [10]. The ultra-capacitor, however, is primarily controlled through the dc/dc converter shown in Fig. 1. The converter receives a demand for power from the vehicle, either positive to ask

TABLE III  
FRACTION OF CHARGING POWER SENT TO THE BATTERY AT VARIOUS BATTERY AND ULTRA-CAPACITOR SoCs

		Battery SoC			
		0.5	0.6	0.7	0.8
Ultra-capacitor SoC	0	0.5	0	0	0
	0.1	0.5	0	0	0
	0.2	0.5	0.1	0	0
	0.3	0.6	0.1	0	0
	0.4	0.75	0.1	0	0
	0.5	0.9	0.5	0	0
	0.6	1	0.75	0.1	0.25
	0.7	1	0.9	0.5	0.5
	0.8	1	0.9	0.75	0.75
	0.9	1	1	1	0.9
1.0	1	1	1	1	

TABLE IV  
 $K$  IS THE POWER REQUESTED IN WATTS FROM THE BATTERY AND POWER-REQUESTED  $K$  IS THE POWER REQUESTED FROM THE ULTRA-CAPACITOR AT VARIOUS ULTRA-CAPACITOR SoCs

Ultra-capacitor SoC	0	0.4	0.5	0.6	1
$K$ (W)	40,000	40,000	10,000	0	0

for power from the source or negative to supply regenerative power to the source. If the power demand is less than zero (mode III in Table II), the converter will proportionally send power to the battery and ultra-capacitor for charging relative to the SoC of each component. Table III shows the proportion of regenerative power sent to the battery at various battery and ultra-capacitor SoCs. As stated, under normal operating conditions, the battery's SoC will be between 0.6 and 0.7; however, the ultra-capacitor, due to its inherent operation of fully discharging to provide bursts of power, will operate over a much broader range of SoCs, as the table illustrates. For example, if the ultra-capacitor is below 50% of its maximum storage and the battery is in its normal operating range (60%–70%), then 90%–100% of the available regenerative charging power will be sent to charge the ultra-capacitor. Conversely, if the ultra-capacitor is fully charged, or close to it, then 100% of the available charging power will be sent to the battery. The table's values are produced experimentally through ADVISOR simulations to account for the different charging rates of the battery and ultra-capacitor.

Two modes have to be accounted for if the vehicle demands power from the energy source. To do this, a dynamic variable  $K$  is created. Table IV shows the value of  $K$  at different ultra-capacitor SoCs.  $K$  is defined as the power taken from the battery and the power taken from the ultra-capacitor is

the difference when  $K$  is subtracted from the vehicle's power request. The challenge of achieving maximum performance and fuel economy is achieved by changing this  $K$  variable, as illustrated. For instance, if  $K$  is kept lower (approximately 1000), then the fuel economy is improved. If  $K$  is increased, the fuel economy decreases; however, the performance, mainly grade ability and acceleration, will drastically improve. Therefore, having  $K$  increase as the ultra-capacitor SoC decreases allows for both maximum performance and fuel economy. With this arrangement, modes I and II in Table II can be achieved. If the power demand from the vehicle is greater than  $K$ , the converter is in mode I; likewise, if the demand is less than  $K$ , the converter is in mode II. Simulations are similarly conducted in ADVISOR to find  $K$ . In addition, both  $K$  and the values in Table III are linearly interpolated at other SoCs.

### III. DATA-COLLECTION PROCESS

Now that the parallel configuration of the battery and ultra-capacitor is correctly modeled in ADVISOR, the results can be gathered. In order to have a basis for comparison, a few preliminary simulations were run. Data for a conventional car and a parallel hybrid electric with only a battery source were obtained. The model for the battery-only parallel hybrid vehicle is the exact same as the proposed solution except that the energy source is only a battery, which is the standard model ADVISOR uses to simulate a parallel drivetrain hybrid. That is, the power demanded from the vehicle will only attempt to receive and provide power via the battery. With this information, the new model for the energy source can be compared with previous results. In addition, to justify that the results can all be evaluated properly, all simulations were run under the same conditions. All hybrid vehicles have a parallel drivetrain. Trials were run with a small car with a total power of 64 kW (86 hp). The hybridization factor (HF) is defined as the power of the electrical propulsion system divided by the total power of the vehicle,  $HF = (P_{Motor}) / (P_{Motor} + P_{ICE})$ . Simulation results are presented for HFs of 36%, 41%, 45%, 50%, 55%, 59%, and 64% only. Since higher and lower HFs do not provide promising results in parallel HEVs [11], this was also verified through simulations. The battery used was a Hawker Genesis 12 V26Ah10EP lead acid battery and the capacitor is a PC2500 Maxwell ultra-capacitor [12]. Both energy sources are pretested in ADVISOR, allowing for a very realistic model. It provides for many of the electrical properties of the energy sources to be simulated through lookup tables provided in ADVISOR. Although there are other technologies available in batteries that have characteristics more suitable for electric vehicle transportation, such as a nickel-metal hydride (Ni-MH) or a lithium-ion (Li-ion) battery [5], they are not chosen to be used because the complexities of the models (Ni-MH or Li-ion) in ADVISOR make it much more difficult to model the combined energy source. In addition, since this paper is only comparing the two energy sources and both use the same lead acid battery, it still formulates a valid conclusion for the use of the ultra-capacitors. The use of the Ni-MH or Li-ion batteries, however, can very well allow for the overall cost of the energy source to be decreased even further. Other parameters, such as the urban dynamometer driving

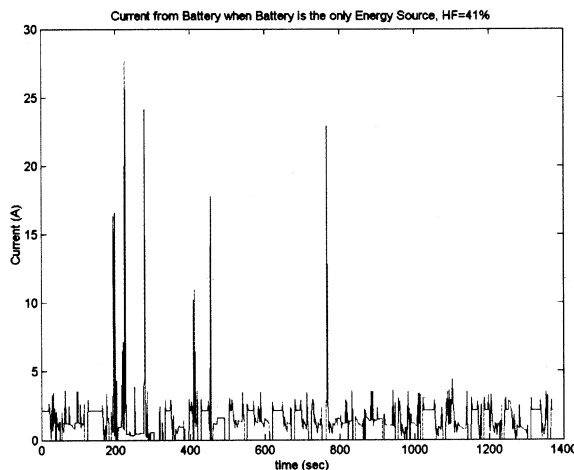

Fig. 2. Current through the battery when the battery is operating as the sole energy source.

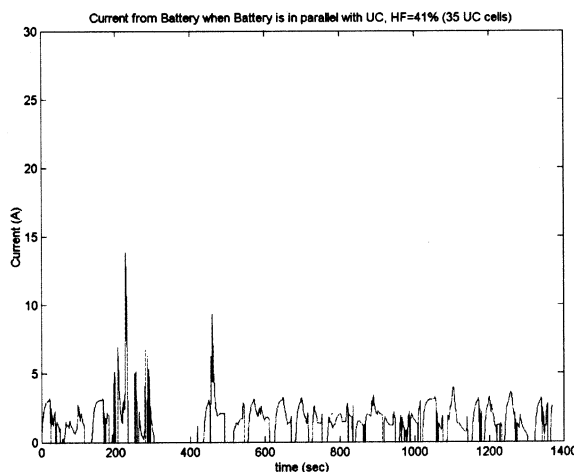

Fig. 3. Current through the battery when assisted by the ultra-capacitor.

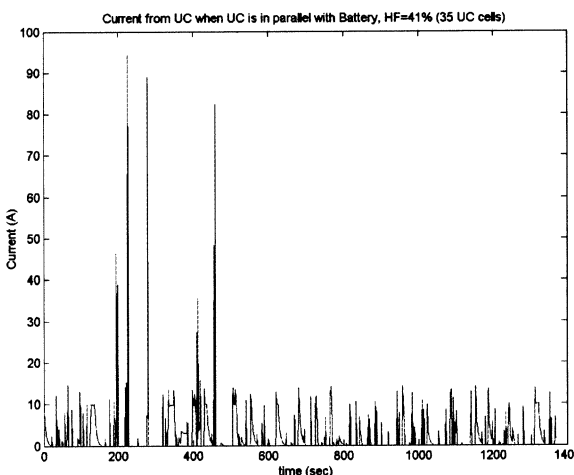

Fig. 4. Current through the ultra-capacitor when it is coupled with the battery.

TABLE V  
PEAK CURRENTS FROM ALL ENERGY SOURCES IN BOTH CONFIGURATIONS AND THEIR RELATIVE COST

HF=41%	Max Current (A)	10 year cost
Battery alone	27.6	\$7800
Battery (w/ ultra-capacitor)	13.8	\$6450
Ultra-capacitor (w/ battery)	94.6	

TABLE VI  
PERFORMANCE AS ULTRA-CAPACITOR UNITS ARE VARIED, HF = 41%

	UC units	Battery units	Fuel Economy (mpg)	Acceleration (sec)			Grade (%)	Max Speed (mph)	10 yr. Cost (\$)	% Saved
				0-60 mph	40-60 mph	0-85 mph				
Standard parallel HEV	N/A	26	37.4	8.9	4.4	18	20.5	118.4	7800	-
Battery and ultra-capacitor parallel HEV	45	18	38.3	8.4	4.1	19.2	20.3	111.2	6750	13.5%
	40	18	38.3	8.6	4.2	19.5	19.9	111.1	6600	15.4%
	35	18	38.3	8.9	4.4	19.8	19.4	111.1	6450	17.3%
	30	18	38.3	9.1	4.6	20	19	111	6300	19.2%
	25	18	38.3	9.3	4.8	20.3	18.5	111	6150	21.2%

schedule (UDDS) drive cycle, transmission, torque coupling, wheels, axle, accessory loads, and powertrain control are all held constant [9]–[11]. The configuration and number of units of the energy sources is the only parameter to be adjusted in all the hybrid simulations.

In addition, the initial SoC for the battery is produced using ADVISOR's initial SoC tolerance of 0.5%. That is, the initial SoC of the battery is calculated so that it does not deviate more than 0.5% from the average SoC during the drive cycle. This gives a more accurate simulation of the usage between the engine and electric motor. For example, if the initial SoC of the battery is higher than the normal operating conditions, the motor would run until the SoC was lowered and, therefore, increase the fuel economy beyond the realistic value [9]. The initial SoC for the ultra-capacitor was set at 0.6. This is the value that the ultra-capacitor is set to be around due to the  $K$  value. This is a viable starting point of the ultra-capacitor given that it takes about 5 s to charge the ultra-capacitor to this point.

#### IV. BENEFITS OF THE ENERGY SOURCE

ADVISOR provided the means to analyze the parallel combination of the battery and ultra-capacitor as the energy source of a hybrid electric vehicle. The initial method was to implement a simple control scheme of the converter and to verify that promising results could be achieved. The preliminary method simply divided the power in two. This straightforward technique leads to promising results, which gave credibility for a more complex and realistic implementation of the dc/dc converter. When the converter is implemented as it would realistically be used in the vehicle, the outcomes show a great potential to improve even further.

The goal of the parallel combination of the two sources is initially to reduce the current in the battery in order to decrease the cost and to increase the efficiency. Fig. 2 shows the current of the battery when it is without the ultra-capacitor. Similarly, Fig. 3 shows the current in the battery, but with the assistance of the ultra-capacitor. Both Figs. 2 and 3 have the same vehicle configurations except for the energy source. The vehicle base is 64-kW (86 hp), 41% hybridization factor, small body, parallel configuration, and simulated through the UDDS drive cycle. In the battery-only source (Fig. 2), there are 26 battery cells as the energy source. In the combined energy source (Fig. 3), there are only 18 battery cells of the same kind with an additional 35 ultra-capacitor units. The batteries in each configuration are

nominally rated at 12.33 V per cell connected in a series. Furthermore, each ultra-capacitor is rated at 2700 F; these units are also electrically connected in series.

When the ultra-capacitor is coupled with the battery, it is clear from Figs. 2 and 3 that the current is decreased by a factor of 2. In addition, there are fewer spikes of current from the battery, therefore producing a steadier current. Without the ultra-capacitor's assistance, there are eight spikes of current above 10 amps (A). With the addition of the ultra-capacitor, there is only one spike of current above 10 A, with one other close. When the current from the battery is closer to a constant value with fewer spikes, the battery has a potential for an increased efficiency and life expectancy, further reducing the cost of the energy source.

Fig. 4 illustrates how the ultra-capacitor plays a vital role in the energy source. Given that it does not store much energy, it provides very few amps unless the demand is high. The ultra-capacitor will then supply large amounts of current. In these situations, the battery will remain close to a constant current supply while the ultra-capacitor will meet the high demands of the electrical loads of the car. Without the ultra-capacitor, the battery would have to supply these currents, increasing the size and cost of the battery. Therefore, the parallel arrangement of the battery and ultra-capacitor proves to be a viable energy source to allow the use of a cheaper, smaller, and more efficient battery.

Table V summarizes the peak currents in the two different configurations in addition to the 10-year cost of the energy sources. The cost was calculated by assuming the batteries' life expectancy is 3.33 years while the life expectancy of the ultra-capacitor is 10 years. This implies that the ultra-capacitor has three times the life expectancy of the battery. The cost per each unit is \$100 per battery cell and \$30 per ultra-capacitor cell [12]. The peak current from the battery when it is the sole energy source is 27.6 A. The peak current from the battery decreases to 13.8 A when the ultra-capacitor is assisting; this accounts for a 50% reduction in peak current. This demonstrates the ability to use a smaller battery in the parallel energy-source setup. The cost decreased from \$7800 to \$6450, allowing for a 17.3% decrease in the 10-year cost. As stated earlier, the reason for the reduced cost is the ability to use fewer battery cells and to capitalize on the higher life expectancy and efficiency of the ultra-capacitor. What has not been accounted for in the cost analysis is the ability to increase the life expectancy of the battery with the use of the ultra-capacitor. The life expectancy of the battery used in the cost comparison is the same for both

TABLE VII  
COMPARISON OF THE PERFORMANCE OF THE TWO ENERGY SOURCES AT DIFFERENT HFS

	HF	UC units	Battery units	Fuel Economy (mpg)	Acceleration (sec)			Grade (%)	Max Speed (mph)	10 yr. Cost (\$)	% Saved
					0-60 mph	40-60 mph	0-85 mph				
Standard par. HEV	36%	N/A	24	37	8.9	4.4	18	20.5	118.6	7200	-
Bat&UC par. HEV	36%	30	18	37.6	8.8	4.3	19.1	19.7	113.2	6300	12.5%
Standard par. HEV	45%	N/A	29	37.5	8.8	4.3	17.7	20.8	119.1	8700	-
Bat&UC par. HEV	45%	40	18	38.7	8.9	4.5	20.5	19.2	108.9	6600	24.1%
Standard par. HEV	50%	N/A	32	36.8	8.7	4.3	17.4	21.2	119.8	9600	-
Bat&UC par. HEV	50%	50	18	38.9	8.7	4.4	20.9	19.3	106.7	6900	28.1%
Standard par. HEV	55%	N/A	36	36.8	8.5	4.1	16.9	21.8	121.3	10800	-
Bat&UC par. HEV	55%	60	18	38.6	8.4	4.2	21.5	19.4	104.5	7200	33.3%
Standard par. HEV	59%	N/A	38	36	8.5	4.1	16.9	21.8	121.1	11400	-
Bat&UC par. HEV	59%	65	18	38.4	8.4	4.2	22.5	19.2	102.4	7350	35.5%
Standard par. HEV	64%	N/A	41	32.6	8.4	4.1	16.7	22.1	121.8	12300	-
Bat&UC par. HEV	64%	70	18	37.4	8.4	4.2	23.6	18.9	100.2	7500	39.0%

cases; in reality, there is the potential for an increased life of the battery when it is with the ultra-capacitor. For example, suppose that the potential increase in the batteries life allowed the battery to last 5 years instead of 3.33. This would only require one change of the battery in the 10-year life instead of two; as a result, the cost will decrease to \$4650, a 40.4% savings. Again, this is just an example and no conclusion has been made for an actual increase in the life expectancy of the battery; there is only a potential due to the decreased current output.

The configuration used in the previous energy source was to add 35 ultra-capacitor units and decrease the battery size from 26 to 18 cells. The reason for the use of 35 ultra-capacitor units is to compare the two cases with equal performance. If more ultra-capacitor units are added to the energy source, the performance improves; likewise, if fewer units are used, a decrease in performance is observed in Table VI. Moreover, performance is directly measured through acceleration in seconds, gradeability in percent, and maximum speed in miles per hour (m/h). Gradeability is defined by the ratio of vertical feet the vehicle can climb per 100 horizontal feet. In addition, it can be noted that the fuel economy, measured in miles per gallon (m/g), is unaffected by the number of ultra-capacitor cells.

All the results discussed thus far were with a hybridization factor of 41%. The results of the other HFs are summarized in Table VII. Only the results that provide an equal performance between the two energy sources are shown. As before, the performance can be improved or degraded with the addition or reduction of ultra-capacitors, respectively. As can be seen, the savings increase as the HF increases; this is due to the fact that only 18 battery cells are required in all the different HFs. An important factor to note with the increased HF is the current versus time plots of the battery; one example is shown in Fig. 5. As the HF increases, the current characteristics become degraded such that the current from the battery does not decrease or become closer to a constant value even when the ultra-capacitors are added. Likewise, the current from the battery when with the ultra-capacitor still has quite a few current bursts. Fig. 5 shows the worst case at a HF = 64%. Again, this does not affect the savings since the cost analysis given does not take into account

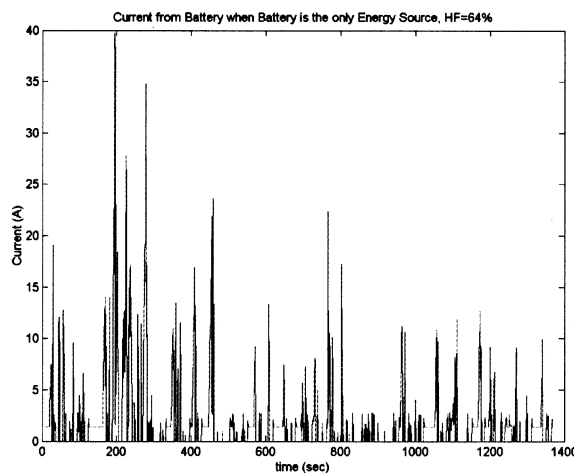

(a)

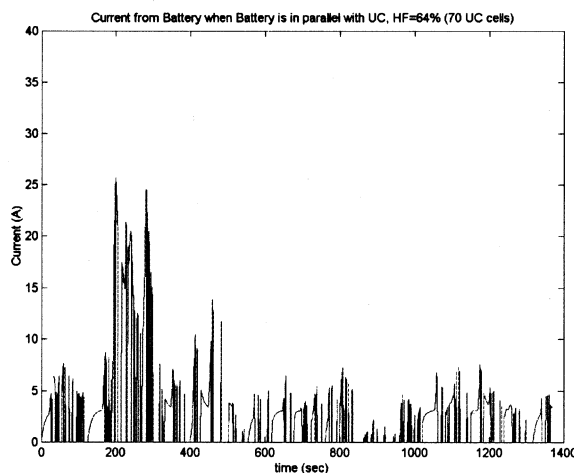

(b)

Fig. 5. Current through battery at an HF = 64%. (a) Battery is the sole energy source. (b) Battery is assisted with ultra-capacitor.

for any increase in the life of the battery. The degraded current characteristics of the battery at higher HFs will decrease the possibility for an improved life expectancy. For this reason, an HF of 41% was chosen to be discussed in detail.

TABLE VIII  
SUMMARY OF SIMULATION RESULTS

VEHICLE PARAMETERS SIMULATION RESULTS	Conventional (non-Hybrid)	Parallel Hybrid, HF=41%		% Change* of the UC/Bat Source vs:	
		Battery Source	Optimal UC & Battery Source	Conv.	Bat
Energy Storage	N/A	26 Cells	Battery 18 Cells/ UC 35 Cells		
Fuel Economy (MPG)	32	37.4	38.3	19.69%	2.41%
Acceleration 0-60 mph (sec)	11.2	8.9	8.9	20.54%	0.00%
Grade-ability @ 55MPH	16.5	20.5	19.4	17.58%	-5.37%
Max Speed (MPH)	111.9	118.4	111.1	-0.71%	-6.17%
EMMISSIONS:					
HC	0.851	0.561	0.56	34.20%	0.18%
CO	2.99	3.172	2.931	1.97%	7.60%
Nox	0.463	0.482	0.476	-2.81%	1.24%

\* A positive change declares an improvement in each category

## V. PERFORMANCE WITH THE NEW ENERGY SOURCE

Now that it has been shown that the battery current is decreased due to the addition of the ultra-capacitors, other parameters need to be checked against the standard performances for the vehicle. Although the battery conditions are improved, for a more efficient solution the fuel economy, acceleration, gradeability, maximum speed, and emissions cannot be affected for the proposed resolution to be viable. Table VIII encapsulates the simulation results, again at an HF = 41%.

As stated earlier, the drive cycle, vehicle size, engine, and motor size are held constant. The only variable adjusted is the energy-storage system. An optimal simulation was run for a conventional vehicle, a parallel hybrid vehicle with only a battery, and a parallel hybrid vehicle with a battery in parallel with an ultra-capacitor as the energy source. The conventional vehicle does not have an energy-source device, where the hybrid models obviously do. For the hybrid with only a battery source, the battery is a lead acid type with 26 cells. Furthermore, the parallel combination of the lead acid battery and ultra-capacitors has 18 battery cells and 35 ultra-capacitor cells, as before.

For each category, the battery with the ultra-capacitor energy source performed to the norm. The fuel economy of the combined energy source was mildly better than any other configuration. Acceleration remained the same since the source with 35 ultra-capacitor units was chosen. Gradeability and maximum speed with the proposed source did decrease a little as compared to the battery-only source. However, both values are considered adequate for the overall performance of the vehicle. In addition, all three of the emissions listed improved with the new battery and ultra-capacitor source. Therefore, all the parameters for the new configuration of the energy source meet or improve upon the standards set by the conventional vehicle.

## VI. CONCLUSION

In order to improve the energy source of hybrid electric vehicles, a solution to provide maximum storage and power flow was created. It has been shown that a parallel combination of a battery and an ultra-capacitor will provide both the storage and power-flow demands necessary to operate the

vehicle. After modeling the configuration in ADVISOR with Simulink, several simulations were run. The outcomes of the simulations illustrate the capabilities of improving the battery's life due to the decreased current output. Another advantage is that the user has the option to improve or degrade the performance of the vehicle through the addition or reduction of ultra-capacitors, respectively, while still saving in the cost over the sole battery energy source. Overall, the proposed energy source has a decreased cost while the performance is relatively maintained.

## ACKNOWLEDGMENT

The support of Maxwell Technologies, San Diego, CA, in donating their ultra-capacitors to the Illinois Institute of Technology, Chicago, IL, is gratefully acknowledged.

## REFERENCES

- [1] A. Emadi, M. Ehsani, and J. M. Miller, *Vehicular Electric Power Systems: Land, Sea, Air, and Space Vehicles*. New York: Marcel Dekker, 2003.
- [2] J. M. Miller, D. Goel, D. Kaminski, H. P. Schoner, and T. Jahns, "Making the case for a next generation automotive electrical system," in *Proc. Convergence Transportation Electronics Association Cong.*, Dearborn, MI, Oct. 1998.
- [3] J. G. Kassakian, H. C. Wolf, J. M. Miller, and C. J. Hurton, "Automotive electrical systems circa 2005," *IEEE Spectr.*, pp. 22–27, Aug. 1996.
- [4] J. M. Miller and P. R. Nicastrì, "The next generation automotive electrical power system architecture: issues and challenges," in *Proc. 17th Digital Avionics Systems Conference on Air, Space, and Ground Vehicle Electronic Systems*, Bellevue, WA, Oct./Nov. 1998.
- [5] C. C. Chan, "The state of the art of electric and hybrid vehicles," *Proc. IEEE*, vol. 90, pp. 247–275, Feb. 2002.
- [6] S. K. Biradar, R. A. Patill, and M. Ullegadd, "Energy storage system in electric vehicle," in *Proc. Power Quality '98*, 1998, pp. 247–255.
- [7] J. Nickerson. (2000) Ultra-Capacitors: Managing Power and Energy. FullPower Technologies, LLC, San Diego, CA. [Online]. Available: [http://www.powerpulse.net/powerpulse/archive/aa\\_061200b1.stm](http://www.powerpulse.net/powerpulse/archive/aa_061200b1.stm)
- [8] X. Yan and D. Patterson, "Improvement of drive range, acceleration and deceleration performances in an electric vehicle propulsion system," in *Proc. Power Electronics Specialists Conf.*, vol. 2, June 1999, pp. 638–643.
- [9] National Renewable Energy Laboratory. ADVISOR Documentation, Golden, CO. [Online]. Available: <http://www.ctts.nrel.gov/analysis/>
- [10] K. B. Wipke, M. R. Cuddy, and S. D. Burch, "ADVISOR 2.1: A user-friendly advanced powertrain simulation using a combined backward/forward approach," *IEEE Tran. Veh. Technol.*, vol. 48, pp. 1751–1761, Nov. 1999.

- [11] S. M. Lukic and A. Emadi, "Performance analysis of automotive power systems: effects of power electronic intensive loads and electrically-assisted propulsion systems," in *Proc. 2002 IEEE Vehicular Technology Conf.*, vol. 3, Vancouver, BC, Canada, Sept. 2002, pp. 1835–1839.
- [12] B. Maher. (2001) Ultra-Capacitors, Gateway to a New Thinking in Power Quality. Maxwell Technologies, San Diego, CA. [Online]. Available: <http://www.maxwell.com>



**Andrew C. Baisden** (S'03) received the B.S. degree in electrical engineering from the Illinois Institute of Technology, Chicago, in 2003 and the B.S. degree in mathematics from Benedictine University, Lisle, IL, in 2003. He is currently working toward the M.S. and Ph.D. degrees at the Center for Power Electronics Systems (CPES), Virginia Polytechnic Institute and State University (Virginia Tech), Blacksburg.

He was with Argonne National Laboratories as a Research Laboratory Assistant as a Summer Intern in 2000–2002. Since 2003, he has been with the CPES, Virginia Tech, as a Graduate Research Assistant. His research interests include power converters, electronics packaging, and integrated power electronic systems.



**Ali Emadi** (S'98–M'00–SM'03) received the B.S. and M.S. degrees in electrical engineering with highest distinction from Sharif University of Technology, Tehran, Iran. He also received the Ph.D. degree in electrical engineering specializing in power electronics and motor drives from Texas A&M University, College Station.

He was a Lecturer at the Electrical Engineering Department of Sharif University of Technology in 1997. He joined the Electrical and Computer Engineering Department, Illinois Institute of Technology (IIT), Chicago, in August 2000. He is the Director of Grainger Power Electronics and Motor Drives Laboratories at IIT, where he has established research and teaching laboratories as well as courses in power electronics, motor drives, and vehicular power systems. He is also the Cofounder and Codirector of IIT Consortium on Advanced Automotive Systems (ICAAS). He is the author of over 70 journal and conference papers as well as two books (*Vehicular Electric Power Systems: Land, Sea, Air, and Space Vehicles*, New York: Marcel Dekker, 2003 and *Energy Efficient Electric Motors: Selection and Applications*, New York: Marcel Dekker, 2004). He is also the Editor of the *Handbook of Automotive Power Electronics and Motor Drives*, New York: Marcel Dekker, 2004. His main research interests include modeling, analysis, design, and control of power electronic converters/systems and motor drives, integrated converters, vehicular power electronics, and electric and hybrid electric propulsion systems.

Dr. Emadi was awarded the Electric Power and Power Electronics Institute Fellowship from Texas A&M University for his graduate studies. He is the recipient of the Best Paper Presentation Award from the IEEE 27th Industrial Electronics Conference. He is also the recipient of the 2002 University Excellence in Teaching Award from IIT, as well as the Overall Excellence in Research Award from the Office of the President, IIT, for mentoring undergraduate students. He is an Associate Editor of IEEE TRANSACTIONS ON POWER ELECTRONICS and a Member of the editorial board of the *Journal of Electric Power Components and Systems*. He is a member of SAE and is also listed in the *International Who's Who of Professionals* and *Who's Who in Engineering Academia*.