

NASA Technical Memorandum 88817

NASA-TM-88817 19860022113

Aeropropulsion Opportunities for the 21st Century

William C. Strack
*Lewis Research Center
Cleveland, Ohio*

LIBRARY COPY

MAR 22 1987

LANGLEY RESEARCH CENTER
LIBRARY, NASA
HAMPTON, VIRGINIA

Prepared for the
“Scenario for 21st Century Aero Engine Design” Seminar
sponsored by the Institution of Mechanical Engineers
Bristol, England, May 16–17, 1986

NASA

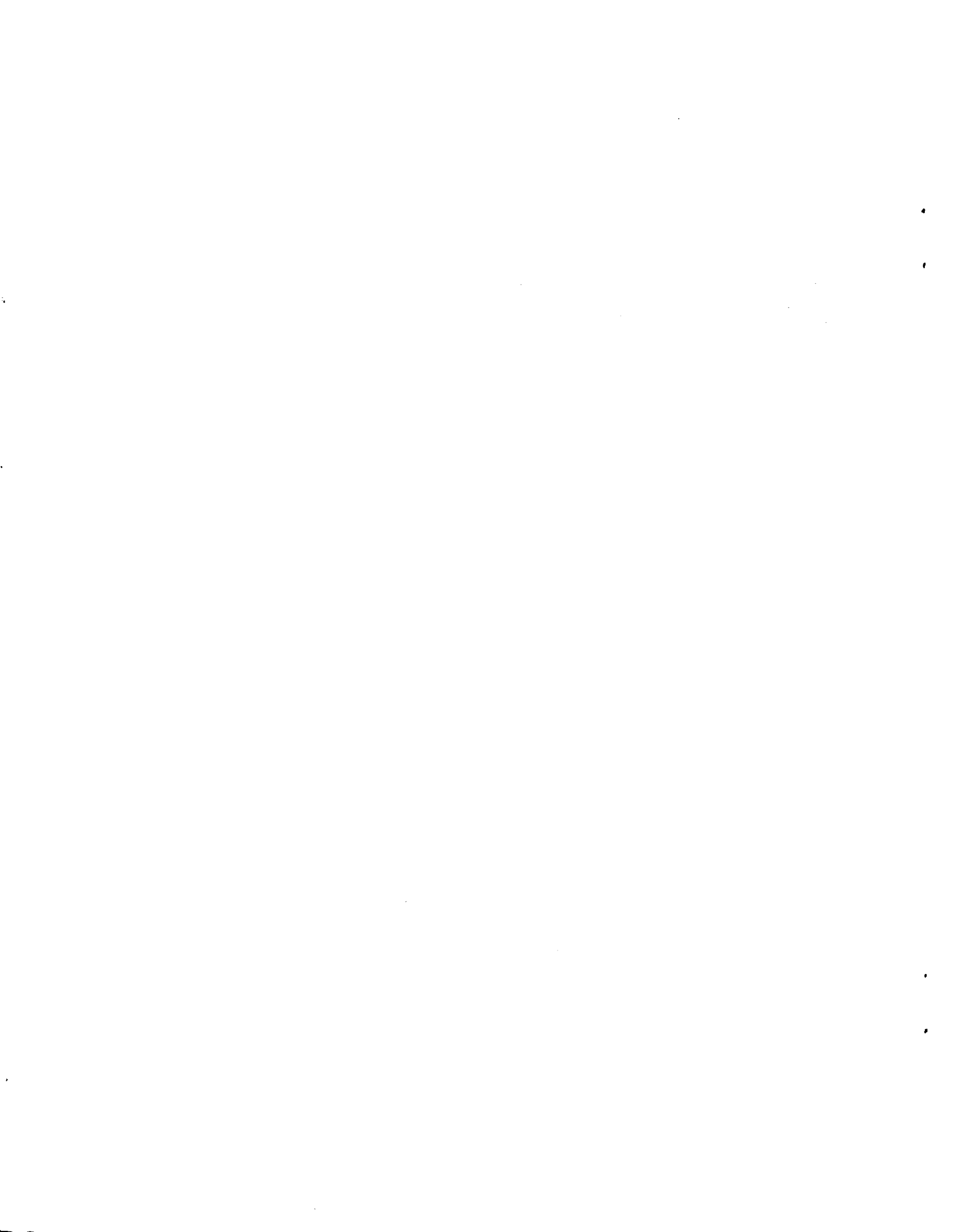

AEROPROPULSION OPPORTUNITIES FOR THE 21ST CENTURY

William C. Strack
National Aeronautics and Space Administration
Lewis Research Center
Cleveland, Ohio 44135

SUMMARY

A large number of novel aeropropulsion system concepts are presented for subsonic through hypersonic applications offering large potential improvements. Collectively, these examples illustrate the revolutionary opportunities and challenges that could enable truly revolutionary aircraft capabilities in the future. Certainly not all of these concepts will ultimately prove fruitful. Nevertheless, the sheer number of existing concepts, including many unmentioned herein, is so large and the applications so vast, that the prognosis for the future of aeropropulsion is very encouraging indeed.

INTRODUCTION

Propulsion technology is generally acknowledged to be the pacing element in the development of new aeronautical vehicles. So much improvement has been accomplished in this field that some casual observers have mistakenly concluded that the era of large gains has come to an end. While it may be true that the "easy" advances have already occurred, this paper supports the view that the future offers many important aeropropulsion opportunities--not just incremental improvements but truly revolutionary concepts enabling substantially enhanced aircraft capabilities.

These opportunities may be grouped into three categories (table I). The evolutionary development of current technology includes the fundamental discipline and component research upon which many advanced concepts rely. While extremely important, this category is not discussed here. Rather, the emphasis here is on unconventional system concepts offering potentially large step changes in improvement. An example or two is presented for each vehicle category to illustrate a diversity of future opportunities and challenges. The discussion begins with the most familiar applications and proceeds toward the more challenging, futuristic concepts.

Novel Heat Engine Concepts

Subsonic transport engines. - Remarkable progress has been achieved during the 35-yr history of jet transport engines, paced by dramatic advancements in all fundamental disciplines (fig. 1). For example, turbine inlet temperatures have risen from approximately 1000 °F to over 2500 °F as a result of much better high temperature materials capability and highly effective hot-section cooling techniques. Together with considerably improved aerodynamics and other discipline advances, these capabilities were exploited to achieve more efficient yet lightweight and durable engines. Noise and pollution concerns dominated much of the R&T effort in the 1960's and early 1970's. These efforts were quite successful in producing environmentally acceptable engine

E-3177

186-31585 #

designs. After the 1973 OPEC oil embargo, the pursuit of higher fuel efficiency resumed in earnest and today's state-of-the-art, as represented by a "maximum-efficiency E^3 turbofan engine," has nearly twice the efficiency of the first generation turbojets. The question is: Has the industry matured to the point where no more step increases in capability are forthcoming or do significant opportunities still exist?

One of the opportunities that surfaced during the 1973 oil embargo is the high speed turboprop. Its potential was largely ignored at first, but now it is the center of attention for the future. In essence, the concept is to extend the speed envelope of the high efficiency propeller from Mach 0.6 to 0.8. However, a successful Mach 0.8 propeller must be radically different than low-speed propellers (fig. 2). The blades must be swept and extremely thin to achieve good aerodynamic performance. The disk loading must be increased by a factor of 2 to 3 to avoid outlandish diameters and this leads to 8 to 10 low aspect ratio blades per disk. Consequently, conventional propeller aerodynamic approaches (two-dimensional, subsonic, isolated airfoils) must be replaced by sophisticated approaches involving three-dimensional transonic flow with cascade effects, area-ruled spinners, and specially contoured nacelles. Likewise, the structural response characteristics are considerably more complex--plate dynamics instead of beam behavior, and high-speed flutter problems to overcome.

The lure of the high-speed turboprop is its theoretical efficiency improvement of about 15 percent for single-rotation configurations. Since the swirl loss associated with single-rotation versions is about 8 percent (due to the high disk loading), considerable efforts are underway to achieve a successful counter-rotation version which should be much more efficient due to swirl-loss recovery (fig. 3). The extra efficiency improvement of the counter-rotation concept, however, is surrounded in controversy as to how best to implement the counter-rotation feature--either through a counter-rotation gearbox or through an unconventional very low-speed, gearless, counter-rotation power turbine system.

As the 21st century nears, we can make rationale, but not necessarily accurate, predictions about the future course of subsonic transport engine progress. Using a hypothetical "maximum efficiency E^3 engine" as a 1986 baseline representing the "best" engine that could be built using today's technology, studies project 20 percent mission fuel savings for future single-rotation turboprop engines using the same 1986 baseline core engine technology (fig. 4). Counter-rotation versions would be 10 percent better yet--yielding 30 percent fuel savings over a 1986 technology turbofan.

Future turbofan improvement opportunities are displayed in the left hand portion of figure 4. The first step would be a 3000 °F class, minimally-cooled, geared turbofan of 12 to 15:1 bypass ratio incorporating swept fan blading, a short/thin fan cowl, and other similar component improvements. Much composite material would be used in such an engine although the hot-section would remain metallic. Ultimately, one can envision even further turbofan advances involving extreme pressure ratios (over 100) and essentially nonmetallic turbomachinery--also yielding 30 percent fuel savings relative to the "maximum-efficiency E^3 " baseline. Finally, transferring the nonmetallic core technology of the ultimate turbofan to the counter-rotation turboprop leads us to a nonmetallic counter-rotation turboprop with a theoretical fuel savings potential of approximately 45 percent. This represents an ultimate goal for

future propulsion research and technology, and dispells the notion that only small incremental gains are possible in the future.

Small engines. - While the quest for large turbine engine improvement has been very satisfying, the continued lag in small engine performance is disturbing. Small 500 hp turbine engines are about 1/3 less efficient than their 20 000 hp counterparts of comparable technology (fig. 5). This adverse turbomachinery performance scale effect is due to many causes, including increased relative leakages, low Reynolds number penalties, poorer blade manufacturing fidelity, inability to utilize intricate cooling schemes, etc. These constraints/effects also limit the cycle pressure ratio achievable which compounds the problem. Consequently, much of the sophisticated technology developed for large engines is not transferable to the small engine category. NASA has been interested in pursuing small engine technology, guided partly by its own assessment of potential solutions to this dilemma, as reflected in the next several figures.

Figure 6 depicts the large performance gains that are feasible for 800 shp turboshaft engines with optimistic component performance assumptions. A hypothetical current state-of-the-art (SOA) engine is defined as a baseline having a pressure ratio of 14:1 and a 2200 °F turbine inlet temperature. An aggressive small engine research program could lead to improved turbomachinery component performance, elimination of turbine cooling through the use of ceramic combustors and turbines, and a better cycle using pressure ratios in the low to mid 20's and 2600 °F turbine inlet temperatures. Such an advanced simple cycle engine offers 17 percent lower brake specific fuel consumption (BSFC) and 60 percent more specific power. Adding an advanced regenerator or recuperator could lead to a spectacular 37 percent BSFC improvement, while compromising specific power somewhat. While regenerative cycles appear attractive on a cycle performance basis, it is necessary to consider their extra weight, size, and cost penalties through appropriate mission analyses before rendering a judgment.

For a typical commuter application, advanced small engine technology (ASET) could deliver from 23 to 43 percent fuel savings compared to today's state-of-the-art technology (fig. 7). For the simple cycle, fixed mission case, the lower fuel and engine weights also permit an 8 percent airframe weight savings--yielding a direct operating cost (DOC) savings of 12 percent assuming \$1.75/gal fuel. The corresponding payoff for regenerative engines is unclear due to the uncertainties associated with heat exchanger weight, size, and cost. Regenerative engine DOC payoff ranges from a low of 12 percent (assuming the regenerative engine is 50 percent heavier, adds 5 percent to the airplane zero-lift drag, and costs 20 percent more than a simple cycle engine) to as much as 20 percent assuming no regenerative penalties at all. Thus regenerative cycles offer alluring potential, yet equally difficult technical challenges.

Small engine applications are rather diverse in terms of size, flight speed, utilization rates, engine configuration, and so forth. Recent studies project revolutionary gains are feasible for all applications--20 to 50 percent fuel savings and 12 to 20 percent less DOC (fig. 8). Achieving such gains requires considerable discipline and component/systems R&T including ceramic composite materials, centrifugal compressors, reverse flow combustors, radial inflow turbines, and heat exchangers.

High speed rotorcraft. - Although substantial progress has been achieved with conventional helicopters, visionaries have long dreamed of a commuter aircraft capable of taking off and landing as a helicopter yet cruising smoothly and rapidly as a fixed-wing airplane. The folded-tilt-rotor concept provides one answer to this design problem (fig. 9). As originally conceived, however, this concept suffered seriously from the "double propulsion" penalty--one set of engines used for vertical operations and a second set used for high speed cruising. What is needed to make these high speed rotorcraft concepts tractable is a new kind of powerplant that can act as a turboshaft engine to provide rotor-lift during takeoff and landing but convert to a turbofan or turboprop during wing-borne flight to supply forward thrust.

A successful convertible engine would enable the realization of extending the helicopter's limited flight envelope to much greater speeds and altitudes. A series of analyses revealed that dramatic economic improvements are possible using convertible engines for a spectrum of vehicle types and missions. For example, 450 knot X-wing and folded-tilt-rotor vehicles would be 15 to 22 percent more economical than similar craft powered by separate function engines (fig. 10).

One convertible engine scheme is illustrated in figure 11. A fixed pitch fan is used in conjunction with partial-span variable inlet and exit guide vanes. These variable vanes adjust the flow angles and flow area sensed by the fan stream, and thereby control the power absorption capability of the fan. A flow splitter on the fan is used to essentially uncouple the core flow from the outer fan flow. This maintains core airflow in the turboshaft mode when the outer fan airflow is blocked. Speed reduction gearing and a clutch are necessary in the power takeoff for the rotor. With these modifications, an otherwise conventional engine is able to continuously modulate the power delivered to the rotor and the fan. This concept is well-suited to the X-wing vehicle where some shaft power is always needed to drive the auxiliary compressors. Some experimental research on this concept has already been conducted that addresses the amount of residual thrust at takeoff, temperature in the fan cavity when the outer stream is nearly blocked, noise, and blade/vane stall flutter limits.

Another convertible engine concept features a torque converter to modulate the power (fig. 12). During vertical operations, the torque converter is drained of oil hence all the core power is delivered to the rotor shaft gear-train. During the conversion to the turbofan mode for high-speed cruise, oil is pumped into the torque converter cavity which fluid-couples the core output shaft to the fan shaft. After the torque converter is completely filled (about 15 sec), the fan speed is matched to the core speed by adjusting the torque converter oil pressure. When the fan and core speeds are matched, a lockup device is actuated which converts the fluid coupling to a direct mechanical coupling, and then the oil is drained to avoid churning losses. This concept would be well-suited to future folded-tilt-rotor vehicle where all of the engine power is directed either to the rotor or the fan, but not split between them (except during conversions). Key technology issues include impeller cavitation, fan windmilling, converter design data, and lack of core supercharging at takeoff. Only theoretical analyses have been undertaken so far--no experimental database exists for aircraft applications or in the size class needed.

Supersonic fighter. - While engine weight is not nearly as important as engine efficiency for most civil applications, modern fighter-type airplanes

need such high thrust loadings (approximately 1.2) that the powerplant represents about 20 percent of the takeoff gross weight, TOGW (fig. 13). Historical progress in engine thrust-to-weight ratio (T/W) has continued at a linear rate of doubling every 20 yr due principally to improvements in high temperature materials and cooling technology. Today we stand at the threshold of reaching forward enough further to attain supermaneuverability and practical supersonic STOVL capability. Future gains in engine T/W will be paced by more exotic material technologies--eventually reaching stoichiometric combustion with little, if any, hot-section cooling flow. Unconventional cycles are also strong contenders as we enter the 21st century. Of course, high T/W by itself is not sufficient to reach these new capabilities, we also need to establish sophisticated thrust-vectoring technologies and new engine concepts permitting efficient operation over the entire flight speed spectrum.

Many thrust vectoring concepts for supersonic V/STOL have been identified, but none have yet emerged as clearly superior to the others. Mission definitions, including operational constraint specifications, powerfully affect the outcome of comparative evaluations. Since universal agreement on a future mission definition remains elusive, it may be some time before "the best" concept is finally selected. Meanwhile, current activities are directed toward the identification of technology drivers common to all or most of the leading contenders. The 21st century will certainly witness supersonic V/STOL aircraft--but it is just too early to predict which propulsion system(s) will prevail.

The deflected thrust system (fig. 14) is the only U.S. operational V/STOL system to date (subsonic Harrier). It is the simplest of all the schemes and its well-developed subsonic technology could be extended to supersonic speeds relatively easily. But it would probably be limited to only short periods of supersonic flight due to its inherently large cross-sectional area located near the airplanes' widest section, and it (as well as most other concepts) has a very hot "footprint." The ejector system avoids the hot "footprint" difficulty but is fraught with packaging complexity and challenging unproven aerodynamic performance.

Some of the STOVL propulsion concepts involve many modes of operation, and thereby depart radically with previous experience. A STOVL ejector system, for example, might require at least the 5 modes illustrated in figure 15. Horizontal runway acceleration is effected with the ejector deployed but not activated. The core flow is afterburned and the fan flow is diverted through a separate duct burner/nozzle arrangement for maximum acceleration. Just before liftoff, the fan duct burner is shut off and the fan nozzle is closed in order to activate the forward-mounted ejector. Simultaneously, the core nozzle is deflected downward at the proper angle to provide more lift and balanced longitudinal thrust moments. This is a rather exciting takeoff since, at the most critical time, the propulsion system is reconfigured and the ejector must start pumping nearly instantaneously to effect a successful liftoff. During subsonic cruise, the ejector is stowed and the engine behaves as a conventional separate-flow dry turbofan. During combat the afterburner and duct burner are relit. The landing mode invokes the ejector, closes the duct nozzle completely, and swivels the core nozzle vertically--without using the afterburner if the airplane has lost enough weight during the flight. There are obviously many variations to this particular scenario.

Two other V/STOL propulsion concepts of interest are the remote augmented lift system (RALS) and the tandem fan system, neither of which have been actually demonstrated (fig. 16). The RALS may be viewed as a derivative of the vectored thrust system in which the fan stream lift-producing nozzle location is unconstrained. This permits much greater freedom in finding an acceptable low-drag engine location as well as a better thrust balanced arrangement.

The tandem fan system uses a split fan arrangement, flow diverter, and auxiliary inlet to increase bypass ratio during the lift-producing mode and increase the separation distance between the fan and core nozzles.

Each V/STOL propulsion concept involves alternative configurations, and each raises specific technical challenges. Only through a comprehensive systems analysis, followed by a technology program that addresses these concerns, will we acquire the knowledge necessary to determine the most attractive candidates. Nevertheless, one or more of these novel concepts will eventually be developed into a very effective supersonic V/STOL powerplant.

Supersonic cruise. - Although the Olympus-powered Concorde captured only a limited market, it nevertheless ushered in the age of the supersonic transport (SST). As the 21st century approaches, the economic penalty of sustained supersonic cruise is likely to decrease substantially barring a severe resurgence in fuel prices. This optimism is predicated on the belief that more breakthrough opportunities exist for this flight domain than for subsonic flight, plus the increased demand for short trip times over long distances. A thorough reexamination of SST technical, economic, and environmental issues is now required to guide future research programs for high speed transports. Novel, possibly radical, concepts should be seriously considered in light of potential payoffs and technical risk. Propulsion researchers should set their goals on achieving much better engine efficiency during all mission segments, lower engine weight, and lower noise (fig. 17).

The turbine bypass engine (TBE) represents an alternative approach to achieving variable cycle capabilities required of engines designed to operate efficiently at subsonic and supersonic conditions. The traditional approach to the subsonic-supersonic dilemma adds considerable complexity to a two-spool turbofan engine in the form of many variable geometry features to alter the flowpaths and cycle. It becomes quite complicated to analyze and expensive to produce and maintain. The TBE offers a much simpler, single-spool turbojet solution (fig. 18). At part power conditions it operates just as an ordinary turbojet. Above approximately 85 percent throttle setting, a fraction of the compressor discharge air is bypassed around the combustor-turbine section and reintroduced into the turbine exit flow. This scheme behaves similar to a variable area turbine: it maintains high airflow and component efficiency at part power, and incurs only low spillage and boattail drag. It is especially attractive at very high turbine inlet temperatures since it then avoids the need for an afterburner. The payoff is an engine 30 percent less expensive than a variable geometry duct burning turbofan with superior efficiency at maximum power.

One potential SST breakthrough is the supersonic fan concept (fig. 19). Instead of using a long and heavy inlet system to efficiently decelerate the intake airflow to the subsonic speeds required by conventional fans, the supersonic fan efficiently processes air at supersonic throughflow velocities. The advantages include much lower inlet system weight, lighter fan (less stages

required for a given pressure ratio), less spillage drag, better inlet pressure recovery, and better matching of bypass ratio variations to flight speed. Preliminary estimates of the propulsion system weight savings are 15 to 20 percent in addition to 10 to 20 percent better cruise efficiency. Of course, there are many unknowns and challenges. What are such a fan's low speed operating characteristics? For high supersonic flight speeds (e.g., Mach 5) it may be necessary to add heat to the fan discharge stream at supersonic velocities to produce sufficient thrust. Can this heat be added without incurring excessive pressure losses? Very little effort has been expended on this concept to date. Thus, it is possible that future advances in aerodynamic technology will resolve these unknowns and challenges. Meanwhile, to alleviate these difficulties, a sensible first application would be one that avoids wide off-design operation--such as an air launched cruise missile.

Hypersonic cruise/trans-atmospheric. - Sometime in the 21st century it is quite likely that the world will witness hypersonic cruise vehicles. These will almost certainly rely on the hydrogen-powered supersonic combustion ramjet (scramjet) technology now being established at NASA (fig. 20). This high-speed air-breathing technology is still in its infancy with many uncertainties. But the considerable progress made over the last decade has demonstrated the feasibility of this concept.

Achieving sustained hypersonic speeds requires an extraordinary degree of systems engineering: the vehicle itself becomes a major part of the inlet and exhaust systems, thermal management strives to match the vehicle cooling requirements to the propulsion system flow rates--both of which are functions of the trajectory--and so forth. Successful vehicles will be the result of resolving extremely challenging technical difficulties and design tradeoffs.

An obvious hypersonic cruise vehicle challenge is selecting a reasonable propulsion system since no single powerplant type operates effectively over a speed range of Mach 0 to 25. Although rockets are extremely lightweight and operate well at any speed, their low efficiency eliminates their use for cruising type vehicles. Conversely, the air breathers are much more efficient but heavier and each type is restricted to a relatively narrow speed spectrum (fig. 21). Considerable uncertainty exists regarding the selection of the most attractive propulsion strategy, reminiscent of early aviation history when the merits of biplanes, radial aircooled reciprocating engines, jet engines, etc. were hotly debated. It is quite possible that a combined or hybrid propulsion system that can operate in several modes, depending on flight speed, may emerge as the preferable system.

It is generally conceded that only the scramjet is viable for cruising at flight speeds in excess of Mach 6. It is not yet clear what maximum speed the scramjet can attain. Moreover, accelerating from takeoff to scramjet speeds will require another, as yet undetermined, propulsion system. NASA is investigating a broad range of candidate propulsion concepts in an attempt to determine the domain of superiority of each concept. Many new concepts have been identified since the last wave of such activity some 15 yr ago, so this investigation involves more than just updating previous results. The sketches presented in figure 22 illustrate some of the concepts under consideration for both hypersonic cruisers and trans-atmospheric applications.

Revolutionary Concepts Requiring Radical Infrastructure Change

Hydrogen topping cycle engine. - Except for extremely demanding applications such as hypersonic vehicles, the use of fuels as unconventional as hydrogen is seldom seriously considered due to the enormous infrastructure change required. Nevertheless, it is appropriate to study the use of such fuels for a time frame extending well into the 21st century due to unpredictable future fuel scenarios. From that viewpoint, one might well ask: If we eventually have a hydrogen fuel economy, how best could we exploit its properties? One answer to that question is suggested in figure 23 in the form of a topping cycle that exploits the cryogenic properties of LH₂ to increase the overall efficiency of a subsonic transport engine 12 to 20 percent. About 15 percent of the airflow is interstage bled from the compressor and inter-cooled before further compression in the topping loop. The heated hydrogen is then mixed and burned in the topping loop, very fuel rich, before expanding through the auxiliary power turbine on its way to the main engine burner. The auxiliary turbine is geared to the main engine shaft and provides about 15 percent of the total power. Although the topping loop adds weight, the main engine can be downsized enough to yield approximately the same overall weight as a conventional engine delivering an equal amount of thrust.

Nuclear powered cruise airplane. - From strictly a technical perspective a nuclear powerplant offers considerable potential for large-sized airplanes. It offers almost unlimited range, endurance, and auxiliary power. One implementation of the concept utilizes high pressure helium to transfer heat from the reactor to the compressor discharge air via a heat exchanger (fig. 24). A radiation shield surrounds the entire reactor assembly rather than partially as in some early concepts. Conventional chemical fuel operations would be used for takeoffs and landings, and any in-flight emergencies.

Past studies have indicated such a concept to be quite feasible and technically attractive for airplane takeoff weights over approximately 1 million pounds, including onboard crash protection and afterheat removal systems. A C-5A sized nuclear airplane is feasible too, although its payload capacity would be only 1/2 that of a conventional airplane (fig. 25). Years ago, some interest in nuclear airplanes existed and safe designs conceptualized. Little experimental safety validation was conducted, however, and in today's political situation, the nuclear airplane concept is currently untenable regardless of its technical merit.

Solar powered aircraft. - Solar powered flight involving direct conversion of sunlight to electrical power through the use of solar cells has already been demonstrated in small, slow flying unmanned aircraft (fig. 26). Extending this concept to broader applications seems quite unlikely due to the low conversion efficiency of the cells and the inherent power per unit area limitation of sunlight. A significant additional problem is the dependency of received power to the aircraft's orientation to the sun's rays which necessitates an energy storage system to maintain a steady thrust force. Still, such systems may well suffice for some special purpose applications requiring small payloads and long endurance. These systems also offer small thermal signatures and quiet, smooth operation.

Fuel-cell propulsion. - Early fuel-cell concepts reacted lithium with onboard hydrogen peroxide to form lithium hydroxide and electrical power. Being a nonairbreather the power output of such a system is largely independent of altitude, an advantage; but does incur a weight penalty since all of the consumables (Li and H₂O₂) must be carried onboard. The version shown in figure 27 uses oxygen from the air to react with the lithium and CO₂ to control the reaction rate. This substantially reduces the amount of consumables required, but has the unique property of adding propulsion system weight (Li₂CO₃) as the flight progresses--unless it is dumped overboard. These systems have much higher power densities than the solar-cell concept, energy densities about the same as thermal systems, and are independent of the sun-vehicle orientation. Although technical problems exist, the fuel-cell concept is certainly feasible and it can provide attractive performance. The more important issues are economic concerns: the availability and cost of lithium, matching consumables and missions, and the establishment of a new industry to reclaim and recycle lithium.

Microwave powered aircraft. - Another type of electric power system is microwave, where power is transmitted by ground-based antennas located nearby an electric power line or station (fig. 28). Microwave powered aircraft (as well as solar-cell and fuel-cell propulsion systems) enjoy an independence from hydrocarbon fuel supplies. Little onboard fuel is needed since energy is beamed to it once it is in position over a transmitting antenna. Theoretically, it has unlimited range/endurance, but is geographically limited to maintain close proximity to the transmitters. Limited small-scale experiments have demonstrated feasibility but essentially the technology remains undeveloped. The cost and practicality of the ground transmitting stations are obvious challenges.

Beam powered aircraft. - The space-based laser concepts are less constricting than ground power sources and possess superior power densities, but present even more challenging technical and economic problems. One concept is to place a large power satellite in a sun-synchronous orbit which beams a laser to the aircraft (fig. 29). The power satellite would use a solar-Brayton cycle to convert sunlight to thermal energy, and couple the Brayton engine to an electrical generator to power the laser system. Since the airplane and the power satellite are not usually aligned properly, a relay satellite placed in an elliptical orbit is used to satisfy the geometry requirements. In one possible implementation, the aircraft would intercept the beam with a receiver/concentrator which feeds the power to the burner section of an otherwise conventional turbofan/turboprop engine. Both technical and economic problems are staggering considering that a single 200-passenger transport requires about 40 to 50 MW of power in cruise flight, and the antenna pointing accuracies must be extraordinarily precise. The lure of achieving such high power densities using nonfossil fuels must be tempered, at least for now, by realizing that such systems are likely to be extremely expensive.

The preceding example of laser-propulsion combined an exotic power transfer mechanism (laser) with a conventional air-breathing heat engine (turbofan) to propel a conventional aircraft along a conventional flight path. The more elegant and visionary concept depicted in figure 30 dispenses with tradition altogether (ref. 1). It is a multimode space-based beam-powered transport void of turbomachinery and heat exchangers but still reliant on air as a working fluid. The cone shaped vehicle takes off vertically (vehicle in left background) with an annular array of pulsed laser beams entering the upper side

optical portholes, and focused just beneath the vehicle to create a rapid sequence of laser-supported detonation waves that impart upward momentum to the lower surface of the vehicle. After a very rapid rise to about Mach 1 and 3 km altitude, the VTOL mode ceases and the rotary air-breathing pulsejet mode begins as depicted in the right foreground. This mode is used to laterally accelerate to Mach 3 and 30 km. Except for the central payload compartment, the entire vehicle rotates and air is admitted sequentially to a series of pulsejet chambers when they face forward along the flight path. As each chamber rotates to its rearward location, a single intense laser beam is focused within the chamber to initiate a laser supported detonation wave which heats and pressurizes the air before it is expelled through a nozzle to produce thrust.

As the laser-powered vehicle enters the rarified upper atmosphere, it switches to a pulsed electromagnetic equivalent of an air-turborocket (fig. 31). The ends of telescoping electrodes define a large streamtube boundary. Pulsed incoming laser-power is focused at the slipstream perimeter to initiate a detonation wave that propagates inward in the form of a high conductivity plasma disk. When the wave arrives at edge of the vehicle, it enters MHD generator ducts, the laser beam is turned off, and gaseous hydrogen is injected into the MHD ducts. The detonation wave causes the hydrogen gas to form an ionized plasma that explosively drives the MHD generator into generating a powerful burst of electrical energy. The short intense electrical burst is short-circuited through the high-conductivity plasma "actuator disk" and produces a shock wave extending from the vehicle to the electrode tips. The shock wave expands and accelerates rapidly downward entraining nonionized ambient air in the process, thereby producing thrust.

In addition to novel vehicle and propulsion concepts, this approach involves boost-glide type flight paths to extreme altitudes and gigawatt power levels. Intriguing schemes such as this are ripe with technical and economic challenges, and the benefits are not well-understood. Nevertheless, they deserve consideration in analyzes of very long term opportunities.

CONCLUSION

As the 21st century approaches, it is clear that novel propulsion opportunities exist for all types of powered aircraft (fig. 32). Advanced propulsion concepts and technology applied to the subsonic flight regime offer 50 percent-level fuel savings for every category of application--large and small. For supersonic applications we foresee a doubling of propulsion capability through a combination of weight reduction and high performance technologies. This will lay the foundation for efficient sustained supersonic cruise, supersonic V/STOL, and highly maneuverable aircraft. Entirely new aeronautical capabilities await us in the hypersonic arena. The pursuit of the British Hotol and the U.S. Aerospace Plane propulsion technology programs are the third part of what may be called the "21st century aeropropulsion renaissance." Achieving these propulsion goals will indeed enable truly revolutionary aircraft capabilities for the future.

REFERENCE

1. Myrabo, L.N., A Concept for Light-Powered Flight. AIAA Paper 82-1214, June 1982.

TABLE I. - AEROPROPULSION OPPORTUNITY CATEGORIES

- | |
|--|
| <ol style="list-style-type: none">1. Evolutionary development of current technology2. Novel heat engine concepts<ul style="list-style-type: none">• Subsonic Transport• Commuter/general aviation/helicopter/cruise missile• High speed rotorcraft• Supersonic fighter• Supersonic Cruise• Hypersonic cruise/trans-atmospheric3. Revolutionary concepts requiring radical infrastructure change<ul style="list-style-type: none">• Alternate fuels• Nuclear power• Electric power (solar and fuel cells)• Microwave beam power• Laser beam propulsion |
|--|

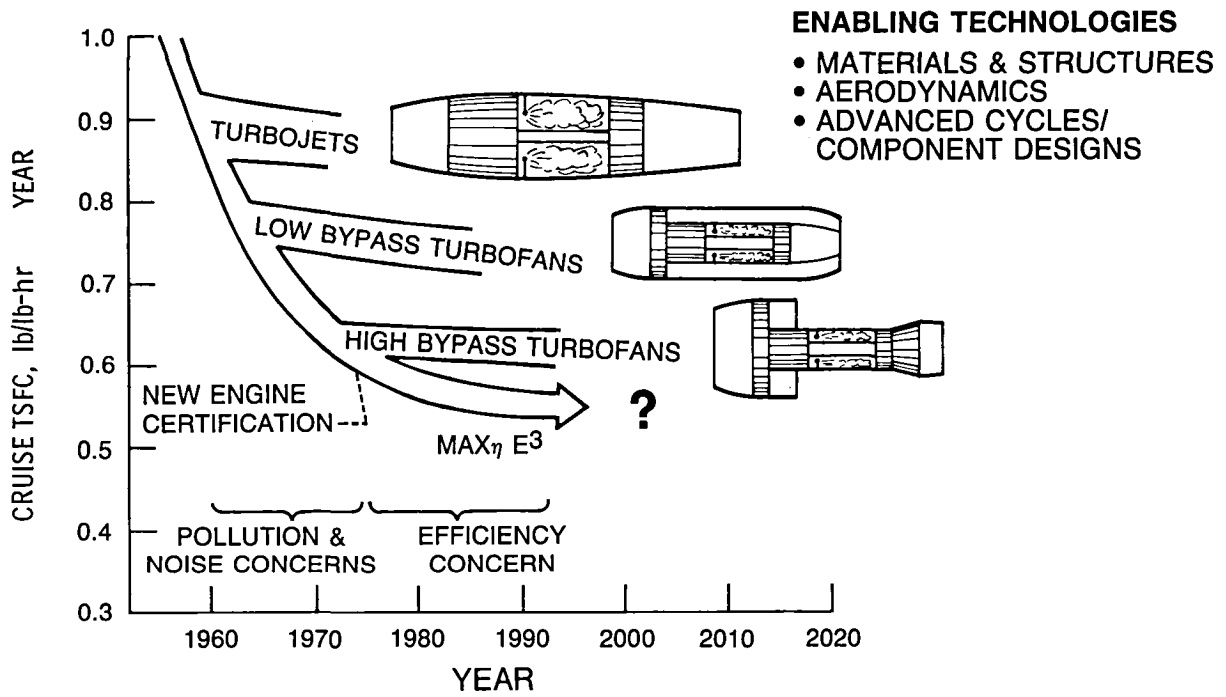

FIGURE 1.- THE NEXT MAJOR STEP IN FUEL EFFICIENCY.

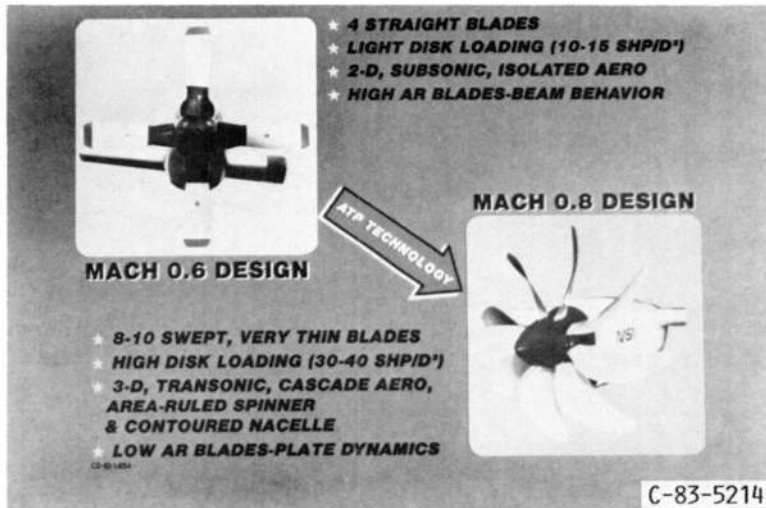

FIGURE 2. - ROUTE TO IMPROVED FUEL EFFICIENCY.

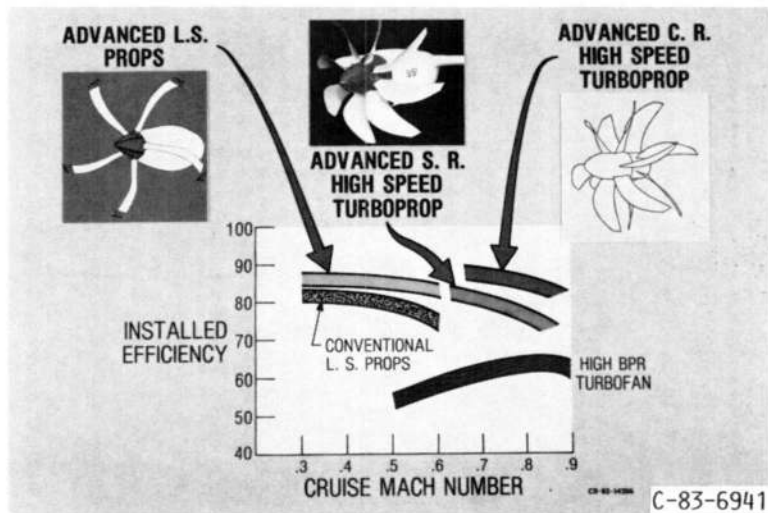

FIGURE 3. - INSTALLED CRUISE EFFICIENCY TREND.

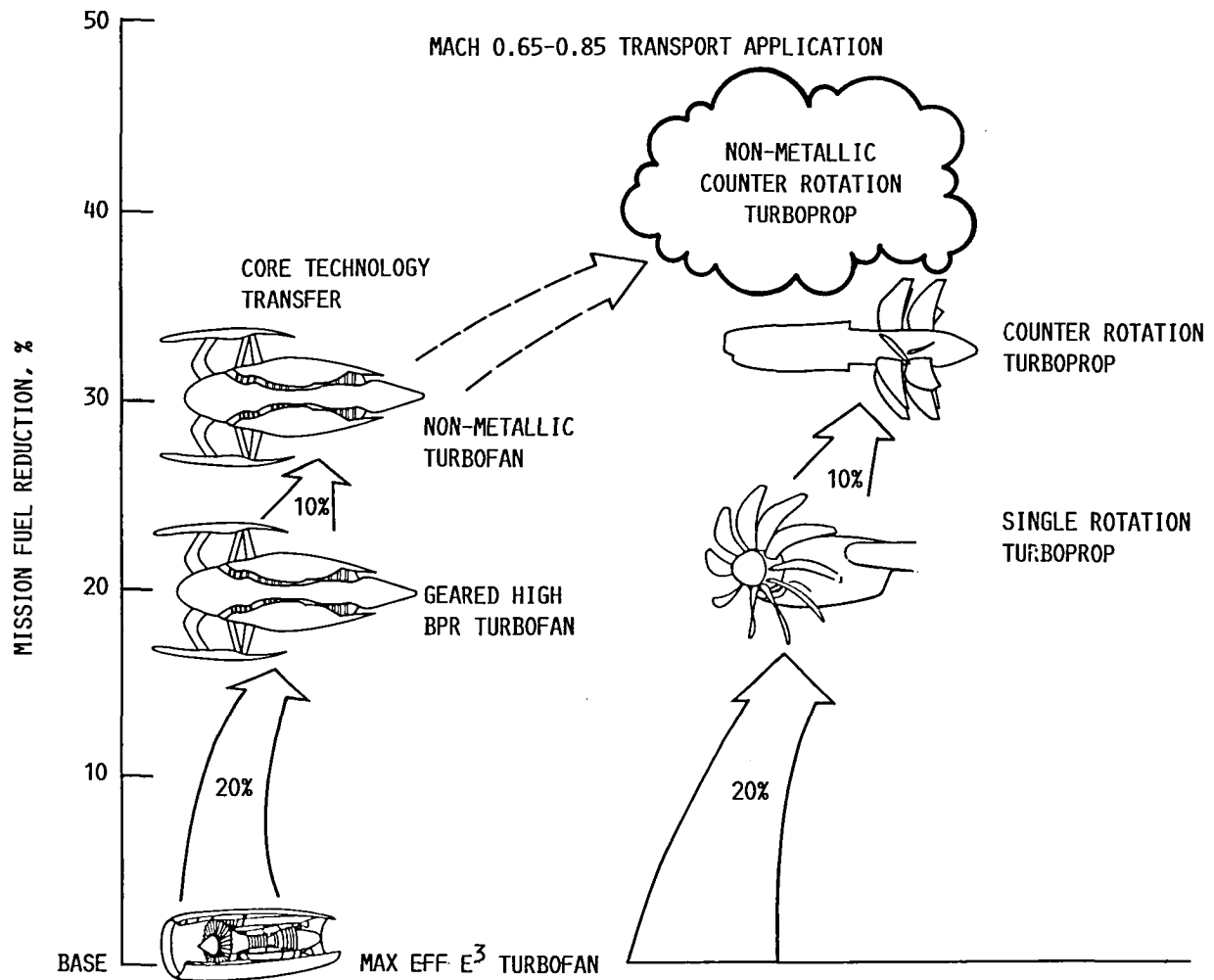

FIGURE 4.- YEAR 2000⁺ PROPULSION OPPORTUNITIES.

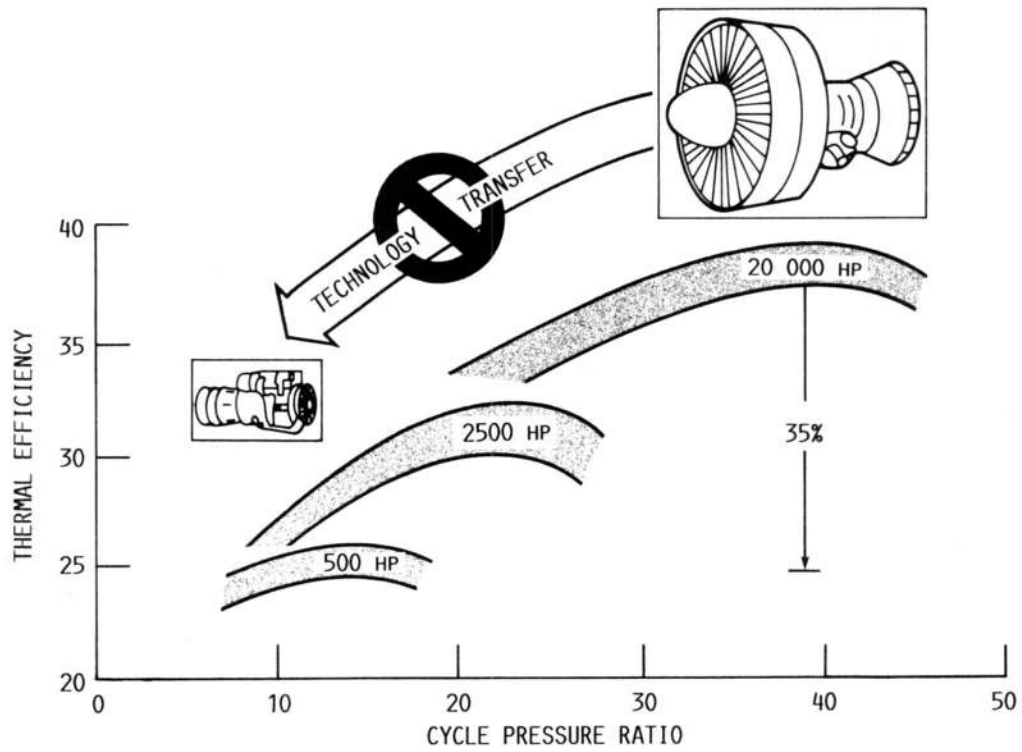

FIGURE 5.- SMALL ENGINES ARE NOT AS EFFICIENT.

800 HP SLS

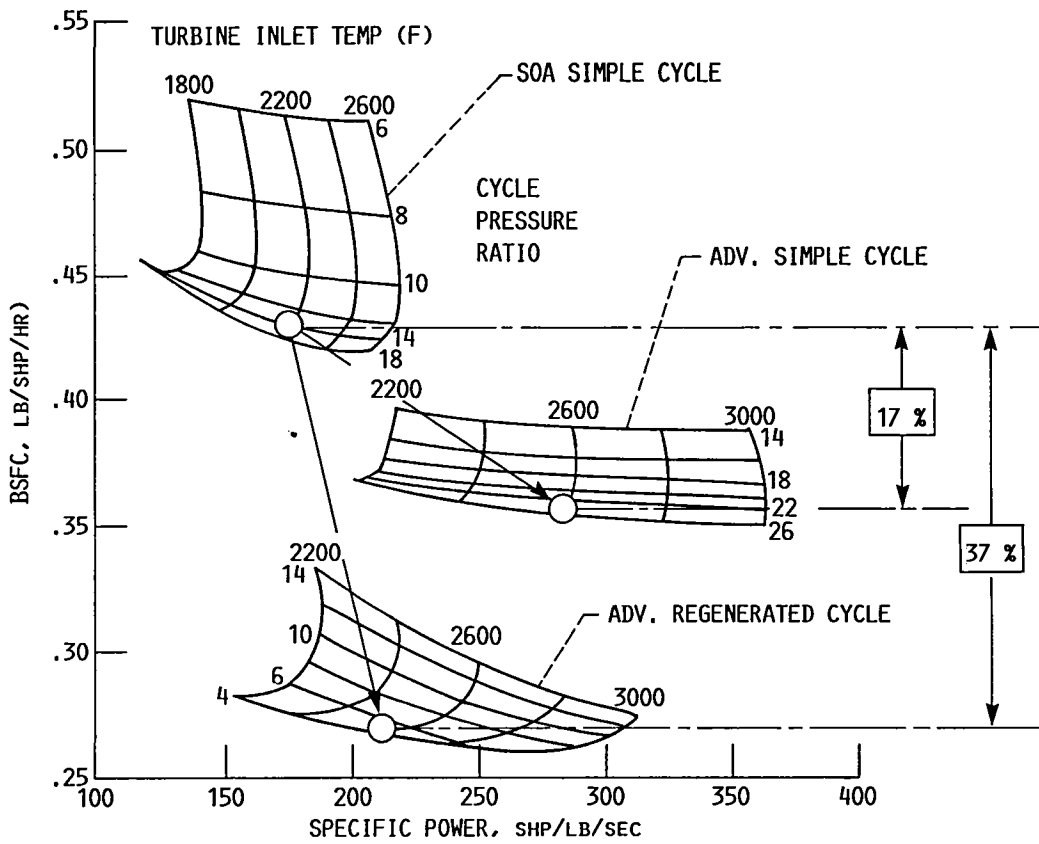

FIGURE 6. - IMPACT OF ADVANCED TECHNOLOGY ON CYCLE PERFORMANCE.

19 PASSENGER, MACH 0.415, 10,000 FT. ALT., 600 N.M. RANGE, 1200 SHP/ENG.

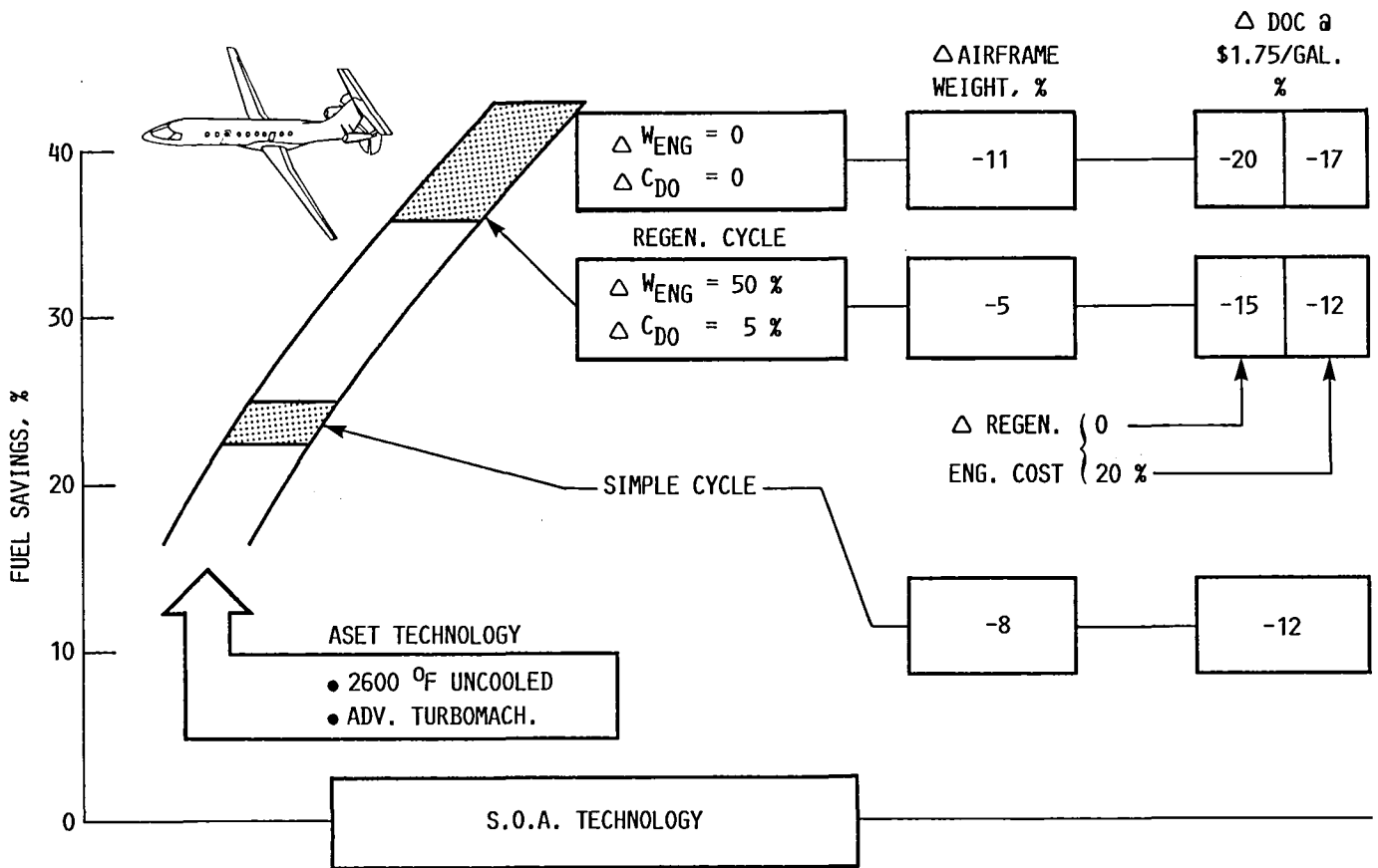

FIGURE 7.- SMALL ENGINE TECHNOLOGY BENEFITS - COMMUTER APPLICATION.

TECHNICAL EMPHASIS

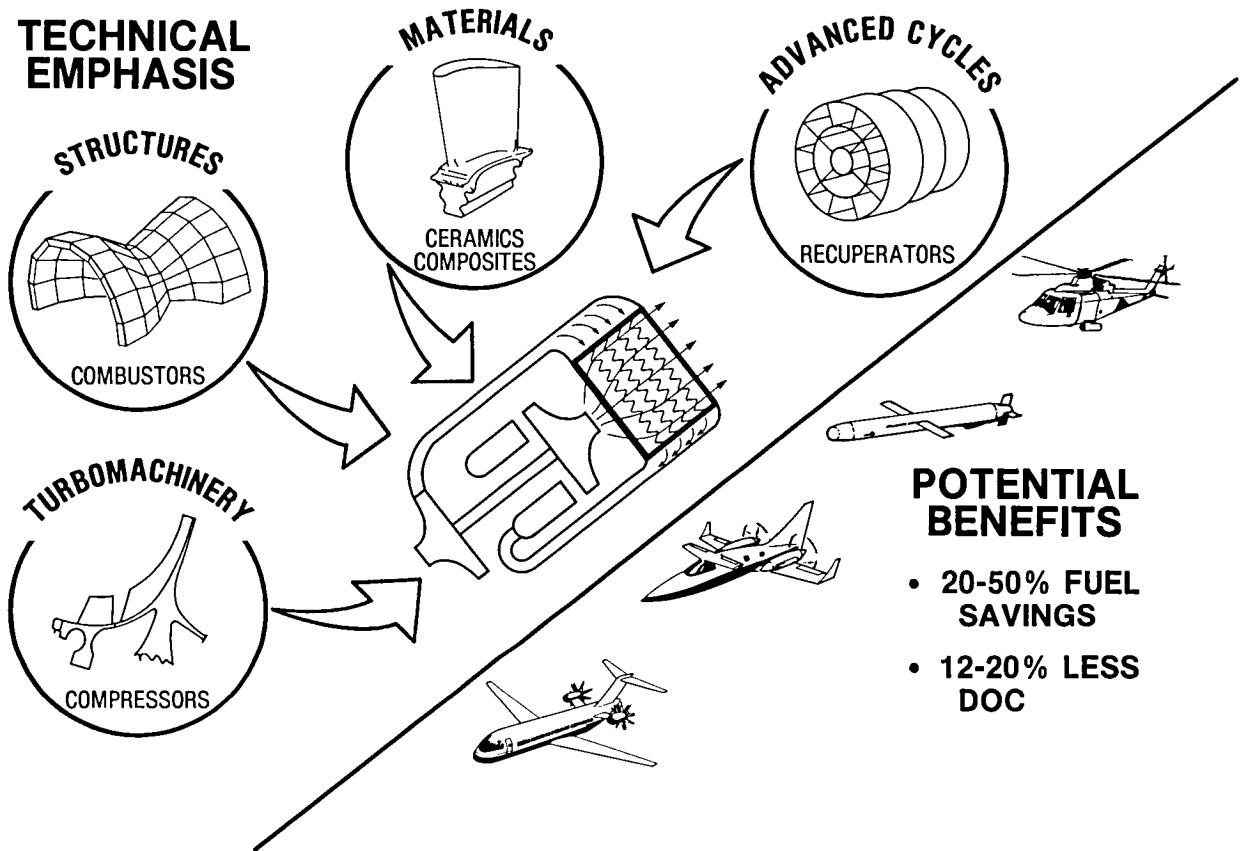

FIGURE 8.- ADVANCED SMALL ENGINE TECHNOLOGY.



FIGURE 9. - FOLDED TILT-ROTOR HIGH-SPEED ROTORCRAFT.

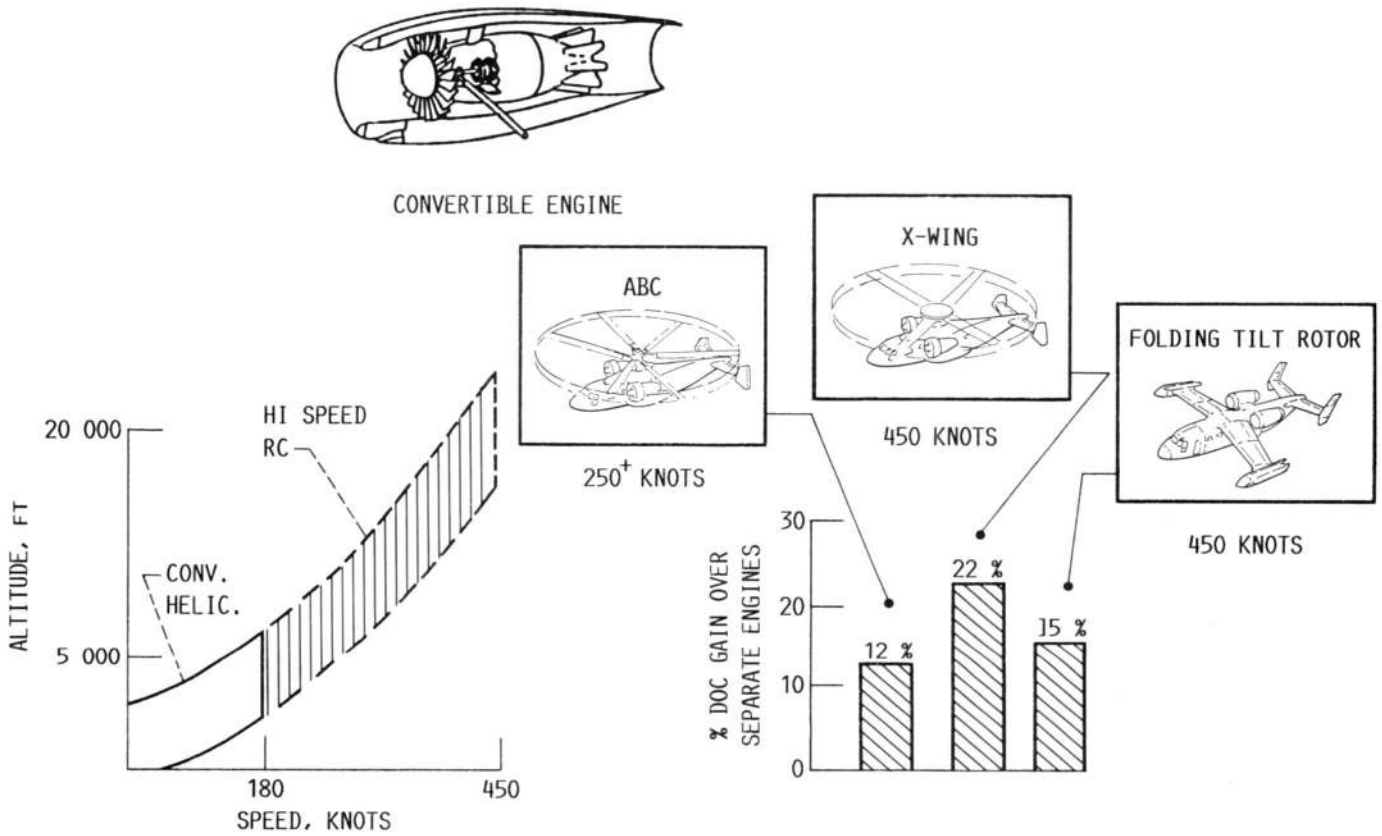

FIGURE 10. - ROTORCRAFT PROPULSION OPPORTUNITIES.

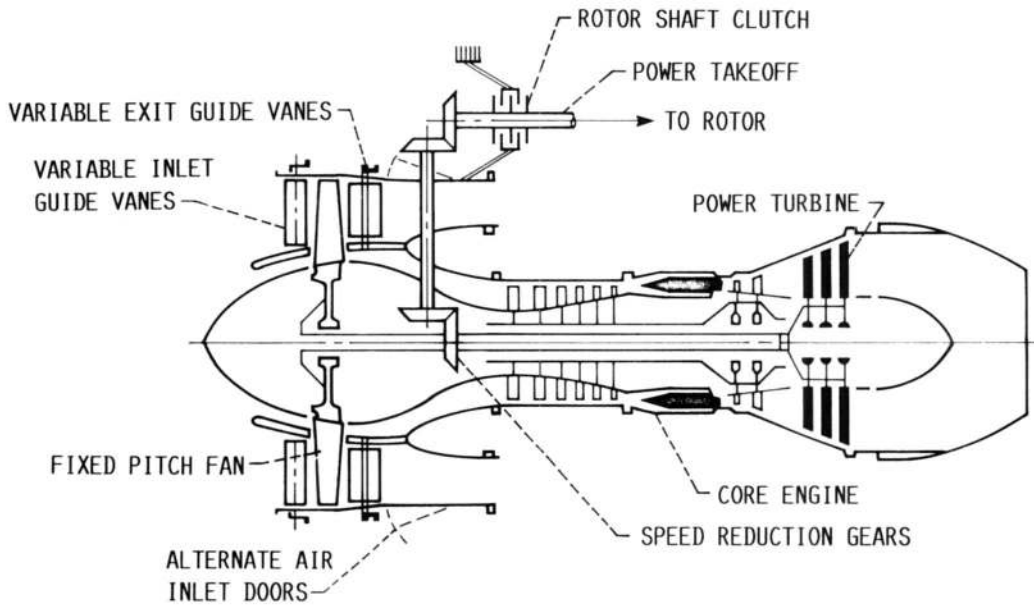

FIGURE 11.- CONVERTIBLE FAN/SHAFT ENGINE WITH VARIABLE GUIDE VANES.

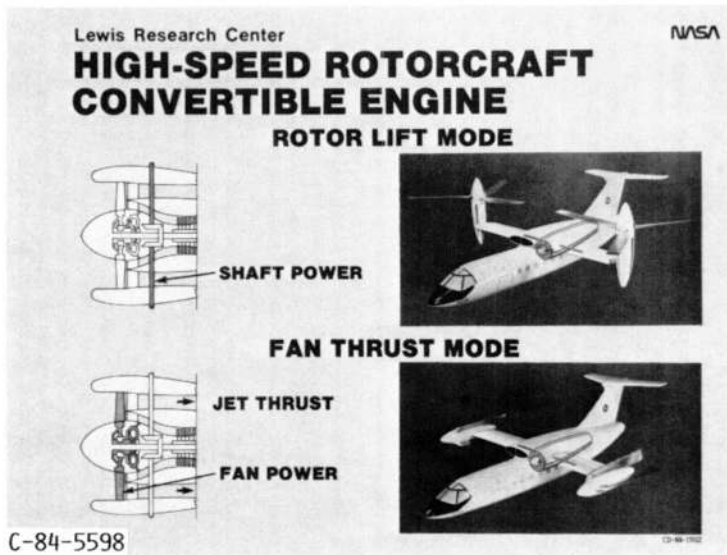
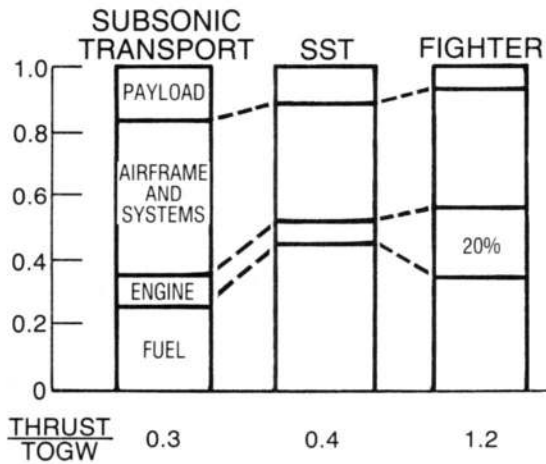

FIGURE 12. - TORQUE CONVERTOR TYPE CONVERTIBLE ENGINE.

AIRCRAFT WEIGHT BREAKDOWN



ENGINE T/W TREND

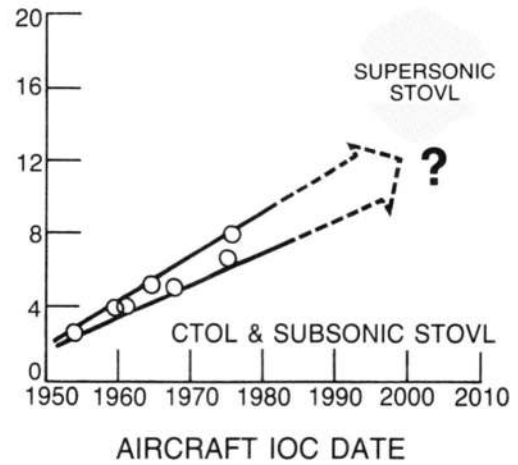

FIGURE 13.- IMPORTANCE OF FIGHTER ENGINE T/W.

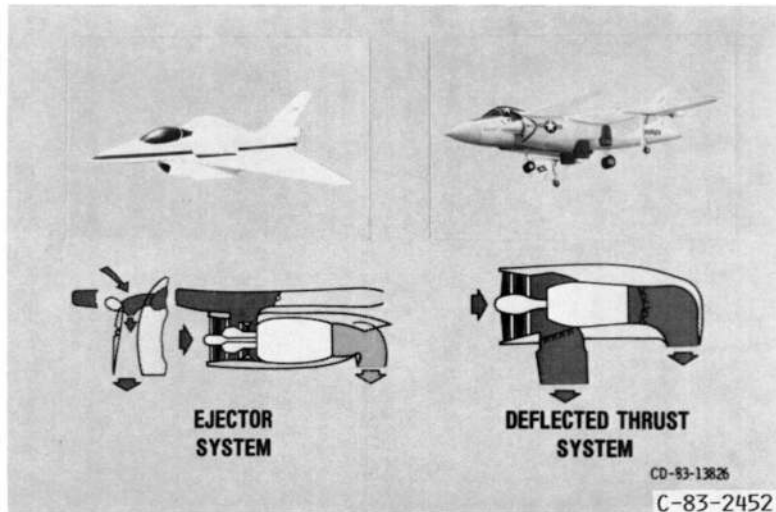

FIGURE 14.- SUPERSONIC V/STOL PROPULSION.

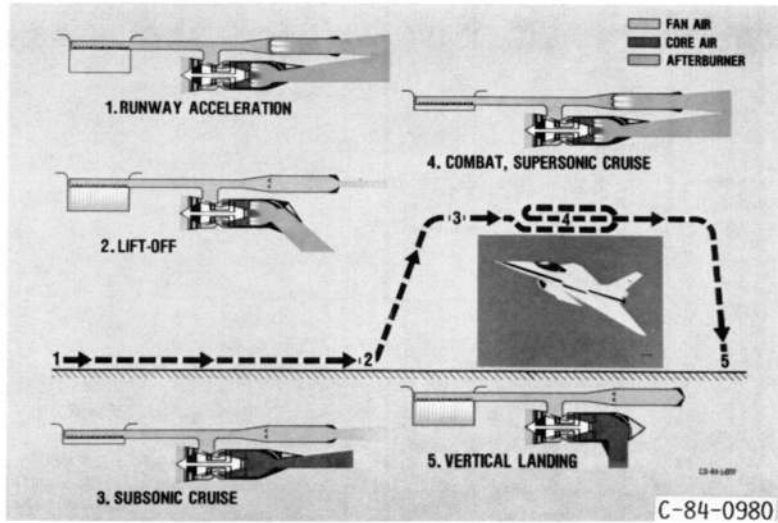

FIGURE 15. - EJECTOR PROPULSION MODES FOR SUPERSONIC STOVL.

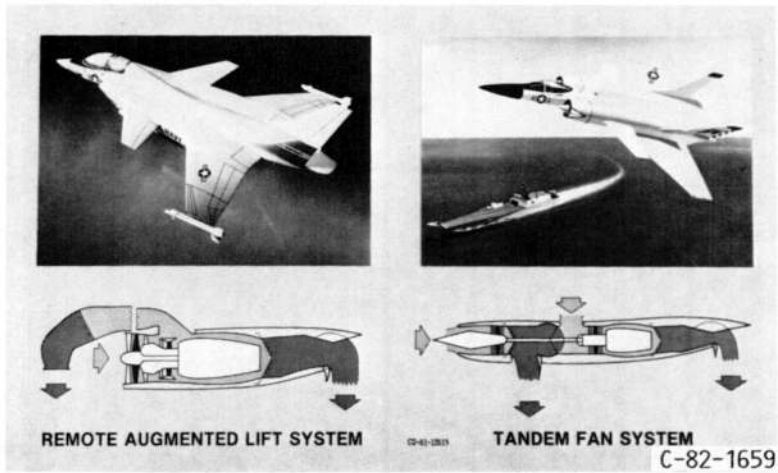

FIGURE 16. - SUPERSONIC V/STOL PROPULSION.

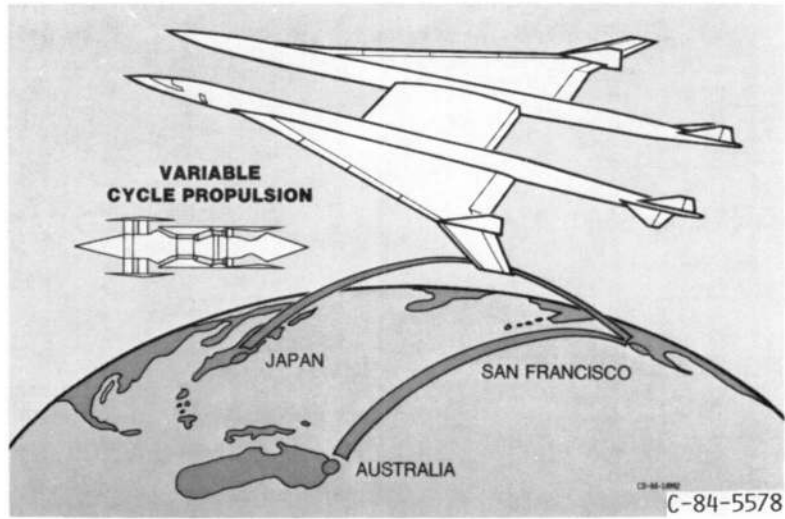
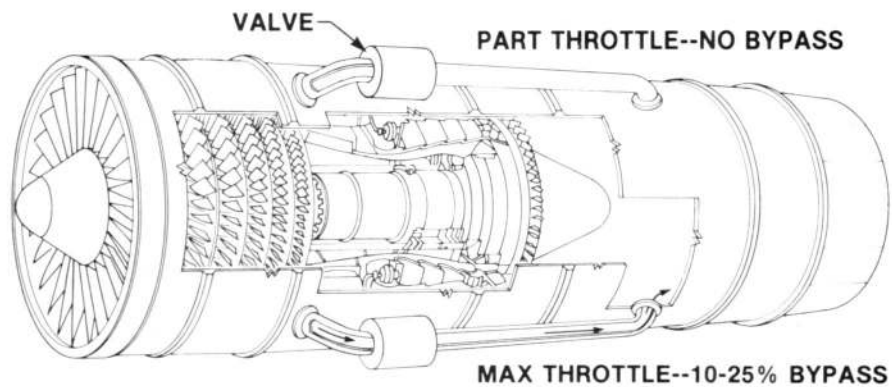

FIGURE 17. - LONG RANGE SUPERSONIC FLIGHT.



MAINTAINS AIRFLOW AT PART POWER

- HIGH COMPONENT & CYCLE EFFICIENCIES
- LOW SPILLAGE & BOATTAIL DRAG

SOURCE OF HIGH PRESSURE AIR FOR UNIQUE SYSTEMS

SINGLE SPOOL DRY TURBOJET

- 30% LOWER INITIAL AND MAINTENANCE COST
- LOWER SFC AT MAX POWER

BENEFITS FROM VERY HIGH TURBINE TEMP. TECH.

FIGURE 18.- TURBINE BYPASS ENGINE.

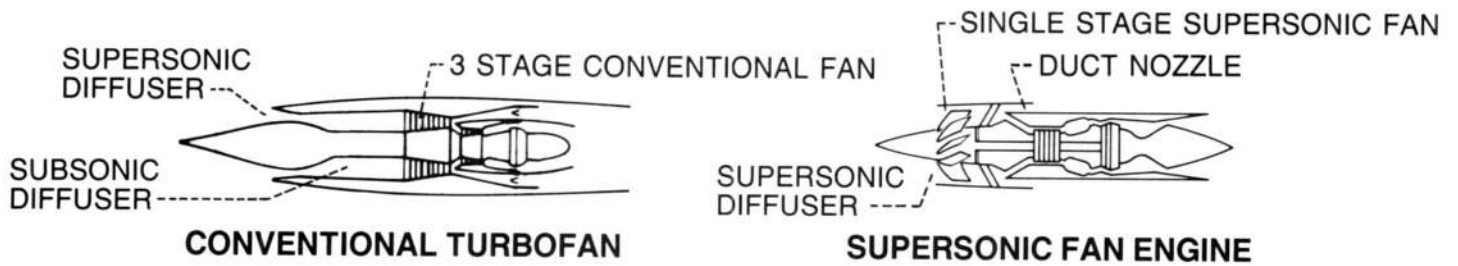

SUPERSONIC FAN ENGINE FEATURES

- SHORT, ALL SUPERSONIC INLET
- SINGLE STAGE SUPERSONIC FAN
- BPR DECREASES WITH M_0

IMPLICATIONS

- LOWER WEIGHT, LOWER INLET DRAG
- LOWER WEIGHT AND COST, RUGGED BLADING
- HIGHER CRUISE THRUST

WEIGHT: 15 TO 20% LOWER	CRUISE SFC: 10 TO 20% LOWER
--------------------------------	------------------------------------

FIGURE 19.- SUPERSONIC FAN ENGINE.

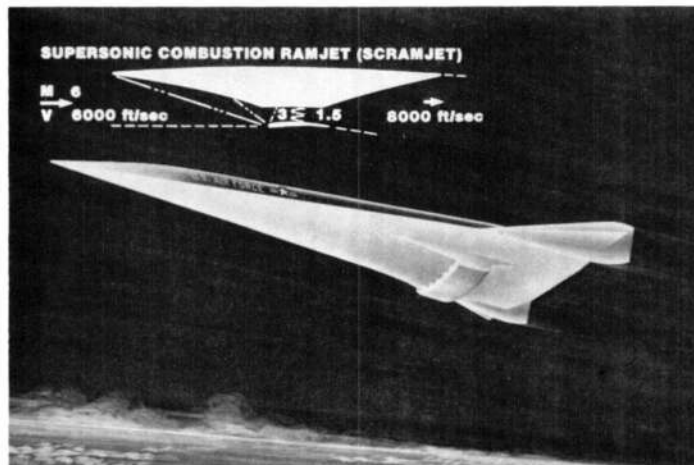

FIGURE 20. - SUPERSONIC CRUISE VEHICLE.

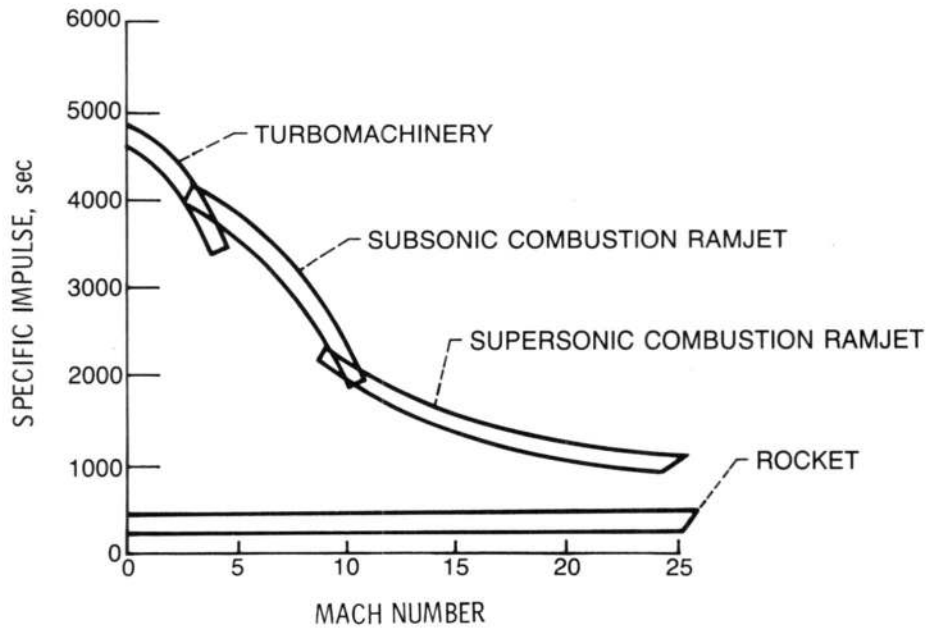

FIGURE 21.- PERFORMANCE OF AIR BREATHING ENGINES USING HYDROGEN FUEL.

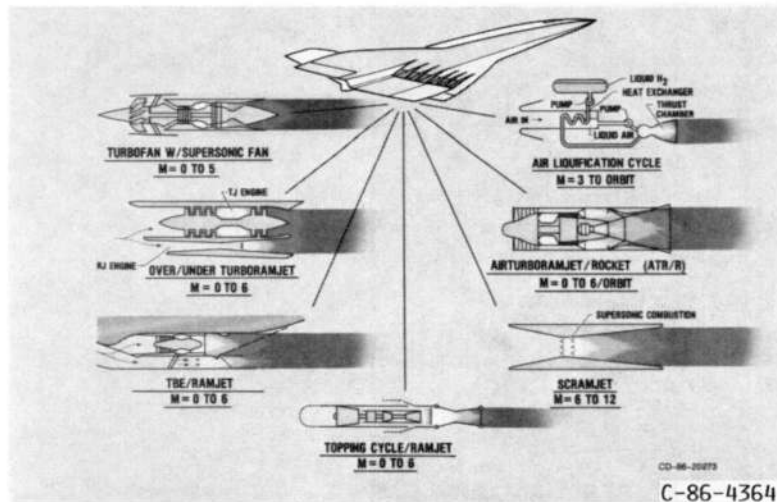

FIGURE 22.- PROPULSION STUDY CONCEPTS FOR HYPERSONIC AND HIGH-SUPERSONIC FLIGHT.

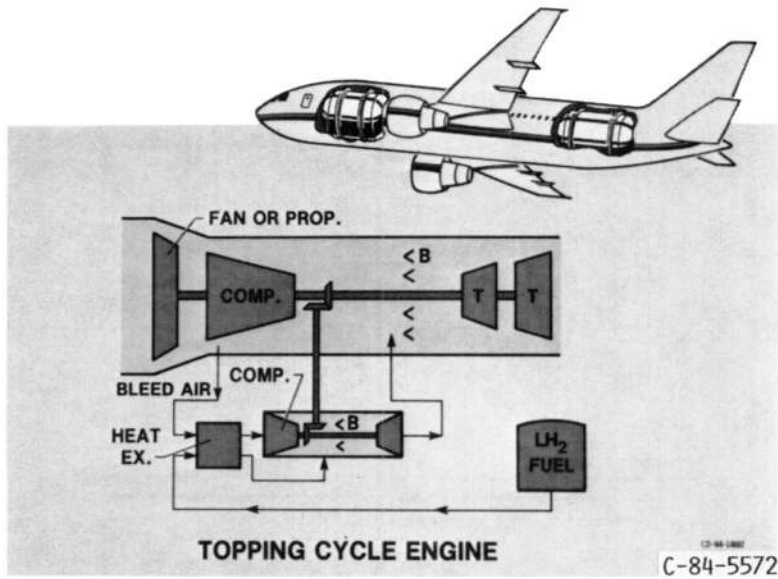

FIGURE 23. - EXPLOITING HYDROGEN FUEL.

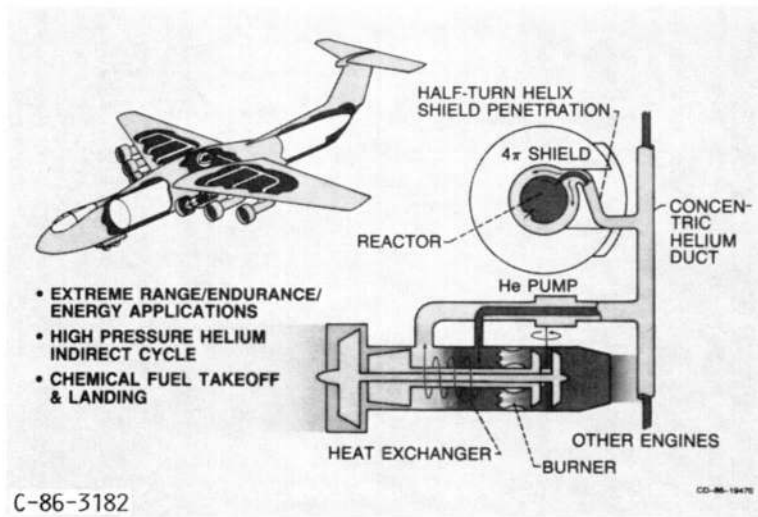

FIGURE 24. - NUCLEAR POWERED CRUISE AIRPLANE.

- TECHNICALLY FEASIBLE AND ATTRACTIVE FOR TOGW ≥ 1 Mib
- CRASH & AFTER HEAT REMOVAL SYSTEMS DESIGNED
- SAFETY NOT EXPERIMENTALLY VALIDATED
- POLITICAL/PSYCHOLOGICAL CONCERNS UNRESOLVED

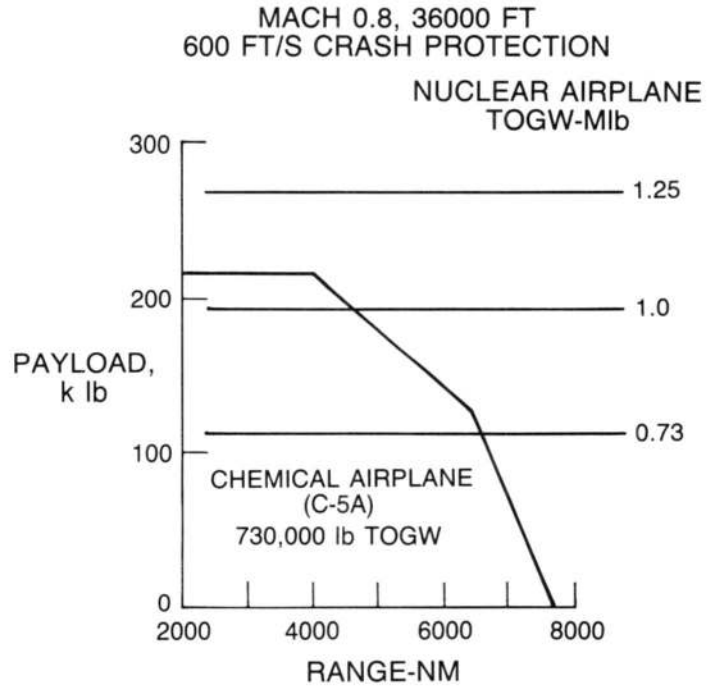

FIGURE 25.- NUCLEAR POWERED CRUISE AIRPLANE.

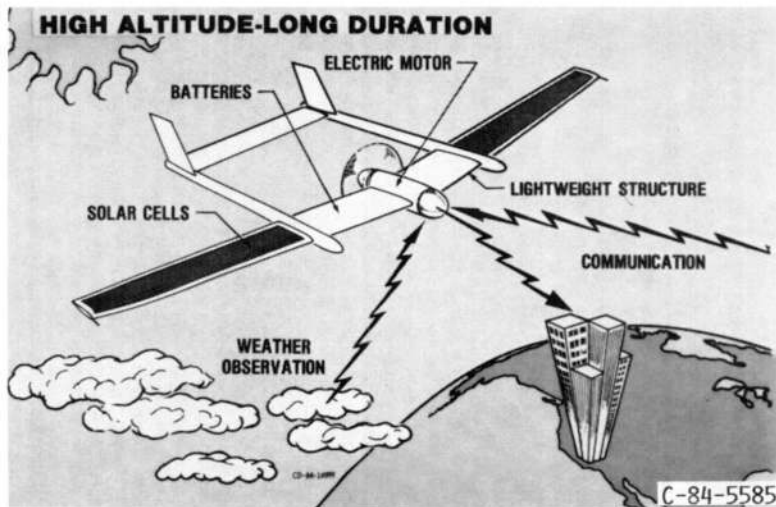

FIGURE 26. - SOLAR POWERED AIRCRAFT.

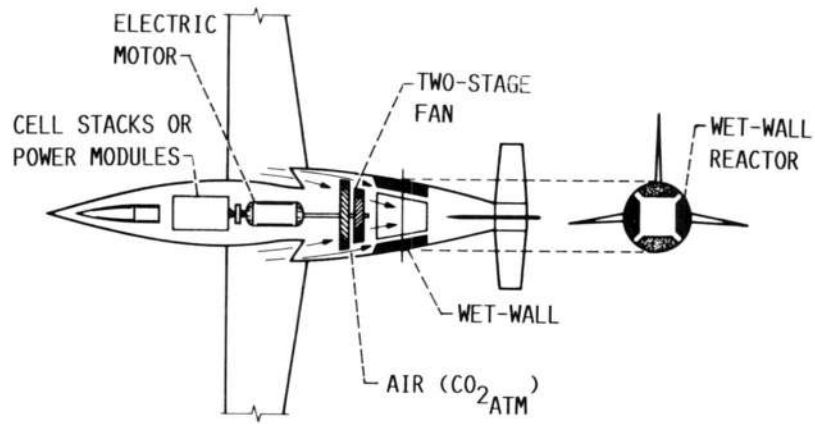

FIGURE 27.- FUEL-CELL PROPULSION.

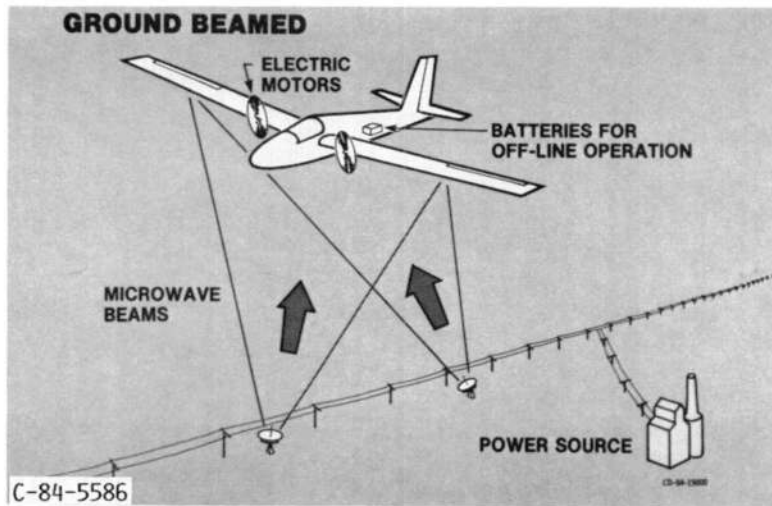

FIGURE 28. - MICROWAVE POWERED AIRCRAFT.

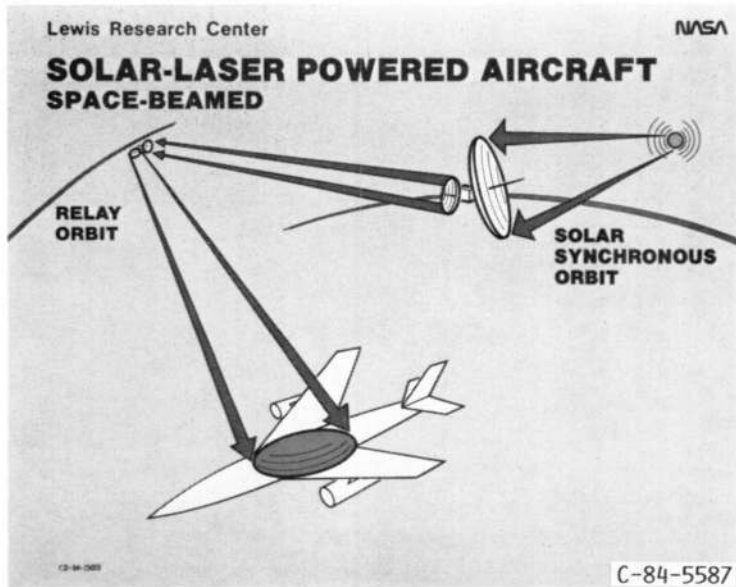

FIGURE 29. - SOLAR-LASER POWERED AIRCRAFT.

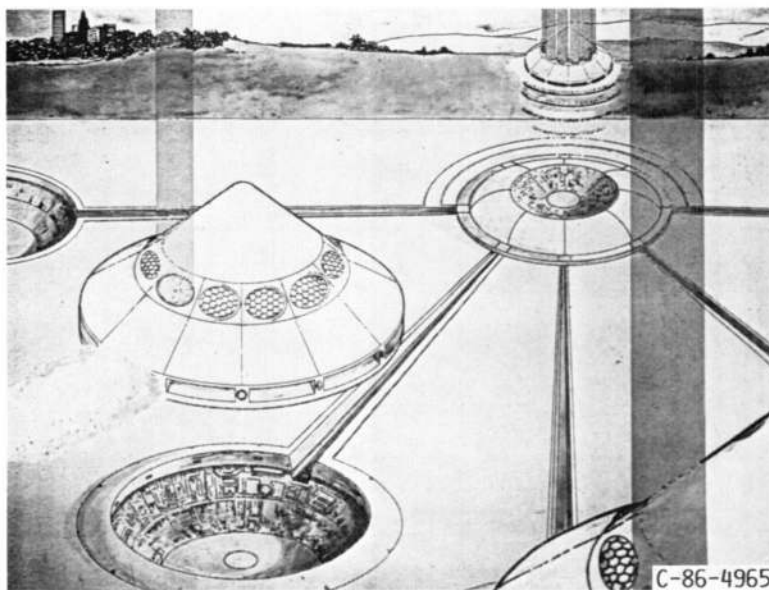

FIGURE 30. - MULTI-MODE, SPACE-BASED, LASER BEAMED
POWERED VEHICLE.

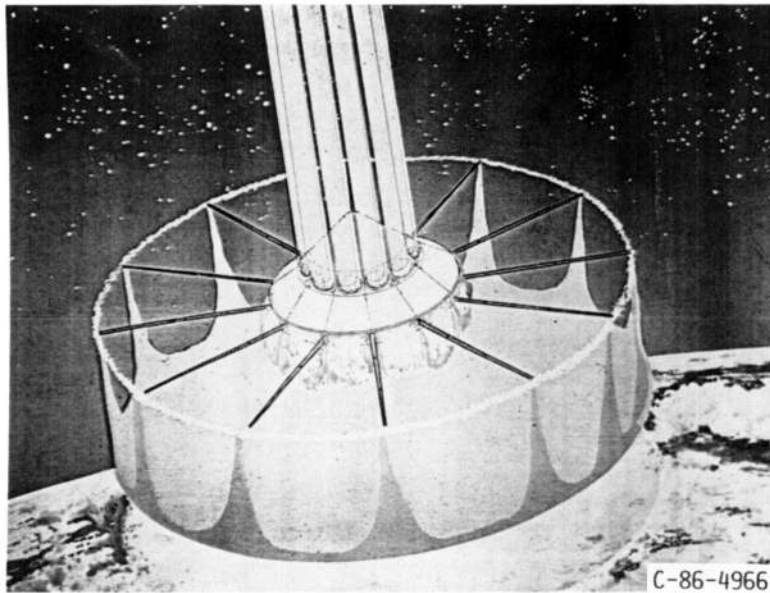

FIGURE 31. - HYPERSONIC MHD FANJET MODE.













	1990's	2000's	2010's
SUBSONICS	 ATP  VERY-HIGH BYPASS ENGINE  CONVERTIBLE ROTORCRAFT ENGINE  ROTARY ENGINE  ADV. SMALL TURBINE ENGINE		 BEAM POWER
SUPERSONICS	 HIGH-T/W SUPERSONIC ENGINE  SUPERSONIC STOVL ENGINE		 VARIABLE-CYCLE ENGINE
HYPERSONICS/ TRANSATMOSPHERICS	 TURBORAMJET  AIR-TURBORAMJET		 ADV CONCEPTS CD-85-18043

FIGURE 32. - FUTURE OPPORTUNITIES IN AEROPROPULSION.



1. Report No. NASA TM-88817	2. Government Accession No.	3. Recipient's Catalog No.	
4. Title and Subtitle Aeropropulsion Opportunities for the 21st Century		5. Report Date	
		6. Performing Organization Code- 505-69	
7. Author(s) William C. Strack		8. Performing Organization Report No. E-3177	
		10. Work Unit No.	
9. Performing Organization Name and Address National Aeronautics and Space Administration Lewis Research Center Cleveland, Ohio 44135		11. Contract or Grant No.	
		13. Type of Report and Period Covered Technical Memorandum	
12. Sponsoring Agency Name and Address National Aeronautics and Space Administration Washington, D.C. 20546		14. Sponsoring Agency Code	
		15. Supplementary Notes Prepared for the "Scenario for 21st Century Aero Engine Design" Seminar, sponsored by the Institution of Mechanical Engineers, Bristol, England, May 16-17, 1986.	
16. Abstract Examples of novel aeropropulsion system concepts are presented for subsonic through hypersonic applications offering large potential improvements. Collectively, these examples illustrate the revolutionary opportunities and challenges that could enable truly revolutionary aircraft capabilities in the future.			
17. Key Words (Suggested by Author(s)) Aeropropulsion opportunities Aeropropulsion concepts		18. Distribution Statement Unclassified - unlimited STAR Category 07	
19. Security Classif. (of this report) Unclassified	20. Security Classif. (of this page) Unclassified	21. No. of pages	22. Price*

— —

— —

National Aeronautics and
Space Administration

Lewis Research Center
Cleveland, Ohio 44135

Official Business
Penalty for Private Use \$300

SECOND CLASS MAIL

ADDRESS CORRECTION REQUESTED

LANGLEY RESEARCH CENTER



3 1176 01314 1149



Postage and Fees Paid
National Aeronautics and
Space Administration
NASA-451

NASA
