

Goddard



NATIONAL AERONAUTICS AND SPACE ADMINISTRATION  
WASHINGTON, D.C. 20546

REPLY TO  
ATTN OF: GP

MAY 1 1974

TO: KSI/Scientific & Technical Information Division  
Attn: Miss Winnie M. Morgan

FROM: GP/Office of Assistant General  
Counsel for Patent Matters

SUBJECT: Announcement of NASA-Owned U.S. Patents in STAR

In accordance with the procedures agreed upon by Code GP and Code KSI, the attached NASA-owned U.S. Patent is being forwarded for abstracting and announcement in NASA STAR.

The following information is provided:

U.S. Patent No. : 3,806,932  
Government or Corporate Employee : Philco - Ford, Palo Alto, CA  
Supplementary Corporate Source (if applicable) : Westinghouse Corp., Pitts., PA  
NASA Patent Case No. : FSC-11,446-1

NOTE - If this patent covers an invention made by a corporate employee of a NASA Contractor, the following is applicable:

YES  NO

Pursuant to Section 305(a) of the National Aeronautics and Space Act, the name of the Administrator of NASA appears on the first page of the patent; however, the name of the actual inventor (author) appears at the heading of column No. 1 of the Specification, following the words "...with respect to an invention of ..."

*Bonnie L. Woerner*

Bonnie L. Woerner  
Enclosure

[54] AMPLITUDE STEERED ARRAY

[75] Inventors: *Wilbur* Fred J. Dietrich, Palo Alto; George *W.S.* J. Koloboff, Foster City, both of Calif.; Robert J. Martel, Bel. Air; Chester C. Johnson, Lanham, both of Md.

[73] Assignee: The United States of America as represented by the Administrator of the National Aeronautic and Space Administration, Washington, D.C.

[22] Filed: June 15, 1972

[21] Appl. No.: 263,230

[52] U.S. Cl. .... 343/100 SA, 343/100 ST, 343/854, 343/DIG. 2

[51] Int. Cl. .... H01q 3/26

[58] Field of Search ..... 343/100 ST, 100 SA, 854, 343/DIG. 2

[56] References Cited

UNITED STATES PATENTS

3,044,063	7/1962	Russell	343/100 SA
3,531,803	9/1970	Rosen et al.	343/100 ST
3,707,719	12/1972	Mark	343/100 SA

Primary Examiner—Maynard R. Wilbur  
 Assistant Examiner—Richard E. Berger  
 Attorney, Agent, or Firm—Robert F. Kempf; John H. Warden; John R. Manning

[57] ABSTRACT

A spin stabilized satellite has an electronically despun antenna array comprising a multiplicity of peripheral antenna elements. A high gain energy beam is established by connecting a suitable fraction or array of the elements in phase. The beam is steered or caused to scan by switching elements in sequence into one end of the array as elements at the other end of the array are switched out. The switching transients normally associated with such steering are avoided by an amplitude control system. Instead of abruptly switching from one element to the next, a fixed value of power is gradually transferred from the element at the trailing edge of the array to the element next to the leading edge. Thus, as the satellite rotates, power is reduced on one element and power is increased on the other element thereby avoiding switching transients and maintaining constant total array power at all times. In terms of the beam, this action smoothly advances the energy and array phase center around the satellite whereas in a conventional switching system the energy and array phase center are caused to jump around the satellite in steps. Such phase discontinuities in particular can cause serious degradation to the performance of communication systems passing phase modulated data.

10 Claims, 11 Drawing Figures

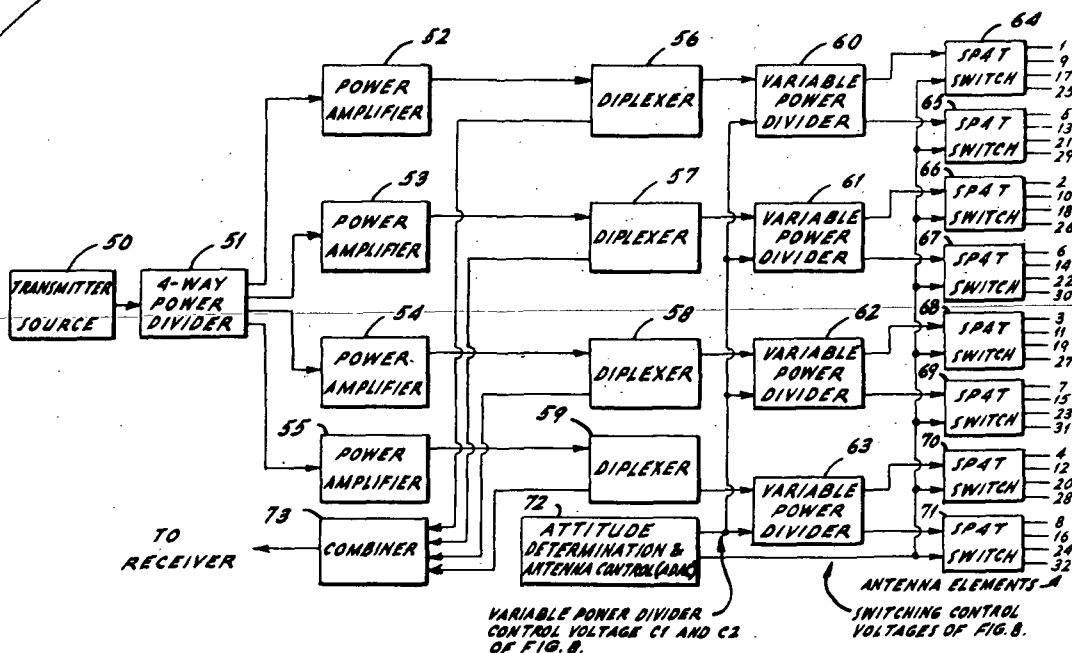

3,806,932

(NASA-Case-GSC-11446-1) AMPLITUDE STEERED  
 ARRAY Patent (NASA) 8 p CSCI 09A  
 N74-20860

00/09  
 Unclas  
 36171

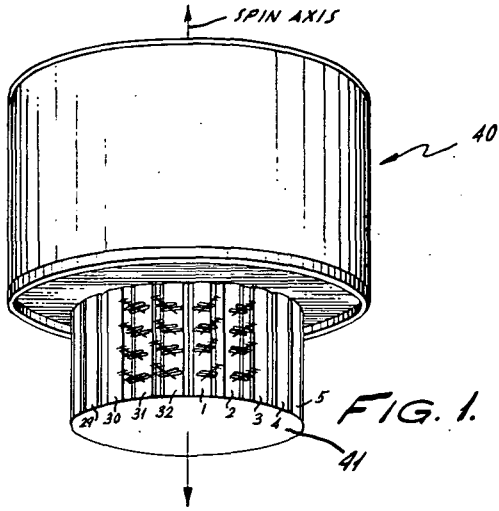

FIG. 1.

FIG. 2.

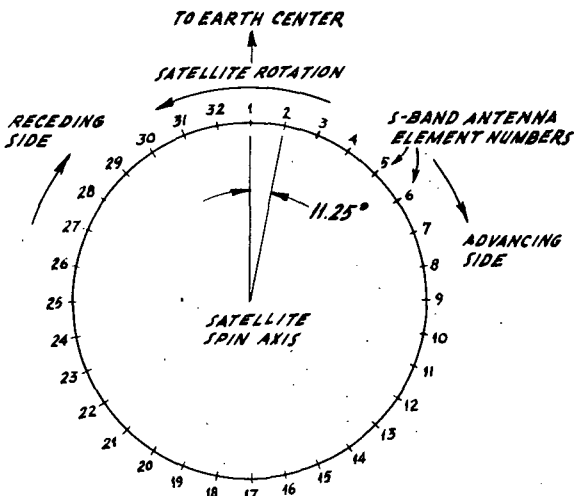
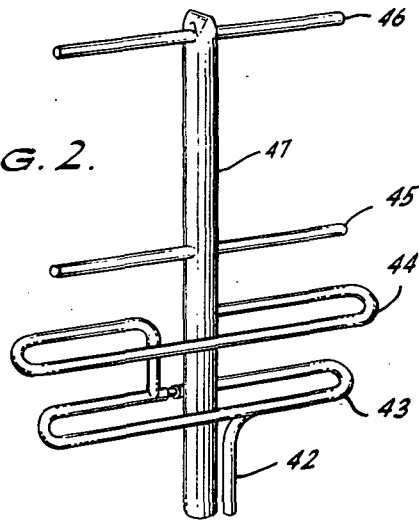

FIG. 3.

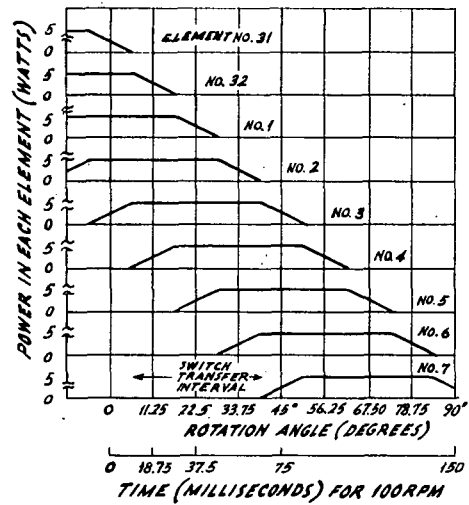

FIG. 4.

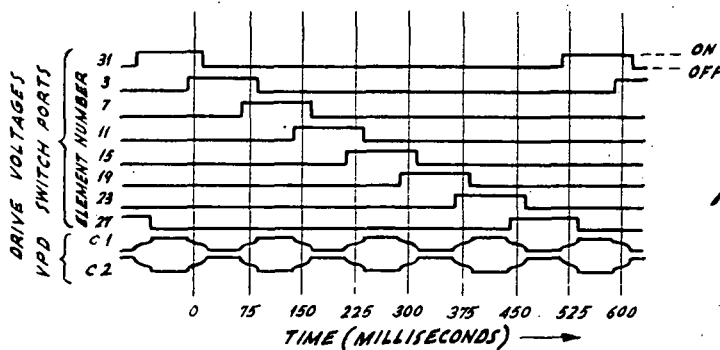

FIG. 8.

FIG. 5.

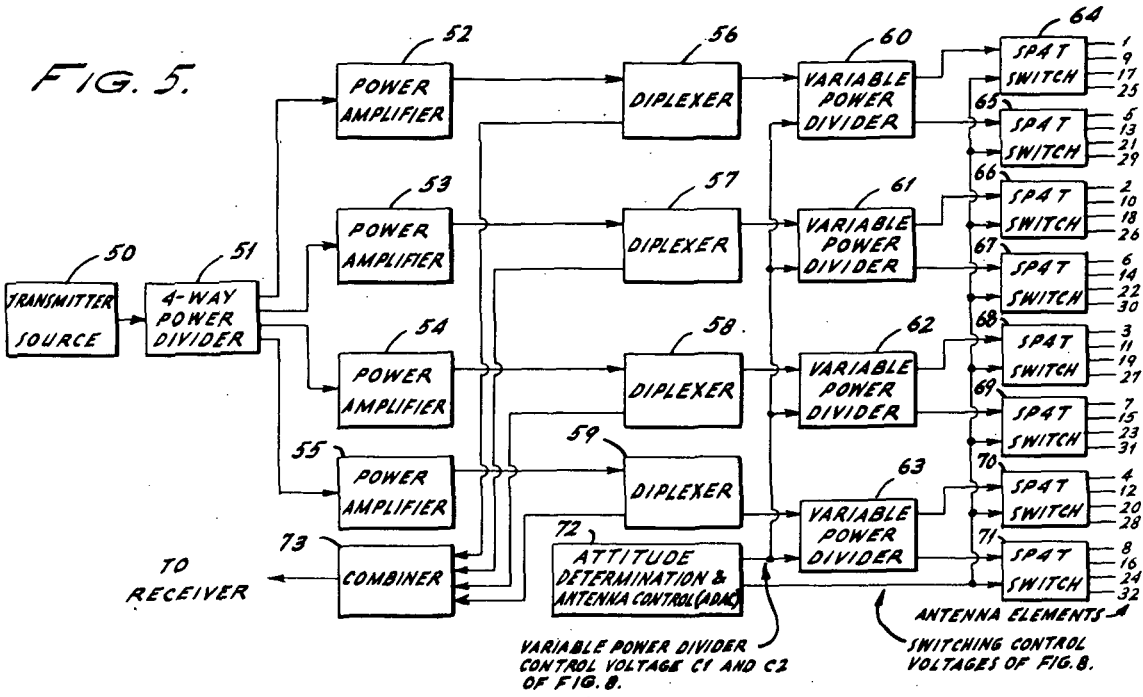

FIG. 6.

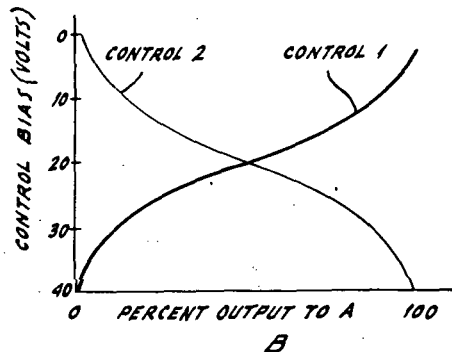
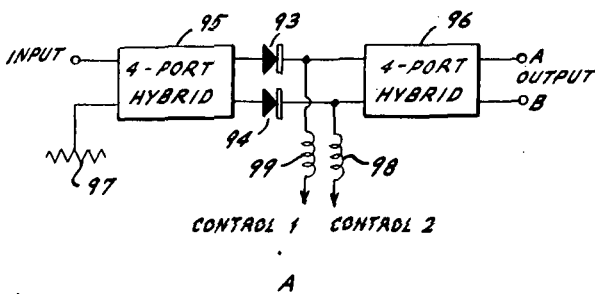
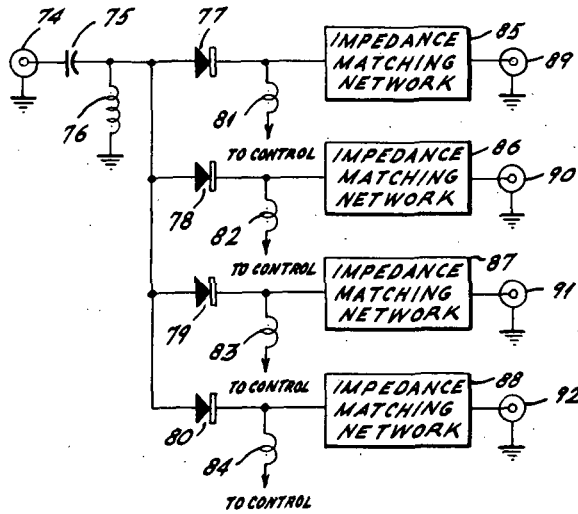
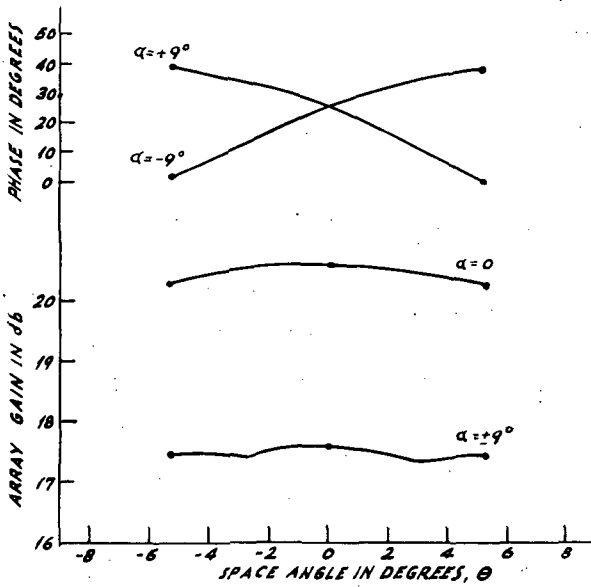
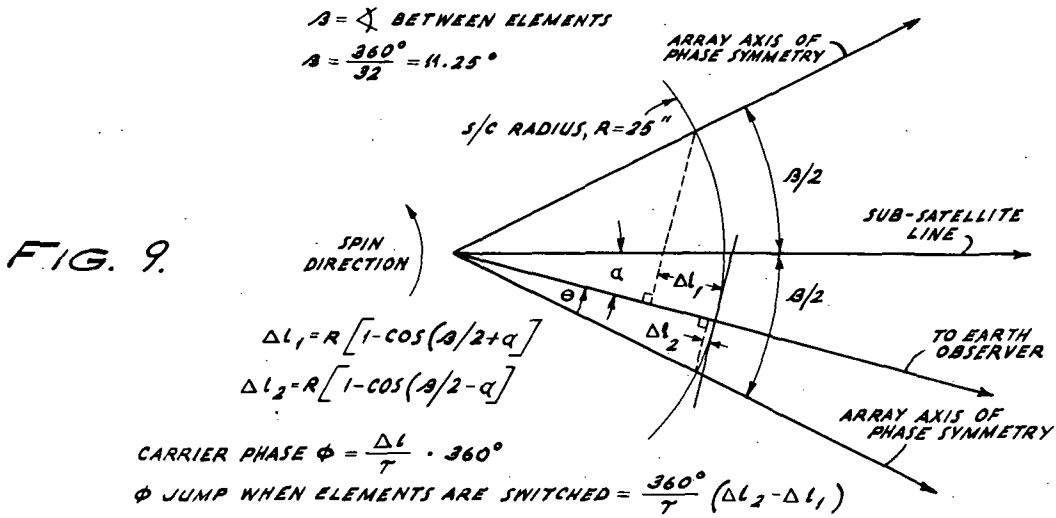
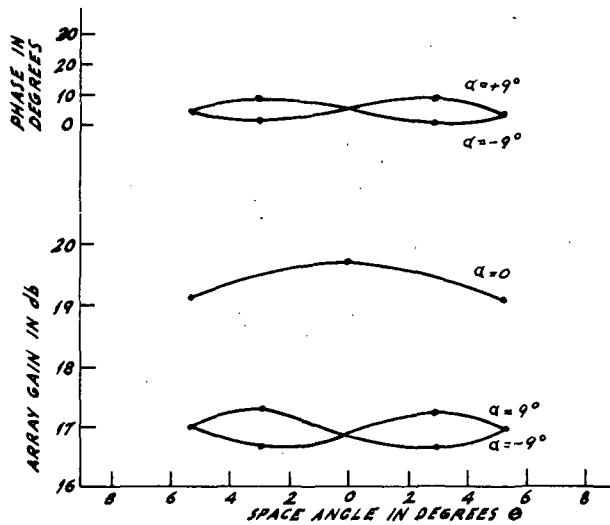

FIG. 7.



**FIG. 10.**

**FIG. 11.**



## AMPLITUDE STEERED ARRAY

## BACKGROUND OF THE INVENTION

The invention described herein was made in the performance of work under a NASA contract and is subject to the provisions of Section 305 of the National Aeronautics and Space Act of 1958, Public Law 85-568 (72 Stat. 435; 42 U.S.C. 2457).

Satellites are stabilized in space by being caused to spin. For a synchronous equatorial orbit, the spin axis is aligned with the spin axis of earth thereby causing the satellite to maintain a fixed orientation with respect to earth. If a high gain antenna is mounted on the satellite to provide communications with ground based stations, the antenna will be required to scan at the satellite rotation rate. Such an antenna is said to be despun when its scan rate exactly equals the satellite spin rate. Thus a despun antenna can include a high gain array that is caused continuously to point toward earth.

If a conventional antenna with a mechanical scanning device is mounted on a satellite, it has been found that the forces involved may in some cases adversely affect stability. Where the satellite carries a high resolution optical system, induced vibration can be a problem. Recurring bearing problems have resulted from operation in the harsh space environment. Accordingly, electronically scanned antennas have been developed to avoid some of the problems associated with mechanical scanning.

The most common system employed at the higher or microwave frequencies comprises a ring array of antenna elements distributed about the periphery of the satellite. The ring is concentric with the spin axis. One method commonly employed to scan such an array is to vary or modulate the phase of the energy fed to the individual antennas. Suitably phased signals will generate a beam that has the required characteristics and scans at the desired rate. However, in an antenna steered exclusively by phase shifters, each element must be continuously visible from the desired direction of the beam. This is often impractical to implement, particularly where a high gain array is to be employed. Also, since all elements must be continuously in view of the observer, serious mechanical constraints are imposed as to the location of such an array on the satellite structure. Accordingly, many prior art antennas employ a combination of phase shifting and element switching to achieve the desired scanning.

It has been found that if a suitable number of antenna elements is included in an array, the element spacing can be made such that when a small fraction or segment of the total number of elements is excited with an appropriate phase distribution, a suitable beam shape results. To scan the beam, antenna elements are sequentially switched into the driven segment as elements at the other end of the driven segment are switched out. Thus, the driven segment advances around the satellite periphery as it rotates, thereby keeping the driven segment in a relatively constant position with respect to earth.

Two techniques have been employed for such scanning. In the first system, the incremental switching disconnects an antenna element from the trailing edge of the driven segment simultaneously with the addition of an element to the leading edge of the segment. Thus, a constant number of elements always comprise the

driven segment. In the second system the switching sequence is such that first an element is switched into the segment at the leading edge, then an element is removed or disconnected from the trailing edge.

In actual practice it can be seen that in either prior art system as elements are incrementally added at one end of the driven segment and removed at the other end, the radiated energy and phase step or jump around the satellite in a discontinuous manner. While the resultant beam is always directed toward a particular point on the surface of earth, the incremental switching introduces signal phase discontinuities into the communications link. If a phase modulated signal structure is employed in the communications system, these discontinuities can have a serious effect on link stability and performance. In fact, phase lock can be lost for an appreciable fraction of time.

## SUMMARY OF THE INVENTION

It is an object of the invention to provide an amplitude steered antenna array that will closely approximate the performance of a true electronically steered phased array.

It is a further object to steer a high-gain multiple-element antenna by means of amplitude variations only, all elements being driven in the same phase.

It is a still further object to steer such an array without introducing switching discontinuities.

These and other objects are achieved by accomplishing antenna element switching during intervals when no power is being applied to the elements being switched.

The antenna array comprises a number of elements spaced around the satellite periphery. The array is designed so that when a small group or segment of adjacent elements is excited with r-f energy from a common source, the desired radiated beam pattern results. The array is scanned by gradually transferring power from the receding element in the driven segment to the element next to the leading edge of the driven segment. Thus, constant power is applied to the array at all times and the beam is smoothly scanned around the satellite.

## BRIEF DESCRIPTION OF THE DRAWING

FIG. 1 shows a satellite with its scanned communications antenna array;

FIG. 2 shows the detail of the individual sub array antenna elements;

FIG. 3 shows the antenna element array geometry in terms of the scanning sequence;

FIG. 4 is a timing diagram showing system operation;

FIG. 5 is a block diagram showing the amplitude steering system;

FIG. 6 shows the details of the single pole four throw (SP4T) switches of FIG. 5;

FIG. 7 shows the details of the variable power dividers of FIG. 5;

FIG. 8 shows the operating waveforms of one channel of the FIG. 5 system;

FIG. 9 shows the geometry of motion of the array phase center of a conventional switched array;

FIG. 10 shows amplitude and phase received on the ground from a conventional switched array as a function of spacecraft station; and

FIG. 11 shows the amplitude and phase received on the ground from an amplitude-steered array as a function of spacecraft rotation.

### DESCRIPTION OF THE PREFERRED EMBODIMENT

FIG. 1 shows a satellite 40 that may be spin stabilized by means, not shown, that are well known in the art. The communications antenna array is distributed around the outside of the lower portion 41. The satellite 40 may contain sensors, power supplies, and other electronic equipment not shown. The antenna portion, 41 of the satellite comprises 32 panels each containing a 4-antenna sub array. FIG. 2 presents a detailed showing of each antenna sub array. Coaxial feed line 42 drives folded dipole elements 43 and 44. Parasitic directors 45 and 46 act in combination with the driven elements to provide substantial gain and directivity. Driven elements and directors are suitably supported on support mast 47 which, in turn, is supported in perpendicular relation on one of the 32 panels shown in FIG. 1. The panel surface provides a ground plane for the sub array. Four sub arrays are mounted on each panel. They are spaced and driven so as to generate a combined radiation pattern having the desired spatial distribution along the satellite spin axis. Since the four sub arrays on each panel are connected in an invariant manner, they will be regarded as a unit and each panel will hereinafter be referred to as a single antenna element.

FIG. 3 shows the relationship of the 32 elements located around the periphery of the antenna portion 41 of the satellite. The satellite in this view is considered to spin counter clockwise and the antenna element switching sequence is in a clockwise direction. For the arrangement shown, elements 32, 1, and 2 each receive 5 watts of energy while elements 31 and 3 receive 2.5 watts each to produce a 20 watt system. The antenna element spacing around the satellite periphery is adjusted so that the above power distribution produces the desired antenna pattern with its major lobe pointing toward earth. The antenna gain and beamwidth are optimized to illuminate earth with a high gain pattern. As the satellite spins, the element feed is advanced clockwise around the array. Initially the power distribution between elements 31 and 3 is shifted. The 5-watt input is maintained while the power to 3 is increased and the power to 31 is decreased. When element 3 reaches 5 watts and 31 reaches zero, the power applied to element 32 is decreased as the power to element 4 is increased.

The phase center jump in the conventional switch de-spin array occurs as a result of the geometry shown in FIG. 9. As can be seen there, the intersection of the array axis of symmetry, or phase center, with the spacecraft has a position relative to a point on earth which changes by as much as  $\Delta l_1$ , with time. When switching occurs, this position jumps suddenly by this amount, resulting in the phase patterns shown in FIG. 10. The difference in phase between the end points of a given earth edge curve, say  $\alpha = +9^\circ$ , represents the amount of phase jump which will occur when the elements are abruptly switched. When amplitude steering is employed, the antenna phase center remains stationary in space, resulting in the performance shown in FIG. 11 as a function of satellite rotation. It can be seen there that the beginning and end phases at  $\alpha = +9^\circ$ , for example, are the same, so no phase jump will occur when switching takes place.

The peak-to-peak phase ripple is also substantially reduced when amplitude steering is used, being  $9^\circ$  in FIG. 11, compared to  $40^\circ$  in FIG. 10. This is also desirable for communication system performance.

A partial timing diagram is shown in FIG. 4. The numbers are for an assumed spin of 100 r.p.m. Time zero for this diagram represents the instant outlined above where elements 31 and 3 are at 2.5 watts. It can be seen from this timing diagram that the slope or rate of change in power is related to the total number of elements and that the power-versus-time function is relatively gradual for any particular element. It takes 18.75 milliseconds to shift the power level over the 5-watt range. Actual element switching is performed during the time interval when no power is being transferred, thereby avoiding switching transients.

FIG. 5 is a block diagram of a four channel system used to accomplish the antenna element switching and power control. A transmitter source 50 provides signal energy to a 4-way power divider 51 which energizes a group of four power amplifiers 52 to 55. Each amplifier supplies 5 watts for a combined output of 20 watts. In the uppermost channel, amplifier 52 applies its output through diplexer 56 to variable power divider 60, the latter being illustrated in greater detail in FIG. 7. The variable power divider will, depending upon the control voltage applied, apply the 5 watt signal to one of two switches 64 or 65 or both. In operation it will gradually transfer the power from one switch to the other. The first single pole four throw (SP4T) switch 64, which is shown in greater detail in FIG. 6, switches antenna elements 1, 9, 17 and 25 while SP4T switch 65 switches antenna elements 5, 13, 21, and 29. Switches 65 through 71 switch the remainder of the elements as shown. Thus the 32 elements are switched by eight SP4T switches. Pairs of SP4T switches are operated from four variable power dividers, each of which operates at a constant input power level.

If the conditions of FIG. 4 are considered, time zero indicates the condition where power divider 62 has equal outputs to SP4T switches 68 and 69. Switch 68 energizes element 3 and switch 69 energizes element 31. Elements 32, 1, and 2 are all energized at a full 5 watts from switches 71, 64, and 66 respectively. Power divider 60 is controlled to pass all of its input to switch 64 while power divider 61 is controlled to apply all of its power to switch 66 and power divider 63 is controlled to apply all of its power to switch 71.

The switching and power divider functions are all generated and controlled by the attitude determination and antenna control circuits 72 (referred to hereinafter as ADAC). These circuits are conventional and will not be described in detail. Attitude determination is usually a photoelectric process. Photoelectric detectors sense the earth location as a function of satellite rotation. This measurement also precisely indicates the spin rate. Alternately the sun can be sensed and the information on earth location computed therefrom. From these data the antenna control signals are generated. As will be apparent hereinafter, from the description of FIGS. 6, 7 and 8, the single line interconnecting ADAC device 72 and the eight SP4T switches in representative of a 32 circuit cable, four circuits to each of the eight SP4T switches. Similarly, the single line interconnecting ADAC device 72 and the four variable power dividers is representative of an eight circuit cable, two circuits to each of the variable power dividers.

While the antenna beam foundation has been described in terms of a transmitted beam, the array will also function as a receiving antenna because the SP4T switches and variable power dividers are reciprocal devices. For a given antenna its receiving beam characteristics will approximate the transmitted beam characteristics. It is only necessary that the transmit and receive functions be separated slightly in frequency if it is desired to permit simultaneous operation or duplexing. Duplexers 56-59 are included in the FIG. 5 circuits to provide the receiver function. These duplexers are well known conventional frequency selective devices. At the transmitting frequency the duplexers connect the power amplifiers to the variable power dividers. At the receiver frequency the duplexers connect the variable power dividers to combiner 73. Signals received by the various antenna elements will be connected, in accordance with the controls applied to the SP4T switches and power dividers, to combiner 73, the output of which is applied to a suitable receiver.

FIG. 6 shows the nature of the SP4T switches 64-71. A common input terminal 74 receives signal energy from one of the two output terminals of one of the variable power dividers of FIG. 7 (i.e., from one of the output terminals, A or B, of FIG. 7). Terminal 74 is coupled through a network comprising d-c blocking capacitor 75 and shunt d-c return inductor 76 to PIN diodes 77-80. The diodes couple to output terminals 89-92 by way of impedance matching networks 85-88 which include d-c blocking capacitors. Diode control signals derived from ADAC device 72 are applied through isolating inductors 81-84. The characteristics of the PIN diodes 77-80 are such that when not biased they represent a high series impedance and will block transmission. When forward biased, in the range of 75 to 200ma., they represent a very low impedance and will pass r-f energy. The impedance matching networks are needed to correct for the physical discontinuity the diodes present in the r-f circuits. Thus in FIG. 6 if only diode 79 is forward biased, signals at 74 will be transferred only to output 91. In operation of any one SP4T switch the control circuits bias only one diode "on" at a time. Timing is controlled by ADAC device 72 so that the switching is accomplished during the interval when no r-f power is applied to the input terminal of the switch. Thus the switching action in the SP4T switches does not introduce transients into the signals being controlled.

FIG. 7 shows the nature of the variable power dividers 60-63. As shown in FIG. 7a two varactor diodes 93 and 94 couple two hybrids 95 and 96. The unused terminal on hybrid 95 is terminated in a matched load shown diagrammatically at 97. Isolation inductors 98 and 99 permit control bias to be applied to the varactor coupling diodes. The varactor diodes act as signal phase shifters and are operated with control voltages so that as the phase shift through one is increased, the phase shift through the other decreases. The two output signals at A and B will be a function of the relative phase of the signals fed into hybrid 96. For the condition of equal phase inputs, where each varactor operates at a 45° phase shift, the outputs will be equal and of the same phase. As the relative phase shifts vary the relative outputs will vary, and if the control signals have the proper amplitude the output signals will be of constant phase at all levels. As the phase shift in diode 93 approaches zero the phase shift in diode 94 approaches

90°. For this condition all (or substantially all) of the output power appears at one output terminal while none (or at least very little) appears at the other output terminal. If the diode phase conditions are reversed, the output shifts to the other output terminal.

FIG. 7b shows how the output amplitude varies as a function of diode bias. It will be noted that as the control biases vary, the power division between outputs A and B varies disproportionately. If the inverse control signals have a suitable shape, as shown in FIG. 7b (and in the waveforms C1 and C2 of FIG. 8), division of input between the two outputs will be a linear function of time.

FIG. 8 is a partial showing of the switching waveforms required for antenna scanning. These are generated by conventional circuits in the ADAC section. The bottom two waveforms C1 and C2 show the variable power divider control waveforms and would constitute the control 1 and control 2 signals of FIG. 7 as applied to variable power divider 62. The transition waveform is shaped so that the actual transfer of output in the variable power dividers is linear (or nearly linear) with time. The upper 8 waveforms of FIG. 8 are labelled in accordance with the antenna element activated through a SP4T switch by the upward-going portion of the waveform. The showing actually indicates the time sequence of element actuation or switching for the antenna elements associated with SP4T switches 68 and 69 of FIG. 5 (note the correspondence between the Element Numbers identified in FIG. 8 and the numbered output terminals of SP4T switches 68 and 69 of FIG. 5). The time zero shown corresponds to the time zero of FIG. 4. It can be seen that antenna element switching occurs when no power is being applied to the element. For example, when the waveform labelled 31 is in its lower position, element 31 is not energized. According to switch waveform 31, the element is switched on (forward diode bias applied) just prior to when variable power divider 62 shifts its input energy to SP4T switch 69. Then C1 and C2 cause power to be applied, increasing linearly (or nearly linearly) to 5 watts. At the appropriate time the power is reduced to zero power and element 31 is then switched off. This sequence applies to all elements in the array.

As shown by the overlap of the waveforms 31 and 3 both elements are on while the C1 and C2 waveforms transfer the signal power from element 31 to element 3.

Action similar to that described above occurs in each of the other three signal channels involving variable power dividers 60, 61, and 63, with the timing adjusted to produce the desired beam scanning. Thus the complete antenna array is scanned by means of purely amplitude control which results in a stationary array phase center to all earth observers, as well as a constant total power at all times with no abrupt gain or phase transients. This form of scanning has been extremely effective in maintaining the performance of the phase modulated communication channels.

While only one preferred embodiment has been shown, alternatives will occur to a person skilled in this art. For example, other than four r-f signal channels could be employed and more or less complex antenna arrays could be used, including deletion of the power amplifiers (52-55). Furthermore, while the concept has been applied to despun satellite antennas it could be applied to other systems such as large ground radar



or direction finding stations employing large multiple-element arrays. In addition, other transducers could be employed as for example those employed in sonar systems. If a sonar head contained a large number of transducers in a ring shaped array, they could be operated and excited to produce a rotating scanning beam in accordance with the foregoing principles. Still other applications will occur to those skilled in the related arts. It is intended that the scope of our invention be limited only by the following claims.

We claim:

1. A system for scanning a plurality of transducers located in a ring-shaped array, said system comprising: a common terminal, switching means for selectively and sequentially connecting transducers in said array to said common terminal so that only adjacent transducers in a segment of said array are connected to said common terminal at any given instant, control means operative on said switching means to cause said segment to scan around said array at a controlled rate, said segment including leading edge transducers and a trailing edge transducer, variable coupling means in cascade between said switching means and said terminal, means for increasing at a rate related to said controlled rate the coupling between said terminal and said leading edge transducer, and means for simultaneously decreasing at the same rate the coupling between said terminal and said trailing edge transducer, said switching means being actuated only when said coupling is at minimum.
2. The system of claim 1 wherein said transducers are antennas and said controlled rate is the scanning rate of the antenna array.
3. The system of claim 1 wherein said common terminal is energized by a power source and said scanning operates at a constant total power.

4. The system of claim 1 wherein said common terminal is connected to a receiver and said system operates as a receiving array.

5. The system of claim 1 wherein said common terminal is connected to a diplexer and said system operates simultaneously as a transmitting and a receiving array.

6. The system of claim 3 wherein said antennas are mounted in a ring on the periphery of a spin stabilized satellite and said controlled rate is selected to despin said antenna system.

7. In a despun antenna operated on a spin stabilized satellite, said antenna including an array of elements distributed to form a ring about the spin axis of said satellite, means for connecting a fraction of said elements into a segment of adjacent elements to produce a desired antenna pattern, said segment having a leading edge and a trailing edge, and means for switching elements into said leading edge of segment while switching elements out of said trailing edge of said segment at a rate equal to the spin rate of said satellite, the improvement comprising:

means for gradually introducing an element into said leading edge of said segment while simultaneously gradually removing an element from said trailing edge of said segment, said means for switching being operated during the interval when said elements are not actively associated with said segment.

8. The improvement of claim 7 wherein said means for gradually introducing and removing elements operates as a predetermined function of time.

9. The improvement of claim 8 wherein a power source connected to said antenna system applies constant power as a function of time.

10. The improvement of claim 8 wherein a power source connected to said antenna system maintains a stationary array phase center as a function of time.

\* \* \* \* \*

40

45

50

55

60

65

