

NORTH AMERICAN FAUNA



United States Department of the Interior
Fish And Wildlife Service

Contents

	Pages
Abstract	1
Introduction	2
Scope and intent	2
Approach taken in this review	2
Limitations of the available data	2
Delimitation of species	4
Consideration of admixture in delimiting species	6
Delimiting subspecies of <i>Canis lupus</i>	6
Biology of the Species	10
Taxonomic background on wolf species and subspecies	10
History and overview of the genus <i>Canis</i>	10
<i>Canis</i> in North America	10
Red wolf	12
Gray wolf subspecies	12
Ecology, behavior, prey, and habitat	13
Taxonomic Evaluation and Discussion	13
Species limits of <i>Canis lupus</i> relative to eastern wolf	14
Morphometrics	14
Autosomal microsatellite DNA	15
Single-nucleotide polymorphisms	15
Mitochondrial and Y-chromosome haplotypes	19
Functional gene loci	25
Conclusions on species limits of <i>Canis lupus</i> relative to eastern wolf	25
Species limits of <i>Canis lupus</i> with respect to red wolf	27
Morphometrics	28
Autosomal microsatellite DNA	28
Single-nucleotide polymorphisms	28
Mitochondrial DNA and Y-chromosome haplotypes	28
Functional gene loci	29
Diet	29
Conclusions on species limits of <i>Canis lupus</i> with respect to red wolf	29
Species limits within the coyote clade	29
Morphometrics	29
Autosomal microsatellite DNA	29
Single-nucleotide polymorphisms	30
Mitochondrial DNA and Y-chromosome haplotypes	31
Functional gene loci	31
Conclusions on species limits within the coyote clade	31
Relationship of red wolf and eastern wolf	32
Morphometrics	32
Single-nucleotide polymorphisms	32
Functional gene loci	32
Geographic gaps in sampling	32
Hypotheses involving hybridization	33
Phylogenetic relationships	33



Conclusions on the relationship of red wolf and eastern wolf	33
Nomenclatural issues	34
The subspecies of <i>Canis lupus</i>	34
<i>Canis lupus baileyi</i> (Mexican wolf)	34
<i>Canis lupus arctos</i> (Arctic wolf)	37
<i>Canis lupus occidentalis</i> (northern timber wolf)	38
<i>Canis lupus nubilus</i> ("plains" wolf)	39
A General Evolutionary Interpretation	42
Final Comments and Recommendations	42
Acknowledgments	44
References	44
Appendix: Summaries of Taxonomically Relevant Information in	
Morphological and Genetic Studies	48
Morphology	48
Summary of studies on morphology	52
Autosomal microsatellite DNA	52
Summary of studies of autosomal microsatellite DNA	56
Single-nucleotide polymorphisms	56
Mitochondrial DNA	57
Summary of studies of mtDNA	63
Y-chromosome haplotypes	63
Summary of studies of Y-chromosome DNA	66
Functional gene loci	66



Monograph

An Account of the Taxonomy of North American Wolves From Morphological and Genetic Analyses

Steven M. Chambers,* Steven R. Fain, Bud Fazio, Michael Amaral

S.M. Chambers

Division of Ecological Services, U.S. Fish and Wildlife Service, P.O. Box 1306, Albuquerque, New Mexico 87103

S.R. Fain

National Forensics Laboratory, U.S. Fish and Wildlife Service, 1490 East Main Street, Ashland, Oregon 97520

B. Fazio

Mexican Wolf Recovery Program, New Mexico Ecological Services Field Office, U.S. Fish and Wildlife Service, 2105 Osuna Road NE, Albuquerque, New Mexico 87113

Present address: Wildlife and Sport Fish Restoration Program, U.S. Fish and Wildlife Service, P.O. Box 1306, Albuquerque, New Mexico 87103

M. Amaral

New England Field Office, U.S. Fish and Wildlife Service, 70 Commercial Street, Suite 300, Concord, New Hampshire 03301

Abstract

The available scientific literature was reviewed to assess the taxonomic standing of North American wolves, including subspecies of the gray wolf, *Canis lupus*. The recent scientific proposal that the eastern wolf, *C. l. lycaon*, is not a subspecies of gray wolf, but a full species, *Canis lycaon*, is well-supported by both morphological and genetic data. This species' range extends westward to Minnesota, and it hybridizes with gray wolves where the two species are in contact in eastern Canada and the Upper Peninsula of Michigan, Wisconsin, and Minnesota. Genetic data support a close relationship between eastern wolf and red wolf *Canis rufus*, but do not support the proposal that they are the same species; it is more likely that they evolved independently from different lineages of a common ancestor with coyotes. The genetic distinctiveness of the Mexican wolf *Canis lupus baileyi* supports its recognition as a subspecies. The available genetic and morphometric data do not provide clear support for the recognition of the Arctic wolf *Canis lupus arctos*, but the available genetic data are almost entirely limited to one group of genetic markers (microsatellite DNA) and are not definitive on this question. Recognition of the northern timber wolf *Canis lupus occidentalis* and the plains wolf *Canis lupus nubilus* as subspecies is supported by morphological data and extensive studies of microsatellite DNA variation where both subspecies are in contact in Canada. The wolves of coastal areas in southeastern Alaska and British Columbia should be assigned to *C. lupus nubilus*. There is scientific support for the taxa recognized here, but delineation of exact geographic boundaries presents challenges. Rather than sharp boundaries between taxa, boundaries should generally be thought of as intergrade zones of variable width.

Keywords: genetics; morphometrics; taxonomy; wolf

Received: April 15, 2011; Accepted: June 22, 2012; Published Online Early: August 2012; Published: October 2012

Citation: Chambers SM, Fain SR, Fazio B, Amaral M. 2012. An account of the taxonomy of North American wolves from morphological and genetic analyses. *North American Fauna* 77:1–67. doi:10.3996/nafa.77.0001

Copyright: All material appearing in *North American Fauna* is in the public domain and may be reproduced or copied without permission unless specifically noted with the copyright symbol ©. Citation of the source, as given above, is requested.

The findings and conclusions in this article are those of the author(s) and do not necessarily represent the views of the U.S. Fish and Wildlife Service.

* Corresponding author: steve_chambers@fws.gov

Subject Editor: Sandra Talbot, U.S. Geological Survey, Anchorage, Alaska



Introduction

The taxonomy of North American members of the genus *Canis* has a complicated and controversial history. This is not surprising in light of their variability in size, proportions, and pelage; large geographic ranges; tendency of various forms to interbreed; and their extirpation over large areas beginning early in the period of colonization by Europeans. Members of North American *Canis*, exclusive of coyotes *Canis latrans*, are commonly referred to as “wolves.” For these North American wolves, 31 published names for subspecies or species are available (Hall and Kelson 1959; Table 1 of this paper). The two most recent comprehensive taxonomic reviews based on morphology both recognize 2 species, *Canis lupus* (gray wolf) and *Canis rufus* (red wolf), but differ in that they recognize as many as 27 (Hall [1981], based primarily on Goldman [1944]), or as few as 8 subspecies (Nowak 1995) for the 2 species collectively.

The first of many studies of *Canis* using molecular genetic markers (Lehman et al. 1991; Wayne and Jenks 1991) raised new challenges to the general taxonomic scheme (Goldman 1944) that had stood for almost 50 y. In particular, the possible role of coyotes in the ancestry of both the red wolf and what had been considered gray wolves in the Great Lakes region generated new controversy. Development of even more powerful genetic markers has led to new, highly controversial interpretations, such as the distinctiveness of wolves of the Great Lakes region from gray wolves and the possibility that they are conspecific with red wolves (Wilson et al. 2000), a proposal rejected by others based on genetics (e.g., Koblmüller et al. 2009a) and morphometrics (e.g., Nowak 2009). Other controversies include whether the current Great Lakes wolf population is evolutionarily representative of the historical population (Leonard and Wayne 2008), the taxonomic identity of Minnesota wolves (Nowak 2009), the historical northern boundary of the Mexican wolf *Canis lupus baileyi* (Leonard et al. 2005), and the taxonomic identity of wolves of Pacific coastal regions (Muñoz-Fuentes et al. 2009). The lack of consensus among researchers on so many important issues related to the taxonomy of North American wolves prompted the present review.

Scope and intent

The purpose of this review is to explore the scientific support in the currently available scientific literature for 1) recognizing any taxonomic subdivisions, including species and subspecies, of North American wolves; 2) recommending at least general geographic boundaries for any recognized taxa, either species or subspecies; and 3) recommending additional research and analysis that would improve

the scientific basis for evaluating the taxonomy of wolves.

This review provides the authors' views only on whether the validity of each taxon is supported by a preponderance of evidence from the relevant, available scientific literature. It is important to emphasize the following points about the scope of this review:

- 1) It is an evaluation and synthesis of the available scientific literature. It is not intended to generate and report results of new research;
- 2) It does not evaluate or make any recommendation on whether any subspecies that is found to be valid should be used as a management unit, as the object of management action, or preferred to an alternative legal classification for protection, such as a distinct vertebrate population segment recognized under the U.S. Endangered Species Act (ESA 1973, as amended; USFWS and NOAA 1995). Suitability of a subspecies as a unit for any of these purposes requires further, separate analysis weighing legal and policy considerations;
- 3) It is not a review of the conservation status of any of the taxa considered; as such, it does not review threats to, or the population status of, any entity; and
- 4) It represents the views of the authors and not necessarily those of the U.S. Fish and Wildlife Service.

Approach taken in this review

Limitations of the available data. Several factors that concern the available scientific information bearing on wolf relationships complicate the assessment of taxonomic relationships. Wolves have been extirpated over large portions of North America, particularly most of the conterminous United States (Figure 1), so there are large gaps in geographic coverage, particularly for genetic data. Recent studies (discussed in later sections of this review) of DNA markers from museum specimens have attempted to address these gaps, but as yet they represent relatively few individuals.

For evaluating continent-wide patterns of variation and their potential taxonomic implications, it would be ideal to have comprehensive sampling across the landscape. This would allow for more rigorous testing and formulation of evolutionary scenarios, and for application of increasingly sophisticated methods of landscape genetics. Regrettably, sampling of wolf populations is far from even over North America. Sampling patterns can influence the interpretation of the genetic structure of populations and lead to erroneous conclusions (Schwartz and McKelvey 2009). Sampling may be relatively

Table 1. Available names for North American “gray” wolves in order of their publication date (does not include coyotes). Based on Goldman (1944), Hall and Kelson (1959), and Hall (1981).

Species or subspecies	Author	Date	Described as	
			Species	Subspecies
<i>Canis lycaon</i>	Schreber	1775	X	—
<i>Canis nubilus</i>	Say	1823	X	—
<i>Canis lupus occidentalis</i>	Richardson	1829	—	X
<i>Canis lupus fuscus</i>	Richardson	1839	—	X
<i>Canis lupus canadensis</i>	Blainville	1843	—	X
<i>Lupus gigas</i>	Townsend	1850	X	—
<i>Canis lupus var. rufus</i>	Audubon and Bachman	1851	—	X
<i>Canis occidentalis griseoalbus</i>	Baird	1858	—	X
<i>Canis pambasileus</i>	Elliot	1905	X	—
<i>Canis floridanus</i>	Miller	1912	X	—
<i>Canis tundraurum</i>	Miller	1912	X	—
<i>Canis nubilus baileyi</i>	Nelson and Goldman	1929	—	X
<i>Canis occidentalis crassodon</i>	Hall	1932	—	X
<i>Canis lupus arctos</i>	Pocock	1935	—	X
<i>Canis lupus orion</i>	Pocock	1935	—	X
<i>Canis rufus gregoryi</i>	Goldman	1937	—	X
<i>Canis lupus beothucus</i>	Allen and Barbour	1937	—	X
<i>Canis lupus labradorius</i>	Goldman	1937	—	X
<i>Canis lupus ligoni</i>	Goldman	1937	—	X
<i>Canis lupus youngi</i>	Goldman	1937	—	X
<i>Canis lupus irremotus</i>	Goldman	1937	—	X
<i>Canis lupus monstrabilis</i>	Goldman	1937	—	X
<i>Canis lupus mogollonensis</i>	Goldman	1937	—	X
<i>Canis tundraurum ungavensis</i>	Comeau	1940	—	X
<i>Canis lupus alces</i>	Goldman	1941	—	X
<i>Canis lupus columbianus</i>	Goldman	1941	—	X
<i>Canis lupus hudsonicus</i>	Goldman	1941	—	X
<i>Canis lupus bernardi</i>	Anderson	1943	—	X
<i>Canis lupus mackenzii</i>	Anderson	1943	—	X
<i>Canis lupus manningi</i>	Anderson	1943	—	X
<i>Canis lupus knightii</i>	Anderson	1947	—	X

intensive in areas that still have large wolf populations, such as Alaska and northern Canada, but information on other areas may be limited to a few, widely spaced individuals. Some published studies (e.g., Koblmüller et al. 2009a) report results from large data sets, but without sufficiently explicit geographic information to permit the reader to evaluate genetic population structure and interactions among populations.

Comparable sets of data are not available for many areas of taxonomic interest. For example, some areas may have detailed data on autosomal microsatellite variation, but lack information about lineage markers (mitochondrial DNA and Y-

chromosome haplotypes). In addition, very few of the reviewed studies were designed to address taxonomic questions. Taxon boundaries for certain subspecies that occur within the area covered by a particular study are often not recognized or addressed. Studies designed for other purposes, therefore, may not be informative on specific taxonomic issues and the evaluation of putative taxa.

There are also methodological problems associated with applying certain genetic analyses to taxonomic questions. A particularly notable example is the analysis of single-nucleotide polymorphisms (SNPs), which promises a “whole genome” characterization of populations. For example, the 48,000



Figure 1. Ranges of gray wolves in the conterminous United States: (a) historical range; (b) range at time of listing under the U.S. Endangered Species Act (ESA 1973); (c) current range in the Great Lakes states and experimental population areas in the northern Rocky Mountains and for the Mexican wolf *Canis lupus baileyi* in the Southwest. Credit: U.S. Fish and Wildlife Service.

SNPs included on the high-density-array Affymetrix V2 Canine GeneChip used in vonHoldt et al. (2011) were chosen from known genes or potentially expressed sequences adjacent to genes and are subject to nonneutral evolutionary forces (Boyko et al. 2010). The patterns of genetic diversity exhibited by wild canids and the degree to which these patterns differentiate the taxonomic groups that are the object of this review are the result of neutral evolution (e.g., mutation, genetic drift, gene flow, and population structure). Wild populations can develop different patterns of allele frequencies

resulting from adaptation under different selection pressures and these can affect measures of genetic differentiation such as F_{ST} (Helyar et al. 2011). Consequently, the conclusion in vonHoldt et al. (2011) that the population differentiation observed in the canine SNP array data set was the result of geographic variation in ecological conditions rather than the result of taxonomic distinctions was not unexpected.

Delimitation of species. There is no single species concept or set of criteria accepted by all taxonomists. Determination of reproductive relationships

and phylogenetic relationships represent two major approaches to defining species. Briefly, the biological species concept is based on reproductive relationships among populations. The ability to interbreed and realize gene flow between two populations is the indication that they belong to the same species Mayr (1963, 1970). Under phylogenetic species concepts, species are identified by their genealogical or phylogenetic relationships and diagnosability. The many variations of these concepts and others are reviewed by Wiley (1981), Avise (2004), and Coyne and Orr (2004). Avise and Ball (1990) and Avise (2004) proposed an integration of concepts from the biological species concept and phylogenetic species concepts into “concordance principles.” Their approach accepts intrinsic reproductive barriers as basic to species recognition, but incorporates “evidence of concordant phylogenetic partitions at multiple independent genetic attributes” (Avise 2004, p. 323).

Some recent taxonomists (e.g., Sites and Marshall 2004; de Queiroz 2007) have distinguished between species concepts and the operational criteria for empirical determination of species limits, or delimitation of species. A “separately evolving metapopulation lineage” has been suggested by de Queiroz (2007, p. 879) as a feature common to all species concepts, with the criteria from various concepts serving as operational criteria for assessing lineage separation. Operational criteria for species delimitation include fixation of character states, correlated divergence between morphology and genetics or between different genetic marker systems, gene flow, character divergence, monophyly, diagnosability, ecological divergence, and behavioral differences. Different operational criteria can lead to different conclusions because their necessary properties for species diagnosis develop at different times during the process of lineage divergence and speciation (de Queiroz 2007). Sites and Marshall (2004) and de Queiroz (2007) advocate an integrative approach that uses the appropriate operational criteria for all available classes of scientific information.

An integrative approach to species delimitation described above, and one that encompasses the concordance principles of Avise and Ball (1990), will be employed here for evaluation and delimitation of species of North American *Canis*. This is an eclectic approach that seeks to identify species as separate lineages supported by concordant data from various classes of genetic markers, morphometric analysis, behavior, and ecology. This approach is appropriate for North American *Canis* because populations of the putative species are, or have been, in contact with one another and there is considerable genetic information bearing on reproductive relationships. At the same time, there are extensive data from genetic lineage markers (mitochondrial DNA and Y-chromosome haplotypes) that provide phylogenetic

information that needs to be considered to understand the evolutionary history, ancestral condition, and taxonomic relationships of North American wolf populations. Lineage markers are essential for inferring possible precontact population differences that became complicated by contact and admixture between formerly separate populations or lineages (Cathey et al. 1998; Hanotte et al. 2000; Feng et al. 2001; Pidancier et al. 2006).

Various classes of relevant data (morphometrics, various genetic marker systems, ecological and behavioral attributes) each have somewhat different applications in assessing lineage separation and species delimitation. The taxonomy of North American *Canis* up to and including Goldman's 1944 monograph was based on morphological characters based on single specimens or means and ranges of character measurements of series of specimens, most commonly skulls. More recently, morphometric studies using multivariate statistical analysis have been applied to characterize variation within and among species (e.g., Jolicœur 1959; Lawrence and Bossert 1967; Kolenosky and Stanfield 1975; Skeel and Carbyn 1977). In only a few cases (e.g., Nowak 1979) have samples been sufficient to assess potential interspecies differences. Studies of autosomal microsatellite variation are useful for evaluating ongoing or recent gene flow (Avise 2004), at least among populations in recent contact or close proximity (Paetkau et al. 1997). Genetic distance measures and the presence and frequency of private alleles provide information on the amount and time of population divergence. Mitochondrial DNA (mtDNA) haplotypes provide information on older patterns of population divergence of maternal lineages (Avise 2004), owing to the lack of recombination. Maternal inheritance of mtDNA sequence limits some interpretations of population divergence, and recent studies that include Y-chromosome analyses (a paternal lineage marker) interpreted along with mtDNA can provide broader insight into population histories and ongoing population interactions. Unique haplotypes, like private alleles at nuclear loci, can indicate a history of population separation. With both lineage markers and nuclear loci, genetic divergence signals divergence time and potential species differences. Studies of variation in genes that encode variation under selection, such as black pelage color (Anderson et al. 2009), are of great interest for their adaptive value, but their inheritance as a single locus or group of closely linked loci limit their value for taxonomic determinations in comparison to multiple, unlinked, highly variable and neutral autosomal markers combined with mitochondrial and Y-chromosome lineage markers. In a few cases, ecological and behavioral variation among *Canis* populations has been invoked to explain genetic evolutionary

differences. Where ecological and behavior data are available, they are here interpreted for their relevance to the evolutionary history and taxonomic standing of populations. To form a basis for the analysis of species and subspecies, summaries of taxonomically relevant information from studies in the literature were prepared and are presented in the Appendix at the end of this paper.

As discussed later in this review, North American *Canis* comprises two major lineages or clades: one including most gray wolves, and the other including eastern wolf *Canis lupus lycaon*, red wolf, and coyote. The species-level taxonomic implications of these two clades are first evaluated. With respect to *C. lupus*, the most controversial question about its species limits raised subsequent to Goldman's (1937, 1944) consolidation of various North American species names under *C. lupus* is the proposal that the eastern wolf is a separate species and outside the species limits of *C. lupus*. Reproductive relationships of populations representing the eastern wolf and other *C. lupus*, in the narrow sense, can be assessed because there has been interbreeding and admixture, and data are available from genetic markers suitable for evaluating the extent of admixture and alternative interpretations of the origin of coyote clade markers within the eastern wolf. Whether the red wolf is within the species limits of *C. lupus* is less controversial.

There has been, at least, historical contact, and informative genetic data are available; therefore, a similar approach can be taken in evaluating species limits within the coyote clade, with one exception. Extirpation, limited geographic sources for genetic data, and uncertainties about historical distributions do not permit a meaningful assessment of reproductive relationships between eastern wolf and red wolf. For determination of species-level relationships between these two putative taxa, they must essentially be treated as allopatric populations, and operational criteria other than reproductive relationships must be applied. Some data are available for assessing nonreproductive criteria, such as correlated divergence between morphology and genetics, different genetic marker systems, character divergence, cohesion, monophyly, and diagnosability.

Consideration of admixture in delimiting species. Assessment of gene flow and reproductive barriers does not require absolute reproductive isolation for recognition of species limits and boundaries, and examples of interspecific hybridization, including species of *Canis*, are not new (Mayr 1942). Partially because of the power of new systems of molecular genetic markers, incomplete reproductive isolation between recognized species is now known to be common, especially in certain groups (Grant and Grant 1992; Schwenk et al. 2008), and examples include familiar species, such as some species pairs of Darwin's finches

(Grant and Grant 2006), mallards *Anas platyrhynchos* and American black duck *Anas rubripes* (Mank et al. 2004), and Canadian lynx *Lynx canadensis* and bobcat *Lynx rufus* (Schwartz et al. 2004). The cohesion species concept, which has similarities to the biological species concept, was proposed by Templeton (1989) to at least partly deal with situations, such as those in canids, where there is naturally occurring hybridization among species and reproductive isolation is difficult to evaluate. Cohesion mechanisms include promoting genetic identity with gene flow and constraints from selective forces. If absolute isolation were required for species recognition, all North American *Canis* (wolves and coyotes) would be considered one species, because all component taxa are linked by evidence of interbreeding, although the incidence of such effective introgression can range from ancient and very rare in some cases to modern and ongoing in others. This interpretation would also mean that coyotes and wolves in western North America are the same species, despite marked differences in morphology, ecology, behavior, and genetic composition. Such a single-species classification would obscure evolutionarily important diversity. The existence of genetic admixture is acknowledged in instances evaluated in this review. In evaluating the significance of such admixture to species limits, it is the reproductive fate of hybrid individuals that is important in determining whether introgression is occurring to the extent that the formerly separate gene pools and species are merging or persisting (Coyne and Orr 2004).

Delimiting subspecies of Canis lupus. There is no scientific consensus on what constitutes a subspecies, and some authorities (e.g., Wilson and Brown 1953; Zink 2004) have questioned the utility of subspecies. Mayr (1963, glossary) defined subspecies as: "An aggregate of local populations of a species inhabiting a geographic subdivision of the range of the species, and differing taxonomically from other populations of the species." Mayr (1963, p. 348; 1969, p. 190) explains "differing taxonomically" with a "75-percent rule," whereby 75 percent of individuals of a valid subspecies differ in morphological characters from individuals of other subspecies or populations, which is equivalent to a 90% overlap in characters between subspecies. Patten and Unitt (2002, p. 27) define subspecies as: "diagnosable clusters of populations of biological species occupying distinct geographic ranges." They do not require that diagnosability be absolute, but advocate 90% separation as a more stringent criterion than the "75-percent rule."

The most stringent criterion that has been proposed for subspecies recognition is reciprocal monophyly (Zink 2004). A number of objections to monophyly as a subspecies criterion have been raised; perhaps foremost is that in phylogenetic classifications it is a species-level criterion and

inappropriate for application below the species level (Goldstein et al. 2000; Patten and Unitt 2002). Its application using genetic data is limited to genetic sequences that do not recombine, such as mitochondrial DNA, and therefore application usually depends on one type of marker rather than on multiple markers that can be tested for concordance, as in the Avise (2004) criterion.

Avise (2004, p. 362) attempted to incorporate phylogenetic information within a biological species concept in providing the following guidance on recognizing subspecies:

Within such units [=species], “subspecies” warranting formal recognition could then be conceptualized as groups of actually or potentially interbreeding populations (normally mostly allopatric) that are genealogically highly distinctive from, but reproductively compatible with, other such groups. Importantly, the empirical evidence for genealogical distinction must come, in principle, from concordant genetic partitions across multiple, independent, genetically based molecular (or phenotypic; Wilson and Brown 1953) traits.

A common feature of all of the above definitions is that they recognize that subspecies are groups of populations, and most recognize that subspecies can be variable and overlap in distinguishing characters, to some degree.

The general concordance approach of Avise (2004) is employed in this review for recognizing subspecies of gray wolf. The nature of the available data does not permit the application of many of the subspecies criteria reviewed above. For example, the “75-percent rule” is for individual character analysis, but most available analyses of morphological data for wolves use multivariate statistics that summarize variation in many characters. Furthermore, the available data on a particular taxonomic question comprise a variety of very different types of information that must be integrated. The approach to subspecies of Avise (2004), described above, is the most applicable to the disparate data sets available on wolves. Concordance in patterns from measures of divergence from morphology and various genetic marker systems is taken as support for recognition of a subspecies.

Morphological information from different studies varies greatly in methodology and geographic coverage. In attempting to integrate currently available morphological information with genetic information, one is faced with two alternative classifications based on morphology: 1) the 24 subspecies recognized by Hall and Kelson (1959) and Hall (1981), which was largely based on the

character analysis and expert, but subjective, judgments of Goldman (1937, 1944; Figure 2 of this paper); or 2) the classification of Nowak (1995, 2002; Figure 3 of this paper), based on multivariate statistical analyses. Both classifications can be criticized on the basis of coverage and underlying methodology. Wolves in many of the areas occupied by the subspecies in the Goldman–Hall classification have been extirpated, especially in the lower 48 United States, so several putative subspecies in those areas must be considered extinct. Although nearly all the same subspecies are recognized in various versions of this classification, the subspecies boundaries vary to some extent. Lastly, there is very little information for some of these named subspecies, especially from genetic studies, at least partially because few studies of genetic variation address the potential subspecific identity of the subject populations.

Nowak (1995) reduced the number of recognized subspecies to five; the subspecies and their geographic ranges recognized by Nowak (1995, 2002; presented in Figure 3 of this paper) are more tractable for comparison to available genetic data, but key information is still lacking, and there are methodological concerns that require mention. Nowak (1995, p. 394) discussed the standards he used in revising the subspecies of *C. lupus*: “Substantive statistical breaks in such trends, as discussed above, were taken as evidence of taxonomic division.” Nowak’s classification is based primarily on discriminant function analysis, which requires that groups be known or distinguished a priori by other data, and is most useful for evaluating the affinity of unknown individuals (e.g., Maldonado et al. 2004), and for identifying characters most useful for distinguishing among groups (James and McCulloch 1990). Its use in determining intergroup differences has been criticized because the a priori identification of groups is sometimes based on the same data that are used to generate the distance measures, which introduces circularity into the analysis, and differences that can readily discriminate between groups may be relatively small and of little biological significance (James and McCulloch 1990; Lance et al. 2000). For measuring intergroup differences for taxonomic analysis, there are more objective methods, such as principal components analysis (PCA); an example is discussed later in the analysis of the standing of the Mexican wolf, *C. l. baileyi*.

Given the drawbacks of both the Goldman–Hall and Nowak classifications, we attempted to consider both in our analysis of the available data. The initial approach of this analysis, following concordance principles of Avise (2004), was to evaluate concordance between distributions of morphological and genetic variation for the five subspecies of gray wolf *C. lupus* identified in the Nowak (1995, 2002)

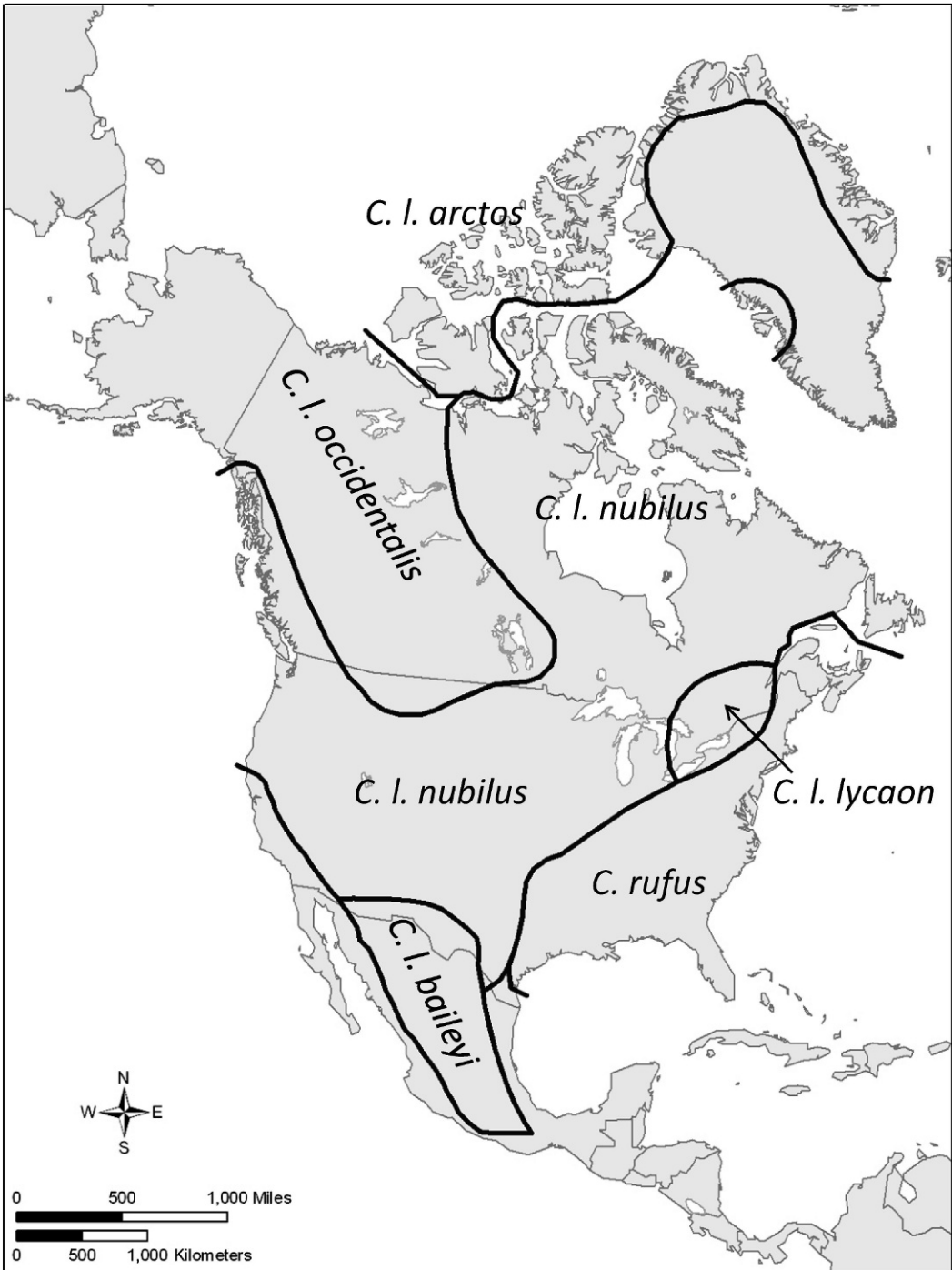

Figure 14. Distribution of subspecies of *Canis lupus*

- | | |
|---------------------------------|--------------------------------|
| 1. <i>Canis lupus tundrarum</i> | 13. <i>C. l. columbianus</i> |
| 2. <i>C. l. pambasileus</i> | 14. <i>C. l. ligoni</i> |
| 3. <i>C. l. alces</i> | 15. <i>C. l. fuscus</i> |
| 4. <i>C. l. occidentalis</i> | 16. <i>C. l. crassodon</i> |
| 5. <i>C. l. hudsonicus</i> | 17. <i>C. l. youngi</i> |
| 6. <i>C. l. arctos</i> | 18. <i>C. l. mogollonensis</i> |
| 7. <i>C. l. orion</i> | 19. <i>C. l. monstrabilis</i> |
| 8. <i>C. l. labradorius</i> | 20. <i>C. l. baileyi</i> |
| 9. <i>C. l. beothucus</i> | 21. <i>C. l. bernardi</i> |
| 10. <i>C. l. lycaon</i> | 22. <i>C. l. meekenzii</i> |
| 11. <i>C. l. nubilus</i> | 23. <i>C. l. manningi</i> |
| 12. <i>C. l. irremotus</i> | |

Figure 2. Subspecies of *Canis lupus* recognized by Goldman (figure 14 of Goldman 1944 in *The Wolves of North America*, S. P. Young and E. A. Everman, editors, ©Wildlife Management Institute; reproduced with permission).

Downloaded from <http://meridian.allenpress.com/doi/pdf/10.3996/nafa.77.0001> by India user on 16 August 2022



Downloaded from <http://meridian.allenpress.com/doi/pdf/10.3996/nafa.77.0001> by India user on 16 August 2022

Figure 3. Ranges of North American *Canis lupus* subspecies recognize by Nowak (1995, 2002) and of *C. rufus* (after Nowak 2002).

classification. Despite the reservations, expressed above, that discriminant function analysis can result in oversplit classifications, Nowak actually reduced the number of subspecies and greatly consolidated

the subspecific classification of *C. lupus*. The scientific support for the validity of these five subspecies is evaluated using the relevant information from the study summaries available in the Appendix. A

subspecies is found to be supported when the geographic distribution of specific genetic markers coincides with its general distribution based on morphological analyses. The distribution of mitochondrial DNA and Y-chromosome haplotypes associated with different clades, and presumed Old World sources, is of particular interest. Concordance between morphometric and genetic data is therefore taken as evidence for the validity of a subspecies. This approach should not be interpreted as a priori acceptance of Nowak's (1995) subspecies classification. Based on additional information, primarily genetic data, this review comes to conclusions that differ from Nowak (1995) on some taxonomic interpretations. When genetic data are available on a scale to evaluate the distinctiveness of subspecies in the Goldman–Hall classification that Nowak (1995) reduced to synonymy, the validity of those subspecies is considered.

Biology of the Species

This section first provides summaries of the taxonomic history of *Canis* and some aspects of ecology and behavior that have been identified as important in explaining population structure. Summaries of the taxonomically relevant information in publications on morphology and genetics are provided in the Appendix.

Taxonomic background on wolf species and subspecies

History and overview of the genus Canis. This brief summary of the global history of *Canis* is based primarily on the reviews by Nowak (1979) and Kurtén and Anderson (1980). The genus *Canis* originated in North America by the middle Pliocene. Members of the genus probably began colonizing the Old World soon (in geological time) thereafter, where their descendants include the modern species *Canis adustus* (side-striped jackal; range: Africa), *Canis aureus* (golden jackal; Eurasia and North Africa), *Canis mesomelas* (black-backed jackal; Africa), and *Canis simensis* (Ethiopian wolf; Ethiopia [Wilson and Reeder 2005]). Diverse lineages and species of *Canis*, including coyote, evolved in North America during the Pliocene and Pleistocene. Members of one of these North American lineages entered Eurasia in the early Pleistocene and eventually evolved into the gray wolf, *C. lupus*. Gray wolf later entered North America, where its fossils first appear in middle Pleistocene deposits. More than one invasion of North America by Eurasian *C. lupus* has been suggested based on morphological data and biogeographical reconstruction (Nowak 1983, 1995). This has been confirmed by genetic data that support at least three separate invasions from

different Eurasian lineages to explain the patterns of genetic variation observed in modern *C. lupus* of North America (Vilà et al. 1999). An additional gray wolf lineage known only from Pleistocene individuals preserved in permafrost in Alaska became extinct without leaving modern descendants (Leonard et al. 2007).

Gray wolf is the only species of *Canis* with a range that includes portions of both Eurasia and North America. Gray wolves had very large historical distributions in both areas: throughout all of Eurasia except Southeast Asia, and in North America from the Arctic to Mexico. In addition to the five North American subspecies, Nowak (1995) recognized five subspecies of *C. lupus* in Eurasia, and stated that there was insufficient material to statistically evaluate four other Eurasian subspecies. None of the modern recognized subspecies occurs or occurred in both Eurasia and North America (Nowak 1995).

Canis in North America. The first published name of a taxon of *Canis* from North America is *Canis lycaon*, which was published in 1775 based on the earlier description and illustration of an individual that was thought to have been captured near Quebec (Goldman 1937). The next North American taxon names were published when Say (1823) named and described *Canis nubilus* based on wolves he observed in eastern Nebraska. The coyote, *Canis latrans*, was also described by Say (1823) from the same Nebraska locality at the same time, and his observations appear to be the first that clearly distinguish between wolves and coyotes. These and the other 28 available scientific names subsequently described from North American wolf taxa are listed in chronological order in Table 1. Wolf taxa were originally described as either subspecies (sometimes indicated as a trinomial “variety”) or species through 1912. Thereafter, all new taxa were described as subspecies. Most available wolf names were subspecies described in the 1930s and 1940s.

Earlier names were published as individual descriptions in various publications, including reports of exploratory expeditions. The first attempts to compile consolidated treatments of North American wolf taxa were the incomplete reviews by Miller (1912) and Pocock (1935). Goldman (1937, 1944) provided the first truly comprehensive treatment of North American wolf taxa, but did not include coyote. Goldman's classification addressed uncertainties in the nomenclatural history of the taxa, and included many subspecies, many of which he himself described. A particularly notable feature of Goldman's classification was recognition of two species of wolves in North America: red wolf (as *Canis niger*, now known as *C. rufus*) occupying parts of the southeastern United States, and gray wolf occupying the remaining range of wolves in North America.

Table 2. Subspecies of *Canis rufus* (Goldman 1944; Nowak 1979; Hall 1981) and of *Canis lupus* (Hall and Kelson [1959] and Hall [1981], largely based on Goldman [1944]). The five subspecies of *Canis lupus* recognized by Nowak (1995) are in bold, and each is followed by its synonyms as recognized in that reclassification.

Subspecies	Author(s)	Date	Range (R) from Nowak (2002) or type locality (TL)
<i>Canis rufus rufus</i>	Audubon and Bachman	1851	R: Central and Gulf coast Texas & Louisiana
<i>Canis rufus floridanus</i>	Miller	1912	R: United States east of the Mississippi River
<i>Canis rufus gregoryi</i>	Goldman	1937	R: Northeast Texas to Indiana
<i>Canis lupus lycaon</i>	Schreber	1775	TL: Restricted by Goldman (1937) to vicinity of Quebec, Quebec
<i>Canis lupus baileyi</i>	Nelson and Goldman	1929	TL: Colonia Garcia (about 60 miles SW of Casas Grandes), Chihuahua, Mexico (altitude 6,700 feet)
<i>Canis lupus nubilus</i>	Say	1823	TL: Near Blair, Washington County, Nebraska
<i>Canis lupus fuscus</i>	Richardson	1839	TL: Banks of Columbia River below The Dalles, Oregon
<i>Canis lupus crassodon</i>	Hall	1932	TL: Tahsis Canal, Nootka Sound, Vancouver Island, British Columbia
<i>Canis lupus beothucus</i>	Allen and Barbour	1937	TL: Newfoundland
<i>Canis lupus labradorius</i>	Goldman	1937	TL: Fort Chimo, Quebec
<i>Canis lupus ligoni</i>	Goldman	1937	TL: Head of Duncan Canal, Kupreanof Island, Alexander Archipelago, Alaska
<i>Canis lupus youngi</i>	Goldman	1937	TL: Harts Draw, N slope of Blue Mountains, 20 miles NE Monticello, San Juan County, Utah
<i>Canis lupus irremotus</i>	Goldman	1937	TL: Red Lodge, Carbon County, Montana
<i>Canis lupus monstrabilis</i> ^a	Goldman	1937	TL: 10 miles S of Rankin, Upton County, Texas
<i>Canis lupus mogollonensis</i> ^a	Goldman	1937	TL: S. A. Creek, 10 miles NW Luna, Catron County, New Mexico
<i>Canis lupus hudsonicus</i>	Goldman	1941	TL: Head of Schultz Lake, Keewatin, [now Nunavut], Canada
<i>Canis lupus manningi</i>	Anderson	1943	TL: Hantzsch River, E side Foxe Basin, W side Baffin Island, District of Franklin, Northwest Territories [now Nunavut], Canada
<i>Canis lupus arctos</i>	Pocock	1935	TL: Melville Island, Canadian Arctic
<i>Canis lupus orion</i>	Pocock	1935	TL: Cape York, northwestern Greenland
<i>Canis lupus bernardi</i>	Anderson	1943	TL: Cape Kellett, Banks Island, Northwest Territories, Canada
<i>Canis lupus occidentalis</i>	Richardson	1829	TL: Restricted by Miller (1912) to Fort Simpson, Mackenzie, Canada
<i>Canis lupus griseoalbus</i>	Baird	1858	TL: Restricted by Hall and Kelson (1952) to Cumberland House, Saskatchewan
<i>Canis lupus pambasileus</i>	Elliot	1905	TL: Upper waters of Sushitna River, Region of Mount McKinley
<i>Canis lupus tundrarum</i>	Miller	1912	TL: Point Barrow, Alaska
<i>Canis lupus alces</i>	Goldman	1941	TL: Kachemak Bay, Kenai Peninsula, Alaska
<i>Canis lupus columbianus</i>	Goldman	1941	TL: Wistaria, N side of Ootsa Lake, Coastal District, British Columbia
<i>Canis lupus mackenzii</i>	Anderson	1943	TL: Imnanuit, W of Kater Point, Bathurst Inlet, District of Mackenzie, Northwest Territories

^a Considered synonyms of *Canis lupus baileyi* Goldman (1937) by Bogan and Mehlhop (1983).

For decades, the subspecies classification of gray wolves was the 24 subspecies recognized by Hall and Kelson (1959) and Hall (1981), which was based primarily on Goldman's (1944) classification. The range map of subspecies from Goldman (1944, figure 14) is reproduced here as Figure 2. Nowak's morphometric studies led him to propose the reduction in number of the North American subspecies of gray wolf from the 24 previously recognized to 5 (Table 2; Figure 3). Brewster and Fritts (1995) summarized controversies concerning North American wolves, with a concentration on western North America, based on the genetic and morphometric information available at that time. The following sections provide more detailed taxonomic background on individual North American wolf taxa.

Red wolf. *C. rufus* has usually been recognized as a species separate from gray wolf (Goldman 1937, 1944; Nowak 1979; Hall 1981; Baker et al. 2003), but is sometimes considered a subspecies of gray wolf (Lawrence and Bossert 1967; Wilson and Reeder 2005). Nowak (1979, p. 85) has noted that the name *C. niger* (Bartram 1791), which was used by Goldman (1944) and some other authors for this species, was determined by the International Commission on Zoological Nomenclature to be unavailable for nomenclatural purposes. The three subspecies of red wolf recognized by Goldman (1937, 1944) and Hall (1981) are listed in Table 2 along with their general historical ranges. The red wolf survives only in captive-breeding facilities and reintroduced populations in North Carolina (Phillips et al. 2003). All surviving individuals are descendants of red wolves captured within the historical range of the subspecies *C. r. rufus*, so that nearly all genetic data on *C. rufus* are derived from individuals attributable to that subspecies. Because all living red wolves are derived from this single subspecies, the subspecies classification will not be treated in this review.

Gray wolf subspecies. The more complex subspecies classification of Goldman (1944), Hall and Kelson (1959), and Hall (1981), as well as the simplified classification of Nowak (1995), are presented in Table 2. The recognized names in this table will be used in the following discussion of their taxonomic treatment.

The taxonomic status of the eastern wolf is controversial. It has been considered a full species, *C. lycaon* (Wilson et al. 2000; Baker et al. 2003); a subspecies of gray wolf, *C. lupus lycaon* (Goldman 1937, 1944; Nowak 1995, 2002, 2003); the result of coyote introgression into gray wolf (Lehman et al. 1991); the same species as the red wolf (Wilson et al. 2000); or a result of hybridization between red wolf and gray wolf (Nowak 2002, 2003, 2009). Goldman (1937, 1944) considered the eastern wolf to be a subspecies, *C. l. lycaon*, found from southern Quebec

and Ontario to Minnesota. He also described *Canis lupus labradorius* from northern Quebec, stating that it was similar to eastern wolf, but larger. Goldman (1944) mapped a geographic range for eastern wolf that extended from northeast Florida to eastern Minnesota and states to the east, and Ontario and southern Quebec in Canada (Nowak [2002] now places the Florida location at "vicinity of Miami"). He recognized the following three neighboring subspecies: 1) *Canis lupus nubilus* (plains wolf): bordering eastern wolf on the west from southern Illinois to Manitoba. Goldman (1944, p. 444) notes, however, "[s]pecimens from eastern Minnesota and Michigan seem more properly referable to *lycaon*, but relationship to *nubilus* is shown in somewhat intermediate character"; 2) *Canis lupus hudsonicus* (Hudson Bay wolf): bordering eastern wolf range west of Hudson Bay in northern Manitoba; 3) *C. l. labradorius* (Labrador wolf): bordering eastern wolf range in northern Quebec.

The general ranges of these three subspecies were followed by Hall and Kelson (1959) and Hall (1981). Wilson et al. (2000) proposed that eastern wolf be restored to full species status based on its genetic distinctness from gray wolf. They also proposed that it is the same species as red wolf, and that this combined taxon be recognized under the earlier published name, *C. lycaon*.

The Mexican wolf was described by Nelson and Goldman (1929) as *Canis nubilus baileyi*, with a type locality identified in Chihuahua, Mexico. Its distribution was described as: "Southern and western Arizona, southern New Mexico, and the Sierra Madre and adjoining tableland of Mexico as far south, at least, as southern Durango." The specimens examined included a wolf from Kendrick Peak on the Coconino Plateau in north-central Arizona and several individuals from the Sacramento Mountains, New Mexico. Goldman (1937) reclassified Mexican wolf as a subspecies of the species *C. lupus*, so that its name became *C. l. baileyi*. He also included the Kendrick Peak, Arizona, specimen with his newly described *Canis lupus mogollonensis* (Goldman 1937, 1944), which shifted the northern limits of Mexican wolf further south in Arizona. Goldman (1937) mapped the eastern boundary of Mexican wolf as contiguous with the western boundary of *Canis lupus monstrabilis* in southeastern New Mexico, far western Texas, and eastern Mexico. This view of the boundary of Mexican wolf in Arizona was followed by Hall and Kelson (1959), Nowak (1979), and Hall (1981). Based on their morphometric analysis of wolves of the southwestern United States and adjacent Mexico, Bogan and Mehlichop (1983) referred wolves formerly assigned to *C. l. mogollonensis* and *C. l. monstrabilis* to Mexican wolf. Nowak (1995) included Mexican wolf as one of five North American

subspecies that he recognized in his revision of gray wolf subspecies, but contrary to Bogan and Mehlhop (1983), referred *C. l. mogollonensis* and *C. l. monstabilis* to *C. l. nubilus*.

Arctic wolf, *Canis lupus arctos*, was described from skulls from Melville Island and Ellesmere Island in the Canadian Arctic (Pocock 1935). *C. l. arctos* was subsequently recognized by Goldman (1944), Hall and Kelson (1959), and Hall (1981). Based on morphometric analysis, Nowak (1995) placed *Canis lupus orion* and *Canis lupus bernardi* as synonyms of *C. l. arctos*. Both were recognized as separate subspecies by Goldman (1944), Hall and Kelson (1959), and Hall (1981). The range of Nowak's expanded *C. l. arctos* generally includes Greenland and all the Canadian Arctic Islands, except Baffin Island, which was included within the range of *C. l. nubilus*.

C. l. nubilus and *Canis lupus occidentalis* are the most geographically widespread of the five subspecies of gray wolf recognized by Nowak (1995), and share long and complex borders. They also have the largest synonymies of the five species, with 11 synonyms recognized for *C. l. nubilus* and 6 for *C. l. occidentalis* (Table 2).

Ecology, behavior, prey, and habitat

The following information is offered to provide some very brief background on these subjects. More detailed and comprehensive treatments are provided by Mech (1974) and Mech and Boitani (2003).

Based on its extraordinarily large historical range, gray wolf has been one of the most successful large, terrestrial, vertebrate species to occupy the earth. In North America, wolves can be successful in all terrestrial habitat types (Carroll 2003; Carroll et al. 2003, 2006; Oakleaf et al. 2006), except the most extreme deserts. Differences in habitat have been correlated with variations in behavior, including migration and prey selection. For example, Kolonosky and Stanfield (1975) have described variation in Ontario wolves, where larger wolves of boreal forests specialize on moose *Alces americanus* and caribou *Rangifer tarandus* as prey, while smaller wolves in deciduous forest habitats specialize on white-tailed deer *Odocoileus virginianus*. Carmichael et al. (2001) and Musiani et al. (2007) have proposed that differences in migratory behavior and prey have influenced genetic differences between wolves that follow migratory caribou on the tundra and wolves that prey on more sedentary caribou in forested areas. These studies are further discussed in the following sections on morphology and genetics. North American wolves specialize on large mammals as prey. In addition to caribou, moose, and deer, they feed on muskox *Ovibos moschatus*, American bison *Bison bison*, elk *Cervus elaphus*, mountain sheep *Ovis* sp., and mountain goat *Oreamnos americanus*. They also consume domestic ungulates: cattle,

sheep, and goats. Mech (1974) indicated that American beaver *Castor canadensis* are the smallest prey to be consistently reported for wolves. Lagomorphs and smaller rodents are consumed opportunistically.

Pack structure has been alternatively explained by kin selection and benefits of sharing prey with offspring. Wolves are cursorial animals capable of traveling long distances (e.g., Mech 1987; Musiani et al. 2007). Wolves can range from one habitat type to another, and are capable swimmers (Mech 1974). Even where rivers are too wide for regular crossing, wolves can cross when sufficient ice forms (Carmichael et al. 2001). Mountains are generally not a barrier to wolf movement, and in some portions of their range, mountains are where wolves are most common. Particularly steep and high ranges have, however, been invoked to explain the partial isolation and genetic divergence of coastal wolves in southeastern Alaska and British Columbia from inland populations (Weckworth et al. 2005, 2010).

The factors briefly discussed above have been invoked as ad hoc explanations to explain certain patterns of morphological or genetic variation in wolves. Wolves are large, vagile animals that have few natural limitations in areas that they can colonize. There do not appear to be any general rules predicting where wolves will be found or where geographic variation can be expected. There can, however, be combinations of behavior, prey, and habitat that can contribute to the partial isolation of populations, and foster interpopulational differences. Instances will be identified in the following sections summarizing studies on morphology and genetics.

Taxonomic Evaluation and Discussion

Views vary on the number and identity of modern species of *Canis* in North America. There is general agreement only that coyote is a separate species, and that dogs are derived from *C. lupus* (Vilà et al. 1999). The following analysis and discussion will first address the number of species of wolf in North America. It will begin with probably the most contentious question of whether the eastern wolf is within the species limits of *C. lupus*. The taxonomic status of red wolf and eastern wolf with respect to each other and coyote will then be addressed. Last, the subspecies classification within *C. lupus* will be evaluated. The accounts of various taxa provided here are uneven in length, owing primarily to the amount and complexity of the information available for discussion. For example, the longest discussion is of gray wolf–eastern wolf relationships because of the amount and detail of the available data, the complexity of the biological questions involved, and divergent opinions on the history and taxonomic standing of the eastern wolf.

Species limits of *Canis lupus* relative to eastern wolf

The most contentious issue related to the species limits of *C. lupus* in North America is the placement of the eastern wolf, which has also been referred to as the Great Lakes wolf (Leonard and Wayne 2008): Is the eastern wolf within the species limits of *C. lupus* as either a subspecies, *C. l. lycaon* (Goldman 1937; Wilson and Reeder 2005) or a unique ecotype (Koblmüller et al. 2009a), or does it represent a different species, *C. lycaon*, outside the species limits of *C. lupus* (Wilson et al. 2000)? Consideration of the implications of admixture for determining potential interspecies barriers is an essential part of this analysis. This section assesses whether populations referred to as eastern wolves should be considered members of *C. lupus*.

The positions of various authors of taxonomic studies on the geographic range of the eastern wolf were briefly summarized earlier in the section on taxonomy. All extant wolves that might be assigned to the eastern wolf occur in the general area from southern Ontario and Quebec, west to Minnesota and Manitoba. Wolves in this range were nearly exterminated and, by the 1970s, the only known wolves that remained in the conterminous United States were in northeastern Minnesota (Figure 1 of this paper; Mech 1974). At about this time, wolves had also been eliminated from most of southern Ontario and Quebec (Mech 1974) and replaced by a population of coyotes that had been influenced by hybridization with wolves (Kolenosky and Standfield 1975; Rutledge et al. 2010b). Wolves have subsequently expanded their range in Minnesota and recolonized Wisconsin and the Upper Peninsula of Michigan.

Morphometrics. Trends of increasing size among wolves to the north and west of southern Ontario and Quebec have been noted in morphometric studies covering the Great Lakes region. The association of smaller wolves with white-tailed deer in deciduous forests and larger wolves with larger prey, such as moose and caribou, in boreal forests has been frequently cited (Kolenosky and Standfield 1975; Skeel and Carbyn 1977; Schmitz and Kolenosky 1985). When wolf skulls were divided by source habitat into deciduous forest (eastern wolf) and boreal forest (*C. lupus*), discriminant function analysis distinguished 75% of boreal wolves from eastern wolves, and boreal wolves were >25% larger in body mass (Kolenosky and Standfield 1975). This size difference cannot be entirely attributed to interbreeding of eastern wolves with coyotes because the “Tweed wolves” of southern Ontario, which have been influenced by recent coyote introgression, were excluded from these samples. Discriminant function analyses of additional skull and body measurements have confirmed the smaller

size of eastern wolves relative to gray wolves and distinguished them from coyotes and coyote–wolf hybrids (Schmitz and Kolenosky 1985). Moreover, gray-fawn coat color was most common in both samples, but black, cream, and white colors found in boreal wolves were rare in eastern wolves. Skeel and Carbyn’s (1977, figures 2, 3) PCA places eastern wolves intermediate between *C. l. nubilus* and *C. l. occidentalis* (following Nowak’s [1995] revision) on the first principal component axis, but are closer to *C. l. nubilus*. Their eastern wolf sample was from extreme southwestern Ontario in an area where influence by *C. l. nubilus* can be expected.

Nowak’s (1979, figure 7) discriminant function analysis of skull features found the individuals he attributed to *C. l. lycaon* (eastern wolf) to be generally smaller than northern and western *C. lupus*. Within this eastern wolf sample, the individuals from the western range that he recognized for *C. l. lycaon* (Michigan, Minnesota, Wisconsin, and western Ontario) had a greater range of variation, and several individuals were larger than wolves from southern Ontario and Quebec. Based on this and additional morphometric analyses (Nowak 1995, 2002, 2009), Nowak recognizes the eastern wolf as a subspecies of *C. lupus* and restricts its range to southern portions of Ontario and Quebec, while attributing Minnesota wolves to *C. l. nubilus*. His Minnesota samples, however, were taken after 1960 (Nowak 1995) or 1970 (Nowak 2002, 2009), during a period of likely increased movement into Minnesota of *C. l. nubilus* from the west and north (Mech and Frenzel 1971; Mech and Paul 2008; Mech 2010; Mech et al. 2011). Nowak’s data for Minnesota likely reflect this substantial and recent contribution of *C. l. nubilus* to Minnesota wolves. As will be discussed later, the genetic data (Fain et al. 2010; Wheelton et al. 2010) indicate a substantial genetic contribution from the eastern wolf throughout the western Great Lakes to Minnesota and western Ontario.

The utility of Nowak’s (1995) analysis is limited in determining whether the eastern wolf is distinct from *C. lupus* by his inclusion of recent wolves of probable *C. l. nubilus* origin in samples intended to represent the eastern wolf. The sample from Algonquin Provincial Park is the only eastern wolf sample in these studies that has not been greatly influenced by gray wolves. When Algonquin wolves are identified as such on discriminant function plots (Nowak 1995, figures 10, 11), most individuals appear outside the polygons representing *C. lupus*. Additional eastern wolves from southern Ontario and Quebec produced a similar result (Nowak 2002, figure 8; 2009, figure 15.2).

The eastern wolf is smaller than other wolves in the analysis, and geographical trends in size correspond to habitat differences and are consistent

with the proposal of Kolenosky and Stanfield (1975) of prey specialization of smaller wolves on white-tailed deer in deciduous forests. Morphometric data do not provide direct information on monophyly or reproductive relationships, but in this case, the geographic trends in body size are consistent with habitat distributions and ecological specialization. All morphometric studies find the eastern wolf to be an outlier to *C. lupus*, and where there is some overlap in morphometric space, the eastern wolf extends well beyond the limits of *C. lupus*.

Autosomal microsatellite DNA. The variably admixed nature of eastern wolf populations in the western Great Lake states determined from microsatellite DNA analysis has been noted by Fain et al. (2010) and Wheeldon et al. (2010). The conclusion of Koblmüller et al. (2009a) of little admixture in wolves of this region may have been influenced by the distant (Northwest Territories and Alberta) western gray wolf samples used for comparison. STRUCTURE analysis, as well as divergence measures such as F_{ST} , can be erroneously interpreted as indicating genetic discontinuities when there are significant gaps in sampling pattern (Pritchard et al. 2000; Schwartz and McKelvey 2009). Further, these western wolves likely represent *C. l. occidentalis* rather than *C. l. nubilus*; whereas, *C. l. nubilus* is the subspecies of gray wolf likely to be involved in admixture with the eastern wolf in the western Great Lakes.

There are indications in the STRUCTURE analysis presented by Koblmüller et al. (2009a, figure 3) that there is more genetic variation in the wolf sample from the Great Lakes region than is suggested by the outcome (figure 3c) using $K = 4$. The $L(K)$ values for $K = 4$ and $K = 5$ are indistinguishable in their figure 3a, and the range of variation for Great Lakes wolves in the factorial correspondence analysis (their figure 3d) is much larger than that of coyotes and western gray wolves. Elevated levels of genetic variation are consistent with an admixed population. Wheeldon et al. (2010) included samples from northwest Ontario that clearly portray admixture, and the higher allelic richness of western Great Lakes wolves (Fain et al. 2010) is also consistent with their genetically composite ancestry. Data from historical specimens from Minnesota and Wisconsin (Koblmüller et al. 2009a; Wheeldon and White 2009) also suggest that admixture of the eastern wolf and western *C. lupus* had taken place prior to their extirpation from the region.

Both the microsatellite and morphometric data indicate the same trend from Algonquin Provincial Park in the east with increasing influence by *C. lupus* to the west (Table 3). In the western Great Lakes, most wolves have indications of admixture (Fain et al. 2010; Wheeldon et al. 2010), but individual wolves vary greatly in the proportion of eastern wolf

influence in their autosomal microsatellite genotypes. In other words, the microsatellite DNA data indicate that the wolves of the western Great Lakes region do not comprise a homogenous population, which is consistent with a composite origin and incomplete admixture. The microsatellite data also distinguish eastern wolves from western *C. lupus* in neighboring trees (Roy et al. 1994; García-Moreno et al. 1996; Wilson et al. 2000), multidimensional scaling (Roy et al. 1994; García-Moreno et al. 1996; Figure 4 of this paper), log likelihood (Wilson et al. 2000), factorial correspondence (Wheeldon et al. 2010), probability of identity (Wilson et al. 2000), and STRUCTURE analyses (Koblmüller et al. 2009a; Wilson et al. 2009; Fain et al. 2010; Wheeldon et al. 2010). Eastern wolves are also distinguishable in studies that include *C. lupus* from northern Ontario (Rutledge et al. 2010b). Despite the expectation that linearity between genetic distance measures and geographic separation is lost when samples are far apart (Paetkau et al. 1997; Schwartz and McKelvey 2009), genetic distance measures are greater for comparisons between western gray wolves and eastern wolves than for comparisons between paired samples with substantial eastern wolf composition (Table 3). There is geographic discontinuity between western gray wolf and eastern wolf samples in some studies, but greater divergence between eastern wolves and gray wolves is also found in studies that include grey wolf samples in close proximity to eastern wolves (Roy et al. 1994; Grewal et al. 2004; Wilson et al. 2009; Rutledge et al. 2010b).

Private alleles are another indication of the relative isolation of populations (Slatkin 1985). These are alleles that are found within a single locality or population, and it is inferred that they are locally restricted owing to isolation. Information on private alleles in North American wolf populations is summarized in Table 4. Private alleles are determined only with respect to other wolf populations; many of these alleles are shared with coyotes. The number of private alleles is much higher in populations including eastern wolf (southern Quebec and the western Great Lakes states) than in western gray wolves. Some private alleles are at relatively high frequencies, which is a further indication of a history of isolation. For example, four such alleles have frequencies ranging from 0.146 to 0.202 in samples of wolves from the western Great Lakes states (Fain et al. 2010), which is consistent with continuing isolation despite a history of admixture.

Single-nucleotide polymorphisms. vonHoldt et al. (2011) used the canine SNP array data set and STRUCTURE to group their large population sample set into the minimum number of clusters representing the ancient phylogenetic divisions between western wolves, eastern wolves, red wolves, coyotes, and dogs. However, Kalinowski

Table 3. Genetic distances based on microsatellite DNA between paired samples of eastern wolf (Southern Quebec, Algonquin, western Great Lakes), other wolves, and coyotes. Genetic distances between samples with substantial eastern wolf representation are indicated in bold. Koblmüller et al. (2009a) used the notation Θ_{ST} to report the coancestry parameter Θ of Weir and Cockerham (1984), which they consider to be generally comparable to F_{ST} , the fixation index of Wright (1951). D is the unbiased genetic distance of Nei (1978).

Comparison	Distance	Measure	Source
Southern Quebec - Minnesota	0.135	D	Roy et al. 1994
Southern Quebec - northern Quebec	0.296	D	Roy et al. 1994
Southern Quebec - western <i>C. lupus</i>	0.251 to 0.519	D	Roy et al. 1994
Great Lakes modern - Great Lakes historic	0.057	Θ	Koblmüller et al. 2009a
Great Lakes modern - western wolves	0.075	Θ	Koblmüller et al. 2009a
Great Lakes modern - eastern coyotes	0.142	Θ	Koblmüller et al. 2009a
Great Lakes modern - western coyotes	0.133	Θ	Koblmüller et al. 2009a
Algonquin - proximal wolf populations	0.024 to 0.055	F_{ST}	Grewal et al. 2004
Algonquin - Abitibi Temiscamingue	0.089	F_{ST}	Grewal et al. 2004
Algonquin - La Verendrye Reserve	0.091	F_{ST}	Grewal et al. 2004
Algonquin - NE Ontario	0.076	F_{ST}	Grewal et al. 2004
Algonquin - western Great Lakes states	0.164	F_{ST}	Grewal et al. 2004
Western Great Lakes states - NE Ontario & Quebec	0.068	F_{ST}	Wheeldon 2009
Algonquin - Frontenac Axis	0.109	F_{ST}	Wheeldon 2009
Algonquin - NE Ontario & Quebec	0.135	F_{ST}	Wheeldon 2009
Algonquin - Manitoba	0.232	F_{ST}	Wheeldon 2009
Algonquin - Northwest Territories	0.238	F_{ST}	Wheeldon 2009
Algonquin - Southern Magnetawan	0.022	F_{ST}	Wilson et al. 2009
Algonquin - Frontenac Axis	0.055	F_{ST}	Wilson et al. 2009
Algonquin - NW Ontario	0.071	F_{ST}	Wilson et al. 2009
Algonquin - NE Ontario	0.073	F_{ST}	Wilson et al. 2009
Algonquin - Minnesota	0.089	F_{ST}	Wilson et al. 2009
Algonquin - Pukaskwa National Park	0.117	F_{ST}	Wilson et al. 2009
Among Minnesota, Wisconsin, and Michigan	0.006 to 0.016	F_{ST}	Fain et al. 2010
Western Great Lakes states - western wolves	0.125	F_{ST}	Fain et al. 2010
Western Great Lakes states - Wisconsin coyotes	0.159	F_{ST}	Fain et al. 2010
Algonquin - NE Ontario	0.105	F_{ST}	Rutledge et al. 2010b
Algonquin - Frontenac Axis	0.052	F_{ST}	Rutledge et al. 2010b
Frontenac Axis - NE Ontario	0.120	F_{ST}	Rutledge et al. 2010b

(2011) recently demonstrated how this approach obscured similarities and differences among human populations. Individuals from genetically divergent populations were clustered together even though they were genetically more similar to individuals in other clusters. Although these cross-cluster genetic similarities were not evident in the output of STRUCTURE, they were detected in pair-wise F_{ST} divergence measurements.

PCA of the canine SNP array data set placed the Great Lakes wolf (eastern wolf) sample closer to gray wolves than to coyotes (vonHoldt et al. 2011, figure 3, figure S4). F_{ST} values between the Great Lakes sample and other North American *Canis*

samples range from 0.05 for western gray wolves to 0.11 for Mexican wolf, red wolf, and coyote. In comparison, F_{ST} values among coyotes from different regions (midwestern–southern, northeastern, and western) range from 0.02 to 0.05 (vonHoldt et al. 2011, table S3). Successive STRUCTURE analyses grouped the Great Lakes sample with wolves, rather than coyotes, beginning at $K = 3$, although substantial assignment to coyote ancestry is evident. Assignment of gray wolf ancestry to individual Great Lakes wolves ranged from about 50% to 100%. vonHoldt et al. (2011) conclude that Great Lakes wolves are genetically distinct from western gray wolves.

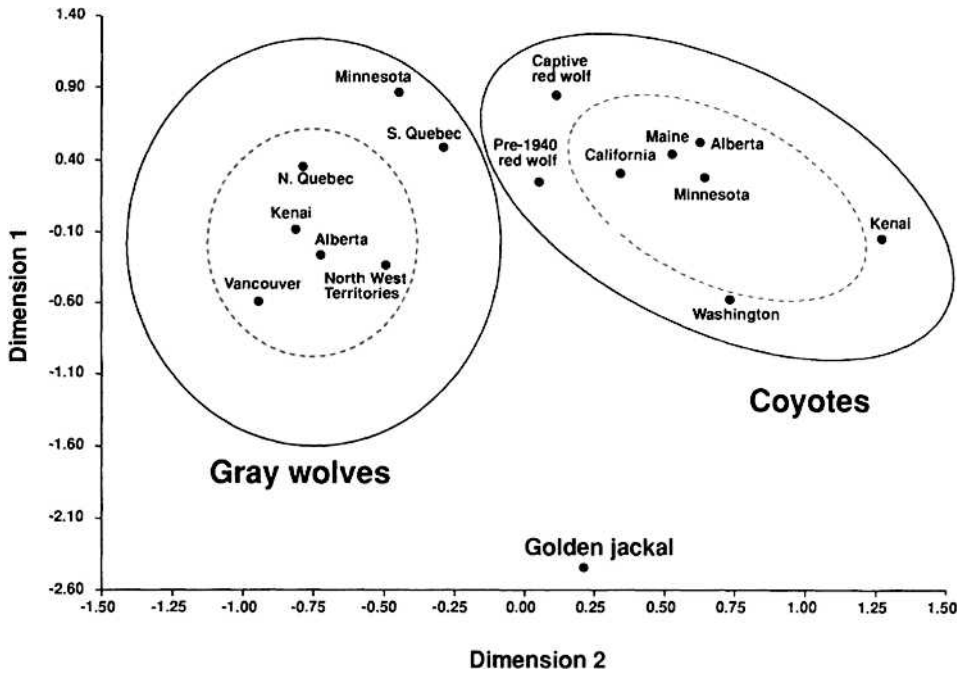

Figure 4. Multidimensional scaling plot based on 10 microsatellite DNA loci (figure 3 of Roy et al. 1996). Confidence ellipses are indicated by dashed (95%) and solid (99%) lines. ©John Wiley and Sons. Used with permission. Samples that likely include eastern wolves (Minnesota and southern Quebec) are distinguished from gray wolves.

Table 4. Private alleles among wolf populations with respect to populations covered in each cited source. Values representing eastern wolf are in bold.

Sample	No. of			Source
	Private alleles	Loci	Individuals in sample	
Southern Quebec	5	10	24	Roy et al. 1994
Minnesota	12	10	20	Roy et al. 1994
Northern Quebec	1	10	20	Roy et al. 1994
Alberta	1	10	20	Roy et al. 1994
Vancouver Island	0	10	20	Roy et al. 1994
Northwest Territories	3	10	24	Roy et al. 1994
Kenai, Alaska	0	10	19	Roy et al. 1994
Western Great Lakes states	14	8	124	Fain et al. 2010
Alberta	2	8	26	Fain et al. 2010
British Columbia	0	8	41	Fain et al. 2010
Alaska	2	8	39	Fain et al. 2010
Algonquin	4	12	128	Rutledge et al. 2010b
Northeast Ontario	5	12	51	Rutledge et al. 2010b
Frontenac Axis	4	12	38	Rutledge et al. 2010b
Alaska and western Canada	5 ^a	11	221	Weckworth et al. 2005
W. Montana (from Alberta founders)	6	10	91	Forbes and Boyd 1996

^a Average per population.

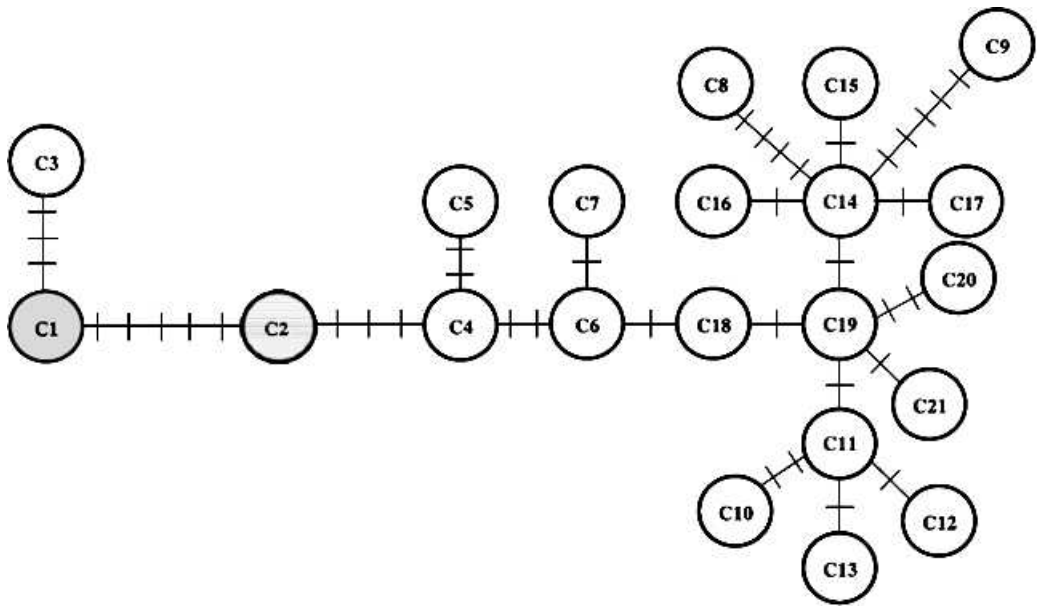

Figure 5. Minimum spanning tree for control-region haplotypes from eastern wolves (figure 5A of Wilson et al. 2000). *Canis lycaon* haplotypes are C1, C3, C9, and C14; it shares C19 with *C. rufus* and with coyotes. *C. rufus* has haplotypes C2 and C19. The remaining are coyote haplotypes not found in either wolf. This illustrates a divergence of eastern wolf and red wolf from coyotes and the results of coyote introgression (C19) in both. Credit: P. J. Wilson et al., 2000, DNA profiles of eastern Canadian wolf and the red wolf provide evidence for a common evolutionary history independent of the gray wolf, *Canadian Journal of Zoology* 78(12):2156–2166. ©2008 NRC Canada or its licensors. Reproduced with permission.

Several features of the sample from the Great Lakes region make it difficult to evaluate the taxonomic significance of the SNP data. The Great Lakes sample is small ($n = 19$), and except for two individuals from Algonquin Provincial Park, their geographic origins within the region are identified only to the level of province or state. Mitochondrial DNA and Y-chromosome lineage markers (discussed in the next section) have been the primary basis for recognizing an admixed population including both eastern wolf and gray wolf in the Great Lakes states region (Wilson et al. 2000; Fain et al. 2010; Wheeldeon et al. 2010), yet the mtDNA and Y-chromosome haplotype composition of the sample used for SNP analysis was not reported. This sample likely included both eastern and gray wolves, which is consistent with the observation that the proportion of gray wolf ancestry varies greatly among individuals in the sample. The eastern wolf has been interpreted as having a common ancestry with the coyote (Wilson et al. 2000), so the gray wolf–coyote admixture in the Great Lakes sample would also be consistent with gray wolf–eastern wolf admixture. The inadvertent inclusion of gray wolves in the Great Lakes sample (e.g., 11 individuals were from Minnesota, which is known to have a high *C. lupus* influence [Mech and Paul 2008; Mech 2010]) would increase the similarity between the Great Lakes sample and western gray wolves, just as it has in the

morphometric analysis by Nowak (1995). Finally, the first two axes of the PCA (vonHoldt et al. 2011, figure 3) account for relatively little of the variance (10% and 1.7%, respectively); the first principal component separates dogs from the wild canids, but does not separate wolves from coyotes. This separation of dog from wolves, from which they were derived, indicates that signatures of genealogical history that might be detectable in this analysis can be labile over the time period since dogs were domesticated.

A re-analysis of the SNP data of vonHoldt et al. (2011) by Rutledge et al. (2012) was published while the current paper was in production. Rutledge et al. (2012) critique the two-species model that vonHoldt et al. (2011) offered to explain the origin of Great Lakes wolves and red wolves in North America (i.e., hybridization between *C. lupus* and *C. latrans*). Rutledge et al. (2012) demonstrate that including over 900 dogs in the vonHoldt et al. (2011) analysis of just 200 wolves and 60 coyotes was inappropriate, and they analyzed the same 48,000 SNP panel, but in 154 individuals from the subgroups of the vonHoldt et al. (2011) sample set relevant to the question of Great Lakes wolf and red wolf ancestry: western coyotes, midwestern coyotes, northeastern coyotes, western gray wolves, Algonquin wolves, Great Lakes wolves, and red wolves. Moreover, Rutledge et al. (2012) point out the general failure in vonHoldt et al. (2011) to use the unique mtDNA and

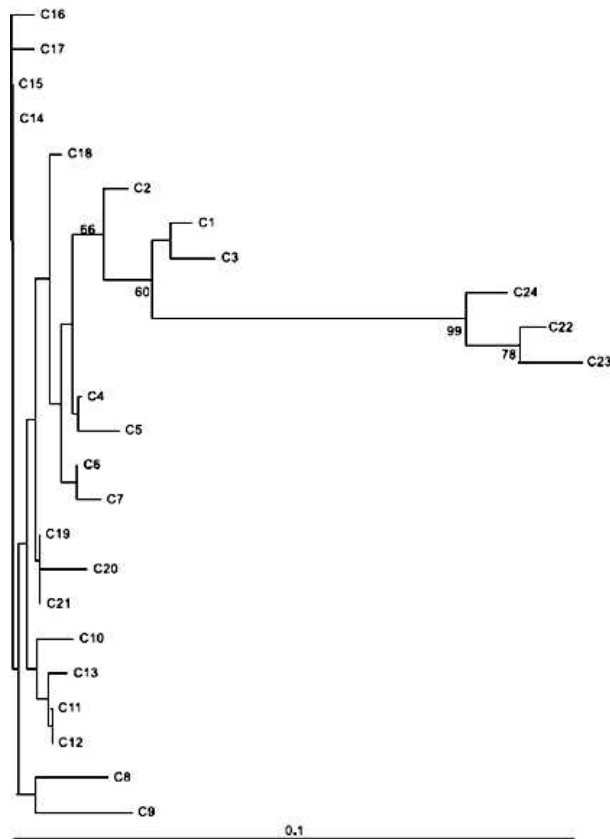

Figure 6. Neighbor-joining tree of mtDNA control-region haplotypes (figure 5B of Wilson et al. 2000). The long branch extending to the right (C22, C23, C24) represents *Canis lupus*. *C. lycaon* and *C. rufus* haplotypes are as identified in the caption for Figure 8 of this paper. Remaining haplotypes are coyotes. Scale represents 0.1 (or 10%) sequence divergence. This illustrates the divergence between gray wolves and eastern wolves, and the affinity of the latter with coyotes. Credit: P. J. Wilson et al., 2000, DNA profiles of eastern Canadian wolf and the red wolf provide evidence for a common evolutionary history independent of the gray wolf, *Canadian Journal of Zoology* 78(12):2156–2166. ©2008 NRC Canada or its licensors. Reproduced with permission.

Y-chromosome haplotypes of eastern wolves as criteria for inclusion in the sample set. Although vonHoldt et al. (2011) did establish that the two critical Algonquin individuals in the analysis exhibited eastern wolf mtDNA, there was no other information as to their actual origin (i.e., eastern wolf, eastern coyote, or first generation hybrid between an Algonquin eastern wolf and either a gray wolf–eastern wolf hybrid or a coyote). Nonetheless, their PCA and neighbor-joining analysis of the genome-wide SNP data in vonHoldt et al. (2011) from the relevant sample set disagrees with vonHoldt et al. (2011) in that it does not refute a three-species model for North American canid evolution (i.e., *C. lupus*, *C. lycaon*, *C. latrans* with hybridization).

Mitochondrial and Y-chromosome haplotypes. Studies using these maternally and paternally inherited lineage markers generally agree that *Canis* of the Great Lakes region can be attributed to three clades:

one representing *C. lupus*, one coyotes, and the third representing members of wolf populations attributed to eastern wolf (Wilson et al. 2000; Koblmüller et al. 2009a; Fain et al. 2010; Wheeldon et al. 2010; Figures 5, 6, and 7 of this paper). The current wolf population of the western Great Lakes includes haplotypes from both *C. lupus* and eastern wolf clades, with eastern wolf haplotypes predominating (Tables 5 and 6). However the unique, “coyote-like” eastern wolf haplotypes of the Great Lakes region may have originated, there seems to be agreement that they support the existence of an “endemic American wolf” (Leonard and Wayne 2008), unique ecotype, or unique taxon (Koblmüller et al. 2009a) in the region, although the modern population is admixed (Wilson et al. 2000; Leonard and Wayne 2008; Koblmüller et al. 2009a).

Wilson et al. (2000) view the relatively large lineage divergence in mtDNA of the eastern wolf from gray wolves to the north and west as sufficient

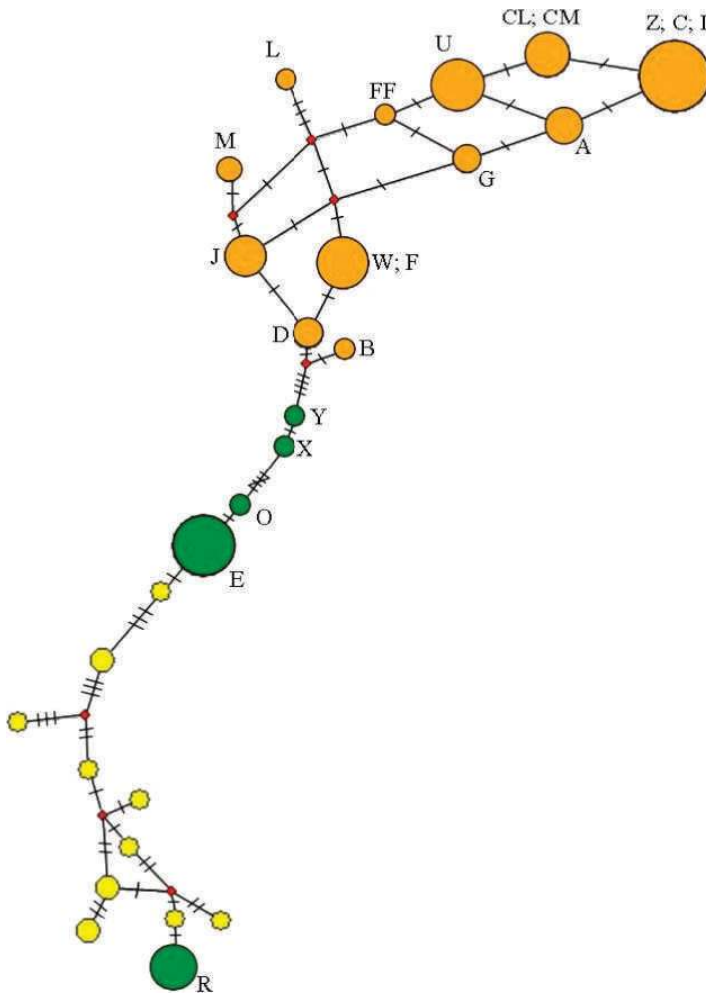

Figure 7. Median-joining network of Y-chromosome haplotypes of western wolves, western Great Lakes states wolves, and Wisconsin coyotes (figure 4 of Fain et al. 2010). This illustrates the divergence between eastern wolf and gray wolf haplotypes, the affinity of eastern wolf to coyotes, and ancient introgression (represented by haplotype *R*) of eastern wolf by coyote ancestors. Green = *C. lycaon*; yellow = coyotes; orange = *C. lupus*. ©Springer. Used with permission.

to recognize eastern wolf as a separate species. Control-region mtDNA haplotype sequence divergence between eastern wolves and western *C. lupus* was 8% (Wilson et al. 2000, p. 2159), compared with the average sequence divergence of 2.9% among major clades of *C. lupus* (Vilà et al. 1999). In other studies (summarized in Table 7 in this paper), sequence divergences between eastern wolves and western gray wolves are about an order of magnitude larger than within-species divergences. Within-species sequence divergences this large appear to be rare in mammals (Avise et al. 1998), and are likely the result of long isolation. Following the hypothesis of Wilson et al. (2000), a specifically distinct eastern wolf evolved in North America from a common ancestor with coyotes rather than from a more immediate common ancestor with *C. lupus*,

which evolved in Eurasia (Kurtén and Anderson 1980; Wayne and Vilà 2003).

Both mtDNA and Y-chromosome haplotypes place eastern wolves in monophyletic clades that are highly divergent from those of gray wolves. Because eastern wolves are phylogenetically more associated with coyotes, inclusion of eastern wolves in the same species with gray wolves would make the latter paraphyletic with respect to coyotes, which violates strict phylogenetic species criteria. Alternative explanations for paraphyly of a *C. lupus* that includes the eastern wolf involve incomplete lineage sorting, and hybridization with coyotes. Incomplete lineage sorting within a broadly defined *C. lupus* is not a likely explanation for paraphyly because it is usually associated with speciation events more recent than the ancient divergence suggested by the highly

Table 5. Distribution of mtDNA control-region sequence haplotypes among wolves and coyotes (*Canis* spp.) in North America. The number of individuals and respective haplotypes observed are indicated for each locality sample: coastal locations in Alaska (AK) and British Columbia (BC) and interior locations in Alaska; Yukon; Northwest Territories (NWT); British Columbia; Alberta (ALTA); Saskatchewan (SASK); Manitoba (MAN); Minnesota, Wisconsin, and Michigan (GLS); and eastern Ontario (EONT). The historical *C. l. nubilus* samples were combined from locations in North Dakota, Colorado, Kansas, Nebraska, Oklahoma, and New Mexico; and the historical *C. l. baileyi* samples were combined from locations in Arizona, New Mexico and northern Mexico (Leonard et al. 2005). The species identity of the historical *C. lycaon* and *C. lupus* samples are those given by the authors. Data sources are indicated in the footnotes.

Haplotype	Genbank	Coastal (n = 277)			Interior (n = 973)							Historical samples (n = 77)						
		AK	SEAK	BC	AK	Yukon	NWT	BC	ALTA	SASK	MAN	GLS	EONT	<i>C. l. nubilus</i>	<i>C. l. baileyi</i>	<i>C. lycaon</i>	<i>C. lupus</i>	
<i>lu38^{a,b}, F^c, f</i>	AF812731	—	127 ^c	57 ^a	3 ^a	—	4 ^a	23 ^{a,5c}	—	—	—	—	—	—	3 ^b	—	—	—
<i>lu48^b</i>	AY812733	—	—	—	—	—	—	—	—	—	—	—	—	—	1 ^b	—	—	—
<i>lu49^b</i>	AY812734	—	—	—	—	—	—	—	—	—	—	—	—	—	1 ^b	—	—	—
<i>lu68^{a,d}, H^c</i>	FN298179	—	2 ^c	14 ^a	—	—	—	—	—	—	—	—	—	—	12 ^d	—	—	—
<i>lu32^{a,b}, W6^e, C22^{f,g}</i>	AF005309	—	—	4 ^a	1 ^a	—	25 ^a , 232 ^h	31 ^a	20 ^e , 1 ⁱ	4 ^f	10 ^f , 1 ^g	38 ^e	4 ^j	3 ^b	2 ^b	—	—	—
<i>lu53^b</i>	AY812738	—	—	—	—	—	—	—	—	—	—	—	—	—	1 ^b	—	—	—
<i>lu54^b</i>	AY812739	—	—	—	—	—	—	—	—	—	—	—	—	—	2 ^b	—	—	—
<i>lu11^a</i>	AF005300	—	—	—	—	—	2 ^a	—	—	—	—	—	—	—	—	—	—	—
<i>lu28^{a,b}, A^c, M^c, W7^c, C23^{f,g}</i>	AF005308	54 ^c	—	—	12 ^a , 41 ^c , 3 ⁱ	3 ^c	1 ^a	15 ^a , 7 ^c	—	—	25 ^f	1 ^e	3 ^g	7 ^b	—	—	—	—
<i>lu52^b</i>	AY812737	—	—	—	—	—	—	—	—	—	—	—	—	—	1 ^b	—	—	—
<i>lu67^a</i>	FM201672	—	—	—	—	—	—	1 ^a	—	—	—	—	—	—	—	—	—	—
<i>lu29^{a,i}, B^c</i>	AF005310	18 ^c	—	—	5 ^a , 8 ^c	6 ^c , 1 ⁱ	3 ^a , 57 ^h	2 ^a	—	—	—	—	—	—	—	—	—	—
<i>lu30^{a,i}, L^c</i>	AF005311	—	—	—	4 ^a	2 ^c , 1 ⁱ	—	1 ^c	—	—	—	—	—	—	—	—	—	—
<i>lu31^{a,i}, K^c, W1^e</i>	AF005312	—	—	—	4 ^a , 3 ^c	1 ⁱ	4 ^a	11 ^a , 10 ^c	5 ^e	—	—	—	—	—	—	—	—	—
<i>lu37^a</i>	AY812730	—	—	—	2 ^a , 3 ^c	—	—	—	—	—	—	—	—	—	—	—	—	—
<i>lu61^a, C^c, f, 16^f, W3^e</i>	AY812741	1 ^c	—	—	3 ^a , 9 ^c	—	1 ^a	—	—	20 ^f	1 ^f	—	—	—	—	—	—	—
<i>lu36^a</i>	FM201632	—	—	—	—	—	—	2 ^a	—	—	—	—	—	—	—	—	—	—
<i>G^c</i>	GQ376506	—	—	—	—	1 ^c	—	—	—	—	—	—	—	—	—	—	—	—
<i>N^c</i>	GQ376226	—	—	—	—	—	—	1 ^c	—	—	—	—	—	—	—	—	—	—
<i>lu33^b</i>	AF005313	—	—	—	—	—	—	—	—	—	—	—	—	—	—	4 ^b	—	—
<i>lu47^b</i>	AY812732	—	—	—	—	—	—	—	—	—	—	—	—	—	—	1 ^b	—	—
<i>lu50^b</i>	AY812735	—	—	—	—	—	—	—	—	—	—	—	—	—	—	6 ^b	—	—

Downloaded from <http://meridian.allenpress.com/doi/pdf/10.3996/nafa.77.0001> by India user on 16 August 2022

Table 5. Continued.

Haplotype	Genbank	Coastal (n = 277)			Interior (n = 973)							Historical samples (n = 77)					
		AK	SEAK	BC	AK	Yukon	NWT	BC	ALTA	SASK	MAN	GLS	EONT	<i>C. l. nubilus</i>	<i>C. l. baileyi</i>	<i>C. lycaon</i>	<i>C. lupus</i>
<i>lu51^b</i>	AY812736	—	—	—	—	—	—	—	—	—	—	—	—	—	1 ^b	—	—
<i>C3^{f,j}, C21^e, GL2^{l,m}</i>	FJ213916	—	—	—	—	—	—	—	—	—	4 ^f	18 ^{e▲}	—	—	—	—	5 ^{l,2m}
<i>C13^{h▲,k,n}, C12^{e▲}, GL10^m</i>	FJ213915	—	—	—	—	—	—	—	—	—	—	58 ^{e▲}	7 ^{j▲}	—	—	1 ^k	1 ^{m,1n}
<i>C1^{i▲,g,k,n}, C4^{e▲}, GL1^{l,m}</i>	FJ213914	—	—	—	—	—	—	—	—	—	—	1 ^{e▲}	28 ^{j▲} , 7 ^{g▲}	—	—	7 ^g , 1 ^{k,1n}	5 ^{l,1m}
<i>C9^{g▲,g}</i>	AY267726	—	—	—	—	—	—	—	—	—	—	—	62 ^{j▲}	—	—	—	—
<i>C14^{j▲,g}</i>	AY267731	—	—	—	—	—	—	—	—	—	—	—	52 ^{j▲}	—	—	—	—
<i>C16^{j▲}</i>	AY267733	—	—	—	—	—	—	—	—	—	—	—	1 ^{j▲}	—	—	—	—
<i>C17^{j▲,g}</i>	AY267734	—	—	—	—	—	—	—	—	—	—	—	10 ^{j▲}	—	—	—	—
<i>C19^{j▲,g}</i>	AY267736	—	—	—	—	—	—	—	—	—	—	—	38 ^{j▲}	—	—	—	—
<i>GL3^l</i>	GQ849352	—	—	—	—	—	—	—	—	—	—	—	—	—	—	—	1 ^l
<i>GL5^{l,m}</i>	GQ849354	—	—	—	—	—	—	—	—	—	—	—	—	—	—	—	1 ^{l,1m}
<i>GL6^{l,m}</i>	GQ849355	—	—	—	—	—	—	—	—	—	—	—	—	—	—	—	1 ^{l,1m}
<i>GL8^{l,m}</i>	GQ849357	—	—	—	—	—	—	—	—	—	—	—	—	—	—	—	1 ^{l,1m}

^a Muñoz-Fuentes et al. (2009).

^b Leonard et al. (2005).

^c Weckworth et al. (2010).

^d Muñoz-Fuentes et al. (2010).

^e Fain et al. (2010).

^f Stronen et al. (2010).

^g Wilson et al. (2000).

^h Musiani et al. (2007).

ⁱ Vilá et al. (1999).

^j Grewal et al. (2004).

^k Wilson et al. (2003).

^l Leonard and Wayne (2008).

^m Koblmüller et al. (2009a).

ⁿ Wheeldon and White (2009).

▲ Considered *C. lycaon* haplotype by authors.

△ Considered *C. latrans* haplotype by authors.

divergent haplotypes of eastern wolves and coyotes. In addition, putative paraphyly is geographically localized to the Great Lakes region, and there is no evidence of it elsewhere within the large geographic range of overlap between *C. lupus* and coyotes.

That leaves hybridization as the remaining explanation for the paraphyletic inclusion of “coyote-like” Y-chromosome and mtDNA haplotypes in *C. lupus*. Koblmüller et al. (2009a) recognize the eastern wolf as a form of *C. lupus* that owes its divergent genetic features to hybridization with coyotes, both ancient and ongoing, rather than to a long period of evolution as a separate lineage

independent of *C. lupus*. A problem with recent coyote introgression as an explanation for the divergent mtDNA haplotypes of the eastern wolf is that these haplotypes are not found in coyotes, except those that have recently hybridized with the eastern wolf in southern Ontario and now occupy the northeastern United States (Kays et al. 2009; Rutledge et al. 2010b). The coyote-introgression hypothesis requires that the coyotes involved were of Y-chromosome and mtDNA haplotype clades that have subsequently become extinct. Although there is evidence, discussed later, of introgression of ancient coyote lineages that are now found only in the

Table 6. Distribution of Y-chromosome microsatellite haplotypes among wolves, coyotes, and dogs in North America. The number of individuals and respective haplotypes observed are indicated for each locality sample: Alaska (AK); Northwest Territories (NWT); British Columbia (BC); Alberta (ALTA); Great Lakes states of Minnesota, Wisconsin, and Michigan (GLS); Texas (TX); and selected domestic dogs. Haplotypes were derived from the dog Y-chromosome microsatellite loci *MS34A*, *MS34B*, *MS41A*, and *MS41B* (Olivier and Lust 1998; Olivier et al. 1999; Sundqvist et al. 2001). Data sources are indicated in the footnotes.

Haplotype	Locality									
	AK <i>C. lupus</i>	NWT <i>C. lupus</i>	BC <i>C. lupus</i>	ALTA <i>C. lupus</i>	GLS <i>C. lupus</i>	GLS <i>C. lycaon</i>	<i>C. l.</i> <i>baileyi</i> ^a	<i>C.</i> <i>rufus</i> ^a	<i>C. latrans</i> TX	<i>C.</i> <i>familiaris</i> NW, OW
E ^b	—	—	—	—	—	29 ^b	—	—	—	—
O ^b	—	—	—	—	—	2 ^b	—	—	—	—
R ^b	—	—	—	—	—	10 ^b	—	—	—	—
H7 ^c , H1 ^d	—	—	—	—	—	—	—	1 ^d	—	202 ^c
H15 ^d	—	—	—	—	—	—	—	4 ^d	2 ^d	—
H28 ^d , G ^b	—	—	—	—	—	—	6 ^d	—	—	—
H29 ^d	—	—	—	—	—	—	10 ^d	—	—	110 ^c
H30 ^{e,f} , I ^b	1 ^e , 1 ^b	32 ^f	5 ^b	12 ^b	—	—	—	—	—	—
H31 ^{e,f}	—	1 ^e , 8 ^f	—	—	—	—	—	—	—	—
H32 ^{e,f} , Z ^b	3 ^e , 3 ^b	2 ^e , 21 ^f	—	—	7 ^b	—	—	—	—	—
H33 ^{e,f} , A ^b , U ^b	3 ^e , 1 ^b	18 ^f	A1 ^b , U4 ^b	—	A6 ^b , U10 ^b	1 ^b	—	—	—	—
H34 ^{e,f}	—	6 ^e , 19 ^f	—	—	—	—	—	—	—	—
H35 ^{e,f} , W ^b	—	2 ^e , 32 ^f	—	—	1 ^b	—	—	—	—	—
H36 ^{e,f} , F ^b	2 ^e , 1 ^b	20 ^f	—	1 ^b	4 ^b	1 ^b	—	—	—	—
H37 ^e	2 ^e	—	—	—	—	—	—	—	—	—
H38 ^{e,f} , J ^b	—	1 ^e , 28 ^f	3 ^b	2 ^b	4 ^b	—	—	—	—	—
H39 ^{e,f} , L ^b	1 ^e , 1 ^b	1 ^e	—	—	—	—	—	—	—	—
H40 ^e	—	1 ^e	—	—	—	—	—	—	—	—
H41 ^f	—	2 ^f	—	—	—	—	—	—	—	—
H44 ^f	—	1 ^f	—	—	—	—	—	—	—	—
H45 ^f	—	1 ^f	—	—	—	—	—	—	—	—
H50 ^f	—	17 ^f	—	—	—	—	—	—	—	—
H52 ^f	—	5 ^f	—	—	—	—	—	—	—	—
H53 ^f	—	1 ^f	—	—	—	—	—	—	—	—
H55 ^f , D ^b	—	1 ^f	—	—	2 ^b	—	—	—	—	—
H58 ^f	—	2 ^f	—	—	—	—	—	—	—	—
H59 ^f	—	1 ^f	—	—	—	—	—	—	—	—
B ^b	—	—	1 ^b	—	—	—	—	—	—	—
M ^b	1 ^b	—	—	—	—	—	—	—	—	—

^a Experimental population.

^b Fain et al. (2010).

^c Bannasch et al. (2005).

^d Hailer and Leonard (2008).

^e Sundqvist et al. (2006).

^f Musiani et al. (2007).

eastern wolf, such instances appear to be rare. The rarity of ancient coyote–eastern wolf introgression indicates that eastern wolves have been evolving as a separate lineage for a considerable time.

There is also disagreement among researchers on whether introgression is ongoing between coyotes

and wolves in Minnesota, Wisconsin, and Michigan. Those favoring ongoing hybridization view western coyotes that have recently moved eastward as the source of the unique but “coyote-like” mtDNA and Y-chromosome haplotypes in eastern wolves (Lehman et al. 1991; Leonard and Wayne 2008;

Table 7. Mitochondrial DNA sequence divergences between samples of gray wolf and other putative North American species of *Canis* (red wolf, eastern wolf, and coyote). Within-species divergences reported from the same studies are provided for comparison.

Comparison	No. of comparisons	% Sequence divergence		Sequence source	Source
		Mean	Range or SD		
Gray wolf–gray wolf	1	0.6	NA	Restriction sites	Lehman et al. 1991
Coyote–coyote	3	1.5	0.8–2.0	Restriction sites	Lehman et al. 1991
Eastern wolf–eastern wolf	1	0.9	NA	Restriction sites	Lehman et al. 1991
Gray wolf–eastern wolf	4	3.6	3.5–3.6	Restriction sites	Lehman et al. 1991
Red wolf–red wolf	3	0.6	0.4–0.9	Cytochrome <i>b</i>	Roy et al. 1996
Coyote–coyote	10	1.1	0.4–1.7	Cytochrome <i>b</i>	Roy et al. 1996
Gray wolf–gray wolf	3	0.9	0.4–1.3	Cytochrome <i>b</i>	Roy et al. 1996
Gray wolf–coyote	15	4.6	3.9–5.6	Cytochrome <i>b</i>	Roy et al. 1996
Gray wolf–Missouri & Oklahoma red wolf ^a	11	2.3	0–4.7	Cytochrome <i>b</i>	Roy et al. 1996
Gray wolf–Arkansas red wolf ^a	9	4.2	3.2–5.2	Cytochrome <i>b</i>	Roy et al. 1996
Major coyote clades	Not reported	1.7	Not reported	Control region	Wilson et al. 2000
Eastern wolf–coyote	Not reported	3.2	Not reported	Control region	Wilson et al. 2000
Eastern wolf–gray wolf	Not reported	8.0	Not reported	Control region	Wilson et al. 2000
Red wolf–gray wolf	Not reported	8.0	Not reported	Control region	Wilson et al. 2000
Gray wolf–coyote	Not reported	10.0	Not reported	Control region	Wilson et al. 2000
Historical eastern wolf clades	Not reported	Not reported	0.5–4.5	Control region	Leonard and Wayne 2008
Historical eastern wolf–coyotes	Not reported	6.4	± 2.9 SD	Control region	Leonard and Wayne 2008
Historical eastern wolf–gray wolf	Not reported	19.1	± 5.1 SD	Control region	Leonard and Wayne 2008
Eastern wolf–eastern wolf	Not reported	1.5	± 0.8 SD	Control region	Wheeldon 2009
Coyote–coyote	Not reported	2.4	± 0.9 SD	Control region	Wheeldon 2009
Gray wolf–gray wolf	Not reported	2.0	± 0.8 SD	Control region	Wheeldon 2009
Eastern wolf–gray wolf	Not reported	14.8	± 6.9 SD	Control region	Wheeldon 2009
Eastern wolf–coyote	Not reported	4.7	± 1.9 SD	Control region	Wheeldon 2009
Gray wolf–coyote	Not reported	25.4	± 11.7 SD	Control region	Wheeldon 2009

^a Red wolf samples were from historical specimens.

Koblmüller et al. 2009a). The contrasting view of little or no ongoing introgression from coyotes in this area interprets these haplotypes as a consequence of shared ancestry between coyotes and eastern wolves (Wilson et al. 2000; Wheeldon and White 2009; Fain et al. 2010; Wheeldon et al. 2010). The absence of western coyote Y-chromosome or mtDNA haplotypes in the current wolf population of Minnesota, Wisconsin, and Michigan is inconsistent with the hypothesis of ongoing coyote introgression in this area (Fain et al. 2010; Wheeldon et al. 2010).

The view that distinctive “coyote-like” mtDNA haplotypes of the eastern wolf could have resulted from ancient introgression from now-extinct coyote lineages requires a selective sweep. This assumes that the ancestral population of the eastern wolf had haplotypes from the wolf lineage, and therefore of Old World origin, but that it hybridized with ancient coyotes to such an extent that the original wolf-lineage mtDNA haplotypes were entirely replaced

by coyote haplotypes. This requires a mating advantage of female coyotes in coyote–wolf matings, or a strong selective advantage for the mitochondrial genome of coyotes. The general process of haplotype replacement by a selective sweep is sometimes called cytoplasmic capture or mitochondrial capture. It has been reported in various plant and animal taxa (Avice 2004, table 7.6), and can even result in total replacement of the mtDNA of one species by the mtDNA of another (Nevado et al. 2009).

Distinguishing mitochondrial capture from lineage divergence or incomplete lineage sorting can be difficult. Although it does occur, it is uncertain whether it occurs often enough to serve as a general explanation of species-level paraphyly in animal taxonomy. In a review of paraphyly in bird species, McKay and Zink (2010) found that most cases were the result of taxonomic errors or incomplete lineage sorting, with few clear instances involving hybridization. In addition to mtDNA, the eastern

wolf differs from coyote and gray wolf in that it also has distinguishing morphological, ecological, Y-chromosome, and nuclear autosomal DNA characteristics.

Separate wolf and coyote clades are also evident from Y-chromosome haplotypes, with the distinctive haplotypes of eastern wolves basal to the coyote clade (Koblmüller et al. 2009a, figure 2b; Fain et al. 2010; Figure 7 of this paper). As with mtDNA, inclusion of eastern wolf with *C. lupus* forms a paraphyletic group with respect to coyotes. An explanation of the high incidence of coyote-clade, Y-chromosome haplotypes in the eastern wolf through coyote introgression and displacement of wolf-clade haplotypes requires a selective advantage of coyote Y-chromosomes or a mating advantage of male coyotes over male gray wolves, which is the opposite of the more likely polarity of coyote–wolf matings (Lehman et al. 1991).

It is reasonable, based on their relative divergence from coyote mtDNA haplotypes, to regard the most strongly divergent eastern wolf mtDNA haplotypes *C1* and *C3* (Wilson et al. 2000) and Y-chromosome types *E*, *O*, *Y*, and *X* (Fain et al. 2010) as indications of the initial divergence from their common ancestor with the coyote, and the less divergent, “coyote-like” haplotypes mtDNA *C13* (Wilson et al. 2003) and Y-chromosome type *R* (Fain et al. 2010) as representing subsequent, ancient introgression. The more divergent Y-chromosome haplotypes of the eastern wolf appear intermediate between *C. lupus* and coyote in the phylogenetic assessment of Fain et al. (2010; Figure 7 of this paper). In summary, species-level recognition of *C. lycaon*, the eastern wolf, outside the species limits of *C. lupus*, is supported by the phylogenetic distinctiveness of its mtDNA and Y-chromosome haplotypes. Inclusion of the eastern wolf within *C. lupus* would render the latter paraphyletic with respect to the coyote. The alternative explanation, that these distinctive eastern wolf haplotypes are the result of introgression of a *C. lupus* population by coyotes and replacement of wolf-clade haplotypes by coyote haplotypes, is not supported with evidence of these haplotypes in modern coyotes other than those that have recently hybridized with *C. lycaon* in eastern Canada (Rutledge et al. 2010b).

Functional gene loci. Although the animal in the illustration that represents the type for the name *C. lycaon* is black, black or melanistic color seems rare in modern populations attributed to that taxon and is more associated with “boreal” wolves attributed to *C. lupus* (Goldman 1944; Mech and Frenzel 1971; Kolenosky and Standfield 1975). Rutledge et al. (2009) made the intriguing suggestion that the K^B allele at the β -defensin *CBD103* gene for melanism may have entered *C. lupus* by introgression from black wolves (either *C. lycaon* or *C. rufus*) of eastern North America. In any event, if the black color of wolves of

eastern North America is controlled by a single locus, as it is in western *C. lupus* (Anderson et al. 2009), it has minimal value in assessing taxonomic divergence among populations.

Conclusions on species limits of Canis lupus relative to eastern wolf. Available information on morphology, ecology, behavior, and genetics are concordant in supporting the existence of a unique form of wolf native to the Great Lakes region of North America. The small size of this eastern wolf in comparison to gray wolves is consistent with its association with white-tailed deer as its preferred prey among ungulate species, although it is a capable moose predator, and local prey availability is likely to affect diet (Theberge and Theberge 2004). Genetic divergence measures at nuclear microsatellite DNA loci and a relatively high incidence of private alleles indicate that the eastern wolf has maintained cohesion and has had a long, separate evolutionary history from gray wolves. Mitochondrial DNA and Y-chromosome haplotypes indicate that eastern wolves and gray wolves evolved independently as separate lineages for a considerable time, and the geographic distribution of their respective haplotypes still reflect this former separation (Tables 5 and 6). These concordant lines of evidence and the age of lineage separation indicated by mtDNA haplotypes support the proposal of Wilson et al. (2000) that the eastern wolf and *C. lupus* belong to separate species. The taxonomic interpretation best supported by available mtDNA and Y-chromosome haplotype data is that the eastern wolf evolved independently from a common ancestor with the coyote and independently of *C. lupus*.

The recently published analysis of SNP variation in *Canis* (vonHoldt et al. 2011) does not alter our interpretation of gray wolf, eastern wolf, and their interaction in the Great Lakes region. General difficulties with applying that study to questions concerning the taxonomic identity of Great Lakes wolves were previously noted. That study concluded that Great Lakes wolves were genetically distinct and admixed, but attributed the dominant component to gray wolves; yet, there remains a component unique to Great Lakes wolves at $K = 10$ in the STRUCTURE analysis. All recent studies of wolves from the western Great Lakes region (Leonard and Wayne 2008; Koblmüller et al. 2009a; Fain et al. 2010; Wheeldon et al. 2010) reported mtDNA or Y-chromosome haplotypes unique to the region, which we attribute to eastern wolf, along with gray wolf haplotypes. The sample of wolves in the SNP study probably also included individuals with both gray wolf and eastern wolf haplotypes, so the placement of Great Lakes wolves closer to gray wolves in the PCA plots of SNP data may only reflect the gray wolf contribution to admixture rather than the affinities of the preadmixture eastern wolf.

The broad-brush approach of vonHoldt et al. (2011) provides a valuable world-wide perspective on variation in *Canis*, but the taxonomic status of wolves in the Great Lakes region requires a finer scale analysis that explores the interactions among individuals and packs on a more detailed geographic scale (Schwartz and Vucetich 2009). Single-nucleotide polymorphism analysis can contribute to our understanding if applied at this scale and integrated with information on mtDNA and Y-chromosome haplotypes of individual wolves. For example, the SNP composition of males with both eastern wolf mtDNA and Y-chromosome haplotypes can be compared with males with both gray wolf mtDNA and Y-chromosome haplotypes. Rutledge et al. (2012) also identified the need for a more integrated approach for understanding the evolutionary and taxonomic status of the eastern wolf. Single-nucleotide polymorphisms analysis applied at a local scale can reveal a detailed understanding of important features of interspecific hybridization (Fitzpatrick et al. 2009).

The eastern wolf, as *C. lycaon*, has also been recognized as a species-level taxon by Baker et al. (2003) in a recent revision of their checklist of North American mammals north of Mexico. The uniqueness of the Great Lakes wolf population, despite admixture, is recognized even by those who do not favor recognizing it as a separate species (Leonard and Wayne 2008; Koblmüller et al. 2009a). It is remarkable that strong genetic signatures of separate evolutionary history remain detectable in the face of modern admixture of eastern wolves and gray wolves in the western Great Lakes region and eastern wolves and coyotes in the eastern Great Lakes region. It is notable that *C. lupus*, an Old World lineage, appeared in North America >500,000 y ago (Kurtén and Anderson 1980), yet mtDNA haplotypes of historical specimens (Wilson et al. 2003; Leonard and Wayne 2008; Wheeldon and White 2009; Rutledge et al. 2010a) from the Great Lakes region are eastern wolf or coyote-like and not *C. lupus*. The geographic range of the eastern wolf and the extent of its hybrid zone with *C. lupus* can be mapped using the geographic distribution of the mtDNA and Y-chromosome haplotypes of the two species (Wilson et al. 2000, 2009; Fain et al. 2010; Wheeldon et al. 2010; Tables 5 and 6 of this paper). The recognition of the range of eastern wolf extending through Minnesota in the southwest and to Manitoba in the northwest (Stronen et al. 2010) reestablishes the western portion of the geographic range of eastern wolf recognized by Goldman (1944) and Hall (1981) for *C. l. lycaon*.

An historical reconstruction leading to the current relationship between the eastern wolf and *C. lupus* begins with *C. lupus* evolving in Eurasia, while the eastern wolf was evolving in North America from a common ancestor with the coyote (Wilson et al.

2000; Wheeldon and White 2009). North American *C. lupus* is inferred to have evolved in Eurasia based on fossils (Kurtén and Anderson 1980) and on the phylogenetic similarity of its haplotypes to certain Eurasian *C. lupus* (Wayne et al. 1995; Vilà et al. 1999; Wayne and Vilà 2003). At this time, the eastern wolf and Eurasian *C. lupus* would have been reciprocally monophyletic, which is indicative of a species-level distinction that follows strict phylogenetic species concepts and criteria. When *C. lupus* subsequently invaded North America and came into proximity with the eastern wolf, the two species may have immediately started hybridizing, at least to some degree. Ecological isolation has been invoked as an explanation for the persistence of the two species or kinds of wolves (Standfield 1970). Differences in habitat and prey preference have been found to significantly affect the genetic structure of wolf populations in North America (Carmichael et al. 2001; Musiani et al. 2007) and Europe (Pilot et al. 2006). Preference of the eastern wolf for white-tailed deer in eastern deciduous forest habitats, and of *C. lupus* for moose and caribou in more boreal habitats (Standfield 1970), may have limited encounters between the two species. However, with human-mediated conversion of boreal forests to deciduous forest and consequent expansion of white-tailed deer, contacts between the species would have increased. Lowered population densities of wolves as a result of persecution by people would have decreased the likelihood of encountering conspecific mates and increased the likelihood of interspecies matings. This “Allee effect” would have accelerated admixture.

There is little evidence for ongoing or recent hybridization between wolves and coyotes in the western Great Lakes states, but there are strong indications that admixture of eastern wolf and coyote has occurred recently or is ongoing in the eastern Great Lakes region (Kays et al. 2009; Wilson et al. 2009; Rutledge et al. 2010b). The finding of 400–500-y-old “wolves” in archaeological context that have coyote and dog mtDNA (Rutledge et al. 2010a) suggests interbreeding between eastern wolves and coyotes had occurred long before 1919, the earliest historical record of coyotes in southern Ontario (Nowak 1979, p. 15). An admixed population of *C. lupus* and the eastern wolf occurs across an area extending from eastern Ontario to Minnesota and into central Manitoba (Wilson et al. 2000, 2009; Grewal et al. 2004; Fain et al. 2010; Stronen et al. 2010; Wheeldon et al. 2010). The incidence in Minnesota, Wisconsin, and Michigan of 36% of male wolves with the Y-chromosome marker of one species and the mtDNA marker of the other (Fain et al. 2010) indicates that interspecies hybridization has occurred. Eastern wolf mtDNA haplotypes are more common in this area, but the

incidence of markers for *C. lupus* is substantial, especially in western Minnesota. Y-chromosome (paternal) markers of the two lineages are more evenly represented.

Admixture between members of long-separate lineages introduces problems in applying a restrictive standard for reproductive isolation as a criterion for species limits (Templeton 1989).

The existence of such a broad hybrid zone, particularly in the western Great Lakes states, indicates that reproductive isolation is incomplete. Indications of backcrosses between the two wolves have been reported (Koblmüller et al. 2009a; Fain et al. 2010), and may indicate some degree of past or ongoing breakdown in reproductive isolation. At this time, this wolf population remains heterogeneous with respect to the contributions of the mtDNA-Y-chromosome haplotype combinations or microsatellite DNA of these two species. Despite a long history of contact with gray wolf and near-extirpation, the distinctive genetic markers of the eastern wolf persist within a geographically restricted area (Tables 5 and 6). It is not known to what extent hybridization and backcrossing now occur, and therefore whether the breakdown of reproductive isolation is continuing. Conspecific combinations of mtDNA and Y-chromosome haplotypes are more common in male wolves of the western Great Lakes region than would be expected by random mating (Wheeldon et al. 2010), which suggests some constraint on admixture. Without detailed information on the fitness and reproductive success of hybrids, it is not possible to determine the population relationships of the two species and whether they are stable or tending toward the complete merging of gene pools. Both natural and human-caused habitat changes have been implicated in other cases of interspecific hybridization (Mayr 1963, p. 128; Seehausen et al. 1997). Habitat degradation together with human transport of individuals of one species into the range of another has resulted in breakdown in species integrity of the American black duck through introgression from mallards (Mank et al. 2004), and the taxonomic integrity of some populations of California tiger salamanders *Ambystoma californiense* has been compromised by introgression from introduced barred tiger salamanders *Ambystoma tigrinum* (Fitzpatrick et al. 2009). The process by which previously isolated and divergent species experience introgressive hybridization has recently been called “reverse speciation” and identified as a concern in conservation (Seehausen 2006; Hendry 2009). Grant and Grant (2006) have termed as “despeciation” the process by which species of Galápagos Islands ground finches have lost morphological diagnosability through introgressive hybridization. They also suggest that, as environmental conditions change, reproductive isolation may be

strengthened and diagnosability restored in a process they call merge-and-diverge dynamics.

Because the essential features of the hybridization process for *C. lycaon* and *C. lupus* are unknown, it is unknown whether reverse speciation or despeciation is occurring. If populations expand and ecological conditions improve, there could even be a restoration or strengthening of isolating mechanisms. If isolating mechanisms deteriorate, it raises the question of at what point the process of despeciation is considered complete and only one species should be recognized. A precedent for formal taxonomic merging as a result of hybridization is the inclusion of the Mexican duck *Anas diazi* with mallards by the American Ornithologists’ Union (1983), although that action has been questioned by the authors of a later mtDNA study of the mallard complex (McCracken et al. 2001). The possibility of merge-and-diverge dynamics (Grant and Grant 2006) suggests that a taxon should be recognized as long as individuals or populations that represent its genetic distinctness remain. The long period of persistence of distinctive eastern wolf characteristics despite long contact with both *C. lupus* and coyotes indicates that it is premature to conclude that the eastern wolf is no longer an identifiable taxon.

In comments on the study of Koblmüller et al. (2009a), Cronin and Mech (2009) state that taxonomy is subjective at and below the species level and propose the alternative of simply referring to the Great Lakes wolves as a population of mixed ancestry. “Mixed ancestry” encompasses diverse situations ranging from mild introgression to completely merged and homogenized populations, so that descriptor is too imprecise to characterize eastern wolves with the currently available information. We agree with Koblmüller et al. (2009b) that description of hybridization and introgression in the wolf population in the Great Lakes region does not preclude the consideration and recognition of either taxa or ecotypes, and that important information can be lost if taxonomic and ecological contexts are not considered.

Species limits of *Canis lupus* with respect to red wolf

Goldman’s (1937) recognition of the red wolf as a distinct species (*C. rufus*) has been followed by most taxonomic authorities, but the account for the red wolf in Wilson and Reeder (2005) accepts the conclusion of Wayne and Jenks (1991) that the red wolf is a hybrid, and suggests that it should be considered of uncertain taxonomic status. As a compromise, it identifies the red wolf as a subspecies of *C. lupus*. The taxonomic status of the red wolf with respect to *C. lupus* will be evaluated in this section; its taxonomic relationship to the eastern wolf will be considered in the following section.

Morphometrics. On the basis of several discriminant function analyses, Nowak (1979, 2002) found the red wolf to be intermediate between coyotes and gray wolves. His series of skulls from before 1930 show no overlap with coyotes, except in central Texas. Series taken after 1930 show increasing amounts of overlap with coyotes as hybridization progressed, which he attributed to reduced densities of red wolves as a result of human control efforts.

Autosomal microsatellite DNA. Red wolves from the captive population share all microsatellite DNA alleles with coyotes, and only 8% of their alleles are not found in gray wolves (Roy et al. 1994). Red wolves are closer to coyotes than to gray wolves in multidimensional scaling analysis (Roy et al. 1994, 1996; Figure 4 of this paper) and in neighbor-joining trees (Roy et al. 1994, 1996; Wilson et al. 2000) based on genetic distances. Eleven additional historical red wolf samples (pre-1940) extended these results (Roy et al. 1996). Unique alleles were found in red wolves, but they were few compared with those found in similar assessments of coyote and gray wolf populations.

Independent analyses of the red wolf autosomal microsatellite data set from Roy et al. (1994, 1996), in addition to expanded coyote and gray wolf samples, came to different conclusions. Reich et al. (1999) accepted the premise that the red wolf originated from hybridization between coyotes and gray wolves and estimated that the event had occurred as much as 12,800 y ago, but probably within the past 2,500 y. However, Bertorelle and Excoffier (1998) found these same data compatible with a model of the red wolf and coyote as sister species that diverged much more recently than their separation from the gray wolf lineage. Consistent with this, red wolf *DRB1* alleles at the major histocompatibility complex (MHC) are identical or most similar to those of coyote (Hedrick et al. 2002).

Single-nucleotide polymorphisms. Red wolf was also positioned near coyote and separate from gray wolves in a PCA of the canine SNP array data set (vonHoldt et al. 2011). Similarly, F_{ST} calculated from this data set ranged from 0.08 to 0.1 between red wolf and coyote but was 0.12 to 0.18 between red wolf and western and Mexican gray wolves. The same SNP data set was used in an admixture classification of the red wolf genome as originating from western coyote or western gray wolf (SABER, Tang et al. 2006). SABER analysis assigned about 75–80% of the red wolf genome to coyote origin with the remainder assigned to gray wolf. Accordingly, the red wolf was thought to have originated from hybridization between western gray wolves and coyotes, with ancestry being primarily coyote.

An alternative interpretation is that the present red wolf population is similar to the coyote population because red wolf and coyote evolved

from the same evolutionary lineage, and because of recent (20th century) introgression from coyotes. Principal components analysis, STRUCTURE analysis, and F_{ST} values all indicate similarity to coyotes, but differentiation is less than among coyote populations. This relative distinction of red wolf is attributed by vonHoldt et al. (2011) to the contribution of gray wolf to the ancestry of red wolf, but there is little indication of such affinity in the PCA and F_{ST} values. In contrast, ancestry analysis (SABER, Tang et al. 2006) does show significant admixture from gray wolf. However, this analysis was constructed to assign ancestry only to gray wolf and coyote, without consideration of a possible “other” category and, as a result, is not informative on the question of a separate red wolf origin. Moreover, the STRUCTURE analysis does not clearly separate red wolf from coyote until $K = 9$, and at that point red wolves display primarily a unique genetic composition, with no contribution apparent from gray wolves.

Mitochondrial DNA and Y-chromosome haplotypes. The early restriction-site data from mtDNA (Wayne and Jenks 1991) are difficult to interpret because the canids that were tested had been captured while hybridization between red wolves and coyotes was well underway. These individuals were even classified on morphological criteria as red wolves, coyotes, or hybrids. The selected founders of the captive population were found to have the same haplotype as two coyotes from Louisiana. Mitochondrial cytochrome *b* gene-sequence haplotypes developed from six pre-1930 skins that were identified as being from red wolves were distributed evenly among separate wolf and coyote clades (Wayne and Jenks 1991). The three historic specimens in the coyote clade were not identical to any coyote, but all three historic red wolves in the wolf clade exhibited the same gray wolf haplotype. Eleven additional historic samples (pre-1940) extended these results (Roy et al. 1996): eight historical samples comprised three unique sequences in the coyote clade of a parsimony analysis, and one of the three individuals in the gray wolf clade was identical to a gray wolf haplotype, but all three sequences were placed basal to Mexican wolf and western *C. lupus* from Alaska. Although sequence comparisons have found the mtDNA control-region haplotype of the red wolf captive population to be unique (but just two base pairs different from the nearest coyote), it falls within the divergence exhibited by coyotes and has an average divergence from coyotes of 3.24%, compared with an average of 2.79% divergence among coyote haplotypes (Adams et al. 2003; Table 7 of this paper).

Hailer and Leonard (2008) compared the mtDNA control-region and Y-chromosome haplotype exhibited by Mexican wolf *C. l. baileyi*, red wolf, and coyote, which were historically sympatric in central

Texas for evidence of hybridization. The single control-region haplotype found in the captive population of red wolves was in the coyote clade, which was strongly divergent from the wolf clade (including Mexican wolf). Of the five red wolves characterized, four shared a Y-chromosome haplotype with coyotes, while one was identical to a haplotype common among domestic dogs (Bannasch et al. 2005). Interspecies hybridization has had an influence on all three of these species, but the greatest effect has been on the red wolf, perhaps most notably revealed by its mtDNA and Y-chromosome ancestries (Hailer and Leonard 2008).

Functional gene loci. Although Goldman (1944) found black coat color present in red wolf, his only explicit reference was to black wolves in Florida from William Bartram's (1791) account. Of the gray wolf subspecies likely to have once been in proximity to red wolf range, black individuals have been reported in *C. l. nubilus* (Goldman 1944; Mech and Frenzel 1971) but not in *C. l. baileyi* (Goldman 1944). Documentation of black individuals in red wolf is insufficient to address potential connections between gray wolf and red wolf. Hedrick et al. (2000, 2002) attributed the sharing of four *DRB1* exon 2 alleles of the MHC among Mexican wolf and Canadian gray wolf, as well as two alleles among red wolf and Canadian gray wolf, to balancing selection and the maintenance of MHC variation within populations long after speciation. Such trans-species polymorphism makes MHC loci particularly useful for elucidating phylogenetic relationships among closely related species (Klein 1987). Populations with few alleles in common have probably been isolated for a longer time. Similar to the results from mtDNA and Y-chromosome analyses in eastern gray wolves (i.e., *C. lycan*, Wilson et al. 2000; Fain et al. 2010), MHC results indicated that the red wolf was also intermediate to the divergence of gray wolves and coyotes (figure 1, Hedrick et al. 2002).

Diet. Gray wolf and red wolf differ in prey species and diet; gray wolves consume primarily large ungulates, while reports of red wolf diet indicate that they primarily consume smaller mammals, mostly rabbits and rodents (Young 1944; Paradiso and Nowak 1972). However, these sources indicate that red wolves also consume white-tailed deer and domestic ungulates as both carrion and prey species.

Conclusions on species limits of *Canis lupus* with respect to red wolf. Several aspects of the available data hinder clear inferences about taxonomic comparisons of the red wolf and gray wolves. The data are derived from a relatively small number of historical specimens, and from captive populations of red wolf and Mexican wolves each derived from very small numbers of founders. Founder effects and genetic drift have likely affected the genetic composition of the captive populations, which, as a result, are not

likely to reflect historical diversity. Further, it is difficult to separate the results of rare and old incidences of hybridization (e.g., gray wolves, coyotes, or dogs) from the undoubted introgression from coyotes that was occurring at the time the last wild red wolves were rescued (Nowak 1979).

Even with these limitations, a variety of genetic information confirms that most red wolves are closer to coyotes than to gray wolves. This is clear in the nuclear microsatellite DNA data, despite the sharing of many alleles among species and the occurrence of relatively few private alleles in red wolves. Analyses of the canine SNP array data set also indicate a much closer relationship to coyotes than to gray wolves. Some mtDNA cytochrome *b* gene haplotypes from historical red wolf samples are wolf-like, but the red wolf haplotype from the higher resolution mtDNA control region of red wolves in the recovery program is unique within the coyote clade. The Y-chromosome haplotypes from red wolves in the recovery program indicate introgression from both coyote (haplotype *H15*) and domestic dog (haplotype *H1*, Table 6). The morphometric analyses of the chronological series of *Canis* by Nowak (1979) document the historical existence of an identifiable red wolf, followed by the decline in its morphological distinctiveness as hybridization with coyotes progressed. There is very limited information from historical specimens (Wayne and Jenks 1991; Roy et al. 1996), and as yet we do not know the genetic composition of the historical red wolf. However, most red wolf individuals for which we have genetic information are closer to coyotes than to gray wolves. The closer relationship of the red wolf to coyotes than to gray wolves indicates it is outside of the gray wolf lineage and is not within the species limits of *C. lupus*. It does raise the question of whether the red wolf is within the species limits of any members of the greater coyote clade, including the eastern wolf, and this will be evaluated in the next section.

Species limits within the coyote clade

The mtDNA haplotypes of red wolf and some eastern wolves are part of a greater mtDNA clade that includes coyote haplotypes. This section evaluates whether red wolf and eastern wolf are within the species limits of coyotes.

Morphometrics. Nowak's (1979) discriminant function analysis found little overlap between coyotes and early (pre-1930) red wolves. Neither did he find overlap between coyote and eastern wolf (Nowak 1979, 2002, figure 7), which he considered a subspecies of gray wolf. Subsequent analysis of red wolves taken after 1930 document the progression of admixture between red wolf and coyote.

Autosomal microsatellite DNA. STRUCTURE analyses of autosomal microsatellite variation have consistently identified the eastern wolf as a discrete

Table 8. Mitochondrial DNA sequence divergences between putative species (red wolf, eastern wolf, and coyote) within the coyote clade. Divergences between red wolf, eastern wolf, and coyote exceed those among coyote samples.

Comparison	No. of comparisons	% Sequence divergence		Sequence source	Source
		Mean	Range		
Coyote–coyote	3	1.5	0.8–2.0	Restriction sites	Lehman et al. 1991
Eastern wolf–coyote	6	1.5	0.9–2.0	Restriction sites	Lehman et al. 1991
Coyote–coyote	10	1.1	0.4–1.7	Cytochrome <i>b</i>	Roy et al. 1996
Red wolf–coyote	15	1.2	0.9–2.2	Cytochrome <i>b</i>	Roy et al. 1996
Coyote–coyote	Not reported	1.7	Not reported	Control region	Wilson et al. 2000
Red wolf–coyote	Not reported	2.3	Not reported	Control region	Wilson et al. 2000
Eastern wolf–coyote	Not reported	3.2	Not reported	Control region	Wilson et al. 2000
Red wolf–eastern wolf	Not reported	2.1	Not reported	Control region	Wilson et al. 2000
Coyote–coyote	Not reported	2.8	Not reported	Control region	Adams et al. 2003
Red wolf–coyote	Not reported	3.2	Not reported	Control region	Adams et al. 2003

group. The analysis by Wilson et al. (2009) separated Algonquin eastern wolves from the nearby population of coyote-hybrid “Tweed wolves” of the Frontenac Axis and from Texas coyotes as well. STRUCTURE and GENELAND analyses by Rutledge et al. (2010b) indicated that, despite interbreeding, Algonquin wolves remain genetically distinct from the Frontenac Axis population. Rutledge et al. (2010b) also reported a tendency of conspecific mating at Algonquin Provincial Park, perhaps contributing to the reinforcement of reproductive isolation. Other STRUCTURE analyses identified an eastern wolf (or Great Lakes wolf) cluster in comparisons with western coyotes and eastern coyotes (Koblmüller et al. 2009a), and a persistent western Great Lakes states cluster in analyses with sympatric coyotes (Fain et al. 2010; Wheeldon et al. 2010).

Comparisons of the different genetic distance measures reported in these studies further confirm the distinctiveness of the eastern wolf. Values of F_{ST} between coyotes and eastern wolves from Algonquin Provincial Park are greater than between Algonquin wolves and nearby hybridized eastern wolf–gray wolf populations (Grewal et al. 2004), and F_{ST} is high between western Great Lakes states wolves and sympatric coyotes (Table 3). Genetic distance (as measured by Θ) is greater between eastern wolf (Great Lakes wolf) and coyote than between eastern wolf and gray wolf (Koblmüller et al. 2009a; Table 3 of this paper). The same study included a factorial correspondence analysis that found that eastern and western coyotes were much closer to one another than either was to the great majority of eastern wolves (figure 3d of Koblmüller et al. 2009a).

Contemporary and historical red wolves and eastern wolves are outside the 95% confidence ellipse encompassing coyotes, based on a multidimensional

scaling analysis of autosomal microsatellite variation (Roy et al. 1996; Figure 4 of this paper). A southern Quebec sample, which likely has some representation of eastern wolf, was even more distant from the coyote. This pattern of divergence is also evident in a neighbor-joining tree from the same data. The distances between eastern wolves and coyotes (0.216 and 0.341 for historical and captive red wolves, respectively) were greater than the average distances among coyote samples (0.188; Roy et al. 1996). Similar analyses by Wilson et al. (2000) distinguished coyote, eastern wolf, and red wolf from gray wolves, and also distinguished eastern wolf and red wolf from coyotes. These data consistently portray a pattern indicating that coyote, eastern wolf, and red wolf are related, but with the red wolf and eastern wolf as outliers to coyote.

Single-nucleotide polymorphisms. Analyses of the canine SNP array data set (vonHoldt et al. 2011) generally indicated that red wolf and eastern wolf are more divergent from coyote than coyote populations are from one another. A PCA placed the red wolf in a discrete cluster near the coyote, although the genetic bottleneck associated with the founding of the captive red wolf population has very likely contributed to this discreteness. Eastern wolf is more divergent from coyote and the possible inclusion of gray wolf individuals or introgression of gray wolf into the eastern wolf population may have contributed to this divergence. However, two individuals from Algonquin Provincial Park, where mtDNA and Y-chromosome haplotypes indicated minimal gray wolf influence (Rutledge et al. 2010b), were most similar to other eastern wolves and divergent from coyote. The STRUCTURE analysis separated eastern wolf (together with western wolves) from coyote and dog at $K = 3$. Red wolf was not separated from coyote until $K = 9$. Values of F_{ST}

among the three sources of the coyote sample (western, midwestern–southern, and northeastern) ranged from 0.02 to 0.05. Red wolf and eastern wolf were more divergent from coyote ($F_{ST} = 0.08–0.11$).

Mitochondrial DNA and Y-chromosome haplotypes. The early restriction-site analysis of mtDNA of wolves from the Great Lakes region found haplotypes distributed among wolf and coyote clades (Lehman et al. 1991, figure 3). Minimum spanning and neighbor-joining trees of mtDNA control-region sequences grouped unique eastern wolf haplotypes *C1* and *C3* together basal to coyote, but an additional eastern wolf haplotype, *C13*, while not identical to any coyote haplotype, was embedded among coyote haplotypes (Wilson et al. 2000, figure 5; Figures 5 and 6 of this paper; Fain et al. 2010). Mitochondrial DNA sequence divergences were greater between eastern wolf and coyote than among coyote populations (Tables 7 and 8), and similar sequences from historical Great Lakes area wolf specimens confirmed this pattern (Leonard and Wayne 2008). Koblmüller et al. (2009a) reported sharing of haplotypes between coyotes and eastern wolves, but information was not provided on the geographical source of these individuals.

Analyses of mtDNA and Y-chromosome haplotypes from eastern wolves and coyotes of the western Great Lakes states (Fain et al. 2010; Wheeldon et al. 2010; Tables 5 and 6 of this paper) failed to find sharing of haplotypes, although phylogenetic analysis indicated that there may have been rare incidences of hybridization in the past that resulted in a low level of wolf influence on coyotes. Koblmüller et al. (2009a) reported that sharing of Y-chromosome haplotypes by eastern wolves and coyotes is rare. Hybridization between eastern wolves and coyotes in the eastern Great Lakes region has primarily affected eastern coyotes, including those of the northeastern United States (Kays et al. 2009), as well as the “Tweed wolf” of southern Ontario, which Wilson et al. (2009) consider a population of eastern coyote. In a recent study (Rutledge et al. 2010b), coyote mtDNA was found in wolves in Algonquin Provincial Park, but similarly shared Y-chromosome haplotypes were less common. Eastern wolf Y-chromosome haplotypes were more frequent in breeding males than was predicted by random mating, so assortative mating or some other isolating barrier may be playing a role in maintaining a cohesive eastern wolf population despite past interbreeding with gray wolves and coyotes (Rutledge et al. 2010b).

In their study designed specifically to examine coyote and red wolf in a former area of sympatry, Hailer and Leonard (2008) found that the single red wolf mtDNA control-region haplotype from the captive population was not shared with any coyote, but the observed high haplotype diversity of coyotes

suggests that additional variation may remain unsampled. It is significant that red wolf and coyote, in a former area of sympatry and with documented modern hybridization, did not share mtDNA haplotypes. As described earlier, the two Y-chromosome haplotypes found in red wolves in the recovery program reflect coyote and dog introgression (Table 6). As discussed earlier, mitochondrial cytochrome *b* gene sequences were ambiguous with respect to red wolf–coyote divergence. The single control-region haplotype from the captive-breeding program for the red wolf appears within the coyote clade in neighbor-joining trees from relatively basal (Vilá et al. 1999, figure 1; Wilson et al. 2000, figure 5; Figures 5 and 6 of this paper; Wilson et al. 2003; Hailer and Leonard 2008) to embedded among various coyote clades (Adams et al. 2003, figure 2; Fain et al. 2010, figure 3). The basal positions are generally not well-supported.

Functional gene loci. Melanistic or black coyotes are considered uncommon (Bekoff 1977), but some modern black coyotes have been found to carry the dominant black K^B allele at β -defensin locus *CBD103* (Anderson et al. 2009). Reports of black eastern (Schreber 1775) and red wolves (Bartram 1791) are limited to early records, and these individuals may reflect introgression of the K^B allele from dogs (Rutledge et al. 2009). Hedrick et al. (2000, 2002) reported MHC variation at the *DRB1* locus in 51 red wolves from the captive-breeding program and compared the results with those from Mexican wolf ($n = 35$), gray wolf ($n = 13$), and coyote ($n = 48$). Red wolves shared three of their four alleles with coyotes (from Texas and North Carolina) and, as indicated earlier, two of these were also shared with gray wolf. The fourth allele was a single nucleotide different from an allele unique to coyotes. With respect to red wolf–gray wolf relationships, the alleles shared with gray wolves likely reflect ancestral polymorphism maintained by balancing selection (Hedrick et al. 2000, 2002) and not recent gene flow (Klein 1987).

Conclusions on species limits within the coyote clade. The eastern wolf forms a divergent clade basal to the greater coyote clade for both mtDNA and Y-chromosome haplotypes (Wilson et al. 2000; Fain et al. 2010), with additional clades consistent with subsequent, ancient introgression from coyotes. Generally, sequence divergence and the branching patterns of the divergent clades indicate a deeper and older divergence between eastern wolf and coyote than among coyote branches of the greater coyote clade. This agrees with various nuclear microsatellite DNA studies including gray wolves and coyotes of the Great Lakes region that show eastern wolf as an identifiable cluster (Koblmüller et al. 2009a; Fain et al. 2010; Rutledge et al. 2010b;

Wheeldon et al. 2010) and an outlier to coyotes (Roy et al. 1996). Eastern wolves were also divergent from coyotes in the canine SNP array analysis (vonHoldt et al. 2011), although admixture with gray wolves likely contributed to that divergence, as it likely has for coyote–eastern wolf divergence at autosomal microsatellite DNA loci. Eastern wolves and coyotes do not interbreed where they are both sympatric and abundant in the western Great Lakes region (Fain et al. 2010; Wheeldon et al. 2010). In the eastern portion of their range, eastern wolves have experienced some coyote introgression through the maternal line as indicated by mtDNA, but appear to be maintaining a cohesive population in Algonquin Provincial Park, possibly assisted by a preference for intraspecific mating (Rutledge et al. 2010b). Introgression from coyotes through the maternal line likely occurred historically when the eastern wolf population was at lower densities and the availability of conspecific mates was reduced. Reproductive isolation may not be complete in this eastern portion of the eastern wolf range, but the eastern wolf is displaying cohesion and is maintaining itself as a phylogenetically unique lineage in the Great Lakes region, distinct from sympatric coyotes.

Red wolf mtDNA also constitutes a divergent lineage within the greater coyote clade. This is consistent with autosomal microsatellite and canine SNP array data sets that indicate it as an outlier to coyotes. Its Y-chromosome haplotypes are not of phylogenetic value because the *H15* haplotype is identical to a Texas coyote haplotype, whereas the *H1* haplotype is commonly observed in domestic dogs (Bannasch et al. 2005). As a result, the Y-chromosome genetics of contemporary red wolves reflect past introgression from dogs and coyotes. A morphologically discrete and identifiable red wolf has survived severe reduction in its population size and range and subsequent hybridization with coyotes and either dogs or wolf–dog hybrids (Nowak 1979; Adams et al. 2003).

A persistent question concerns the susceptibility of red wolf and eastern wolf to introgression from coyote, while gray wolves appear to be resistant to coyote introgression (for an exception, see Hailer and Leonard 2008) and are generally intolerant of coyotes (reviewed in Ballard et al. 2003). Wilson et al. (2000) proposed that it is the close phylogenetic relationship within the coyote clade between eastern wolf, red wolf, and coyote that explains susceptibility to coyote hybridization. Both red wolf and eastern wolf remain identifiable lineages that have evolved in North America with the coyote. Despite long histories of sympatry with, or proximity to, coyote populations and the ability of *Canis* species to interbreed, evidence of ancient hybridization between these two lineages and coyotes have been rare. Major threats of introgression can be associated with

the recent reduction of wolf population densities, and alteration of natural habitat that once contributed to the isolation of the different lineages.

Relationship of red wolf and eastern wolf

In the previous section, red wolf and eastern wolf were concluded to be lineages divergent from that of the coyote. This section considers whether red wolf and eastern wolf are close enough to be considered a single species under the older name of *C. lycaon*, as proposed by Wilson et al. (2000).

Morphometrics. Nowak (1979) found little morphological overlap between red wolf and eastern wolves. Moreover, eastern wolves from southern Ontario and Quebec were actually morphologically intermediate between gray wolves from western North America and red wolves (Nowak 2002).

Single-nucleotide polymorphisms. Analyses of the canine SNP array data set (vonHoldt et al. 2011) generally document divergence between red wolf and eastern wolf. As indicated in the previous section, PCA, STRUCTURE, and SABER analyses found that red wolves were most similar to coyotes and eastern wolves were nearer to gray wolves. However, contrary to these analyses, F_{ST} estimates indicated red wolf and eastern wolf to be equally as divergent from coyote as from each other ($F_{ST} = 0.08–0.11$; vonHoldt et al. 2011, table S3). For comparison, F_{ST} values among coyotes in this study ranged from 0.02 to 0.05. Limiting the interpretation of the SNP data are the small sample size of the eastern wolf sample ($N = 19$) and the differential influences of admixture on eastern wolf and red wolf.

Functional gene loci. As discussed in the preceding section on species limits within the coyote clade, mention of black or melanistic individuals of eastern wolf and red wolf in historical accounts does not provide sufficient information for evaluating species relationships among these taxa.

Geographic gaps in sampling. The proposal of Wilson et al. (2000) that eastern wolf and red wolf may be the same species is based on similarities in nuclear microsatellite DNA loci and mtDNA haplotypes. Both sets of markers indicate that there is genetic divergence between eastern wolf and red wolf. This divergence could represent gray wolf, coyote, or dog introgression; geographic variation within a single species; or it may indicate genetic discontinuity between two species. Interpretation of the taxonomic significance of this difference is confounded by the large geographic distance between the sources of samples: the red wolf samples are all from descendants of wolves captured in eastern Texas and southwestern Louisiana, while eastern wolf samples were collected at locations >2,000 km away in eastern Canada. There are no genetic samples from intervening areas, except for the

historical samples from Maine and New York, which have eastern wolf mtDNA haplotypes (Wilson et al. 2003). Nowak (2002) identifies a single historical skull from Maine as red wolf based on its morphological features. If these wolves are considered as belonging to two species, this gap in sampling would make it impossible to infer from existing data any possible interactions between them. Although red wolf and eastern wolf are more similar to each other at autosomal microsatellite loci than either is to Texas coyotes or western gray wolves (Roy et al. 1994, 1996; Wilson et al. 2000), microsatellite data have very limited value for this comparison because of the large geographic distances between the sources of the samples and the loss of linearity with geographic distance of common measures of genetic distance (Paetkau et al. 1997). In addition, distances are based largely on allele frequency differences, which have undoubtedly been affected by severe population bottlenecks experienced as the red wolf population declined to near extinction before the founding of the captive population.

Hypotheses involving hybridization. Two very different hypotheses involving hybridization have been proposed to explain the general similarities between red wolf and eastern wolf. Nowak's (1979, 1995, 2002, 2003) morphometric analyses describe eastern wolf, which he considers to be a subspecies of gray wolf, as statistically intermediate between gray wolf and red wolf, with red wolf resembling eastern wolf more than it does any gray wolf. Nowak's (2002) hypothesis that the eastern wolf may have originated as a result of hybridization between red wolf and gray wolf is not supported by the available genetic data. Samples of wolves from Algonquin Provincial Park and the surrounding area, reported by Wilson et al. (2000, figure 5A), have either the *CI* haplotype unique to eastern wolf, or coyote or coyote-like haplotypes, but no haplotypes associated with gray wolf to the north and west. A sample of three individuals from "north of Algonquin Park" (Wilson et al. 2000) included both the eastern wolf *CI* haplotype and gray wolf haplotype *lu32*, which indicates interaction between the species further to the north. Subsequent studies have reported a low incidence of gray wolf mtDNA and Y-chromosome haplotypes in Algonquin Provincial Park (Grewal et al. 2004; Rutledge et al. 2010b). The park is within the range of eastern wolf as recognized by Nowak (2003), and therefore should include a substantially greater percentage of gray wolf genetic markers if hybridization involving that species was a major factor in the origin of the eastern wolf.

Roy et al. (1994, 1996) attributed the genetic similarity between red wolf and eastern wolf to both having hybridized with coyotes. The mtDNA haplotypes initially developed from red wolves and

eastern wolves by restriction analysis were thought to have been derived from coyotes (Lehman et al. 1991). However, subsequent sequencing of the mitochondrial control region identified distinctly different haplotypes in red wolf and eastern wolf, none of which have been found in western coyotes, which were the presumed source of hybridization (Wilson et al. 2000, 2003; Adams et al. 2003; Hailer and Leonard 2008). A mtDNA haplotype is shared by eastern wolf and coyote in the northeastern United States, but it is interpreted as an eastern wolf haplotype that has influenced this eastern coyote population and not the reverse (Kays et al. 2009). As discussed previously, the similarity to coyote mtDNA is more likely the result of a shared evolutionary history with coyotes separate from gray wolves, allowing for some rare instances of ancient introgression.

Phylogenetic relationships. Mitochondrial DNA data could lend support to the proposal of Wilson et al. (2000) that eastern wolf and red wolf are one species if they were found to cluster together within the greater coyote clade. In the minimum spanning network of Wilson et al. (2000, figure 5A; Figure 5 of this paper) the mitochondrial control-region haplotype of red wolf is closer to that of the coyote, but appears in a basal position on the branch leading to eastern wolf. In neighbor-joining and maximum-parsimony trees in analyses that included historical specimens (Wilson et al. 2003), red wolf was no longer basal to eastern wolf, but both formed separate branches basal to coyote haplotypes. Neither did red wolf or eastern wolf cluster together in parsimony (Leonard and Wayne 2008, figure 1b) or neighbor-joining trees (Fain et al. 2010, figure 3) where they were separated by intervening coyote clades. Mean mtDNA control-region sequence divergence between red wolf and eastern wolf (2.1%) exceeds that among coyote samples (1.7% [Wilson et al. 2000; Table 8 of this paper]).

Red wolf and eastern wolf do not share comparable Y-chromosome haplotypes (Hailer and Leonard 2008; Fain et al. 2010; Rutledge et al. 2010b; Table 6 of this paper), but as discussed earlier, four of five red wolves shared a haplotype found in Texas coyotes; this is likely the result of coyote introgression (Hailer and Leonard 2008), and the "gray wolf-like" haplotype reported by Hailer and Leonard (2008) is consistent with dog origin (Bannasch et al. 2005). Consequently, Y-chromosome composition of the captive red wolf population is likely the result of both wolf-dog hybrid and coyote introgression and does not inform the phylogenetic relationship between red wolf and eastern wolf.

Conclusions on the relationship of red wolf and eastern wolf. Eastern wolf and red wolf do not share mtDNA or Y-chromosome haplotypes and do not together form a single group exclusive of coyote

lineages. Morphometric, autosomal microsatellite, and canine SNP array data also indicate divergence between red wolf and eastern wolf; although these conclusions must be qualified by acknowledging the gaps in sampling. Independent evolution of these two taxa from different lineages of coyote-clade ancestors is more consistent with the available genetic data and argues against combining them as a single species but argues for retaining them as *C. lycaon* and *C. rufus*.

Nomenclatural issues. Regardless of present lack of genetic support for combining the taxa, some nomenclatural problems would need to be addressed before uniting *C. lycaon* and *C. rufus*. A compromise approach would be to recognize *C. lycaon* and *C. rufus* as subspecies within the same species. This would require the formal publication of new name combinations for at least one subspecies. In addition, there is significant geographic variation in genetic composition within a more broadly defined taxon that includes both *C. lycaon* and *C. rufus*. Moreover, Texas wolves occupied a very different environment than did wolves in eastern Canada.

The appropriate name for a single species that would encompass both *C. lycaon* and *C. rufus* remains an issue. Wilson et al. (2000) suggested that the name be *C. lycaon*. The rule of chronological priority normally applies in such cases, and the name *C. lycaon* was published earlier than *Canis lupus* var. *rufus* (Table 1). The availability of the older name in this case is uncertain because the type specimen of *C. lycaon* may have been a hybrid (Pocock 1935). As explained by Goldman (1944), the type is the individual portrayed in Schreber's illustration, which was in turn based on a figure published by Buffon in 1761. Article 73.1.4 of the International Code for Zoological Nomenclature (International Commission on Zoological Nomenclature 1999) provides for such instances: "Designation of an illustration of a single specimen as a holotype is to be treated as designation of the specimen illustrated; the fact that the specimen no longer exists or cannot be traced does not of itself invalidate the designation." Because the disposition of the remains of the illustrated specimen is unknown, and the holotype must be of the same group to which the species name is applied, the identity of the specimen portrayed is important.

The type locality was restricted by Goldman (1937) to the vicinity of Quebec, Quebec. Wolves in this region may have already been interbreeding with coyotes or dogs at the time the holotype was collected. Support for earlier hybridization is provided by the presence of either coyote or dog mtDNA in wolf (based on morphology) remains of four individuals from a 400–500-y-old archaeological site in southern Ontario (Rutledge et al. 2010a). Article 23.8 of the International Code specifies that, "a species-group name established for an animal

later found to be a hybrid must not be used as the valid name of either of the parental species, even if it is older than all other available names for them." Pocock's (1935) argument that the type may have been a hybrid was rejected by Goldman (1937), who also believed that a hybrid could still serve as the type, which is in conflict with today's Code.

The next oldest name in Goldman's (1944) synonymy for *C. lycaon* is *Canis lupus canadensis* (Table 1). Allen and Barbour (1937) note that the type specimen for *C. l. canadensis* is a skull illustrated by Blainville and that the locality was given only as Canada, so questions may also be raised about its identity and relation to modern wolf populations in eastern Canada. In this case, the holotype of *C. rufus* (type locality: Austin, Texas) might be more appropriate because hybridization with coyotes would have been unlikely at the time it was described. Nowak (2009) believes that the holotype of *C. lycaon* is actually a specimen of *C. rufus* based on its description as black, which he describes as a well-known coat color in *C. rufus*, but unusual for *C. lycaon*. Black coat color could also indicate that the individual had dog ancestry. Current wolves nearest the *C. lycaon* type locality (vicinity of Quebec), however, have the mtDNA haplotypes of *C. lycaon*. Even if additional evidence should provide support for formally combining these taxa, this issue would need to be resolved before formal changes in taxonomy are made.

The subspecies of *Canis lupus*

The following evaluation and discussion is organized by the remaining (less *C. l. lycaon*) subspecies of *C. lupus* recognized by Nowak (1995). This does not mean that Nowak's classification is accepted without consideration of alternative classifications. The analysis therefore includes consideration of formerly recognized subspecies (e.g., Goldman 1944; Hall 1981) that were reduced to synonymy by Nowak (1995) when patterns of variation within these four subspecies suggest that some finer scale taxonomic subdivision might be recognizable.

Canis lupus baileyi (*Mexican wolf*). Both morphometric and genetic evidence support the distinctiveness of *C. l. baileyi* and its recognition as a subspecies. Genetic analysis of living specimens is limited to the descendants of the founders of the captive-breeding population, thought to be seven individuals (Hedrick et al. 1997). Although the effects of genetic drift and a small founder population have likely increased the observed divergence of living *C. l. baileyi* from other wolves at autosomal microsatellite DNA (García-Moreno et al. 1996), they cannot account for the unique mtDNA haplotype (Roy et al. 1996; Vilà et al. 1999; Table 5 of this paper) and several private microsatellite DNA alleles (García-Moreno et al.

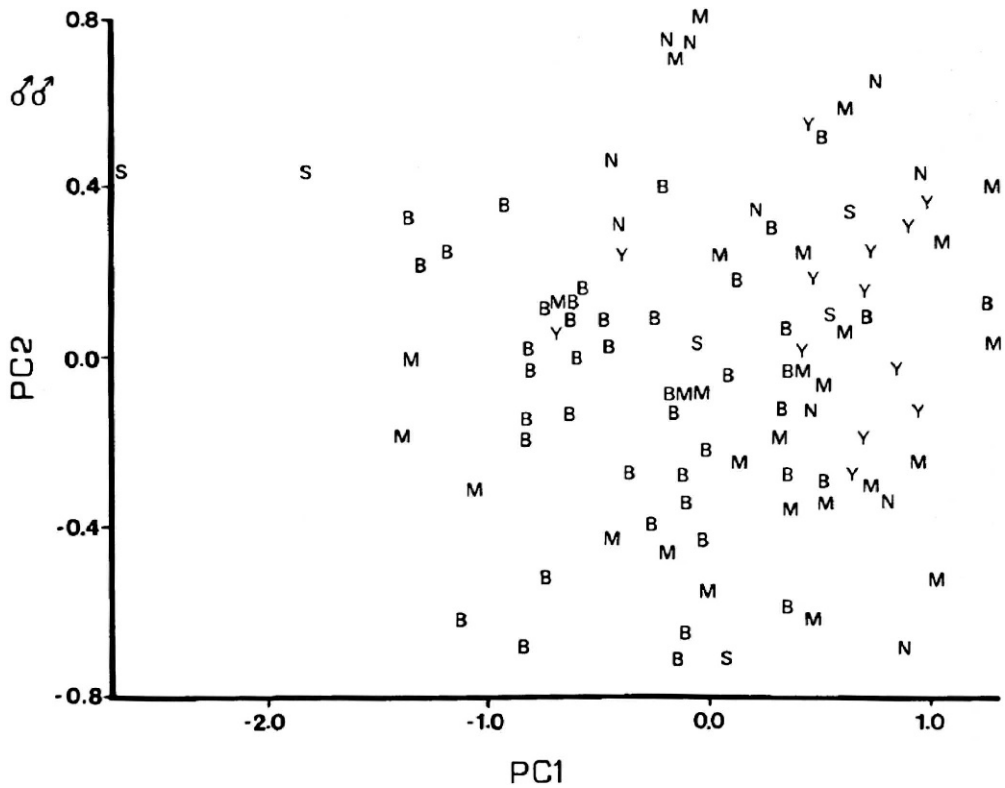

Figure 8. Principal components plot of skulls from male *Canis lupus* from the southwestern United States (figure 2 of Bogan and Mehlhop 1983). This illustrates the overlap in morphology among three subspecies recognized by Goldman (1944) in Arizona and New Mexico. B = *C. l. baileyi*; M = *C. l. mogollonensis*; S = *C. l. monstrabilis*. Credit: Museum of Southwestern Biology, University of New Mexico.

1996) found in *C. l. baileyi*. Additional genetic data from historical, museum specimens (Leonard et al. 2005) have corroborated the results obtained from living individuals, and further indicate that the “southern mtDNA clade” of the Mexican wolf is divergent from other North American wolves. Comparisons of mtDNA sequence divergences among *C. lupus* haplotypes support recognition of *C. l. baileyi* as a subspecies rather than as a species distinct from other *C. lupus*. The predominant *C. l. baileyi* haplotype has a sequence divergence of 2.2% from the closest other North American *C. lupus* haplotype (Wayne and Vilà 2003, p. 228), compared with sequence divergences averaging 2.9% within *C. lupus* (Vilà et al. 1999, p. 2093), 8% between *C. lupus* and either *C. lycaon* or *C. rufus*, and 10% between gray wolf and coyote (Wilson et al. 2000, p. 2159).

Analyses of a canine SNP array data set (vonHoldt et al. 2011) from 10 *C. l. baileyi* from the captive-breeding program also indicate the distinctness of the Mexican wolf. Principal components analysis of the North American gray wolves in the sample (vonHoldt et al. 2011, figure S2) separates Mexican wolf from other gray wolves on the first principal components axis, which accounts for 6.6% of the variance.

Mexican wolf is basal to other North American gray wolves in both a neighbor-joining tree and a phylogram (vonHoldt et al. 2011, figure S5). Values of F_{ST} between Mexican wolf and other western gray wolves is 0.1, which is greater than F_{ST} values (which range from 0.01 to 0.08) among western gray wolves from different regions. In the STRUCTURE analysis, Mexican wolf is the first group to appear (at $K = 6$) as a cluster distinguished from other North American gray wolves. While these results are consistent with other genetic data, a founder effect in establishing the captive Mexican wolf population may also have contributed to the high measures of divergence observed in this analysis.

At the MHC class II locus *DRB1*, individuals from the *C. l. baileyi* captive-breeding program shared three of their five alleles with gray wolves from Alaska and northern and western Canada (Hedrick et al. 2000; Kennedy et al. 2007). As previously discussed, owing to balancing selection, sharing of MHC alleles occurs even among species and is therefore not informative in assessing intraspecific relationships (Hedrick et al. 2000).

There is consensus on the valid taxonomic standing of *C. l. baileyi*, but there is some controversy

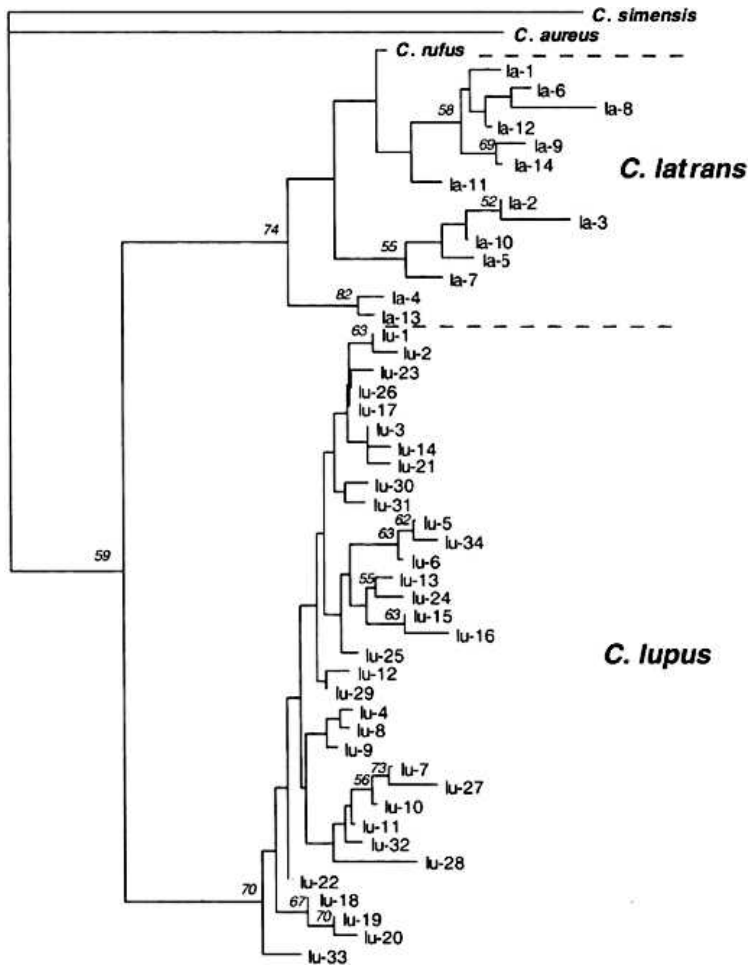

Figure 9. Neighbor-joining tree based on mtDNA control-region sequences of *Canis lupus* from Vilà et al. (1999, figure 1). North American haplotypes are *lu*-28, *lu*-29, *lu*-30, *lu*-31, *lu*-32, *lu*-33. Others are from Eurasia. The haplotype unique to *C. l. baileyi* is *lu*-33. ©John Wiley and Sons. Used with permission.

based on interpretation of morphometric data on the historical boundaries of the subspecies. Nowak (1995) recognized *C. l. baileyi* as a subspecies, but did not adopt Bogan and Mehlhop's (1983) inclusion of *C. l. mogollonensis* and *C. l. monstrabilis* as its synonyms. These different interpretations may be related to larger sample sizes used by Bogan and Mehlhop (1983), who studied 253 skulls of the three subspecies in question, compared with 88 skulls studied by Nowak (1995). It may also be related to Bogan and Mehlhop's (1983, p. 15; Figure 8 of this paper) preference for PCA as a more objective method for assessing overlap in characters than discriminant function analysis, which was used by Nowak (1979, p. 4). Bogan and Mehlhop (1983) also carried out discriminant function analyses on their data and found intermediacy of skulls assigned to *C. l. mogollonensis* between *C. l. baileyi* and more northern wolves. The two different discriminant function

analyses have generally comparable outcomes, so the difference is in interpreting to which subspecies a collection of individuals that is intermediate between recognized taxa should be assigned. Bogan and Mehlhop (1983) and Nowak (1995) agree that the range of *C. l. mogollonensis* in Arizona was a transition zone where *C. l. baileyi* intergraded with more northern *C. lupus*, which is consistent with the limited available genetic data from historical specimens (Leonard et al. 2005). Wolves were long ago extirpated—perhaps by the 1940s (Parsons 1996)—within the ranges of *C. l. monstrabilis* and *C. l. mogollonensis*, so the controversy is now primarily of historical interest.

The phylogenetically closer relationship of *C. l. baileyi* to certain Eurasian wolf populations than to other North American *C. lupus* (Vilà et al. 1999; Wayne and Vilà 2003; Figure 9 of this paper) indicates that contact was secondary between *C. l.*

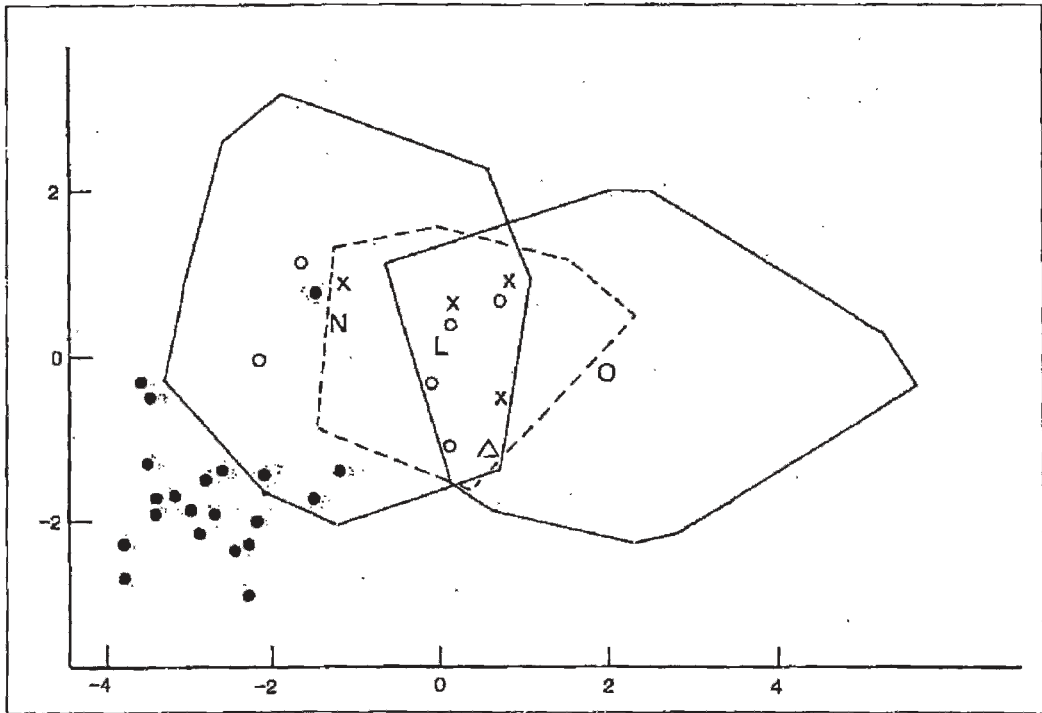

Figure 10. Discriminant function analysis of skulls of some North American *Canis lupus* (figure 7 of Nowak 1995). Axes represent first (horizontal) and second (vertical) canonical variables. Solid lines are limits of the Nowak's southern group (corresponding to *C. l. nubilus*), which is the polygon on the left with center N; and northern group (corresponding to *C. l. occidentalis*), which is the polygon on the right with center O. This illustrates the morphological divergence between the two subspecies. Dots represent individuals of *C. l. baileyi*. Credit: ©Ronald M. Nowak and Canadian Circumpolar Institute Press. Used with permission.

baileyi, as delineated by Bogan and Mehlhop (1983) and the later arriving, more northerly *C. l. nubilus*. Both morphometric (Nowak 1995, p. 385) and genetic data (Leonard et al. 2005) are consistent in indicating that, once *C. l. baileyi* came into contact with more recent *C. lupus* invaders from Eurasia, there was a broad area of reproductive interaction between them. This interaction could have been in the form of a relatively stable and broad zone of intergradation between them, or *C. l. nubilus* could have incorporated genetic elements of *C. l. baileyi* as it rapidly displaced the latter subspecies to the south. General models on plants and animals have demonstrated the process by which local genes are incorporated into an invading population (Currat et al. 2008). The interaction has been described more locally in Arizona by the morphometric data (Bogan and Mehlhop 1983; Nowak 1995), and more expansively by the mtDNA data from historical specimens, where a northern haplotype associated with *C. l. nubilus* was found in Arizona and southern haplotypes associated with *C. l. baileyi* were found as far north as Nebraska. While concordant morphometric and genetic evidence supports the evolutionary and taxonomic distinctness of *C. l. baileyi*, its

predominant prey is elk (Reed et al. 2006; Merkle et al. 2009), which is consistent with the predominance of large wild ungulates in the diet of other gray wolves of western North America.

C. l. baileyi and *C. rufus* do not overlap in morphometric variation of skull features (Nowak 1979). The genetic data, particularly that of Hailer and Leonard (2008), indicate that if hybridization has occurred between these species it has apparently not affected the genetic composition of *C. l. baileyi*, with one exception. The Y-chromosome haplotype *H29* that Hailer and Leonard (2008, figure 3B) found in some *C. l. baileyi* and identified as a wolf haplotype is common in dogs (Table 6). The *C. l. baileyi* with *H29* are all descended from an individual in the "Aragon lineage," which has a nuclear DNA composition (based on microsatellites) that clusters with other *C. l. baileyi* (Hedrick et al. 1997).

Canis lupus arctos (Arctic wolf). The three high Arctic Islands sampled for *C. l. arctos* were grouped together in a neighbor-joining distance analysis based on autosomal microsatellite data (Carmichael et al. 2008, figure 3B), but the authors observed that the island populations exhibited only one private allele, and that their unpublished mtDNA data did not identify any

unique Arctic Islands haplotypes. Based on the assumption that a long isolation in an Arctic refugium (as proposed by Nowak [1983]) should have at least resulted in a higher proportion of unique alleles, Carmichael et al. (2008) concluded that the populations on these Arctic Islands are the result of recent colonization from the mainland. Their interpretation was further supported by low levels of genetic diversity in island wolves. Low levels of microsatellite diversity also affect the reliability of calculated distance measures (Paetkau et al. 1997). The genetic differences observed between Arctic Island and mainland wolves are not likely to be of taxonomic significance.

The morphometric data in support of recognition of *C. l. arctos* also have limitations. The overlap with mainland subspecies (*C. l. nubilus* and *C. l. occidentalis*) is not minimal (Nowak 1995, figure 9), and the large polygons representing the mainland subspecies are likely affected by the very large scale of geographic sampling of the mainland subspecies. A more relevant comparison for evaluating taxonomically significant discontinuity between island and mainland populations would be between island and adjacent, coastal-mainland populations. Coastal-mainland populations do not appear to be well-represented in either morphometric study (Nowak 1995; Mulders 1997).

The genetic data, together with difficulties in interpreting the morphometric data, do not provide clear support for subspecies recognition of *C. l. arctos*. This conclusion is tentative because it is based on lack of supportive data rather than definitive information that these populations are not taxonomically recognizable. The genetic data consist only of autosomal microsatellite DNA and some preliminary mtDNA data that did not detect unique haplotypes in the island populations (Carmichael et al. 2008, p. 885). Y-chromosome and additional mtDNA data could better resolve the relationship between island and mainland populations, and therefore the taxonomic standing of *C. l. arctos*.

Canis lupus occidentalis (*northern timber wolf*). Nowak (1995) defined the range of this subspecies and identified its synonyms by grouping skulls of the subspecies recognized by Goldman (1944) and Hall and Kelson (1959), and then deriving a measure of statistical distance (D^2 of Mahalanobis) between the groups. In comparing these distances, he discerned two major groups across most of western North America corresponding to *C. l. occidentalis* and *C. l. nubilus* (Figures 3 and 10), and reduced other component names within them to synonyms. This consolidation into two major groups is also apparent in the PCA of Skeel and Carbyn (1977), when the subspecies in their study are grouped following Nowak's synonymies (1995).

The major genetic support for *C. l. occidentalis*, as delineated by Nowak (1995) is the phylogenetic

relationship and geographic distribution of mtDNA haplotypes. Phylogenetic analyses (Vilà et al. 1999, figure 1, reproduced in this paper as Figure 9; Leonard et al. 2005, figure 2) identify three major groupings, or clades, which correspond to *C. l. occidentalis*, *C. l. nubilus*, and *C. l. baileyi* in North America. Each of the three major clades also includes Old World wolves, so that the members of the same clade in North America are more closely related to certain Old World wolves than they are other North American wolves from the different clades. This pattern of three separate clades is interpreted as the result of independent invasions of North America by wolves from phylogenetically distinct Old World sources (Vilà et al. 1999). The range of *C. l. occidentalis* from Alaska southward represents the last gray wolf invasion of North America. The overall shape of the range suggests an invasion front that has moved southward to what is now the conterminous United States from an entry point in Beringia. Nine unique mtDNA haplotypes (*lu67* through *N* in Table 5) occur only within the range of *C. l. occidentalis* and are distributed from Alaska to Manitoba. Three haplotypes that are shared with *C. l. nubilus* are discussed in the following section on that subspecies. Overall, the geographic distributions of haplotypes support the general interpretation of "episodes of isolation followed by admixture" (Vilà et al. 1999, p. 2100), but the degree of admixture has not been sufficient to distribute the unique haplotypes of *C. l. occidentalis* beyond its current range.

The autosomal microsatellite study of Carmichael et al. (2008) from widespread localities in Canada also lends support for distinguishing *C. l. occidentalis* from *C. l. nubilus*, with most sampling areas largely attributable to *C. l. occidentalis* (Qamanirjuaq, Saskatchewan, Bluenose West, Cape Bathurst, Manitoba, Alberta, Porcupine, Alaska, Yukon, British Columbia, and Mackenzie) occurring together on the neighbor-joining tree (Carmichael et al. 2008, figure 3B). These sampling areas were not designed to assess subspecies classification, so some straddle Nowak's (1995) boundaries between the two subspecies. The Bathurst and Qamanirjuaq sampling areas appear to also include individuals from Nowak's (1995) range for *C. l. nubilus*, and this may explain the reason these localities do not group closely with other *C. l. occidentalis*. Genetic discontinuity between wolves in the western range of *C. l. occidentalis* and coastal wolves of British Columbia and southeast Alaska is evident in data from autosomal microsatellite loci, canine SNP array analysis, and mtDNA haplotypes (Weckworth et al. 2005, 2010; Muñoz-Fuentes et al. 2009; vonHoldt et al. 2011). These coastal wolves were considered to be *C. l. nubilus* by Nowak (1995, 2002) and are discussed in more detail in the following section.

Some features of the genetic data suggest that the taxonomic standing of *Canis lupus mackenzii*, which

Nowak (1995) and Mulders (1997) treated as a synonym of *C. l. occidentalis* based on morphometric analyses, deserves further consideration. Its distribution is mapped by Goldman (1944) and Hall (1981) as the northern Northwest Territories extending to the Arctic Ocean. The southern boundary in these sources generally coincides with the boundary between tundra–taiga and boreal coniferous forest habitats (Musiani et al. 2007). This boundary also generally coincides with differences in prey specialization, with tundra wolves following migratory caribou and boreal coniferous forest wolves using resident prey (Carmichael et al. 2001; Musiani et al. 2007). The frequencies of wolf coat colors also varied across this boundary, with white coat color predominating to the north, and increasing frequency of black color and its associated K^B allele at the *CBD103* locus increasing to the south (Musiani et al. 2007; Anderson et al. 2009).

There is some genetic discontinuity at the Mackenzie River, which is indicated by autosomal microsatellite variation near the southwest boundary of the mapped range of *C. l. mackenzii* (Carmichael et al. 2001). As measured by Nei's genetic distance, D_S divergence ranges from 0.12 to 0.24 across the river, compared with 0.08 to 0.11 for samples on the same side of the river. These across-river values are smaller than most measurements (Carmichael et al. 2008) across the presumptive eastern boundary of *C. l. occidentalis* with *C. l. nubilus*. Additional autosomal microsatellite data covering the eastern portion of the range of *C. l. mackenzii* (Carmichael et al. 2008), which includes the type locality (Bathhurst Inlet), does not support subspecies standing because the sampling areas (Cape Bathurst, Bluenose West, and Bathurst) that represent the range of *C. l. mackenzii* do not group together in a neighbor-joining analysis (Carmichael et al. 2008, figure 3B). Although there are indications of genetic discontinuity across some portions of the putative boundary of *C. l. mackenzii*, they are not of the magnitude observed between boundaries between *C. l. occidentalis* and *C. l. nubilus*. Comprehensive genetic sampling in a taxonomic context is needed for a clearer understanding of the taxonomic status of *C. l. mackenzii*.

The autosomal microsatellite (Carmichael et al. 2007, 2008) and mtDNA data (summarized in Table 5) indicate limited genetic continuity between *C. l. nubilus* and *C. l. occidentalis*. Although there are the exceptions noted above related to sampling areas not being confined to single subspecies, these data are in general agreement with the morphometric support (Skeel and Carbyn 1977; Nowak 1995) for recognizing *C. l. occidentalis*.

Canis lupus nubilus (“plains” wolf). The vernacular name “plains wolf” was applied to this taxon by Nowak (2003) and is a legacy of Say's (1823) type locality in Nebraska, and of Goldman's use of

“Great Plains wolf” for his concept of the range of the taxon, which was indeed the Great Plains (Figure 2). It is inadequate to describe a taxon that occupies habitats ranging from coastal rain forests of British Columbia to the Arctic of eastern Canada, but rather than coin a new vernacular name, Nowak's terminology is continued here. This is the most difficult and complex subspecies to evaluate because it is, or was historically, in contact with each of the other three *C. lupus* subspecies, *C. lycaon*, and probably *C. rufus*. Some areas included within *C. l. nubilus* range may represent intergrade or contact zones between subspecies. More localized genetic structure generated by habitat and prey preferences (Carmichael et al. 2001, 2007, 2008; Pilot et al. 2006; Musiani et al. 2007) may alternatively obscure or coincide with older patterns of structure that may be of more taxonomic significance. Moreover, this subspecies suffered extirpation over a great part of its range, including all of the conterminous United States except for northeastern Minnesota and Isle Royale, where genetic data have been limited by the relatively few individuals from museum collections that have been characterized.

All *C. l. nubilus* mtDNA haplotypes occur within a major clade separate from the two clades that include the unique haplotypes of *C. l. baileyi* and *C. l. occidentalis* (Vilà et al. 1999; Leonard et al. 2005). Within this clade, six haplotypes (*lu48*, *lu49*, *lu52*, *lu53*, *lu54*, *lu68*) are unique to *C. l. nubilus*, and three (*lu28*, *lu32*, *lu38*) are shared with *C. l. occidentalis* (Table 5). Haplotypes in the *C. l. nubilus* clade extend within the range of that subspecies, as mapped by Nowak (2002), from the Pacific Coast (Muñoz-Fuentes et al. 2009; Weckworth et al. 2010), through areas of the western United States where wolves were extirpated (Leonard et al. 2005), eastward to eastern Ontario (Wilson et al. 2000; Grewal et al. 2004; Rutledge et al. 2010b) and Labrador (Leonard et al. 2005). This supports the phylogenetic relationship of wolves within the wide geographic range attributed by Nowak (1995) to *C. l. nubilus*.

Although three of nine haplotypes of the *C. l. nubilus* clade also occur in *C. l. occidentalis*, this probably overestimates the proportion originally shared by the two subspecies because much of the haplotype diversity in this clade has been revealed by a relatively small number (26) of historical museum specimens (Leonard et al. 2005) that are not likely to be fully representative of the true haplotype diversity of *C. l. nubilus* in areas where they were extirpated. It is most likely that these three haplotypes entered *C. l. occidentalis* by a process similar to that described earlier for the incorporation of *C. l. baileyi* haplotypes by *C. l. nubilus*: incorporation of local genes into an invading population (Currat et al. 2008). Theoretically, as few as three matings involving *C. l. nubilus* females could account for these three haplotypes in *C. l. occidentalis*.

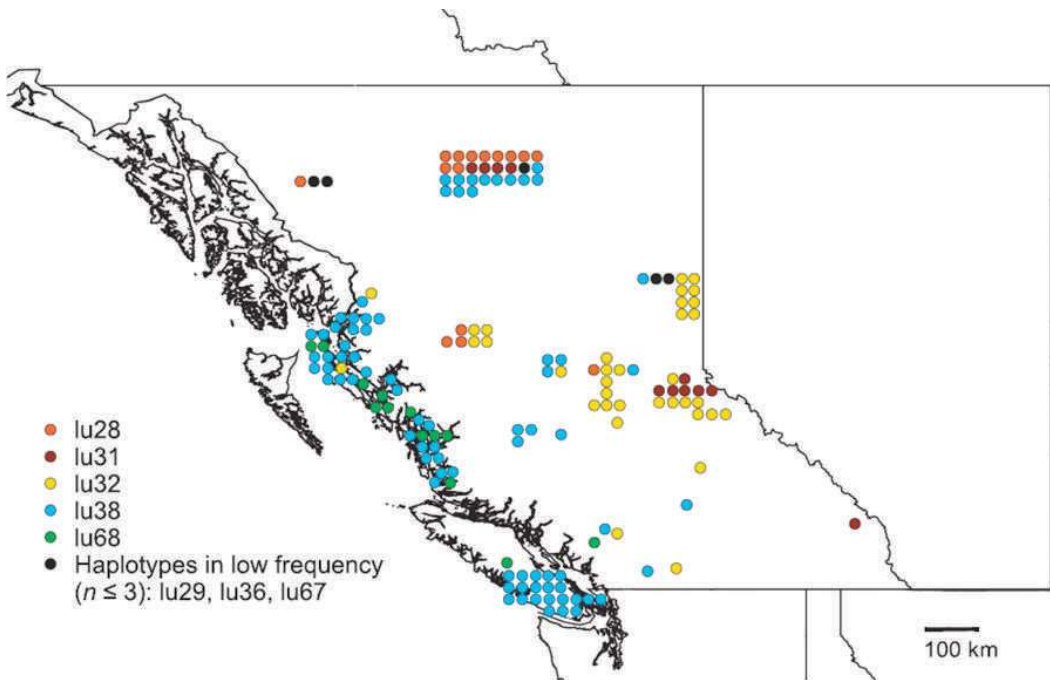

Figure 11. Distribution of control-region mtDNA haplotypes of *Canis lupus* in British Columbia, illustrating that phylogenetic divergence has been maintained between coastal and inland wolves that have been in geographically extensive and long-term contact (figure 3 of Muñoz-Fuentes et al. 2009). ©John Wiley and Sons. Used with permission.

While it was likely to have involved more than three matings, indiscriminant mating should have resulted in more sharing of haplotypes than was observed.

Autosomal microsatellite data provide information on specific areas of contact between *C. l. nubilus* and *C. l. occidentalis*. The neighbor-joining analysis of Carmichael et al. (2008, figure 3A) groups together some northern sampling areas for *C. l. nubilus*, including Baffin Island, the adjacent mainland, and Atlantic (Newfoundland). The Bathurst sampling area is also in this group, but as discussed under *C. l. occidentalis*, it straddles Nowak's (1995) boundary dividing the two subspecies. Unfortunately for taxonomic purposes, this study was designed to explore relationships of Arctic wolves and did not include samples from Ontario or Quebec in the southern Canada range of *C. l. nubilus*.

Another portion of the range in which subspecies assignment is uncertain is the area west of Hudson Bay in Northwest Territories. Skeel and Carbyn (1977) found morphometric affinity with *C. l. occidentalis* from Wood Buffalo National Park, which Nowak (1995) has questioned on the basis of their inclusion of females with samples of males. The Qamanirjuaq sampling area of the autosomal microsatellite study of Carmichael et al. (2008) encompasses an area from Hudson Bay west, which straddles the boundary between the two subspecies. As a possible consequence, its position on the

neighbor-joining tree (Carmichael et al. 2008, figure 3B) is only weakly supported and therefore provides little reliable information on taxonomic standing.

Nowak (1995) considered wolves from the Pacific Northwest of the United States, coastal British Columbia, and southeastern Alaska to be *C. l. nubilus*, and several recent studies address various aspects of these coastal wolves. The following discussion will first address their relationship to inland, or continental, populations attributed to *C. l. occidentalis*; then the relationships among the coastal populations; and finally the relationship of the coastal populations to historical populations of *C. l. nubilus* of the western United States.

Differentiation between coastal and inland wolves in southeastern Alaska has been reported for both autosomal microsatellite (Weckworth et al. 2005) and mtDNA data (Weckworth et al. 2010, 2011). Differentiation between mtDNA haplotypes exhibited by coastal and inland wolves in British Columbia has also been documented (Muñoz-Fuentes et al. 2009; Weckworth et al. 2011; Figure 11 of this paper). An affinity between wolves in western coastal areas of Canada and those in southeastern Alaska was originally shown by morphometric data (Jolicoeur 1959). Coastal populations were closer in morphology to one another than to nearby inland populations (Jolicoeur 1959; Nowak 1983). Nowak (1995) observed that wolves in southeastern Alaska

populations were intermediate between *C. l. nubilus* and *C. l. occidentalis*.

The canine SNP array study of vonHoldt et al. (2011) included a small sample ($n = 3$) of wolves from coastal British Columbia within the range of *C. l. nubilus* as mapped by Nowak (1995). It also included samples within the general range of *C. l. occidentalis*: “boreal forest” (Alaska), “tundra-taiga” (inland Canada), and “Rocky Mountain” (Yellowstone). The western coastal sample was differentiated from other inland gray wolves by PCA (vonHoldt et al. 2011, figure S3). Values of F_{ST} among samples representing *C. l. occidentalis* (Alaska, inland Canada, and Yellowstone) ranged from 0.01 to 0.03, while F_{ST} between these samples and the *C. l. nubilus* sample from coastal British Columbia was an order of magnitude greater (range 0.6 to 0.8).

Muñoz-Fuentes et al. (2009) and vonHoldt et al. (2011) attribute the difference between coastal and inland populations and other patterns of geographic variation within gray wolves to differences in habitat characteristics. Coastal wolves differ from inland populations in this region in their reliance on salmon *Oncorhynchus* spp. and marine mammals, and a combination of habitat preference required to exploit these food resources and evolved resistance to diseases associated with marine food sources may restrict movement between coastal and inland habitats (Darimont et al. 2003, 2008). Differences in habitat can, however, coincide with subspecies boundaries and play a role in maintaining taxonomic distinctions when ranges are contiguous. In these instances, explanations based on habitat variation can also be taxonomically informative. These coastal-inland patterns of genetic and ecological divergence lend support to Nowak’s (1995) boundary between *C. l. nubilus* and *C. l. occidentalis* in the Pacific Northwest.

Three subspecies names recognized by Hall and Kelson (1959) and Hall (1981) for Pacific coastal wolves were considered by Nowak (1995) to be synonyms of *C. l. nubilus*: *C. l. ligoni* (southeast Alaska), *C. l. crassodon* (Vancouver Island), and *C. l. fuscus* (British Columbia except for Vancouver Island, Washington, and Oregon). Coastal populations of southeast Alaska (Weckworth et al. 2010) and British Columbia (Muñoz-Fuentes et al. 2009) share common *lu38* and unique *lu68* haplotypes (Table 5) that comprise a distinct mtDNA phylogroup, inconsistent with their taxonomic distinction as different subspecies. The name *Canis lupus crassodon* has been used to distinguish the wolves of Vancouver Island from mainland wolves (Goldman 1944; Hall and Kelson 1959; Hall 1981). However, there is no genetic support for such taxonomic recognition because recent mtDNA analyses did not differentiate the wolves currently populating Vancouver Island and the coastal mainland of British

Columbia (Muñoz-Fuentes et al. 2009). It is apparent from characterization of historical wolves (haplotype *lu68*) and the current population (haplotype *lu38*) that the extirpation was complete (Muñoz-Fuentes et al. 2009). It is, perhaps, encouraging that the mtDNA haplotype *lu68* found in historical Vancouver Island wolves is also common in coastal mainland wolves today (Muñoz-Fuentes et al. 2010).

The wolf population of coastal British Columbia was probably contiguous with the original populations of coastal Washington and Oregon, which were included by Goldman (1944) with *Canis lupus fuscus*, the type locality of which (near The Dalles, Oregon) was not coastal. Hall and Kelson (1959) included most of coastal British Columbia with the range of this subspecies. Bailey (1936) identified coastal wolves of Oregon as *Canis lycaon gigas* (type locality near Vancouver, Washington). Goldman (1944) included this name as a synonym of *C. lupus fuscus*. Understanding the phylogenetic relationship of coastal British Columbia and southeast Alaska wolves to other populations that Nowak (1995) included in *C. l. nubilus* is greatly impeded by the extirpation of that subspecies in inland portions of the western United States. Genetic study of historical remains from western Oregon and Washington would provide additional information for the taxonomic placements of Pacific Northwest wolves that have been based on traditional morphology and morphometrics.

The strongest indication of the relationship of the coastal populations of southeast Alaska and British Columbia to *C. l. nubilus* is from comparison of their haplotypes with those of the relatively small sample of historical individuals for which genetic data (mtDNA) are available (Leonard et al. 2005). The finding of Muñoz-Fuentes et al. (2009) that coastal British Columbia wolves are less differentiated from inland *C. l. occidentalis* ($\Phi_{ST} = 0.305$) than from the historical samples (Leonard et al. 2005) of *C. l. nubilus* from the conterminous western United States ($\Phi_{ST} = 0.550$) supported their view that coastal wolves were evolutionarily distinct from inland wolves, including *C. l. nubilus*. However, the large proportion of unique, and apparently extinct, haplotypes in the historical sample contributes to an exaggerated measure of divergence between the coastal populations and historical inland *C. l. nubilus*. A different picture emerges when examining the phylogenetic relationships of the haplotypes. The most common haplotype (*lu38*) in coastal British Columbia also occurs in historical Kansas and Nebraska samples (Leonard et al. 2005; Table 5 of this paper), and nearly all coastal haplotypes are in the same phylogroup as the historical western *C. l. nubilus* haplotypes (Weckworth et al. 2010, figure 2). These relationships are consistent with coastal British Columbia and southeast Alaska

wolves being a northward extension of *C. l. nubilus*—the descendants of wolves from a southern Pleistocene refugium that migrated north along the west coast as glacial ice retreated inland approximately 12,000 y ago (Nowak 1983, 1995).

Nowak's (1983, 1995) classification and evolutionary explanation characterizes *C. l. nubilus* as a medium-size wolf that was widespread in North America at the time of arrival of the larger *C. l. occidentalis*. Morphometric analyses by Skeel and Carbyn (1977) provide general support for a comparable distribution of larger and smaller wolves in central Canada. Autosomal microsatellite data (Carmichael et al. 2007, 2008) distinguish *C. l. nubilus* from *C. l. occidentalis* in the northeastern portion of its range, and both microsatellite and mtDNA data (Weckworth et al. 2005, 2010; Muñoz-Fuentes et al. 2009, 2010) distinguish its Pacific Coast populations from inland *C. l. occidentalis*. Historical samples of *C. l. nubilus* from the western United States (Leonard et al. 2005; Table 5 of this paper) have several unique and phylogenetically related mtDNA haplotypes. The available genetic information bearing on the question of subspecies lends general support for *C. l. nubilus* as delineated by Nowak (1995, 2003), at least in the areas covered by those studies.

The range of *C. l. nubilus* included a range of habitats: Pacific coastal, the Great Plains, and the eastern Canadian Arctic. Populations over this range are associated phylogenetically and have a long history in North America, probably preceding *C. l. occidentalis*, but not *C. l. baileyi*. This history of occupation and adaptation is traced in the extensive geographic distribution of related mtDNA haplotypes *lu28*, *lu32*, *lu38*, and *lu68* (Table 5). Intergrade zones involving *C. l. nubilus* were discussed earlier in sections on relationships of *C. lycaon* to gray wolves and on *C. l. baileyi*. General conclusions on these intergrade zones are repeated here. *C. l. nubilus* forms a hybrid zone with *C. lycaon* from eastern Ontario to Minnesota and Manitoba. There was historical contact between *C. l. nubilus* and *C. l. baileyi*, with haplotypes attributable to the latter occurring as far north as Nebraska.

A General Evolutionary Interpretation

The following evolutionary scenario is presented as an overview of the conclusions of this review in the context of the evolutionary history of modern North American *Canis*. Coyotes, *C. rufus*, and *C. lycaon* are modern representatives of a major and diverse clade that evolved within North America, as proposed by Wilson et al. (2000). *C. lupus* arose in Eurasia and invaded North America at least three separate times, with each invasion being by one or more different clades of Eurasian *C. lupus*. These different source clades indicate a dynamic process of clade evolution and changes in the geographic

distributions of clades in Asia during the Pleistocene. The first of these North American invasions was by the ancestors of *C. l. baileyi*, as suggested by Vilà et al. (1999), followed by the ancestors of *C. l. nubilus*, which displaced *C. l. baileyi* in the northern part of its range. While expanding in North America and displacing *C. l. baileyi*, the historical *C. l. nubilus* population gained some mtDNA haplotypes from the latter (Leonard et al. 2005) in a process whereby an invading population is genetically introgressed with local genes. The distribution of *C. l. occidentalis* has the general form of an invading population, and its southward expansion and displacement of *C. l. nubilus* may have continued into historic times. The final invasion, probably postglacial, was by *C. l. occidentalis*, which displaced *C. l. nubilus* in the northern part of its former range. This final phase was undoubtedly more complex, because the biogeography of Beringia is complex, and at least one Beringian lineage of *C. lupus* became extinct without leaving genetic traces in modern wolves (Leonard et al. 2007). *C. lupus* is not morphologically or genetically homogeneous or undifferentiated across North America. An interpretation that wolves of these different lineages have mixed in North America to an extent that the only geographic pattern is isolation by distance is not supported by the geographic distribution of lineage markers. There is geographic structure in genetic composition (Tables 5 and 6) that is consistent with multiple invasions of North America from Eurasia. This geographic structure on a continental scale coincides with the general distributions of the three *C. lupus* subspecies recognized in this review.

Final Comments and Recommendations

The taxonomic recommendations and conclusions stated here are intended to represent the most reasonable interpretations based on the available scientific information. Some conclusions, such as the taxonomic standing of *C. l. baileyi*, are more strongly supported than others. The taxonomic standing for *C. l. arctos* is not confirmed, but important limitations in the available data do not permit more definitive statements on its taxonomic status.

It is possible that further research will provide data that would change certain conclusions reached here. Longer sequences of mtDNA (most studies used approx. 200 to approx. 400 base pairs) could provide more robust resolution of both extant and historical populations. There are many more historical specimens in museum and government agency collections that have not yet had DNA characterized. Y-chromosome haplotypes from additional populations of wolves would provide an additional lineage marker to complement mtDNA data. Single nucleotide polymorphisms are now

being studied in wolves, but most areas of North America remain sparsely sampled (Anderson et al. 2009; Gray et al. 2009; vonHoldt et al. 2011). Genomic approaches have potential to provide vast amounts of information on individual specimens, but those data need to be integrated and reported with lineage and other genetic markers, and it is not yet known how they will affect our understanding of relationships among populations and their taxonomic standing.

Even with expanded application of various genetic markers, geographic coverage or spatial sampling patterns may still limit our understanding of crucial areas. There are sampling concerns on both very broad and more localized scales. A notable example on the broadest scale is the original wolf population of the conterminous United States, which was extirpated outside of northeastern Minnesota and Isle Royale. Without genetic study of additional specimens from collections or possibly as yet unstudied or undiscovered natural deposits of bones or other persistent remains of wolves, the coverage of crucial and underrepresented geographic areas will hinder our understanding of the historical relationships of populations. Additional morphometric studies that use more objective methods and explore more alternative taxonomic arrangements have potential for improving our understanding of evolutionary relationships and their taxonomic implications, especially when integrated with genetic data.

The design of spatial sampling is also important on a more local scale (Schwartz and McKelvey 2009; Schwartz and Vucetich 2009). This is particularly important in cases where both isolation by distance and local barriers (ecological or behavioral) to interaction are suspected to be operating, as in the Great Lakes region. Grouping of spatial genetic data by state or province, for example, can obscure finer scale patterns of contact and interaction between populations with different evolutionary histories. Geographic mapping of haplotypes in the Great Lakes region (e.g., Fain et al. 2010; Wheeldon et al. 2010) provides a more objective portrayal of these interactions and facilitates the identification of areas for further investigation.

To summarize, a comprehensive understanding of North American wolf evolution and taxonomy will require: 1) geographically comprehensive morphometric analyses of wolf morphology using more objective methods than discriminant function analysis; 2) larger samples for both genetic and morphological studies from currently undersampled areas; 3) morphometric and genetic analysis of historical collections now in museum collections; 4) sampling schemes and analyses that take into account the warnings and recommendations of Schwartz and McKelvey (2009) and Schwartz

and Vucetich (2009); 5) transparent reporting in scientific publications of detailed locality information; 6) reporting of morphological and genetic information obtained from all available genetic marker types for individual animals; 7) and integration of all morphological and genetic information in analyzing and interpreting the results of studies.

There is scientific support for the taxa recognized here, but delineation of exact geographic boundaries presents challenges. Rather than sharp lines separating taxa, boundaries should generally be thought of as intergrade zones of variable width. These “fuzzy” boundaries are a consequence of lineages of wolves that evolved elsewhere coming into contact with each other. Historical or modern boundaries should also not be viewed as static or frozen in any particular time. Our understanding of the historical interactions between subspecies or genetically different populations (e.g., Leonard et al. 2005) is that they are dynamic processes and boundaries can shift over time. Even with the great dispersal capabilities of wolves and their interaction in these intergrade zones, genetic indications of the independent evolution of the wolves here recognized as species or subspecies are still discernible on a continental scale.

As stated in the Scope and intent section at the beginning of this review, we have not evaluated nontaxonomic alternatives to subspecies classifications of wolves, such as management units or evolutionarily significant units, or the appropriateness of legal protection of wolves as distinct vertebrate population segments under the Endangered Species Act (USFWS and NOAA 1995). Even with scientific support of its taxonomic validity, a subspecies may or may not be the most suitable unit for protection or management. Weighing the value of subspecies compared with nontaxonomic units requires the evaluation of specific legal, policy, and management objectives that are decidedly beyond the scope of this review. We are aware that taxonomy can have policy and legal implications, but we have carried out his review following the rule that, “[t]he relationship between conservation and taxonomy must be unidirectional; conservation strategies should be influenced by taxonomy, but taxonomy cannot be influenced by conservation priorities” (Bowen and Carl 1999, p. 1013). This review was prepared to provide objective evaluations of controversial issues in wolf taxonomy for the consideration of those who have the responsibility for using the best available scientific information in concert with legal and policy considerations in developing conservation programs.

This review was initiated because of the wide range of views expressed by different researchers and research groups on some major features of relationships and

classification of North American wolves. We have endeavored to be as comprehensive and objective as possible in developing recommendations based on the total information available today, and have sought to reconcile differing interpretations in the literature whenever possible.

Acknowledgments

We thank the following for their reviews of a preliminary draft: D. E. Wilson, K. M. Helgen, M. A. Bogan, M. Culver, B. D. Patterson, P. S. Wilson, M. K. Schwartz, P. Myers, J. A. Cook, R. K. Wayne, R. M. Nowak, L. P. Waits, L. D. Mech, and M. A. Cronin. Comments offered in peer reviews of a later draft by B. S. Arbogast, L. P. Waits, J. P. Dumbacher, S. J. Stepan, and R. K. Wayne, and valuable editorial advice from R. Waples and R. Morgenweck, further improved the manuscript. Comments from peer reviewers and the Subject Editor for *North American Fauna* provided valuable guidance in our preparation of the final manuscript. V. Martinez assisted with literature searches and editing, and M. Dick with preparation of the map. A. Post and A. White at the Conservation Library, National Conservation Training Center, located several rare references. J. Leonard provided specific locality data and DNA sequences for specimens reported in the literature.

Any use of trade, product, or firm names is for descriptive purposes only and does not imply endorsement by the U.S. Government.

References

- Adams JR, Kelly BT, Waits LP. 2003. Using faecal DNA sampling and GIS to monitor hybridization between red wolves (*Canis rufus*) and coyotes (*Canis latrans*). *Molecular Ecology* 12:2175–2186.
- Allen GM, Barbour T. 1937. The Newfoundland wolf. *Journal of Mammalogy* 18:229–234.
- American Ornithologists' Union. 1983. Check-list of North American birds. Washington, D.C.: American Ornithologists' Union.
- Anderson TM, vonHoldt BM, Candille SI, Musiani M, Greco C, Stahler DR, Smith DW, Padhukasahasram B, Randi E, Leonard JA, Bustamante CD, Ostrander EA, Tang H, Wayne RK, Barsh GS. 2009. Molecular and evolutionary history of melanism in North American gray wolves. *Science* 323:1339–1343.
- Avise JC. 2004. Molecular markers, natural history, and evolution. 2nd edition. Sunderland, Massachusetts: Sinauer.
- Avise JC, Ball RM Jr. 1990. Principles of genealogical concordance in species concepts and biological taxonomy. *Oxford Surveys in Evolutionary Biology* 7:45–67.
- Avise JC, Walker D, Johns GC. 1998. Speciation durations and Pleistocene effects on vertebrate phylogeography. *Proceedings of the Royal Society B* 265:1707–1712.
- Bailey V. 1936. The mammals and life zones of Oregon. Washington, D.C.: U.S. Government Printing Office. North American Fauna No. 55.
- Baker RJ, Bradley LC, Bradley RD, Dragoo JW, Engstrom MD, Hoffman FS, Jones CA, Reid F, Rice DW, Jones C. 2003. Revised checklist of North American mammals north of Mexico. Lubbock, Texas: Museum of Texas Tech University. Occasional Papers No. 229.
- Ballard WB, Carbyn LN, Smith DW. 2003. Wolf interactions with non-prey. Pages 259–271 in Mech LD, Boitani L, editors. *Wolves: behavior, ecology, and conservation*. Chicago: University of Chicago Press.
- Bannasch DL, Bannasch MJ, Ryun JR, Famula TR, Pederson NC. 2005. Y chromosome haplotype analysis in purebred dogs. *Mammalian Genome* 16:273–280.
- Barsh GS, Anderson TM, vonHoldt BM, Candille SI, Musiani M, Stahler DR, Leonard JA, Padhukasahasram B, Randi E, Bustamante CD, Ostrander EA, Tang H, Wayne RK. 2009. Response [to Rutledge et al. 2009]. *Science* 325:34.
- Bartram W. 1791. Travels through North and South Carolina, Georgia, East and West Florida, the Cherokee Country, the extensive territories of the muscogulges, or Creek Confederacy, and the Country of the Chactaws. Republished as *Travels of William Bartram*, Van Doren M, editor. 1955. New York: Dover Publications.
- Bekoff M. 1977. *Canis latrans*. *Mammalian Species* 70:1–9.
- Bertorelle G, Excoffier L. 1998. Inferring admixture proportions from molecular data. *Molecular Biology and Evolution* 15: 1298–1311.
- Bogan MA, Mehlhop P. 1983. Systematic relationships of gray wolves (*Canis lupus*) in southwestern North America. Albuquerque, New Mexico: Museum of Southwestern Biology, University of New Mexico. Occasional Papers No. 1.
- Bowen BW, Karl SA. 1999. In war, truth is the first casualty. *Conservation Biology* 13:1013–1016.
- Boyko AR, Quignon P, Li L, Schoenebeck J, Degenhardt JD, Lohmueller KE, Zhao K, Brisbin A, Parker HG, vonHoldt BM, Cargill M, Auton A, Reynolds A, Elkhahloun AG, Castelhan M, Mosher DS, Sutter NB, Johnson GS, Novembre J, Hubisz MJ, Siepel A, Wayne RK, Bustamante CD, Ostrander EA. 2010. A simple genetic architecture underlies morphological variation in dogs. *PLoS Biology* 8:e1000451.
- Brewster WG, Fritts SH. 1995. Taxonomy and genetics of the gray wolf in western North America: a review. Pages 353–373 in Carbyn LN, Fritts SH, Seip DR, editors. *Proceedings of the second North American symposium on wolves*. Edmonton, Alberta: Canadian Circumpolar Institute, University of Alberta.
- Carmichael LE, Krizan J, Nagy JA, Dumond M, Johnson D, Veitch A, Strobeck C. 2008. Northwest passages: conservation genetics of Arctic island wolves. *Conservation Genetics* 9:879–892.
- Carmichael LE, Krizan J, Nagy JA, Fuglei E, Dumond M, Johnson D, Veitch A, Berteaux D, Strobeck C. 2007. Historical and ecological determinants of genetic structure in arctic canids. *Molecular Ecology* 16:3466–3483.
- Carmichael LE, Nagy JA, Larter NC, Strobeck C. 2001. Prey specialization may influence patterns of gene flow in wolves of the Canadian Northwest. *Molecular Ecology* 10:2787–2798.
- Carroll C. 2003. Impacts of landscape change on wolf viability in the northeastern U.S. and southeastern Canada; implications for wolf recovery. Richmond, Vermont: Wildlands Project. Wildlands Project Special Paper 5.
- Carroll C, Phillips MK, Lopez-Gonzales CA, Schumaker NH. 2006. Defining recovery goals and strategies for endangered species: the wolf as a case study. *BioScience* 56:25–37.
- Carroll C, Phillips MK, Schumaker NH, Smith DW. 2003. Impacts of landscape change on wolf restoration success: planning a reintroduction program based on static and dynamic models. *Conservation Biology* 17:536–548.
- Cathey JC, Bickham JW, Patton JC. 1998. Introgressive hybridization and non-concordant evolutionary history of maternal and paternal lineages in North American deer. *Evolution* 52: 1224–1229.
- Coyne JA, Orr HA. 2004. Speciation. Sunderland, Massachusetts: Sinauer.
- Cronin MA, Mech DL. 2009. Problems with the claim of ecotype and taxon status of the wolf in the Great Lakes region. *Molecular Ecology* 18:4991–4993.
- Currat M, Ruedi M, Petit RJ, Excoffier L. 2008. The hidden side of invasions: massive introgression by local genes. *Evolution* 62: 1908–1920.
- Darimont CT, Paquet PC, Reimchen TE. 2008. Spawning salmon disrupt trophic coupling between wolves and ungulate prey in coastal British Columbia. *BMC Ecology* 8:14.
- Darimont CT, Reimchen TE, Paquet PC. 2003. Foraging behavior by gray wolves on salmon streams in coastal British Columbia. *Canadian Journal of Zoology* 81:349–353.



- Dawes PR, Elander M, Ericson M. 1986. The wolf (*Canis lupus*) in Greenland: a historical review and present status. *Arctic* 39: 119–132.
- de Queiroz K. 2007. Species concepts and species delimitation. *Systematic Biology* 56:879–886.
- [ESA] U.S. Endangered Species Act of 1973, as amended, Pub. L. No. 93-205, 87 Stat. 884 (Dec. 28, 1973). Available: <http://www.fws.gov/endangered/esa-library/pdf/ESAaall.pdf>.
- Excoffier L, Smouse PE, Quattro JM. 1992. Analysis of molecular variance inferred from metric distances among DNA haplotypes: application to human mitochondrial DNA restriction data. *Genetics* 131:479–491.
- Fain SR, Straughan DJ, Taylor BF. 2010. Genetic outcomes of eastern timber wolf recovery in the western Great Lakes States. *Conservation Genetics* 11:1747–1765.
- Feng J, Lajia C, Taylor DJ, Webster MS. 2001. Genetic distinctiveness of endangered dwarf blue sheep (*Pseudois nayaur schaeferi*): evidence from mitochondrial control region and Y-linked intron sequences. *Journal of Heredity* 92:9–15.
- Fitzpatrick BM, Johnson JR, Kump DK, Shaffer HB, Smith JJ, Voss SR. 2009. Rapid fixation of non-native alleles revealed by genome-wide SNP analysis of hybrid tiger salamanders. *BMC Evolutionary Biology* 9:176. doi: 10.1186/1471-2148-9-176.
- Forbes SH, Boyd DK. 1996. Genetic variation of naturally colonizing wolves in the central Rocky Mountains. *Conservation Biology* 10:1082–1090.
- Forbes SH, Boyd DK. 1997. Genetic structure and migration in native and reintroduced Rocky Mountain wolf populations. *Conservation Biology* 10:1226–1234.
- García-Moreno J, Matocq MD, Roy RS, Geffen E, Wayne RK. 1996. Relationships and genetic purity of the endangered Mexican wolf based on analysis of microsatellite loci. *Conservation Biology* 10:376–389.
- Goldman EA. 1937. The wolves of North America. *Journal of Mammalogy* 18:37–45.
- Goldman EA. 1944. Classification of wolves: part II. Pages 389–636 in Young SP, Goldman EA, editors. *The wolves of North America*. Washington, D.C.: The American Wildlife Institute.
- Goldstein PZ, DeSalle R, Amato G, Vogler AP. 2000. Conservation genetics at the species boundary. *Conservation Biology* 14: 120–131.
- Grant PR, Grant BR. 1992. Hybridization of bird species. *Science* 256:193–197.
- Grant PR, Grant BR. 2006. Species before speciation is complete? *Annals of the Missouri Botanical Garden* 93:94–102.
- Gray MM, Granka JM, Bustamante CD, Sutter NB, Boyko AR, Zuh L, Ostrander EA, Wayne RK. 2009. Linkage disequilibrium and demographic history of wild and domestic canids. *Genetics* 181:1493–1505.
- Grewal SK, Wilson PJ, Kung TK, Shami K, Theberge MT, Theberge JB, White BN. 2004. A genetic assessment of the eastern wolf (*Canis lycaon*) in Algonquin Provincial Park. *Journal of Mammalogy* 85:625–632.
- Hailer F, Leonard JA. 2008. Hybridization among three native North American *Canis* species in a region of natural sympatry. *Public Library of Science ONE* 3(10):e333. doi: 10.1371/journal.pone.0003333.
- Hall ER. 1981. *The mammals of North America*. 2nd edition. Volume II. New York: Wiley.
- Hall ER, Kelson KR. 1952. Comments on the taxonomy and geographic distribution of some North American marsupials, insectivores and carnivores. *University of Kansas Publications, Museum of Natural History* 5:319–341.
- Hall ER, Kelson KR. 1959. *The mammals of North America*. Volume II. New York: Ronald Press.
- Hanotte O, Tawah CL, Bradley DG, Okomo M, Verjee Y, Ochieng J, Rege JEO. 2000. Geographic distribution and frequency of a taurine *Bos taurus* and an indicine *Bos indicus* Y specific allele amongst sub-Saharan African cattle breeds. *Molecular Ecology* 9:387–396.
- Hedrick PW, Lee RN, Garrigan D. 2002. Major histocompatibility complex variation in red wolves: evidence for common ancestry with coyotes and balancing selection. *Molecular Ecology* 11: 1905–1913.
- Hedrick PW, Lee RN, Parker KM. 2000. Major histocompatibility complex (MHC) variation in the endangered Mexican wolf and related canids. *Heredity* 85:617–624.
- Hedrick PW, Miller PS, Geffen E, Wayne RK. 1997. Genetic evaluation of the three captive Mexican wolf lineages. *Zoo Biology* 16:47–69.
- Helyar SJ, Hemmer-Hanson J, Bekkevold D, Taylor MI, Ogden R, Limborg MT, Cariani A, Maes GE, Diopere E, Carvalho GR, Nielsen EE. 2011. Application of SNPs for population genetics of nonmodel organisms: new opportunities and challenges. *Molecular Ecology Resources* 11(Supplement 1):123–136.
- Hendry AP. 2009. Speciation. *Nature* 458:162–164.
- Hubbard JK, Uy AC, Hauber ME, Hoekstra HE, Safran RJ. 2010. Vertebrate pigmentation: from underlying genes to adaptive function. *Trends in Genetics* 26:231–239.
- International Commission on Zoological Nomenclature. 1999. *International code for zoological nomenclature*. 4th edition. London: The International Trust for Zoological Nomenclature. Available: <http://www.iczn.org/iczn/index.jsp> (June 23).
- James FC, McCulloch CE. 1990. Multivariate analysis in ecology and systematics: panacea or Pandora's box? *Annual Review of Ecology and Systematics* 21:129–166.
- Jolicoeur P. 1959. Multivariate geographical variation in the wolf *Canis lupus* L. *Evolution* 13:283–299.
- Kalinowski ST. 2011. The computer program STRUCTURE does not reliably identify the main genetic clusters within species: simulations and implication for human population structure. *Heredity* 106:625–632.
- Kays R, Curtis A, Kirchman JJ. 2009. Rapid adaptive evolution of northeastern coyotes via hybridization with wolves. *Biology Letters* 6:89–93.
- Kennedy LJ, Angles JM, Barnes A, Carmichael LE, Radford AD, Ollier WER, Happ GM. 2007. DLA-DRB1, DQA1, and DQB1 alleles and haplotypes in North American gray wolves. *Journal of Heredity* 98:491–499.
- Klein J. 1987. Origin of major histocompatibility complex polymorphism: the trans-species hypothesis. *Human Immunology* 19:155–162.
- Koblmüller S, Nord M, Wayne RK, Leonard JA. 2009a. Origin and status of the Great Lakes wolf. *Molecular Ecology* 18: 2313–2326.
- Koblmüller S, Nord M, Wayne RK, Leonard JA. 2009b. More is better. *Molecular Ecology* 18:4991–4993.
- Kolenosky GB, Standfield RO. 1975. Morphological and ecological variation among gray wolves (*Canis lupus*) of Ontario, Canada. Pages 62–72 in Fox MW, editor. *The wild canids; their systematic, behavioral ecology and evolution*. New York: Van Nostrand Reinhold.
- Kurtén B, Anderson E. 1980. *Pleistocene mammals of North America*. New York: Columbia University Press.
- Kyle CJ, Johnson AR, Patterson BR, Wilson PJ, White BN. 2008. The conspecific nature of eastern and red wolves: conservation and management implications. *Conservation Genetics* 9:699–701.
- Lance RF, Kennedy ML, Leberg PL. 2000. Classification bias in discriminant function analyses used to evaluate putatively different taxa. *Journal of Mammalogy* 81:245–249.
- Lawrence B, Bossert WH. 1967. Multiple character analysis of *Canis lupus*, *latrans*, and *familiaris*, with a discussion of the relationships of *Canis niger*. *American Zoologist* 7:223–232.
- Lehman N, Eisenhauer A, Hansen K, Mech LD, Peterson RO, Gogan PJP, Wayne RK. 1991. Intgression of coyote mitochondrial DNA into sympatric North American gray wolf populations. *Evolution* 45:104–119.
- Leonard JA, Vilà C, Fox-Dobbs K, Koch PL, Wayne RK, Van Valkenburgh G. 2007. Megafaunal extinctions and the disappearance of a specialized wolf ecomorph. *Current Biology* 17:1146–1150.
- Leonard JA, Vilà C, Wayne RK. 2005. Legacy lost: genetic variability and population size of extirpated US Grey wolves (*Canis lupus*). *Molecular Ecology* 14:9–17.
- Leonard JA, Wayne RK. 2008. Great Lakes wolves were not restored. *Biology Letters* 4:95–98.
- Leonard JA, Wayne RK, Wheeler J, Valadez R, Guillén S, Vilà C. 2002. Ancient DNA evidence for Old World origin of New World dogs. *Science* 298:1613–1616.
- Maldonado JE, Hertel F, Vilà C. 2004. Discordant patterns of morphological variation in genetically divergent populations of ornate shrews (*Sorex ornatus*). *Journal of Mammalogy* 85: 886–896.

- Mank JE, Carson JE, Brittingham MC. 2004. A century of hybridization: decreasing genetic distance between American black ducks and mallards. *Conservation Genetics* 5:395–403.
- Mayr E. 1942. *Systematics and the origin of species*. New York: Columbia University Press.
- Mayr E. 1963. *Animal species and evolution*. Cambridge, Massachusetts: Belknap Press.
- Mayr E. 1969. *Principles of systematic zoology*. New York: McGraw-Hill.
- Mayr E. 1970. *Populations, species, and evolution*. Cambridge, Massachusetts: Belknap Press.
- McCracken KG, Johnson WP, Sheldon FH. 2001. Molecular population genetics, phylogeography, and conservation biology of the mottled duck (*Anas fulvigula*). *Conservation Genetics* 2: 87–102.
- McKay BD, Zink RM. 2010. The causes of mitochondrial DNA gene tree paraphyly in birds. *Molecular Phylogenetics and Evolution* 54:647–650.
- Mech LD. 1974. *Canis lupus*. *Mammalian Species* 37:1–6.
- Mech LD. 1987. Age, season, distance, direction, and social aspects of wolf dispersal from a Minnesota pack. Pages 55–74 in Chepko-Sade BD, Halpin ZT, editors. *Mammalian dispersal patterns*. Chicago: University of Chicago Press.
- Mech LD. 2010. What is the taxonomic identity of Minnesota wolves? *Canadian Journal of Zoology* 88:129–138.
- Mech LD, Boitani L, editors. 2003. *Wolves: behavior, ecology, and conservation*. Chicago: University of Chicago Press.
- Mech LD, Frenzel LD. 1971. The possible occurrence of the Great Plains wolf in northeastern Minnesota. Pages 60–62 in Mech LD, Frenzel LD, editors. *Ecological studies of the timber wolf in northeastern Minnesota*. Saint Paul, Minnesota: North Central Forest Experiment Station.
- Mech LD, Nowak RM, Weisberg S. 2011. Use of cranial characters in taxonomy of the Minnesota wolf (*Canis* sp.). *Canadian Journal of Zoology* 89:1188–1194.
- Mech LD, Paul WJ. 2008. Wolf body mass cline across Minnesota related to taxonomy? *Canadian Journal of Zoology* 86:933–936.
- Merkle JA, Krausman PR, Stark DW, Oakleaf JK, Ballard WB. 2009. Summer diet of the Mexican gray wolf (*Canis lupus baileyi*). *The Southwestern Naturalist* 54:480–485.
- Miller GS Jr. 1912. *The names of large wolves of northern and western North America*. Washington, D.C.: Smithsonian Miscellaneous Collections 59(15).
- Moritz C. 1994. Defining evolutionarily significant units for conservation. *Trends in Ecology and Evolution* 9:373–375.
- Mulders R. 1997. *Geographic variation in the cranial morphology of the wolf (Canis lupus) in northern Canada*. Master's thesis. Sudbury, Ontario: Laurentian University.
- Muñoz-Fuentes V, Darimont CT, Paquet PC, Leonard JA. 2010. The genetic legacy of extirpation and re-colonization in Vancouver Island Wolves. *Conservation Genetics* 11:547–556.
- Muñoz-Fuentes V, Darimont CT, Wayne RK, Paquet PC, Leonard JA. 2009. Ecological factors drive differentiation in wolves from British Columbia. *Journal of Biogeography* 36: 1516–1531.
- Musiani M, Leonard JA, Cluff HD, Gates CC, Mariani S, Paquet PC, Vila C, Wayne RK. 2007. Differentiation of tundra/taiga and boreal coniferous forest wolves: genetics, coat colour and association with migratory caribou. *Molecular Ecology* 16: 4149–4170.
- Nei M. 1972. Genetic distance between populations. *American Naturalist* 106:283–292.
- Nei M. 1978. Estimation of average heterozygosity and genetic distance from a small number of individuals. *Genetics* 89:583–590.
- Nelson EW, Goldman EA. 1929. A new wolf from Mexico. *Journal of Mammalogy* 10:165–166.
- Nevado B, Koblmueller SL, Sturmbauer C, Snoeks J, Usano-Alemayn J, Verheyen E. 2009. Complete mitochondrial DNA replacement in a Lake Tanganyika cichlid fish. *Molecular Ecology* 18:4240–4255.
- Nowak RM. 1979. *North American Quaternary Canis*. Monograph of the Museum of Natural History, University of Kansas 6:1–154.
- Nowak RM. 1983. A perspective on the taxonomy of wolves in North America. Pages 10–19 in Carbyn LN, editor. *Wolves in Canada and Alaska: their status, biology, and management*. Edmonton, Alberta: Canadian Wildlife Service.
- Nowak RM. 1995. Another look at wolf taxonomy. Pages 375–397 in Carbyn LN, Fritts SH, Seip DR, editors. *Proceedings of the second North American symposium on wolves*. Edmonton, Alberta: Canadian Circumpolar Institute, University of Alberta.
- Nowak RM. 2002. The original status of wolves in eastern North America. *Southeastern Naturalist* 1:95–130.
- Nowak RM. 2003. *Wolf evolution and taxonomy*. Pages 239–258 in Mech LD, Boitani L, editors. *Wolves, behavior, ecology, and conservation*. Chicago: University of Chicago Press.
- Nowak RM. 2009. *Taxonomy, morphology, and genetics of wolves in the Great Lakes region*. Pages 233–250 in Wydeven AP, Van Deelen TR, Heske E, editors. *Recovery of wolves in the Great Lakes region*. New York: Springer.
- Oakleaf JK, Murray DL, Oakleaf JR, Bangs EE, Mack CM, Smith DW, Fontaine JA, Jendryk MD, Meier TJ, Niemeyer CC. 2006. Habitat selection by recolonizing wolves in the northern Rocky Mountains of the United States. *Journal of Wildlife Management* 70:554–563.
- Olivier M, Breen M, Binns MM, Lust G. 1999. Localization and characterization of nucleotide sequences from the canine Y chromosome. *Chromosome Research* 7:223–233.
- Olivier M, Lust G. 1998. Two new nucleotide sequences specific for the canine Y chromosome. *Animal Genetics* 29:146–149.
- Paetkau D, Waits LP, Clarkson PL, Craighead L, Strobeck C. 1997. An empirical evaluation of genetic distance statistics using microsatellite data from bear (*Ursidae*) populations. *Genetics* 147:1943–1957.
- Paradiso JL, Nowak RM. 1972. *Canis rufus*. *Mammalian Species* 22: 104.
- Parsons D. 1996. Case study: the Mexican wolf. Pages 101–123 in Herrera EA, Huenneke LF, editors. *New Mexico's natural heritage: biological diversity in the land of enchantment*. Albuquerque, New Mexico: New Mexico Academy of Science. New Mexico Journal of Science, Volume 36.
- Patten MA, Unit P. 2002. Diagnosability versus mean differences of sage sparrow subspecies. *The Auk* 119:26–35.
- Phillips MK, Henry VG, Kelly BT. 2003. Restoration of the red wolf. Pages 272–288 in Mech LD, Boitani L, editors. *Wolves: behavior, ecology, and conservation*. Chicago: University of Chicago Press.
- Pidancier N, Jordan S, Luikart G, Taberlet P. 2006. Evolutionary history of the genus *Capra* (Mammalia, Artiodactyla): discordance between mitochondrial DNA and Y-chromosome phylogenies. *Molecular Phylogenetics and Evolution* 40: 739–749.
- Pilot M, Jedrzewski W, Branicki W, Sidorovich VE, Jedrzewski B, Stachura K, Funk SM. 2006. Ecological factors influence population genetic structure of European grey wolves. *Molecular Ecology* 15:4533–4553.
- Pocock RI. 1935. The races of *Canis lupus*. *Proceedings of the Zoological Society, London*, Part 3:647–686.
- Pritchard JK, Stephens M, Donnelly P. 2000. Inference of population structure using multilocus genotype data. *Genetics* 155:945–959.
- Reed JE, Ballard WB, Gipson PS, Kelly BT, Krausman PR, Wallace MC, Webster DB. 2006. Diets of free-ranging Mexican gray wolves in Arizona and New Mexico. *Wildlife Society Bulletin* 34:1127–1133.
- Reich DE, Wayne RK, Goldstein DB. 1999. Genetic evidence for a recent origin by hybridization of red wolves. *Molecular Ecology* 8:139–144.
- Richardson J. 1829. *Fauna Boreali-Americana, Part 1*. London: John Murray.
- Roy MS, Geffen E, Ostrander D, Wayne RK. 1994. Patterns of differentiation and hybridization in North American wolflike canids, revealed by analysis of microsatellite loci. *Molecular Biology and Evolution* 11:533–570.
- Roy MS, Geffen E, Smith E, Wayne RK. 1996. Molecular genetics of pre-1940 red wolves. *Conservation Biology* 10: 1413–1424.
- Rutledge LY, Bos KJ, Pearce RJ, White BN. 2010a. Genetic and morphometric analysis of sixteenth century *Canis* skull fragments: implication for historic eastern and gray wolf

- distribution in North America. *Conservation Genetics* 11: 1273–1281.
- Rutledge LY, Garroway CJ, Loveless KM, Patterson BR. 2010b. Genetic differentiation of eastern wolves in Algonquin Park despite bridging gene flow between coyotes and grey wolves. *Heredity* 105:520–531.
- Rutledge LY, Patterson BR, White BN. 2010c. Analysis of *Canis* mitochondrial DNA demonstrates high concordance between the control region and ATPase genes. *BMC Evolutionary Biology* 10:25.
- Rutledge LY, Wilson PJ, Klütsch FC, Patterson BR, White BN. 2012. Conservation genomics in perspective: A holistic approach to understanding *Canis* evolution in North America. *Biological Conservation* 155:186–192.
- Rutledge LY, Wilson PJ, Kyle CJ, Wheeldon TJ, Patterson BR, White BN. 2009. How the gray wolf got its color. *Science* 325: 33–34.
- Say T. 1823. Pages 167–199 in Long SH. Account of an expedition from Pittsburgh to the Rocky Mountains performed in the years 1819 and 1820. Volume I. Philadelphia: Carey and Lea.
- Schmitz OJ, Kolenosky GB. 1985. Wolves and coyotes in Ontario: morphological relationships and origins. *Canadian Journal of Zoology* 63:1130–1137.
- Schreber JCD. 1775. Die Säugethiere in abbildungen nach der Natur mit beschreibungen, Teile 2. Erlangen, Bavaria.
- Schwartz MK, McKelvey KS. 2009. Why sampling scheme matters: the effect of sampling scheme on landscape genetic results. *Conservation Genetics* 10:441–452.
- Schwartz MK, Pilgrim KL, McKelvey KS, Lindquist EL, Claar JJ, Loch S, Ruggiero LF. 2004. Hybridization between Canada lynx and bobcats: genetic results and management implications. *Conservation Genetics* 5:349–355.
- Schwartz MK, Vucetich JA. 2009. Molecules and beyond: assessing the distinctness of the Great Lakes wolf. *Molecular Ecology* 18: 2307–2309.
- Schwenk K, Brede N, Streit B. 2008. Introduction. Extent, processes and evolutionary impact of interspecific hybridization in animals. *Philosophical Transactions of the Royal Society B* 363:2805–2811.
- Seehausen O. 2006. Conservation: losing biodiversity by reverse speciation. *Current Biology* 16(9):R334.
- Seehausen O, van Alphen JJM, Witte F. 1997. Cichlid fish diversity threatened by eutrophication that curbs sexual selection. *Science* 277:1808–1811.
- Shami K. 2002. Evaluating the change in distribution of the eastern timber wolf (*Canis lycaon*) using the Y-chromosome. Master's thesis. Hamilton, Ontario: McMaster University.
- Sites JW Jr, Marshall JC. 2004. Operational criteria for delimiting species. *Annual Review of Ecology and Systematics* 35:199–227.
- Skeel MA, Carbyn L. 1977. The morphological relationship of gray wolves (*Canis lupus*) in national parks of central Canada. *Canadian Journal of Zoology* 55:737–747.
- Slatkin M. 1985. Rare alleles as indicators of gene flow. *Evolution* 39:53–65.
- Standfield R. 1970. Some considerations on the taxonomy of wolves in Ontario. Pages 32–38 in Jorgensen SE, Faulkner CE, Mech LD, editors. Proceedings of a symposium on wolf management in selected areas of North America. Twin Cities, Minnesota: U.S. Bureau of Sport Fisheries and Wildlife.
- Stronen AV, Forbes GJ, Sallows T, Goulet G, Musiani M, Paquet PC. 2010. Wolf body mass, skull morphology, and mitochondrial DNA haplotypes in the Riding Mountain National Park Region of Manitoba, Canada. *Canadian Journal of Zoology* 88:496–507.
- Sundqvist A-K, Björnerfeldt S, Leonard JA, Hailer F, Heldhammar Å, Ellegren H, Vilà C. 2006. Unequal contribution of sexes in the origin of dog breeds. *Genetics* 172:1121–1128.
- Sundqvist A-K, Ellegren H, Olivier M, Vilà C. 2001. Y chromosome haplotyping in Scandinavian wolves (*Canis lupus*) based on microsatellite markers. *Molecular Ecology* 10:1959–1966.
- Tang H, Coram M, Wang P, Zhu X, Risch N. 2006. Reconstructing genetic ancestry blocks in admixed individuals. *American Journal of Human Genetics* 79:1–12.
- Templeton AR. 1989. The meaning of species and speciation: a genetic perspective. Pages 3–27 in Otte D, Endler JA, editors. Speciation and its consequences. Sunderland, Massachusetts: Sinauer Associates.
- Theberge JB, Theberge MT. 2004. The wolves of Algonquin Park: a 12 year ecological study. Waterloo, Ontario: University of Waterloo. Department of Geography, Publication Series No. 56.
- [USFWS] U.S. Fish and Wildlife Service. 1990. Red wolf recovery/species survival plan. Atlanta: U.S. Fish and Wildlife Service.
- [USFWS and NOAA] U.S. Fish and Wildlife Service and National Oceanic and Atmospheric Administration. 1995. Policy regarding the recognition of distinct vertebrate population segments under the Endangered Species Act. Federal Register 61:4722–4725.
- Vilà C, Amorim IR, Leonard JA, Posada D, Catrović J, Petrucci-Fonseca F, Crandall KA, Ellegren H, Wayne RK. 1999. Mitochondrial DNA phylogeography and population history of the grey wolf *Canis lupus*. *Molecular Ecology* 8:2089–2103.
- Vilà C, Savolainen P, Maldonado JE, Amorim IR, Rice JE, Honeycutt RL, Crandall KA, Lundeberg J, Wayne RK. 1997. Multiple and ancient origins of the domestic dog. *Science* 276:1687–1689.
- vonHoldt BM, Pollinger JP, Earl DA, Knowles JC, Boyko AR, Parker H, Geffen E, Pilot M, Jedrzejewski W, Jedrzejewski B, Sidorovich V, Creco C, Ettore R, Musiani M, Kays R, Bustamante CD, Ostrander EA, Novembre J, Wayne RK. 2011. A genome-wide perspective on the evolutionary history of enigmatic wolf-like canids. *Genome Research* 21:1294–1305.
- vonHoldt BM, Stahler DR, Banks EE, Smith DW, Jimenez MD, Mack CM, Niemeyer CC, Pollinger JP, Wayne RK. 2010. A novel assessment of population structure and gene flow in grey wolf populations of the Northern Rocky Mountains of the United States. *Molecular Ecology* 19:4412–4427.
- vonHoldt BM, Stahler DR, Smith DW, Earl DA, Pollinger JP, Wayne RK. 2008. The genealogy and genetic viability of reintroduced Yellowstone grey wolves. *Molecular Ecology* 17: 252–274.
- Wayne RK, Jenks SM. 1991. Mitochondrial DNA analysis implying extensive hybridization of the endangered red wolf *Canis rufus*. *Nature* 351:565–568.
- Wayne RK, Lehman N, Allard MW, Honeycutt RL. 1992. Mitochondrial DNA variability of the gray wolf: genetic consequences of population decline and habitat fragmentation. *Conservation Biology* 6:559–569.
- Wayne RK, Lehman N, Fuller TK. 1995. Conservation genetics of the gray wolf. Pages 399–407 in Carbyn LN, Fritts SH, Scip DR, editors. Proceedings of the second North American symposium on wolves. Edmonton, Alberta: Canadian Circumpolar Institute, University of Alberta.
- Wayne RK, Vilà C. 2003. Molecular genetic studies of wolves. Pages 218–238 in Mech LD, Boitani L, editors. Wolves: behavior, ecology, and conservation. Chicago: University of Chicago Press.
- Weckworth BV, Dawson NG, Talbot SL, Flamme MJ, Cook JA. 2011. Going coastal: evolutionary history between coastal British Columbia and southeast Alaska wolves (*Canis lupus*). *PLoS One* 6(5):e19582. doi: 10.1371/journal.pone.0019582.
- Weckworth BV, Talbot SL, Cook JA. 2010. Phylogeography of wolves (*Canis lupus*) in the Pacific Northwest. *Journal of Mammalogy* 91:363–375.
- Weckworth BV, Talbot S, Sage GK, Person DK, Cook J. 2005. A signal for independent coastal and continental histories among North American wolves. *Molecular Ecology* 14:917–931.
- Weir BS, Cockerham CC. 1984. Estimating *F* statistics for the analysis of population structure. *Evolution* 38:1358–1370.
- Wheeldon T. 2009. Genetic characterization of *Canis* population in the western Great Lakes region. Master's thesis. Peterborough, Ontario: Trent University.
- Wheeldon T, Patterson BR, White BN. 2010. Sympatric wolf and coyote populations of the western Great Lakes region are reproductively isolated. *Molecular Ecology* 19:4428–4440.
- Wheeldon T, White BM. 2009. Genetic analysis of historical western Great Lakes region wolf samples reveals early *Canis lupus/lycaon* hybridization. *Biology Letters* 5:101–104.

- Wiley EO. 1981. *Phylogenetics; the theory and practice of phylogenetic systematics*. New York: Wiley.
- Wilson DE, Reeder DM, editors. 2005. *Mammal species of the world; a taxonomic and geographic reference*. 3rd edition. Baltimore, Maryland: Johns Hopkins University Press.
- Wilson EO, Brown WL. 1953. The subspecies concept and its taxonomic application. *Systematic Zoology* 2:97–111.
- Wilson PJ, Grewal S, Lawford ID, Heal JNM, Granacki AG, Pennock D, Theberge JB, Theberge MT, Voigt DR, Waddell W, Chambers RE, Paquet PC, Goulet G, Cluff D, White BN. 2000. DNA profiles of the eastern Canadian wolf and the red wolf provide evidence for a common evolutionary history independent of the gray wolf. *Canadian Journal of Zoology* 78: 2156–2166.
- Wilson PJ, Grewal SK, Mallory FF, White BN. 2009. Genetic characterization of hybrid wolves across Ontario. *Journal of Heredity* 100:S80–S89.
- Wilson PJ, Grewal S, McFadden T, Chambers RC, White BN. 2003. Mitochondrial DNA extracted from eastern North American wolves killed in the 1800s is not of gray wolf origin. *Canadian Journal of Zoology* 81:936–940.
- Wright S. 1951. The genetical structure of populations. *Annals of Eugenics* 15:323–354.
- Young SP. 1944. Their history, habits, economic status and control. Pages 1–385 in Young SP, Goldman EA, editors. *The wolves of North America*. Washington, D.C.: The American Wildlife Institute.
- Zink RM. 2004. The role of subspecies in obscuring avian biological diversity and misleading conservation policy. *Proceedings of the Royal Society B* 271:561–564.

Appendix: Summaries of Taxonomically Relevant Information in Morphological and Genetic Studies

Studies of the morphology and genetics of North American *Canis* are summarized in the following sections, which are organized into categories by the type of data or genetic marker used. Each discussion of a category of information is followed by a brief summary of areas of agreement or disagreement among the studies. The species and subspecies names used in these summaries are those used by the authors of these papers; use of these names in these sections should not be interpreted as our acceptance of any author's nomenclature. Similarly, the conclusions stated in the summaries are those of the author(s) of each paper being summarized. Our analysis and conclusions are presented in the Analysis and Discussion section later in this paper.

Morphology

Nearly all recent studies of morphological variation among taxa of North American *Canis* employed the multivariate statistical methods of principal components analysis, discriminant function analysis, or both.

Jolicoeur (1959) carried out an analysis of the distribution of coat color and bivariate and multivariate discriminant function analyses of skull features of 499 *Canis lupus* from western Canada. Variation in pelage color is described in the next section on functional gene loci. Samples were grouped for the discriminant function analyses by

regions within Canadian provinces. He found general patterns of skulls trending from shorter and broader in the northeast to longer and narrower to the southeast portion of the study area. Although the study was not framed in a taxonomic context, he suggested that “far too many subspecific designations are now in use,” referring to the classification of Goldman (1944, p. 298). A notable result was that the samples from Vancouver Island were more like individuals from further north than like wolves on the neighboring mainland of British Columbia (Jolicoeur 1959, p. 297).

In a study of North American canids using discriminant function analysis, Lawrence and Bossert (1967) included a comparison of groups classified as “*Canis lupus*,” *Canis rufus* (under the name *Canis niger*), and *Canis lupus lycaon*. The *C. lupus* sample was found to be intermediate between *C. l. lycaon* (from Algonquin Provincial Park, Ontario) and *C. rufus*. The validity of this result is difficult to evaluate because the geographic source of the *C. lupus* sample of 20 wolves was not indicated and “large individuals were avoided” (p. 224), thus biasing the sample. Another factor limiting comparison to subsequent morphometric studies was the determination of character values relative to the length of the skull rather than actual measurements. This removed size as a character, and size is generally considered an important character in evaluating variation among wolves in North America (Kolenosky and Stanfield 1975; Nowak 1979; Schmitz and Kolenosky 1985).

Kolenosky and Standfield (1975) studied variation in skulls and body masses of two types of wolves from within the Ontario range of *C. l. lycaon* (as broadly defined by Goldman [1944]) using discriminant function analysis. Their accompanying analysis of these characters, as well as coat color, is described in the next section on functional gene loci. The samples included 105 “boreal-type” (from areas of boreal forests) wolves and 122 “Algonquin-type” wolves (from deciduous forest regions). Over 75% of boreal-type skulls could be distinguished from those of the Algonquin, or eastern wolf, type. Boreal males averaged 34.5 kg compared with 27.5 kg for Algonquin-type males. They suggested that the size and color of boreal-type individuals were more like *C. l. nubilus*, and that the two Ontario forms may not be interbreeding. They associated these types of wolves with different ungulate prey species; the larger boreal-type wolves presumably preyed on moose *Alces alces* and caribou *Rangifer* spp., and the Algonquin-type wolves presumably preyed on white-tailed deer.

Skeel and Carbyn (1977) performed principal components and discriminant function analyses on 311 wolf skulls from widely spaced localities in central and northern North America, including several Canadian national parks. Samples were

grouped by subspecies or by park for discriminant function analysis. For addressing the question of the relationship of *C. l. lycaon* to other *C. lupus*, the relevant samples were from the southwestern corner of Ontario (referred to as *C. l. lycaon*), historical *C. l. nubilus* (primarily from the north-central United States), *C. l. hudsonicus* from southeast Northwest Territories, and *C. l. griseoalbus* from Manitoba and Saskatchewan. The last two subspecies were later treated as synonyms of *C. l. nubilus* and *C. l. occidentalis*, respectively, in Nowak's (1995) taxonomic revision, which is discussed later. Strong geographic patterns were not obvious, except that *C. l. lycaon* is generally more similar to *C. l. nubilus* and its synonyms than to samples from further to the northwest, which would probably be attributable to *C. l. occidentalis* in Nowak's (1995) revised classification. Skeel and Carbyn's (1977) general conclusion was that there is large overlap in characters among individuals, but that wolves in "boreal-subalpine forest regions" are larger.

In comparing *C. l. occidentalis*, primarily from Canadian national parks, to other subspecies of *C. lupus*, three-dimensional principal components plots for males and females (Skeel and Carbyn 1977, figures 2 and 3, respectively) showed a clear separation of *C. l. occidentalis* (codes W, R, J, and P in the figures) from a grouping that included *C. l. nubilus*, *C. l. hudsonicus*, and *C. l. irremotus* (the latter two are synonyms of *C. l. nubilus* in Nowak's [1995] classification) samples on the first principal component, which can be attributed to the larger size of *C. l. occidentalis*. Discriminant function plots (Skeel and Carbyn 1977, figures 4 and 5) showed minimal overlap for polygons for *C. l. occidentalis* and *C. l. hudsonicus*, and more substantial overlap between *C. l. occidentalis* and both *C. l. nubilus* and *C. l. irremotus*. Further analysis with clustering (Skeel and Carbyn 1977, figure 6) showed discontinuity between *C. l. occidentalis* and the other subspecies, which grouped closer together. A multidimensional scaling analysis (Skeel and Carbyn 1977, figure 7) also separated *C. l. occidentalis* and *C. l. nubilus* samples, with the exception that Wood Buffalo National Park *C. l. occidentalis* were closest to *C. l. hudsonicus* from Northwest Territories on Hudson Bay; these are the two northern-most areas included in the study.

Nowak (1979) reviewed the taxonomic history and carried out discriminant function analyses of North American *Canis*. Groups for the initial analysis were gray wolf, red wolf, coyote, and domestic dog. Various samples that represented specific populations, time periods when specimens were collected, or extinct species of *Canis* were then plotted and compared with the positions of the samples from the initial analysis. Of particular relevance to the present review was his treatment of the relationships and

taxonomic standing of *C. rufus* and *C. l. lycaon*. Nowak (1979, p. 87) found little statistical overlap between early (before extensive introgression by coyotes *Canis latrans*) *C. rufus* ($n = 74$ males, 55 females) and western *C. lupus* ($n = 233$ males, 146 females) skulls, although a few specimens were difficult to assign. He noted (p. 29) that *C. rufus* resembled *C. l. lycaon* more than it did any other subspecies of *C. lupus*. Nowak (1979, figure 7) found substantial (but not complete) statistical overlap between skulls of *C. l. lycaon* and other *C. lupus* from western North America—*C. l. lycaon* individuals were generally smaller. Nor were the boreal-type (Ontario-type of Standfield [1970]) wolves of Ontario and the deciduous-type (Algonquin-type of Standfield [1970]) of southeastern Ontario and southern Quebec sharply delineated. Some characters in wolves from the western range of *C. l. lycaon* were found to be intermediate between the eastern *C. l. lycaon* and *C. l. nubilus* from the Great Plains (Nowak 1979, p. 20), thus lending some support to Mech and Frenzel's (1971) suggestion that some eastern Minnesota wolves were *C. l. nubilus*. Nowak's (1979, p. 21) general conclusion was that individuals that he referred to as *C. l. lycaon* were no more distinctive than other subspecies of *C. lupus*.

Nowak (1983, figure 6) performed a preliminary bivariate analysis of skulls of various subspecies of North American *C. lupus*, generally following Goldman's (1944) classification. The two studied characters generally reflect the length and width of skulls. This analysis indicated a cline in the two characters, with size increasing from south to north in central North America, but with a break or discontinuity at approximately the United States–Canada border in central North America that divided southern and northern *C. lupus*. Based on these data, he proposed new geographic groupings of North American wolves. In this scheme (Nowak 1983, figure 7b), wolves from Minnesota, Wisconsin, the Upper Peninsula of Michigan, and southwestern Ontario were grouped with southern wolves of the U.S. Great Plains to the west, rather than with *C. l. lycaon* as in Goldman (1944). The Hudson Bay sample (*C. l. hudsonicus*) was also grouped with the southern wolves. The sample of *C. l. columbianus* of far western Canada was intermediate but closer to the northern group. Skulls from the Canadian Arctic Islands (subspecies *C. l. arctos* and *C. l. bernardi*) were outliers to this general north–south trend in overall size and were distinguished by having skulls that were wide relative to their length. Nowak (1983, figure 7a, b) suggested that at the maximum extent of Pleistocene glaciations, the ancestors of *C. l. arctos* were isolated north of the ice sheet in a refugium in northern Greenland, and then spread westward to the Arctic Islands following withdrawal of the glaciers. He also

speculated that *C. l. bernardi* and *C. l. orion*, an Arctic subspecies from Greenland, may have declined and their former ranges occupied by *C. l. arctos*.

Based on this information and historical factors, Nowak (1983, figure 7a, b) suggested a “hypothetical” new evolutionary scenario and configuration of subspecies. At the maximum extent of Pleistocene glaciations, south of the ice sheet were wolves that had already evolved in or colonized North America: *C. l. lycaon* in the east, *C. l. baileyi* in the southwest, and a “southern group.” The southern group corresponds to *C. l. nubilus* in Nowak’s (1995) eventual reclassification. North of the ice sheet were the ancestors of *C. l. arctos* in the east, and a “northern group” isolated to the west in Alaska. This northern group corresponds to *C. l. occidentalis* in Nowak’s later revision.

Bogan and Mehlhop (1983) reported the results of principal component and discriminant function analyses of 253 wolf skulls from Mexico and the southwest region of the United States, including specimens from Kansas, Oklahoma, Texas, Colorado, New Mexico, and Arizona. Samples were grouped by subspecies according to Goldman’s (1944) classification. They considered *C. l. mogollonensis* and *C. l. monstabilis* to be synonyms of *C. l. baileyi* based on broad morphological overlap of their skulls (Bogan and Mehlhop 1983, figures 2 and 3; figure 2 is reproduced here as Figure 8). This effectively expanded the range of *C. l. baileyi* north to central Arizona and New Mexico, and east into central Texas. They also acknowledged that specimens previously referred to as *C. l. mogollonensis* represented intergrades between *C. l. baileyi* and *C. l. youngi* (the subspecies then recognized for the southern Rocky Mountains) and did not detect the abrupt break between *C. l. baileyi* and *C. l. mogollonensis* noted by Goldman (1944). They recognized three subspecies in the area covered by their study: *C. l. baileyi*, *C. l. youngi*, and in the Great Plains, *C. l. nubilus*.

Schmitz and Kolenosky (1985) reported clinal variation in *C. l. lycaon* (following Goldman’s [1944] delineation of the range of that subspecies) in Ontario based on discriminant function analysis of skull and body characters. Canids were assigned to six groups for the discriminant function analysis: boreal, Algonquin, and southern Ontario wolves; and Algonquin, southeast Ontario, and southwest Ontario coyotes. From larger wolves in boreal regions in the north, size declined to the smaller, Algonquin-type wolves in southern Ontario. They found that the boreal wolves more resembled Minnesota wolves than Algonquin wolves in body characters, but boreal more resembled Algonquin in skull characters. Their explanation was that the resemblance between boreal and Minnesota wolves (which they viewed as derived from *C. l. nubilus*) was owing to convergence based on similar prey size,

and that resemblance between boreal and Algonquin in skull characters was owing to taxonomic affinity and clinal variation within *C. l. lycaon*.

Nowak (1995) performed discriminant function analyses using 580 male skulls grouped by subspecies as delineated by Hall (1981), with *C. l. lycaon* further divided into three groups: Minnesota, western Ontario, and Algonquin Provincial Park. Based on statistical distances (D^2 of Mahalanobis), Nowak (1995, figure 20) revised the subspecies taxonomy of North American *C. lupus* in a manner generally consistent with the geographic groupings that he had proposed in his 1983 paper and reduced the number of subspecies from the 23 recognized by Goldman (1944) to 5. In this classification, most of the North American range of *C. lupus* is occupied by *C. occidentalis* and *C. nubilus*, which corresponded to the respective northern and southern groups identified earlier (Nowak 1983). The other three subspecies had smaller ranges on the periphery of the North American range of *C. lupus*: *C. l. lycaon* in the East, *C. l. baileyi* in the Southwest, and *C. l. arctos* in the islands of the High Arctic.

Nowak’s (1995) analysis included 105 individuals of *C. l. occidentalis* and 119 individuals of *C. l. nubilus*. An additional 46 specimens from subspecies that he included as synonyms of *C. l. nubilus* were also included in the study. Statistical distances and discriminant function plots (Nowak 1995, figures 5, 7; the latter is reproduced here as Figure 5) separate *C. l. nubilus* and *C. l. occidentalis*. Polygons on the discriminant function plots overlapped, but were mostly nonoverlapping, with *C. l. occidentalis* being larger than *C. l. nubilus*. *C. l. ligoni* (attributed by Nowak to *C. l. nubilus*) of coastal southeastern Alaska was intermediate. Nowak (1995, p. 383) acknowledged that *C. l. ligoni* has probably been affected by hybridization with *C. l. occidentalis*, but that it is partly isolated from *C. l. occidentalis* to the east by “mountains, glaciers, and waterways,” and has closer statistical distance to *C. l. nubilus* to the south. He also found that samples from coastal British Columbia, including Vancouver Island, were closer to *C. l. nubilus*.

Nowak (1995, p. 386, figure 10) found that *C. l. hudsonicus* (a synonym of *C. l. nubilus* in his classification), found west of Hudson Bay, was within the statistical limits of *C. l. nubilus*, although it overlapped with the discriminant function polygon for *C. l. occidentalis*. He suggested that Skeel and Carbyn’s (1977) finding that *C. l. hudsonicus* was closer to *C. l. occidentalis* from Wood Buffalo National Park may have involved inclusion of females, which are smaller, in the male sample of the latter. He also suggested that habitat and prey preferences may contribute to differences between *C. l. hudsonicus* and *C. l. occidentalis* and their coexistence without merging or displacement, stating that *C. l. occidentalis*

is mainly in the taiga in this area, while *C. l. hudsonicus* is mainly in the less productive tundra.

The range delineated for *C. l. lycaon* included southeastern Ontario and southern Quebec. Areas formerly considered by Goldman (1944) to be within the western range of *C. l. lycaon* (Minnesota, the Upper Peninsula of Michigan, Wisconsin, and southwestern Ontario) were included within the range of *C. l. nubilus*. Nowak (1995, figures 5, 10) based this on the low statistical distance between Minnesota wolves and historical *C. l. nubilus*, and on the occurrence of individuals from western Ontario within the range of variation of his southern group, which is equivalent to *C. l. nubilus*. *C. l. lycaon* from or near to Algonquin Provincial Park overlapped to some degree with the western Ontario specimens, but were mostly outside the polygon describing variation in *C. l. nubilus*.

Nowak (1995, figures 4, 8) recognized *C. l. baileyi* as a subspecies, but did not adopt Bogan and Mehlhop's (1983) inclusion of *C. l. mogollonensis* and *C. l. monstrabilis* as its synonyms. These different interpretations are discussed later in the Analysis and Discussion section under *C. l. baileyi*. The geographical ranges of *C. l. baileyi* and other subspecies of *C. lupus* may never have had definite or stationary boundaries. Nowak (1995, p. 385) suggested that *C. l. baileyi*, "regularly dispersed into the range of populations to the north and vice versa." He also suggested that extirpation of more northern wolves facilitated the dispersal of *C. l. baileyi* from Mexico to areas formerly occupied by other subspecies.

C. l. arctos partially overlapped both *C. l. nubilus* and *C. l. occidentalis* on Nowak's (1995, figure 9) discriminant function plot for some northern wolves. He recognized *C. l. arctos* as a subspecies based on these results, along with the observation that their large carnassial teeth were "the most consistent distinguishing character" (p. 386). He included *C. l. bernardi* in *C. l. arctos* based on this character, and included *C. l. orion* based on examination of two specimens and reported free movement (Dawes et al. 1986) of wolves between the northern Greenland range of *C. l. orion* and the Ellesmere Island portion of the range of *C. l. arctos*.

The relatively small size of *C. l. baileyi* and *C. l. lycaon* invites their comparison with *C. rufus*. Nowak's (1995) *C. rufus* sample was selected to exclude specimens that reflected hybridization with coyotes. These skulls were a series collected before 1930 in southern Missouri, and another collected before 1940 from southeastern Texas to Florida. They were compared with Algonquin Provincial Park *C. l. lycaon* from southeastern Canada and his "southern group" of gray wolves, which is equivalent to *C. l. nubilus* and includes Minnesota wolves collected after 1960. Nowak's (1995, figure 11) discriminant function analysis of these samples indicated that the areas of the discriminant function plot occupied by the

Algonquin *C. l. lycaon* and *C. rufus* individuals approach one another. He suggested the possibility that coyote hybridization could have contributed to the closeness of *C. l. lycaon* to *C. rufus*. He observed that there were too few specimens to evaluate whether *C. l. lycaon* and *C. rufus* intergraded. He described the historical range of *C. rufus* as extending north to Pennsylvania and that of *C. l. lycaon* as extending south from Quebec and Ontario "to an undetermined point in the eastern United States" (p. 396).

Nowak's (1995, figure 11) discriminant function analysis of *C. rufus* ($n = 33$) and *C. baileyi* ($n = 21$) showed no overlap, although one *C. baileyi* individual was just outside the polygon representing *C. rufus* individuals. Statistical distance values (Nowak 1995, figure 12) showed pronounced differences between 27 *C. l. monstrabilis* (a synonym of *C. l. baileyi* according to Bogan and Mehlhop [1983]) and *C. rufus*. Nowak (1995, p. 389) observed that, "there are no specimens to show that the gray wolf was sympatric with unmodified populations of red wolf," although *C. lupus* was in the vicinity of areas of central Texas where *C. rufus* and coyotes were hybridizing. In recent papers, Nowak (2002, 2003, 2009) repeated his view that *C. l. lycaon* is a subspecies of *C. lupus* and may be the result of hybridization that occurred when *C. rufus* advanced north into Canada following the last Pleistocene glacial retreat and came into contact with *C. lupus*, or more specifically the subspecies *C. l. nubilus*. His discriminant function plots showed that specimens attributed to *C. l. lycaon* ($n = 10$) are intermediate between western *C. lupus* ($n = 97$) and *C. rufus* ($n = 13$) and slightly overlap *C. lupus* (Nowak 2002, figure 8; 2003, figure 9.9).

In his review and discriminant function analysis of eastern *C. lupus* and *C. rufus*, Nowak (2002) explored relationships between *C. l. lycaon* and *C. l. rufus*, as well as *C. lupus* from the western Great Lakes region and some localities in the western United States. Historical *C. l. lycaon* ($n = 10$) specimens from southeastern Canada (Nowak 2002, figure 8) overlapped only slightly with a "western series" of *C. lupus* (ranging from Minnesota to Idaho and Arizona). A series from the Upper Peninsula of Michigan had substantial overlap with both the eastern *C. l. lycaon* and the western *C. lupus*. Based on the intermediacy of *C. l. lycaon* from southeastern Canada between *C. l. nubilus* and *C. rufus*, Nowak (2002, 2003) suggested that *C. l. lycaon* may be the result of hybridization as *C. l. nubilus* invaded from the west and encountered *C. rufus* invading from the south following retreat of the terminal Pleistocene glaciations. Nowak (2002, figure 6) compared Minnesota *C. lupus* skulls ($n = 23$) taken after 1970 with five series of historical specimens from within the western range of *C. l. nubilus* ($n = 78$). The Minnesota wolves overlapped strongly with the series

from the northern Rocky Mountains (of the United States), and less so with the southern Rocky Mountain series. There was slight overlap with the Nebraska–Kansas–Oklahoma series, and none with the small sample from Texas.

To determine whether western *C. lupus* and *C. rufus* became more morphologically similar where their ranges approach one another, Nowak (2002) performed a discriminant function analysis that included seven skulls from western Texas. These individuals were from within the range of *C. l. monstabilis*, which is considered a synonym of *C. l. baileyi* by Bogan and Mehlhop (1983), but is considered a synonym of *C. l. nubilus* by Nowak (1995). The resulting discriminant function plot (Nowak 2002, figure 6) indicated no morphometric convergence between the Texas *C. lupus* and pre-1918 *C. rufus* ($n = 6$), which (although based on a limited sample of *C. lupus* specimens) provided no evidence that interbreeding between these species was occurring in western and central Texas.

Nowak (2003, table 9.3; 2009, figure 3) described the historical range of *C. l. lycaon* as extending south to northern and western New York. Nowak (2003, p. 247) noted that a few Pleistocene specimens indicate that *C. l. baileyi* once extended to Kansas and southern California.

Nowak (2009) focused on the relationships among wolves of the Great Lakes area in a discriminant function analysis of historical skulls intended to portray patterns of variation before wolves were exterminated from much of the area. In the initial comparison of series representing western *C. l. nubilus* (collected before 1930, $n = 27$), northern Minnesota wolves (1970–1975, $n = 23$), and *C. l. lycaon* from Algonquin Provincial Park, Ontario (1964–1965, $n = 20$), there was no overlap between *C. l. lycaon* and either the northern Minnesota or the western *C. l. nubilus*. Most Minnesota series, however, overlapped the polygon for *C. l. nubilus* (Nowak 2009, figure 1). Nowak (2009, figure 15.2) then compared these relationships with two series that are geographically intermediate between Minnesota and Algonquin Provincial Park: Upper Peninsula of Michigan (collected prior to 1966), and a series collected between the Upper Peninsula and Algonquin Provincial Park. Each of these two series overlapped both Minnesota and Algonquin on the discriminant function plots, thus bridging the morphological gap between them.

Mulders (1997) used principal components and discriminant function analyses to study skulls of 525 *C. lupus* from Canada. He found the wolves of the Canadian Arctic Islands (*C. l. arctos* and *C. l. bernardi*) to be distinct from mainland wolves, but not from each other. He interpreted his findings as supporting recognition of the subspecies *C. l. arctos* and Nowak's (1995) treatment of *C. l. bernardi* as its junior synonym. He found support for *C. l. occidentalis* and

C. l. nubilus, but with boundaries different from those proposed by Nowak (1995). He characterized *C. l. occidentalis* as “mainland tundra wolves,” with a range including Yukon, Northwest Territories, Baffin Island, and portions of Manitoba and western Ontario in the vicinity of Hudson Bay. He characterized *C. l. nubilus* as “central boreal wolves,” with a range south of *C. l. occidentalis*, including eastern British Columbia, Alberta, and nearly all of Saskatchewan; these areas were included within the range of *C. l. occidentalis* by Nowak (1995).

Mech and Paul (2008) accepted the recognition of *C. lycaon* as a species separate from *C. lupus*. Based on their analysis of body mass of 950 female and 1,006 male adult wolves from across northern Minnesota, they describe an increasing trend in body mass from east to west for both sexes. They concluded that this trend supports the view that the two species meet and hybridize in northern Minnesota. *C. lupus* in this study would represent *C. l. nubilus* according to Nowak's (1995) distribution map.

Summary of studies on morphology. Studies with comparable geographic coverage agree in that they indicate that smaller wolves occur in the Great Lakes region (eastern wolf), and that size increases to the north and west of that region. The study of Lawrence and Bossert (1967) is not comparable because the influence of size was reduced or eliminated by the selection of specimens and the use of ratios rather than direct measurements of skull characters. Studies that involved *C. l. baileyi* came to different conclusions as to its northern boundary, with Bogan and Mehlhop (1983) favoring a more northerly boundary than did Nowak (1995).

Autosomal microsatellite DNA

Broad patterns of variation in North American *Canis* were investigated (Roy et al. 1994, 1996) using microsatellite DNA. Samples of *C. lupus* from Minnesota and southern Quebec, as well as red wolves *C. rufus*, were intermediate between two large multidimensional scaling clusters (Roy et al. 1996, figure 3, which is reproduced here as Figure 4) representing five populations each of *C. lupus* and coyotes *C. latrans*. The red wolf samples ($n = 40$, Roy et al. 1994) were from the captive-breeding program (derived from red wolves captured in southeastern Texas and southwestern Louisiana [Roy et al. 1994]) and pre-1940 individuals ($n = 16$, Roy et al. 1996) from Texas, Oklahoma, Arkansas, and Missouri. Roy et al. (1994, 1996) attributed the intermediate placement of these red wolves, as well as Minnesota and southern Quebec *C. lupus*, to extensive hybridization between *C. lupus* and coyotes. The possibility of an original evolutionary affinity between *C. rufus* and wolves from southern Quebec and Minnesota was not discussed. The *C. lupus* of northern Quebec ($n = 20$, Roy et al.

1994) were closer to western *C. lupus* from Vancouver Island ($n = 20$), Alberta ($n = 20$), and Kenai Peninsula, Alaska ($n = 19$). A neighbor-joining analysis (Roy et al. 1994, figure 7) of Nei's (1978) genetic distance found northern Quebec wolves to be intermediate between southern Quebec and Minnesota wolves and western *C. lupus* from Vancouver Island, Alberta, Northwest Territories, and Alaska. Red wolves were intermediate to southern Quebec and Minnesota wolves and coyotes.

García-Moreno et al. (1996) compared microsatellite DNA variation in *C. l. baileyi* from the captive-breeding program with 42 dogs and the gray wolf, coyote, and red wolf data presented by Roy et al. (1994). A multidimensional scaling plot of the microsatellite data (García-Moreno et al. 1996, figure 4), showed pronounced separation of *C. l. baileyi* from all the other canids, including other *C. lupus*, although the authors acknowledged that the effects of small founder size and genetic drift in the captive *C. l. baileyi* population may have contributed to their genetic distinctiveness (Paetkau et al. 1997). Red wolves were not included in the Minnesota–Quebec wolf cluster in the multidimensional scaling plot, but appeared within the confidence ellipse of coyotes (García-Moreno et al. 1996, figure 4). A neighbor-joining tree (García-Moreno et al. 1996, figure 5) based on Nei's (1978) genetic distance displayed the captive *C. l. baileyi* lineages close together on a well-supported branch distinct from other *C. lupus*. The same neighbor-joining tree placed the *C. lupus* samples from Minnesota basal to the clade composed of *C. l. baileyi*, western gray wolves, and domestic dogs, while the southern Quebec wolves were basal to the coyote–red wolf clade. Regardless, both the Minnesota and southern Quebec populations were described as “hybridizing gray wolves.”

Several detailed studies have used autosomal microsatellite DNA to characterize the population genetics of wolf recovery in the Northern Rocky Mountains of the United States (Forbes and Boyd 1996, 1997; vonHoldt et al. 2008, 2010). The Montana population is descended from wolves that naturally dispersed from southern Alberta and British Columbia, whereas the Idaho and Yellowstone National Park populations were founded with reintroductions from central Alberta and northern British Columbia. These populations represent the single taxon, *C. l. occidentalis*, in Nowak's (1995) classification. These studies provide fascinating illuminations of pack structure, reproductive behavior, and migration but are not informative on the taxonomic questions that are the subjects of this paper and will not be further considered.

In a study concentrating on the evolutionary relationships of the wolves of eastern Canada, Wilson et al. (2000) reported microsatellite variation

at eight of the loci used by Roy et al. (1994) in comparisons of *Canis* from the vicinity of Algonquin Provincial Park, Ontario (putatively *C. lycaon*), suspected hybridizing (wolf–coyote) wolves from southern Quebec and Minnesota, *C. rufus* from the red wolf captive-breeding program, and *C. lupus* from Northern Ontario, Alberta, and the Northwest Territories. This study also described mitochondrial DNA (mtDNA) control-region sequence variation that will be discussed later. Issues of particular interest were the relationship of *C. lycaon* to *C. rufus* and how hybridization with coyotes may have contributed to the genetic similarities observed between them. Neighbor-joining trees based on Nei's genetic distance (1972 [Wilson et al. 2000, figures 1 and 2]) grouped *C. rufus* with wolves from Algonquin Provincial Park, southern Quebec, and Minnesota, but separate from both coyotes and western *C. lupus*. They concluded that the similarity between eastern Canadian wolves and *C. rufus* was not due to shared introgression from coyotes, because alleles found in the coyote populations were either absent or found at low frequency in *C. rufus* (Wilson et al. 2000, table 1). At these loci, captive *C. rufus* were more similar to Algonquin wolves than to coyotes from Texas, an expected source of introgression into the founders of the captive red wolf population. Individual assignment tests also indicated that Algonquin Provincial Park wolves and *C. rufus* were distinct (probability of identity measure) or nearly distinct (individual index) from Texas coyotes (Wilson et al. 2000, figure 3). These analyses also supported the mutual distance of Algonquin wolves and *C. rufus* from western *C. lupus* (Wilson et al. 2000, figure 4).

Carmichael et al. (2001) studied microsatellite variation in 491 *C. lupus* from nine locations in the Northwest Territories and Yukon of Canada. Analysis of genetic distance using F_{ST} , the fixation index of Wright (1951), and assignment tests, all indicated restricted gene flow between wolves on different sides of the Mackenzie River ($F_{ST} = 0.04$) and little differentiation among wolves on the same side (F_{ST} ranged 0.01–0.02). Rather than topological isolation, the authors associated this barrier with predator–prey specialization on different caribou herds with seasonal migratory patterns that were exclusive to either side of the river. Genetic distances observed between Arctic Island (*C. l. arctos* in Nowak 1995) and mainland (*C. l. occidentalis* in Nowak 1995) wolves (F_{ST} ranged 0.09–0.19) were twice that observed among mainland wolves (F_{ST} ranged 0.01–0.1 [Carmichael et al. 2001, table 2]).

In a study designed to explore pack composition among wolves in Algonquin Provincial Park, Grewal et al. (2004) assessed parent–offspring relationships from mtDNA control-region sequence as well as Y-chromosome and autosomal microsatellite variation.

Wolves at proximal locations in the Frontenac Axis ($n = 74$) and Magnetawan region ($n = 26$), as well as Northeast Ontario ($n = 33$), Abitibi–Temiscamingue region ($n = 13$), and La Verendrye Reserve in southeast Quebec ($n = 13$) were also assessed. The data from the mtDNA sequence and Y-chromosome microsatellite portions of this study will be discussed in following sections. In addition to breeding adults and offspring, most packs were found to have at least one additional, nonbreeding and unrelated adult. STRUCTURE analysis identified five immigrants into the Algonquin Provincial Park: three from Frontenac Axis, one from Magnetawan region, and one from north of the park. Wolves from the Frontenac Axis and Magnetawan region locations exhibited significant introgression from coyote, whereas the genotypes of wolves from north of the park (within the range of *C. l. nubilus* in Nowak 1995) predominantly exhibited *C. lupus* alleles. Algonquin Provincial Park wolves (within the range of *C. l. lycaon* in Nowak 1995 and *C. lycaon* in Wilson et al. 2000) were differentiated from proximal populations (F_{ST} ranged 0.024–0.055), but were approximately twice as divergent from wolves from the more distant Abitibi–Temiscamingue region ($F_{ST} = 0.089$), La Verendrye Reserve ($F_{ST} = 0.091$), and northeastern Ontario ($F_{ST} = 0.076$) localities.

Weckworth et al. (2005) compared microsatellite variation among wolf populations from coastal southeast Alaska ($n = 101$; *C. l. nubilus* in Nowak 1995) and coastal south-central Alaska, interior Alaska, Northwest Territories, and British Columbia ($n = 120$; *C. l. occidentalis* in Nowak 1995) and found that the coastal and continental groups were distinguished by significant differences in allele frequencies. Mean distance between coastal and continental wolves (average $F_{ST} = 0.16$) was nearly twice that of the mean distance within groups (average $F_{ST} = 0.09$). However, wolves from coastal south-central Alaska and coastal southeast Alaska were similarly distinguished (average $F_{ST} = 0.16$). The authors attributed the observed genetic divergence to the waterways, high mountains, and glaciers barring the dispersal of wolves (Weckworth et al. 2005, figure 2). They also hypothesized that southeast Alaska was colonized from the south with the retreat of the last Pleistocene glaciation, whereas interior Alaska had been colonized by wolves from the Beringian refugium to the north (Nowak 1983).

Musiani et al. (2007) compared microsatellite DNA variation in gray wolves from seven localities in tundra–taiga habitat in Northwest Territories, Canada ($n = 337$) and four localities in boreal forest habitat in Northwest Territories and northern Alberta ($n = 67$) to examine the effects of habitat specializations on population structure. GENELAND analysis combined the wolves from tundra–taiga and boreal forest localities into respective populations, and found

significant genetic differentiation ($F_{ST} = 0.03$) between the two. Genetic and geographic distances were not significantly correlated, and topological barriers were not in evidence; therefore, the authors concluded that prey and habitat specialization had promoted the genetic differentiation. The autosomal and Y-chromosome microsatellite data obtained in this study are discussed at length elsewhere.

Carmichael et al. (2007, 2008) explored geographic variation in wolves that inhabited the North American Arctic. Carmichael et al. (2007) focused on the structure of mainland populations, Carmichael et al. (2008) on Canadian Arctic Islands populations. The wolves genotyped in these studies included individuals from the Canadian Arctic Islands ($n = 342$), southeast Alaska coastal islands ($n = 35$), and mainland locations ($n = 1648$) that were attributable to three different subspecies following Nowak's (1995) reclassification and general subspecies boundaries: *C. l. occidentalis*, *C. l. nubilus*, and *C. l. arctos*. Ten populations (Carmichael et al. 2007, figure 2b) were identified through the combined results of STRUCTURE and GENELAND analyses. Carmichael et al. (2007) explained this population divergence in terms of reduced dispersal due to topographic, habitat selection, and prey preference barriers. They noted that the geospatial distribution of the recognized populations did not correspond to the morphological subspecies boundaries in Nowak (1983, 1995), but reflected contemporary factors affecting gene flow.

Sampling areas attributable to *C. l. occidentalis* were generally grouped together in a neighbor-joining tree of genetic distance (Carmichael et al. 2008, figure 3B). However, the sample group from southeast Alaska coastal islands (*C. l. nubilus*, after Nowak 1995) was more similar to proximal interior populations in Alaska, Yukon, Northwest Territories, and British Columbia (*C. l. occidentalis*, after Nowak 1995) than to the cluster of other *C. l. nubilus* sampling areas from Nunavut (Qamianirjuaq and Bathurst) and Atlantic Canada. The Manitoba and British Columbia samples that straddled the eastern and western boundaries between *C. l. occidentalis* and *C. l. nubilus* were both included within the *C. l. occidentalis* portion of the tree. Of the *C. l. nubilus* sampling areas, Baffin Island and an adjacent mainland area occurred together on a well-supported branch, but the wolves of the Atlantic sampling area (including Labrador, New Foundland, New Brunswick, and Nova Scotia) were as divergent from the Baffin-NE Mainland wolves as they were from the Victoria–Banks–High Arctic Islands wolves (Carmichael et al. 2008, table 3).

Consistent with recent repopulation from the south rather than having occupied a separate glacial refuge north of the ice sheet as proposed by Nowak (1983), Canadian Arctic Island wolves exhibited few unique alleles. The lack of isolation of island and

mainland wolf populations was further supported by the observation of high gene flow between mainland and island wolf populations (Carmichael et al. 2008, table 2) and annual over-ice, island–mainland migrations of island wolves (Carmichael et al. 2001) and their caribou prey (Carmichael et al. 2008, figure 4). Although genetic distance between island and mainland populations was generally much higher (D_s ranged 0.08–0.63) than among mainland populations (D_s ranged 0.01–0.30 [Carmichael et al. 2008, table 3]), the effects of small founder size and genetic drift may have contributed to the genetic distinctiveness of Arctic Islands wolves (Paetkau et al. 1997). For example, the High Arctic and Victoria Island populations, as well as the southeast Alaska coastal islands populations, exhibited evidence of inbreeding (F_{IS} ranged 0.18–0.63). As a result, the authors recommended that conclusions about, “the taxonomic validity of *C. l. arctos* should be deferred,” until data are available from mtDNA and Y-chromosome sequences (Carmichael et al. 2008, p. 886).

Wheeldon and White (2009) successfully genotyped three historical wolf specimens from Minnesota and Wisconsin (1899–1908) at six microsatellite loci and characterized them in a STRUCTURE analysis along with wolf and coyote samples from throughout Canada. The microsatellite profiles of both modern and historical western Great Lakes wolves exhibited similar admixture proportions that were attributed to *C. lupus*–*C. lycaon* hybridization. These results suggested that *C. lupus* and *C. lycaon* were sympatric and interbreeding prior to their extirpation from the region in the early 20th century.

Kobl Müller et al. (2009a) used autosomal microsatellite, Y-chromosome microsatellite, and mtDNA sequence analysis to compare modern Great Lakes wolves with eastern ($n = 49$) and western ($n = 78$) coyotes, western *C. lupus* ($n = 58$), and historical Great Lakes wolves (collected prior to the modern establishment of coyotes in the region). The modern Great Lakes wolf sample consisted of some ($n = 64$) of the same Minnesota animals analyzed by Lehman et al. (1991) and Roy et al. (1994), recovered Wisconsin ($n = 16$) and Upper-Peninsula Michigan wolves ($n = 63$), as well as wolves from Ontario ($n = 51$) and Quebec ($n = 9$). The historical sample ($n = 19$) included wolves from Minnesota, Wisconsin, Michigan, Ontario, Quebec, and New York. The Y-chromosome and mtDNA data are discussed separately. STRUCTURE analysis of the Northwest Territories and Great Lakes wolf samples from Minnesota, Wisconsin, and Michigan revealed little evidence of admixture, whereas the authors interpreted the significant admixture observed in wolves from Ontario and Quebec as the result of recurrent hybridization between gray wolves and Great Lakes wolves and between Great Lakes wolves and

coyotes. Genetic divergence was reported in this paper using the notation Θ_{ST} , which is simply Θ , the coancestry parameter, in the original notation of Weir and Cockerham (1984). Little difference was detected between the modern recovered population of Great Lakes wolves and the historical sample ($\Theta = 0.036$). Great Lakes wolves were equally divergent from eastern ($\Theta = 0.142$) and western ($\Theta = 0.133$) coyotes, but less so from western *C. lupus* ($\Theta = 0.078$). The authors did not conclude that Great Lakes wolves constituted a separate species, but rather a unique population or ecotype of *C. lupus*.

Wolf–dog hybridization in the wolf population of Vancouver Island was the subject of study by Muñoz-Fuentes et al. (2010) using microsatellites and mtDNA control-region sequence. Wolves were thought to have been extirpated from the island between 1950 and 1970, after which they recolonized from the adjacent mainland of British Columbia. In contrast to the mtDNA data, the microsatellite data did not reveal evidence of dog introgression. The authors concluded that these results were consistent with a single hybridization event that occurred early in the reestablishment of wolves on the island.

Wilson et al. (2009) explained the genetic relationships of three “races” of wolves living in Ontario, Canada: the larger Ontario and smaller Algonquin types of the eastern timber wolf (*C. l. lycaon*; Kolenosky and Standfield 1975) and the Tweed wolf that is thought to be a wolf–coyote hybrid. The authors assessed the relationships of wolves from across Ontario for evidence of hybrid admixture from autosomal microsatellite variation. The study included wolves from both southern regions of Ontario: Frontenac Axis ($n = 74$), Magnetawan region ($n = 26$), and Algonquin Provincial Park ($n = 92$); and northern regions: northeast Ontario ($n = 33$), northwest Ontario ($n = 30$), and Pukaskwa National Park ($n = 13$). STRUCTURE analysis segregated the sample into three populations (Wilson et al. 2009, figure 3): wolves from the northern regions, which also exhibited *C. lupus* mtDNA (Old World-type, Wilson et al. 2009, table 2) at high frequency (24–85%), eastern wolves from Algonquin Provincial Park (3% *C. lupus* mtDNA), and Tweed wolves from the Magnetawan region and Frontenac Axis in the south (100% *C. latrans*–*C. lycaon* mtDNA, New World-type, Wilson et al. 2009, table 2). The microsatellite genotypes of Frontenac Axis and Magnetawan region wolves were significantly introgressed with coyote alleles (>50% of population), whereas those from north of the park (within the range of *C. l. nubilus* in Nowak 1995) exhibited genotypes of predominantly gray wolf alleles (>70% of population [Wilson et al. 2009, figure 4]). Algonquin Provincial Park wolves (within the range of *C. l. lycaon* in Nowak 1995 and *C. lycaon* in Wilson et al. 2000) were differentiated from

southern Magnetawan region and Frontenac Axis populations (F_{ST} ranged 0.022–0.055, respectively), but were twice as divergent from northern region wolves (F_{ST} ranged 0.071–0.117 [Wilson et al. 2009, table 5]). The authors concluded that eastern wolves of the smaller Algonquin type (Kolenosky and Standfield 1975) are *C. lycaon*, eastern wolves of the larger Ontario type (Kolenosky and Standfield 1975) are *C. lycaon*–*C. lupus* hybrids, and Tweed wolves are *C. lycaon*–coyote hybrids.

Fain et al. (2010) tested the influence of hybridization on wolf recovery in the western Great Lakes states. Microsatellite DNA variation was compared in the recovered Great Lakes states wolf population from Minnesota, Wisconsin, and Upper Peninsula Michigan ($n = 112$); western gray wolves from Alaska, British Columbia, and Alberta ($n = 103$); Wisconsin coyotes ($n = 36$); and domestic dogs ($n = 39$). STRUCTURE analysis clearly segregated Great Lakes states wolves, western gray wolves, coyotes, and dogs (Fain et al. 2010, figure 6); however, the Great Lakes sample included *C. lupus* × *C. lycaon* hybrids (25%). Divergence between Great Lakes wolves (within the range of *C. l. nubilus* in Nowak 1995) and western *C. l. occidentalis* (Nowak 1995) was high ($F_{ST} = 0.125$), and Great Lakes wolves were equally divergent from domestic dogs ($F_{ST} = 0.123$). Moreover, the analysis showed that western Great Lakes wolves and sympatric coyotes were also highly differentiated ($F_{ST} = 0.159$). The authors concluded that this result was inconsistent with recent hybridization. The mtDNA and Y-chromosome data also obtained in this study are discussed separately.

Rutledge et al. (2010b) compared microsatellite DNA variation in gray wolves from northeast Ontario ($n = 51$), eastern wolves from Algonquin Provincial Park ($n = 128$), and coyotes from Frontenac Axis ($n = 38$) in eastern Ontario in order to examine the effects of hybridization on population structure. GENELAND analysis segregated the three localities (separated by 700 km) into genetically differentiated populations (F_{ST} ranged 0.052–0.120), but there was evidence of admixture. Algonquin Provincial Park wolves were admixed with both northeast Ontario ($n = 8$, 6%) and Frontenac Axis ($n = 14$, 11%) wolves, and >15% of northeast Ontario and Frontenac Axis wolves were admixed with Algonquin Provincial Park wolves. Principal components analysis of individual autosomal microsatellite genotypes placed Algonquin Provincial Park wolves closest to Frontenac Axis wolves and revealed a south–north cline in allele frequencies. These results were considered supportive of the hypothesis that eastern wolves in Algonquin Provincial Park represent a conduit of gene flow between gray wolves to the north and coyotes to the south. In addition, mtDNA and Y-chromosome haplotype frequency distributions were consistent with the

hypothesis that introgression was gender-biased with females of the smaller species mating males of the larger species. Conspecific pairings at Algonquin Provincial Park were more common than predicted by random mating. The mtDNA and Y-chromosome data obtained in this study are discussed further in following sections.

Wheeldon et al. (2010) evaluated the species distinction of the wolves from the western Great Lakes region. The authors analyzed species-specific mtDNA and Y-chromosome sequence haplotypes in addition to autosomal microsatellite variation. The Y-chromosome and mtDNA sequence haplotype data are discussed elsewhere. The sample included 410 wolves and coyotes from the western Great Lakes states (Minnesota, Michigan, and Wisconsin) and western Ontario. Wolves and coyotes were distinguished as separate populations in both STRUCTURE and factorial correspondence analysis, with little indication of hybridization. Y-chromosome and mtDNA haplotypes of both eastern and gray wolves were found in the wolf sample. The lack of subdivision of the wolf sample in the STRUCTURE analysis was cited as evidence that the wolves of the western Great Lakes states and western Ontario are members of a single interbreeding population.

Summary of studies of autosomal microsatellite DNA. Although many of these studies did not address questions of taxonomy, when viewed together, they generally distinguish groups representing western gray wolves, eastern wolves (alternatively referred to as Great Lakes wolves in some studies), red wolves, Mexican wolves, and coyotes. Most studies in the western Great Lakes region found the wolves to comprise an admixed population. There is disagreement on the source of the admixture: some researchers claim that it represents gray wolf–coyote interbreeding (Roy et al. 1994, 1996; García-Moreno et al. 1996), while others claim that it represents gray wolf–eastern wolf interbreeding (Wilson et al. 2000; Wheeldon and White 2009; Wilson et al. 2009; Fain et al. 2010; Wheeldon et al. 2010). Autosomal microsatellite DNA data were interpreted by Carmichael et al. (2007, 2008) as failing to support Nowak's interpretation, based on his morphometric analysis, of long isolation and subspecific validity of the arctic wolf, *C. l. arctos*.

Single-nucleotide polymorphisms

vonHoldt et al. (2011) reported the results of whole-genome analysis of 48,036 single-nucleotide polymorphism markers in worldwide samples of dogs and wild canids. Wild canids from North America include 57 coyotes, 12 red wolves, 19 Great Lakes wolves, and 70 gray wolves. In a principal components analysis (vonHoldt et al. 2011, figure 3), the first component (accounting for 10% of the total variance) separated domestic

dogs from the wild canids, and the second component (accounting for 1.7% of the variance) separated coyotes and red wolves from other North American wolves. A successive series of STRUCTURE analyses first distinguished dogs from wild North American canids ($K = 2$), coyote and red wolf from other wolves ($K = 3$), Mexican wolf from other gray wolves ($K = 6$), red wolf from coyote ($K = 9$), and Great Lakes wolves from gray wolves ($K = 10$). A SABER ancestry analysis was performed on Great Lakes wolves (including two individuals from Algonquin Provincial Park) and red wolves using western gray wolves, dogs, and western coyotes as ancestral reference populations. Conclusions by vonHoldt et al. (2011) include: red wolf is an admixed variety derived from coyote; the Great Lakes wolf is an admixed variety derived from gray wolves, but is genetically distinct from other gray wolves; the Mexican wolf is a distinct form of gray wolf; and that within gray wolves, geographic variation in single-nucleotide polymorphism composition is attributed to geographic variation in ecological conditions rather than to taxonomic distinctions.

Mitochondrial DNA

Lehman et al. (1991) used restriction analysis of the entire mtDNA genome to describe haplotype variation in wolves and coyotes in areas of sympatry, as well as allopatry to assess the occurrence of interspecies hybridization. The sample included wolves from Minnesota, Isle Royale in Lake Superior, western Ontario, Algonquin Provincial Park, Québec, and selected western localities extending to Nome, Alaska. A maximum parsimony tree (Lehman et al. 1991, figure 3) separated western *C. lupus* from coyotes and wolves from the Great Lakes region. Although some Great Lakes wolves exhibited *C. lupus* haplotypes, most shared haplotypes with coyotes, or had “coyote-type” haplotypes (i.e., phylogenetically similar but not observed in coyotes). All wolves sampled from southern Québec and southeastern Ontario exhibited either coyote or coyote-type haplotypes. Lehman et al. (1991) concluded that Great Lakes wolves have a history of repeated hybridization with coyotes with the consequent introgression of coyote mtDNA haplotypes. They suggested that “boreal-type” (in the sense of Kolenosky and Standfield [1975]) and *C. l. lycaon* from north of the portion of their range also occupied by coyotes may represent “pure wolf lines,” while the “Algonquin-type” wolves to the south have been subject to coyote introgression. Because the most common coyote-type haplotypes found in Minnesota wolves were not found in coyotes, the authors suggested that hybridization involving those wolves occurred “in the distant past.” They also stated (p. 115) that, because both *C. lupus* and coyote-type

haplotypes occurred in individuals within the same packs, the Great Lakes region may contain a complex mix of *C. lupus*, coyotes, and their hybrids.

Wayne and Jenks (1991) evaluated the genetic integrity of the source population from which the founders of the red wolf captive-breeding program were selected. Seventy-seven canids were captured in southeastern Texas and southwest Louisiana in the 1974–1976 effort to rescue the last remaining wild *C. rufus*, and included the four matrilineages used to found the red wolf captive-breeding program (USFWS 1990). These animals were characterized morphologically as coyotes (58%), *C. rufus*–coyote hybrids (31%), and *C. rufus* (11%). Genetic characterization of these same animals with whole mtDNA genome restriction analysis found that they exhibited either coyote (84%) or gray wolf (16%) mtDNA and that the morphological and genetic classifications often did not correspond. Moreover, seven individuals (9% of the sample) exhibited a mtDNA restriction type previously observed only in Mexican wolves *C. l. baileyi*, and parsimony analysis placed the mtDNA restriction type observed in captive red wolves within the phylogenetic clade composed exclusively of coyote types. The captive red wolf type was indistinguishable from a haplotype (i.e., C32) found in coyotes from Louisiana. In another part of this study, a portion of the mtDNA cytochrome *b* gene sequence was determined from historical (1905–1930) museum skins identified as *C. rufus* from Texas ($n = 1$), Louisiana ($n = 1$), Arkansas ($n = 2$), Oklahoma ($n = 1$), and Missouri ($n = 1$). Sequences were compared with similarly characterized gray wolf ($n = 2$), Mexican wolf ($n = 1$), coyote ($n = 6$), dog ($n = 1$), and golden jackal *Canis aureus* ($n = 1$) reference samples. The *C. l. baileyi* haplotype differed by only a single substitution from sequences of three historical red wolf specimens from Louisiana, Oklahoma, and Texas, which had a haplotype identical to a *C. lupus* individual from Minnesota. The *C. l. baileyi* haplotype was 10–19 nucleotide substitutions different from those of *C. rufus* from Arkansas, Missouri, and the captive population.

Wayne et al. (1992) used whole mtDNA genome restriction analysis to study variation in *C. lupus*, mostly from North America ($n = 204$), but included Eurasian samples for comparison ($n = 35$). North American wolves exhibited five haplotypes, Eurasian wolves seven, and none were shared. Subspecies assignments were not identified, but the distributions of wolf haplotypes *W1* through *W4* among North American wolves may have a bearing on the standing and relationships of the subspecies *C. l. nubilus* and *C. l. occidentalis*. The *W3* haplotype was the most common and widespread, from Alaska to Montana, but not found in samples from Manitoba, which all ($n = 4$) had the unique *W2* haplotype. Haplotype *W1* was found from the Northwest Territories to

Montana (and later also found in Minnesota and central Ontario [Wayne et al. 1995]), and *W4* was found in scattered locations from Alaska to Montana. These haplotypes all differed by one or two restriction sites (about 0.1–0.2% sequence divergence). The fifth haplotype (*W14*) was found only in the *C. l. baileyi* samples from the Mexican wolf captive-breeding program. This haplotype was most closely associated with Eurasian *C. lupus* in the phylogenetic analysis (Wayne et al. 1992, figure 2). Altogether, eastern wolves ($n = 106$) from Manitoba, Minnesota, Michigan, Ontario, and Quebec exhibited seven “coyote-derived” haplotypes.

Roy et al. (1996) tested the hypothesis that red wolves are evolutionarily ancestral to both gray wolves and coyotes but had undergone a recent interval of interbreeding with coyotes at the time of their near extermination in the wild. A portion of the mtDNA cytochrome *b* gene was sequenced from historical (1919–1943) museum skins of *C. rufus* ($n = 11$) and compared with those described by Wayne and Jenks (1991) from additional historical *C. rufus* ($n = 6$), captive *C. rufus* ($n = 1$), *C. lupus* from Alaska ($n = 1$), *C. lupus* from Minnesota ($n = 1$), *C. l. baileyi* ($n = 1$), *C. latrans* ($n = 5$), and *C. aureus* ($n = 1$). The observed haplotypes comprised two major clades, one including all coyotes, the other gray wolves. Most *C. rufus* were placed in the “coyote clade” ($n = 8$), but others from Missouri and Oklahoma ($n = 3$) were included in the wolf clade. Only haplotype *CruOK3* was common to the different sets of historical red wolf samples.

Sequence divergences were consistent within species: *C. rufus* (0.4–0.9%), *C. latrans* (0.4–1.7%), and *C. lupus* (0.4–1.3%). Sequence divergence between *C. lupus* and *C. latrans* was about four-fold greater (3.2–5.6%) and *C. lupus* were >3.2% divergent from *C. rufus* from Arkansas, Oklahoma, and Texas, but <2.1% divergent from *C. rufus* from Missouri and Oklahoma. The authors concluded that introgression of *C. lupus* into *C. rufus* had occurred in Oklahoma and Missouri but not in Arkansas and Texas. The divergence observed between the 16 historical *C. rufus* sequences and gray wolf and coyote references was consistent with the amount of within-species variation found in gray wolves and coyotes. The results of the microsatellite analysis performed in this study are discussed in the preceding section.

Vilà et al. (1999) included data from North American *C. lupus* ($n = 24$) in a broad-scale phylogeographic study of mtDNA control-region sequence variation in wolves (Vilà et al. 1999, figure 1, which is reproduced here as Figure 9). The phylogenetic tree that resulted from a neighbor-joining analysis placed *C. l. baileyi* basal to all other wolf clades, while the five other North American haplotypes sorted into three different clades that

each included Eurasian *C. lupus*. There was no obvious geographic pattern in the distribution of these haplotypes, but the scale of sampling was too coarse for this purpose. The single haplotype shared by the six individuals of *C. l. baileyi* was unique and was more similar to certain Eurasian wolves than to other North American *C. lupus*. Vilà et al. (1999, p. 2099) suggested that *C. l. baileyi* may represent an early invasion of North America by Eurasian wolves, before the arrival of *C. lupus* with other haplotypes. The phylogenetic analysis also included the mtDNA control-region sequence of a single Texas *C. rufus*. The *C. rufus* sequence was not found in coyotes, although it was within the coyote clade of the neighbor-joining tree.

Wilson et al. (2000) examined the origin and taxonomy of the wolves of eastern Canada, and whether they are the result of hybridization between gray wolves and coyotes as has been suggested for the red wolf (Roy et al. 1996). Wilson et al. (2000, figures 5A and 5B, reproduced here as Figures 5 and 6, respectively) compared the mtDNA control-region sequences of historical wolves (1960–1965) from the vicinity of Algonquin Provincial Park ($n = 13$) and southern Ontario ($n = 8$), Texas coyotes ($n = 27$), captive *C. rufus* ($n = 12$), and *C. lupus* from Manitoba, northern Ontario, northern Quebec, and the Northwest Territories ($n = 9$). The authors found no gray wolf sequences in historical Algonquin wolves or in captive *C. rufus*. Moreover, captive red wolves and historical Algonquin wolves exhibited unique haplotypes not found in either *C. lupus* or coyotes. Phylogenetic analyses revealed a similarity between the unique haplotypes *C1* of Algonquin wolves, *C3* found in a single modern Manitoba wolf, and *C2* found in captive red wolves (Wilson et al. 2000, figure 5). This group was strongly separated from the wolves of western and northern Ontario as well as the Northwest Territories. Other eastern Canadian wolves had haplotypes grouped by the analyses with coyote haplotypes, although most were not found in western coyotes (Lehman et al. 1991; Wilson et al. 2000).

Wilson et al. (2000) attributed the existence of the unique “coyote-like” haplotypes in Algonquin wolves and *C. rufus*, as well as the ability of these canids to hybridize with coyotes, to their having shared a more recent common ancestor with coyotes in the New World rather than with the more distantly related, Old World-evolved *C. lupus*. Based on this relationship, they concluded that eastern Canadian wolves should not be considered a subspecies (*C. l. lycaon*) of gray wolf, but as a full species, *C. lycaon*, closely related to, if not conspecific with, *C. rufus*. If conspecific with *C. rufus*, Wilson et al. (2000, p. 2165) suggested that the name that might best apply would be *C. lycaon*, based on “historical taxonomic classifications.” Wilson et al. (2000) maintained that *C. lycaon* ranged into

Minnesota, northwestern Ontario, and Manitoba, and suggested that *C. lycaon* and *C. lupus* may be interbreeding in these western reaches.

Eight *C. lupus* individuals from five different North American localities were also characterized in this study. Although three haplotypes (i.e., *C22*, *C23*, and *C24*) were found, the scale of sampling was too coarse to detect any obvious geographic pattern in their distribution. For example, Ontario and Manitoba wolves should represent *C. l. nubilus*, but haplotype *C23* was found there as well as in the Northwest Territories where wolves represent *C. l. occidentalis* (Nowak 1995; Table 5 in this paper). As discussed in the preceding section, Wilson et al. (2000) also characterized microsatellite variation in wolves from across Ontario, Quebec, and western Canada.

To test the hypothesis that eastern wolves evolved in North America, Wilson et al. (2003) obtained mtDNA control-region sequences from the hides of two historical wolves, one from New York state (collected in the 1890s) and the other from Penobscot County, Maine (in the 1880s). Both animals were presumed unaffected by coyote hybridization because they had been collected prior to the invasion of the eastern United States by western coyotes. The authors suggested that the exhibition of “coyote-like” haplotypes by these animals would indicate a most recent common ancestor between eastern wolves and coyotes rather than gray wolves. In both neighbor-joining and maximum parsimony analyses (Wilson et al. 2003, figure 1) neither specimen clustered with *C. lupus* samples from northern Ontario, northern Quebec, Manitoba, the Northwest Territories, or Europe. The haplotype of the Maine individual was identical to the unique *C. lycaon* haplotype *CI* previously identified from Algonquin Provincial Park wolves. The New York sample clustered with modern western coyotes, although this haplotype (*CI3*) was not identical to any reported from coyotes and was referred to by the authors as “coyote-like.” The authors interpreted these findings as supporting both the presence of *C. lycaon* in Maine and New York in the 1880s and their earlier contention (Wilson et al. 2000) that *C. lycaon* and *C. rufus* represent an eastern wolf with an evolutionary history separate from that of *C. lupus*.

Adams et al. (2003) compared the mtDNA control-region sequences of the four matriline of the red wolf captive-breeding program ($n = 8$), red wolf-coyote hybrids ($n = 40$) collected from the Alligator River National Wildlife Refuge in northeastern North Carolina (Adams et al. 2003; figure 1), and coyotes collected from locations in California, Kentucky, Nebraska, North Carolina, Texas, and Virginia ($n = 66$). The authors found that the four matriline of the 14 red wolf founders of the captive-breeding program had identical control-region

sequences, haplotype *Cru* (same as *C2*, Wilson et al. 2000), and when compared with haplotypes observed in coyotes proximal to the red wolf experimental population (i.e., 14 haplotypes found in North Carolina and Virginia coyotes, $n = 50$) and the published literature (i.e., 12 coyote haplotypes), *Cru* was unique. The average sequence divergence between haplotype *Cru* and these 26 coyote haplotypes was 3.24% (range = 1.2–10%). The average sequence divergence among these coyote haplotypes was 2.79% (range = 0.3–11%).

In a study designed primarily to explore the pack composition of wolves in Algonquin Provincial Park, Grewal et al. (2004) reported on the variation of mtDNA control-region sequence haplotypes ($n = 261$), Y-chromosome microsatellite haplotypes ($n = 248$), and autosomal microsatellite genotypes ($n = 261$) among wolves at various locations in Ontario and Quebec. The data from the autosomal and Y-chromosome microsatellite portions of this study are discussed in the preceding and following sections. Mitochondrial DNA haplotypes were identified as being of *C. lupus* (*C22*), *C. lycaon* (*CI*, *C9*), or coyote (*CI3*, *CI4*, *CI6*, *CI7*, *CI9*); but see the summary of the study of mtDNA variation of Wheeldon and White (2009) for an alternative interpretation of *CI3*). The species source of the rare haplotypes *C3* and *C36* were not identified. *C. lupus* mtDNA haplotypes were uncommon (4 of 102 individuals) in wolves at Algonquin Provincial Park, but were 10 times more common to the north (La Verendrye Reserve) and west (northeastern Ontario) of Algonquin Park (Table 5 of this paper). *C. lycaon* mtDNA haplotypes were observed at higher frequency and coyote haplotypes at lower frequency to the south (Frontenac Axis) of Algonquin Provincial Park (Grewal et al. 2004, figure 2, table 1). Grewal et al. (2004) suggest that coyote haplotypes probably introgressed into Algonquin Park wolves during the 1960s when the population was reduced and coyote-wolf hybrids (“Tweed wolves” of Kolenosky and Standfield [1975]) expanded into the park.

Leonard et al. (2005) obtained mtDNA control-region sequences from 34 museum specimens of *C. lupus* collected from the conterminous United States and Labrador prior to the extirpation of wolves (i.e., 1917 or earlier) to determine the proportion of the variation that has been retained by extant populations of wolves in Alaska, Canada, and northeast Minnesota. The sample of historical wolves included individuals identified morphologically and by geographic provenance as *C. l. baileyi* ($n = 8$), *C. l. labradorius* ($n = 4$), *C. l. nubilus* ($n = 16$), and *C. l. youngi* ($n = 6$). The 13 mtDNA haplotypes observed in these historic wolves were sorted into northern and southern clades by phylogenetic analysis. The northern clade, representing *C. l. nubilus-youngi-labradorius* (combined under *C. l. nubilus*; Nowak 1995), included nine haplotypes, three of which are

common in modern wolves (i.e., *lu28*, *lu32*, and *lu38*). The southern clade, representing *C. l. baileyi*, included four haplotypes, only one of which remains in modern Mexican wolves (i.e., *lu33*). An historical *C. l. baileyi* sample from Chihuahua, Mexico, (USNM98313/JAL474) exhibited an mtDNA haplotype (*lu60*) that is otherwise known only from coyotes. Overall, 58% of the historical wolf samples exhibited the same four haplotypes observed in the modern wolf sample. Eight haplotypes found in historical wolves were not observed in modern wolves. Individuals with southern clade haplotypes were found as far north as Utah, Colorado, and Nebraska; whereas, northern haplotypes were found as far south as Arizona. The authors (p. 15) explained this observation as genetic evidence of population interaction: “In highly mobile species, large zones of intergradation may characterize subspecies boundaries ...”

Musiani et al. (2007) used variation in mtDNA control-region sequence, and Y-chromosome and autosomal microsatellites to examine the effects of habitat specialization on population structure in wolves from northern Canada. The autosomal and Y-chromosome microsatellite results are discussed in respective sections. Mitochondrial DNA control-region haplotype frequency and diversity were analyzed in gray wolves from tundra–taiga ($n = 337$) habitat in Northwest Territories, and boreal forest habitat ($n = 67$) in Northwest Territories and northern Alberta. Nine different haplotypes were characterized; two predominated in tundra–taiga wolves (89% of sample). Although eight haplotypes were found in boreal forest wolves, the two most common haplotypes comprised only 42% of the sample (Musiani et al. 2007, figure 5). Haplotype frequencies differed between habitat types. For example, haplotype *lu32* was observed in both samples but was far more common among tundra–taiga wolves (71% of sample) than in boreal forest wolves (22% of sample). Similarly, mitochondrial gene diversity was three times higher in wolves from boreal forest habitat than in tundra–taiga wolves (0.051 and 0.153, respectively). Genetic differentiation between wolves of different sexes from boreal forest and tundra–taiga habitats was three times higher for females ($F_{ST} = 0.353$) than males ($F_{ST} = 0.138$). Consistent with the autosomal microsatellite analysis, the mtDNA control-region sequence data also supported the characterization of boreal forest and tundra–taiga wolves as separate populations (but see results obtained from Y-chromosome microsatellite variation). The authors concluded that sex bias, likely due to natal habitat-biased dispersal, had contributed to the population differentiation reflected by mtDNA variation ($F_{ST} = 0.28$).

Leonard and Wayne (2008) investigated the controversy surrounding wolf–coyote hybridization

and its impact on the recovery success of western Great Lakes wolves. They compared mtDNA control-region sequences from historical wolves ($n = 12$, collected 1905–1916) and 18 modern wolves ($n = 18$) from portions of Michigan, Wisconsin, and Minnesota. All 12 historical specimens exhibited what the authors termed “Great Lakes” haplotypes (i.e., *GL1*, *GL2*, *GL3*, *GL5*, and *GL8*) that were basal to modern coyote haplotypes in a parsimony consensus cladogram (Leonard and Wayne 2008, figure 1). No historical sample exhibited a haplotype from the clade that included western gray wolf haplotypes. By comparison, the composition of the haplotypes in the modern samples was: Great Lakes: 50%; *C. lupus*: 6%; coyote-like: 44%. In the modern samples, coyote-like haplotypes occurred in Minnesota and Michigan, but the Michigan sample was small ($n = 2$) and no modern Wisconsin wolves were sampled. Both *C. lupus* and Great Lakes haplotypes were found in modern Minnesota wolves. The authors concluded that historical Great Lakes wolves were characterized by phylogenetically distinct haplotypes representing an endemic “American wolf” and that these had been replaced by a modern population of mixed *C. lupus* and coyote ancestry.

Hailer and Leonard (2008) explored the relationships of three canid species, historically sympatric in central Texas, for evidence of hybridization by using an analysis of mtDNA control-region sequence and Y-chromosome microsatellite haplotypes. The Y-chromosome data are discussed in a following section. The sample included wolves from the captive-breeding programs for *C. l. baileyi* ($n = 16$) and *C. rufus* ($n = 5$), as well as wild *C. latrans* from Texas ($n = 53$) and Nebraska ($n = 75$). These were compared with each other and with similarly characterized reference animals from previously published studies (Vilà et al. 1999; Adams et al. 2003; Leonard et al. 2005). All *C. rufus* had coyote-like control-region haplotype *ru1* (Vilà et al. 1999, same as *Cru* in Adams et al. 2003) that was distinct from *C. l. baileyi*. Although possibly of coyote origin, haplotype *ru1* was not observed in any of the coyotes ($n = 131$) in the study. The *lu60* haplotype found in an historical *C. l. baileyi* skull (Leonard et al. 2005) differed by two base changes from the Texas coyote haplotype *la86* and was interpreted as possible evidence of past coyote introgression into *C. l. baileyi*. A single Texas coyote exhibited the mtDNA haplotype *Clal2*, which was phylogenetically most similar to the gray wolf haplotype *lu32* (figure 2, Hailer and Leonard 2008). Haplotype *lu32* has also been observed in historical Mexican wolves (Leonard et al. 2005) and the authors suggested that introgression between Mexican wolves and coyotes may have been the route by which this marker entered the Texas coyote population.

Wheeldon and White (2009) addressed the attestation (Leonard and Wayne 2008) that phylogenetically

distinct historical Great Lakes wolves have been replaced by a modern population of mixed *C. lupus* and coyote ancestry. In addition to the microsatellite DNA data summarized previously, Wheeldon and White (2009) compared the mtDNA control-region sequences of three historical specimens (1899–1908) from Minnesota and Wisconsin. The Wisconsin specimen displayed the *C. lycaon* *C1* haplotype identified by Wilson et al. (2000) in Algonquin wolves, whereas the two Minnesota specimens exhibited the coyote-like *C13* haplotype also found in an historical (circa 1890s) wolf hide from New York (Wilson et al. 2003). Wilson et al. (2003) and Wheeldon and White (2009) considered *C13* to be a *C. lycaon* haplotype related to coyote haplotypes through introgression either before European settlement or much earlier in the Pleistocene. Both haplotypes were identical to those observed in other historical wolves from the Great Lakes region (Koblmüller et al. 2009a, figure 2a). Wheeldon and White (2009) interpreted these data as supporting an historical western Great Lakes wolf population with genetic composition similar to the wolves currently populating the region. The authors' analyses of autosomal microsatellite DNA data are discussed in the preceding section.

Wheeldon et al. (2010) analyzed species-specific mtDNA sequence haplotypes and Y-chromosome and autosomal microsatellite variation in 410 wolves and coyotes from the western Great Lakes states (Minnesota, Michigan, and Wisconsin) and western Ontario. The Y-chromosome and autosomal microsatellite data are discussed separately. Both eastern wolf and gray wolf haplotypes were found in the wolf sample; however, no coyote haplotypes were found. The authors used the species attribution criteria of Wilson et al. (2000) to describe the observed haplotypes. In the combined sample of wolves from Minnesota, Wisconsin, and Michigan ($n = 203$), *C. lycaon* mtDNA control-region sequence haplotypes *C1*, *C3*, and *C13* were more prevalent ($n = 134$, 66%) than *C. lupus* haplotypes *C22*, *C23*, and *C97* (34%). In contrast, wolves from northern Ontario ($n = 135$) more commonly exhibited *C. lupus* haplotypes (56%) than *C. lycaon* haplotypes (44%). Geospatial maps of the distribution of *C. lycaon*, *C. lupus*, and *C. latrans* mtDNA haplotypes revealed that they occur together throughout the western Great Lakes region (Wheeldon et al. 2010, figure 1). Furthermore, 44% of male western Great Lakes states wolves ($n = 43$) displayed both *C. lupus* and *C. lycaon* mtDNA and Y-chromosome markers. The authors concluded that the wolves of the western Great Lakes region are hybrids of gray wolves (*C. lupus*) and eastern wolves (*C. lycaon*). Unlike *C. lycaon* in southeastern Ontario, which has hybridized extensively with coyotes (Grewal et al. 2004; Rutledge et al. 2010b), no wolves were found to exhibit coyote mtDNA haplotypes and only one

coyote was found with a wolf mtDNA haplotype (Wheeldon et al. 2010, table 1).

Koblmüller et al. (2009a) addressed questions regarding the evolutionary origin of Great Lakes wolves, as well as historical and ongoing hybridization between Great Lakes wolves, western gray wolves, and coyotes. Koblmüller et al. (2009a) compared the mtDNA control-region sequence haplotypes of modern and historical ($n = 19$, 1892–1916) wolves from the Great Lakes region, as well as reference populations of coyotes and western gray wolves (*C. lupus*). Although these data were not presented in such a way as to be able to determine the respective haplotype frequencies observed in wolves from the various modern ($n = 6$) and historical ($n = 7$) Great Lakes region sampling localities, the authors summarized their results with a phylogenetic analysis (neighbor-joining tree), and identified coyote (containing all coyote individuals) and wolf clades (containing all western *C. lupus* individuals). The analysis placed most Great Lakes wolves ($n = 142$) in the coyote clade, but they were also well-represented in the wolf clade ($n = 75$). The authors concluded that Great Lakes wolves are gray wolves (*C. lupus*) that have been influenced by repeated hybridization with coyotes in both ancient and recent times. They also concurred with the conclusions of Leonard and Wayne (2008) that historical Great Lakes wolves were characterized by phylogenetically distinct haplotypes representing an endemic “American wolf” and that these have been replaced by a modern population of mixed *C. lupus* and coyote ancestry. The autosomal and Y-chromosome microsatellite DNA data obtained in this study are summarized elsewhere.

Muñoz-Fuentes et al. (2009, figure 3, which is reproduced here as Figure 11) observed a pronounced differentiation in mtDNA control-region sequence variation between coastal and inland wolves in British Columbia and other localities in western Canada and Alaska. They attributed this distinction to local discontinuities in vegetation cover and prey composition and preferences of dispersing wolves for habitats similar to where they were reared. Although genetic differentiation between all localities was significant, coastal and inland populations were most different and haplotype frequency and composition among coastal wolves were markedly different (Table 5 of this paper). Differentiation between historical samples of *C. l. nubilus* ($n = 19$; Leonard et al. 2005) and modern *C. l. occidentalis* ($n = 118$; Muñoz-Fuentes et al. 2009, table 2) was high ($\Phi_{ST} = 0.124$, where Φ_{ST} is a measure of DNA haplotype divergence [Excoffier et al. 1992]), but differentiation between coastal British Columbia wolves ($n = 75$) within the range of *C. l. nubilus* in Nowak (1995) and historical *C. l. nubilus* was even greater ($\Phi_{ST} = 0.550$).

Muñoz-Fuentes et al. (2009) observed that this differentiation supported the recognition of coastal British Columbia wolves as a discrete management unit (Moritz 1994).

Assessments of mtDNA control-region sequence variation by Muñoz-Fuentes et al. (2010) detected evidence of wolf-dog hybridization in wolves that recolonized Vancouver Island after extirpation in the 1950s. The single mtDNA haplotype *lu68* found in all 13 available pre-extirpation specimens (collected 1910–1950) was observed in only 5% of the recovered Vancouver Island population and 25% of the coastal mainland population (Muñoz-Fuentes et al. 2009). The recovered population primarily exhibited haplotype *lu38* (95%), which was also common (68%) on the mainland coast of British Columbia (Muñoz-Fuentes et al. 2009). Although the mtDNA data indicated evidence of dog introgression, the microsatellite data that were also collected in this study did not (discussed in the preceding section). These results were found to be consistent with a rare hybridization event that occurred early in the re-establishment of wolves on the island.

Rutledge et al. (2010a) tested the hypothesis that hundreds of years before the eastward expansion of coyotes, the wolf of the temperate forests of eastern Canada was a gray wolf. Four historical (circa 1500–1600) *Canis* skull fragments (i.e., three teeth and a lower mandible with two in situ teeth) were obtained from a pre-European-contact Iroquois village archaeological site in southern Ontario, Canada. None of the remains exhibited gray wolf mtDNA, but tooth samples L1Va3 and L1Va5 had mtDNA sequence haplotypes previously found in ancient Old World dogs (Vilá et al. 1997; Leonard et al. 2002), and the remaining tooth L1Va4 and mandible L1Va6 exhibited mtDNA haplotypes similar to coyotes from Saskatchewan (Rutledge et al. 2010a, figure 5). Tooth sample L1Va4 had been found in context with the mandible L1Va6, and morphometric analysis identified this bone specimen as being outside the size range of coyotes and likely of eastern wolf origin. The authors concluded that the combined genetic and morphometric data suggest that the archaeological remains are of eastern wolf, *C. lycaon*, origin and that the historical wolf of eastern Canada was not the gray wolf *C. lupus*. However, they added that the data were also consistent with a *C. lycaon*–*C. lupus* hybrid origin (Wheeldon and White 2009).

Rutledge et al. (2010b) tested the hypothesis that eastern wolves have mediated gene flow between gray wolves and coyotes in the region of Algonquin Provincial Park, Ontario. Mitochondrial DNA control-region sequence haplotypes were developed for wolves from northeastern Ontario ($n = 51$), Algonquin Provincial Park ($n = 127$), and Frontenac Axis ($n = 38$). The autosomal and Y-chromosome

microsatellite data also obtained in this study are discussed in respective sections. The frequency and composition of the mtDNA haplotypes observed were consistent with the observations of Wilson et al. (2000) and Grewal et al. (2004) for wolves in Algonquin Provincial Park (Rutledge et al. 2010b, table 3). Wolf clade mtDNA haplotypes were observed at high frequency in northeastern Ontario (53%), low frequency in Algonquin Provincial Park (7%), and were absent in the southern-most, Frontenac Axis sample. Coyote clade mtDNA haplotypes attributed to *C. lycaon* were common in both northeastern Ontario (14%) and Algonquin Provincial Park (16%), and occurred at high frequency in Frontenac Axis wolves (61%). Coyote haplotypes were observed at moderate frequency in northeastern Ontario (33%) and Frontenac Axis (39%) but occurred at highest frequency in Algonquin Provincial Park wolves (77%; Table 5 of this paper). Female breeders at Algonquin Provincial Park had a higher frequency of *C. lycaon* haplotypes (36%) than did the total sample. These results are in general agreement with the separation of *C. l. nubilus* and *C. l. lycaon* range along a transect from the juncture of Lake Superior and Lake Huron eastward to the Quebec border (Nowak 1995).

Fain et al. (2010) examined the taxonomic relationships of wolves in the western Great Lakes states and tested the influence of coyote hybridization on wolf recovery in the region. Mitochondrial DNA control-region sequence haplotypes were developed for wolves sampled from Minnesota ($n = 42$), Wisconsin ($n = 65$), Upper Peninsula Michigan ($n = 17$), and western wolves from Alaska ($n = 40$), British Columbia ($n = 25$), and Alberta ($n = 25$). The study also included Wisconsin coyotes ($n = 132$). The autosomal and Y-chromosome microsatellite data also obtained in this study are discussed in the preceding and following sections, respectively. The authors found the data from all three marker types to support the recognition of *C. lycaon* as a unique species of North American wolf in the western Great Lakes states. The frequency and composition of the mtDNA haplotypes observed were consistent with the observations of Grewal et al. (2004) for wolves in northwest Ontario because fully two-thirds of the combined western Great Lakes states sample exhibited mtDNA haplotypes of *C. lycaon* (see Fain et al. 2010, figure 3 for species attribution of haplotypes). Also similar to northwest Ontario, there was substantial contribution from *C. lupus* because haplotypes *lu28* and *lu32* were observed in a third of the population (see Table 5 of this paper). The geographic scale of the *C. lycaon*–*C. lupus* hybrid zone was indicated by the observation of *C. lycaon* mtDNA haplotypes as far west as northwestern Minnesota and *C. lupus* mtDNA haplotypes in eastern Upper Peninsula, Michigan (Fain et al. 2010, figure 2). The *C. lupus*- and *C. lycaon*-derived mtDNA

haplotypes observed in western Great Lakes wolves were exclusive of sympatric *C. latrans* and inconsistent with ongoing hybridization with coyotes.

Stronen et al. (2010) combined morphological characters (body mass and skull features) and species-specific mtDNA control-region sequence haplotypes to assess wolf–coyote hybridization in wolves from Riding Mountain National Park ($n = 19$) and Duck Mountain Provincial Forest ($n = 8$) in Manitoba. Additional wolf samples from northern Manitoba ($n = 13$) and Prince Albert National Park, Saskatchewan ($n = 24$) were characterized for mtDNA haplotype only. The eastern wolf mtDNA haplotype *C3* was observed in 50% of the Duck Mountain Provincial Forest sample but was not observed elsewhere in Manitoba or Saskatchewan (see Stronen et al. 2010, figure 3, for species attribution of haplotypes). The *C. lupus* haplotypes *C22* and *C23* predominated in Manitoba (25% and 63%, respectively), whereas only *C. lupus* haplotypes *C23* and *16* were observed in wolves from Prince Albert National Park, Saskatchewan (17% and 83%, respectively). This study provided further definition to eastern wolf range; the authors concluded that the western range of eastern wolves did not extend to Saskatchewan (Table 5 of this paper).

In a previous study of Alaskan wolves, Weckworth et al. (2005) found that coastal and continental groups were distinguished by significant differences in allele frequencies at autosomal microsatellite loci, a criterion used to identify management units for conservation (Moritz 1994). Additional criteria are the exhibition of significant differences in mtDNA haplotype frequency for management units or reciprocal monophyly in the inheritance of mtDNA variants by the members of an evolutionarily significant unit. To test for compliance under these criteria, Weckworth et al. (2010) evaluated the mtDNA of the same individuals characterized in their earlier study. Haplotype variation was assessed in coastal southeast Alaska wolves ($n = 129$), coastal Gulf of Alaska wolves ($n = 73$), and wolves from interior localities in Alaska ($n = 64$), Yukon ($n = 12$), and British Columbia ($n = 24$). Although the mtDNA haplotypes identified in this study comprised a portion of the cytochrome *b* gene, tRNAs for proline and threonine, as well as the control region, only the control-region portion was used in this review. The authors observed a pronounced differentiation in mtDNA control-region sequence variation between coastal wolves in the southeast archipelago of Alaska and coastal wolves from the Kenai Peninsula and Copper River delta in the Gulf of Alaska. Similar differences were found in comparisons to populations in interior Alaska and British Columbia. Although genetic differentiation among all localities was significant, differentiation between coastal and inland populations was greatest

and haplotype frequency and composition among coastal wolves was unique. As evidence, haplotype *H* (Weckworth et al. 2010), also known as *lu68* (Muñoz-Fuentes et al. 2009, 2010), is unique to southeast Alaska and coastal British Columbia (Table 5 of this paper). The authors attributed this distinction to independent evolutionary histories for coastal and continental wolves in North America.

Summary of studies of mtDNA. The initial interpretation of mtDNA variation in the Great Lakes region as resulting from coyote–wolf introgression (Lehman et al. 1991) was reinterpreted by Wilson et al. (2000) and later studies (Fain et al. 2010; Wheeldon et al. 2010) as the result of gray wolf–eastern wolf hybridization. Regardless of disagreements over the identity of the taxa involved, there is general agreement that there was a unique historical wolf population in the Great Lakes region that has subsequently been affected by hybridization (Wilson et al. 2000, 2003; Leonard and Wayne 2008; Koblmüller et al. 2009a; Fain et al. 2010; Wheeldon et al. 2010). Surviving red wolves all have a unique mtDNA control-region haplotype that is most similar to those of coyotes, but distinct from eastern wolves (Wilson et al. 2000, 2003; Adams et al. 2003; Hailer and Leonard 2008; Leonard and Wayne 2008; Fain et al. 2010).

There is agreement on the phylogenetic uniqueness of the mtDNA control-region haplotypes of historical and contemporary Mexican wolves (Vilà et al. 1999; Leonard et al. 2005). Moreover, other regional wolf populations that have been attributed taxonomic distinction due to their morphological uniqueness also exhibit corresponding phylogenetically related mtDNA haplotypes (Table 3): coastal Pacific Northwest (*C. l. nubilus*), Alaska–western Canada (*C. l. occidentalis*), and Great Lakes–eastern Canada (*C. l. lycaon* or *C. lycaon*). Regrettably, 5 *C. l. nubilus*-like and 3 *C. l. baileyi*-like haplotypes observed in historical wolves from the Great Plains and southwestern states have been lost due to the extirpation of wolves from the continental United States (Leonard et al. 2005).

Y-chromosome haplotypes

In a study designed primarily to explore the pack composition of wolves in Algonquin Provincial Park, Grewal et al. (2004) reported on Y-chromosome microsatellite haplotype variation among wolves ($n = 248$) at various locations in Ontario and Quebec. Haplotypes were developed for the Y-linked microsatellite loci *MS1A*, *MS1B*, *MS3A*, *MS3B* characterized by Olivier et al. (1999). Sixteen different haplotypes were identified, but species assignments were not made for any of the observed haplotypes. Four to eight haplotypes were observed in each of the six locality samples. No haplotype was common to all localities, but the haplotypes *AA* and *CE* were each found at five localities. Seven

haplotypes were specific to single localities. Consistent with the separation of *C. l. nubilus* and *C. l. lycaon* range (Nowak 1995), differentiation between wolf populations from northern (i.e., northeastern Ontario, Abitibi–Temiscamingue Region, La Verendrye Reserve) and southern (i.e., Algonquin Provincial Park, Frontenac Axis, Magnetawan Region) localities was high (Φ_{ST} ranged 0.111–0.325), while differentiation of wolves from within the respective regions was low (Φ_{ST} ranged -0.057 – 0.073).

Bannasch et al. (2005) used paternally inherited Y-chromosome haplotypes from the Y-linked microsatellite loci *MS34A*, *MS34B*, and *MS41B* (Olivier et al. 1999), and *650-79.2*, *650-79.3*, and *990-35* described in their own study, to evaluate the genetic structure of purebred dogs. A total of 824 unrelated male domestic dogs from 50 different breeds were analyzed. Sixty-seven different haplotypes were observed and many provided genetic distinction between breeds. Twenty-six breeds exhibited breed-specific haplotypes, which indicated lengthy independent histories. Y-chromosome haplotype sharing among several breeds reflected a shared origin, and many of these relationships were confirmed by known breed histories. Neither wolves nor coyotes were included in this study.

Sundqvist et al. (2006) characterized Y-chromosome haplotype variation in a study of the origin of domestic dog breeds. Four Y-linked microsatellite loci (Olivier et al. 1999) were analyzed in wild gray wolves from Alaska ($n = 12$) and Northwest Territories ($n = 13$). Eleven different haplotypes were observed, only one of which (*H32*) was found in both samples (Table 6 in this paper).

Musiani et al. (2007) analyzed Y-chromosome haplotype variation in male gray wolves from boreal forest ($n = 32$) and tundra–taiga ($n = 170$) habitat in Alberta and Northwest Territories, Canada ($n = 202$). Four Y-linked microsatellite loci (Olivier et al. 1999) were analyzed, 19 different haplotypes were observed, and 9 occurred in $>5\%$ of the sample (Table 6 in this paper). Although haplotype frequencies differed between habitat types, genetic differentiation ($F_{ST} = 0.03$) was not significant between male boreal forest and tundra–taiga wolves, contrary to the significant differentiation in mtDNA ($F_{ST} = 0.28$) observed between habitat types. In addition, Y-chromosome gene diversity was similar in wolves from boreal forest and tundra–taiga habitat (i.e., 0.897 and 0.891, respectively). In contrast to results obtained in this study from mtDNA control-region sequence and autosomal microsatellite variation (discussed in previous sections), the Y-chromosome haplotype data did not support the characterization of boreal forest and tundra–taiga wolves as separate populations.

Hailer and Leonard (2008) assessed cross-species introgression in red wolf, Mexican wolf, and Texas coyotes using Y-chromosome microsatellite haplotypes

from four Y-linked microsatellite loci (Olivier et al. 1999) as species markers. The sample included male wolves from the captive-breeding programs for *C. l. baileyi* ($n = 16$) and *C. rufus* ($n = 5$), as well as male *C. latrans* from Texas ($n = 34$) and Nebraska ($n = 36$). These were compared with each other and with similarly characterized reference gray wolves ($n = 226$) from previously published studies (Sundqvist et al. 2001, 2006; Musiani et al. 2007). Two different Y-haplotypes were identified among *C. rufus*: the coyote-like type *H15* that was also observed in 6% of the Texas coyote sample, and *H1* that the authors recognized as wolf-like and most similar to haplotypes *H28* and *H29* found in captive Mexican wolves (Hailer and Leonard 2008, figure 3). They suggested that hybridization with Mexican wolves may have been the route by which this marker entered Texas red wolves. Haplotype *H28* was also found in wolves from Alaska (equals haplotype *G*; Table 6), but both *H1* and *H29* were unique among wolves (Table 6 in this paper) and coyotes.

Fifty-nine unique Y-chromosome haplotypes were identified in the Texas and Nebraska coyote samples, but only three haplotypes were common to both samples. A single Texas coyote exhibited haplotype *H2*, which was phylogenetically most similar to gray wolf haplotype *H44* (Hailer and Leonard 2008, figure 3). Although this haplotype was also found in a Northwest Territories wolf (Musiani et al. 2007), it may also have been present in historical wolves through their southern range. The authors suggest that introgression between Mexican wolves and coyotes may have been the route by which this marker entered the Texas coyote population.

Kobl Müller et al. (2009a) also studied Y-chromosome haplotype variation in wolves of the Great Lakes region. Y-chromosome haplotypes from the four Y-linked microsatellite loci characterized by Olivier et al. (1999) and *650-79.3* and *990-35* characterized by Bannasch et al. (2005) were analyzed in male gray wolves ($n = 30$) and Great Lakes wolves ($n_{\text{Modern}} = 111$, $n_{\text{Historic}} = 4$). The autosomal microsatellite and mtDNA sequence data also obtained in this study are discussed in preceding sections. It was not possible to determine from the presented information how the observed haplotype frequencies were distributed across the different collection localities in the study (i.e., Minnesota, Wisconsin, and Michigan, United States, and Northwest Territories, Alberta, Ontario, and Quebec, Canada).

Seventeen different haplotypes were observed in the western gray wolf sample, and 41 in the Great Lakes wolf sample, with 9 haplotypes common to both samples (Kobl Müller et al. 2009a, table 2). None of these haplotypes was named, nor did the authors provide size information about the alleles

from which the haplotypes were compiled. As a result, it was not possible to equate the Y-chromosome haplotypes identified by Koblmüller et al. (2009a) with those identified in other similar studies (Table 6 in this paper). A median-joining network of Y-chromosome haplotypes identified a major divide between coyote and wolf clades. Nearly all coyotes were found in the coyote clade and all western wolves occurred in the wolf clade, but haplotypes of Great Lakes wolves were distributed among both clades. The four historical Great Lakes wolves for which Y-chromosome haplotypes were determined were all from the Upper Peninsula of Michigan (J. Leonard, Uppsala University, personal communication). The analysis placed all of these specimens in the wolf clade, which suggests that *C. lupus* was interbreeding with Great Lakes wolves prior to their near-extirpation (also see Wheeldon and White 2009; Rutledge et al. 2010a).

Rutledge et al. (2010b) tested the hypothesis that eastern wolves have mediated gene flow between gray wolves and coyotes in the region of Algonquin Provincial Park, Ontario. Y-chromosome microsatellite haplotypes were developed from four Y-linked microsatellite loci (Olivieri et al. 1999) for wolves from northeastern Ontario ($n = 26$), Algonquin Provincial Park ($n = 53$), and Frontenac Axis ($n = 19$). The autosomal microsatellite and mtDNA sequence data also obtained in this study are discussed in preceding sections. The frequency and composition of the Y-chromosome haplotypes observed were consistent with the observations of Grewal et al. (2004, table 2) for wolves in Algonquin Provincial Park (Rutledge et al. 2010b, table 4). The authors used the species assignment method of Shami (2002) to describe the observed haplotypes. *C. lupus* Y-chromosome haplotypes occurred at high frequency in northeastern Ontario (96%) and moderate frequency among Algonquin Provincial Park (17%) and Frontenac Axis wolves (21%). *C. lycaon* Y-chromosome haplotypes were common in both Algonquin Provincial Park (75%) and Frontenac Axis (47%), but only one wolf from northeastern Ontario (4%) exhibited a *C. lycaon* Y-chromosome haplotype. Breeding males at Algonquin Provincial Park had the highest representation (88.9%) of *C. lycaon* haplotypes. *C. latrans* haplotypes were common in the Frontenac Axis sample (32%), rare in Algonquin Provincial Park wolves (8%), and were absent among northeastern Ontario wolves. Similar to the results from mtDNA comparisons, the Y-chromosome results also agreed with the separation of *C. l. nubilus* and *C. l. lycaon* range, which occurred along a transect from the juncture of Lake Superior and Lake Huron eastward to the Quebec border (Nowak 1995). Y-chromosome haplotypes of *C. lupus* origin were five-fold more frequent in northeastern Ontario than to the south, where *C. lycaon* haplotypes predominated.

Fain et al. (2010) analyzed Y-chromosome and mtDNA haplotypes in addition to autosomal microsatellite variation to evaluate various genetic aspects of the recovered wolf population in the western Great Lakes states. Chief among these was their species distinction. The mtDNA and autosomal microsatellite data are discussed in preceding sections. The Y-chromosome-linked microsatellite loci characterized by Olivier et al. (1999) and 650-79.2A, 650-79.2B, and 990-35 characterized by Bannasch et al. (2005) identified species-specific Y-chromosome haplotypes in wolves and coyotes from Minnesota, Wisconsin, and Michigan (Upper Peninsula). Haplotypes were designated as being of either *C. lupus* or *C. lycaon*-*C. latrans* origin after the allele sizing method of Hailer and Leonard (2008). In the combined sample of male western Great Lakes states wolves ($n = 61$), half exhibited unique *C. lycaon* haplotypes and the other half exhibited *C. lupus* haplotypes (Fain et al. 2010, table 1). A median-joining network identified a major divide between coyote and wolf haplotypes (Fain et al. 2010, figure 4, which is reproduced here as Figure 7). The 30 coyote Y-haplotypes observed were all in their own clade, the 14 *C. lupus* Y-haplotypes were placed together in a second clade, and the 5 Y-haplotypes unique to Great Lakes wolves were primarily distributed in a third clade intermediate between gray wolves and coyotes. Although Y-haplotype *FWSClyR* was placed in the coyote clade, the authors interpreted this to be the result of ancient introgression and that this haplotype was being transmitted as a *C. lycaon* lineage marker. Forty-six percent of male western Great Lakes states wolves displayed both *C. lupus* and *C. lycaon* mtDNA and Y-chromosome lineage markers, and 41% of males exhibited both *C. lycaon* mtDNA and Y-chromosome haplotypes, but only 13% exhibited both *C. lupus* mtDNA and Y-chromosome haplotypes. The authors concluded that the western Great Lakes states wolf population was composed of gray wolves (*C. lupus*), eastern wolves (*C. lycaon*), and their hybrids. Moreover, the *C. lupus*- and *C. lycaon*-derived mtDNA and Y-chromosome haplotypes observed in western Great Lakes states wolves were exclusive of *C. latrans* and inconsistent with ongoing hybridization with coyotes.

Wheeldon et al. (2010) evaluated species distinction among the wolves and coyotes of the western Great Lakes region. They investigated Y-chromosome haplotypes based on four Y-chromosome-linked microsatellite DNA loci (Olivieri et al. 1999) in 209 male wolves and coyotes from the western Great Lakes states (Minnesota, Michigan, and Wisconsin) and western Ontario (Table 6 in this paper). Haplotypes were designated as being of either gray wolf or coyote-eastern wolf types after the allele sizing method of Hailer and Leonard (2008); 11 were gray wolf types and 18 were coyote-eastern wolf types.

Two of the 29 haplotypes observed were shared by wolves and coyotes. Forty-four percent of male Great Lakes states wolves displayed both *C. lupus* and coyote–eastern wolf lineage markers. Twenty-nine percent of males exhibited both coyote–eastern wolf mtDNA and Y-chromosome markers, and 27% exhibited both *C. lupus* mtDNA and Y-chromosome markers. The authors concluded that the wolves of the western Great Lakes region are hybrids of gray wolves (*C. lupus*) and eastern wolves (*C. lycaon*). Autosomal microsatellite DNA variation and mtDNA haplotypes from this study were summarized in previous sections.

Summary of studies of Y-chromosome DNA. Y-chromosome microsatellite variation has been studied in wolves to investigate male-mediated gene flow and its effect on population structure (Musiani et al. 2007) and hybridization (Hailer and Leonard 2008; table 4). Y-chromosome microsatellite haplotypes associated with different canid species have been used extensively to study hybridization in the Great Lakes region of the United States and Canada. Studies of wolves in the Great Lakes region differ in characterizing eastern wolf Y-chromosome haplotypes as alternatively *C. lycaon* (Fain et al. 2010; Rutledge et al. 2010a; Wheeldon et al. 2010), Great Lakes wolf (Koblmüller et al. 2009a), or coyote (Koblmüller et al. 2009a). Curiously, these studies also differ in concluding that wolf–coyote hybridization has been rare (Fain et al. 2010; Wheeldon et al. 2010), or that it has occurred recently and is currently ongoing (Koblmüller et al. 2009a). Studies that presented data on both the mtDNA and Y-chromosome haplotypes of individual male wolves of the western Great Lakes region agree that the population consists of gray wolves, eastern wolves, and their hybrids (Fain et al. 2010; Wheeldon et al. 2010). Of the two Y-chromosome haplotypes found in red wolves, one was identical to a haplotype found in Texas coyotes (Hailer and Leonard 2008) while the other was identical to a haplotype found in domestic dogs (Bannasch et al. 2005).

Functional gene loci

Although microsatellite DNA and mtDNA are generally considered to be selectively neutral classes of genetic markers, the loci considered in this section are thought to be subject to natural selection as functional or adaptive genes. These functional genes include loci controlling variation in pelage color and the major histocompatibility complex. Although the canine single-nucleotide polymorphism array data set of vonHoldt et al. (2011) is composed of assessments of thousands of nonneutral functional gene loci, it is discussed separately under the category of “Single-nucleotide polymorphisms.”

Individual wolves with black or melanistic pelage have been reported throughout much of North

America. Schreber’s illustration of the type of *C. lycaon* portrays a black animal, and Goldman (1937) has noted that Buffon’s description, upon which Schreber relied, referred to the animal as a “loup noir.” Bartram (1791) described wolves of northern Florida as black, and called them “*lupus niger*.” Wolves that occurred in this area are now assigned to *C. rufus* (Nowak 1979). The nomenclatural standing of these names is discussed in the present paper in the section on taxonomic background. Richardson (1829) observed that black variants of *C. occidentalis* occurred on the banks of the Mackenzie River, but were more common to the south.

Goldman (1944) reported that “black color phase” individuals occurred at various frequencies in *C. l. pambasileus*, *C. l. occidentalis*, *C. l. nubilus*, and all three subspecies of *C. rufus*.

Jolicoeur (1959) carried out an analysis of the distribution of coat color variation of *C. lupus* in western Canada, along with his morphometric analyses of skull features, which is described earlier in the discussion of morphological studies. He found general patterns of the incidence of pale pelage increasing toward the Arctic.

Mech and Frenzel (1971) suggested that some wolves in northeastern Minnesota were *C. l. nubilus* based on color forms of black and white that Goldman (1944) had reported as common for *C. l. nubilus* but not for eastern wolf.

Kolenosky and Standfield (1975) studied pelage color ($n = 1404$) of two types of wolves from within the Ontario range of *C. l. lycaon* (as broadly defined by Goldman [1944]). The samples included 105 “boreal-type” (from areas of boreal forests) wolves and 122 “Algonquin-type” wolves (from deciduous forest regions). Their accompanying morphometric study of skulls from wolves in this region was described previously in the section on morphology. Coat colors of Algonquin-type individuals were nearly all gray-faun, while boreal-type were mostly gray-faun, but many individuals were black or cream. They suggested that the size and color of boreal-type individuals were more like *C. l. nubilus*, and that the two Ontario forms may not be interbreeding. They associated these types of wolves with different ungulate prey species, with the larger boreal-type wolves preying on moose and caribou, and the Algonquin-type wolves on white-tailed deer.

Anderson et al. (2009) determined that melanism in certain *C. lupus* of western Canada and Yellowstone National Park is controlled by the β -Defensin locus *CBD103*, in contrast to variation at the loci for melanocortin-1 receptor (*Mclr*) and agouti signaling protein (*ASIP*), which control pigmentation in a variety of other vertebrates (Hubbard et al. 2010). Based on coalescence analysis, they propose that K^B , the allele responsible for melanism in these wolves,

was derived from dogs. There is a higher incidence of the K^B allele among wolves in forested habitats, and the authors propose that it provides a selective advantage in forested areas.

In a comment on the study of Anderson et al. (2009), Rutledge et al. (2009) suggested that the K^B allele at locus *CBD103* may have been acquired by *C. lupus* by introgression from black wolves of eastern North America, which include *C. lycaon* and *C. rufus* (= *C. niger*). This suggestion was based on the presence of the K^B allele in coyotes only in eastern North America where hybridization between eastern wolves and coyotes has taken place. In a response to this comment, Barsh et al. (2009) indicated that they remained convinced that the K^B allele was older in dogs than in *C. lupus*, and that dogs also may be responsible for black pelage in eastern wolves. It is not known whether the K^B allele is responsible for melanism in wolves outside of the geographic areas in Alberta, Northwest Territories, and Wyoming, where it was studied by Anderson et al. (2009). In all areas where melanism has been reported, it appears to represent polymorphism within populations, and according to Anderson et al. (2009), introgression of the K^B allele from dogs to wolves was exclusive to North America.

Hedrick et al. (2000) compared variation in the *DRB1*, a class II gene of the major histocompatibility complex, among Mexican wolves and red wolves from the respective recovery programs and among

western coyotes. Major histocompatibility complex is important for immune responses and disease resistance. They found that Mexican wolves did not share alleles with red wolves or California coyotes, but one allele in the Aragon lineage of Mexican wolves was shared with other gray wolves (Hedrick et al. 2000). Red wolves shared one of their alleles with gray wolves. Hedrick et al. (2000) attributed the sharing of alleles among different closely related species to balancing selection that has maintained variation in this gene within populations long after the speciation events.

Further study of major histocompatibility complex variation with additional coyote samples (Hedrick et al. 2002) found that three of the four red wolf haplotypes were shared with coyotes, consistent with their recent history of coyote hybridization prior to the establishment of the captive population (Wayne and Jenks 1991).

Kennedy et al. (2007) reported variation in major histocompatibility complex class II loci in 175 gray wolves from Alaska, Northwest Territories, and Yukon Territory, and compared *DRB1* locus sequences with those of Mexican wolf (Hedrick et al. 2000), red wolf (Hedrick et al. 2002), and coyote. Mexican wolves shared three of five alleles with the northern gray wolves, and none with coyotes. Of the four red wolf alleles, one was shared only with gray wolves, one was shared with both gray wolves and coyotes, and two were unique to red wolves.

The North American Fauna series includes original monographs of scientific investigations relating to North American vertebrates, invertebrates, and plants including descriptions of groups of taxa, ecosystems, or complex interactions among species and basic research on species life history, distribution, population dynamics and taxonomy. It is a continuation by the Fish and Wildlife Service of the series begun in 1889 by the Division of the Ornithology and Mammalogy (U.S. Department of Agriculture) and continued by succeeding Bureaus – Biology Survey and the Bureau of Sports Fisheries and Wildlife – until 1991 when print publication ceased. All succeeding issues in 2010 and beyond are exclusively in electronic format and available at <http://www.fws.gov/journals>.