

1-4-91  
E5901

NASA Technical Memorandum 103683

# An AD100 Implementation of a Real-Time STOVL Aircraft Propulsion System

Peter J. Ouzts and Colin K. Drummond  
*Lewis Research Center  
Cleveland, Ohio*

Prepared for the  
4th Annual Conference of the Applied Dynamics International  
Users' Society of the Central/Northeastern Regions  
Warren, Michigan, October 1-2, 1990

**NASA**

# AN AD100 IMPLEMENTATION OF A REAL-TIME STOVL AIRCRAFT PROPULSION SYSTEM

Peter J. Ouzts and Colin K. Drummond

National Aeronautics and Space Administration  
Lewis Research Center  
Cleveland, Ohio 44135

## ABSTRACT

A real-time dynamic model of the propulsion system for a Short Take-Off and Vertical Landing (STOVL) aircraft has been developed for the AD100 simulation environment. The dynamic model was adapted from a FORTRAN based simulation using the dynamic programming capabilities of the AD100 ADSIM simulation language. The dynamic model includes an aerothermal representation of a turbofan jet engine, actuator and sensor models, and a multivariable control system. The AD100 model was tested for agreement with the FORTRAN model and real-time execution performance. The propulsion system model was also linked to an airframe dynamic model to provide an overall STOVL aircraft simulation for the purposes of integrated flight and propulsion control studies. An evaluation of the AD100 system for use as an aircraft simulation environment is included.

## INTRODUCTION

In the quest for enhanced performance military aircraft, many potential high risk technology concepts are considered. A prudent research plan will seek to identify enabling high risk technologies which together will result in the desired performance gains. Pre-development research can then concentrate on investigating the enabling technologies and thereby significantly reduce the overall risk of an actual development program. An example of the enabling technology approach to a potential high risk development program is the supersonic Short Take-Off and Vertical Landing (STOVL) aircraft. Several enabling technologies which will make such an aircraft possible have been identified and are in the process of being investigated under the auspices of an overall NASA Lewis STOVL Propulsion Technology Program.

The case study for this paper is from an ongoing STOVL technology program at NASA-Lewis. This program has involved the proposed E7D aircraft based on a F16 airframe and F110 type engine (see Jenista et.al. [1987]). STOVL capabilities derive from the installation of two ejector augmenters, a ventral nozzle, a reaction control system, and a 2D-CD cruise nozzle; these devices can be thought of as propulsion control effectors. Conventional elevons and rudders serve as aerodynamic control effectors. The approximate aircraft configuration is shown in Figure 1.



One of the enabling technologies associated with STOVL aircraft is integrated flight and propulsion controls (IFPC). STOVL aircraft require a higher level of controls integration than the usual approach to aircraft control, the latter traditionally consisting of separately designed flight and propulsion control systems. The potential benefits of such an integrated controls approach are improved overall system performance and reduced pilot workload. The overall objective of the NASA STOVL IFPC Program is to define and develop integrated control technologies for achieving STOVL flight-propulsion controls integration. The approach of this program uses cooperative design, simulation, and experimental facilities of NASA aircraft and propulsion research centers to jointly develop, evaluate, and validate STOVL IFPC concepts.

An essential element of the NASA STOVL Technology program is the development of real-time models of STOVL aircraft configurations and propulsion systems. These dynamic models reflect the results of the aircraft configuration design effort and the integrated controls design process. Ultimately, the models are used to conduct performance evaluations of integrated control system concepts on the NASA Ames Vertical Motion Simulator (VMS). Additional experimental evaluations may also be conducted on hardware associated with particular airframe and propulsion concepts. The results and recommendations from these evaluations form the basis of the enabling technology research. NASA facilities in which the above research is conducted are shown on Figure 2.

### **Propulsion System Simulation Environment**

A central element in the propulsion system simulation hardware environment is the Applied Dynamics International System 100 computer, referred to as the AD100. The AD100 is a multi-processor digital computer specifically designed for high-speed simulation of continuous dynamic systems. Figure 3 illustrates the communication paths between the two AD100 simulation computers at NASA Lewis. Although the propulsion system model discussed here resides on a single AD100, future work may involve the other AD100 for airframe models. A flight evaluation station which comprises full screen visual display and cockpit hardware has been added to the Lewis simulation system and will be later linked to the AD100 to provide piloted simulation capabilities. A more detailed description of the NASA Lewis simulation system is given by Bright(1990).

### **Scope of Work**

This paper is not primarily concerned with a particular STOVL aircraft configuration or the integrated controls research programs associated with this aircraft configuration. It instead concentrates on the task of developing a real-time propulsion system model for a given computer hardware environment. The purpose of the paper is to expose, via a case study for a STOVL propulsion system, the issues pertinent in formulating highly complex dynamic real time models for simulation use in the AD100 environment. Since the development of the aerothermal physics model of a turbofan jet engine for the AD100 has been discussed previously (Drummond and Ouzts, 1989), this paper focuses on the

completion of the modelling process to include the propulsion control system and additional dynamic elements (i.e., control actuators and sensors) which form the overall propulsion system model. The performance of the propulsion system model (in terms of validation against the baseline FORTRAN model) will be discussed, as well as computing performance measures such as execution speed and code size. Finally, comments on the use of the AD100 as a simulation computer for a large scale aircraft simulation task will be given.

## REAL-TIME PROPULSION SYSTEM MODEL DEVELOPMENT

A block diagram of the propulsion system model and its relation to the overall STOVL aircraft simulation system is shown on Figure 4. As shown, the major elements of this model are the propulsion control, control actuators, aerothermal turbofan engine model, and sensors. Note that dynamic models of all the above propulsion system components exist in different simulation environments (e.g., FORTRAN systems); however, many of these models are not currently capable of real-time execution on their respective computer hardware.

The challenge in this work was to adapt the simulation models to the AD100 system such that real-time simulation of a STOVL propulsion system was possible. Also note that the propulsion system model must ultimately be linked to an airframe model and additional (and significant) simulation overhead modules (e.g., I/O modules to visual system, cockpit hardware, etc.) to complete the overall simulation system. Therefore, real-time execution of the propulsion system model is not sufficient for this application; the propulsion system must execute *many* times faster than real-time to allow for *overall* system real-time simulation.

Execution speed was the primary reason that the ADI System 100 computer was designated for the E7D/F110 integrated controls simulation task. To achieve the fastest execution speed for the propulsion system model, the philosophy of the programming task was to place as much code as possible in the Dynamic Continuous region of the ADSIM computer language and use as many of the intrinsic functions and capabilities of the ADSIM language as possible. Note that this philosophy resulted in several significant restrictions whose impact on the programming task will be discussed later in this work. What follows here are descriptions of the modelling of elements shown in Figure 5.

### Propulsion System Control

The purpose of the propulsion system control is to drive the turbofan engine to meet engine thrust demands from the aircraft flight control system. Inputs to the propulsion control are engine thrust levels requested by the flight control and environmental conditions indicating the aircraft operating point. Outputs from the propulsion control are commanded actuator positions passed to the control actuators. Sensed engine cycle variables from the



sensor module are used in the propulsion control to compute deviation from the desired thrust levels and to form control errors used in the control logic computations. The control design aspects of the propulsion system control is itself a complex task and will not be discussed here. For the propulsion system control study, a multivariable control system with multiple engine protection loops was implemented. In addition, controller gain scheduling involved multivariate maps to account for changing engine operating conditions (i.e., power level, altitude, Mach number).

Given the highly matrix structure of the propulsion system control for this STOVL application, ADSIM Version 7.0 with its intrinsic matrix functions was installed on the Lewis AD100 systems. The matrix functions provided in V7.0 were used extensively in the programming task. Although the lack of indirect addressing penalizes the use of arrayed variables in ADSIM, the flexibility and "clean" structure resulting from use of matrix functions over simple scalar expressions outweighed the performance loss (i.e., increased execution time) inherent in their use.

The propulsion control included both proportional and integral control paths, therefore, controller state variables were established in the propulsion control model. Because of the variation in integral gains with engine operating condition, the controller states were set as the demanded control actuator values rather than the more common integrated control errors. Demanded control actuator states were expressed in the following form,

$$y_d = K_p(\phi,t)e(t) + \int K_I(\phi,t)e(t)dt \quad (1)$$

where  $\phi$  signifies a functional dependence on engine operating condition. Both continuous and discrete (i.e., next state) state expressions were tested; however, in the final implementation discrete next-state variables were used.

### Actuator Models

Control actuators on the F110/STOVL configured propulsion system consist of the following:

- (1) Fuel valves for main combustor and reheat fuel flow,
- (2) Nozzle positions for the aft and ventral nozzle areas, and
- (3) Butterfly valve angles for ejector nozzle air flow.

The control actuator model takes the demanded actuator positions from the propulsion control model and outputs actual physical values (i.e., lbm/hr fuel flow, sq. in. nozzle area) - these values correspond to the actuator positions in the engine model.

Detailed transfer function models for control actuators are typically higher order expressions. For this application simple transfer functions of the form,

$$x_a = \frac{x_d}{\tau s + 1} \quad (2)$$

were implemented for actuator dynamics. Continuous actuator states were used with both actuator commanded rate and final position limits present. For the actuator position integration the ADSIM intrinsic LIMIT\_INTEGration function was used. Mathematical underflows using this function were experienced when actuator demands were consistently zero (e.g., closed ventral nozzle area). To alleviate this condition, nozzle area actuator lower limits were set at a nominal level (1E-6) vice absolute zero. The small excursions above the high actuator limits which can occur using the LIMIT\_INTEGration function did not cause problems.

There was an additional dynamic element in the main fuel flow path which required modelling. This involved a fuel transport delay corresponding to the distance from the fuel valve to the combustor fuel nozzle. Although a transport delay model is available in ADSIM form, this model was deemed too complex for this application. Instead, the Pade time delay approximation transfer function

$$w_a = w_d \frac{1 - \frac{\tau s}{2}}{1 + \frac{\tau s}{2}} \quad (3)$$

was explored. However, due to the initialization of the LEAD\_LAG function in ADSIM, this resulted in large opposite sign initial values when a non-zero initial condition was present (the non-zero initial condition is always present in fuel flow). In light of this problem, the final solution was the use of a simple multiple next-state approximation for the transport delay model. While this approach is limited due to the requirement of delay time being a multiple of the model step time, it was the simplest and most effective means to implement the appropriate fuel system delay dynamics.

### **Turbofan Engine Model**

A highly detailed turbofan engine model was necessary in order to provide the required propulsion system accuracy for the F110/STOVL configured turbofan engine. Details of the physics involved in this model have been discussed previously (Drummond and Ouzts, 1989) so are not repeated here, though it is important to note the turbofan engine was represented by an eleven state, full envelope, non-linear dynamic model. Mechanical, thermal, and aerodynamic energies were all dynamically modelled. Inputs and outputs of the engine model are shown in Figure 5. All state calculations are the result of aerothermal expressions for the individual component on the engine.



A problem inherent to the traditional method of dynamic modelling of a turbofan engine was encountered in the adaptation of the engine model to the AD100 system. The dynamic model of a turbofan engine model is fundamentally an initial value problem. Functionally, an initial value dynamic problem can be expressed in the form,

$$\dot{x} = f(x, u, t, x_0, u_0) \quad (4)$$

$$y = f(x, u, t) \quad (5)$$

where  $u, x,$  and  $y$  are the model inputs, states, and outputs respectively, and  $x_0$  and  $u_0$  are the initial states and inputs. The solution of Eqn.(4) requires that initial states and inputs have to be specified for the system to begin any dynamic transient. However, the aerothermal engine cycle cannot be solved closed form, therefore, an iterative process is used to "initialize" (i.e., determine the initial value of the inputs and states) the model after which the dynamic transient can begin. Due to the restrictions involving procedural and non-procedural code in the ADSIM language this iterative (i.e., looping) process was not allowed. Therefore, initial values states and inputs for the engine model had to be pre-determined for each operating transient.

In an aircraft simulation many initial conditions (flight conditions) are used. Therefore, a significant amount of off-line effort was necessary to determine initial conditions for the desired flight conditions. Additionally, when a new flight condition was desired during the simulation test period, it was not possible online to obtain the required propulsion system initial conditions. A more efficient means of performing the required initialization of the engine model while still properly utilizing the capabilities of the AD100 system must be developed for future STOVL aircraft simulation use.

### Sensor Model

The F110/STOVL configured propulsion system contains a sensor set which is used to ascertain the operating condition of the engine. The sensed engine cycle parameters are used for engine control feedback, cockpit instrumentation, and engine protection purposes. The inputs to the sensor model are the "actual" engine cycle values and the outputs are the "sensed" engine cycle values.

Detailed models of sensor dynamics are also higher order transfer functions. Similar to the dynamic models for the actuators, transfer functions of the form,

$$x_s = \frac{x_a}{\tau s + 1} \quad (6)$$

were implemented for the sensor dynamics. For most sensors the simple ADSIM LAG function was sufficient for the modelling task.

## PROPULSION SYSTEM MODEL PERFORMANCE

Performance of the propulsion system model focused on two simulation characteristics:

1. How well the ADSIM propulsion system model matched the baseline (i.e., truth) FORTRAN propulsion system model, and
2. The computational performance of the model (e.g., execution speed, code size, etc.).

In the first case, performance assessment took the form of a validation exercise. The second required the analysis of real-time simulation runs.

### ADSIM Propulsion Model Validation

The real-time propulsion system model developed in this work had to be validated against a baseline FORTRAN model. This validation involved both individual element validations (i.e., sensor models from both applications), as well as the more important overall system performance. **Significant** modifications to the baseline models had to be made for the real-time ADSIM code development. These modifications were related to the real-time task **and** the AD100 simulation environment.

It is important to note that STOVL aircraft applications place stringent demands on propulsion system dynamic performance. Indeed, the purpose of the NASA-Lewis IFPC studies is to evaluate various control design methodologies for their ability to meet the requirements of a STOVL aircraft application. For this study, the actual propulsion system control design was performed on the baseline FORTRAN model. Due to the high propulsion system bandwidth requirements dictated by the STOVL aircraft application, small dynamic differences between the FORTRAN baseline and the ADSIM adaptation could have serious detrimental effects on overall system performance. Therefore, given the modifications made in the ADSIM real-time adaptation, the validation of the AD100 model to the baseline FORTRAN model was paramount.

The overall system validation process consisted of running a series of propulsion system transients on both the real-time ADSIM and FORTRAN versions of the propulsion system. These tests were extensive; however, only a single example will be shown here. In this example, the propulsion system is commanded by the flight control to move from a slow forward speed transition flight condition (both aerodynamic and propulsive lift) to a full hover condition (all propulsive lift). For the propulsion system this involves a coordinated reduction in aft nozzle thrust (consistent with aerodynamic lift) with corresponding increases in ejector and ventral nozzle thrusts (consistent with propulsive lift). The flight control transient sends the input as a one second ramp in demanded propulsion system thrusts. This transient is a rigorous example of actual piloted commands expected in the overall aircraft simulation.



The results of the example transient are shown on Figure 6. The response of the two models to the commanded input shows good agreement. It is important to note that the performance validation evidenced in Figure 6 resulted from a significant and time consuming effort. The magnitude of the validation effort was directly attributable to the stringent performance validation requirements discussed above and the inability of the AD100 system to efficiently perform the validation effort. A more detailed discussion of the AD100 as a simulation development tool is given below.

### **Simulation System Performance**

The performance evaluation of the ADSIM realtime propulsion system model in terms of the simulation system involved execution speed and code size. Figure 7 gives these values for each module of the propulsion system as well as the overall values for the entire system. Based on a propulsion system integration step size of 10 ms, the AD100 model executes more than seven times real time. Faster than real time execution speed was vital for the overall STOVL aircraft simulation. Note that the propulsion control model is larger and takes longer to execute than the aerothermal engine model. This may be indicative of the large number of matrix operations in the multivariable control.

The overall code size of the propulsion model was relatively small; code size is important given that the propulsion system model is but one piece of an overall STOVL aircraft model which must fit within the overall 64K code size limit of the AD100. ADSIM variables and function table size are well within limits of the AD100 system.

### **REMARKS ON THE SIMULATION EXPERIENCE**

This project was the first use of the AD100 simulation computer by NASA Lewis for a STOVL aircraft simulation. As such, the adaptation of baseline FORTRAN propulsion model to the AD100 was a learning experience. On this basis several significant comments may be made regarding the AD100 environment as a simulation system for this particular type of task.

In terms of final propulsion system model performance, the AD100 performed admirably. The propulsion system model executed many times faster than real-time and code size was well within the machine's limits. However, many deficiencies were identified in the AD100 simulation environment which had significant impact on the simulation task. Paramount among these deficiencies are the tools necessary to function as a simulation code development system.

The use of an AD100 system as a code development machine is hampered by excessive compilation times and lack of a viable debugging tool. Compilation times for the propulsion system model described in this paper using the standard AD100 front-end workstation were over fifteen minutes. Due to the total compilation process of the ADSIM language, even minor typographical errors required full recompilation. The code debugging

tool available on the V7.0 AD100 system provided little assistance in the code development task. The time-consuming efforts made in this task to validate the real-time ADSIM model could have been significantly reduced by a more useful debugging tool (this is mitigated to some extent in V7.1). Furthermore, the use of the ADVAX to perform some development on a more powerful machine (i.e, VAX 8300) was attempted, but this effort was compromised by the differences between ADVAX and ADSIM which were sufficient enough to preclude this path as a viable code development method.

Ideally, the AD100 system may be used as final simulation computer for fully developed simulation code. However, in many real applications, some modifications to "final" simulation code are unavoidable and many times desired. Therefore, adequate tools for code development are important to the AD100 system's overall functionality as a simulation computer.

Finally, it should be noted that the propulsion system model was ultimately linked to an aircraft model on a AD100 system at NASA Ames and an overall STOVL aircraft simulation performed. Details of this simulation experience are not presented here. However, both compilation times and code size were important factors in the simulation. During this exercise compilation times for the simulation code approached one hour. As expected, many changes to the simulation code were made during the simulation period. The excessive compilation times combined with the inability to perform on-line debugging of code compromised the overall simulation effort. The final simulation code size was very close to the 64K limit of the AD100 system. This required both deletion of useful but not necessary code modules and use of multiple loads to accommodate the code size limitations.

## CONCLUSIONS

A real-time dynamic model of the propulsion system for a STOVL aircraft was developed. The model met performance specifications in terms of validation to existing models, execution time and code size. However, drawbacks with the AD100 simulation environment hamper its usefulness as a simulation computer for advanced STOVL aircraft simulation studies.



## NOMENCLATURE

$K$	gain matrix
$s$	transform value
$t$	time
$u$	model input values
$w$	fuel flowrate
$x$	state variable
$y$	output variable
$e$	error
$\tau$	time constant
$\phi$	generalized engine control variable

### Subscripts

$a$	actual
$d$	demanded
$I$	integral
$P$	proportional
$s$	sensed
$0$	initial state

## REFERENCES

1. Bright, M. (1990), "NASA Lewis Integrated Propulsion and Flight Control Simulator," *NASA-TM in-progress*.
2. Drummond, C.K. and Ouzts, P.J. (1989), "Real-Time Simulation of an F110/STOVL Turbofan Engine," *NASA TM-102409*.
3. Jenista, J.E., and Sheridan, A.E. (1987), "Configuration E7 Supersonic STOVL Fighter/Attack Technology Program," *SAE Paper 87-2379*.

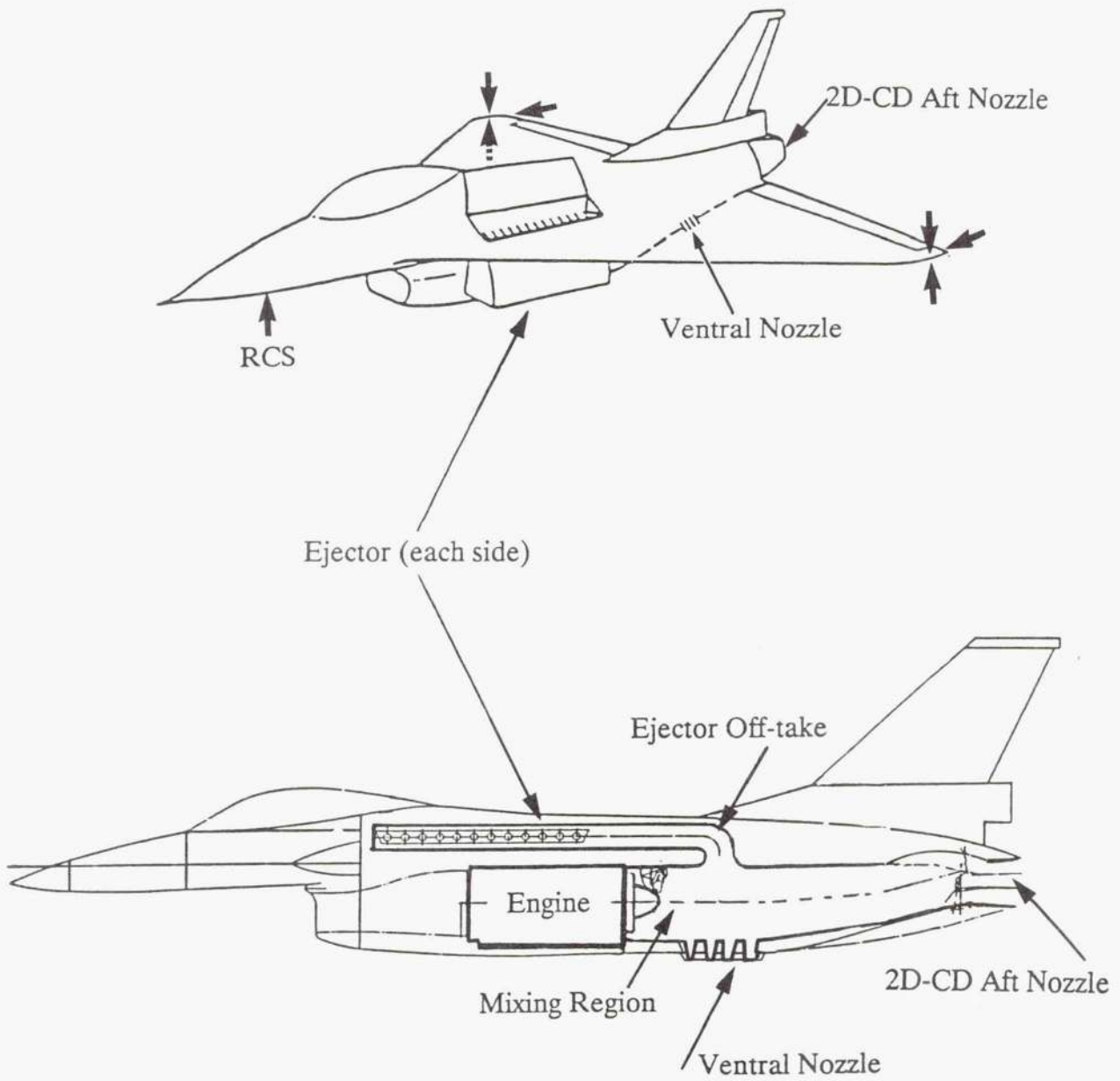

Fig. 1 E-7D/Ejector configured aircraft.



# STOVL INTEGRATED CONTROLS RESEARCH DEMONSTRATOR PROGRAM

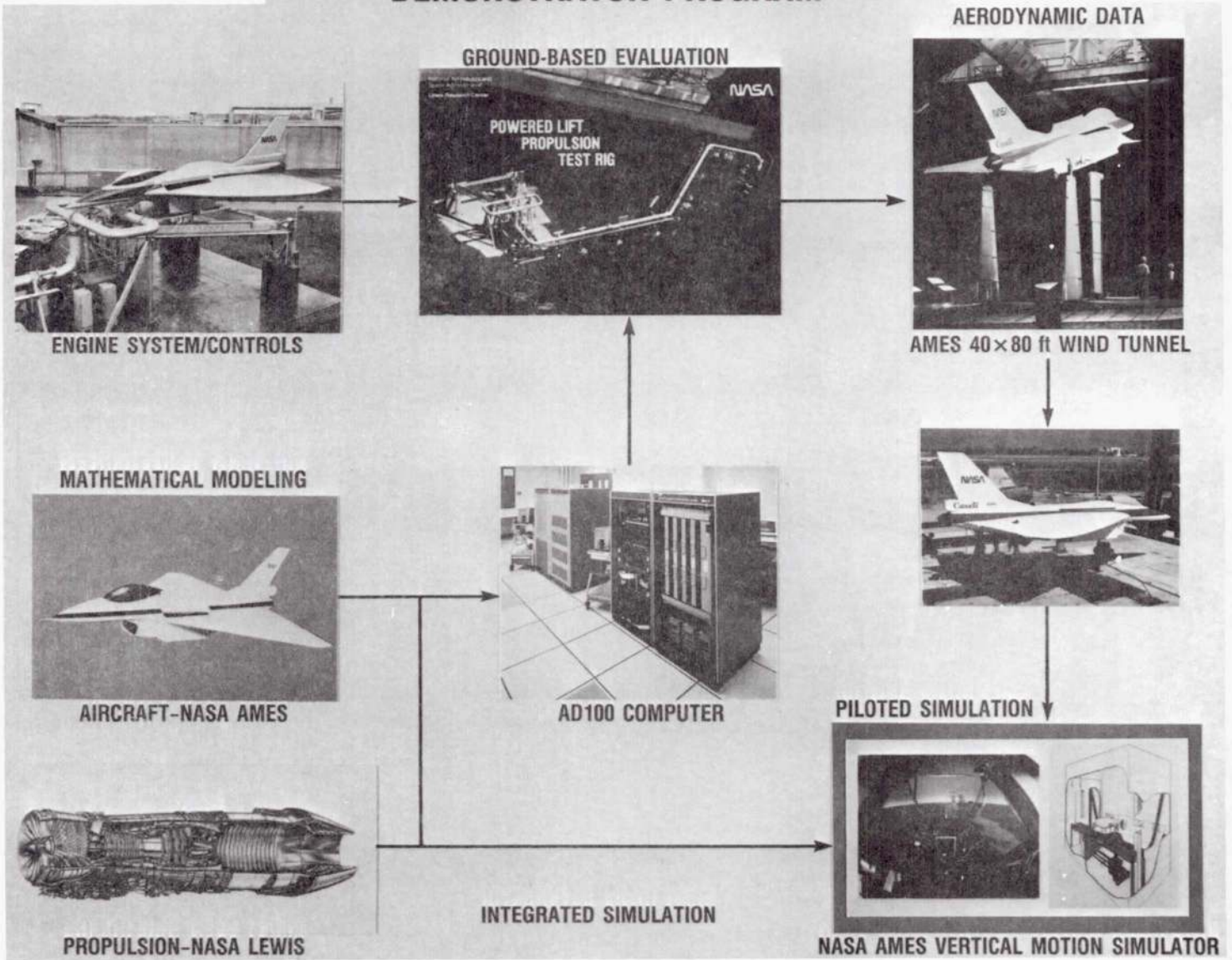
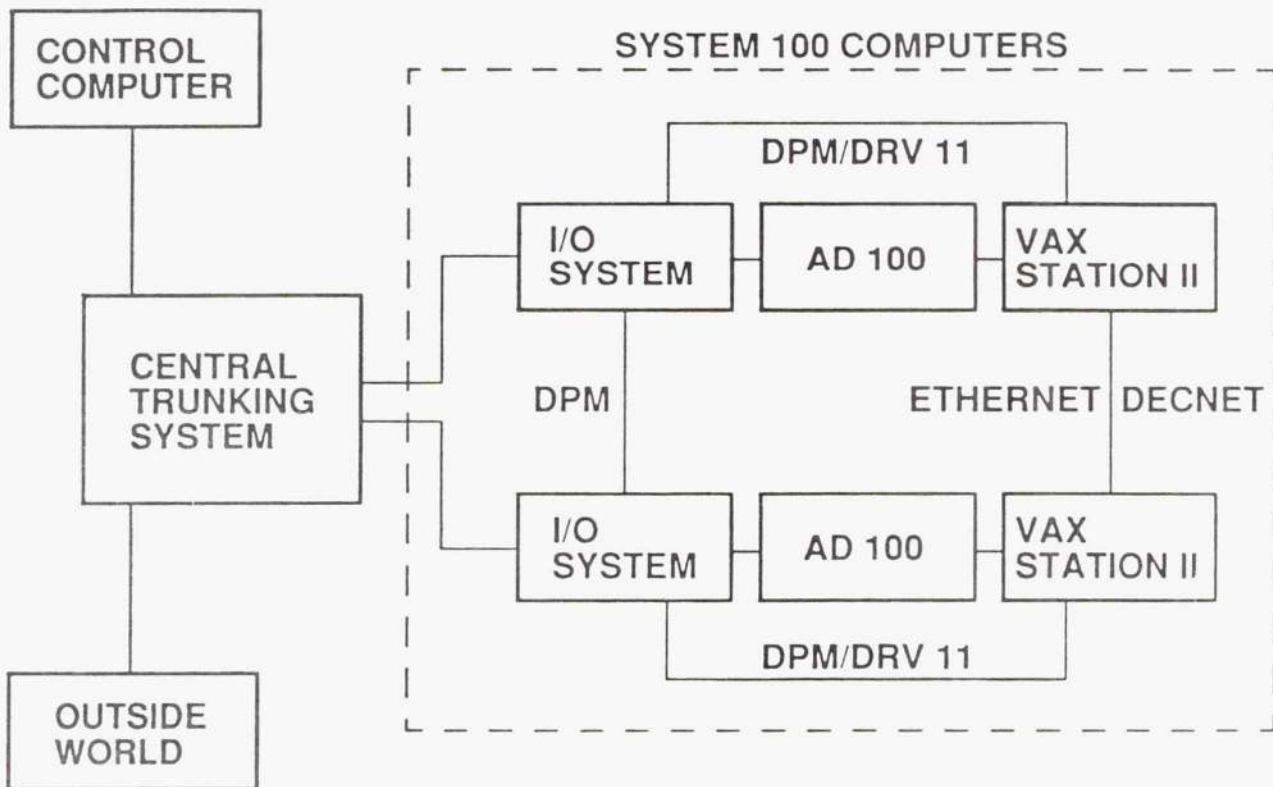

Figure 2. Integrated Controls Research Facilities



CD-89-40939

Figure 3. NASA Lewis System 100 Simulation Computers and Communication Paths



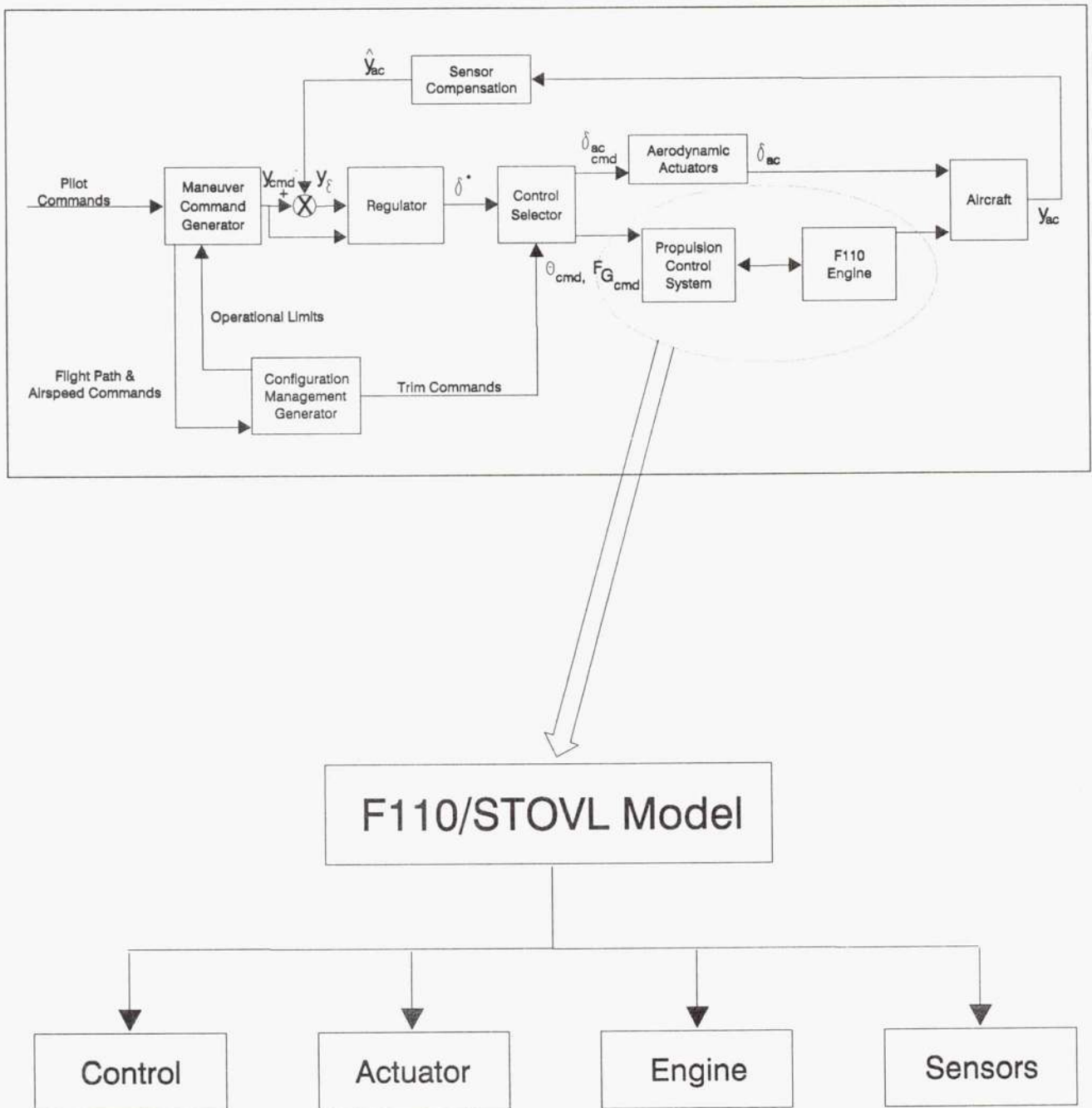

Figure 4. Overall Simulation Structure

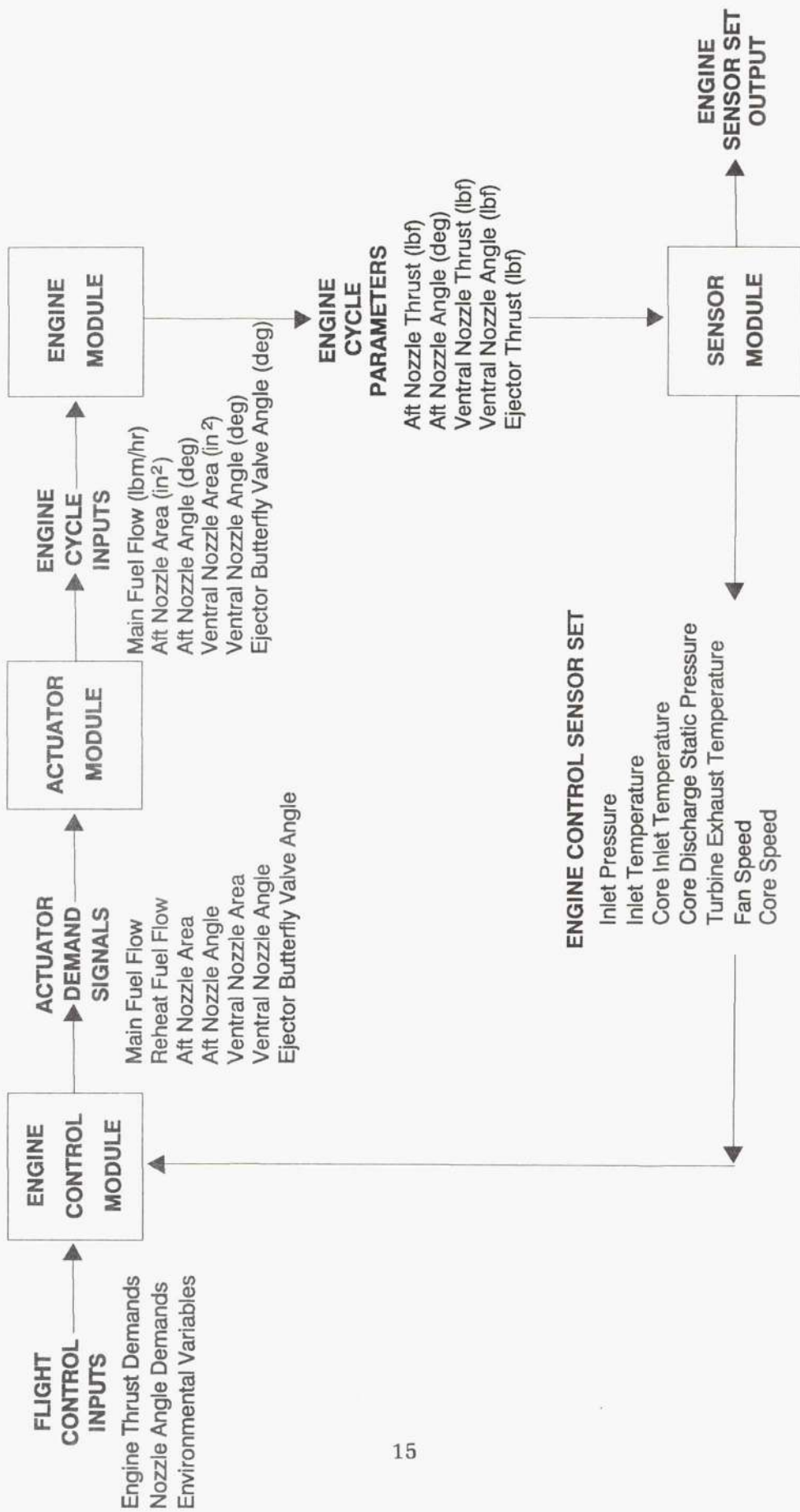

Figure 5. System Simulation Modules



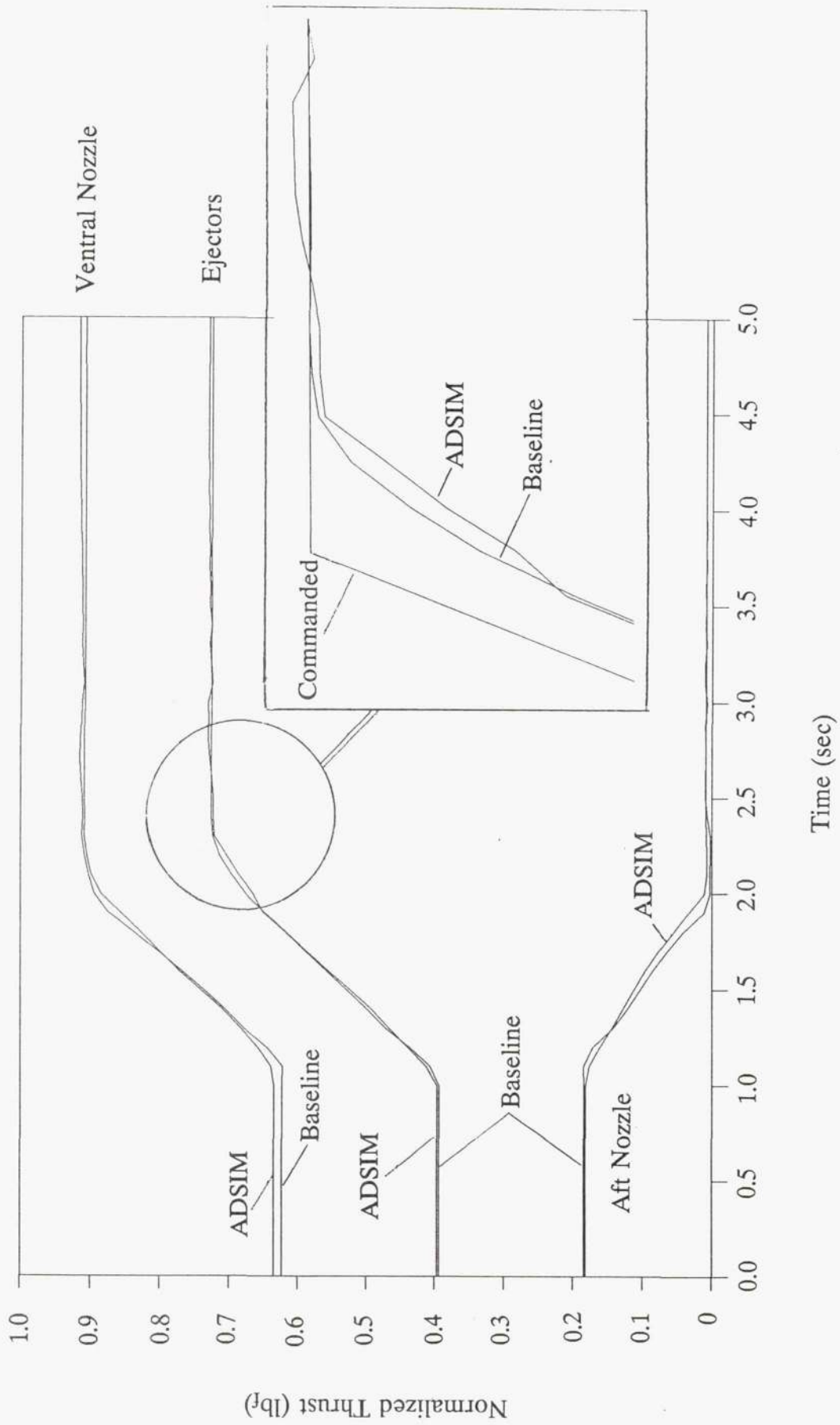

Figure 6. Thrust History for Multiple Effector Operation

CODE MODULE	LINES OF CODE	AD100 MEMORY SIZE (B)			EXECUTION SPEED (msec)
		STO	COM	FMU	
Engine Control	2223	2542	3560	4489	0.6043
Actuator	364	774	958	905	0.0895
Engine	1728	1398	2580	5570	0.4153
Sensor	234	697	603	905	0.0819
<b>TOTAL</b>	<b>4549</b>	<b>3915</b>	<b>6948</b>	<b>9097</b>	<b>1.3954</b>

Figure 7. Simulation System Performance



1. Report No. NASA TM-103683		2. Government Accession No.		3. Recipient's Catalog No.	
4. Title and Subtitle An AD100 Implementation of a Real-Time STOVL Aircraft Propulsion System				5. Report Date	
				6. Performing Organization Code	
7. Author(s) Peter J. Ouzts and Colin K. Drummond				8. Performing Organization Report No. E-5901	
				10. Work Unit No. 505-62-71	
9. Performing Organization Name and Address National Aeronautics and Space Administration Lewis Research Center Cleveland, Ohio 44135-3191				11. Contract or Grant No.	
				13. Type of Report and Period Covered Technical Memorandum	
12. Sponsoring Agency Name and Address National Aeronautics and Space Administration Washington, D.C. 20546-0001				14. Sponsoring Agency Code	
15. Supplementary Notes Prepared for the 4th Annual Conference of the Applied Dynamics International Users' Society of the Central/Northeastern Regions, Warren, Michigan, October 1-2, 1990.					
16. Abstract A real-time dynamic model of the propulsion system for a Short Take-Off and Vertical Landing (STOVL) aircraft has been developed for the AD100 simulation environment. The dynamic model was adapted from a FORTRAN based simulation using the dynamic programming capabilities of the AD100 ADSIM simulation language. The dynamic model includes an aerothermal representation of a turbofan jet engine, actuator and sensor models, and a multivariable control system. The AD100 model was tested for agreement with the FORTRAN model and real-time execution performance. The propulsion system model was also linked to an airframe dynamic model to provide an overall STOVL aircraft simulation for the purposes of integrated flight and propulsion control studies. An evaluation of the AD100 system for use as an aircraft simulation environment is included.					
17. Key Words (Suggested by Author(s)) STOVL Propulsion system Real-time simulation			18. Distribution Statement Unclassified-Unlimited Subject Category 07		
19. Security Classif. (of this report) Unclassified		20. Security Classif. (of this page) Unclassified		21. No. of pages 18	22. Price* A03