

Fig. 10. (a) Write state diagram. (b) Memory-Write controller.

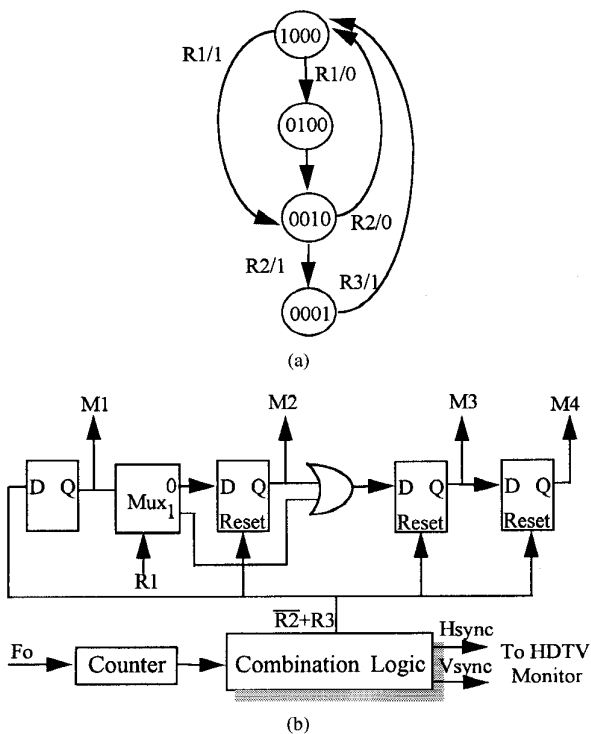

Fig. 11. (a) Read state diagram. (b) Memory-Read controller.

REFERENCES

[1] R. Hopkins, "Digital terrestrial HDTV for North America: The grand alliance HDTV system," *IEEE Trans. Consumer Electron.*, vol. 40, pp. 185-198, Aug. 1994.  
 [2] "Digital spectrum compatible: Technical description," Zenith and AT&T, Feb. 1991.

[3] L. Capodiferro, "Progressive scan conversion by median filtering," *Signal Processing of HDTV*, 1990, pp. 667-684.  
 [4] S. C. Hsia, B. D. Liu, J. F. Yang, and C. H. Huang, "A concurrent video conversion based on uniform interpolation," in *Proc. Int. Workshop on HDTV'95*, Nov. 1995, pp. 8B41-8B48.  
 [5] D. H. Lee, J. S. Park, and Y. G. Kim, "Video format conversions between HDTV systems," *IEEE Trans. Consumer Electron.*, vol. 39, pp. 219-223, Aug. 1993.  
 [6] T. Doyle and M. Looymans, "Progressive scan conversion using edge information," *Signal Processing of HDTV*, 1990, pp. 711-722.  
 [7] J. Jeong and B. Jeon "A multiplierless letter box converter for displaying 16:9 images on 4:3 screen," *IEEE Trans. Circuits Syst. Video Technol.*, vol. 5, pp. 363-366, Aug. 1995.  
 [8] S. C. Hsia, B. D. Liu, J. F. Yang, and B. L. Bai, "VLSI implementation of a parallel coefficient-by-coefficient two-dimensional IDCT processor," *IEEE Trans. Circuits Syst. Video Technol.*, vol. 5, pp. 396-406, Oct. 1995.

An Adaptive Nearest Neighbor Multichannel Filter

K. N. Plataniotis, Vinayagamoorthy Sri,  
 D. Androustos, and A. N. Venetsanopoulos

**Abstract**—This paper addresses the problem of noise attenuation for multichannel data. The proposed filter utilizes adaptively determined data-dependent coefficients based on a novel distance measure which combines vector directional with vector magnitude filtering. The special case of color image processing is studied as an important example of multichannel signal processing.

Manuscript received February 23, 1996; revised August 5, 1996. This paper was recommended by Associate Editor J. Brailean.  
 The authors are with the Department of Electrical and Computer Engineering, University of Toronto, Toronto, ON, M5S 3G4, Canada.  
 Publisher Item Identifier S 1051-8215(96)08989-6.

TABLE I  
NMSE ( $\times 10^{-2}$ ) FOR THE "LENNA" IMAGE, WINDOW  $3 \times 3$

Noise Model	ANNMF	ANNMF2	ANMF	BVDF	GVDF	DDF	VMF
Gaussian ( $\sigma = 30$ )	0.8408	0.8222	0.8516	2.8962	1.46	1.524	1.60
impulsive (4%)	0.2298	0.2348	0.2667	0.3848	0.30	0.3255	0.19
Gaussian ( $\sigma = 15$ ) impulsive (2%)	0.3431	0.3346	0.3785	1.1354	0.6238	0.6483	0.5404
Gaussian ( $\sigma = 30$ ) impulsive (4%)	1.0205	1.014	1.0864	3.8515	1.982	2.1646	1.6791

TABLE II  
NMSE ( $\times 10^{-2}$ ) FOR THE "LENNA" IMAGE, WINDOW  $5 \times 5$

Noise Model	ANNMF	ANNMF2	ANMF	BVDF	GVDF	DDF	VMF
Gaussian ( $\sigma = 30$ )	0.5842	0.578	0.6242	2.8819	1.08	1.0242	1.17
impulsive (4%)	0.3792	0.3885	0.4269	0.7318	0.54	0.5126	0.58
Gaussian ( $\sigma = 15$ ) impulsive (2%)	0.3964	0.3930	0.4367	1.3557	0.459	0.6913	0.5172
Gaussian ( $\sigma = 30$ ) impulsive (4%)	0.697	0.6916	0.7528	4.1237	1.1044	1.3048	1.0377

## I. INTRODUCTION

Vector processing based on order statistics (OS) is one of the most effective methods available to filter out noise in multichannel signals [1]. In multichannel case, however, the concept of vector ordering has more than one interpretation and the center-most vector inside a filter window can be defined in more than one way depending on the distance function selected to measure dissimilarity among multivariate vectors [2]. A number of multichannel filters, such as the vector median filter (VMF) [1] and the vector directional filter (VDF) [3], which utilize correlation among multivariate vectors using distance measures, have been proposed. In this letter, a novel distance criterion to order multivariable vectors is used in conjunction with an adaptive nearest-neighbor filter. The new filter can be viewed as a generalization of the filter introduced in [4] since a more general ordering criterion is introduced.

## II. THE NONLINEAR MULTICHANNEL FILTER

Let  $y(x) : Z^l \rightarrow Z^n$  represent a multichannel signal and let  $W \in Z^l$  be a window of finite size  $n$  (filter length). The noisy vectors inside the window  $W$  are noted as  $x_j$ ,  $j = 1, 2, \dots, n$ . The filter is a weighted average of all input vectors inside the window  $W$ . Therefore, the filter's output at the window center is

$$\hat{y} = \frac{\sum_{j=1}^n w_j x_j}{\sum_{j=1}^n w_j}. \quad (1)$$

Each one of the weights is a function of the distance between the vector under consideration and all other vectors inside the filter window. In this paper, a neighbor weighting function is utilized to assign weights to each one of the vector inputs. The weighting function introduced here is a generalization of the  $k$ -nearest neighbor ( $k$ -NN) rule used in [4]. This function which is used to regulate the contribution of the vector located at pixel  $i$  is defined in the following equation:

$$w_i = 1 \text{ if } d_{(i)} = d_{(1)}, \quad w_i = 0 \text{ if } d_{(i)} = d_{(s)}$$

and

$$w_i = \frac{(d_{(s)} - d_{(i)}) + \alpha(d_{(s)} - d_{(1)})}{(1 + \alpha)(d_{(s)} - d_{(1)})} \quad (2)$$

otherwise where  $d_{(n)}$  is the maximum distance in the filtering window, measured using an appropriate distance criterion,  $d_{(1)}$  is the minimum distance, which is associated with the center most vector

inside the window, and  $s \leq n$  with  $d_{(1)} \leq d_{(2)} \leq \dots \leq d_{(s)} \leq \dots \leq d_{(n)}$ . It easily can be seen that if  $s = n$  and  $\alpha = 0$  the new weighting function is equivalent to that used in [4] and [5]. The regulating parameter  $\alpha$  takes values in the interval  $[0, 1)$ . These values are either fixed, reflecting the designers confidence about the distances among the image vectors, or can be calculated adaptively using the relation  $\alpha = \frac{1}{d_{(s)} - d_{(i)}}$  as proposed in [6].

The value of the weight, above, expresses the degree to which the vector at point  $i$  is close to the ideal, center-most vector, and far away from the worst value, the outer rank. Both the optimal rank position  $d_{(1)}$  and the worst rank  $d_{(n)}$  are occupied by at least one of the vectors under consideration. It is evident that the outcome of the filter depends on the choice of the distance criterion selected as a measure of dissimilarity among vectors.

Many such distance criteria have been used in the past for the development of multichannel filters. Among them, the VMF uses the ( $L_1$ ) norm (*city block distance*) to order vectors according to their relative magnitude differences [1]. The orientation difference between the color vectors is used by the different VDF's to remove vectors with atypical directions. This scalar angle measure

$$d_i = \sum_{j=1}^n A(x_i, x_j) \quad (3)$$

with

$$A(x_i, x_j) = \cos^{-1} \left( \frac{x_i x_j^t}{|x_i| |x_j|} \right) \quad (4)$$

is the distance associated with the noisy vector  $x_i$  inside the processing window of length  $n$  [3]. The adaptive nearest-neighbor filter discussed in [4] uses the same distance measure as well. However, both these distance metrics utilize only part of the information carried by the image vector. It is anticipated that a general purpose filter based on a novel ordering criterion which utilizes both vector features, namely magnitude and direction, will provide a robust solution whenever the noise characteristics are unknown. In this letter, such a measure is introduced. The proposed distance measure for the noisy vector  $x_i$  inside the processing window of length  $n$  is defined as

$$d_i = \sum_{j=1}^n (1 - S(x_i, x_j)) \quad (5)$$

with

$$S(x_i, x_j) = \left( \frac{x_i x_j^t}{|x_i| |x_j|} \right) \left( 1 - \frac{||x_i| - |x_j||}{\max(|x_i|, |x_j|)} \right). \quad (6)$$

TABLE III  
NCD FOR THE "LENNA" IMAGE, 3 × 3

Noise	ANNMF	ANNMF2	ANNF	BVDF	GVDF	DDF	VMF
Gaussian (σ = 30)	0.0185	0.0182	0.0197	0.0438	0.0305	0.0355	0.043
impulsive (4%)	0.0035	0.0037	0.0040	0.0069	0.0069	0.0063	0.0034
Gaussian (σ = 15) impulsive (2%)	0.0074	0.0074	0.0080	0.0179	0.0110	0.0143	0.0153
Gaussian (σ = 30) impulsive (4%)	0.0212	0.0205	0.0231	0.0585	0.0344	0.047	0.048

TABLE IV  
NCD FOR THE "LENNA" IMAGE, 5 × 5

Noise	ANNMF	ANNMF2	ANNF	BVDF	GVDF	DDF	VMF
Gaussian (σ = 30)	0.0110	0.0109	0.0119	0.0345	0.0156	0.0213	0.0268
impulsive (4%)	0.0052	0.0053	0.0051	0.0119	0.0055	0.0059	0.0061
Gaussian (σ = 15) impulsive (2%)	0.0071	0.0072	0.0076	0.0118	0.0081	0.0103	0.0118
Gaussian (σ = 30) impulsive (4%)	0.0128	0.0127	0.0139	0.0567	0.0175	0.023	0.0284

As can be seen, the similarity measure of (6) takes into consideration both the direction and the magnitude of the vector inputs. The first part of the measure in (6) is equivalent to the *vector angle criterion* of (4) and the second part is related to the normalized difference in magnitude. Thus, if the two vectors under consideration have the same length, the second part of (6) is equal to one and only the directional information is used in (6). On the other hand, if the vectors under consideration have the same direction in the vector space (collinear vectors), the first part (directional information) equals one and the similarity measure of (6) is based only on the magnitude difference part.

Utilizing our new similarity measure, the adaptive filter performs smoothing at all vectors which are from the same region as the vector at the window center. It is reasonable to make the weights proportional to the difference, in terms of a distance measure, between a given vector and its neighbors inside the operational window. At edges or in areas with high details, the filter smooths only over pixels at the same side of the edge as the center-most vector, since vectors with relatively large distance values will be assigned smaller weights and will contribute less to the final filter estimate. Thus, edge or line detection operations prior to filtering can be avoided with considerable savings in terms of computational effort.

III. APPLICATION TO COLOR IMAGE PROCESSING

It must be emphasized that the above multichannel vector processing filter is a general filter which can be applied to any type of vector processing problem. As an important example of vector processing, we select the problem of color image processing. In the different color spaces, each pixel of a color image is represented by three values which can be considered as a vector, transforming the color image to a vector field in which each vector's direction and length is related to the pixel's chromatic properties [1]. Thus, a vector processing filter is most appropriate to smooth out noise and preserve edges and details in color image processing. Two members of the proposed adaptive nearest-neighbor multichannel filter family, the ANNMF obtained with  $\alpha = 0$ ,  $n = s$  and the ANNMF2 obtained with  $\alpha = \frac{1}{d_{(n)} - d_{(s)}}$ ,  $n = s$  are compared quantitatively with the widely used VMF, chromaticity-based filters such as the basic vector directional filter (BVDF), the generalized vector directional filter (GVDF) [3], and the directional-distance filter (DDF) [7] introduced lately to overcome the limitations of the VDF's, and finally the adaptive nearest-neighbor filter (ANNF) discussed in [4]. The color RGB test image "Lenna" has been contaminated using



Fig. 1. "Lenna" corrupted with 4% impulsive noise.

various noise source models in order to assess the performance of the filters under different noise distributions. The normalized mean square error (NMSE) has been used as quantitative measure for evaluation purposes. It is computed as

$$NMSE = \frac{\sum_{i=0}^{N1} \sum_{j=0}^{N2} \|(y(i, j) - \hat{y}(i, j))\|^2}{\sum_{i=0}^{N1} \sum_{j=0}^{N2} \|(y(i, j))\|^2} \quad (7)$$

where  $N1, N2$  are the image dimensions, and  $y(i, j)$  and  $\hat{y}(i, j)$  denote the original image vector and the estimation at pixel  $(i, j)$ , respectively. Table I summarizes the results obtained for the test image "Lenna" for a 3 × 3 filter window. The results obtained using a 5 × 5 filter window are given in Table II.

Perceptual closeness (alternatively perceptual difference or error) of the filtered image to the uncorrupted original image is ultimately the best measure of the efficiency of any color image filtering method. Unfortunately, the human perception of color cannot be described using the RGB model. Therefore, measures such as the NMSE defined in the RGB color space cannot quantify well the perceptual error between images. Thus, perceptually uniform color spaces, such as the  $L^*u^*v^*$  and  $L^*a^*b^*$  are most appropriate to define simple yet precise measures of perceptual error [8].

The uniform color space  $L^*a^*b^*$  is chosen for our analysis. In this color space we computed the normalized color difference (NCD)

Fig. 2. ANMF of (1) using  $3 \times 3$  window.Fig. 4. DDF of (1) using  $3 \times 3$  window.Fig. 3. ANNF of (1) using  $3 \times 3$  window.Fig. 5. GVDF of (1) using  $3 \times 3$  window.

which is estimated according to the following formula:

$$NCD = \frac{\sum_{i=0}^{N_1} \sum_{j=0}^{N_2} \|\Delta E_{ab}\|}{\sum_{i=0}^{N_1} \sum_{j=0}^{N_2} \|E_{ab}^*\|} \quad (8)$$

where  $E_{ab}^*$  is the square of *norm* or *magnitude* of the uncorrupted original image pixel vector in the  $L^*a^*b^*$  space and  $\Delta E_{ab}$  is the difference between the original image and the filtered result at the specific image location  $(i, j)$  defined as follows:

$$\Delta E_{ab}(i, j) = (L(i, j) - \hat{L}(i, j))^2 + (a(i, j) - \hat{a}(i, j))^2 + (b(i, j) - \hat{b}(i, j))^2. \quad (9)$$

Tables III–IV summarize the results obtained for the test image “Lenna.”

In addition to the quantitative evaluation presented above, a qualitative evaluation is necessary since the visual assessment of the processed images is, ultimately, the best subjective measure of the efficiency of any method. Therefore, we present sample processing results in Figs. 1–5. Fig. 1 shows the color image “Lenna” corrupted with additive (4%) impulsive noise. Figs. 2–5 present filtering results obtained using the various filters discussed above.

#### IV. CONCLUSION

An adaptive nearest-neighbor filter which utilizes a novel distance criterion to rank vector signals was introduced here. The new criterion takes into consideration both the magnitude and the orientation of the vectors. The proposed filter, when applied to the problem of color image filtering, outperforms other widely used multichannel filters, preserving at the same time the chromaticity components of the color image. Future work in this area should address the development of double-window adaptive nearest-neighbor filters where an outlier rejection scheme will be employed before the adaptive filter.

#### REFERENCES

- [1] A. N. Venetsanopoulos and K. N. Plataniotis, “Multichannel image processing,” in *Proc. IEEE Workshop on Nonlinear Signal/Image Processing*, June 1995, pp. 2–6.
- [2] I. Pitas and A. N. Venetsanopoulos, “Order statistics in digital image processing,” *Proc. IEEE*, vol. 80, pp. 1893–1923, Dec. 1992.
- [3] P. E. Trahanias and A. N. Venetsanopoulos, “Vector directional filters: A new class of multichannel image processing filters,” *IEEE Trans. Image Processing*, vol. 2, no. 4, pp. 528–534, 1993.
- [4] K. N. Plataniotis, D. Androutsos, V. Sri, and A. N. Venetsanopoulos, “A nearest neighbor multichannel filter,” *Electron. Lett.*, pp. 1910–1911, Oct. 1995.

- [5] S. A. Dudani, "The distance-weighted  $k$ -nearest neighbor rule," *IEEE Trans. Systems, Man and Cybernetics*, vol. SMC-15, pp. 630–636, 1977.
- [6] J. M. Keller, M. R. Gray, J. A. Givens, "A re-examination of the distance-weighted  $k$ -nearest neighbor classification rule," *IEEE Trans. on Syst., Man, Cybern.*, vol. SMC-17, pp. 689–697, 1987.
- [7] D. G. Karakos and P. E. Trahanias, "Combining vector median and vector directional filters: The directional-distance filters," in *Proc. IEEE Conf. Image Processing, ICIP-95*, Oct. 1995, pp. 171–174.
- [8] P. G. Engeldrum, "A framework for image quality models," *J. Imaging Sci. Technol.*, vol. 39, no. 4, pp. 312–318, 1995.

## Identification and Minimization of IIR Tap Coefficients for the Cancellation of Complex Multipath in Terrestrial Television

Robert Simon Sherratt

**Abstract**—By using a deterministic approach, an exact form for the synchronous detected video signal under a ghosted condition is presented. Information regarding the phase quadrature-induced ghost component derived from the quadrature forming nature of the vestigial sideband (VSB) filter is obtained by crosscorrelating the detected video with the ghost cancel reference (GCR) signal. As a result, the minimum number of taps required to correctly remove all the ghost components is subsequently presented. The results are applied to both National Television System Committee (NTSC) and phase alternate line (PAL) television.

### I. INTRODUCTION

It is part of the nature of terrestrial television transmission that multiple paths from the transmitter to the receiver can occur due to reflections from either static objects such as mountains and buildings or moving objects such as aircraft. The reflection paths cause multiple copies of amplitude-scaled and time-displaced replicas of the transmitted signal to be received along with the direct signal. All path carriers are at the same frequency and are detected together resulting in a ghosting effect on the picture due to the nature of the television scanning circuitry. With an increasing number of people living within built up areas, deghosting is important and is receiving more commercial attention than ever before.

Deghosting the composite video signal has been a technical discussion for many years [1]. Previously, due to video sampling rates, filter lengths, and cost, real time deghosting within a commercial television has not been viable. More recently, the advent of digital signal processing (DSP) hardware running at video speeds has enabled deghosting at relatively low cost.

### II. MULTIPATH SIGNAL CHARACTERISATION

Under a no ghost condition, Bluestein [2] modeled the upper vestigial sideband (U-VSB) filter within the receiver IF chain and described an exact form for the induced phase quadrature ( $Q$ ) carrier present within the output of a VSB filter derived from the asymmetry around the carrier. The information signal upon the additive  $Q$  carrier was described by a linear transform,  $H_q(\omega)$  (a modified Hilbert

Manuscript received April 5, 1996; revised July 3, 1996. This paper was recommended by Associate Editor Y. Wang.

The author is with the Electronic Engineering Group, Department of Engineering, The University of Reading, Reading, RG6 6AY, U.K.

Publisher Item Identifier S 1051-8215(96)08063-9.

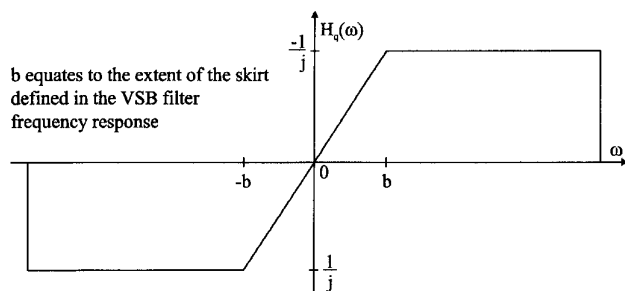

Fig. 1. Modified Hilbert transform for the U-VSB characteristic.

transform), operating upon the original inphase ( $I$ ) video signal. Giving a result whereby, over the VSB Nyquist slope, the quadrature signal is the negative differential of the original video signal. The unghosted output of the U-VSB filter was described as

$$\text{unghosted VSB output } (t) = v(t) \cdot \cos(\omega_c t) - \tilde{v}(t) \cdot \sin(\omega_c t). \quad (1)$$

It may be noted that (1) is similar to the conical single sideband (SSB) description, however,  $\tilde{v}(t)$  is the result of the original video signal  $v(t)$  convolved with the modified Hilbert transform,  $H_q(\omega)$ , as depicted in Fig. 1. Using the results from Bluestein, Sherratt and Pardoe [3] presented a mathematical analysis of the multipath signal from the transmitter to the receiver video IF (VIF) detector using a deterministic approach and an exact form for the detected video under multipath was found. The advantage of the deterministic approach was that the ghosts were treated separately rather than as a whole channel distortion, and as a result the individual ghost distortion contributions may be found. The ideal synchronously detected inphase ( $I$ ) and phase quadrature ( $Q$ ) signals were found to be

$$i(t) = v(t) + \sum_{i=1}^N \alpha_i \cos(\theta_i) v(t - t_{d_i}) - \sum_{i=1}^N \alpha_i \sin(\theta_i) \tilde{v}(t - t_{d_i}) \quad (2)$$

$$q(t) = -\tilde{v}(t) - \sum_{i=1}^N \alpha_i \sin(\theta_i) v(t - t_{d_i}) - \sum_{i=1}^N \alpha_i \cos(\theta_i) \tilde{v}(t - t_{d_i}) \quad (3)$$

where

- $v(t)$  original video (direct and delayed);
- $\tilde{v}(t)$   $Q$  component derived from the VSB filter (direct and delayed);
- $N$  number of multipaths present,
- $\alpha_i$   $i$ th ghost attenuation relative to the intended video;
- $t_{d_i}$   $i$ th ghost additive path delay extended to the time of the next sample (due the operation of a sample and hold);
- $\theta_i$   $i$ th ghost carrier phase relative to the intended video carrier.

It may be seen that the ghosting effect is linear and obeys superposition, so for simplicity, the detected signals may be considered for one ghost with the later extension of further amplitude scaled and delayed versions of  $v(t)$  and  $\tilde{v}(t)$ . Although (2) and (3) describe postghosts (arrive after the intended signal), preghosts (arrive before the intended signal) may be considered by shifting the time line within  $i(t)$  and  $q(t)$  which is permissible within a linear system. It is almost without exception that deghosting is performed on the detected composite signal where only the inphase detected signal is present.