

An Adaptive Protection Technique for Smart Distribution Network

Abdulfetah Shobole^{1,*}, Mustafa Baysal², Mohammed Wadi¹, Mehmet Rida Tur³

¹Electrical Engineering Department, Istanbul Sabahattin Zaim University,
Halkali Campus, Istanbul, Turkey

²Electrical Engineering Department, Yildiz Technical University,
Davutpasa Campus, Istanbul, Turkey

³Electrical Engineering Department, Batman University,
Batman, Turkey

abdulfetah.shobole@izu.edu.tr

Abstract—The future distribution networks (DNs), commonly known as the smart grid is expected to be reliable, efficient, and can accommodate renewable energy resources. The smart distribution network has to withstand the technical challenges related to the integration of distributed generations (DGs). Among these technical challenges, protection malfunctioning with the increased integration of DGs is one of the important issues, which requires a great concern. Thus, a protection philosophy, which can suit the future smart grid requirements with respect to increased integration of DGs, has to be devised. In this paper, an adaptive protection technique, which is based on the characteristics of fault-current and load-current variation, is proposed. In the proposed method, intelligent electronic devices (IEDs) monitor the status of circuit breakers (CBs) and DGs. If any status change occurs, the calculation and relay agents are triggered to update the IEDs. DigSILENT PowerFactory is used to verify the suggested philosophy. Especially DigSILENT Programming Language (DPL) is used to model the adaptive protection. The solar power plant in the Antalya vicinity in Turkey is used to verify the proposed method. The results of the simulation study show the correct operation and effectiveness of the proposed method.

Index Terms—Smart grids; Power system protection; Distributed power generation; Power system distribution.

I. INTRODUCTION

The integration of distributed generations (DGs) into distribution networks results in a bidirectional current flow, thus it creates a similarity between transmission networks and distribution networks [1]. Due to the integration of DGs, the distribution networks (DNs) are transformed from the radial to the multi-source system. Moreover, the magnitude, duration, and direction of the fault currents also undergo a change [1]–[6].

To verify this, consider, for example, the DigSILENT PowerFactory model of the Antalya Solar Power Plant (SPP) connected to the utility network as shown in Fig. 1. The DigSILENT PowerFactory is power system modelling, analysis and simulation tool, which is commonly used for studying the grid integration of new generation-technologies [4]. The solar power plant site under consideration is located

at 36.25 ° latitude and 29.92 ° longitude. It is one of the prominent lands for solar energy generation in Turkey.

As shown in Fig. 1, except the Finike-Substation, which belongs to the Turkish Transmission Company, the rest of the transmission network is represented by its impedance and short circuit capacity. The complete network is not radial and there is a bidirectional flow of energy. The detailed description of this power plant is available in [3].

In Fig. 1, the black boxes on each side of the bus bar indicate the position of the protection relays and their circuit breakers. In this network, faults are applied on the line at a point, which is far way 5 % the length of each cable from the place where the relays are placed. The A-group relaying points R1A, R2A, R3A, and R4A are in sequence in the direction of the red arrow (Fig. 1). Similarly, B-group relaying points R1B, R2B, R3B, and R4B are in sequence in the direction of the green arrow (Fig. 1). The fault current trend is shown in Fig. 2, and it is not the same as the fault current trend in the traditional distribution system.

This variation of the fault current trend leads to a requirement of a new protection philosophy to handle the protection challenges arising from integrating DGs into the distribution network [7]–[10]. For this kind of DN, directional relays, differential relays, distance relays, and voltage-based relays can be used as an alternative to the relatively inefficient, non-directional overcurrent relays [11], [12]. For the distance relays, the shortness of the distance and the status of the DGs can influence the correct operation of the relay [13], [14]. The voltage-based protection is independent of the direction and the magnitude of the fault current [15]. However, load switching and other transient conditions can affect the voltage [15], [16]. Besides, achieving selective operation by using this method can be difficult as distribution lines are not mostly long enough to establish reach-impedance of the relays. These limitations can be resolved by the differential protection scheme, as it is independent of DG type, location, and size. However, the differential scheme may not be an economical solution due to its communication requirement and cost. Moreover, the differential relay cannot provide backup protection, and it requires additional backup protection.

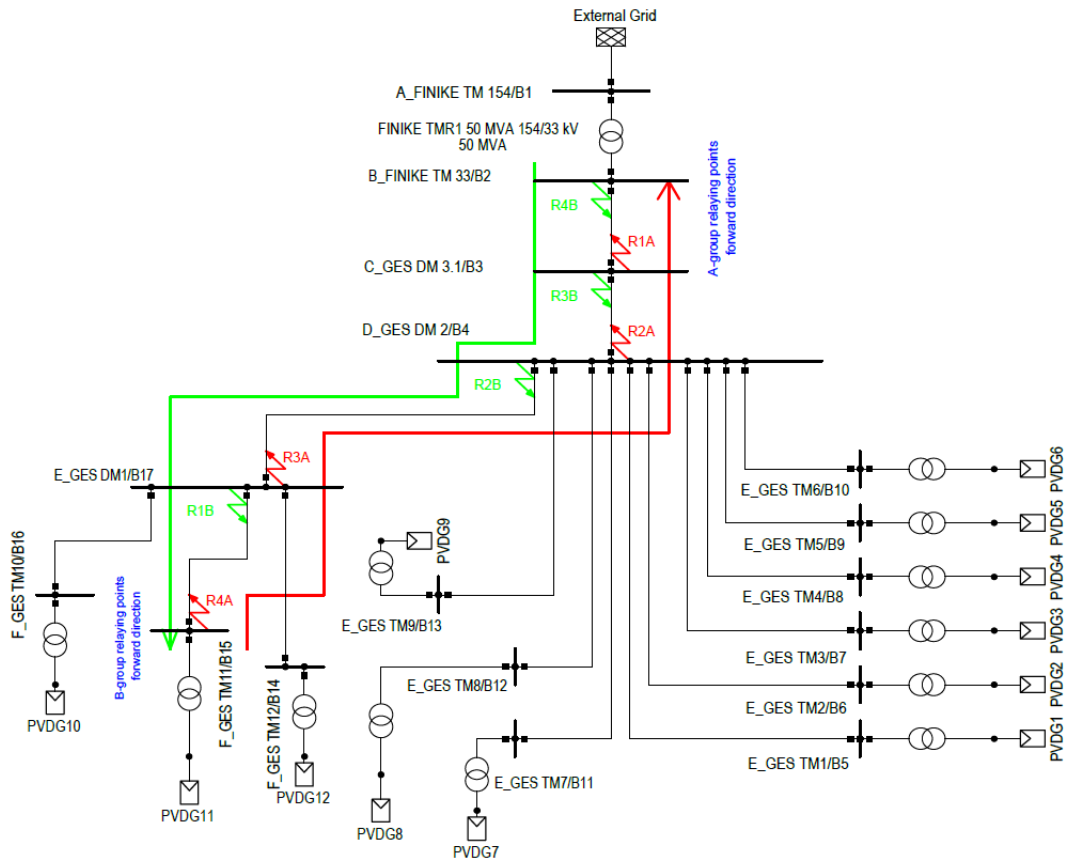

Fig. 1. Scheme of Antalya Solar Power Plant Project.

In [11], a communication-assisted overcurrent protection for radial distribution networks with DGs is discussed. It uses a directional overcurrent relay with reverse blocking and inter-tripping functions. However, this method cannot handle the protection requirements when DGs are integrated and the level of integration changes.

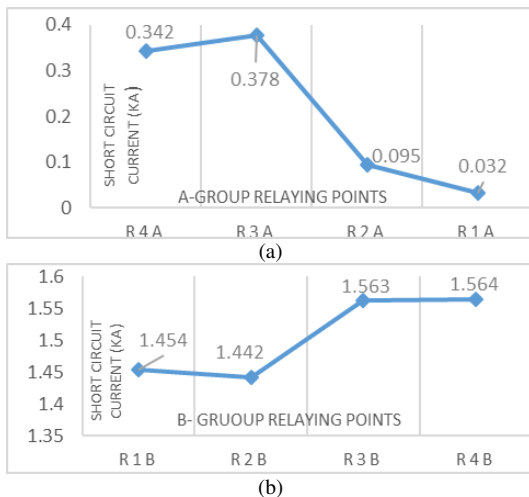

Fig. 2. The fault current variation for the Antalya solar power plant.

An alternative approach is to use an adaptive protection, which is described as the common operation of the System Integrity Protection Scheme (SIPS). The primary goal of SIPS is to improve the security and integrity of the power system or the strategic portion of the power system [17], [18]. All SIPSs consist of monitoring, detection, communication, decision-making, and execution components [19]. The adaptive protection scheme, which can adjust the

settings to the actual state of the active distribution network, can handle the protection problems with regard to DGs integration. These protection methods are proposed in [20]–[27]. Most of the proposed methods are based on using lookup tables and memory. As in [28]–[33], the general procedures followed in the adaptive protection are:

- A central or distributed unit continuously monitors the operational parameters of protected systems;
- By analysing the status of circuit breakers (CBs) and/or DGs, the structure of the networks is recognized by the algorithms in the monitoring (central or distributed) unit;
- New protection settings are calculated (online or offline) based on the system's operating conditions and the system structure;
- An efficient communication is used to exchange data and settings between control units and the protection relays.

In [30], [34], an adaptive protection method, which considers the change in the size and number of DGs, is proposed. However, these methods are based on the pre-calculated setting groups, which correspond to a limited number of network configurations. In [35], a method of matching so many network configurations to a few setting groups is proposed. Nevertheless, it is still based on using pre-calculated setting groups. According to this method, the central controller is used to identify the network configuration change. The change in the network configuration is categorized among few clusters, which are already defined. However, this may affect the accuracy of setting values as it matches to the cluster of network configuration rather than to the actual network configuration

itself. In [36]–[45], Multi-agent system (MAS) based approach for smart grid protection is proposed as an alternative solution to the drawback of the centralized adaptive protection. However, the MAS based method highly rely on the reliability of the communication network.

The novelty of the proposed method is directly matching each network configuration to the actual setting without much burden on the central controller. Besides, this method can be used with any DG type and penetration level. The settings are not based on pre-calculated setting groups. Moreover, it is not entirely reliant on communication between the central controller and the relays. Among the protection relays (intelligent electronic devices (IEDs)), a particular IED can be assigned as the monitoring agent. The coordinator IED is only responsible to initiate the setting calculations of the peripheral IEDs and monitor network configuration. All the IEDs are capable of handling protection setting calculations by themselves. The controller IED communicates only with peripheral relays and circuit breakers (CBs). This greatly reducing the communication burden in contrast to the MAS based methods reported in [36]–[45]. The setting values are exchanged between the IEDs, which are coordinated together. This reduces the criticality of a central controller and increases the protection system reliability. In the proposed method, the central controller is only used for detecting any changes in the network configuration and informs end relays to start the adaptive protection. As a significant advantage, the proposed protection philosophy can be used with the currently used intelligent electronic devices (IEDs). In the power system industry, the use of Ethernet-based, fiber optics, and large bandwidth communication systems are becoming prevalent. The interoperability protocols like IEC 61850 can be used to implement the required communication between IEDs [46]–[54]. The discussion of the technical details of communication is not the scope of this paper.

In the following part, Section II discusses the proposed protection philosophy, Section III suggests the practical implementation techniques of the proposed method, Section IV discusses the verification of the proposed method by using DigSILENT PowerFactory, and in Section V conclusions are given.

II. THE PROPOSED PROTECTION PHILOSOPHY

In order to overcome the protection coordination issues related to DGs integration into the DNs, an adaptive based protection approach is developed. The proposed protection philosophy is shown in the flowchart in Fig. 3. According to this method, directional overcurrent relay has to be used on the two sides of each branch (Fig. 4) in the DNs. In the DNs, there is a time constraint with respect to overcurrent protection due to a limitation of fault clearing time designated by transmission line operators (which is considered as critical points later on in this paper). Thus, the time assignment and the time multiplier setting (TMS) has to be used effectively.

In this method, the network is initially considered as a

radial from the connection point to the end feeders. The end feeder can be a DG, a load or a connection point to the utility network. The allowable minimum time and time multiplier setting are assigned to the initial relays (e.g., relay R1A in Fig. 1). Then, the time and the time multiplier setting of the other backup relay (R2A) will be determined based on the short circuit current between its own relaying point and the next relaying points on the same path. In a similar way, the DGs terminal is used as the initial point for assigning the minimum time and TMS values. If we take the network shown in Fig. 1 as an example, R1B will be assigned to the initial time and TMS values. The next backup relay R2B will be assigned to the time and the TMS values with respect to short circuit current between itself and the other relaying points in the same direction. This process will continue for all relays on the same path of protection coordination.

It should be noticed, that during the coordination process at the place combining feeders (from many feeders to one feeder), the incoming relays might have different time and time multiplier setting. In this case, the maximum of these setting values has to be selected and sent to the upstream relay. For the splitting feeders (from one feeder to many feeders), the downstream relay can send its settings to the upstream relays and each of them assigns different time and TMS values as each of the settings follow a different path.

The advantage of this algorithm is its simplicity and that it can be implemented in the currently used IEDs. It is also adaptable, and the coordination can change with respect to changes in the DGs level or the network configuration. In this method, the first relays will be initialized for each path when any change in the network occurs. In this case, each relay is assumed to have a capability of processing simple mathematical operations, adjusts its own setting, and then sends the setting values to the upstream relays. Once the coordination is completed, the relays can work in a coordinated manner without further requirement of the communication.

As an additional future, for the faults occurring on the cable or the transmission line interconnecting the substations, the fault clearance can be speeded up. This is because the coordination process is done on a line or cable at two endings. Since the time setting is increased from two sides in the opposite direction by default, time settings of one of the two relays will be smaller. For example, consider the fault on the branch shown in the Fig. 4, the two relays will see the fault in their forward direction. The relay with smaller time and TMS settings will pick-up first and send follow me signal to the corresponding relay on the opposite side. Consequently, the corresponding relay will operate in a shorter time than its actual time and TMS settings. The logic to speed up this protection is demonstrated in Fig. 4. In Fig. 4, the designations CiA and CiB mean the circuit breakers on the side of relays RiA and RiB, respectively. The lines designated by RA and RB as shown in Fig. 5 indicate the time setting in the opposite directions. While the red line indicates the speeded up operation of the fault clearing when the communication is available (Fig. 5).

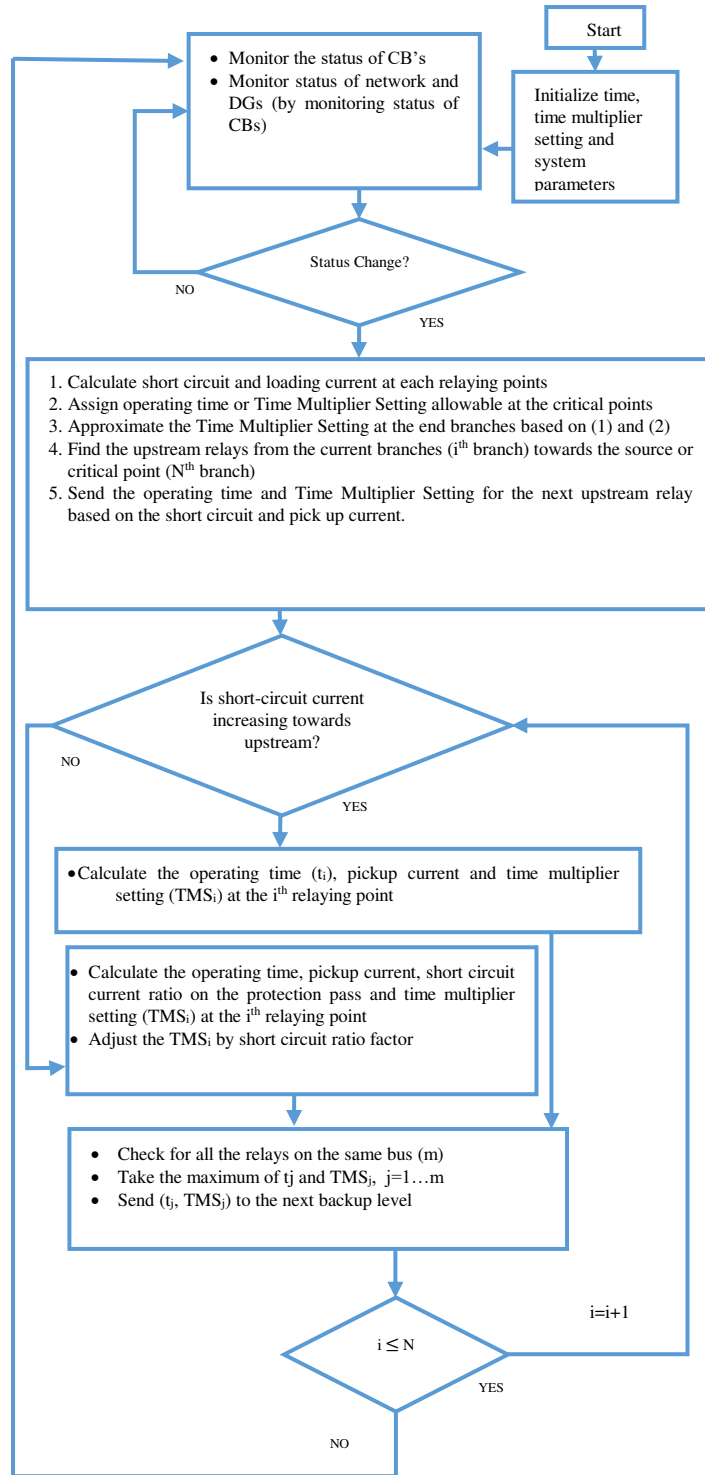

Fig. 3. An adaptive Protection Setting Method for DNs with DGs.

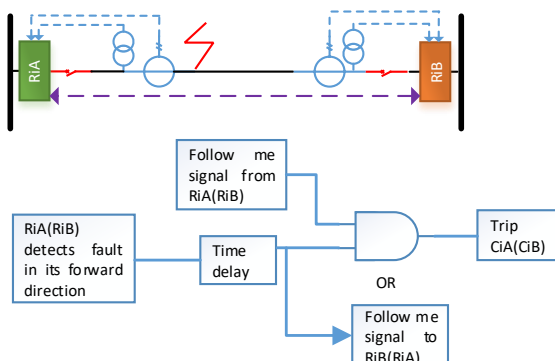

Fig. 4. The logic to be implemented in the relay.

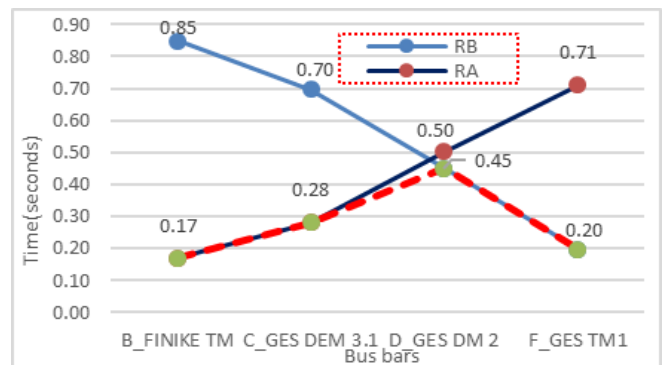

Fig. 5. Speeding up the relay operation.

III. IMPLEMENTATION SUGGESTIONS

To implement the proposed method, adaptable directional IEDs can be used. A reliable and fast communication infrastructure is one of the main characteristics of the smart distribution network. The IEDs can communicate with each other, as well as with the controller, by using standard communication protocols like IEC 61850. The signals route is shown in Fig. 6 for a particular example of DN with DGs integration.

The controller can be an independent IED and can contain monitoring and calculation agents. It can be central (single IED) or distributed (more than one IED with one coordinator) depending on the requirement for the reliability. The monitoring agent (IED) detects the configuration change in the network by monitoring the status of the CBs in real time. For example, Table I shows the status of circuit breakers (CBs) as 0 when CB is open and as 1 when CB is closed. For this particular case, in Table I, four circuit breakers (CB1, CB2, CB3, and CB4) are considered. In actual situation, the number of CBs can be greater and they can be placed anywhere in the power system network. From Table I, there is no change in the status of CBs between times $(t - 2)^{\text{th}}$ and $(t - 1)^{\text{th}}$, therefore the monitoring agent will not trigger the calculation agent. However, at the t^{th} time, CB2's status is changed from an open position to a closed position. This condition can be easily understood from the "xor" logic, which gives an output high or one for two different inputs and gives an output low or zero for the

same inputs.

The calculation agent contains a program for load flow and short circuit calculation. The real world implementation suggestion for these calculations can be by including online load flow and short circuit calculation functions inside the Distribution Management Systems (DMS), which can communicate with a controller agent. The network structure in the program will be updated in parallel with CB's status change. Thus, the results of load flow and short circuit calculations are updated for every change in the network. The relay agent is assumed to have extra features like calculating the pickup time and current at each relaying point by using the fault current and loading currents. For example, for an inverse time overcurrent coordination, the relay at upstream position (assume $(n + 1)^{\text{th}}$ position if n^{th} position is taken as a reference), can determine its time multiplier setting (TMS_{n+1}) as in (1)

$$TMS_{n+1} = \frac{t_n + CTI}{0.14 \left(\frac{I_n}{I_{p_{n+1}}} \right)^{0.02} - 1}, \quad (1)$$

where I_n is the fault current through downstream relay and $I_{p_{n+1}}$ is the pickup current of the upstream relay. The loading and fault current at each relaying point can be received from the controller IEDs' calculation agent.

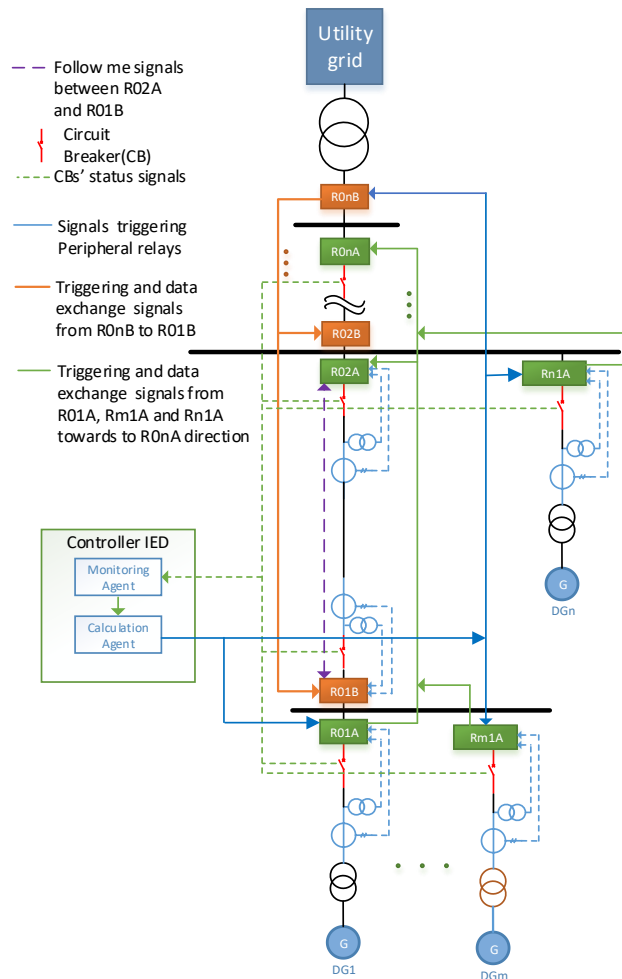

Fig. 6. Signal paths for the proposed communication method.

TABLE I. THE STATUS OF CBS TO DETECT NETWORK CONFIGURATION.

Designation	Time	CB1	CB2	CB3	CB4
A	$(t - 2)^{\text{th}}$	1	0	1	0
B	$(t - 1)^{\text{th}}$	1	0	1	0
C	t^{th}	1	1	1	0
A xor B	$(t - 1)^{\text{th}}$	0	0	0	0
B xor C	t^{th}	0	1	0	0

IV. VERIFICATION AND ANALYSIS

As discussed previously, the proposed method automatically detects any change in the network and initiates the adaptive protection. The adaptive protection uses load flow and short circuit calculation to determine the new setting. The rate of change of the fault currents strongly depends on the ability of the DG to contribute to the fault current. Solar PV based DGs do not provide a sustainable fault current during a grid disturbance since they are connected through an inverter. This creates more challenge in selective coordination of current based protection relays

as there is no sufficient fault current difference between the relaying points. In contrast, wind power plants can contribute more current during disturbance and the selective coordination is easier than PV based DGs since the fault current vary greatly among the relaying points.

To verify the protection philosophy, part of the SPP in Antalya region of Turkey, which is shown Fig. 7, is modelled inside DigSILENT PowerFactory. The SPP is connected to a DN in the Antalya region known as "AKEDAS". The "AKEDAS" is connected to transmission network of Turkey known as "TEİAŞ" network. The motive for selection of this network is that it represents the actual DNs with DGs integrated. In addition, the authors were involved in the design of this SPP and there is a full data of the network. Moreover, in Turkey, the integration of SPP to DNs has increased in the last few years and there is a great challenge for the protection of SPPs and DNs. Consequently, the results from this work are planned to be used in upcoming pilot projects.

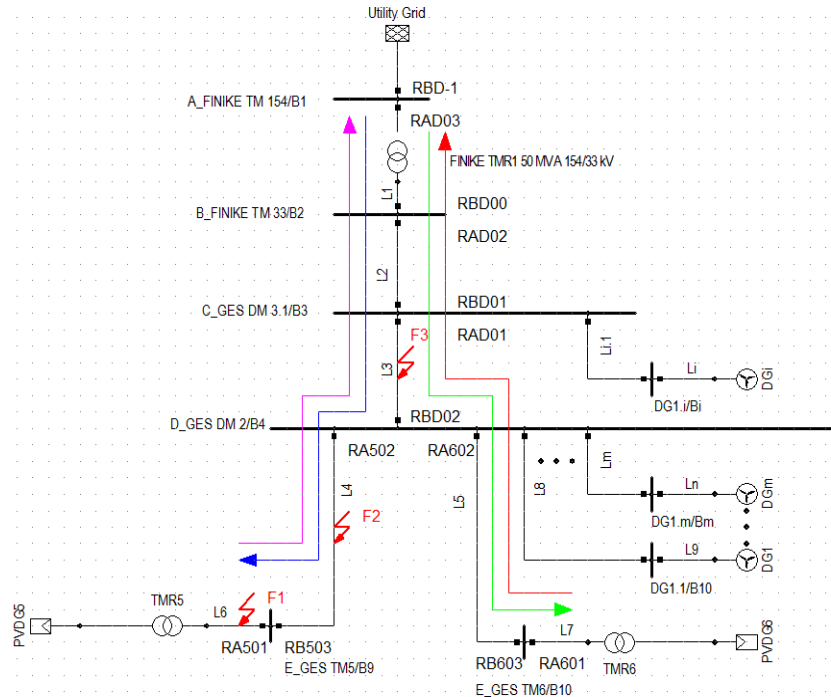

Fig. 7. The Protection coordination paths for simulation analysis.

The DPL (DigSILENT Programming Language) is used to model the adaptive protection philosophy. As discussed in the previous section, the monitoring agent program checks for the status of the CBs in real time. If any change occurred, it triggers the calculation agents. After that, it initializes the peripheral relay agents (branch and source relays).

Inside the simulation network, initially all the circuit breakers connecting the DGs to the DNs were in open position, and then closed one by one automatically by using test code. For each change of the CB's status, the adaptive protection philosophy starts to adjust the settings of all the relays.

Although the method is applicable to other protection functions like a short circuit and earth fault protection, for simulation purpose, directional overcurrent function is used and its forward direction set towards the cable (transmission line). The characteristic curve, which is used for each relay,

is IEC 255-3 normal inverse as in (2)

$$T = TMS * \frac{0.14}{\left(\frac{I}{I_p}\right)^{0.02} - 1}, \quad (2)$$

where T, I, I_p , and TMS are pickup time, fault current, pickup current, and time multiplier setting of the relay, respectively.

For this simulation study, the case where the DGs integration is varied from 4 MW to 15 MW is considered. The relays at the periphery are assigned with TMS of 0.1. The suitable value of TMS can be selected based on the other relay's TMS and the network condition.

As shown in Fig. 8 and Fig. 9, the TMS and the time are changing with the level of DGs integration. These results show how the setting of the relays is changing with DGs

deployment. If the adaptive coordination philosophy is not used, the coordination could have been lost for each path. If Fig. 8(a) is considered, the TMS is increasing from relay RA601 to RA602, but it is decreasing from relay RA602 to RAD01. From the network's structure used for simulation (Fig. 7), there is 1 MW DG on the path of protection relays RA601 and RA602. The load flow current for this path is not changing since it depends only on this DG even if the DG's integration is increased (e.g., from DG1 to DG_m as shown in Fig. 7). In addition, the fault current is increasing since it comes from other nearby feeders. In contrast, for the relay RAD01, the pickup current increases with increasing of integration. Whereas, there is no much change in the fault current since it comes only from the grid side (when a fault is applied, e.g., at F3).

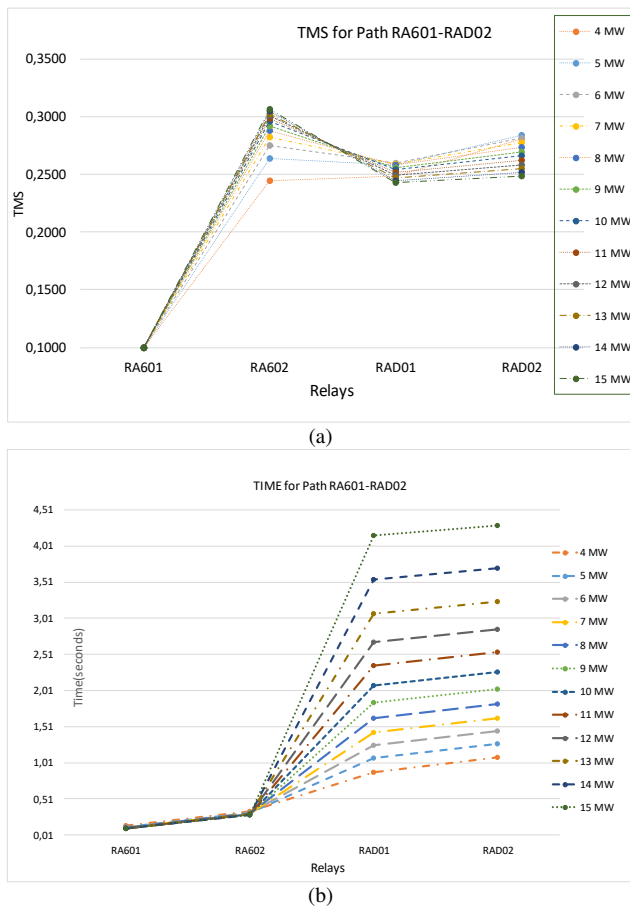

Fig. 8. (a) TMS and (b) operating time at the maximum fault currents for the Path RA601 –RAD02.

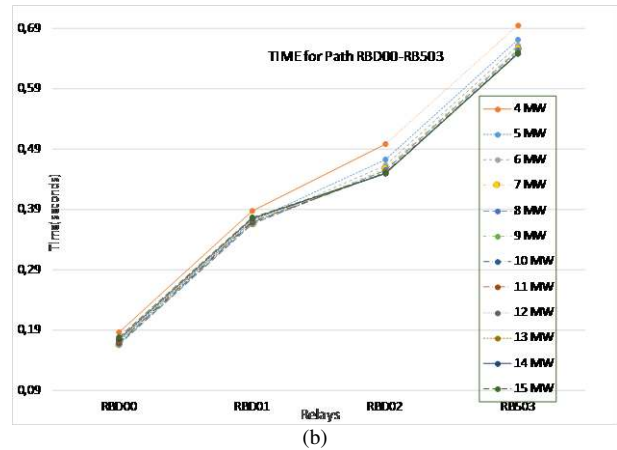
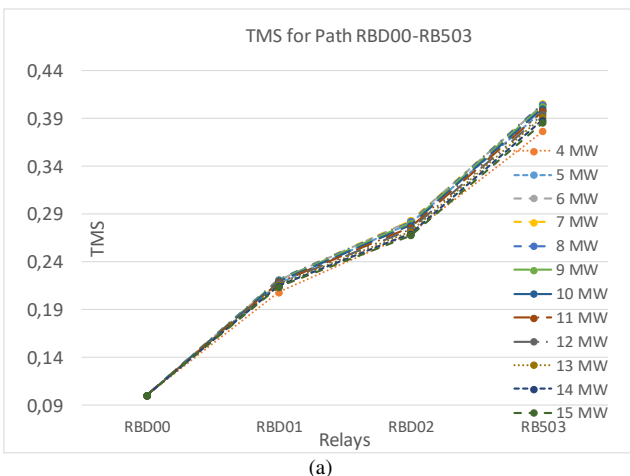

Fig. 9. (a) TMS and (b) operating time at the maximum fault currents for the Path RBD00-RB503.

Consequently, the decrease in TMS from RA602 to RAD01 created no problem on the coordination as shown in Fig. 10. Additionally, the TMS is increasing from RAD01 to RAD02 as shown in Fig. 8(a). Furthermore, Fig. 8(b) shows the operating time for a fault near to the relaying points. The pattern shows relays RA601 and RA602 operate very fast as the fault current coming from the nearby is high. However, relays RAD01 and RAD02 are operating slowly relatively as the fault in the relays direction is not as high as fault current of relays RA601 and RA602. Similar trends are shown in Fig. 9 for relays RBD00-RB503, and in this case, the TMS is observed increasing.

After the settings are automatically calculated, faults are applied at F1, F2, and F3, which are the midpoints of lines L6, L4, and L3, respectively, as shown in Fig. 7. When the MW integration is increased from 4 MW to 15 MW, the pickup current and TMS are automatically adjusted as shown in Table II and III.

In Table II and Table III, the advantage of the proposed adaptive protection is clearly visible. If, e.g., setting no. -1 ($I_p = 62.6$ A and $TMS = 0.25$) is used for all conditions of DGs' integration, the relay RAD01 operates wrongly when the integrated DGs are above 4 MW and above. In a similar way, if setting no. -5 is used ($I_p = 146.03$ A and $TMS = 0.26$), the relay RAD01 operates wrongly under normal condition for integration of above 9 MW. In Table III, the shaded region with the designation "NO" indicates the region where the relays are not operating wrongly. Settings 10, 11, and 12 seems to work in all cases, but if these settings are used, the relay may not detect low current fault conditions. In addition, they are not working for higher integration of DGs (for example 100 MW) in a similar way to the other settings. In the proposed method, e.g., if 6 MW DG is integrated, the setting will be automatically changed to setting no. 6 ($I_p = 187.53$ A and 0.42) for the relay RAD02 as shown in Table III. Thus, using the proposed adaptive method avoids the wrong operation. It does not also depend on the limited setting groups. In Fig. 10, the time inverse characteristics for the relays RA601, RA602, RAD01, and RAD02 at a particular instant are shown, which indicate their proper coordination. In a similar way, in Fig. 11, the inverse time characteristics for relays RBD00, RBD01, RBD02, and RB503 are shown at a particular instant.

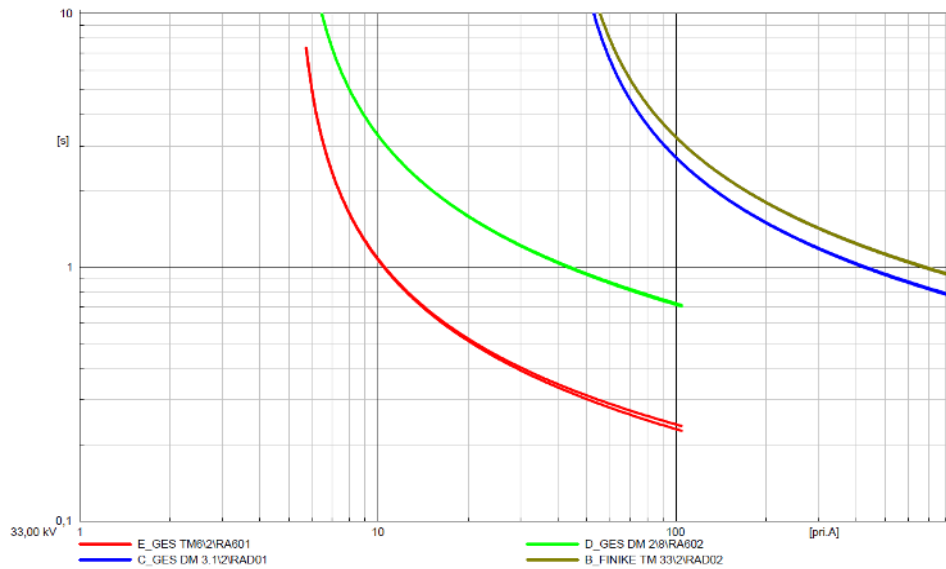

Fig. 10. Time inverse characteristics for relays RA601, RA602, RAD01, and RAD02.

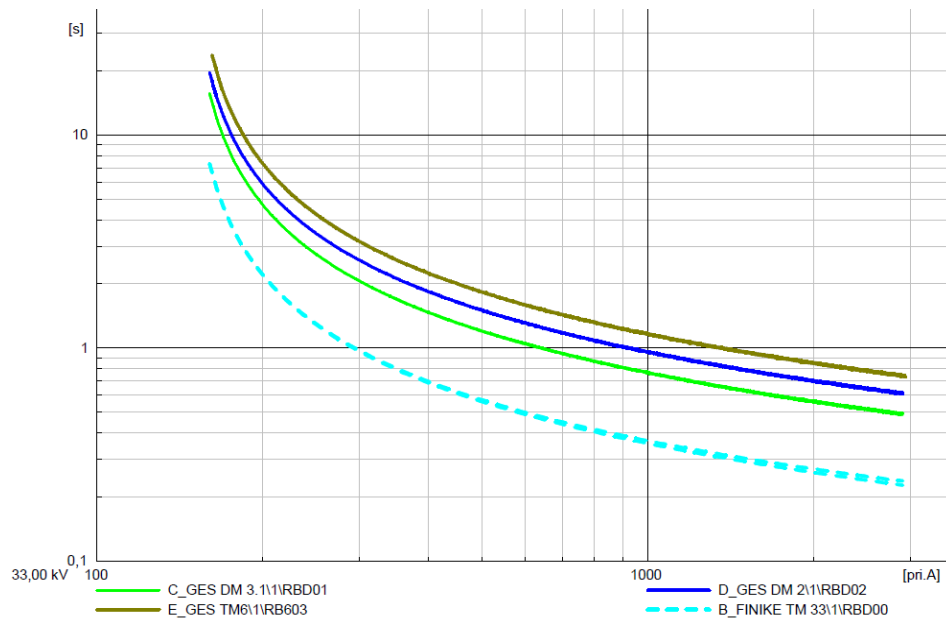

Fig. 11. Time inverse characteristics for relays RBD00, RBD01, RBD02, and RB503.

TABLE II. THE WRONG OPERATIONS RESULTED FROM DGS INTEGRATION AND ADAPTIVE SETTING'S ADVANTAGE AT RELAY RAD01.

Settings			Operating time of RAD01 for loading variations from 4 MW (I_{L4}) to 15 MW (I_{L14})											
			$I_{L4} = 52.17$	$I_{L5} = 69.58$	$I_{L6} = 86.98$	$I_{L7} = 104.34$	$I_{L8} = 121.69$	$I_{L9} = 139.01$	$I_{L10} = 156.31$	$I_{L11} = 173.58$	$I_{L12} = 190.83$	$I_{L13} = 208.06$	$I_{L14} = 225.27$	$I_{L15} = 242.46$
No.	$I_p(A)$	TMS												
1	62.60	0.25	NO*	16.45	5.28	3.39	2.60	2.17	1.89	1.69	1.54	1.43	1.34	1.27
2	83.50	0.26	NO	NO	44.25	8.08	4.77	3.52	2.86	2.45	2.17	1.96	1.80	1.68
3	104.37	0.26	NO	NO	NO	NO	11.82	6.33	4.48	3.56	2.99	2.62	2.34	2.14
4	125.21	0.26	NO	NO	NO	NO	NO	17.34	8.16	5.54	4.29	3.56	3.07	2.73
5	146.03	0.26	NO	NO	NO	NO	NO	NO	26.51	10.42	6.73	5.08	4.14	3.54
6	166.81	0.26	NO	NO	NO	NO	NO	NO	NO	45.01	13.30	8.09	5.94	4.77
7	187.57	0.25	NO	NO	NO	NO	NO	NO	NO	NO	102.94	17.11	9.68	6.90
8	208.30	0.25	NO	NO	NO	NO	NO	NO	NO	NO	NO	NO	22.46	11.58
9	229.00	0.25	NO	NO	NO	NO	NO	NO	NO	NO	NO	NO	NO	30.54
10	249.67	0.25	NO	NO	NO	NO	NO	NO	NO	NO	NO	NO	NO	NO
11	270.32	0.24	NO	NO	NO	NO	NO	NO	NO	NO	NO	NO	NO	NO
12	290.95	0.24	NO	NO	NO	NO	NO	NO	NO	NO	NO	NO	NO	NO

Note: *NO means the relay will not pick up and there is no wrong operation.

TABLE III. THE WRONG OPERATIONS RESULTED FROM DGS INTEGRATION AND ADAPTIVE SETTING'S ADVANTAGE AT RELAY RAD02.

Settings			Operating time of RAD02 for loading variations from 4 MW (I_{L3}) to 15 MW(I_{L14})											
			$I_{L4} = 69.51$	$I_{L5} = 86.91$	$I_{L6} = 104.28$	$I_{L7} = 121.64$	$I_{L8} = 138.97$	$I_{L9} = 156.27$	$I_{L10} = 173.56$	$I_{L11} = 190.82$	$I_{L12} = 208.06$	$I_{L13} = 225.28$	$I_{L14} = 242.48$	$I_{L15} = 259.65$
No.	$I_p(A)$	TMS												
1	83.41	0.45	NO	77.20	14.16	8.37	6.18	5.02	4.29	3.80	3.44	3.16	2.94	2.76
2	104.29	0.44	NO	NO	NO	20.13	10.77	7.64	6.06	5.10	4.46	4.00	3.65	3.37
3	125.14	0.44	NO	NO	NO	NO	29.12	13.72	9.31	7.21	5.98	5.17	4.59	4.16
4	145.96	0.43	NO	NO	NO	NO	NO	44.14	17.38	11.22	8.48	6.92	5.91	5.20
5	166.76	0.43	NO	NO	NO	NO	NO	NO	74.47	22.06	13.42	9.87	7.92	6.69
6	187.53	0.42	NO	NO	NO	NO	NO	NO	NO	168.96	28.27	16.00	11.41	9.01
7	208.27	0.42	NO	NO	NO	NO	NO	NO	NO	NO	NO	36.99	19.08	13.15
8	228.98	0.41	NO	NO	NO	NO	NO	NO	NO	NO	NO	NO	50.14	22.82
9	249.67	0.41	NO	NO	NO	NO	NO	NO	NO	NO	NO	NO	NO	72.41
10	270.33	0.40	NO	NO	NO	NO	NO	NO	NO	NO	NO	NO	NO	NO
11	290.97	0.40	NO	NO	NO	NO	NO	NO	NO	NO	NO	NO	NO	NO
12	311.58	0.39	NO	NO	NO	NO	NO	NO	NO	NO	NO	NO	NO	NO

V. CONCLUSIONS

False tripping can occur when PV based DGs are integrated into ϵ -DNs. The trend of the fault current is not only increasing or decreasing in one direction only when the DGs are integrated. Due to this fact, the traditional overcurrent needs modification to be used for the protection of the existence of DGs. The protection method based on the adaptive philosophy can handle these problems. In the proposed method, the status of CBs, which indicates the connection statuses of DGs, are monitored continuously in real time, and if any change happens, the calculation and setting agents are triggered to initialize the calculation of relays setting automatically. The proposed method can vary with each MW variation of DGs. Even though it is adaptive, it is based on the currently used protection functions and IEDs. The follow me signals is used to speed up the operation of the relay when the faults happen to the cables or lines between the buses. After the setting is loaded to the relay, the protection is not fully dependent on the communication, but the availability of communication can be used as an advantage. By using DPL, the protection philosophy is proven to work properly. The relays successfully adapted their setting for any change in the DGs integration. The coordination between the relays is also verified for different DG integration levels.

CONFLICTS OF INTEREST

The authors declare that they have no conflicts of interest.

REFERENCES

- [1] N. Hadjsaid, J.-F. Canard, and F. Dumas "Dispersed generation impact on distribution networks", *IEEE Comput. Appl. Power*, vol. 12, no. 2, pp. 22–28, 1999. DOI: 10.1109/67.755642.
- [2] E. Ragaini and A. Oudalov "Microgrids: Building blocks of the smart grid adaptive protection schemes for microgrids", 2012 3rd IEEE PES ISGT Europe, Berlin, Germany, October 14–17, 2012.
- [3] A. Shobole, M. Baysal, M. Wadi, and M. R. Tur, "Effects of distributed generations' integration to the distribution networks case study of solar power plant", *Int. J. Renew. Energy Res.*, vol. 7, no. 2, pp. 954–964, 2017.
- [4] C. Profile, "Power System Engineering and Software DigSilent " Network. [Online]. Available: https://www-lamp.digsilent.de/bottoms/DemoVersion/PowerFactory_A4_Low_Res.pdf
- [5] H. Jiadong, Zh. Zeyun, and D. Xiaobo, "The influence of the distributed generation to the distribution network line protection and countermeasures", *Phys. Procedia*, vol. 24, Part A, pp. 205–210, 2012. DOI: 10.1016/j.phpro.2012.02.031.
- [6] Y. Firouz, S. Farhadkhani, J. Lobry, F. Vallée, A. Khakpour, and O. Durieux, "Numerical comparison of the effects of different types of distributed generation units on overcurrent protection systems in MV distribution grids", *Renew. Energy*, vol. 69, pp. 271–283, 2014. DOI: 10.1016/j.renene.2014.03.035.
- [7] S. A. Hosseini, H. A. Abyaneh, S. H. H. Sadeghi, F. Razavi, and A. Nasiri, "An overview of microgrid protection methods and the factors involved", *Renew. Sustain. Energy Rev.*, vol. 64, pp. 174–186, 2016. DOI: 10.1016/j.rser.2016.05.089.
- [8] T. S. S. Senarathna and K. T. M. Udayanga Hemapala, "Review of adaptive protection methods for microgrids", *AIMS Energy*, vol. 7, no. 5, pp. 557–578, 2019. DOI: 10.3934/energy.2019.5.557.
- [9] M. G. Kanabar, I. Voloh, and D. McGinn, "A review of smart grid standards for protection, control, and monitoring applications", in *Proc. of 2012 65th Annu. Conf. Prot. Relay Eng.*, 2012, pp. 281–289. DOI: 10.1109/CPRE.2012.6201239.
- [10] J. Kennedy, P. Ciufu, and A. Agalgaonkar, "A review of protection systems for distribution networks embedded with renewable generation", *Renew. Sustain. Energy Rev.*, vol. 58, pp. 1308–1317, 2016. DOI: 10.1016/j.rser.2015.12.258.
- [11] V. C. Nikolaidis, E. Papanikolaou, and A. S. Safigianni, "A communication-assisted overcurrent protection scheme for radial distribution systems with distributed generation", *IEEE Trans. Smart Grid*, vol. 7, no. 1, pp. 114–123, 2016. DOI: 10.1109/TSG.2015.2411216.
- [12] M. Monadi, M. A. Zamani, J. I. Candela, A. Luna, and P. Rodriguez, "Protection of AC and DC distribution systems embedding distributed energy resources: A comparative review and analysis", *Renew. Sustain. Energy Rev.*, vol. 51, pp. 1578–1593, 2015. DOI: 10.1016/j.rser.2015.07.013.
- [13] S. Mirsaedi, D. M. Said, M. W. Mustafa, M. H. Habibuddin, and K. Ghaffari, "Fault location and isolation in micro-grids using a digital central protection unit", *Renew. Sustain. Energy Rev.*, vol. 56, pp. 1–17, 2016. DOI: 10.1016/j.rser.2015.10.162.
- [14] S. Mirsaedi, D. M. Said, M. W. Mustafa, M. H. Habibuddin, and K. Ghaffari, "Design and testing of a centralized protection scheme for micro-grids", *J. Cent. South Univ.*, vol. 22, no. 10, pp. 3876–3887, 2015. DOI: 10.1007/s11771-015-2932-9.
- [15] P. T. Manditereza and R. C. Bansal, "Protection of microgrids using

- voltage-based power differential and sensitivity analysis”, *Int. J. Electr. Power Energy Syst.*, vol. 118, p. 105756, 2020. DOI: 10.1016/j.ijepes.2019.105756.
- [16] H. Al-Nasser, M. A. Redfern, and F. Li, “A voltage based protection for micro-grids containing power electronic converters”, in *Proc. of 2006 IEEE Power Eng. Soc. Gen. Meet. PES*, 2006, pp. 1–7. DOI: 10.1109/pes.2006.1709423.
- [17] E. Hillberg *et al.*, “System integrity protection schemes - Increasing operational security and system capacity”, in *Proc. of 44th Int. Conf. Large High Volt. Electr. Syst.*, 2012.
- [18] S. Skok and I. Ivankovic, “System integrity protection schemes for future power transmission system using synchrophasors”, in *Proc. of 2019 International Conference on Smart Grid Synchronized Measurements and Analytics (SGSMA)*, 2019, pp. 1–7. DOI: 10.1109/SGSMA.2019.8784463.
- [19] J. Sykes *et al.*, “IEEE/PES PSRC report on design and testing of selected system integrity protection schemes”, in *Proc. of 2014 67th Annu. Conf. Prot. Relay Eng. (CPRE)*, 2014, pp. 738–742. DOI: 10.1109/CPRE.2014.6799039.
- [20] S. AsghariGovar, S. Heidari, H. Seyedi, S. Ghasemzadeh, and P. Pourghasem, “Adaptive CWT-based overcurrent protection for smart distribution grids considering CT saturation and high-impedance fault”, *IET Gener. Transm. Distrib.*, vol. 12, no. 6, pp. 1366–1373, 2018. DOI: 10.1049/iet-gtd.2017.0887.
- [21] F. C. Souza, H. S. Sanca, F. B. Costa, and B. A. Souza, “Adaptive instantaneous overcurrent protection by frequency estimation: A case study using a real Brazilian system”, in *Proc. of IEEE Power Eng. Soc. Transm. Distrib. Conf.*, vol. 2016-July, 2016, pp. 1–5. DOI: 10.1109/TDC.2016.7520033.
- [22] A. Tjahjono *et al.*, “Adaptive modified firefly algorithm for optimal coordination of overcurrent relays”, *IET Gener. Transm. Distrib.*, vol. 11, no. 10, pp. 2575–2585, 2017. DOI: 10.1049/iet-gtd.2016.1563.
- [23] N. Tummasit, S. Premrudeepreechacharn, and N. Tantichayakorn, “Adaptive overcurrent protection considering critical clearing time for a microgrid system”, in *Proc. of 2015 IEEE Innov. Smart Grid Technol. - Asia (ISGT ASIA)*, 2016, pp. 1–6. DOI: 10.1109/ISGT-Asia.2015.7387061.
- [24] V. A. S. Rones and K. P. Vittal, “Adaptive protection schemes for feeders with the penetration of SEIG based wind farm”, in *Proc. of 2013 IEEE Innov. Smart Grid Technol. - Asia (ISGT Asia)*, 2013, pp. 1–6. DOI: 10.1109/ISGT-Asia.2013.6698725.
- [25] P. Gupta, R. S. Bhatia, and D. K. Jain, “Adaptive protection schemes for the microgrid in a smart grid scenario: Technical challenges”, in *Proc. of 2013 IEEE Innov. Smart Grid Technol. - Asia (ISGT Asia)*, 2013, pp. 1–5. DOI: 10.1109/ISGT-Asia.2013.6698729.
- [26] L. A. Montoya, D. Montenegro, and G. Ramos, “Adaptive protection based using real time and hardware-in-the-loop simulation”, in *Proc. of 2013 IEEE Grenoble Conf.*, 2013, pp. 1–4. DOI: 10.1109/PTC.2013.6652149.
- [27] Z. Zbunjak and I. Kuzle, “Advanced control and system integrity protection schemes of croatian power transmission network with integrated renewable energy sources”, in *Proc. of Eurocon 2013*, 2013, pp. 706–711. DOI: 10.1109/EUROCON.2013.6625060.
- [28] Z. Kailun, D. S. Kumar, D. Srinivasan, and A. Sharma, “An adaptive overcurrent protection scheme for microgrids based on real time digital simulation”, in *Proc. of 2017 IEEE Innov. Smart Grid Technol. - Asia (ISGT-Asia)*, 2018, pp. 1–6. DOI: 10.1109/ISGT-Asia.2017.8378368.
- [29] H. F. Habib, M. M. Esfahani, and O. Mohammed, “Development of protection scheme for active distribution systems with penetration of distributed generation”, in *Proc. of SoutheastCon 2018*, vol. 2018-April, no. 1, 2018, pp. 56–63. DOI: 10.1109/SECON.2018.8479115.
- [30] H. Muda and P. Jena, “Sequence currents based adaptive protection approach for DNs with distributed energy resources”, *IET Gener. Transm. Distrib.*, vol. 11, no. 1, pp. 154–165, 2017. DOI: 10.1049/iet-gtd.2016.0727.
- [31] Sh. Shen *et al.*, “An adaptive protection scheme for distribution systems with DGs based on optimized Thevenin equivalent parameters estimation”, *IEEE Trans. Power Deliv.*, vol. 32, no. 1, pp. 411–419, 2017. DOI: 10.1109/TPWRD.2015.2506155.
- [32] N. A. Bari and S. D. Jawale, “Smart and adaptive protection scheme for distribution network with distributed generation: A scoping review”, in *Proc. of 2016 Int. Conf. Energy Effic. Technol. Sustain. (ICEETS)*, 2016, pp. 569–572. DOI: 10.1109/ICEETS.2016.7583818.
- [33] J. P. Nascimento, N. S. D. Brito, and B. A. de Souza, “An adaptive protection algorithm for distribution systems with distributed generation”, in *Proc. of 2015 IEEE PES Innov. Smart Grid Technol. Lat. Am. (ISGT LATAM)*, 2016, pp. 165–170. DOI: 10.1109/ISGT-LA.2015.7381147.
- [34] C. I. Ciontea, C. L. Bak, F. Blaabjerg, K. K. Madsen, and C. H. Sterregaard, “Decentralized adaptive overcurrent protection for medium voltage maritime power systems”, in *Proc. of 2016 IEEE PES Asia-Pacific Power Energy Eng. Conf. (APPEEC)*, vol. 2016-Dec., 2016, pp. 2569–2573. DOI: 10.1109/APPEEC.2016.7779952.
- [35] M. Ojaghi and V. Mohammadi, “Use of clustering to reduce the number of different setting groups for adaptive coordination of overcurrent relays”, *IEEE Trans. Power Deliv.*, vol. 33, no. 3, pp. 1204–1212, 2018. DOI: 10.1109/TPWRD.2017.2749321.
- [36] T. Kato, H. Kanamori, Y. Suzaoki, and T. Funabashi, “Multi-agent based control and protection of power distribution system - Protection scheme with simplified information utilization”, in *Proc. of 13th Int. Conf. Intell. Syst. Appl. to Power Syst.*, vol. 2005, 2005, pp. 49–54. DOI: 10.1109/ISAP.2005.1599240.
- [37] E. Abbaspour, B. Fani, and E. Heydarian-Forushani, “A bi-level multi agent based protection scheme for distribution networks with distributed generation”, *Int. J. Electr. Power Energy Syst.*, vol. 112, pp. 209–220, 2019. DOI: 10.1016/j.ijepes.2019.05.001.
- [38] B. Fani, E. Abbaspour, and A. Karami-Horestani, “A fault-clearing algorithm supporting the MAS-based protection schemes”, *Int. J. Electr. Power Energy Syst.*, vol. 103, pp. 257–266, 2018. DOI: 10.1016/j.ijepes.2018.06.001.
- [39] M. S. Rahman, N. Isherwood, and A. M. T. Oo, “Multi-agent based coordinated protection systems for distribution feeder fault diagnosis and reconfiguration”, *Int. J. Electr. Power Energy Syst.*, vol. 97, pp. 106–119, 2018. DOI: 10.1016/j.ijepes.2017.10.031.
- [40] Y. Zhu, S. Song, and D. Wang, “Multiagents-based wide area protection with best-effort adaptive strategy”, *Int. J. Electr. Power Energy Syst.*, vol. 31, no. 2–3, pp. 94–99, 2009. DOI: 10.1016/j.ijepes.2008.10.008.
- [41] A. Hussain, M. Aslam, and S. M. Arif, “N-version programming-based protection scheme for microgrids: A multi-agent system based approach”, *Sustain. Energy, Grids Networks*, vol. 6, pp. 35–45, 2016. DOI: 10.1016/j.segan.2016.02.001.
- [42] A. Manickam, S. Kamalasadana, D. Edwards, and S. Simmons, “A novel self-evolving intelligent multiagent framework for power system control and protection”, *IEEE Syst. J.*, vol. 8, no. 4, pp. 1086–1095, 2014. DOI: 10.1109/JSYST.2013.2269731.
- [43] H. Wan, K. P. Wong, and C. Y. Chung, “Multi-agent application in protection coordination of power system with distributed generations”, in *Proc. of IEEE Power Energy Soc. Gen. Meet. - Convers. Deliv. Electr. Energy 21st Century*, 2008. DOI: 10.1109/PES.2008.4596261.
- [44] R. Abedini, T. Pinto, H. Morais, and Z. Vale, “Multi-agent approach for power system in a smart grid protection context”, in *Proc. of 2013 IEEE Grenoble Conf.*, 2013, pp. 1–6. DOI: 10.1109/PTC.2013.6652158.
- [45] H. Wan, K. K. Li, and K. P. Wong, “Multi-agent application of substation protection coordination with distributed generators”, in *Proc. of 2005 Int. Conf. Futur. Power Syst.*, vol. 2005, 2005, pp. 1–6. DOI: 10.1109/fps.2005.204251.
- [46] F. M. Cleveland, “IEC 61850-7-420 communications standard for distributed energy resources (DER)”, in *Proc. of IEEE Power Energy Soc. Gen. Meet. - Convers. Deliv. Electr. Energy 21st Century*, 2008, pp. 5–8. DOI: 10.1109/PES.2008.4596553.
- [47] T. J. Hammons, “Integrating renewable energy sources into European grids”, *Int. J. Electr. Power Energy Syst.*, vol. 30, no. 8, pp. 462–475, 2008. DOI: 10.1016/j.ijepes.2008.04.010.
- [48] T. S. Ustun, M. A. Aftab, I. Ali, and S. M. S. Hussain, “A novel scheme for performance evaluation of an IEC 61850-based active distribution system substation”, *IEEE Access*, vol. 7, pp. 123893–123902, 2019. DOI: 10.1109/ACCESS.2019.2937971.
- [49] T. S. Ustun and S. M. Suhail Hussain, “Implementation of IEC 61850 based integrated EV charging management in smart grids”, in *Proc. of 2019 IEEE Veh. Power Propuls. Conf. (VPPC)*, 2019, pp. 1–5. DOI: 10.1109/VPPC46532.2019.8952263.
- [50] T. S. Ustun and S. M. Suhail Hussain, “Extending IEC 61850 communication standard to achieve Internet-of-Things in smartgrids”, in *Proc. of 2019 International Conference on Power Electronics, Control and Automation (ICPECA)*, 2020, pp. 1–6. DOI: 10.1109/icpeca47973.2019.8975510.
- [51] T. S. Ustun and S. M. Suhail Hussain, “Implementation and performance evaluation of IEC 61850 based home energy management system”, in *Proc. of 2019 IEEE 8th Glob. Conf. Consum. Electron.*, 2020, pp. 24–25. DOI: 10.1109/GCCE46687.2019.9015222.

- [52] T. S. Ustun, S. M. Farooq, and S. M. S. Hussain, "A novel approach for mitigation of replay and masquerade attacks in smartgrids using IEC 61850 Standard", *IEEE Access*, vol. 7, pp. 156044–156053, 2019. DOI: 10.1109/ACCESS.2019.2948117.
- [53] T. S. Ustun, C. Ozansoy, and A. Zayegh, "Modeling of a centralized microgrid protection system and distributed energy resources according to IEC 61850-7-420", *IEEE Trans. Power Syst.*, vol. 27, no. 3, pp. 1560–1567, 2012. DOI: 10.1109/TPWRS.2012.2185072.
- [54] A. Barbato, "Sustainable Energy, Grids and Networks IEC 61850-based adaptive protection system for the MV distribution", *Sustain. Energy, Grids Networks*, vol. 15, pp. 26–33, 2018. DOI: 10.1016/j.segan.2017.09.003.



This article is an open access article distributed under the terms and conditions of the Creative Commons Attribution 4.0 (CC BY 4.0) license (<http://creativecommons.org/licenses/by/4.0/>).