

AFML-TR-74-13

**AN ALTERNATE GRAPHICAL REPRESENTATION
OF FAILURE SURFACE**

*H. T. HAHN
S. W. TSAI*

TECHNICAL REPORT AFML-TR-74-13

MAY 1974

Approved for public release; distribution unlimited.

19960412 035

AIR FORCE MATERIALS LABORATORY
AIR FORCE SYSTEMS COMMAND
WRIGHT-PATTERSON AIR FORCE BASE, OHIO 45433

PLASTECC
21799

DISTRIBUTION STATEMENT A
Approved for public release;
Distribution Unlimited

DTIC QUALITY INSPECTED 1

NOTICE

When Government drawings, specifications, or other data are used for any purpose other than in connection with a definitely related Government procurement operation, the United States Government thereby incurs no responsibility nor any obligation whatsoever; and the fact that the government may have formulated, furnished, or in any way supplied the said drawings, specifications, or other data, is not to be regarded by implication or otherwise as in any manner licensing the holder or any other person or corporation, or conveying any rights or permission to manufacture, use, or sell any patented invention that may in any way be related thereto.

Copies of this report should not be returned unless return is required by security considerations, contractual obligations, or notice on a specific document.

AFML-TR-74-13

AN ALTERNATE GRAPHICAL REPRESENTATION
OF FAILURE SURFACE

H. T. HAHN
S. W. TSAI

Approved for public release; distribution unlimited.

FOREWORD

This report was prepared by H. T. Hahn and S. W. Tsai of the Mechanics and Surface Interactions Branch, Nonmetallic Materials Division, Air Force Materials Laboratory, Wright-Patterson Air Force Base, Ohio 45433. The work was conducted under Project 7342, "Fundamental Research on Macromolecular Materials and Lubrication Phenomena", Task 734202, "Studies on the Structure-Property Relationships of Polymeric Materials". The program was administered by the Air Force Materials Laboratory.

The research reported occurred from August 1973 through November 1973. This report was released by the authors in November 1973 for publication.

This technical report has been reviewed and is approved for publication.

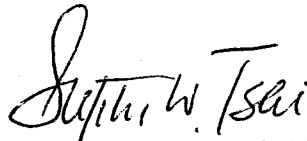

STEPHEN W. TSAI, Acting Chief
Mechanics & Surface Interactions Branch
Nonmetallic Materials Division
Air Force Materials Laboratory

ABSTRACT

Failure surface of laminated composites can be constructed in special strain space such that the transformation of strain components becomes an orthogonal matrix. This construction provides a convenient means of studying strength of laminates consisting of arbitrary lamina orientations. This special construction of failure surface can be based on the maximum strain theory, the tensor polynomial theory or other failure criteria of the lamina. The effect of nonlinearity due to shear on the failure surface is also illustrated.

TABLE OF CONTENTS

SECTION	PAGE
I INTRODUCTION	1
II METHOD	3
III APPLICATIONS	12
1. Unidirectional Laminae	12
2. Laminated Composites	25
IV COMPARISON BETWEEN STRESS AND STRAIN FAILURE CRITERIA	33
V SUMMARY	39
REFERENCES	41
APPENDIX I MODIFIED STRENGTH TENSOR COMPONENTS	44
APPENDIX II USE OF FAILURE SURFACES IN q-r PLANE	45

LIST OF ILLUSTRATIONS

FIGURE		PAGE
1	Coordinate Transformation	4
2	p, q, r in Mohr's Circle	6
3	Relation Between (\bar{e}_1, \bar{e}_2) and (p, q)	7
4	Induced Transformation of (q, r)	8
5	Change of Failure Surface; Deformation and Rotation	10
6	Maximum Strain Failure Surface for High-Strength Graphite/Epoxy	16
7	Maximum Strain Failure Surface for Intermediate- Strength Graphite/Epoxy	17
8	Maximum Strain Failure Surface for High-Modulus Graphite/Epoxy	18
9	Maximum Strain Failure Surface for Boron/Epoxy . .	19
10	Polynomial Failure Surface for Glass/Epoxy Scotch- Ply 1002	24
11	Failure Surfaces of Boron/Epoxy Lamina as Independent Layers	31
12	Failure Surfaces of Boron/Epoxy Lamina as Constituent Layers in $[0^\circ/\pm 30^\circ]_s$ Laminate	32
13	Comparison Between Stress and Strain Criteria; $\sigma_1 - \sigma_6$ Plane	37
14	Comparison Between Stress and Strain Criteria; $\sigma_2 - \sigma_6$ Plane	38

SECTION I
INTRODUCTION

In the design of composites it is frequently necessary to know the failure properties referred to a reference coordinate system other than the material coordinates. A failure surface is usually constructed in the stress or strain coordinates which are the components referred to the material symmetry axes. When a different coordinate system is used, the resulting failure surface cannot be obtained from the original one through a pure rotation, because the matrix relating the stress or strain components in the two different coordinates is not orthogonal. In other words, the transformation of stress or strain components involves a deformation as well as a rotation, which follows easily from the Polar Decomposition Theorem.

Rotation is easy to visualize and so amenable to graphical representation. We described in Reference 1 a method to eliminate the deformation part from the transformation matrix. What makes this possible is the similarity of the transformation matrix to an orthogonal matrix. Here we apply the method to study failure surfaces of symmetric laminated composites subjected to in-plane loadings only. A full advantage is taken of the orthogonality of the modified transformation matrix. Further, noting that this orthogonal matrix describes a rotation about the axis of two

dimensional dilatational strain p in the modified strain coordinates (or hydrostatic stress in the modified stress coordinates), it is proposed to represent the failure surface in the $(e_1 - e_2)/2 - e_6/2$ plane with p as a parameter. An advantage of the proposed method is shown via its application to analysis of initial failure of a laminate.

Stress-strain relation of most unidirectional laminae can be assumed to be linear except in shear. A comparison is given, with due regard to this shear nonlinearity, between the stress and strain criteria of failure when they both are described by polynomials of second order.

SECTION II

METHOD

It was suggested in Reference 1 to use $\sqrt{2} \sigma_6^+$ in place of the shear stress σ_6 because this makes the transformation matrix of stress orthogonal. The same result was shown to follow for strain if e_6 is replaced by $e_6/\sqrt{2}$. A new set of coordinates $(\bar{\sigma}_1^*, \bar{\sigma}_2^*, \bar{\sigma}_6^*)$ was introduced in which the transformation describes a rotation about $\bar{\sigma}_1^*$ axis through an angle -2θ , where θ is the angle of rotation of coordinates (χ_1, χ_2) Figure 1.

The modified strain components \bar{e}_i^* are related to the original components e_i by

$$\begin{aligned}\bar{e}_1^* &= (e_1 + e_2)/\sqrt{2}, \\ \bar{e}_2^* &= -(e_1 - e_2)/\sqrt{2}, \\ \bar{e}_6^* &= e_6/\sqrt{2}.\end{aligned}\tag{1}$$

To make terms on the right side more familiar we divide them by $\sqrt{2}$ to obtain

$$\underline{e}^o = (p, q, r)^T = \underline{\underline{H}} \underline{e}\tag{2}$$

⁺ Contracted notation is used.

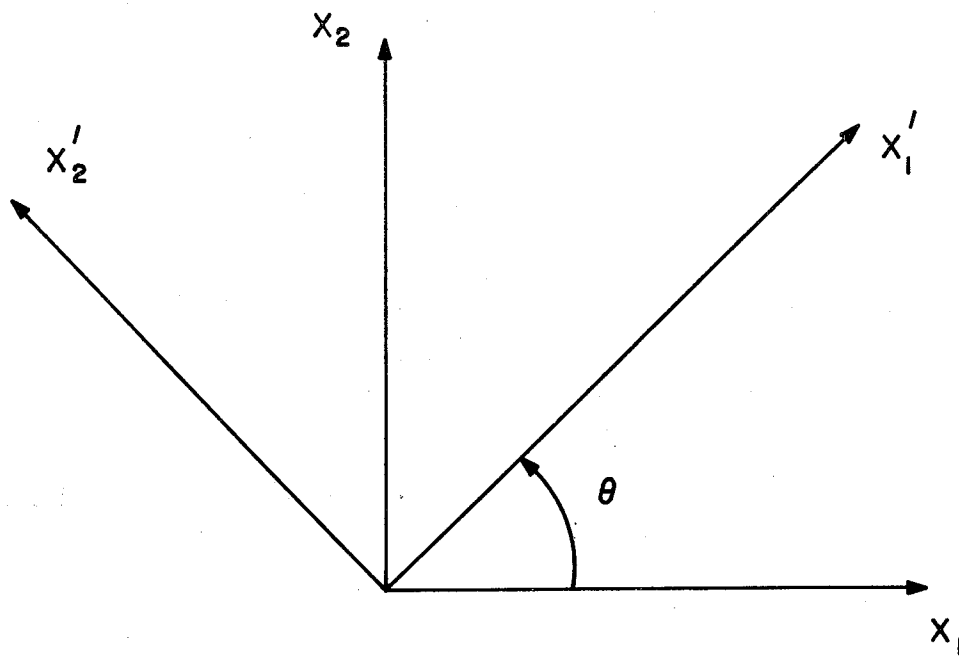

Figure 1. Coordinate Transformation

where

$$\tilde{H} = \frac{1}{2} \begin{bmatrix} 1 & 1 & 0 \\ 1 & -1 & 0 \\ 0 & 0 & 1 \end{bmatrix} \quad \tilde{H}^{-1} = \begin{bmatrix} 1 & 1 & 0 \\ 1 & -1 & 0 \\ 0 & 0 & 2 \end{bmatrix} \quad (3)$$

Note that the coordinate system (p, q, r) is left-handed.

Quantities p, q, r given by

$$p = (e_1 + e_2)/2, \quad q = (e_1 - e_2)/2, \quad r = e_6/2, \quad (4)$$

are all familiar if we consider the Mohr's circle representation of a strain state, Figure 2. Moreover, we can specify (e_1, e_2) and (p, q) in the same coordinate plane if we change the scale of e_1 and e_2 by

$$\bar{e}_1 = e_1/\sqrt{2}, \quad \bar{e}_2 = e_2/\sqrt{2}. \quad (5)$$

The relation is shown graphically in Figure 3. Transformation of the modified coordinates (p, q, r) follows from that of (e_1, e_2, e_6) :

$$\begin{Bmatrix} p' \\ q' \\ r' \end{Bmatrix} = \begin{bmatrix} 1 & 0 & 0 \\ 0 & \cos 2\theta & \sin 2\theta \\ 0 & -\sin 2\theta & \cos 2\theta \end{bmatrix} \begin{Bmatrix} p \\ q \\ r \end{Bmatrix} \quad (6)$$

where primed quantities are referred to new coordinates (χ_1, χ_2) .

Equation (6) is nothing but a simple coordinate transformation showing that (p', q', r') is related to (p, q, r) through a rotation of angle 2θ about p axis, Figure 4.

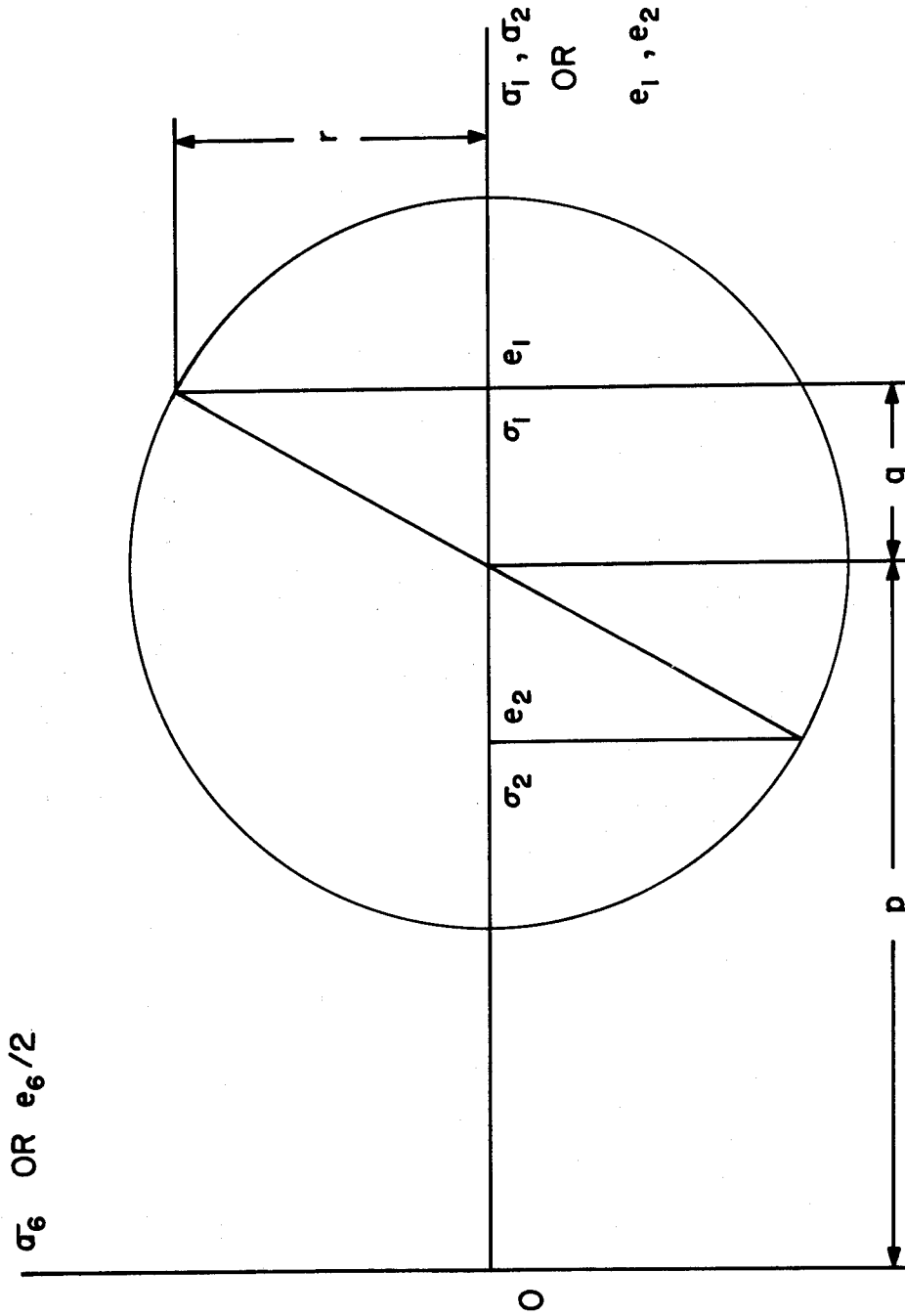

Figure 2. p, q, r in Mohr's Circle

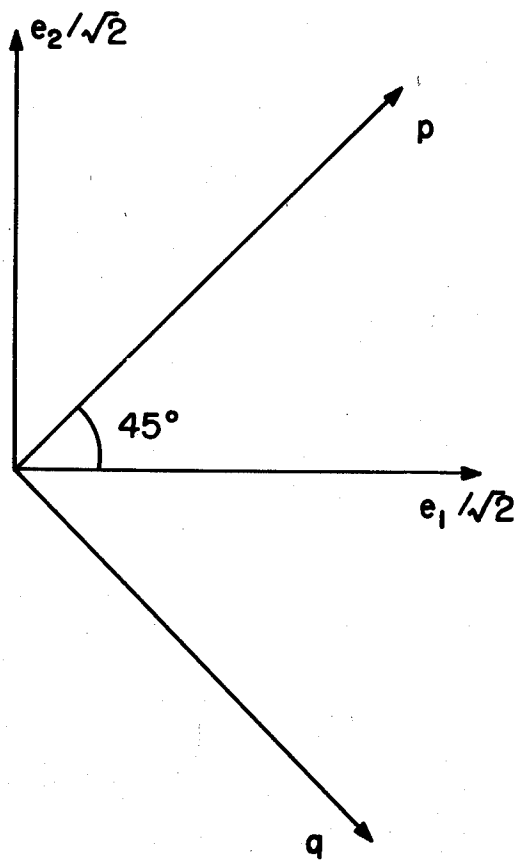

Figure 3. Relation Between (\bar{e}_1, \bar{e}_2) and (p, q)

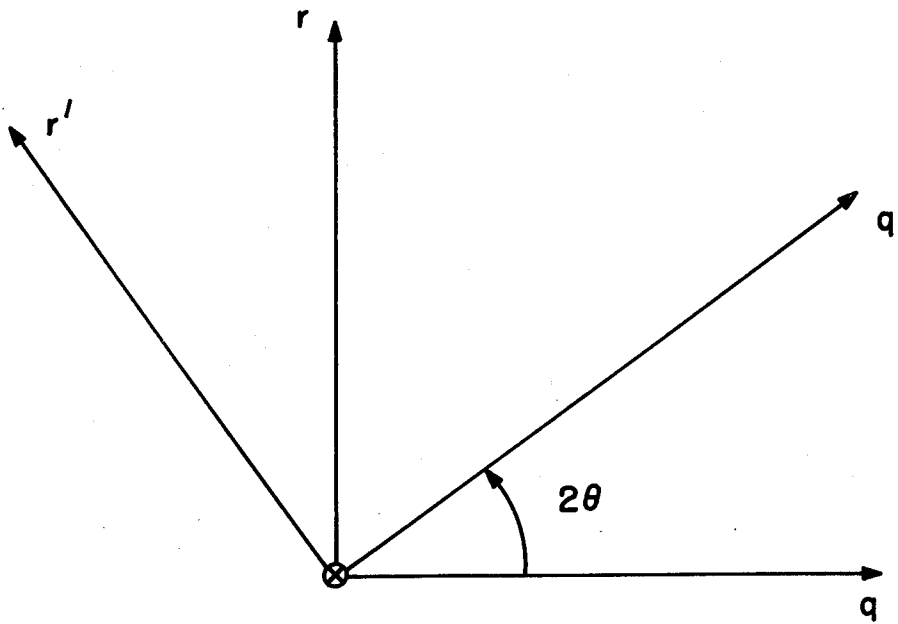

Figure 4. Induced Transformation of (q, r)

Failure is characterized by a closed surface in the stress or strain coordinates. Transformation between e_i' and e_i , for example, includes a deformation as well as a rotation. Therefore, the shape of failure surface is altered by this transformation, Figure 5. However, when the failure surface is drawn in the (p, q, r) coordinates, its shape does not change because the coordinate transformation results only in a rotation about the p axis.

Mathematically, a failure surface may be described by a function g such that

$$g(\underline{e}) = 1 \quad (7)$$

The equation for the same surface in the (p, q, r) coordinates is then given by a new function g^o which is related to g by

$$g^o(\underline{e}^o) = g(\underline{H}^{-1}\underline{e}^o) = 1 \quad (8)$$

Equation (8) is useful in obtaining the new function g^o , especially when the surface is described by a polynomial. It should be noted, however, that the method is not restricted to such cases only. A simple graphical method is possible when the maximum strain criterion is used. Figure 6 shows such graphical construction. It also illustrates the way the projection on the q - r plane is obtained. This will be explained in detail in the following section.

The same reduction follows for a failure surface in the stress space if the stress vector $\underline{\sigma} = (\sigma_1, \sigma_2, \sigma_6)^T$ is replaced by

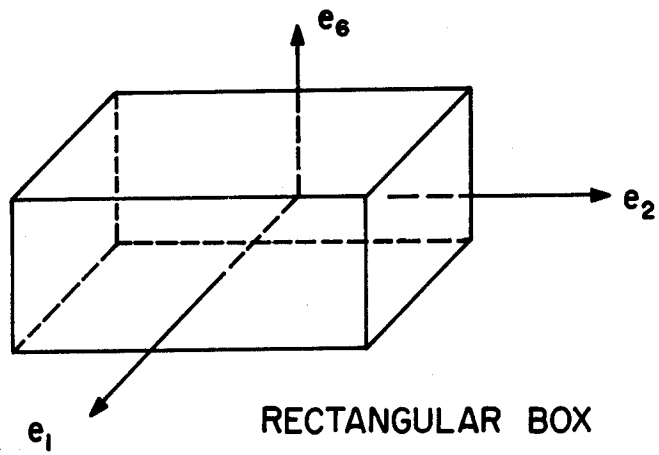

(a)

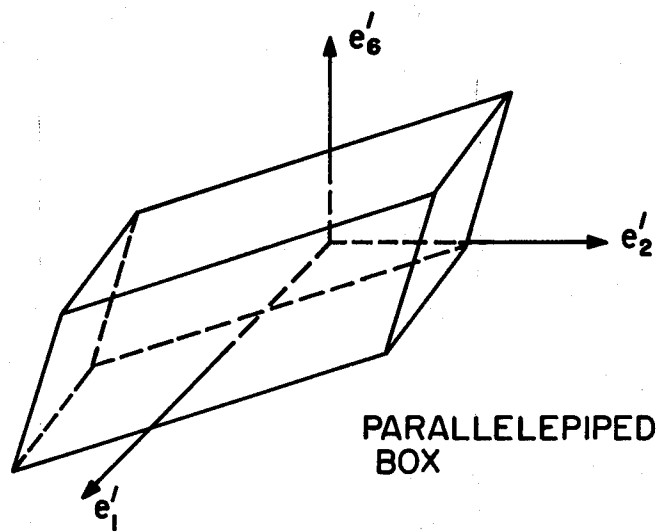

(b)

Figure 5. Change of Failure Surface; Deformation and Rotation

$$\underline{\sigma}^o = (p, q, r)^T = \underline{\underline{K}} \underline{\underline{g}} \quad (9)$$

where

$$\underline{\underline{K}} = \frac{1}{2} \begin{bmatrix} 1 & 1 & 0 \\ 1 & -1 & 0 \\ 0 & 0 & 2 \end{bmatrix} \quad \underline{\underline{K}}^{-1} = \begin{bmatrix} 1 & 1 & 0 \\ 1 & -1 & 0 \\ 0 & 0 & 1 \end{bmatrix} \quad (10)$$

Our discussion is hereafter restricted to strain criteria because our main objective is to apply the method to laminated composites in the framework of classical plate theory.

SECTION III
APPLICATIONS

1. UNIDIRECTIONAL LAMINAE

There are various criteria for failure of composites. These theories are summarized in Reference 2. Although the present method is not restricted to any particular criteria, we restrict our discussion to the maximum strain criterion and the second order tensor polynomial criterion.

In the maximum strain criterion, the allowable range of strains are given by

$$\begin{aligned} E_1^+ \geq e_1 \geq E_1^-, & \quad E_2^+ \geq e_2 \geq E_2^-, \\ E_6^+ \geq e_6 \geq E_6^- & \end{aligned} \quad (11)$$

In the modified coordinates $(\bar{e}_1, \bar{e}_2, r)$ the corresponding limit values are

$$\begin{aligned} E_1^+/\sqrt{2} \geq \bar{e}_1 \geq E_1^-/\sqrt{2}, & \quad E_2^+/\sqrt{2} \geq \bar{e}_2 \geq E_2^-/\sqrt{2}, \\ E_6^+/2 \geq r \geq E_6^-/2 & \end{aligned} \quad (12)$$

Equation (11) implies the absence of interaction among limiting strain components. Therefore, it is possible to obtain those limiting values from the limiting stress components determined by load-controlled tests if pertinent constitutive equation is known. Most composites are almost

linear up to failure in longitudinal and transverse tension and compression. Thus, it follows that

$$\begin{aligned} E_1^+ &= X_1^+/E_L, & E_1^- &= X_1^-/E_L, \\ E_2^+ &= X_2^+/E_T, & E_2^- &= X_2^-/E_T, \end{aligned} \quad (13)$$

where X_1 and X_2 are the failure stresses and E_L and E_T are the longitudinal and transverse Young's moduli, respectively (Reference 3).

The difficulty in relating the limiting strain components to the limiting stress components lies in shear, because of highly nonlinear behavior. The procedure we follow here is derived from current practice which chooses a fictitious maximum strain assuming a linear behavior. This may be plausible if we note that the classical theory of laminated composites is based on the linear stress-strain relation. A recent study (References 4, 5) showed that the effect of shear nonlinearity on the behavior of laminates is negligible under uniaxial tension as far as laminates contain layers of 0° orientation. The nonlinearity appears most in $\pm 45^\circ$ laminate as experimentally observed and theoretically proved. In any event we here choose the truncated value as the limiting shear strain so that

$$E_6^+ = -E_6^- = X_6/G \quad (14)$$

where, again, X_6 is the failure stress and G is the shear modulus. The first equality which states the identity of positive and negative shears follows from the material symmetry of unidirectional laminae.

Failure stresses of unidirectional graphite/epoxy and boron/epoxy composites are given in Reference 6 . The corresponding strains are determined using Equations 13 and 14, and are listed in Table I. Graphical representation of failure surfaces is given in Figures 6 through 9.

The procedure to be followed is described below:

- a. Obtain limiting values of e_1 , e_2 , e_6 directly from experiment or from limiting stress components through Equations 13 and 14.
- b. Calculate limiting values of \bar{e}_1 , \bar{e}_2 , r from Equation 12.
- c. Draw the failure surface in the \bar{e}_1 - \bar{e}_2 plane.
- d. Draw p and q axes. p axis bisects the angle $\angle \bar{e}_1 o \bar{e}_2$ and q axis the angle $\angle \bar{e}_1 o (-\bar{e}_2)$.
- e. To find the failure surface in the q - r plane corresponding to a particular value $p = c$, draw a straight line $p = c$. The points at which this line intersects the failure surface in the p - q plane give the limiting values of q .
- f. The corresponding failure surface is then given as a rectangle whose vertical sides pass through those determined points on the q axis and whose horizontal sides are given by $r = E_6^+/2$ and $r = E_6^-/2$.

Another way of characterizing the failure of unidirectional composites is provided by a second order tensor polynomial of the form (Reference 7)*

* Summation is implied over any repeated indices.

TABLE I
LIMIT VALUES OF STRAINS

Material \ Failure strain	E_1^+ $\times 10^3$	$-E_1^-$ $\times 10^3$	E_2^+ $\times 10^3$	$-E_2^-$ $\times 10^3$	E_6 $\times 10^3$
High-Strength Graphite/Epoxy $v_f = 0.6$	8.57	8.57	4.71	17.65	18.46
Intermediate-Strength Graphite/Epoxy $v_f = 0.6$	9.41	9.41	4.41	14.71	15.38
High-Modulus Graphite/Epoxy $v_f = 0.6$	4.40	4.00	2.35	11.76	13.85
Boron/Epoxy $v_f = 0.5$	6.40	11.77	3.85	14.81	21.86

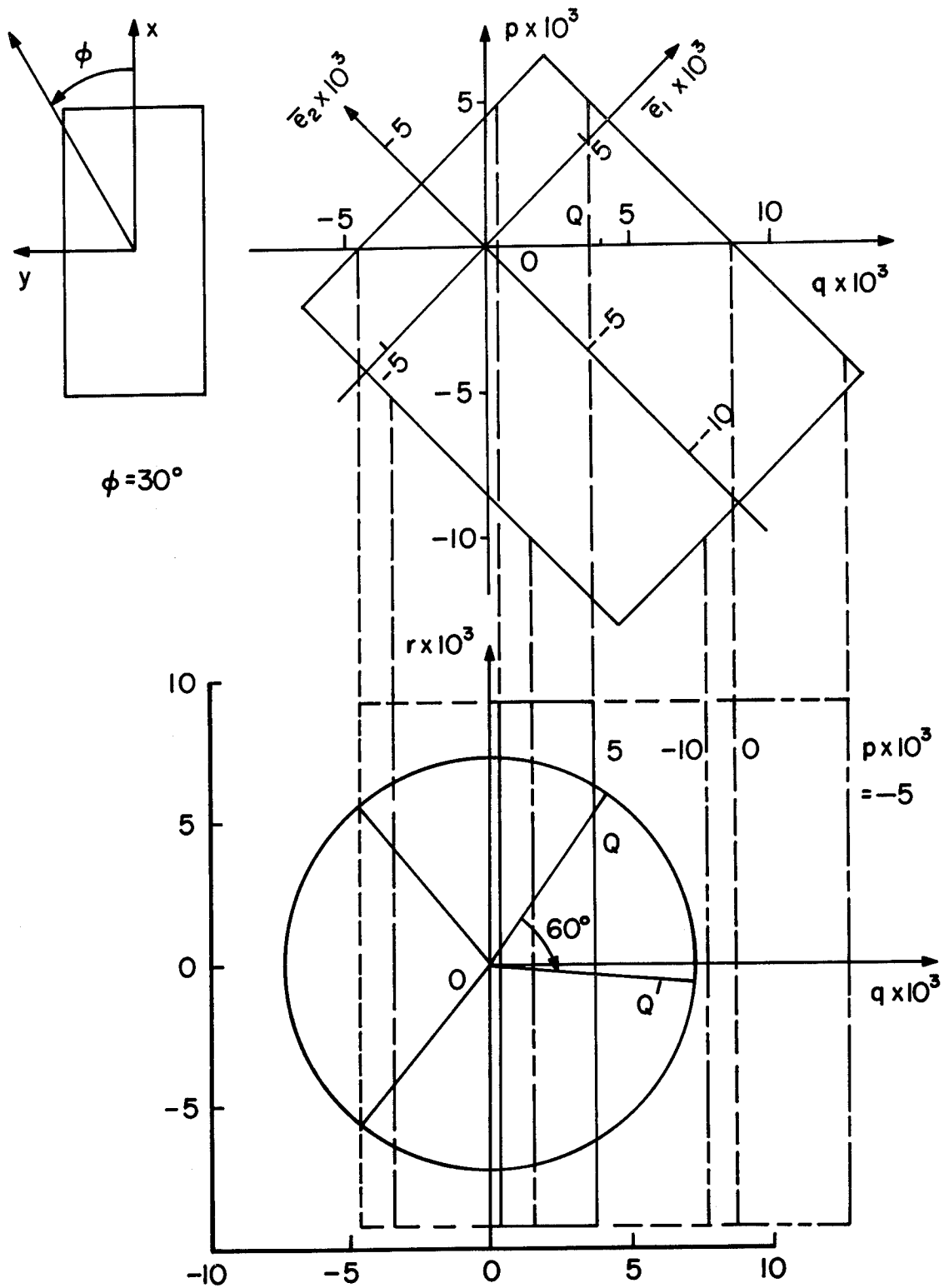

Figure 6. Maximum Strain Failure Surface for High-Strength Graphite/Epoxy

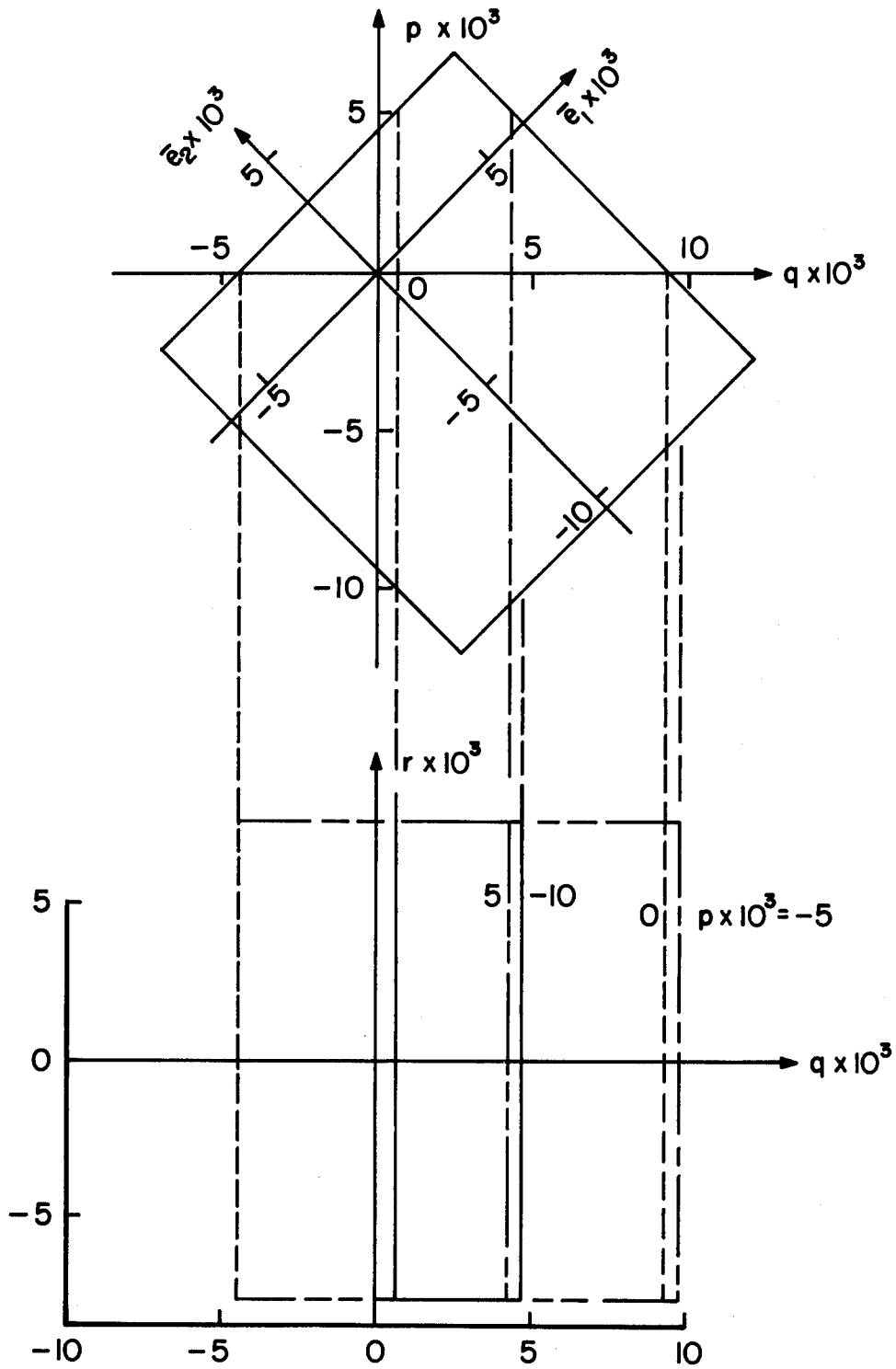

Figure 7. Maximum Strain Failure Surface for Intermediate-Strength Graphite/Epoxy

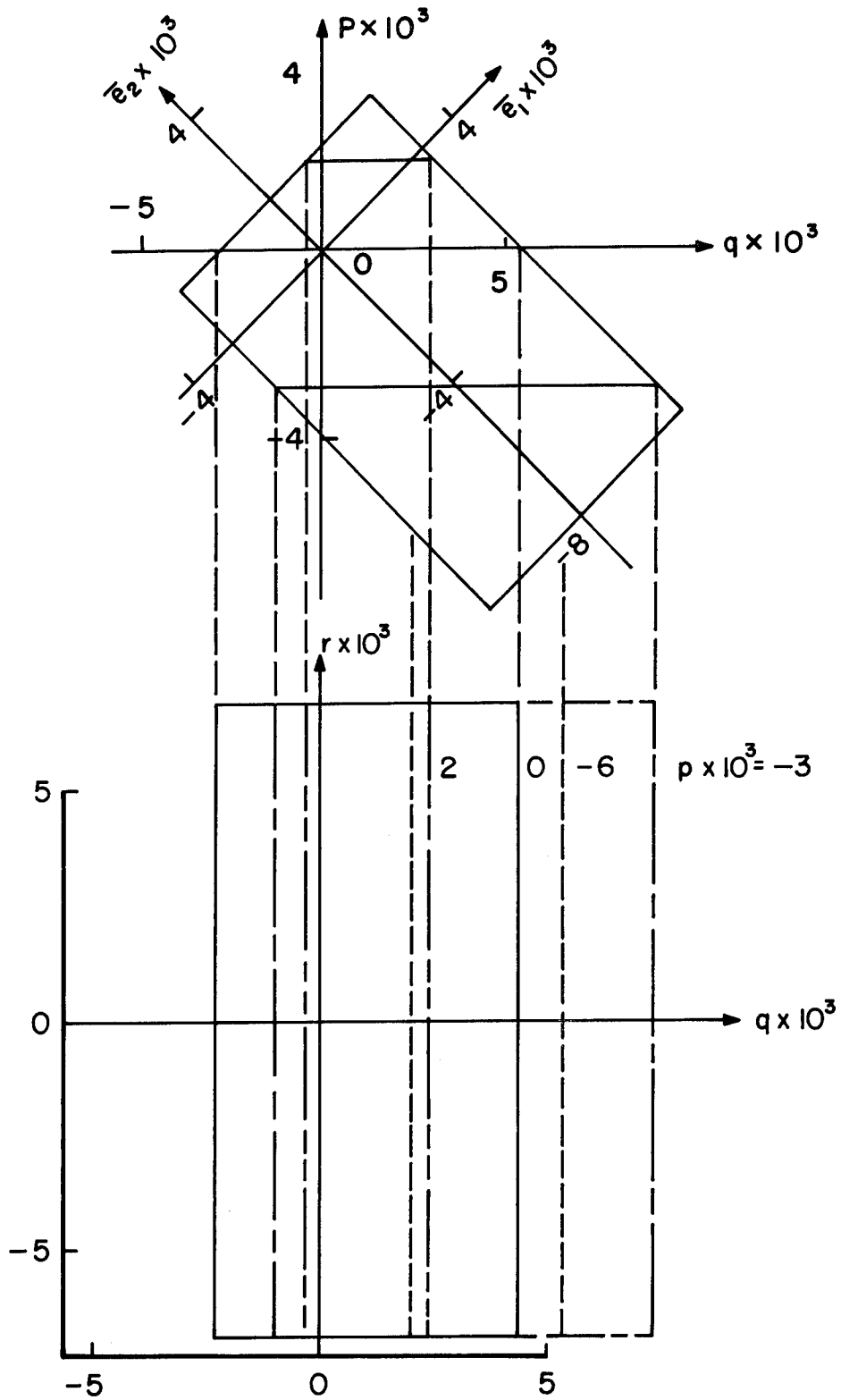

Figure 8. Maximum Strain Failure Surface for High-Modulus Graphite/Epoxy

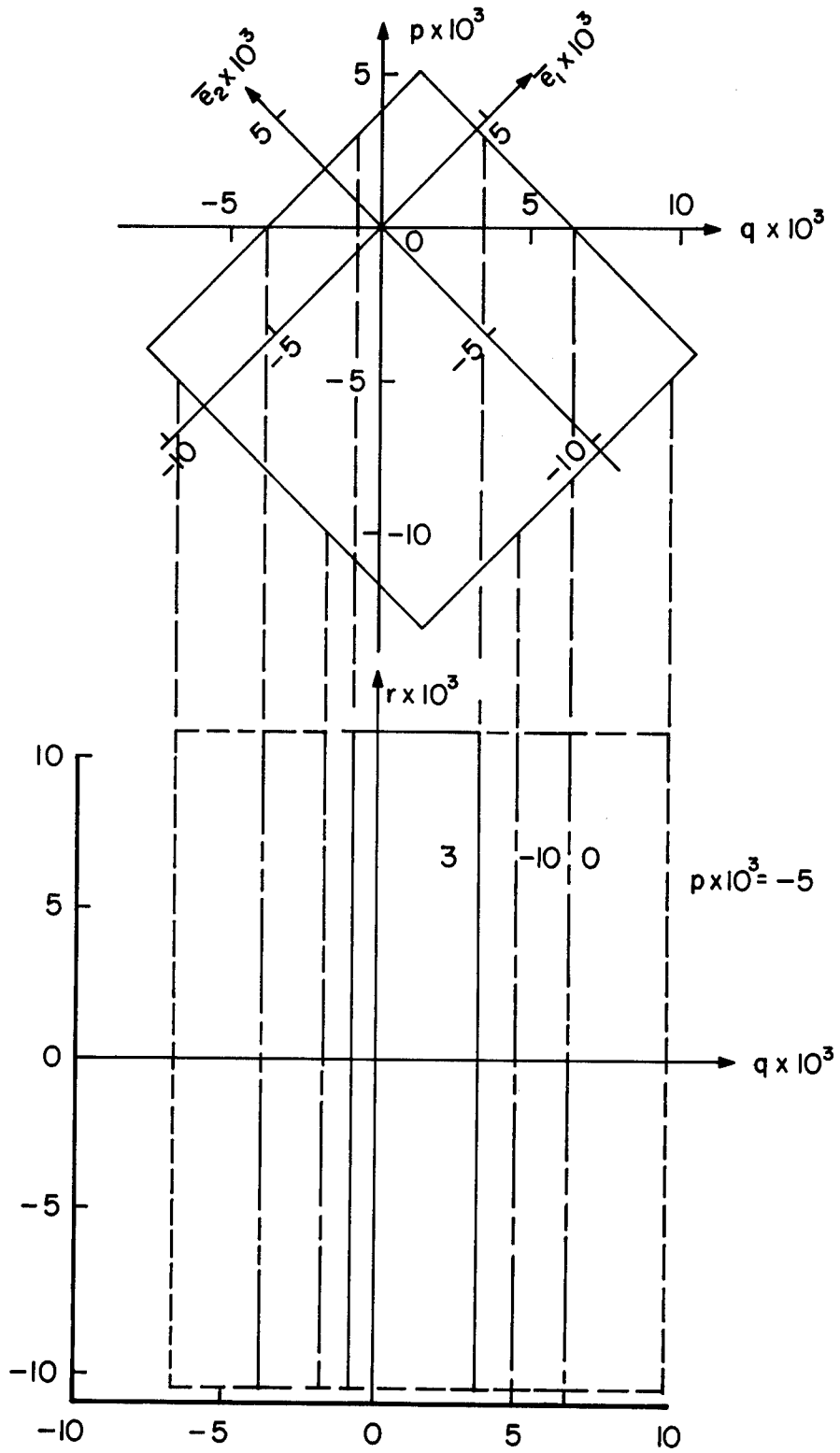

Figure 9. Maximum Strain Failure Surface for Boron/Epoxy

$$g(\underline{e}) = G_i e_i + G_{ij} e_i e_j = 1 \quad (15)$$

In the modified strain coordinates the same failure surface is described by a new function g^o

$$g^o(\underline{e}^o) = G_i^o e_i^o + G_{ij}^o e_i^o e_j^o = 1 \quad (16)$$

where

$$G_i^o = H_{ji}^{-1} G_j, \quad G_{ij}^o = H_{ki}^{-1} H_{lj}^{-1} G_{kl} \quad (17)$$

Using Equation (3) for the matrix H_{ij}^{-1} in Equation (17) results in

$$\begin{Bmatrix} G_1^o \\ G_2^o \\ G_6^o \end{Bmatrix} = \begin{Bmatrix} G_1 + G_2 \\ G_1 - G_2 \\ 2G_6 \end{Bmatrix}, \quad (18)$$

$$[G_{ij}^o] = \begin{bmatrix} G_{11} + 2G_{12} + G_{22} & G_{11} - G_{22} & 2(G_{16} + G_{26}) \\ & G_{11} - 2G_{12} + G_{22} & 2(G_{16} - G_{26}) \\ \text{symmetric} & & 4G_{66} \end{bmatrix}$$

For unidirectional laminae the material symmetry requires that

$$G_6 = G_{16} = G_{26} = 0 \quad (19)$$

Therefore, Equation (16) reduces to

$$\frac{(q - q_p)^2}{a^2} + \frac{r^2}{b^2} = 1 \quad (20)$$

where

$$a^2 = \frac{1}{G_{22}^0} k_p^2 \quad b^2 = \frac{1}{G_{66}^0} k_p^2$$

$$q_p = -\frac{1}{2G_{22}^0} (2G_{12}^0 p + G_2^0) \quad (21)$$

$$k_p^2 = \left[\left(\frac{G_{12}^{0^2}}{G_{22}^0} - G_{11}^0 \right) p^2 + \left(\frac{G_{12}^0 G_2^0}{G_{22}^0} - G_1^0 \right) p + \frac{G_2^{0^2}}{4G_{22}^0} + 1 \right]$$

Since a failure surface should be closed from physical considerations,

Equation (20) should describe an ellipse and so

$$a^2 > 0, \quad b^2 > 0, \quad \infty > k_p^2 \geq 0 \quad (22)$$

The ratio of major axis to minor axis remains constant whereas the center moves along q axis depending on the value of p . The lengths of axes also depend on p . In terms of G_{ij}^0 Equation (22) yields the well known conditions

$$G_{11}^0 G_{22}^0 > G_{12}^{0^2}, \quad G_{22}^0 G_{66}^0 > 0 \quad (23)$$

and

$$G_1^{0^2} + G_{11}^0 G_2^{0^2} / G_{22}^0 + 4G_{11}^0 - 2G_{12}^0 (G_1^0 G_2^0 + 2G_{12}^0) / G_{22}^0 \geq 0 \quad (24)$$

The bounds for p then follow as

$$P_{\min} \leq p \leq P_{\max}, \quad (25)$$

$$p_{\min} = (B - C)/(2A), \quad p_{\max} = -(B + C)/(2A) \quad (25)$$

Cont'd.

where

$$A = G_{12}^{\circ 2}/G_{22}^{\circ} - G_{11}^{\circ}$$

$$B = [G_1^{\circ 2} + G_{11}^{\circ}G_2^{\circ 2}/G_{22}^{\circ} + 4G_{11}^{\circ} - 2G_{12}^{\circ}(G_1^{\circ}G_2^{\circ} + 2G_{12}^{\circ})/G_{22}^{\circ}]^{1/2} \quad (26)$$

$$C = G_2^{\circ}G_{12}^{\circ}/G_{22}^{\circ} - G_1^{\circ}$$

The strength tensors G_i , G_{ij} in the strain criterion can be related to the strength tensors F_i , F_{ij} in the stress criterion if the material is linear elastic (Appendix I):

$$G_i = Q_{ji}F_j, \quad G_{ij} = Q_{ki}Q_{lj}F_{kl} \quad (27)$$

where Q_{ij} is the reduced stiffness tensor. The above equation is necessary because most available data are for F_i and F_{ij} .

As an example we take the failure data reported in Reference 8 for glass/epoxy scotch-ply 1002 lamina:

$$F_1 = -0.003 \text{ (ksi)}^{-1}, \quad F_2 = 0.295 \text{ (ksi)}^{-1},$$

$$F_{11} = 0.063 \times 10^{-3} \text{ (ksi)}^{-2}, \quad F_{22} = 17.15 \times 10^{-3} \text{ (ksi)}^{-2}, \quad (28)$$

$$F_{66} = 10.85 \times 10^{-3} \text{ (ksi)}^{-2}, \quad F_{12} = 0.15 \times 10^{-3} \text{ (ksi)}^{-2}$$

The stiffness matrix of the same material is

$$[Q_{ij}] = \begin{bmatrix} 5.004 & 0.083 & 0 \\ 0.083 & 1.668 & 0 \\ 0 & 0 & 0.704 \end{bmatrix} \times 10^3 \text{ ksi} \quad (29)$$

From Equation (27) follow G_i and G_{ij} :

$$\begin{aligned} G_1 &= 9.475 & G_2 &= 491.81 \\ G_{11} &= 1.82 \times 10^3 & G_{22} &= 47.76 \times 10^3 \\ G_{66} &= 5.38 \times 10^3 & G_{12} &= 3.65 \times 10^3 \end{aligned} \quad (30)$$

Finally, substituting Equation (30) into Equation (18) yields

$$\begin{aligned} G_1^0 &= 510.29 & G_2^0 &= -482.34 \\ G_{11}^0 &= 56.88 \times 10^3 & G_{22}^0 &= 42.27 \times 10^3 \\ G_{66}^0 &= 21.51 \times 10^3 & G_{12}^0 &= -45.94 \times 10^3 \end{aligned} \quad (31)$$

The variables characterizing the failure surface can now be obtained by substituting the above data into Equation (21):

$$\begin{aligned} a &= 4.864 \times 10^{-3} k_p, & b &= 6.818 \times 10^{-3} k_p, \\ q_p &= 1.087 p + 5.705 \times 10^{-3}, \\ k_p &= (-6.951 \times 10^3 p^2 + 22.928 p + 2.376)^{1/2}. \\ p_{\min} &= -16.91 \times 10^{-3}, & p_{\max} &= 20.21 \times 10^{-3} \end{aligned} \quad (32)$$

The failure surface is drawn on the q - r plane, Figure 10. Each ellipse represents Equation (20) for a fixed dilatational strain p .

It goes without saying that, whereas the graphical method is a more viable means of constructing failure surface in the case of maximum strain (or stress) criterion, one has to resort to the equation of failure in the case of polynomial criterion (Equation 15).

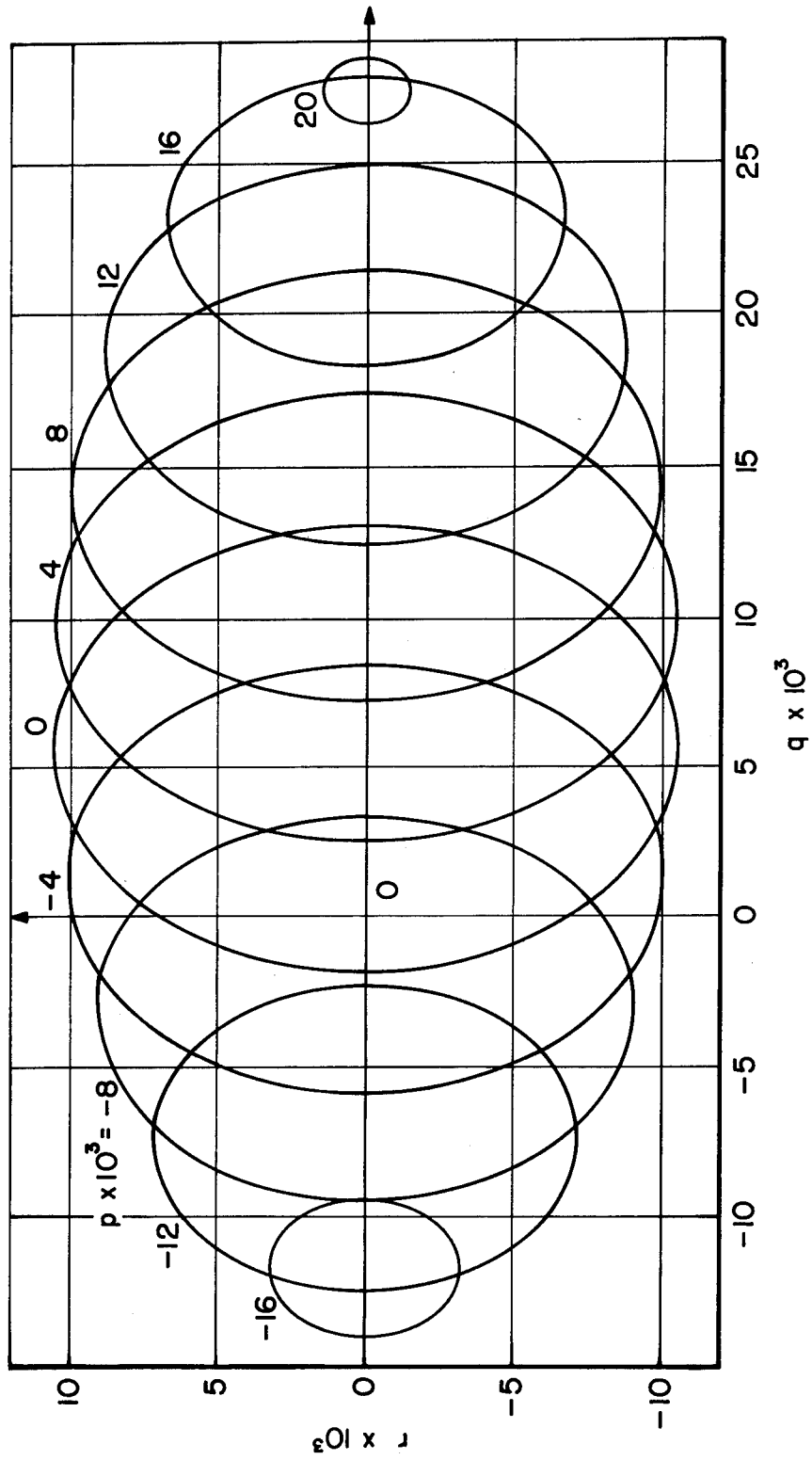

Figure 10. Polynomial Failure Surface for Glass/Epoxy Scotch-Ply 1002

Now that one has the appropriate failure surface drawn in the q-r plane, any off-axis failure can easily be checked. This will be illustrated in the following paragraph.

2. LAMINATED COMPOSITES

According to the classical plate theory for thin laminates, the in-plane strains are assumed to be the same in all constituent layers. This makes it possible to draw failure surface for each layer in the same strain coordinates without modification. Once the state of critical strain is known, the state of stress in each layer can be calculated by using appropriate constitutive equations, e.g., $\sigma_i = Q_{ij}e_j$.

The above argument applies at most to the initial failure of laminate, i.e., the failure of the weakest layer in the laminate. The behavior after the initial failure is not well understood at this time. One of the approaches to this problem is to remove the layers that have failed from the laminate by setting the stiffness of the layers equal to zero (Reference 9); the other assumes stress-strain relations with negative slope for the failed layers (Reference 10). In any event, understanding of the initial failure is important because it forms one of the bases of current design criteria (References 6, 11).

One more point to be noted is that we do not consider any effects of interlaminar stresses. The interlaminar stresses become significant along free edges because there they have large magnitude, depending on the stacking sequence or lay-up of the laminae (References 12, 13). However, a few

thicknesses of the laminate away from the free edges the classical plate theory provides a reasonable solution.

To be precise we formulate the criterion for the initial failure as follows (Reference 14): Let g_a be the failure function of a-th layer. Then the initial failure of laminate occurs when the strain e satisfies the condition

$$\max_a \{ g_a(e) \} = 1 \quad (33)$$

Graphically, this is the equation for the inner envelope of failure surfaces of constituent layers.

As we have seen, the failure surface of, e.g., ϕ^0 layer is obtained from the failure surface of 0^0 layer by keeping the surface fixed while rotating q, r axes through angle -2ϕ . Note that the layer orientation angle ϕ is equal to $-\theta$, because θ is measured away from the layer symmetry axes (Figure 6).

As an illustration consider a high-strength graphite/epoxy laminate of $[0^0/30^0]_s$ lay-up configuration. The lamina failure surface is shown for the 0^0 layer in Figure 6. Suppose the state of strain resulting from stress analysis is

$$e_x = 4 \times 10^{-3}, \quad e_y = -4 \times 10^{-3}, \quad e_{xy} = 12 \times 10^{-3} \quad (34)$$

The corresponding p, q, r follow from Equation 4 by using the above values:

$$\begin{aligned}
 p &= (e_x + e_y)/2 = 0, & q &= (e_x - e_y)/2 = 4 \times 10^{-3}, \\
 r &= e_{xy}/2 = 6 \times 10^{-3} & & (35)
 \end{aligned}$$

The state of strain is denoted by the point Q for the 0° layer. Since we use the same failure surface, the same state of strain is given, for the 30° layer, by the point Q' that is obtained by rotating \overline{OQ} through angle -60° . The failure surface corresponding to $p = 0$ is shown by dashed lines. Since both Q and Q' are inside the region enclosed by those dashed lines, both layers will not fail. It is easily seen that under the same state of strain, the range of ϕ without failure is

$$-74^\circ \leq 2\phi \leq 186^\circ, \text{ i.e., } -37^\circ \leq \phi \leq 93^\circ \quad (36)$$

One of the advantages of using (p, q, r) coordinates in conjunction with failure is that one constructs the failure surface only once no matter how many layers a laminate consists of insofar as all the layers are made of the same material.

A disadvantage of working with failure surfaces in the stress coordinates stems from the fact that the lamina stresses vary from layer to layer even when there are no bending effects. Thus the relation between the lamina stresses and the laminate stresses must be known in order to express any failure criterion in terms of the laminate stresses.

In the laminate coordinates, the laminate stress-strain relation is given by Equation 37 (Reference 15).

$$\begin{pmatrix} N_x \\ N_y \\ N_{xy} \end{pmatrix} = [A_{ij}] \begin{pmatrix} e_x \\ e_y \\ e_{xy} \end{pmatrix} \quad (37)$$

where $[A_{ij}]$ is the laminate stiffness matrix. Noting that the strain components in the lamina coordinates are related to those in the laminate coordinates by

$$\begin{pmatrix} e_1 \\ e_2 \\ e_6 \end{pmatrix} = [T_{ij}^e] \begin{pmatrix} e_x \\ e_y \\ e_{xy} \end{pmatrix}, \quad [T_{ij}^e] = \begin{bmatrix} \cos^2 \phi & \sin^2 \phi & (\sin 2\phi)/2 \\ \sin^2 \phi & \cos^2 \phi & -(\sin 2\phi)/2 \\ -\sin^2 \phi & \sin^2 \phi & \cos 2\phi \end{bmatrix} \quad (38)$$

we can obtain the relation between the lamina stresses and the laminate stresses:

$$\begin{pmatrix} \sigma_1 \\ \sigma_2 \\ \sigma_6 \end{pmatrix} = [B_{ij}] \begin{pmatrix} N_x \\ N_y \\ N_{xy} \end{pmatrix}, \quad B_{ij} = Q_{ik} T_{kl}^e A_{lj}^{-1} \quad (39)$$

where $[A_{lj}^{-1}]$ is the inverse matrix of $[A_{lj}]$.

To compare the failure behavior of a lamina as an independent layer and as a constituent layer in a laminate, it is necessary to use the same reference coordinates. Thus we need the equation

$$\begin{pmatrix} \sigma_1 \\ \sigma_2 \\ \sigma_6 \end{pmatrix} = [T_{ij}^\sigma] \begin{pmatrix} \sigma_x \\ \sigma_y \\ \sigma_{xy} \end{pmatrix}, \quad [T_{ij}^\sigma] = \begin{bmatrix} \cos^2 \phi & \sin^2 \phi & \sin 2\phi \\ \sin^2 \phi & \cos^2 \phi & -\sin 2\phi \\ -(\sin 2\phi)/2 & (\sin 2\phi)/2 & \cos 2\phi \end{bmatrix} \quad (40)$$

As an example, we now take a boron/epoxy composite whose stiffness matrix is given in Reference 6

$$[Q_{ij}] = \begin{bmatrix} 30.12 & 0.572 & 0 \\ 0.572 & 2.71 & 0 \\ 0 & 0 & 0.7 \end{bmatrix} \times 10^3 \text{ ksi} \quad (41)$$

For a laminate of $[0^\circ/\pm 30^\circ]_s$ lay-up configuration, the stiffness matrix is calculated to be

$$[A_{ij}] = \begin{bmatrix} 21.941 & 4.183 & 0 \\ 4.183 & 3.667 & 0 \\ 0 & 0 & 4.311 \end{bmatrix} \times 10^3 \text{ ksi} \quad (42)$$

The matrix $[B_{ij}]$ for the 0° layer is obtained by substituting Equations (41) and (42) into Equation 29:

$$[B_{ij}] = \begin{bmatrix} 1.715 & -1.801 & 3.428 \\ -0.147 & 0.906 & -0.248 \\ -0.087 & 0.290 & 0.162 \end{bmatrix} \quad (43)$$

Similarly, we have

$$[B_{ij}] = \begin{bmatrix} 0.795 & 1.264 & 2.969 \\ -0.080 & 0.684 & -0.215 \\ -0.075 & 0.251 & 0.081 \end{bmatrix} \quad (44)$$

for the 30° layer and

$$[B_{ij}] = \begin{bmatrix} 0.795 & 1.264 & -2.969 \\ -0.080 & 0.684 & 0.215 \\ 0.075 & -0.251 & 0.081 \end{bmatrix} \quad (45)$$

for the -30° layer.

For the purpose of comparison, we choose the maximum stress criterion formulated by

$$\begin{aligned} X_1^+ &\geq \sigma_1 \geq X_1^- , & X_2^+ &\geq \sigma_2 \geq X_2^- , \\ X_6 &\geq \sigma_6 \geq -X_6 \end{aligned} \quad (46)$$

For the given boron/epoxy composite, the limit values are

$$\begin{aligned} X_1^+ &= 192 \text{ ksi}, & X_1^- &= -353 \text{ ksi}, \\ X_2^+ &= 10.4 \text{ ksi}, & X_2^- &= -40 \text{ ksi}, \\ X_6 &= 15.3 \text{ ksi} \end{aligned} \quad (47)$$

As an independent layer, failure surfaces are shown in Figure 11 for 0° , $+30^\circ$, and -30° orientations. Since $\sigma_{xy} = 0$ in the case under consideration, and since $X_6^+ = -X_6^- = X_6$, the failure surface for $+30^\circ$ orientation is the same as that for -30° orientation.

Moreover, for $\pm 30^\circ$ orientations the possible failure mode is either transverse or shear failure. In the figures the first letter stands for longitudinal or transverse and the second for tension or compression. S denotes shear.

Failure behavior of the same lamina as a constituent layer in the $[0^\circ/\pm 30^\circ]_s$ laminate is quite different, as shown in Figure 12. Again, $+30^\circ$ and -30° layers behave identically, because $N_{xy} = 0$. Note that even the 0° layer has a failure surface which is rotated as well as deformed from the original shape.

BORON / EPOXY

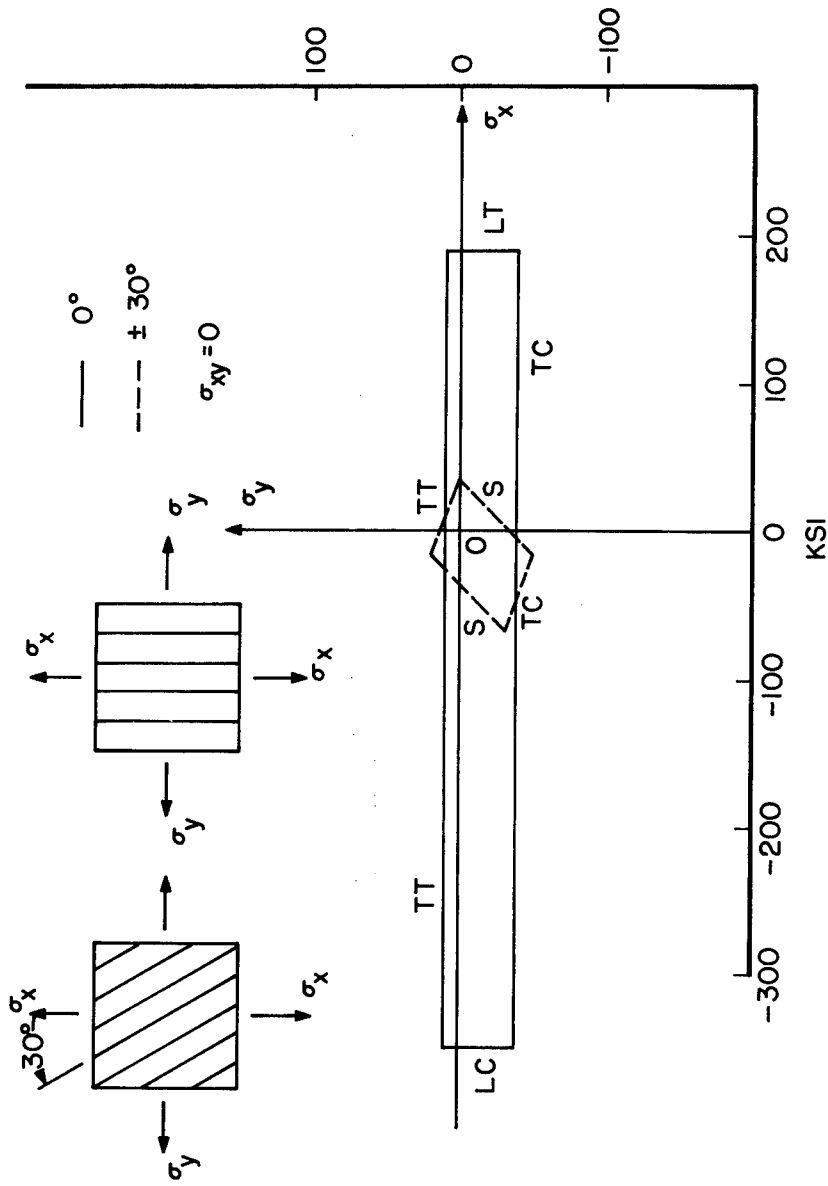

Figure 11. Failure Surfaces of Boron/Epoxy Lamina as Independent Layers

BORON/EPOXY

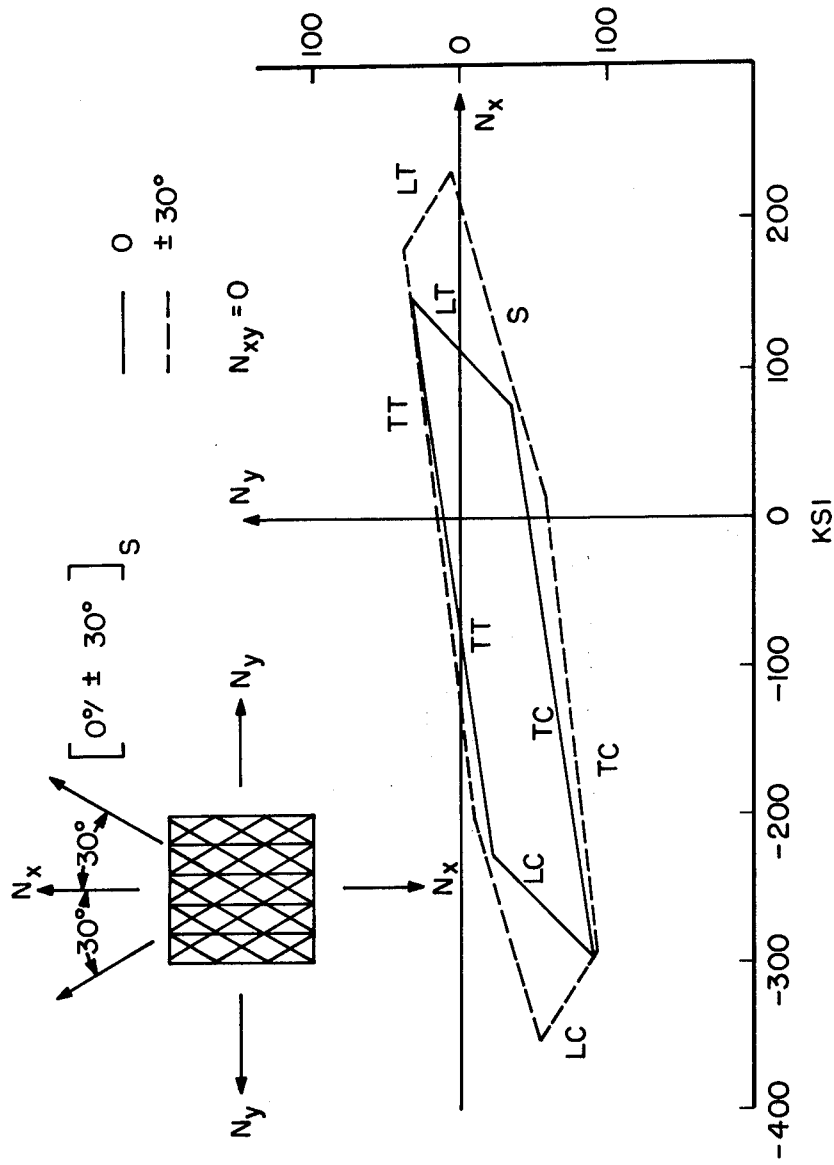

Figure 12. Failure Surfaces of Boron/Epoxy Lamina as Constituent Layers in $[0^\circ/\pm 30^\circ]_s$ Laminates

SECTION IV

COMPARISON BETWEEN STRESS AND
STRAIN FAILURE CRITERIA

In the preceding section limiting strains were obtained from failure stresses under the assumption of linear stress-strain relation. It was noted also that those are not the actual values but fictitious ones because, frequently, the relation is not quite linear. Unidirectional composites are observed to behave nonlinearly, especially in longitudinal shear. Recently, an attempt has been made to describe analytically this shear nonlinearity. A reasonably good agreement was shown between the analytical predictions and experimental data when a term of fourth order in shear stress was added to the plane-stress complementary energy of the linear elasticity.

Physically, failure criteria in stress and in strain should be convertible to each other because they express the same phenomena. What prevents this is the lack of both exact criteria and accurate stress-strain relation.

It is shown in Reference 7 that a stress tensor polynomial of second order provides a reasonably accurate failure criterion. Then the question that might be asked is, how does it compare with a strain tensor polynomial of the same order? An answer to this question will be attempted by taking a stress-strain relation of the form suggested in Reference 4 .

The stress-strain relation we shall use is written as

$$\begin{pmatrix} e_1 \\ e_2 \\ e_6 \end{pmatrix} = [S_{ij}] \begin{pmatrix} \sigma_1 \\ \sigma_2 \\ \sigma_6 \end{pmatrix} + S_{6666} \sigma_6^2 \begin{pmatrix} 0 \\ 0 \\ \sigma_6 \end{pmatrix}, \quad (48)$$

where the linear compliance matrix $[S_{ij}]$ is given by

$$[S_{ij}] = \begin{bmatrix} S_{11} & S_{12} & 0 \\ S_{12} & S_{22} & 0 \\ 0 & 0 & S_{66} \end{bmatrix} \quad (49)$$

Then, substituting Equation (48) into Equation (15) yields

$$\begin{aligned} \bar{f}(\sigma_i) = & \bar{F}_1 \sigma_1 + \bar{F}_2 \sigma_2 + \bar{F}_{11} \sigma_1^2 + 2\bar{F}_{12} \sigma_1 \sigma_2 + \bar{F}_{22} \sigma_2^2 \\ & + \bar{F}_{66} (1 + \alpha \sigma_6^2)^2 \sigma_6^2 = 1 \end{aligned} \quad (50)$$

where \bar{F}_i and \bar{F}_{ij} are defined by

$$\bar{F}_i = S_{ij} G_j, \quad \bar{F}_{ij} = S_{ik} S_{jl} G_{kl}; \quad i = 1, 2 \quad (51)$$

and

$$\alpha = S_{6666} / S_{66} \quad (52)$$

Now that the strain polynomial is converted to a stress polynomial, the stage is set to compare the stress and strain criteria of failure when they both are described by polynomials of second order. For this purpose the stress polynomial given in Appendix I is rewritten as

$$f(\sigma_i) = F_1 \sigma_1 + F_2 \sigma_2 + F_{11} \sigma_1^2 + 2F_{12} \sigma_1 \sigma_2 + F_{22} \sigma_2^2 + F_{66} \sigma_6^2 = 1 \quad (53)$$

Five coefficients except F_{66} are determined from five different tests (guiding experiments (Reference 16) in the $\sigma_1 - \sigma_2$ plane: tension and compression in the longitudinal and transverse directions and a biaxial loading). Therefore, it follows that

$$F_i = \bar{F}_i, \quad F_{ij} = \bar{F}_{ij}; \quad i, j = 1, 2 \quad (54)$$

However, in order for Equations (50) and (53) to have the same intercept $\pm X_6$ along the σ_6 axis, the following relation should hold:

$$\bar{F}_{66} = \frac{1}{(1 + \alpha X_6^2)^2} F_{66} \quad (55)$$

Thus the failure surface in the stress coordinates representing the strain criterion of the form (Equation 15) can be written as

$$\begin{aligned} \bar{f}(\sigma_i) = & F_1 \sigma_1 + F_2 \sigma_2 + F_{11} \sigma_1^2 + 2F_{12} \sigma_1 \sigma_2 + F_{22} \sigma_2^2 \\ & + F_{66} \left(\frac{1 + \alpha \sigma_6^2}{1 + \alpha X_6^2} \right)^2 \sigma_6^2 = 1 \end{aligned} \quad (56)$$

Suppose that $(\sigma_1, \sigma_2, \sigma_6)$ and $(\sigma_1, \sigma_2, \bar{\sigma}_6)$ satisfy Equations (53) and (56), respectively. Then we have

$$\frac{|\sigma_6|}{|\bar{\sigma}_6|} = \frac{1 + \alpha \bar{\sigma}_6^2}{1 + \alpha X_6^2} \quad (57)$$

The above equation implies that

$$|\bar{\sigma}_6| \begin{matrix} \geq \\ \leq \end{matrix} |\sigma_6| \quad \text{as} \quad |\bar{\sigma}_6| \begin{matrix} \leq \\ \geq \end{matrix} X_6 \quad (58)$$

In other words, the strain criterion predicts a higher failure stress of shear in combined loadings when the applied shear stress is less than the failure stress in pure shear, and vice versa.

Figures 13 and 14 show ellipses described by Equations (53) and (56). The data except α are for graphite fiber (Morganite II) reinforced epoxy composite lamina fabricated by Whittaker Corporation:

$$\begin{aligned} F_1 &= -0.003 \text{ (ksi)}^{-1}, & F_2 &= 0.105 \text{ (ksi)}^{-1}, \\ F_6 &= 0, \\ F_{11} &= 0.065 \times 10^{-3} \text{ (ksi)}^{-2}, & F_{22} &= 8.72 \times 10^{-3} \text{ (ksi)}^{-2}, \\ F_{66} &= 9.07 \times 10^{-3} \text{ (ksi)}^{-2}, & F_{12} &= 0.2 \times 10^{-3} \text{ (ksi)}^{-2} \end{aligned}$$

The values of α are taken from Reference 4 only for illustration purposes. However, the actual value for the chosen composite is expected to fall within the range considered. It seems that with higher values of α the strain failure criterion tends toward the maximum stress criterion. At present there is no conclusive experimental evidence which can support the choice of one over the other. In any case, the difference seems rather small.

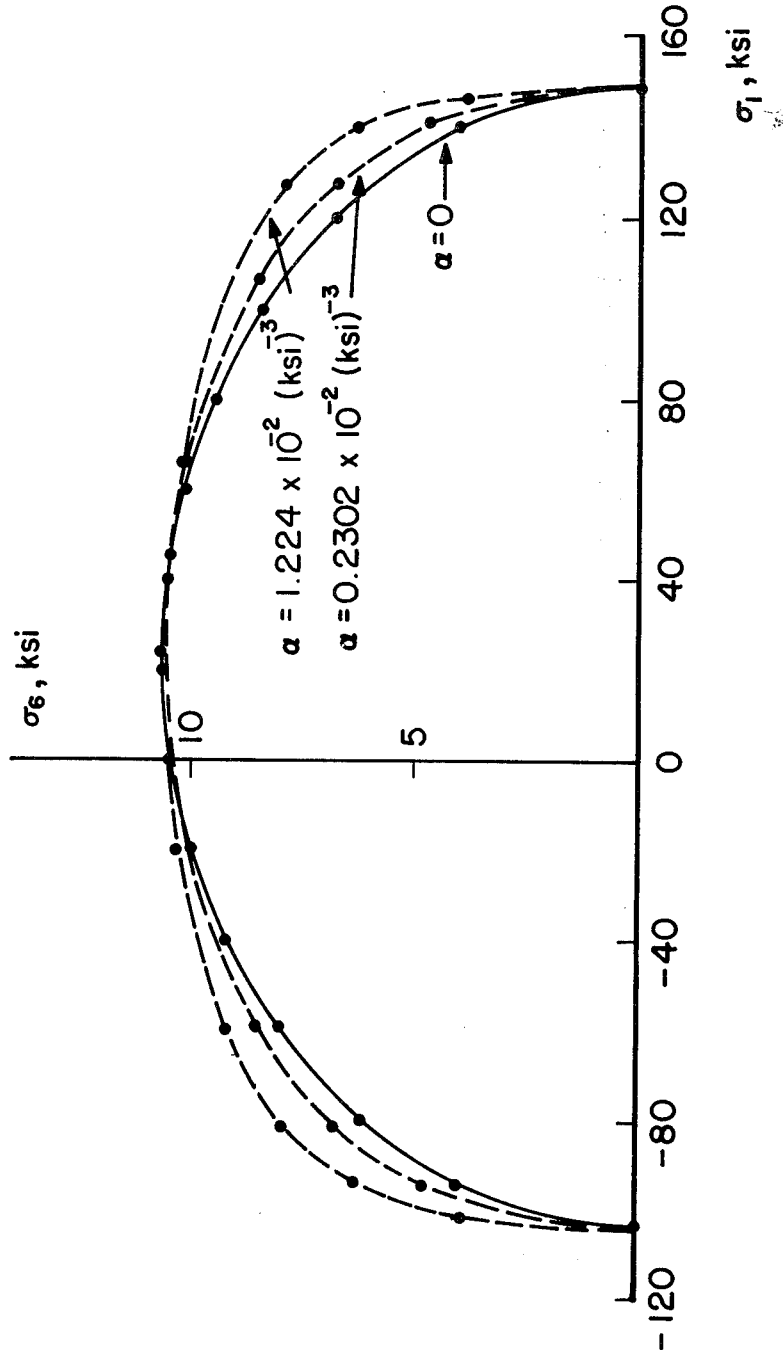

Figure 13. Comparison Between Stress and Strain Criteria; $\sigma_1 - \sigma_6$ Plane

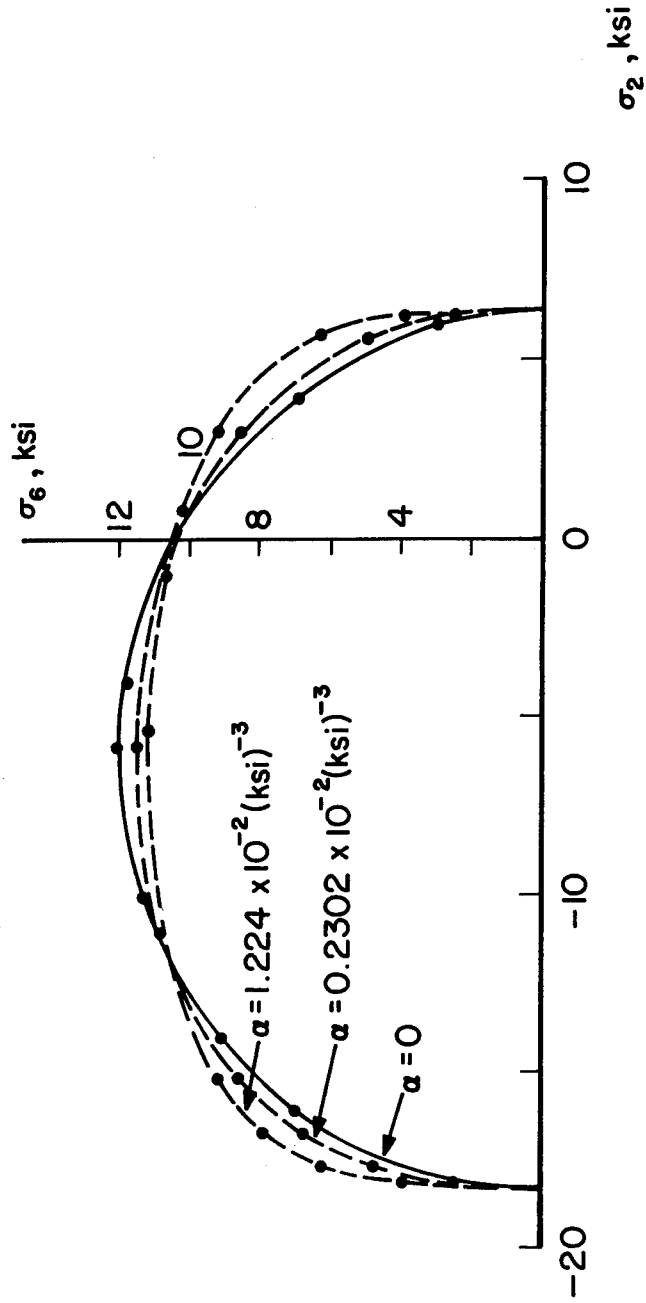

Figure 14. Comparison Between Stress and Strain Criteria, $\sigma_2 - \sigma_6$ Plane

SECTION V

SUMMARY

Current practice of constructing the initial failure surface of laminates is rather complicated and usually needs the help of a computer. Moreover, in the design of laminated composites it is frequently necessary to change the lay-up configuration. Thus, for each case a failure surface must be determined anew.

In the proposed method coupled with the Kirchhoff assumption, the failure surface is constructed only once for a layer with given direction, usually 0° orientation. Failure surfaces for the other off-axis layers are obtained from that for the 0° layer simply through an appropriate rotation about the axis of dilatational strain. Alternately, we may hold the failure surface fixed while rotating the strain coordinates through a pertinent angle.

The method is based on the observation that the transformation matrix for the strain components becomes orthogonal when the shear strain e_6 is replaced by $e_6/\sqrt{2}$. For the stress one has to multiply the shear stress by $\sqrt{2}$. Consequently, it is proposed to use

$$p = \frac{1}{2}(e_1 + e_2), \quad q = \frac{1}{2}(e_1 - e_2), \quad r = \frac{e_6}{2} \quad (59)$$

in place of e_1 , e_2 , e_6 . The above are the quantities we are familiar with in the Mohr's circle representation of a strain state. Then it is easily

verified that there exists a one-to-one correspondence between the rotation of (χ_1, χ_2) and that of (q, r) .

One of the disadvantages may be that uniaxial strengths are not apparent in the proposed method. This can, however, be resolved by studying the relation between p and q , and if failure surfaces are available in the q - r plane for a reasonable number of p values.

Using the constitutive equation suggested in Equation 4 to describe the nonlinearity in shear, a comparison was made between the stress and strain criteria of failure when they both are described by polynomials of second order. Although there is a noticeable difference in combined stress state, no experimental data are available yet to favor one over the other. Considering both the difficulty of working with nonlinear equations and experimental scatter, the difference may be neglected.

REFERENCES

1. H. T. Hahn, "A Derivation of Invariants of Fourth Rank Tensors",
to appear in J. Composite Materials.
2. E. M. Wu, "Phenomenological Anisotropic Failure Criterion",
to be published.
3. G. C. Grimes and J. M. Whitney, "Use of Significant Stress (Strain)
Levels in Composites for Developing Design Allowables", Proc.
the Conference on Fibrous Composites in Flight Vehicle Design ,
Air Force Flight Dynamics Laboratory, AFFDL-TR-72-130, 1972,
p. 1023.
4. H. T. Hahn and S. W. Tsai, "Nonlinear Elastic Behavior of
Unidirectional Composite Laminae", J. Composite Materials, Vol.
7 (1973), p. 102.
5. H. T. Hahn, "Nonlinear Behavior of Laminated Composites",
J. Composite Materials, Vol. 7 (1973), p. 257.
6. Advanced Composites Design Guide, Air Force Materials Laboratory
(AFML/LC), Vol. 1, 1973.
7. S. W. Tsai and E. M. Wu, "A General Theory of Strength for
Anisotropic Materials", J. Composite Materials, Vol. 5 (1971),
p. 58.

REFERENCES (CONTINUED)

8. E. M. Wu, "Strength and Fracture of Composites", to be published.
9. S. W. Tsai, "Strength Characteristics of Composite Materials", NASA CR-224, 1965.
10. P. H. Petit and M. E. Waddoups, "A Method of Predicting the Nonlinear Behavior of Laminated Composites", J. Composite Materials, Vol. 3 (1969), p. 2.
11. J. C. Halpin, "Structure-Property Relations and Reliability Concepts", J. Composite Materials, Vol. 6 (1972), p. 208.
12. R. B. Pipes and N. J. Pagano, "Interlaminar Stresses in Composite Laminates Under Uniform Axial Extension", J. Composite Materials, Vol. 4 (1970), p. 538.
13. N. J. Pagano and R. B. Pipes, "Some Observations on the Interlaminar Strength of Composite Laminates", Int. J. Mech. Sci., Vol. 15 (1973), p. 679.
14. P. C. Chou, B. M. McNameec and D. K. Chou, "The Yield Criterion of Laminated Media", J. Composite Materials, Vol. 7 (1973), p. 22.
15. S. W. Tsai and N. J. Pagano, "Invariant Properties of Composite Materials", in Composite Materials Workshop, Technomic, 1968.

REFERENCES (CONTINUED)

16. E. M. Wu, "Optimal Experimental Measurements of Anisotropic Failure Tensors", J. Composite Materials, Vol. 6 (1972), p. 472.

APPENDIX I

MODIFIED STRENGTH TENSOR COMPONENTS

Strength failure criterion:

$$f(\underline{\sigma}) = F_i \sigma_i + F_{ij} \sigma_i \sigma_j = 1.$$

Modified criterion:

$$f^o(\underline{\sigma}^o) = F_i^o \sigma_i^o + F_{ij}^o \sigma_i^o \sigma_j^o = 1,$$

where

$$\begin{pmatrix} F_1^o \\ F_2^o \\ F_6^o \end{pmatrix} = \begin{pmatrix} F_1 + F_2 \\ F_1 - F_2 \\ F_6 \end{pmatrix},$$

$$[F_{ij}^o] = \begin{bmatrix} F_{11} + 2F_{12} + F_{22} & F_{11} - F_{22} & F_{16} + F_{26} \\ & F_{11} - 2F_{12} + F_{22} & F_{16} - F_{26} \\ \text{symmetric} & & F_{66} \end{bmatrix}.$$

APPENDIX II

USE OF FAILURE SURFACES IN q-r PLANE

Suppose the elastic stress analysis of a laminated composite has yielded the following strain components referred to the laminate reference axes:

$$(e_x, e_y, e_{xy}).$$

Failure surfaces of 0° layer corresponding to various values of p are available in the q - r plane. Failure of each layer under the given state of strain can then be checked by following the procedure described below (Figure 6):

- a. Calculate p , q , r using Equation (4), i.e.,

$$p = (e_x + e_y)/2, \quad q = (e_x - e_y)/2, \quad r = e_{xy}/2$$

- b. Choose the failure surface corresponding to the calculated value of p in the q - r plane.

- c. Find the point Q with coordinates (q, r) and draw a straight line \overline{OQ} connecting the origin O and the point Q .

- d. For a ϕ° layer, find the point Q' such that $\overline{OQ'}$ is obtained by rotating \overline{OQ} clockwise through angle 2ϕ .

- e. If Q' is inside the region enclosed by the chosen failure surface, the layer is safe. Otherwise, the layer has failed.

UNCLASSIFIED

Security Classification

DOCUMENT CONTROL DATA - R & D

(Security classification of title, body of abstract and indexing annotation must be entered when the overall report is classified)

1. ORIGINATING ACTIVITY (Corporate author) Air Force Materials Laboratory Wright-Patterson AFB, Ohio 45433		2a. REPORT SECURITY CLASSIFICATION Unclassified	
		2b. GROUP	
3. REPORT TITLE AN ALTERNATE GRAPHICAL REPRESENTATION OF FAILURE SURFACE			
4. DESCRIPTIVE NOTES (Type of report and inclusive dates) August 1973 - November 1973			
5. AUTHOR(S) (First name, middle initial, last name) H. T. Hahn and Stephen W. Tsai			
6. REPORT DATE May 1974	7a. TOTAL NO. OF PAGES 51	7b. NO. OF REFS 16	
8a. CONTRACT OR GRANT NO.		9a. ORIGINATOR'S REPORT NUMBER(S)	
b. PROJECT NO. 7342			
c. Task No. 734202		9b. OTHER REPORT NO(S) (Any other numbers that may be assigned this report)	
d.			
10. DISTRIBUTION STATEMENT Approved for public release; distribution unlimited.			
11. SUPPLEMENTARY NOTES		12. SPONSORING MILITARY ACTIVITY Air Force Materials Laboratory Wright-Patterson AFB, Ohio 45433	
13. ABSTRACT Failure surface of laminated composites can be constructed in special strain space such that the transformation of strain components becomes an orthogonal matrix. This construction provides a convenient means of studying strength of laminates consisting of arbitrary lamina orientations. This special construction of failure surface can be based on the maximum strain theory, the tensor polynomial theory or other failure criteria of the lamina. The effect of nonlinearity due to shear on the failure surface is also illustrated.			

DD FORM 1 NOV 65 1473

UNCLASSIFIED

Security Classification

UNCLASSIFIED

Security Classification

14. KEY WORDS	LINK A		LINK B		LINK C	
	ROLE	WT	ROLE	WT	ROLE	WT
Composites Failure Surface Maximum Strain Criterion Tensor Polynomial Criterion Nonlinearity						

UNCLASSIFIED

Security Classification