

Development In Business Simulation & Experiential Exercises, Volume 18, 1991

AN APPLICATION OF FINANCIAL ANALYSIS OF THE BUSINESS FIRM IN A SIMULATED COMPETITIVE ENVIRONMENT

Charles K. Woodruff, Winthrop College

ABSTRACT

A procedure is described whereby the Business Management Laboratory business game was modified to produce financial data records that were then imported into the fisCAL financial analysis software package. The record schema contained 101 data fields in an ASCII format with delimiters. Data fields included income statement and balance sheet items as well as such items as the capitalization rate, discount rate, various valuation factors, etc.

Students in a graduate strategic management course were required to subject the imported financial data to the structured financial analysis of fisCAL. Industry comparisons on a normalized basis were made using both percent and dollar variance measures. Such comparisons were made for income statement and balance sheet items, breakeven analysis, operating capital requirements, financial ratios, and cash market value. Based upon multiple previous periods, trends and proforma projections are made for the income statement, balance sheet, financial ratios, and cash flow management.

INTRODUCTION

As the decade of the 1990s begins, the central role of strategic management in business becomes increasingly emphasized. The changing and shifting nature of the world's economies has altered dramatically the membership of the economically developed, developing, and undeveloped nations. Falling barriers between nations, both natural and superimposed have resulted in significant opportunities for those business firms that possess competitive advantages and have positioned themselves to exploit these advantages.

Business schools are being called upon to train their students to be able to manage business firms which will face the new competition that will be considerably different and more intense than that of the past. Students will be called upon to develop their business skills more than ever to acquire personal proficiencies in all of the business functions, not just a selected preferred few.

NEED FOR STRUCTURAL FINANCIAL ANALYSIS

Of all the functional areas of business the financial function permeates the firm more extensively than any other. While this should not be construed to mean that the finance function conclusively is the most important function, it is reasonable to conclude that management of a successful business firm requires a proficiency of financial management by all managers of accountability.

As a teacher of strategic management for graduate MBA students it has become apparent that the need to develop financial proficiency has heightened significantly in recent years. There have been enormous demands placed upon executives due to such things as more intensive competition, shifting nature of the competition itself, and rapid movement toward global economies and away from strictly domestic economies. Just as these demands accelerate in the business world, pressures increase to educate future managers while students in MBA degree programs to learn financial

management sufficiently well to deal with a myriad of problems as yet unencountered.

For educators the task is made more challenging due to the wide diversity of backgrounds of students typically enrolled in MBA programs. Such backgrounds vary from those students who have been exposed previously to financial management only in a limited number of finance and accounting courses as required by the MBA curricula to those students who have majored in finance or accounting as students, some of whom also bring extensive related work experience into the classroom. To develop such a diverse group of students demands innovative approaches to teaching.

The primary objective of the strategic management course is to integrate in a meaningful manner that which the student has learned in prior courses as well as the student's related experiences. This integration process is facilitated when the approach utilized is both systematic and thorough. As the typical student becomes more accustomed to this approach, learning becomes less encumbered by the unfamiliar.

CREATING A DYNAMIC ENVIRONMENT THROUGH SIMULATION

In order to develop financial proficiency, it is imperative that individual capability to analyze financial data be reinforced through experiential exercises utilizing representative data. Providing appropriate financial data to be analyzed can be a difficult assignment for the educator.

One popular source of data for financial analysis has been the business case. The business case often is a description of a firm within which a scenario is presented, usually with accompanying financial data. Such data will expose or verify the firm's strengths and weaknesses when properly analyzed. The firm may be an actual business firm, sometimes identified, sometimes given a fictional name and disguised, or the firm may be totally fictionalized in order to develop specific analysis abilities of the student. Realism is the greatest benefit to be derived from analyses of business cases. Thus, the classroom potentially can become a laboratory of the business world.

On the other hand, the business case often is subjected to a wide array of criticisms, e.g., accuracy, consistency, completeness, degree of complexity, etc. The greatest disadvantage of the case method, given these criticisms, is the student's lack of access to the events and decisions, which preceded and ultimately produced the scenario and the associated data. No place is this more evident than in the firm's financial data. Given the summarization level of historical accounting reporting, e.g., income statements and balance sheets, the student inevitably must mentally reconstruct within the individual's ability what events and decisions most likely would have produced such results.

Simulation provides the means whereby the student can become directly involved in both the events and decisions that produce the data to be analyzed. Business gaming can create an environment that approximates the competitive nature of a selected segment of an industry that may be found in the

Development In Business Simulation & Experiential Exercises, Volume 18, 1991

business world. The student as game participant is required to analyze the data generated by the simulation and then to determine the values of the variables necessary for the subsequent simulation.

The business game selected in this application to simulate a representative competitive environment and generate the associated data for analysis was the Business Management Laboratory (BML) of Jensen and Cherrington (1984). This game simulates the stainless steel flatware and kitchen aids industry. Selection was based first on the capability of the game to integrate all the functional business areas and, second, on the capability to generate data for structured financial analyses. In addition, BML allows the student firms or teams to create varying competitive environments within the pre-stated parameters, which is essential in a strategic management course. One consequence is that individual firms may pursue cost leadership strategies or product differentiation strategies and still be successful in their financial performance even in a heterogeneous competitive environment.

DEVELOPING AND IMPLEMENTING AN INTERFACE WITH FINANCIAL ANALYSIS SOFTWARE

Attention focused next on selection of a microcomputer software package capable of facilitating structured financial analysis. The selected package would have to be sufficiently accurate and reliable that it would be credible to the student. In addition, the cost of the package would have to be within the budgetary constraints of both the student and the institution.

The financial analysis software package selected was fisCAL, a product of the Halcyon Group (1990). An earlier version of this software had been used under a license agreement in a limited number of courses. One of the restrictions of the earlier version was the requirement that all financial data be keyed as input. Version 4.30, released in the fall of 1990, provides the capability to import previously created data records in fixed length ASCII format, variable length ASCII format, or dBASE III format. This version also requires the student to purchase, at a nominal charge, a user documentation manual, which contains a key disk for the authorized user.

Since BML is made available in BASIC source code, it was decided to add a new subroutine to the chained subroutines in order to generate the financial data records for each firm. The variable length ASCII record format was chosen. This record schema contains 101 data fields which include income statement and balance sheet items as well as such data as the capitalization rate, discount rate, various valuation factors, etc.

The financial data records for each student firm is distributed to that student firm on a floppy disk also used for the BML input decision data. In order for the students to import the fisCAL data, each student must use the key disk from their manual to gain access to the fisCAL software on the institution's microcomputer network. The key disk utilizes a coded overlay feature, much like a key opens a door lock, in order to identify authorized users.

All of the data records to be analyzed in fisCAL must be placed on the key disk in a single data file with an associated index (or locator) file. Next, all of the imported data records must be passed through the edit feature in order to compute several data totals such as net profits, total assets, liabilities and net worth.

DESCRIPTION OF THE FINANCIAL ANALYSIS SOFTWARE PACKAGE

Single Period Reports

Industry standards data may be accessed through the use of the Standard Industrial Classification code (SIC code), in this case for the cutlery industry. While these standards are not the actual standards for the competitive environment created in BML by the students, the similarities are quite high. Income statement and balance sheet items may be compared to the industry standard on a normalized basis, e.g., prorated industry standard firm with equal total assets. Comparisons with the industry standard are produced on a percent variance basis and on a dollar variance basis.

Among the other comparisons available are breakeven analysis, operating capital requirements, financial ratios, and cash market value analysis.

Trends Analysis and Reports

Based upon the three most recent time periods, trends are computed and compared to the industry standards for income statement and balance sheet items and for various financial ratios. Cash flow analysis and operating ratios analysis are also available.

Strategic Analysis Module Reports

The emphasis of this module is the computation and presentation of the DuPont model for profitability and investment return analysis. This approach also is extended further to the return on inventory investment model.

Proforma Projections Analysis Reports

Using the most current time period data in conjunction with the five previous time periods, projections can be made to five time periods into the future. These proforma projections are made for income statement and balance sheet items and for several selected financial ratios.

STUDENT ANALYSES

Student firms are required to evaluate each of the reports in the four groups above. Industry standards comparisons have been especially beneficial. Although the fisCAL industry standards are for the actual cutlery industry and not the competitive industry created by the simulation, comparisons of the numerous items to the actual cutlery industry standards has revealed the majority of deficiencies and problems confronting the typical student firm. One example is the level of inventories carried to support the sales revenues generated. The need for proper balancing of inventory levels to both the firm's marketing plan and production plan has become quite apparent to the students.

Cash flow management also has improved as a consequence of these analyses. The timing of the cash inflow to the generation of sales and the cash disbursement to the incurring of expenses is a perplexing difficulty for most MBA students. By reviewing cash flow systematically in terms of flow from operations, investing activities, and financing activities, students gain a much better grasp of the location of the cash flow difficulty when it arises.

Students experience their greatest difficulties as they analyze the proforma projection analysis reports.

Development In Business Simulation & Experiential Exercises, Volume 18, 1991

Figure 1

Business Game – Financial Analysis Software interface

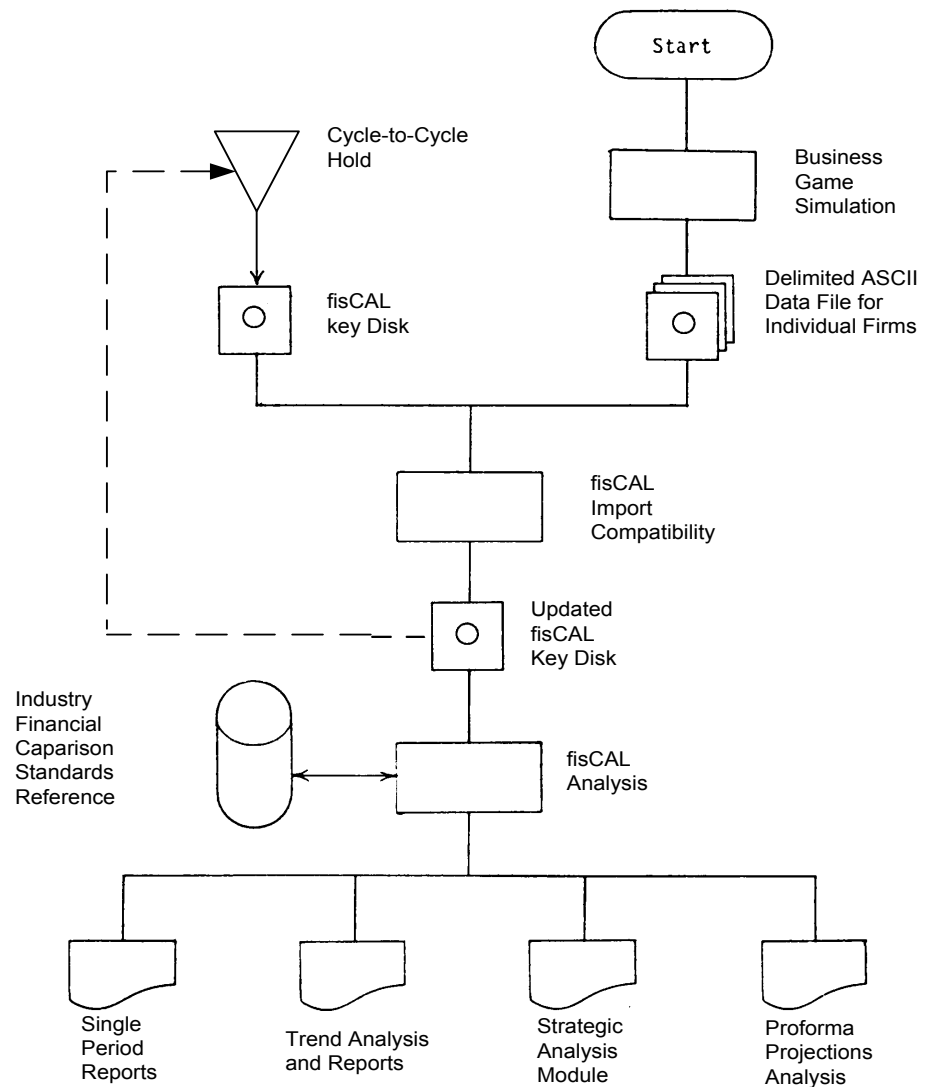

One explanation perhaps is the large quantity of quantitative financial data contained in the reports. A disciplined approach acquired as a consequence of experience may be a prerequisite for thorough analysis.

CONCLUSIONS

Reactions of students to date has been generally favorable. Initially, many students felt uneasy when confronted by the voluminous financial data; this is a classic example of information overload. For the student acclimated toward using all data provided by the teacher, information overload can be a frustrating experience. Nevertheless, it is a meaningful experience since it is more reflective of the business world than is the former.

The greatest potential benefit for the MBA student is that these financial reports do not provide answers as such. Rather, the reports furnish the means by which one may gain insight into financial constructs so common to the business firm. Simulation with student input decisions provides the mechanism to bring together decision making and data analysis as a hands on and lasting learning experience.

REFERENCES

- Halcyon Group (1990). Profiting from financial statements. Charleston, SC: Halcyon Group.
- Jensen, R.L., & Cherrington, D.J. (1984). Participant's manual: the business management laboratory. Plano, TX: Business Publications, Inc.