

An Approach Transient Stability Analysis Using Equivalent Impedance Modified in 150 kV South of Sulawesi System

Muhammad Ruswandi Djalal¹
Herman Nawir²

^{1,2}Department of Mechanical Engineering
State Polytechnic of Ujung Pandang
Makassar, Indonesia

Email : [1wandi@poliupg.ac.id](mailto:wandi@poliupg.ac.id),
[2herman.nawir@poliupg.ac.id](mailto:herman.nawir@poliupg.ac.id)

Herlambang Setiadi³
Andi Imran⁴

³School of Information Technology & Electrical
Engineering The University of Queensland
Brisbane, Australia

⁴Department of Electrical Engineering
Sepuluh Nopember Institute of Technology
Surabaya, Indonesia

Email : [3h.setiadi@uq.edu.au](mailto:h.setiadi@uq.edu.au),
[4andi.imran13@mhs.ee.its.ac.id](mailto:andi.imran13@mhs.ee.its.ac.id)

Abstract— One of methods that can be used to determine the stability of a power system if the fault occurred is the equal area criterion method. The equal area criterion method (Equal Area Criterion, EAC) is an example of a direct method for predicting the stability and also the critical clearing time (Critical clearing time). However, to calculate the complex calculations required to determine the equivalent impedance of each condition system. In this study used several approaches to facilitate the calculation of the equivalent impedance. This method uses the equation of power losses. This method is equivalent impedance using modified with Ploss and Qloss for Determining Pmax. From the analysis, it can be concluded the use of this method is quite accurate in analyzing or calculating the transient stability of the generator system in South Sulawesi, with each loading condition, before, during and after short circuit. Generator being looked at is Bakaru, Pare, Suppa, Barru and Sengkang.

Keywords— Equal Area Criterion (EAC), Equivalent Impedance, Transient Stability, Critical Clearing Time

I. INTRODUCTION

In the electric power system operation, the system conditions change suddenly, usually occurs due to a disturbance such as a short circuit in the power system, but it also caused the release or the addition of load suddenly [1]. Due to changes in operating conditions of the system, then the system state will change from the old condition to a new condition. Short period between the condition is called a transition period or also called transient. Therefore we need a power system analysis to determine whether the system is stable or not, if there is fault on the system. Many methods are used to analyze the stability of the power

system [2], here will be discussed one of the methods that can be used to determine the stability of a power system if the fault occurred is using the equal area criterion. This method is not used in the system multimesin, so that the multimachine system is converted to single machine or often called a Single Machine Infinite Bus (SMIB). The equal area criterion method (Equal Area Criterion, EAC) is an example of a direct method for predicting the stability and also the critical clearing time (Critical clearing time).

In several research have used this method for determining transient stability of generator, those are using equal area criterion directly used to a non-equivalent generator pair [3], [4] using A simple direct method, [5] using Extended equal area criterion justifications, [6] using EAC with on-line transient stability analysis, [7] using a novel dynamic equivalent reduction technique, [8] using based upon the extended equal area criterion, [9] using PC based software package for the equal area criterion, [10] using based hybrid extended equal area criterion method, [11] using critical clearing time sensitivity, [12] using A new implemented pole slipping protection algorithm using the equal area criterion, [13] using employing Equal Area Criterion, [14] using An Improved Iterative Method for Assessment of Multi-Swing Transient Stability Limit, [15] using Effective and robust case screening for transient stability assessment. Previous research may have a long and complicated calculations in determining the equivalent reactance of each loading condition. In this study, we discuss how to facilitate calculate the impedance is equivalent to using the power loss equation. the results obtained are quite accurate in calculating the stability with the equal area criterion and critical clearing time.

II. TRANSIENT STABILITY

The stability of a power system is the ability of power system consists of several Transient ability of a power system to maintain synchronization after a large disturbance that is suddenly for about one "swing" (the first) with the assumption that the automatic voltage regulator (AVR) and the governor has not worked .

II.1. Basic Power Curve in SMIB

Given a SMIB of a system in Figure 1

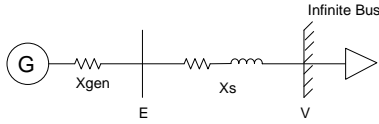

Figure 1. SMIB Model

$$E = V + jX_s I \tag{1}$$

$$\frac{E}{\sin(90 + \phi)} = \frac{X_s I}{\sin \delta}$$

$$I \cos \phi = \frac{E}{X_s} \sin \delta \tag{2}$$

Where,

- E = Terminal Voltage at Generator (Volt)
- V = Infinite Bus Voltage (Volt)
- Xs = Equivalent Reactance of System (Ohm)
- I = Generator Current (Load Current) (A)

So that the power supplied to the load is

$$P = V.I \cos \phi \tag{3}$$

$$P = \frac{V.E}{X_s} \tag{4}$$

Xs is the sum of the equivalent reactance of the overall system with generator reactance.

II.2. Equal-Area Criterion

The stability of a generator due to disturbance in the power system can be analyzed by using various methods. The method is very popular is the same broad criteria method. In figure 2, it is assumed Pm is constant and steady state, the generator supplying power to the system with power angle δ0. When a disturbance occurs no power is delivered to the infinite bus.

$$\frac{H}{\pi f_0} \frac{d^2 \delta}{dt^2} = P_m - P_e = P_a \tag{5}$$

Where,

- H = Inertia Constant (Wk/Sb²)
- δ = Electrical Degress
- f0 = Frequency (Hz)
- Pm = Mechanical Power (W)
- Pe = Electrical Power (W)

From equation obtained stability criteria

$$\int_{\delta_0}^{\delta} (P_m - P_e) d\delta = 0 \tag{6}$$

Energy stored in the rotor during initial acceleration,

$$\int_{\delta_0}^{\delta_1} (P_m - P_e) d\delta = \text{area } abc = \text{area } A_1 \tag{7}$$

$$|\text{area } A_1| = |\text{area } A_2| \tag{8}$$

Application to Three-Phase Fault

Application equal area criterion method can be used to determine critical clearing angle. To determine critical clearing angle swing requires a nonlinear equation. In these conditions, Pe during disturbance is 0.

$$t_c = \sqrt{\frac{2H(\delta_c - \delta_0)}{\pi f_0 P_m}} \tag{9}$$

Here are examples of three-phase fault in a two-line SMIB system,

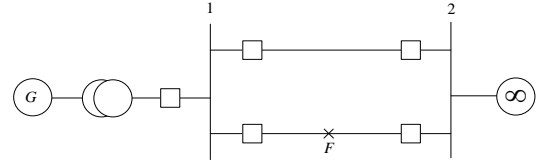

Figure 2. One-machine system connected to infinite bus, F is three-phase fault

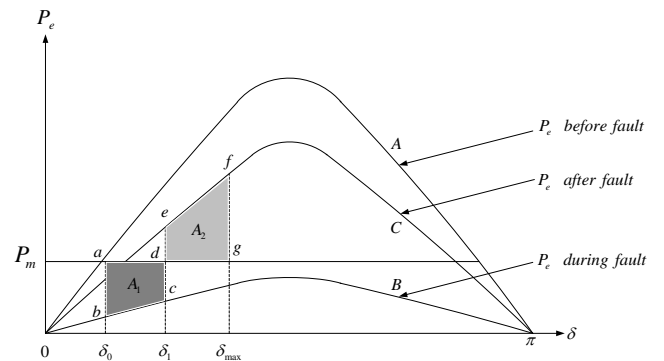

Figure 3. EAC for three-phase fault at the way from the sending end

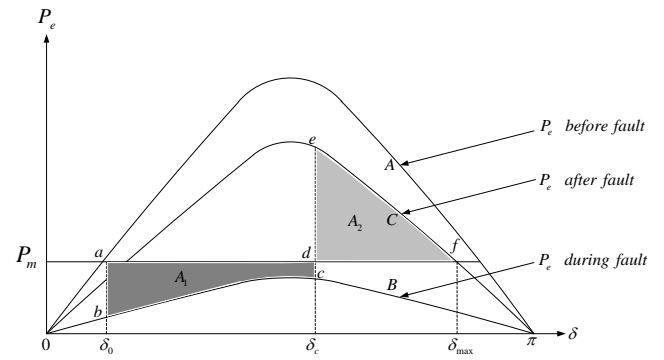

Figure 4. EAC for critical clearing angle

From the picture above is obtained,

$$\cos \delta_c = \frac{P_m (\delta_{max} - \delta_0) + P_{3max} \cos \delta_{max} - P_{2max} \cos \delta_0}{P_{3max} - P_{2max}} \tag{10}$$

Where, P3max and P2max represents generator power at during fault and after fault.

III. THE PROPOSED METHOD WITH EQUIVALENT IMPEDANCE MODIFIED

From the explanations that have been described, here will be explained the method to be used. From equation 1 is obtained,

$$E = V + jZ.I$$

$$E = V + j(R + jX).I \tag{10}$$

$$P_{\max} = \frac{V \cdot E}{X_s} \quad (12)$$

Equivalent impedance is calculated by using the formula of active power loss P and reactive power losses Q.

$$P_{\text{loss}} = I^2 R \quad (13)$$

$$R_{\text{equivalent}} = \frac{P_{\text{loss}}}{I^2} \quad (14)$$

$$Q_{\text{loss}} = I^2 X \quad (15)$$

$$X_{\text{equivalent}} = \frac{Q_{\text{loss}}}{I^2} \quad (16)$$

So we get the equivalent impedance equation to be used each loading condition, before, during and after a short circuit.

$$Z_{\text{equivalent}} = R_{\text{equivalent}} + jX_{\text{equivalent}} \quad (17)$$

Power losses obtained from the load flow each loading condition. For a short circuit condition, power loss resulting very large. After knowing the equivalent impedance of each condition, we then calculate the generator terminal voltage and maximum power that can be supplied generator.

IV. CHANGE MULTIMACHINE SYSTEM TO SMIB

Electric power system is a large system with multiple generators (multimachine). If the generator transient stability analysis should be carried out in the multimachine system would be very difficult. Therefore, the system must be changed from multimachine system to SMIB for the first step. Multimachine System converted to SMIB with the aim of making the equivalent impedance and the load equivalent.

V. RESULT AND ANALYSIS

Case studies that used is short circuit on bus 29 Maros and generators that in view of stability is Bakaru hydropower generator, diesel Pare, diesel Suppa, plant and PLTGU Barru Sengkang. This generator is a generator that has a large capacity in the electrical system of South Sulawesi. The following single line diagram of the 150 kV system in

South Sulawesi, which consists of a total of 37 buses. The first step taken to analyze is to change the system multimesin to a single machine infinite bus (SMIB). For the first case using the generator as a generator Bakaru analyzed.

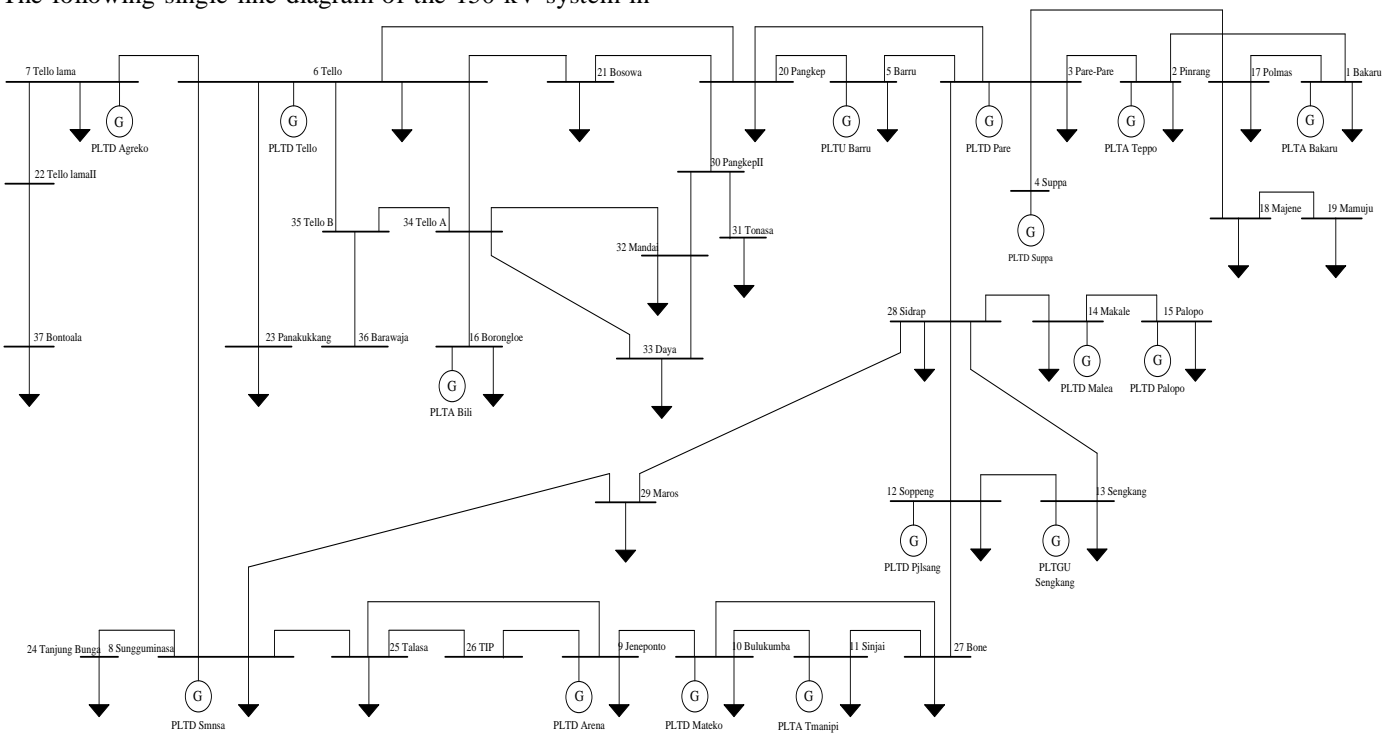

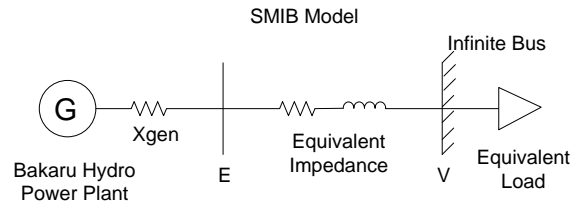

Figure 5. Change Multimachine South Sulawesi System to Single Machine Infinite Bus (SMIB) with Case study short circuit at Bus 29 Maros and bakaru hydro plant as the generator will be studied [16,17]

The first step is running load flow at normal condition with all of generators in service, then we can get multiple factor for decreased the load. The decreasing load for output power from generator is same with normal condition when generator supplies to the load. The following calculated at bakaru hydro plant.

$$\text{multiplier factor (Q)} = \frac{-20.618}{144.000} = -0.1431$$

Having done several approaches, we then can be simulated for short circuit conditions before, during and after a short circuit or a short circuit CB open.

Table 1. Load Flow Result of Normal Condition (all of generators in services)

Bus No	Voltage Mag.	Angle Degree	Load		Generation	
			MW	Mvar	MW	Mvar
1	1.000	0.000	4.400	0.200	116.606	-20.618
2	1.000	-3.869	15.600	-5.600	0.300	-0.463
3	1.000	-5.124	6.000	-0.500	20.100	25.809
4	1.000	-4.041	0.000	0.000	62.200	-16.746
5	1.000	-9.839	6.800	1.700	44.700	24.437
6	1.000	-20.793	39.600	15.300	29.700	106.400
7	1.000	-21.192	14.000	0.400	19.300	8.007
8	1.000	-20.221	9.400	2.500	12.300	36.853
9	1.000	-16.359	10.800	3.100	19.600	7.725
10	1.000	-13.152	11.000	1.600	9.000	3.530
11	1.000	-11.792	13.000	4.400	3.500	13.016
12	1.000	-2.500	3.400	9.100	15.100	14.330
13	1.000	2.915	18.100	7.200	192.900	-5.846
14	1.000	-11.380	9.800	1.800	3.500	3.243
15	1.000	-13.389	29.900	5.900	6.900	12.460
16	1.000	-20.966	7.200	0.000	7.100	6.591
17	0.992	-3.072	10.200	2.900	0.000	0.000
18	0.974	-5.217	9.400	2.200	0.000	0.000
19	0.965	-6.386	10.600	2.000	0.000	0.000
20	0.979	-16.450	15.000	5.800	0.000	0.000
21	0.983	-18.428	20.200	10.000	0.000	0.000
22	0.987	-21.176	0.000	0.000	0.000	0.000
23	0.960	-23.033	56.400	17.000	0.000	0.000
24	0.993	-20.956	31.800	11.300	0.000	0.000
25	0.994	-19.485	20.200	5.800	0.000	0.000
26	0.994	-18.453	0.000	0.000	0.000	0.000
27	0.990	-8.949	21.500	6.100	0.000	0.000
28	0.992	-4.600	18.600	7.100	0.000	0.000
29	0.992	-17.723	8.900	2.200	0.000	0.000
30	0.960	-16.091	0.000	0.000	0.000	0.000
31	0.933	-17.110	37.800	20.800	0.000	0.000
32	0.980	-21.261	22.500	2.100	0.000	0.000
33	0.984	-21.251	20.800	1.600	0.000	0.000
34	0.993	-20.728	0.000	0.000	0.000	0.000
35	0.996	-20.760	0.000	0.000	0.000	0.000
36	0.996	-20.760	0.000	0.000	0.000	0.000
37	0.975	-22.476	29.400	0.000	0.000	0.000
Total			532.300	144.000	562.806	218.727

Before Short Circuit Condition in Bakaru Hydro Power Plant (Others Generator out off Service except Bakaru)

After lowering the load to get a multiplier, then start counting conditions first before short circuit or abnormal conditions. Here are the results of power flow simulation normal conditions with all the generators off, except Bakaru generator.

Table 2. Load Flow Result before short circuit (all generators off except Bakaru Hydro Power Plant)

Bus No	Voltage Mag.	Angle Degree	Load		Generation	
			MW	Mvar	MW	Mvar
1	1.000	0.000	0.964	-0.029	123.134	-39.007
2	1.000	-3.869	3.416	0.801	0.000	0.000
3	1.000	-5.124	1.314	0.072	0.000	0.000
4	1.000	-4.041	0.000	-0.000	0.000	0.000
5	1.000	-9.839	1.489	-0.243	0.000	0.000
6	1.000	-20.793	8.672	-2.189	0.000	0.000
7	1.000	-21.192	3.066	-0.057	0.000	0.000
8	1.000	-20.221	2.059	-0.358	0.000	0.000
9	1.000	-16.359	2.365	-0.444	0.000	0.000
10	1.000	-13.152	2.409	-0.229	0.000	0.000
11	1.000	-11.792	2.847	-0.630	0.000	0.000
12	1.000	-2.500	0.745	-1.302	0.000	0.000
13	1.000	2.915	3.964	-1.030	0.000	0.000
14	1.000	-11.380	2.146	-0.258	0.000	0.000
15	1.000	-13.389	6.548	-0.844	0.000	0.000
16	1.000	-20.966	1.577	-0.000	0.000	0.000
17	0.992	-3.072	2.234	-0.415	0.000	0.000
18	0.974	-5.217	2.059	-0.315	0.000	0.000
19	0.965	-6.386	2.321	-0.286	0.000	0.000
20	0.979	-16.450	3.285	-0.830	0.000	0.000
21	0.983	-18.428	4.424	-1.431	0.000	0.000
22	0.987	-21.176	0.000	-0.000	0.000	0.000
23	0.960	-23.033	12.352	-2.433	0.000	0.000
24	0.993	-20.956	6.964	-1.617	0.000	0.000
25	0.994	-19.485	4.424	-0.830	0.000	0.000
26	0.994	-18.453	0.000	-0.000	0.000	0.000
27	0.990	-8.949	4.708	-0.873	0.000	0.000
28	0.992	-4.600	4.073	-1.016	0.000	0.000
29	0.992	-17.723	1.949	-0.315	0.000	0.000
30	0.960	-16.091	0.000	-0.000	0.000	0.000
31	0.933	-17.110	8.278	-2.976	0.000	0.000
32	0.980	-21.261	4.928	-0.301	0.000	0.000
33	0.984	-21.251	4.555	-0.229	0.000	0.000
34	0.993	-20.728	0.000	-0.000	0.000	0.000
35	0.996	-20.760	0.000	-0.000	0.000	0.000
36	0.996	-20.760	0.000	-0.000	0.000	0.000
37	0.975	-22.476	6.439	-0.000	0.000	0.000
Total			116.574	20.606	123.134	-39.007

From the results obtained load flow profile Bakaru hydro generation plant and the total load of the system. This data will then be used as a multiplier to reduce the load factor. Load lowered so that the generator power equal to the normal condition when the generator supply to the system.

$$\text{multiplier factor (P)} = \frac{116.606}{562.300} = 0.2073$$

Line Flow and Losses for this condition,

MW	Mvar
6.653	-18.011

From the simulation results obtained total load and line losses.

$$\text{Load} = 116.574 - j20.606 \text{ MVA}$$

$$\text{Losses} = 6.653 - j18.011 \text{ MVA}$$

With MVA base 100 MVA, then :

$$P_{load(pu)} = \frac{(116.574 - j20.606)}{100} = 1.16574 - j0.20606pu$$

$$I^* = \frac{S}{V} = \frac{(1.16574 - j0.20606)}{1.0} = 1.1838 \angle 10.0242 pu$$

$$= 1.16574 + j0.20606pu$$

Finding equivalent reactance :

$$P_{losses(pu)} = \frac{(6.653 - j18.011)}{100} = 0.06653 - j0.18011pu$$

$$R_{eki} = \frac{P_{loss}}{I^2} = \frac{0.06653}{1.1838^2} = 0.047473599896133 pu$$

$$X_{eki} = \frac{Q_{loss}}{I^2} = \frac{0.18011}{1.1838^2} = -0.128520518221742 pu$$

$$X_{eki} = 0.38 \left(\frac{100}{126} \right) = 0.301587301587302 pu$$

$$X_{total} = 0.301587301587302 - 0.128520518221742 = 0.173067 pu$$

$$E = V + (R + jXt)I$$

$$= 1 \angle 0 + ((0.047473599896133 + j0.173067(1.16574 + 0.20606i))$$

$$= 1.01967973296261 + 0.211533282035165i = 1.04139 \angle 11.71 pu$$

$$P_{max} = \frac{|E| \cdot |V|}{X_{total}} = \frac{1.04139 \cdot 1}{0.173067} = 6.017272 pu$$

During Short Circuit Condition (all generators off except Bakaru Hydro Power Plant)

By using the same steps as above, a short-circuit on the bus 29 Maros, so the bus short circuit impedance will be lost and the associated line is added to the diagonal matrix corresponding bus. Here are the results of load flow when a short circuit.

Table 3. Load Flow Result during short circuit (all generators off except Bakaru Hydro Power Plant)

Bus No	Voltage Mag.	Angle Degree	Load		Generation	
			MW	Mvar	MW	Mvar
1	1.000	0.000	0.964	-0.029	170.731	255.447
2	0.805	-4.316	3.416	0.801	0.000	0.000
3	0.719	-6.851	1.314	0.072	0.000	0.000
4	0.719	-6.851	0.000	0.000	0.000	0.000
5	0.652	-11.131	1.489	-0.243	0.000	0.000
6	0.520	-21.133	8.672	-2.189	0.000	0.000
7	0.518	-21.665	3.066	-0.057	0.000	0.000
8	0.496	-21.439	2.059	-0.358	0.000	0.000
9	0.521	-21.151	2.365	-0.444	0.000	0.000
10	0.543	-19.628	2.409	-0.229	0.000	0.000
11	0.552	-18.760	2.847	-0.630	0.000	0.000
12	0.585	-12.463	0.745	-1.302	0.000	0.000
13	0.591	-11.139	3.964	-1.030	0.000	0.000
14	0.594	-14.487	2.146	-0.258	0.000	0.000
15	0.591	-16.051	6.548	-0.844	0.000	0.000

16	0.516	-21.607	1.577	0.000	0.000	0.000
17	0.883	-2.645	2.234	-0.415	0.000	0.000
18	0.883	-3.311	2.059	-0.315	0.000	0.000
19	0.883	-3.655	2.321	-0.286	0.000	0.000
20	0.585	-16.391	3.285	-0.830	0.000	0.000
21	0.559	-18.338	4.424	-1.431	0.000	0.000
22	0.513	-21.655	0.000	0.000	0.000	0.000
23	0.513	-23.473	12.352	-2.433	0.000	0.000
24	0.496	-22.156	6.964	-1.617	0.000	0.000
25	0.504	-21.758	4.424	-0.830	0.000	0.000
26	0.509	-21.504	0.000	0.000	0.000	0.000
27	0.564	-16.813	4.708	-0.873	0.000	0.000
28	0.596	-8.976	4.073	-1.016	0.000	0.000
29	0.576	-16.429	0.000	-0.000	0.000	0.000
30	0.574	-17.461	8.278	-2.976	0.000	0.000
31	0.518	-21.575	4.928	-0.301	0.000	0.000
32	0.517	-21.632	4.555	-0.229	0.000	0.000
33	0.517	-21.228	0.000	0.000	0.000	0.000
34	0.519	-21.181	0.000	0.000	0.000	0.000
35	0.519	-21.181	0.000	0.000	0.000	0.000
36	0.508	-22.706	6.439	0.000	0.000	0.000
Total			121.063	-20.292	170.731	255.447

Line Flow and Losses for this condition,

MW	Mvar
42.353	134.718

From the simulation results obtained total load and line losses.

$$\text{Load} = 121.063 - j20.292 \text{ MVA}$$

$$\text{Losses} = 42.353 + j134.718 \text{ MVA}$$

MVA base 100 MVA, then :

$$P_{load(pu)} = \frac{(121.063 - j20.292)}{100} = 1.21063 - j0.20292 pu$$

$$I^* = \frac{S}{V} = \frac{(1.21063 - j0.20292)}{1.0} = 1.227518 \angle 9.515193 pu$$

$$= 1.21063 + j0.20292 pu$$

Finding equivalent reactance,

$$P_{losses(pu)} = \frac{(42.353 + j134.718)}{100} = 0.42353 + j1.34718 pu$$

$$R_{eki} = \frac{P_{loss}}{I^2} = \frac{0.42353}{1.227518^2} = 0.281078823886798 pu$$

$$X_{eki} = \frac{Q_{loss}}{I^2} = \frac{1.34718}{1.227518^2} = 0.894065992878466 pu$$

$$X_{eki} = 0.38 \left(\frac{100}{126} \right) = 0.301587 pu$$

$$X_{total} = 0.894065992878466 + 0.301587 = 1.195653 pu$$

During After Short Circuit Condition (all generators off except Bakaru Hydro Power Plant)

By using the same steps as above, for after a short circuit condition on bus 29 Maros, the CB on both ends of the channel will be open and bus short circuit will be lost so that the line impedance is disconnected and not connected. Here are the results of load flow after a short circuit.

Table 4. Load Flow Result after short circuit (all generators off except Bakuru Hydro Power Plant)

Bus No	Voltage		Load		Generation	
	Mag.	Angle Degree	MW	Mvar	MW	Mvar
1	1.000	0.000	0.964	-0.029	121.312	-33.728
2	1.001	-4.634	3.416	0.801	0.000	0.000
3	1.003	-6.612	1.314	0.072	0.000	0.000
4	1.003	-6.613	0.000	-0.000	0.000	0.000
5	1.004	-9.003	1.489	-0.243	0.000	0.000
6	1.003	-13.261	8.672	-2.189	0.000	0.000
7	1.003	-13.403	3.066	-0.057	0.000	0.000
8	1.005	-13.408	2.059	-0.358	0.000	0.000
9	1.012	-13.111	2.365	-0.444	0.000	0.000
10	1.017	-12.469	2.409	-0.229	0.000	0.000
11	1.019	-12.109	2.847	-0.630	0.000	0.000
12	1.014	-9.626	0.745	-1.302	0.000	0.000
13	1.012	-9.076	3.964	-1.030	0.000	0.000
14	1.012	-10.166	2.146	-0.258	0.000	0.000
15	1.011	-10.707	6.548	-0.844	0.000	0.000
16	1.001	-13.347	1.577	-0.000	0.000	0.000
17	1.002	-3.019	2.234	-0.415	0.000	0.000
18	1.002	-3.544	2.059	-0.315	0.000	0.000
19	1.002	-3.814	2.321	-0.286	0.000	0.000
20	1.004	-11.392	3.285	-0.830	0.000	0.000
21	1.004	-12.196	4.424	-1.431	0.000	0.000
22	1.000	-13.402	0.000	-0.000	0.000	0.000
23	1.000	-13.883	12.352	-2.433	0.000	0.000
24	1.005	-13.584	6.964	-1.617	0.000	0.000
25	1.007	-13.425	4.424	-0.830	0.000	0.000
26	1.009	-13.316	0.000	-0.000	0.000	0.000
27	1.018	-11.349	4.708	-0.873	0.000	0.000
28	1.008	-8.219	4.073	-1.016	0.000	0.000
29	1.000	-11.504	0.000	-0.000	0.000	0.000
30	0.999	-11.846	8.278	-2.976	0.000	0.000
31	1.000	-13.317	4.928	-0.301	0.000	0.000
32	1.000	-13.345	4.555	-0.229	0.000	0.000
33	1.002	-13.245	0.000	-0.000	0.000	0.000
34	1.002	-13.253	0.000	-0.000	0.000	0.000
35	1.002	-13.253	0.000	-0.000	0.000	0.000
36	0.997	-13.677	6.439	-0.000	0.000	0.000
Total			121.063	-20.292	121.312	-33.728

Line Flow and Losses for this condition,

MW	Mvar
6.792	-13.032

From the simulation results obtained total load and line losses.

$$\text{Load} = 121.063 - j20.292 \text{ MVA}$$

$$\text{Losses} = 6.792 - j13.032 \text{ MVA}$$

MVA base 100 MVA, then :

$$P_{load(pu)} = \frac{(121.063 - j20.292)}{100} = 1.21063 - j0.20292 pu$$

$$I^* = \frac{S}{V} = \frac{(1.21063 - j0.20292)}{1.0} = 1.227518 \angle 9.515193 pu$$

$$= 1.21063 + j0.20292 pu$$

Finding equivalent reactance,

$$P_{losses(pu)} = \frac{(6.792 - j13.032)}{100} = 0.06792 - j0.13032 pu$$

$$R_{eki} = \frac{P_{loss}}{I^2} = \frac{0.06792}{1.227518^2} = 0.045075611452297 pu$$

$$X_{eki} = \frac{Q_{loss}}{I^2} = \frac{0.13032}{1.227518^2} = -0.0864878339879762 pu$$

$$X_{eki} = 0.38 \left(\frac{100}{126} \right) = 0.301587301587302i pu$$

$$X_{total} = 0.301587301587302 - 0.0864878339879762 = 0.215099 pu$$

Next calculate the critical clearing angle,

$$\delta_0 = 10.0242^\circ = 0.1749 rad$$

$$\delta_{max} = 180^\circ - \sin^{-1} \frac{1.16574}{4.8414}$$

$$= 180^\circ - 13.9329 = 166.0671^\circ = 2.8984 rad$$

$$\cos \delta_c = \frac{P_m(\delta_{max} - \delta_0) + P_{3max} \cos \delta_{max} - P_{2max} \delta_0}{P_{3max} - P_{2max}}$$

$$= \frac{1.16574(2.8984 - 0.1749) + 4.8414 \cos 166.0671^\circ - 0.8709 \cos 10.0242^\circ}{4.8414 - 0.8709}$$

$$= \frac{-2.3816}{3.9705} = -0.5998$$

$$\delta_c = \cos^{-1}(-0.5998) = 126.86^\circ$$

By using the same formula can also be calculated for other generators. The following shows the results of calculations in the table.

Table 5. Result of all generator using proposed method

Generator ID	Condition	S _{load} (MVA)	S _{loss} (MVA)	X _{equivalent} (pu)
Bakuru	Before Fault	116.574-j20.606	6.653-j18.011	0.173067
	During Fault	121.063-j20.292	42.353+j134.718	1.195653
	After Fault	121.063-j20.292	6.792-j13.032	0.215099
Pare	Before Fault	11.178+j28.742	0.065-j40.54	2.070677
	During Fault	11.609+j28.303	22.527+j54.211	12.12617
	After Fault	11.609+j28.303	0.081-j36.07	2.478995
Suppa	Before Fault	53.198-j14.409	1.257-j38.228	1.774859
	During Fault	55.247-j14.189	22.934+j59.591	4.864897
	After Fault	55.247-j14.189	1.244-j33.64	1.999389
Barru	Before Fault	36.143+j27.173	0.347-j39.777	1.894618
	During Fault	37.535+j26.758	26.734+j74.167	7.330431
	After Fault	37.535+j26.758	0.349-j35.354	2.176178
Sengkang	Before Fault	183.59-j5.501	11.205+j13.611	0.191544
	During Fault	121.063-j20.292	66.252+j233.149	1.698509
	After Fault	190.661-j5.417	14.549+j28.566	0.229717

From the calculation results obtained chart at the following broad criteria.

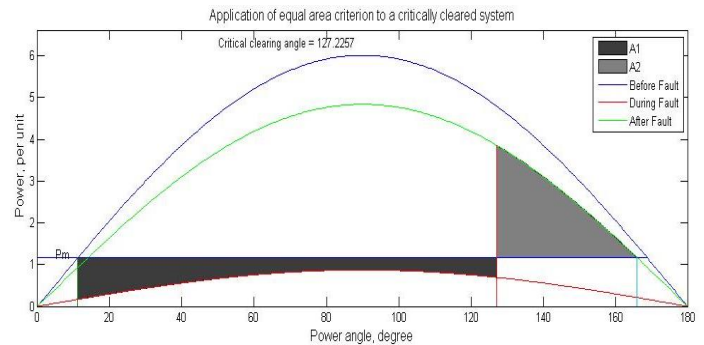

Figure 6. Equal area criterion for Bakuru Hydro Plant

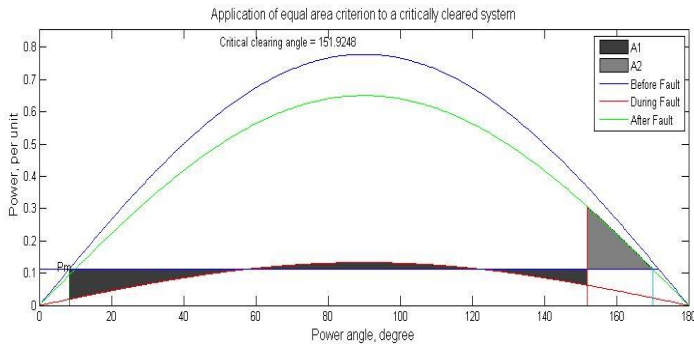

Figure 7. Equal area criterion for Pare Hydro Plant

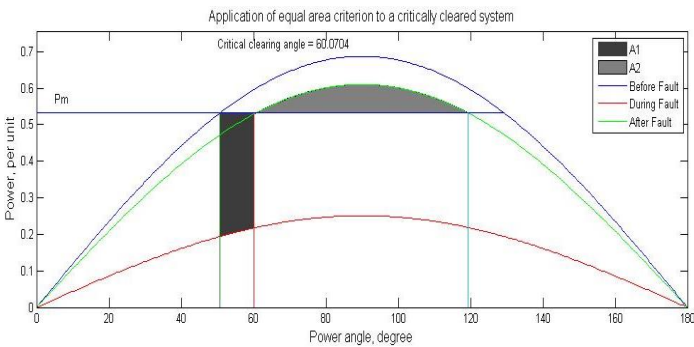

Figure 8. Equal area criterion for Suppa Diesel Plant

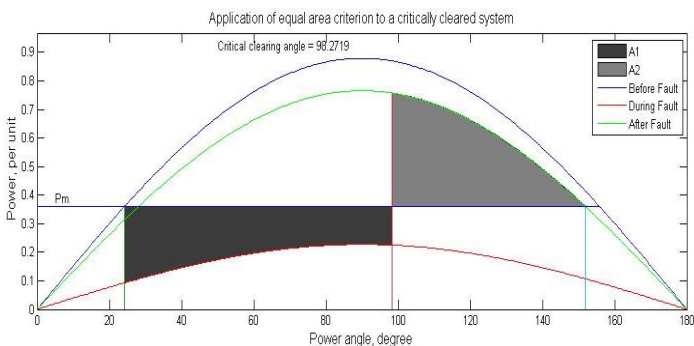

Figure 9. Equal area criterion for Barru Steam Plant

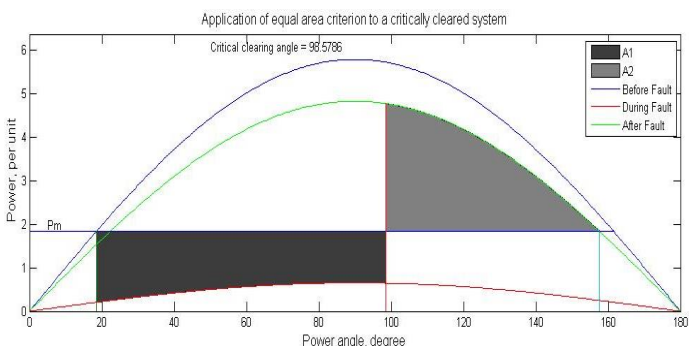

Figure 10. Equal area criterion for Sengkang Steam-Gas Plant

VI. CONCLUSION

From the analysis it can be concluded the use of this method is quite accurate in analyzing or calculating the stability of South Sulawesi generator system using P_{loss} and Q_{loss} to

calculate the equivalent impedance at each loading condition, before, during and after short circuit.

VII. REFERENCES

- [1] Robandi, I, *Modern Power System Design*, Andi Publisher. 2006.
- [2] Robandi, I, *Modern Power System Control*, Andi Publisher. 2006.
- [3] Lu Fang, *Transient stability analysis with equal area criterion directly used to a non-equivalent generator pair*, Power Engineering Energy and Electrical Drives, POWERING. 2009.
- [4] Xue, Y. *A simple direct method for fast transient stability assessment of large power systems*, Power Systems, IEEE Transactions on. 1988.
- [5] Xue, Y. *Extended equal area criterion justifications, generalizations, applications*. Power Systems, IEEE Transactions on. 1989.
- [6] Rahimi, A. *Generalized equal-area criterion: a method for on-line transient stability analysis*, Conference Proceedings, IEEE International Conference on. 1990.
- [7] Fang Da-Zhong. *Fast transient stability estimation using a novel dynamic equivalent reduction technique*. Power Systems, IEEE Transactions on. 1994.
- [8] Chiodo, E. *Transient stability evaluation of multimachine power systems: a probabilistic approach based upon the extended equal area criterion*. Generation, Transmission and Distribution, IEEE Proceedings. 1994.
- [9] Khan, A.Z. *PC based software package for the equal area criterion of power system transient stability*, Power Systems, IEEE Transactions on. 1998.
- [10] Chan, K.W. *Transient stability margin assessment for large power system using time domain simulation based hybrid extended equal area criterion method*. 2000.
- [11] Takaeue, J. *Transient stability preventive control using critical clearing time sensitivity*. Transmission and Distribution Conference and Exhibition : Asia Pacific. IEEE / PES. 2002.
- [12] Segui, T.C. *A new implemented pole slipping protection algorithm using the equal area criterion*. 2004.
- [13] Raju, R.G.G. *Transient stability analysis employing Equal Area Criterion*. Electrical Energy Systems (ICEES), 1st International Conference on. 2011.
- [14] Minghui Yin. *An Improved Iterative Method for Assessment of Multi-Swing Transient Stability Limit*. Power Systems, IEEE Transactions on. 2011.
- [15] Yusheng Xue. *Effective and robust case screening for transient stability assessment*, Bulk Power System Dynamics and Control - IX Optimization, Security and Control of the Emerging Power Grid (IREP), IREP Symposium. 2013.
- [16] Djalal.M.R.,” *Penyelesaian Aliran Daya 37 Bus Dengan Metode Newton Raphson (Studi Kasus Sistem Interkoneksi 150 kV Sulawesi Selatan)*. Jurnal Teknik Mesin SINERGI. 2014.
- [17] Djalal.M.R.,” *Studi Hubung Singkat 3 Fasa Simetri (Studi Kasus Sistem Interkoneksi 150 kV Sulselrabar)*. Seminar Nasional UNDA. 2014.