



Provided by the author(s) and University College Dublin Library in accordance with publisher policies. Please cite the published version when available.

Title	An assessment of the impact of wind generation on system frequency control
Authors(s)	Doherty, Ronan; Mullane, Alan; Nolan, Gillian (Lalor); Burke, Daniel J.; Bryson, Alexander; O'Malley, Mark
Publication date	2010-02
Publication information	IEEE Transactions on Power Systems, 25 (1): 452-460
Series	Electricity Research Centre(ERC)
Publisher	IEEE
Link to online version	http://dx.doi.org/10.1109/TPWRS.2009.2030348
Item record/more information	http://hdl.handle.net/10197/2353
Publisher's version (DOI)	10.1109/TPWRS.2009.2030348

Downloaded 2022-08-22T22:12:58Z

The UCD community has made this article openly available. Please share how this access benefits you. Your story matters! (@ucd_oa)



An Assessment of the Impact of Wind Generation on System Frequency Control

Ronan Doherty, *Member, IEEE*, Alan Mullane, Gillian (Lalor) Nolan, *Member, IEEE*, Daniel J. Burke, *Student Member, IEEE*, Alexander Bryson, and Mark O'Malley, *Fellow, IEEE*

Abstract—Rising wind generation penetrations and the distinctive inertial characteristics of associated turbine technology will impact system frequency control. While wind production will displace conventional synchronous plant, empirical study data presented also suggest that the relationship between the total stored turbine kinetic energy and the total system power production for wind is a variable that exhibits significant nonlinearity. Changing trends in system frequency behavior of a power system following the loss of the largest generator are studied in detail here, using simplified frequency control models and extensive simulations of wind penetration scenarios over an extended multiyear timeframe. The system frequency response is characterized by the rate of change of frequency and the frequency nadir. Results show that increasing levels of doubly fed induction generators and high-voltage dc interconnection alter the frequency behavior significantly, and that system operators may have to be proactive in developing solutions to meet these challenges.

Index Terms—Frequency control, power generation dispatch, power system security, wind power generation.

I. INTRODUCTION

CONTROLLING system frequency is a critical aspect of power system security. A secure power system should be able to withstand the loss of the largest online generator during normal operating conditions and thus prevent unnecessary load shedding or system collapse. While sizeable frequency deviations are rare in large heavily interconnected systems, frequency control is much more challenging in smaller isolated systems. Power system generation portfolios are changing rapidly and the inertial and dynamic characteristics of many new sources of generation differ from those of the past. Concerns over the potentially adverse effects of climate change and the requirement

to diversify energy supply portfolios have led to the rapid expansion of the renewable electrical energy industry in recent times [1]. For energy resource and technology maturity reasons, it is expected that wind power will supply the majority of future renewable penetration targets in many countries [2].

The differing operating characteristics of wind turbines compared with synchronous generators, particularly with respect to inertial response, has caused concern in electricity systems with increasing penetration of wind generation. In isolated systems which already have a relatively small inertial base, these changes in generator characteristics may pose challenges to operators trying to control system frequency. While fixed speed wind turbines [squirrel-cage induction generators (SCIG)] make their stored kinetic energy available to the system during frequency events (inertial response), variable speed wind turbines [doubly-fed induction generators (DFIG) and full convertor designs] generally do not [3]. It has been shown however that through the addition of a control loop, variable speed wind turbines may be configured to emulate an inertial response similar to that of synchronous generation [4], [5], and can be used to provide primary frequency control [6], [7].

Previous work assessed the impact of wind generation on system frequency during significant frequency events [8]. Wind penetrations and ratios of wind technologies (DFIG/SCIG) were assessed for frequency control performance under three deterministic system conditions: winter-day-peak, summer-night-valley, and summer-day-peak. While these results give insight into the effect of wind generation on the system frequency during specific system events, no conclusion can be made as to the impact of the wind generation on the overall power system reliability. The variable nature of wind generation, in addition to its interaction with other important factors such as load level and conventional plant dispatch, means that deterministic snapshots of specific system operating points cannot comprehensively describe the overall impact of wind generation on the reliability of the electricity system over extended periods. An assessment of system performance over a larger number of sample hours also facilitates an identification of the extremity and probability of any possible worst-case scenarios. While a simple system dispatch over the studied timeframe will directly imply the inertial contribution of synchronous conventional plant, a key parameter of consideration for system dynamic response models requiring a probabilistic assessment is the actual number of wind turbines that are in operation, and thus available for inertial response, at different levels of total system wind power production.

Manuscript received July 01, 2008; revised May 01, 2009. First published October 16, 2009; current version published January 20, 2010. This work was conducted in the Electricity Research Centre, University College Dublin, Ireland, which is supported by Airtricity, Bord Gais, Bord na Mona, Cylon Controls, the Commission for Energy Regulation, Eirgrid, ESB International, ESB Networks, ESB Powergen, Siemens, South Western Services, and Viridium. The work of D. J. Burke was supported by Sustainable Energy Ireland through a postgraduate research scholarship from the Irish Research Council for Science Engineering and Technology. The work carried out in this paper in no way reflects the views of Airtricity, EirGrid, Ecar Energy, or Hibernian Wind Energy. Paper no. TPWRS-00530-2008.

R. Doherty and A. Bryson are with Airtricity, Dublin, Ireland (e-mail: ronandoherty@yahoo.com; alex.bryson@airtricity.com);

A. Mullane is with Ecar Energy Dublin, Dublin, Ireland (e-mail: alan.mullane@ecarenergy.com);

G. Nolan is with EirGrid, Dublin, Ireland (e-mail:gill.nolan@eirgrid.com);

D. J. Burke and M. O'Malley are with the Electricity Research Centre, Department of Electrical and Electronic Engineering, University College Dublin, Dublin 4, Ireland (e-mail: daniel.burke@ucd.ie, mark.omalley@ucd.ie).

Digital Object Identifier 10.1109/TPWRS.2009.2030348

This paper proposes and implements a time series sampling methodology over an extended timeframe to assess the impact of increased penetrations of wind generation on the ability of the power system to cope with any “ $N - 1$ ” generation contingencies in a secure manner. The study focuses on two important indices of dynamic system frequency security, namely the maximum rate of change of frequency (ROCOF) and the minimum value of frequency recorded, the nadir. A number of possible future power system generation portfolio scenarios are analyzed, with several wind penetration levels, different types of wind turbine technology employed, as well as greater amounts of external HVDC interconnection (often proposed in isolated systems as a means to mitigate wind variability/uncertainty and to increase security of supply, but which does not provide additional inertia). Simplified dynamic models must be used for the extensive time series analysis as proposed in this paper. While such models give specific results of an approximate nature only, a good indication of the qualitative trends in system dynamic reliability will nonetheless result.

Section II of this paper presents empirical data outlining the stored kinetic energy potential of installed wind turbines, and its possible contribution to system frequency control. Section III describes the frequency response modeling framework applied in this paper—this includes detail of both the dynamic and the dispatch models. Section IV describes the study scenarios of the Irish All-Island system used as the test case for this analysis. Section V gives results followed by a discussion in Section VI. Section VII presents the paper’s main conclusions.

II. WIND POWER AND STORED KINETIC ENERGY

A key consideration in an assessment of increasing wind energy penetration levels is the inertial contribution of the wind generation connected to the system. With conventional generation, the inertial response of the units is reasonably easy to define using the nameplate information—a system dispatch will determine the units that are connected, spinning, and therefore contributing to the kinetic energy of the system. A system dispatch however will not specify the exact number of wind units which are spinning online, and thus in a position to contribute to the system kinetic energy. Due to the variable nature of wind power production and the geographical distribution of wind turbines, the process for determining the wind turbines that are connected and spinning at any one time is somewhat more problematic. Most wind turbines, even the most modern devices, generally rotate at a speed which is within a tight range, typically 15–19 rpm. Thus in order to approximate the kinetic energy contribution in the wind generation capacity, it can be deemed unnecessary to consider the actual speed of rotation of the wind turbines, but simply whether or not the turbines are rotating. To this end, individual wind turbine operation must be assessed with data from several geographically distinct farms. The expected proportion of wind turbines operating above their “cut-in” wind speed can then be expressed as a function of the total power generation output of the entire fleet of turbines. The empirical results of such an assessment are presented in Fig. 1. The data used to compile the model depicted in Fig. 1 were based on real

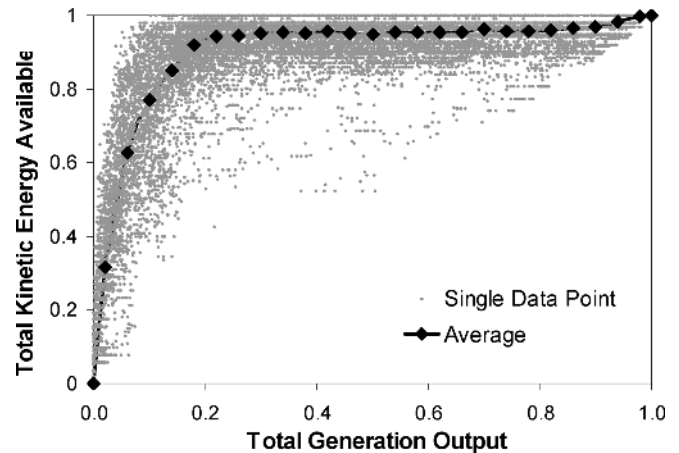

Fig. 1. Kinetic energy potentially available from wind generation as a function of wind generation output (all data normalized to unity).

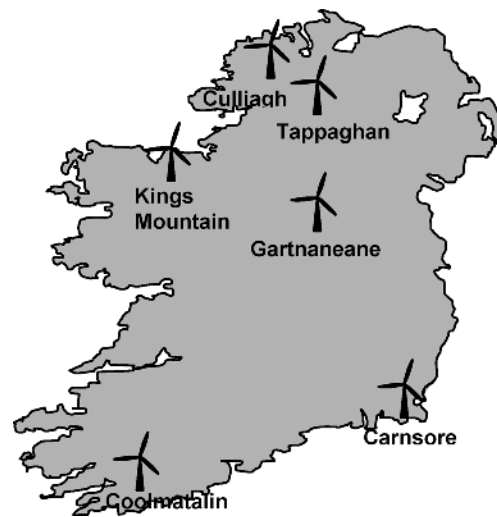

Fig. 2. Wind farms used in the assessment of stored kinetic energy.

wind turbine operational data (multiyear, 10-min resolution data from the existing Irish wind farms as illustrated in Fig. 2).

In contrast to the total stored kinetic energy of the conventional plant on a system, the corresponding relationship for total wind power production exhibits significant nonlinearity. This has potentially profound implications for dynamic frequency response behavior on the system. Fig. 1 shows that when the total generated wind power output on the island is greater than approximately 20% of the total installed wind capacity, it is very likely that over 90% of the wind turbines on the island are spinning and capable of providing kinetic energy to the power system during a frequency deviation event (assuming kinetic energy can actually be dynamically transferred to the system as in the case of an SCIG or modified DFIG machine [3], [4]).

For subsequent increases above 20% of rated system wind power output, there is generally no extra stored wind turbine kinetic energy added to the system. While both medium and high wind power outputs may have similar inertial contributions, the modification of total system stored kinetic energy is not the same as different amounts of conventional plant are displaced in the resulting system dispatch. As the total wind power

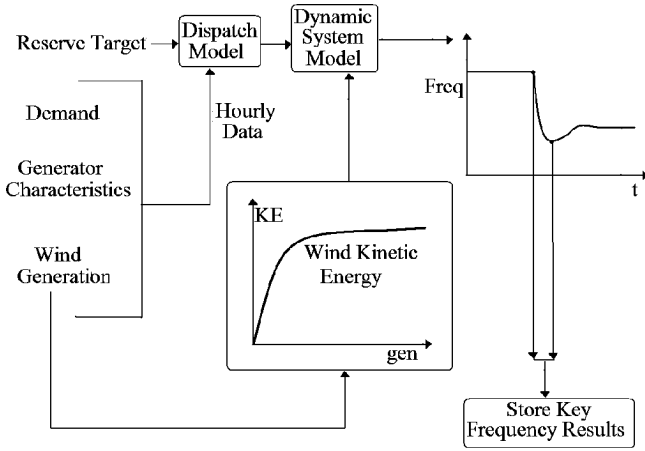

Fig. 3. Frequency control study modeling framework.

production at any one time is a variable, a frequency control analysis incorporating the characteristic of Fig. 1 requires repeated dynamic simulation under different load conditions over an extended timeframe.

III. MODELING FRAMEWORK

The methodology applied in this paper is designed to capture the key aspects of power system operation that affect system frequency response following the loss of a large generator. An outline of the framework is illustrated in Fig. 3.

A. Model Configuration and Inputs

While previous deterministic studies used specific single event cases [8], the processing of a large number of cases in this methodology is crucial to enable the correct identification of the principal statistics and features from the resulting outputs. Important variables such as wind power generation level, conventional generator availability and cost characteristics, load demand level, and the primary reserve target are fed into a dispatch model on an hourly basis. The system dispatch data, along with the expected number of wind turbines spinning, as illustrated in Fig. 1, are input to the dynamic model. This process is sequentially repeated over a significantly long timeline to generate a thorough representation of the statistical properties of the principal outputs. Load and wind time series were taken from historical data recorded synchronously at hourly resolution over an extended multiyear period. This preserves to the maximum extent possible any natural statistical interdependencies present in the real system inputs. Other system inputs such as generator dynamic model parameters and costs were based on typical generators present in the Irish All-Island system in order to keep the modeling and results as illustrative as possible of real power system operation.

B. Dispatch Model

The dispatch model determines the generation units that are running on the system in each hour, their operating level, and their quantity of reserve being provided. The system dispatch strategy in this paper applies a linear programming (LP) model to co-optimize the energy and reserve levels from the units on

the system (coupling of hours through individual unit commitment was not modeled here—this was deemed to be acceptable for the overall system operational scope of the study applied in this paper). The problem of ensuring feasibility in a co-optimized LP market dispatch is well documented [9]. The minimum operating point of generators requires that discrete decisions be made about the on or off status of the units. This problem was overcome using a two-stage rounded linear relaxation technique as detailed in [10]. Unit operating points and reserve levels are co-optimized to find a least cost solution on an hourly basis. Units are assumed to have single bids per unit of energy and reserve. The control variables in this dispatch formulation are:

- P_i , the power from each unit i (wind was modeled by a priority dispatch unit with an upper limit as defined by the historical wind power time series for that hour);
- R_i , the primary reserve from each unit. The reserve output from each unit was defined to be the maximum increase in output the unit could produce 5 s after a contingency.

The aim is to minimize the objective function in (1), where bp_i and br_i are the energy and reserve bids of generator i , and N is the number of generators. br_i is derived on a cost basis which is reflective of the incremental cost of providing a MWh of reserve. This figure is small, in the range of 1-2 €/MWh as is intended to reflect the increased wear and maintenance costs that can be incurred by providing reserve ramp-up. Neglecting system losses, the objective function is subject to the load balancing constraint, and the satisfaction of the system reserve requirement, as applied in (2) and (3), where L is system load. Typically the reserve requirement is represented by several constraints across different timeframes from fast to slow. Here for simplicity, only the fastest (primary reserve) requirement is modeled, as the region of interest is in the period of time immediately following a contingency (typically within about 5 s of a generator trip-event for the Irish All-Island system under consideration in Section IV). The unit characteristics are included with constraints (4)–(7), where $Pmin_i$ and $Pmax_i$ are the minimum and maximum power output of unit i , and $Rmax_i$ is the maximum reserve available from unit i in the primary reserve time frame and $Rslope_i$ is the slope of the reserve supply constraints, as defined in Fig. 4:

$$\min \left(\sum_{i=1}^N bp_i P_i + \sum_{i=1}^N br_i R_i \right) \quad (1)$$

$$\sum_{i=1}^N P_i = L \quad (2)$$

$$\sum_{i=1}^N R_i = \text{Reserve Requirement} \quad (3)$$

$$0 \text{ or } Pmin_i \leq P_i \leq Pmax_i \quad (4)$$

$$0 \leq R_i \leq Rmax_i \quad (5)$$

$$P_i - \frac{1}{Rslope_i} R_i \leq Pmax_i \quad (6)$$

$$-\frac{Rmax_i}{Pmin_i} P_i + R_i \leq 0, \quad (7)$$

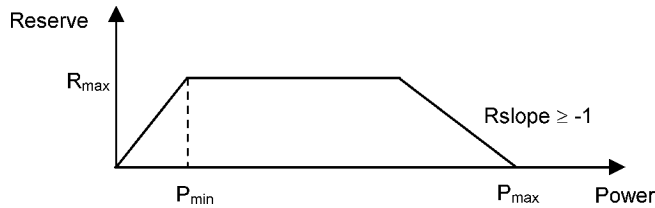

Fig. 4. Unit power and reserve characteristics.

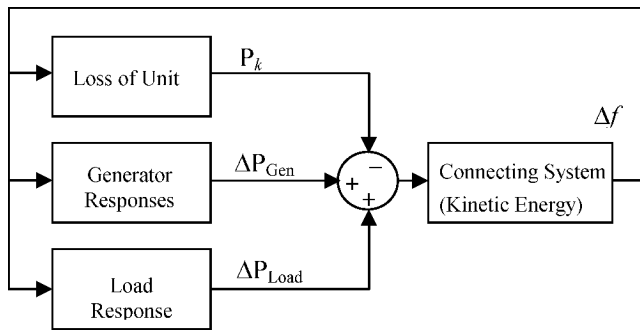

Fig. 5. Simplified frequency control model representation.

C. Dynamic System Model

The hourly generation dispatches are utilized by the dynamic system frequency model to assess the likely response of the system to serious frequency events such as the loss of a large generator. Conventional unit and load inertial responses are included in the model as well as any possible inertial contribution from wind generation. The unit dynamic models are configured to have reserve characteristics that correspond to the unit reserve capabilities in the dispatch model.

1) *Simplified Generator and Load Models*: A detailed single bus-bar model of the Irish power system was developed, validated, and used in a number of studies [8], [10], [11], to model the response of the Irish system frequency to supply/demand imbalances. Each generator on the system, including wind generators, was represented by a dynamic model with system frequency as an input, as shown in Fig. 5. At nominal frequency, each generator model is in steady state and power output is constant. When a dynamic power system imbalance occurs, a frequency deviation from nominal will result. A variation in power output from each generator model may occur as a consequence of the frequency deviation, dependent on the steady-state set-point and the droop setting. The power differentials from each generator model and the representative load model are summed, and from this resultant power value, the variation in system frequency from nominal is calculated with knowledge of the synchronous kinetic energy in the system (denoted by “connecting system” in Fig. 5).

In order to carry out assessments over yearly timeframes at hourly resolution incorporating characteristics such as that in Fig. 1, a large number of simulations is required. To facilitate the running of such a large number of scenarios within a practical computational timeframe, simplifications were introduced to the original validated single bus-bar model of [8], [10], and [11]. While the validated system model represented the dynamic characteristics of each individual unit on the system, this study

uses a single unit model to represent the dynamic characteristics of each generator type within the system model. This reduces a dynamic system having over 30 models of individual conventional generation units to a system having five dynamic models (combined cycle gas turbine, open cycle gas turbine, steam turbine, wind turbine, and the load model), with the associated benefits of computational speed. Model accuracy may suffer as a result of these simplifications; however, a qualitative indication of changing dynamic response reliability caused by increasing wind generation and characteristics such as Fig. 1 is the principal aim of this study. Precise quantitative results for specific “snapshot” events and the accurate modelling procedures required to produce them are extensively detailed in [8], [10], and [11].

The dispatch model described in Section III-B was based on the maximum reserve available from each generator type after 5 s. The dispatch model was validated to ensure that the maximum reserve available after 5 s was consistent with the simplified dynamic model. This validation was achieved by examining a number of dispatches produced by the dispatch model. The load model (a first-order transfer function) and the connecting system were not simplified from the single bus-bar model, and their dynamic model parameters applied are as detailed in [8], [10], and [11].

2) *Simplified Wind Turbine Model*: Previous work presented the performance of dynamic models of wind turbines in conjunction with the full system model [8]. The previously used fifth- and third-order induction machine-based models were simplified by using a first-order wind turbine model in this study, having a linear torque slip characteristic represented by a static gain. For the purposes of this study, this first-order model was found to be sufficient to represent the primary dynamic of interest in the first 5 s following a frequency event, namely the relationship between a deviation in system frequency and the power output of the turbine due to changes in kinetic energy. A governor response was not included in the wind turbine models although it is recognized that such response is possible [6], [7]. Similar to the approach for conventional units, the entire SCIG wind capacity on the system was represented by a single per-unit 1-MW induction machine model, with the output scaled by the installed SCIG capacity. The wind-dependent kinetic energy contribution was factored into the per-unit wind-turbine model by appropriately modifying its inertial response as a function of the total production from SCIG wind turbines, based on the average relationship as described in Fig. 1. As both medium and high wind power production levels will have approximately the same fraction of turbines actually spinning, their per-unit inertial responses to a system frequency drop are scaled by almost the same fractional proportion, as implied by Fig. 1. For DFIG (or full converter designs), the kinetic energy contribution was assumed negligible, as shown in [3].

D. Output Data

The study methodology provides a set of outputs for every hour of multiple years’ length of simulations. From each hourly run of the model, the key indices of dynamic system performance were stored. These included the frequency nadir and

the maximum ROCOF following the loss of the largest unit. In the case of the maximum ROCOF, it was intended that the maximum ROCOF would be equivalent to that measured over a number of ac frequency cycles by a protection relay. The recorded value was thus taken as the maximum value of a low-pass-filtered representation of the simulated ROCOF.

IV. TEST SYSTEM AND SIMULATION SCENARIOS

The study methodology presented in Section III was applied to the Irish “All-Island” electric power system as a test case. The Irish All-Island electricity system is a small, isolated system, consisting of two ac interconnected power systems of nominal frequency 50 Hz, operated by the System Operator for Northern Ireland (SONI) and EirGrid. Frequency control has always been an important issue on the All-Island system, as it is an isolated system where a single unit can be providing up to 10%-15% of the generation at certain times. The test system examined here is based on projections of the All-Island system in 2010. The demand level was assumed to be 45 TWh over the entire year with a peak demand of 7612 MW.

The system in 2010 is projected to have an installed capacity of approximately 9000 MW with just one 500-MW HVDC inter-connector to Scotland. Reheat and non-reheat thermal generators, simple open-cycle gas turbines (OCGT), combined-cycle gas turbines (CCGT), and limited hydroelectric generation, along with a single pumped storage station comprise the conventional generation on the All-Island system at present. The All-Island system generation portfolio is currently changing with projections of a significant amount of new-build CCGT plant in the near future. Forecasted additions to the generation fleet are also accounted for in the test system. Details of the HVDC interconnection and unit characteristics (including fuel costs, etc.) were supplied by the system operator in the Republic of Ireland [12]. Units’ bids are assumed to be the short-run cost of energy production. The availability and operation of the single pumped storage plant and the energy-constrained hydro generators was modeled based on their historic operational trends, as they are minor elements in the overall generation system portfolio (hydro typically contributes ~1%-2% of energy production—in systems with significant installed hydro, then a full detailed study of its operation and dynamic response would be required). A summary of the 2010 large-scale conventional plant portfolio assumed is provided in the Appendix section (Table III).

Typically the largest in-feed on the All-Island system which is treated as a single contingency is 400 MW. The interconnector is only operated at a maximum of 400 MW as the instantaneous contingency loss of larger amounts is deemed to be unacceptable by the system operators and henceforth will be referred to as 400-MW interconnection. Seventy-five percent of this figure is generally used as a primary reserve target on the system, i.e., reserve which acts within 5-15 s of an event. There is no automatic generator control (AGC) on the All-Island power system at present. The effects of wind variability and forecasting error have been shown to have a negligible impact on the requirement for primary operating reserve (POR) [13]. Therefore, a POR target of 300 MW was used in the model simulation here, which tested the instantaneous loss of a 400-MW in-feed for

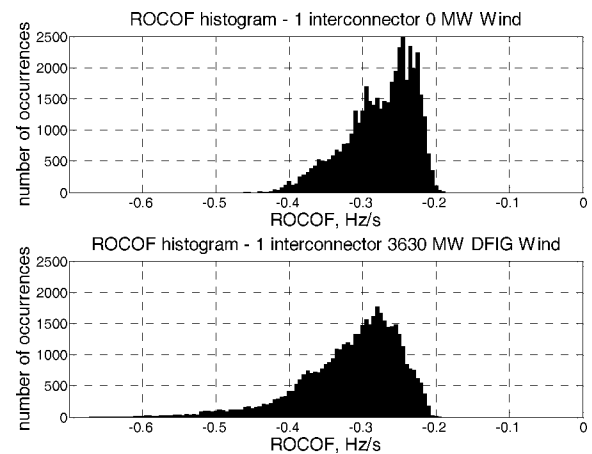

Fig. 6. Maximum ROCOF histograms—DFIG wind turbine penetration.

each hourly case of the study scenarios. Static reserve (that automatically trips following a predefined frequency level drop) is available from pumps and excess interconnection capacity.

In 2008, the installed wind capacity on the All-Island system was approximately 920 MW, and in the region of an additional 580 MW is currently in various stages of planning and installation, with many more additional applications for connection being processed. There is a government target of 40% renewable electrical energy (approximately 5.5–6 GW installed wind capacity) by 2020 [14]. At present, 20% of the installed wind capacity is of the SCIG type, the remainder being mainly DFIG technology. The inertia constant H for wind turbines was taken to be 2.5 s [15] which compares with larger values for most conventional plant of 4–10 s. Several wind scenarios were examined with the model. These included systems with 0, 1742, and 3630 MW of either all SCIG or all DFIG wind capacity. Scenarios were also tested with HVDC inter-connector capacity increased from 400 MW to 800 MW. The combination of these factors results in a total of ten different scenarios, with each scenario run for five years of hourly data. The modeling framework outlined here was implemented in MATLAB using the optimization toolbox and SIMULINK.

V. RESULTS

A. ROCOF Results

From the database of recorded results, illustrative histograms describing ROCOF performance are given in Fig. 6 for two of the scenarios. The histograms illustrate the notable impact of DFIG wind penetration upon maximum ROCOF, markedly skewing it to the left. The proportion of cases where the ROCOF fell below -0.4 Hz/s is summarized for all the study scenarios in Table I. The -0.4 Hz/s reference was chosen as it is representative of the level below which conventional generator ROCOF protection relays would activate tripping more generation. It should be noted that the percentage values should be interpreted as the percentage of hours the ROCOF would fall below -0.4 Hz/s if there was an instantaneous outage of 400 MW of generation at the same time.

The effect of both SCIG and DFIG types of wind penetration, and extra HVDC inter-connection is to displace synchronous

TABLE I
IMPACT OF WIND PENETRATION ON MAXIMUM ROCOF

Scenario	% of Hours With a ROCOF < -0.4 Hz/s	
	DFIG Wind	SCIG Wind
400 MW HVDC Inter-connector 0 MW Wind	0.7 %	
400 MW HVDC Inter-connector 1742 MW Wind	2.1%	0.9%
400 MW HVDC Inter-connector 3630 MW Wind	10%	5.5%
800 MW HVDC Inter-connector 0 MW Wind	2.1%	
800 MW HVDC Inter-connector 1742 MW Wind	5.3%	3.2%
800 MW HVDC Inter-connector 3630 MW Wind	17.5%	10.6%

spinning conventional units and their associated inertia. However, it can be seen from the results (Table I) that SCIG units have significantly less impact on ROCOF than DFIG units, as the SCIG machines do provide some inertial response in the time period in which the ROCOF is measured. The results indicate that one more 400-MW inter-connector has the same impact as 1742 MW of DFIG wind capacity in this regard (i.e., 2.1% of hours have a ROCOF of -0.4 Hz/s or less). Due to high capacity factors (30%–35%) in Ireland, the average energy provided by 1742 MW of wind capacity is greater than that provided by 400 MW of HVDC interconnection capacity, yet the results of this study indicate that their impact on maximum ROCOF is similar. This is in part due to the fact that wind power output levels in Ireland are on average higher during the winter and during the day time hours when demand is higher, and hence, there is a higher synchronous inertial response.

The results indicate that the probabilistic inter-dependence of key system variables such as wind output, load demand, and conventional plant power production is significant, and can only be properly captured with the extensive time-series sampling approach as applied in this paper.

B. Frequency Nadir Results

1) *Nadir Statistics*: From the database of recorded results, illustrative histograms describing nadir performance are given in Fig. 7 for two of the scenarios. The impact of DFIG wind penetration is to have a noticeable “spreading” effect in both the positive and negative directions. The changes in nadir are due to the differing dispatches with wind power, i.e., modified levels of system inertia and the different dynamic responses of the units proving reserve. The proportion of cases where the nadir reached a frequency below a 49.3-Hz reference point is summarized for each of the scenarios in Table II. The level of 49.3 Hz was chosen as the benchmark as it is the point where automatic load shedding occurs on the Irish system.

Again, it should be noted that given the somewhat simplified nature of the dynamic models, the percentage values should be interpreted mainly as an indication of the percentage of hours the nadir would be below 49.3 Hz if there was an instantaneous outage of 400 MW of generation at each hour simulated.

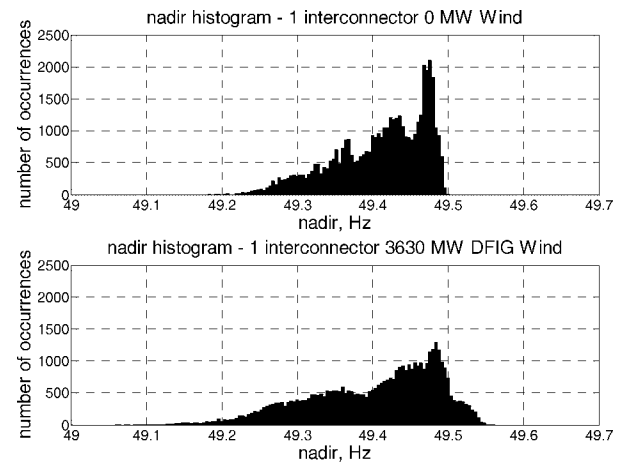

Fig. 7. Nadir histograms—DFIG wind turbine penetration.

TABLE II
IMPACT OF WIND PENETRATION ON FREQUENCY NADIR

Scenario	% of Hours With a Nadir < 49.3 Hz	
	DFIG Wind	SCIG Wind
400 MW HVDC Inter-connector 0 MW Wind	6.2%	
400 MW HVDC Inter-connector 1742 MW Wind	7.8%	2.3%
400 MW HVDC Inter-connector 3630 MW Wind	13.9%	1.8%
800 MW HVDC Inter-connector 0 MW Wind	8%	
800 MW HVDC Inter-connector 1742 MW Wind	10.6%	4.6%
800 MW HVDC Inter-connector 3630 MW Wind	18.3%	5.5%

It can be seen that while increasing penetrations of DFIG wind generation capacity have an adverse impact on the frequency nadir, the opposite is generally true for the SCIG wind penetration. Again it can be seen that the adverse impact of 400 MW of additional HVDC interconnection is similar in magnitude to that of 1742 MW of DFIG wind capacity, i.e., 8% versus 7.8% of hours with a nadir less than 49.3 Hz. This case represents over 600 h/year where there is a potential problem if a large contingency occurs. It can also be seen that there is a significant impact in terms of the increasing likelihood of extreme events on the system with increasing interconnection and DFIG wind capacity. With 800 MW of HVDC interconnection and 3630 MW of DFIG wind capacity, results indicate that it is three times more likely that if a 400-MW contingency occurs the nadir will be below 49.3 Hz than the case with 0-MW wind capacity and 400 MW of HVDC interconnector capacity, i.e., 6.2% compared to 18.3% (approximately 1600 h/year).

2) *“Fixed” POR Units Applied*: Detailed analysis of the frequency response nadir behavior indicated both the total system inertia and the POR plant dynamic characteristics as the most important factors of influence. The dynamic response of different types of reserve units to a frequency deviation can vary. While two units may have the same primary reserve capability

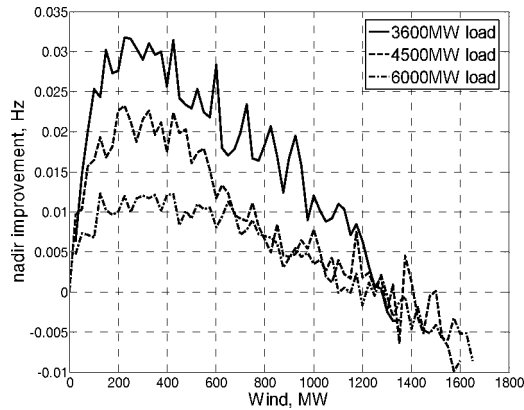

Fig. 8. Averaged nadir difference from the zero wind capacity study scenario, at different instantaneous load levels (3600 MW, 4500 MW, and 6000 MW) and variable wind output for 1742-MW SCIG total wind capacity (fixed POR).

definition in a dispatch model (i.e., typical response level at 5 s post-event), their response before and after can be different. Therefore, their energy contributions to dynamic frequency recovery can vary. It is this amount of energy that they contribute to the system that will mainly determine how they impact on the frequency nadir. Increasing wind penetration will alter the merit order and the type of unit generally providing primary reserve, and therefore, the combined dynamic frequency response of the system's conventional plant. Investigating this particular effect is an area of future work, as the simplified dynamic models applied in this paper would not be suitable for such a detailed study. As the reserve and inertial dynamic responses are separate factors which can be either contradictory or complimentary for each individual system hourly dispatch operating state, a separate scenario was investigated where the allocation of POR to each unit type present was fixed for all hourly cases (100-MW CCGT, 100-MW OCGT, 50-MW steam turbine, and 50-MW static inter-connector reserve), to study the impact of wind penetration on system inertia factors only. Conventional DFIG turbine technology due to its stator/rotor decoupling adds no useful kinetic energy to the system in terms of inertial response and is therefore detrimental to overall frequency response through conventional plant displacement. The impact of SCIG is interesting, however, as Fig. 8 illustrates.

A modest amount of SCIG power output will displace few if any conventional power units, but will add a considerable amount of its own kinetic energy, as illustrated by Fig. 1. The net effect on frequency nadir will be a positive one, as the combined total system inertia is greater than the no-wind case ("total system inertia" being a conceptual term here, as one cannot simply add synchronous and asynchronous inertial responses, due to their relative difference in speed of response). If SCIG wind power displaces inertia-less HVDC interconnector power in the dispatch, as may occur at lower load levels in the Irish All-Island power system, this effect will be magnified. A much larger amount of SCIG wind power output will displace a greater amount of conventional power, but will not add any additional system inertia (Fig. 1). Thus, the new total system inertia may be below the no-wind case total. There is thus a threshold amount

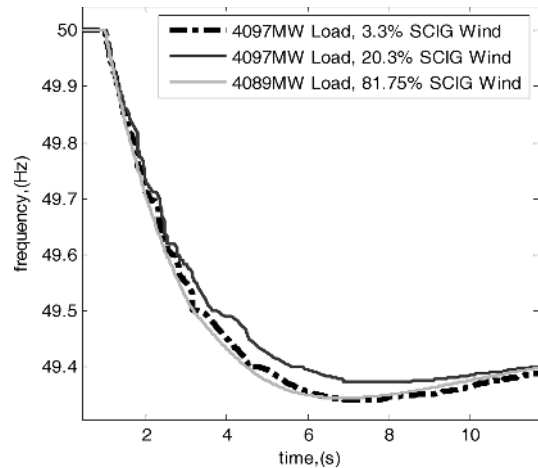

Fig. 9. Frequency response at similar load level for different wind power outputs with 3630-MW installed SCIG wind capacity (fixed POR allocation).

of SCIG wind generation output that will have a negative impact on frequency nadir as illustrated in Fig. 8. Sample frequency response deterministic events for the same load level at different levels of SCIG wind power output are illustrated in Fig. 9. Again, for a given amount of installed wind capacity (3630 MW), the frequency response at low to medium SCIG wind power output (20.3%) is better than at both the very low (3.3%) and very high (81.75%) wind power output levels.

VI. DISCUSSION

The empirical results of Fig. 1 outline the significant amounts of stored rotational kinetic energy in the total system's installed wind capacity even at low levels of overall wind power production, and thus the great potential of wind power to provide an inertial response if the correct turbine controller technology is employed. While there is significant SCIG wind turbine capacity worldwide, most new turbines being installed are typically of the DFIG type. The relevance attributed to Figs. 1, 8, and 9 in this paper is not redundant, however, as even DFIG turbines can be modified to emulate a much better controlled inertial response than SCIG turbines [3], [5], [16] and so the beneficial effect of the large amounts of stored rotational kinetic energy in wind turbines could be of significant importance if it were to be harnessed in a large-scale and effective manner.

The results of the frequency response study, under a number of possible future scenarios, indicate the net impact of increased wind and HVDC inter-connector capacity on key system security metrics regarding system frequency control (i.e., ROCOF and nadir). The more extreme maximum ROCOF and frequency nadir events that may occur in a future system with increasing amounts of DFIG wind penetration and greater HVDC inter-connection present significant challenges for system operators. The results show that both increased DFIG wind penetration and HVDC capacity have a detrimental effect on both maximum ROCOF and nadir performance, while the effect of SCIG wind is tempered by its inertial response and the characteristic illustrated in Fig. 1. Similar consequences would likely apply

to other power systems with plans to increase wind penetration levels.

Several steps may be required to mitigate the risks to system security in the future for power systems with high renewable penetration and increased HVDC interconnection. Results here indicate that a mix of SCIG and DFIG technology could help mitigate some of the impacts on frequency control in the short term, while still preserving some of the important advantages of DFIG converter control [17]. A method to adjust a fixed-speed wind farm's frequency protection relay settings on the basis of the system operating point is proposed in [18] to ensure wind generation remains connected following severe frequency excursions. With large amounts of wind and HVDC interconnector capacity on the system, it may also be necessary for system operators to specifically control key variables to ensure system security is maintained. Dispatch constraints that specifically dispatched the system in such a way so that certain maximum ROCOF and nadir criteria were met have been reported [10]. Of paramount importance in this approach is the dispatching down of the largest in-feeds in the system during hours of concern, thus reducing the size of the critical contingency should it occur. Solutions that dispatch units to provide additional inertial response and possibly curtailing wind generation and/or interconnector power may also be viable and need to be studied. Significant wind curtailment might not be acceptable in some systems, but may be most economic in certain rare circumstances. Other means of ensuring frequency stability for power systems in the future may be the installation of novel dedicated system inertia devices such as large flywheels [19], [20].

VII. CONCLUSIONS

The analysis in this paper applied extensive time series dispatch sampling, recorded historical wind turbine operating characteristics, and simplified dynamic simulation models to investigate the effects of changing plant portfolios on system frequency control in the isolated Irish "All-Island" power system. The overall consequences of increasing wind penetration and HVDC interconnection levels for the transient frequency response of the All-Island power system depend on system dispatch, reserve dynamic characteristics, and the form of wind turbine technology employed. Even at relatively low wind power output levels, empirical data collected suggest that there is likely a relatively large stored wind turbine kinetic energy resource available, provided the wind turbine technology can react appropriately to dynamic frequency excursions. It can be concluded however that a future power system with a significant level of DFIG wind penetration and greater levels of HVDC interconnection will present significant frequency control challenges to system operators. Time-series sampling studies such as applied here are required to correctly identify the changing trends and model the possible impact of any proposed solutions. While significant work still remains to be done in this field, the combined development of wind and HVDC interconnector capacity in the system will evolve gradually over the coming years, allowing for adaptive solutions to emerge.

TABLE III
2010 IRISH "ALL-ISLAND" GENERATION PORTFOLIO ASSUMED

Generation Type	Number of Units	Capacity (MW)
CCGT	10	2647
OCGT	9	671
HVDC Interconnector	1/(2)	400/(800)
Hydro	15	217
Pumped Hydro	4	+/- 292
<u>Steam Turbine:</u>		
Gas	7	850
Coal	5	1305
Oil/Distillates	10	1492
Peat	3	348

APPENDIX

A summary of the 2010 large-scale conventional plant portfolio assumed is given in Table III.

ACKNOWLEDGMENT

The authors would like to thank Eirgrid, Airtricity, and Hibernian Wind for their assistance during this work and S. Rourke (EirGrid) for his advice and expertise.

REFERENCES

- [1] Delivering Energy and Climate Solutions—EWEA 2007 Annual Report, European Wind Energy Association (EWEA), 2008. [Online]. Available: <http://www.ewea.org/index.php?id=178>.
- [2] Pure Power—Wind Energy Scenarios up to 2030, European Wind Energy Association (EWEA), 2008. [Online]. Available: <http://www.ewea.org/index.php?id=178>.
- [3] A. Mullane and M. J. O'Malley, "The inertial-response of induction-machine based wind-turbines," *IEEE Trans. Power Syst.*, vol. 20, pp. 1496–1503, 2005.
- [4] J. Ekanayake and N. Jenkins, "Comparison of the response of doubly fed and fixed-speed induction generator wind turbines to changes in network frequency," *IEEE Trans. Energy Convers.*, vol. 19, pp. 800–802, 2004.
- [5] J. Morren, S. W. H. de Haan, W. L. Kling, and J. A. Ferreira, "Wind-turbines emulating inertia and supporting primary frequency control," *IEEE Trans. Power. Syst.*, vol. 21, no. 1, pp. 433–434, Feb. 2006.
- [6] N. R. Ullah, T. Thiringer, and D. Karlsson, "Temporary primary frequency control support by variable speed wind turbines—Potential and applications," *IEEE Trans. Power. Syst.*, vol. 23, pp. 601–612, 2008.
- [7] J. M. Mauricio, A. Marano, A. Gomez-Exposito, and J. L. M. Ramos, "Frequency regulation contribution through variable-speed wind energy conversion systems," *IEEE Trans. Power. Syst.*, vol. 24, no. 1, pp. 173–180, Feb. 2009.
- [8] G. Lalor, A. Mullane, and M. J. O'Malley, "Frequency control and wind turbine technologies," *IEEE Trans. Power Syst.*, vol. 20, pp. 1903–1913, 2005.
- [9] A Co-Optimized Energy-Reserve Market—Frequently Asked Questions, Commission for Energy Regulation, 2003. [Online]. Available: <http://www.cer.ie/cerdocs/cer03300.pdf>.
- [10] R. Doherty, G. Lalor, and M. J. O'Malley, "Frequency control in competitive electricity market dispatch," *IEEE Trans. Power Syst.*, vol. 20, pp. 1588–1596, 2005.
- [11] J. O'Sullivan and M. J. O'Malley, "Identification and validation of dynamic global load model parameters for use in power system simulation," *IEEE Trans. Power Syst.*, vol. 11, pp. 851–857, 1996.
- [12] Market Simulation Model Validation, The All-Island Project Modelling Group. [Online]. Available: <http://www.allisland-project.org/en/modelling-group-minutes-presentations.aspx?article=43618f97-6118-40f1-9b56-18c500592c70>.
- [13] Operating Reserve Requirements as Wind Power Penetration Increases in the Irish Electricity System—Final Report, Sustainable Energy Ireland, 2004. [Online]. Available: <http://www.sei.ie/index.asp?docID=1&locID=330>.

- [14] Delivering a Sustainable Energy Future for Ireland, Irish Government White Paper, 2007. [Online]. Available: <http://www.dcmnr.gov.ie/Energy/>.
- [15] B. Fox, T. Littler, and D. Flynn, "Measurement-based estimation of wind farm inertia," in *Proc. IEEE PowerTech Conf.*, St. Petersburg, Russia, Jun. 27-30, 2005.
- [16] P.-K. Keung, P. Li, H. Banakar, and B. T. Ooi, "Kinetic energy of wind-turbine generators for system frequency support," *IEEE Trans. Power. Syst.*, vol. 24, no. 1, pp. 279–287, Feb. 2009.
- [17] E. Vittal, A. Keane, and M. J. O'Malley, "Varying penetration ratios of wind turbine technologies for voltage and frequency stability," in *Proc. IEEE PES General Meeting*, Pittsburgh, PA, Jul. 2008.
- [18] A. Sumper, O. Gomis-Bellmunt, A. Sudria-Adreau, R. Villafafila-Robles, and J. Rull-Duran, "Response of fixed speed wind turbines to system frequency disturbances," *IEEE Trans. Power. Syst.*, vol. 24, no. 1, pp. 181–192, Feb. 2009.
- [19] D. E. Hampton, C. E. Tindall, and J. M. McArdle, "Emergency control of power system frequency using flywheel energy injection," in *Proc. IEE Int. Conf. Advances in Power System Control, Operation and Management*, Hong Kong, Nov. 1991.
- [20] H. Akagi, "Large static converters for industry and utility applications," *Proc. IEEE* (invited paper), vol. 89, no. 6, pp. 976–983, Jun. 2001.



Ronan Doherty (M'03) received the B.E. degree in electronic engineering and the Ph.D. degree in power systems, markets, and wind generation from the University College Dublin, Dublin, Ireland, in 2001 and 2005, respectively.

Since then, he has worked in the electricity industry in Ireland completing work for the Economic and Social Research Institute and was involved with All-Ireland energy policy work for the respective governments. From 2005 to 2008, he worked with Airtricity Ltd., a successful developer of wind generation assets, with interest in Ireland, the U.K., the U.S., Continental Europe, and China. Positions included that of Risk Manager within Airtricity's Trading Department. He is currently Chief Technical Officer with Edinburgh-based Aquamarine Power Ltd., a world-leading marine renewables company developing both wave and tidal energy devices.

and control issues concerning the large-scale integration of renewable energy into power systems.



Alan Mullane received the B.E. degree in electrical and electronic engineering and the Ph.D. degree in electrical engineering from the Department of Electrical and Electronic Engineering at University College Cork, Cork, Ireland, in 1998 and 2003, respectively.

In 2004, he joined the Electricity Research Center at University College Dublin, Dublin, Ireland, as a Postdoctoral Research Fellow and subsequently a Lecturer. He is currently a Senior Consultant with Ecar Energy. His research interests include operation

and control issues concerning the large-scale integration of renewable energy into power systems.



Gillian (Lalor) Nolan (M'03) received the B.E. degree in mechanical engineering and the Ph.D. degree in power systems from University College Dublin, Dublin, Ireland, in 2001 and 2005, respectively.

The research was conducted in the Electricity Research Centre, University College Dublin. Since 2006, she has worked with EirGrid, initially on the development of the Single Electricity Market on the island of Ireland and now as a Principal Engineer in Ancillary Services in the area of System Operations.



Daniel J. Burke (S'07) received the B.E.E.E. degree in electrical and electronic engineering from University College Cork, Cork, Ireland, in 2006. He is currently pursuing the Ph.D. degree in power systems at the Electricity Research Centre in University College Dublin, Dublin, Ireland.

His main research interests are in probabilistic power system planning with increased penetration of wind energy.



Alexander Bryson received the B.A. degree from the University of Cambridge, Cambridge, U.K., in 1999.

He works in the Trading Department of Airtricity, the renewable energy company, in the area of long-term renewable energy agreements; he also has experience in pumped-storage generation.



Mark O'Malley (F'07) received the B.E. and Ph.D. degrees from University College Dublin, Dublin, Ireland, in 1983 and 1987, respectively.

He is a Professor of electrical engineering in University College Dublin and is the Director of the Electricity Research Centre, with research interests in power systems, grid integration of renewable energy, control theory, and biomedical engineering.