

An automated sound-localization chamber

GLENN C. THOMPSON, HENRY E. HEFFNER, and BRUCE MASTERTON
Department of Psychology, Florida State University, Tallahassee, Florida 32306

A completely automated free-field sound-localization apparatus is described along with a behavioral technique that provides several advantages over previously available methods. With the apparatus, the ability to localize the source of a sound has been tested in a wide variety of mammals including cats, rats, squirrel monkeys, hedgehogs, and tree shrews.

To perform a free-field sound-localization task, an animal must sense the direction of a sound source and then make the appropriate sequence of motor responses necessary to indicate it. But because of the neurophysiological importance of requiring an animal to approach the sound source rather than merely to indicate its direction (e.g., Masterton & Diamond, 1973), an apparatus for testing sound localization ability, invented by Neff and his students in the late 1940's, has been used extensively in studies of the central auditory system (cf. Harrison & Beecher, 1969; Neff, Arnott, & Fisher, 1950; Neff, Diamond, Fisher, & Yela, 1956; Strominger & Oesterreich, 1970). Although that apparatus has now served several generations of experimenters, it has shortcomings, all of which stem from the fact that the animals must be handled between trials.

Because an animal's ability to localize the source of a free-field sound has become an important issue in auditory neurophysiology once more (Erulkar, 1972; Masterton, 1974), we have designed a completely automated sound-localization chamber suitable for most laboratory mammals. The dimensions provided in this report are appropriate for animals ranging in size from mice to squirrel monkeys. The device is a semicircular chamber (similar to Neff's) with a "start point" at the center and speakers at the perimeter. Correct localization is rewarded with small amounts of water. The apparatus is reliable, handling of the animals is not required, response requirements are simple, and training is rapid.

APPARATUS CONSTRUCTION

Construction is relatively simple: a semicircular platform with a 48-in. radius is cut from 3/4-in. plywood (see Figure 1). (The large radius is necessary to allow measurements of minimum audible angle which normally requires placement of the speakers within 3-5 deg.) Ten 1-in. x 2-in. framing supports, 18 in. high, are attached around the perimeter of the platform. One-half-in. mesh wire screen is stapled to the frame and covered with double layers of black burlap to form the walls. Wire screen with a hinged 8-in. square door for access into the apparatus also covers the chamber as a

ceiling. Heavy wool blanketing draped over the ceiling and walls and wood chips on the floor help absorb ambient noises and echoes.

A permanent center spout is fitted into a 3/4-in.-diam Plexiglas cylinder pressed through a slightly undersized hole at the center of curvature of the semicircular platform, 16 in. from the rear wall. The height of the spout is adjustable for different sized animals. A triangular stainless steel plate, 10 in. long and 6 in. wide at its base, is located on the floor behind and pointing toward the center spout. This plate provides one side of a drinkometer contact circuit, the spout provides the other. When an animal stands on the floorplate and licks or mouths the spout, the contact circuit is closed and a trial begins.

Two movable goalboxes that can be separated from 5 to 180 deg are constructed from 1/2-in. plywood and black Plexiglas as shown in Figure 2. Each box contains a 2 x 6 in. oval speaker (Quam, 8 ohm) centered 6 in. above the floor. A water spout, which delivers the reward and also serves as one side of another drinkometer circuit, protrudes below the speaker, 2 in. above the floor. To provide the other side of this

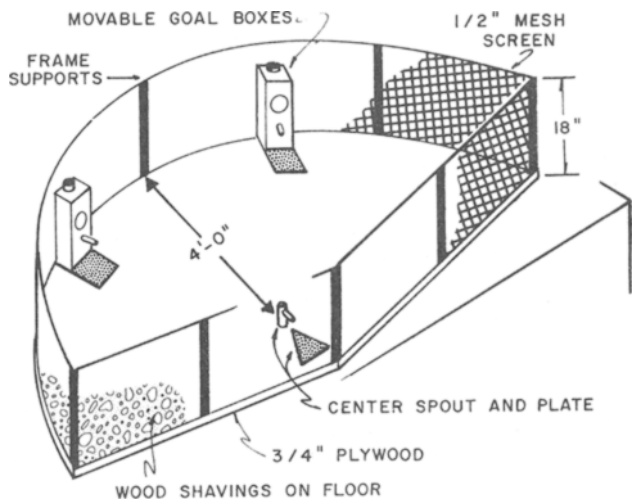

Figure 1. Sound-localization chamber. Thirsty animal begins trial by closing circuit between center spout and plate; ends trial by closing similar circuit at one of two goalboxes.

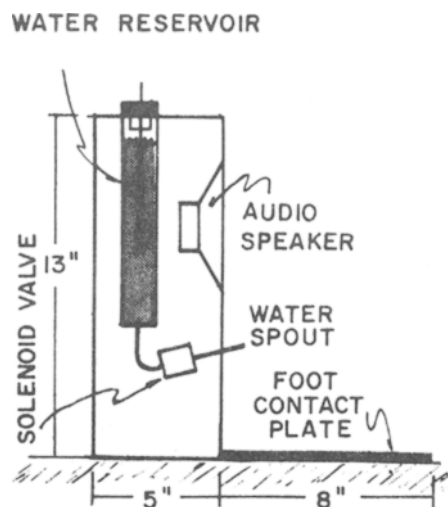

Figure 2. Details of goalbox containing speaker, water-delivery system, and contact-sensing circuit. Animal responds by standing on footplate and licking water spout, closing the contact circuit. If response is to be rewarded, solenoid valve opens for fixed period delivering water. Stopped water reservoir with tube-vent fixes water pressure despite changing water level.

drinkometer circuit, a 6 x 10 in. stainless steel floor plate extends out from each goalbox.

Within the goalbox, a reservoir maintains a constant pressure regardless of water level. Separate water reservoirs in each of the goalboxes are necessary if tap water is used, to prevent cross-talk between the drinkometer circuits (Figure 2). Thus, there are three completely independent drinkometer circuits in all: one at the center spout and one at each of the goalboxes.

The tubing connecting the reservoir to the spout within each goalbox is interrupted by a solenoid-operated water valve (Skinner, C Series, 115 V ac, 5/32-in. orifice diam). To avoid voltage fluctuations in the programming circuits, the solenoid valves have a separate power supply.

The electrical connections for the speaker, the solenoid valve, and the contact circuit are soldered to a Jones socket, countersunk flush with the top of the box. The connecting plug from the programming equipment fits through a hole in the screened ceiling keeping the wires out of the animal's reach.

A conventional programming rack controls stimuli, rewards, and contingencies, and records contacts at either the center or the response spouts.

SOUND EQUIPMENT

White noise, pure tone, or click stimuli are led from their respective generators (Grason-Stadler Model 455C noise generator; Hewlett-Packard Model 200AB audio oscillator, or Tektronix Type 161 pulse generator) to an electronic switch (Grason-Stadler Model 829E). The electronic switch is externally controlled through the

contacts of a relay activated by the animal's closure of the contact circuit at the center spout. The signal is led through a variable bandpass filter (Krohn-Hite Model 3202) to an audio amplifier (McIntosh MC-30) and finally to an attenuator (Hewlett-Packard 350C). The signal is then switched through make-before-break contacts of a relay that determines which box emits the sound and, finally, to a balancing attenuator in series with each speaker (Mallory, T8). Electrical connections are made with two-conductor shielded cable and, where necessary, differing impedances are matched with transformers (Stancor, A-8101, 5W).

The speakers are calibrated and equated with sound-pressure level measurements taken at the center spout. For most purposes, a 1/4-in. condenser microphone (Bruel & Kjaer, Type 4134) connected to a microphone amplifier (B & K, Type 2604) and an octave filter set (B & K, Type 1613) have proved sufficient.

BEHAVIORAL PROCEDURE

A trial is initiated whenever the animal stands on the center footplate and licks or mouths the center spout. By judicious placement of the floorplate, the animal can be made to align its head and ears in any direction desired. The circuit closure at the center spout signals the programmer to present a sound from one of the boxes.

The animal then makes its choice by licking the spout on one of the goalboxes. If the response is correct, the solenoid valve is activated for whatever length of time is necessary to deliver the proper amount of reward. If the choice is incorrect, the animal is forced to begin another trial at the center spout in order to obtain another opportunity for reward.

Training and testing technique

Equal numbers of trials are presented from each box according to a Gellermann sequence. To break position response tendencies before they become engrained, a procedure is used in which only rewarded trials, not responses, are equated. That is, the next step of the Gellermann sequence is reached only after a correct choice. Since an incorrect choice does not advance the Gellermann series, an animal must break a position habit in order to gain reward. Of course, only trials immediately following a correct trial are true tests of sound localization.

Pretraining techniques

The pretraining procedure currently in use has three stages.

Stage 1. (Response spout training)—The animal is 48-h water deprived before being placed in the chamber. Without requiring a response at the center spout, a sound is continuously emitted from one of the boxes until the animal chooses that spout and obtains water. Two seconds later, the sound is again emitted from one

of the two boxes according to the Gellermann series. This cycle repeats itself until a preset number of rewards (usually 40 or more) have been obtained.

Stage 2. (Center spout training)—The following day, the animal is placed in the chamber with a sound emanating from one of the goalboxes. When the animal licks the correct spout, the sound goes off and remains off until the animal contacts the center spout. This response initiates the signal from one of the two boxes again. During this stage, errors are still impossible, in the sense that only contacts with the correct spout have a consequence, terminating the sound and providing reward. This session ends only after a preset number of rewards have been obtained (which now reflect the number of trials initiated and terminated, but provides no information about the first choice of the animal nor its localization ability).

Stage 3. (Contingency training) During Stage 3, the animal can make errors, i.e., after a trial begins by contact with the center lick spout, the first choice determines whether that trial is correct (rewarded) or incorrect. After either event, the animal must contact the center lick spout to begin another trial. In short, further training and testing follows a two-choice noncorrection procedure. From this point on, only stimulus parameters are varied until the animal is localizing the source of the appropriate sound.

Adaptation to different animals

In our research, the total number of rewards given in a session (true localization trials) have varied from 40 for hedgehogs to 200 for squirrel monkeys. The exact number of trials is determined by the size of each reward and the total amount of water the animal drinks daily. Reward size is determined by the amount of water that will support the animal's behavior; .1 ml is large enough for white rats, tree shrews, and hedgehogs, but squirrel monkeys require about .5 ml and cats 1.0 ml.

Because of the necessity to vary easily the amount of water for the different animals, it is advantageous to control duration of valve opening rather than water pressure. A water spout with a small bore diameter (1 mm) tilted slightly upward provides consistency in the amount of water delivered and discourages prolonged sucking. Animals soon learn to touch the spout with an open mouth, collect the spurt of water, and leave it quickly to return to the center spout.

Cats, squirrel monkeys, hedgehogs, tree shrews, and white rats have been successfully trained to localize the source of a variety of different sounds. The only important modification necessary was for cats. Because cats do not easily obtain water from an ordinary drinking spout, small collecting basins are clamped onto the protruding spouts (Figure 3). These devices allow cats to lap the water.

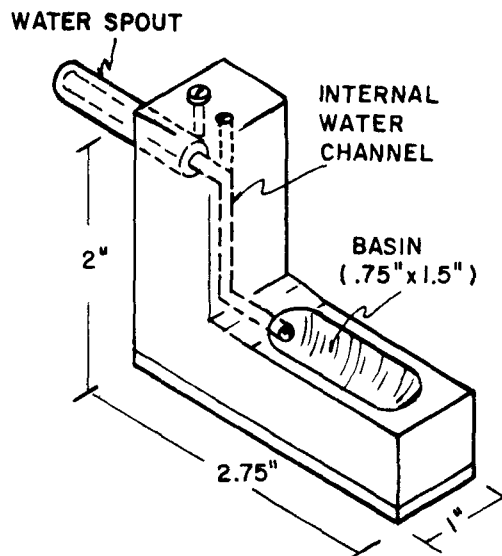

Figure 3. Special water-collecting basin for cats. Solid aluminum block is drilled to fit onto water spouts in goalboxes. Insulated from floorplate, it also serves as one side of contact circuit.

The technique and apparatus described provide fast, sensitive, and rigorous measures of sound-localization ability under a number of conditions. Minimum audible angles can be measured by gradually reducing the angle of separation between the goalboxes; the effects of unilateral lesions in central auditory structures can be determined by placing both goalboxes on one side of the chamber; motor ability can be assessed independently of sensory ability by observing the independent components of the response such as locomotion or orienting and consummatory reactions.

REFERENCES

- Erulkar, S. D. Comparative aspects of spatial localization of sound. *Physiological Reviews*, 1972, 52, 237-360.
- Harrison, J. M., & Beecher, M. D. Control of responding by the location of an auditory stimulus: Role of rise time of the stimulus. *Journal of the Experimental Analysis of Behavior*, 1969, 12, 217-227.
- Masterson, R. B. Adaptations for sound localization in the ear and brainstem of mammals. *Federation Proceedings*, 1974.
- Masterson, B., & Diamond, I. T. Hearing: Central neural mechanisms. In E. Carterette and M. Friedman (Eds.), *Handbook of perception* Vol. III. New York: Academic Press, 1973.
- Neff, W. D., Arnott, G. P., & Fisher, J. F. Function of auditory cortex: Localization of sound in space. *American Journal of Physiology*, 1950, 163, 738.
- Neff, W. D., Diamond, I. T., Fisher, J. F., & Yela, M. Role of auditory cortex in discrimination requiring localization of sound in space. *Journal of Neurophysiology*, 1956, 19, 500-512.
- Strominger, N. L., & Oesterreich, R. E. Localization of sound after section of the brachium of the inferior colliculus. *Journal of Comparative Neurology*, 1970, 138, 1-18.

(Received for publication June 18, 1974;
revision received August 27, 1974.)