

An Economic Analysis of the Self Commitment of Thermal Units

Simon Ede, Ray Zimmerman, Timothy Mount, Robert Thomas, William Schulze
Cornell University

sme11@cornell.edu, rz10@cornell.edu, tdm2@cornell.edu, rjt1@cornell.edu, wds3@cornell.edu

Abstract

Given the load profile of an electricity market and the capabilities of the set of generators supplying power to that market, it is likely that at any given point in time, available supply will exceed demand. If only a subset of generators is required, some method is required to commit and de-commit generators. In the past, system operators have employed a centralized method of unit commitment. Deregulation of the electricity industry throws doubt on the continued suitability of this method due to fairness issues and availability of accurate cost data. This paper will examine the performance of decentralized unit commitment, where dispatch of generators is determined by offer curves submitted into a spot market by power producers.

This paper will first discuss, the objectives of centralized unit commitment. Doubt is cast upon the continued efficiency of centralized dispatch in the presence of asymmetric information in deregulated markets. The second section of this article will describe the properties of an auction mechanism that is being applied in electricity spot markets to determine dispatch. In the third part of the discussion, we will examine the impact of quasi-fixed costs, such as start-up costs, upon the offer strategies of generators in such auctions and their impact upon the cost efficiency of dispatch. The paper will conclude with empirical evidence gathered from a series of economic experiments conducted at Cornell University's Laboratory for Experimental Economics and Decision Research, using a computer based simulation of a real transmission network.

1. Introduction

In regulated or state monopoly power markets, a central system operator made the decision which subset of generators should be operating at any particular point in time. That system operator had access to all relevant information such as heat rate curves, minimum up and down times, start-up costs and other such system and operating constraints. Provided that the information available to the system operator was accurate, it was possible to dispatch generators so as to minimize system-operating costs, consistent with generator and network constraints.

Liberalization of energy markets worldwide has led not only to the privatization of generation and network assets but also of information. Previously, the information would have been either common knowledge or obtainable by mandate. If the efficiency of dispatch depends on the accuracy of the information available to the dispatcher, then efficiency of centralized dispatch in a deregulated market depends upon the willingness of power producers to accurately reveal their cost structures.

2. Centralized Unit Commitment

In the most conventional form of economic dispatch, the problem facing the system operator was to minimize total operating costs such that total generation was equal to total load. This is shown below in an example of a market in which generating units may be turned on or off but there are no start-up costs or minimum up or down times.¹ Throughout this paper, it shall be assumed that capacity is offered into the market in blocks at a single price per block. Where multiple blocks are offered, the resulting offer curve would be a step function.

The aim of the system operator is:

$$(1) \quad \min_{u, q_g} \sum_{i=1}^{n_g} u_i C_i(q_{gi})$$

subject to

$$(2) \quad \sum_{i=1}^{n_g} u_i q_{gi} = Q_d$$

where:

¹ The following model follows that developed by Marija Illic and Frank Galiana in "Power Systems Restructuring: Engineering and Economics" Eds. Illic, Galiana, Fink, 1998.

- u_i = 0,1 = on-off state of generator i.
 $C_i(q_{gi})$ = cost function of generator i
 q_{gi} = units of power produced by generator i.
 Q_d = demand for load.
 n_g = number of generators in generation set.

The following lagrangian can be formed:

$$(3) \quad L(u_i, q_i, \lambda) = \sum_{i=1}^{n_g} u_i C_i(q_{gi}) - \lambda \left[Q_d - \sum_{i=1}^{n_g} u_i q_{gi} \right]$$

The first order conditions of (3) solve to and require:

$$(4) \quad \frac{dC_i}{dq_{gi}} = \lambda, \forall i$$

λ is the effect upon (1) of relaxing constraint (2) by one unit. As such this is the marginal cost to the whole system of producing one more unit of power. At the optimum all generators will produce q_{gi} such that their marginal costs are equal to λ .

Generation is therefore a function of λ . i.e.

$$(5) \quad q_{gi} = q_{gi}(\lambda)$$

This can be substituted into (3) and the subsequent lagrangian will be:

$$(6) \quad L(u_i, \lambda) = \sum_{i=1}^{n_g} u_i C_i(q_{gi}(\lambda)) - \lambda \left[Q_d - \sum_{i=1}^{n_g} u_i q_{gi}(\lambda) \right]$$

If (6) is minimized with respect to u_i , it is possible to derive the "Switching Law":

$$(7) \quad u_i = \begin{cases} 0 & \text{if } C_i(\cdot) - \lambda q_{gi} > 0 \\ 1 & \text{if } C_i(\cdot) - \lambda q_{gi} < 0 \end{cases}$$

In other words, only those generators whose average cost is less than the system marginal cost will be dispatched in any given period. Adding network and generator constraints can easily complicate this simple model but its basic reliance upon symmetric information should be easily evident. The central system operator needs power producers to accurately reveal $C_i(q_{gi})$ to determine u_i correctly. Any deviation could lead to an inefficient dispatch of generators.

In the simplified model, with many competitors, there is little apparent incentive to reveal inaccurate cost

curves. With ramping constraints, quasi-fixed costs and network constraints, the situation is more complicated. It is important to ensure that the problem of unit commitment is solved equitably. Unit commitment algorithms can frequently produce more than one efficient dispatch schedule. Which schedule would be appropriate?

Under some form of common ownership, operating rights can be shared equitably through the system. Under decentralized control it is less clear. As a result, spot markets have been used to resolve the inherent difficulties in solving the unit commitment problem.

3. Decentralized Unit Commitment

Suppose that the decision rule that determines the dispatch schedule is changed so that unit commitment is determined by the interaction of offer curves submitted into a spot market, subject only to network constraints. Can an auction lead to efficient dispatch in the same way as a central system operator with perfect information? Alternatively, can generators internalize their constraints into a single offer curve? This is self-commitment.

McAfee and McMillan [1] define an auction to be a market institution with an explicit set of rules which is used to determine the allocation of a resource and its price depending on the offers and bids of the participants in the market. If this definition of an auction is applied then the role of the system operator is reduced to adjusting the spot market outcome, in an equitable manner, to satisfy network constraints.

One possible auction format for the deregulated electricity market is a variation on a first price sealed bid auction. In this auction format, generators submit offer curves for their capacity which represent the minimum price at which they would be willing to operate that generating capacity. The auction determines dispatch on an hourly or half-hourly basis. Generators know the result of the previous auction before they submit their offer curves for the next auction. Oren and Elmaghraby classify this as an "Hourly Supply Curve Vertical Auction" [2]. The system operator then ranks the offers from cheapest to most expensive and then dispatches the generators in order of cost, subject to network constraints, until demand for load has been satisfied. All generating units are then paid a uniform price that represents the offer of the last unit of capacity to be dispatched. This is referred to as a "uniform price auction".

It has been demonstrated using computer based economic experiments that in this kind of auction where there are no network or generator constraints, offers will approximate marginal cost curves when the number of market participants is six or greater [3], [4]. This can be shown by developing the model above further.

The spot market re-forms equation (7) by substituting $O_i(q_{gi})$ for $C(q_{gi})$ into (1), where $O_i(q_{gi})$ is the offer curve submitted to the system operator by generator i . This leads to the following results:

$$(8) \quad \frac{dO_i}{dq_{gi}} = \lambda \text{ and}$$

$$(9) \quad u_i = \begin{cases} 0 & \text{if } O_i(\cdot) - \lambda q_{gi} > 0 \\ 1 & \text{if } O_i(\cdot) - \lambda q_{gi} < 0 \end{cases}$$

Unless $O_i = C_i$, dispatch will be different. They will be different only when there is an incentive to deviate.

In a world without network and generator constraints with many competitors, a rational generator will seek to maximize profits.

$$(10) \quad \max_{q_i} \Pi(q_{gi})$$

where,

$$(11) \quad \Pi(q_{gi}) = pq_{gi} - C_i(q_{gi})$$

where,

p = uniform price
 Π = profit function

Where the number of competitors is large and the price converges to a single electricity price for buyers and sellers, p , it is possible to maximize profit to give:

$$(12) \quad \frac{dC_i}{dq_{gi}} = p, \forall i=1, \dots, n_g$$

We know intuitively that a generator would not wish to operate if the return from doing so is negative. This implies:

$$(13) \quad p > \frac{C_i}{q_{gi}}$$

If the generator applies this rule to determine offers, it will only be turned on if it meets the same average cost rule, developed in equations (1)-(7). Therefore, if

competition prevails, dispatch is likely in the absence of network constraints, to produce the cost efficient dispatch schedule.

Network constraints can cause generators to submit offers in excess of their cost curves not only in they are affected by the constraint but also by a cascading effect through the rest of the system [5]. The remainder of this paper will demonstrate the effect of quasi-fixed costs such as start-up costs.

4. The Impact of Quasi-Fixed Costs

Oren and Elmaghraby [2] suggest that start-up and other such quasi-fixed costs can distort the efficiency of dispatch by providing inefficient generators an incentive to undercut the offers of more efficient generators and sneak into the dispatch schedule.

The inter-temporal dependencies caused by start-up costs provide an incentive to accept losses or reduced profits in one period in order to increase profits overall. In a simple two period model, this might imply submitting an offer below cost, losing money, in order to avoid the greater cost of paying for start-up costs in the next period. Each and every generator must determine whether it should operate continually or cycle on and off with the peaks and troughs in demand. In an intensely competitive market, the optimal strategy will be one that leaves the generator at worst indifferent between the cycling and continual operation. In a repeated game, this strategy can be determined by use of backward induction. This can be generalized as follows for a simple two period game, where period 1 has low demand and period 2 has high demand:

Suppose:

A_i = set of actions available to generator i ,
 $a_{it} \in A_i$ = action available to generator i in period t
 $t = 1, 2$
 $u_i(A_i, A_j) =$ payoff function to generator i , $i \neq j$

Looking forward, each generator will estimate the set of possible outcomes in the high periods and then select the action in the high period which will maximize the expected payoff in that period. The pay-off function to generator i can, therefore, be re-characterized as:

$$(18) \quad u_i = u_i(a_{i1}, a_{j1}, a_{i2}^*, a_{j2}^*)$$

Where,

a_{i2}^* = payoff maximizing action in period 2 for i.
 a_{j2}^* = payoff maximizing action in period 2 for j.

Given this understanding of the necessary actions in the high period it should be then possible to select the optimal action in the low demand period a_{i1}^* and a_{j1}^* . i.e.

$$(19) \quad u_i^* = u_i(a_{i1}^*(a_{i2}^*, a_{j2}^*), a_{j1}^*(a_{i2}^*, a_{j2}^*))$$

Where u_i^* is the optimal payoff to generator i given that generator j adopts its best strategy which is similarly determined.

This can be shown through a simple two stage profit maximization process, based again on the high-low period model of demand. Let us assume that the demand for electricity can be broken into two periods, low and high demand and that this schedule repeats itself through time.

Let:

k = time period [1=low, 2=high]
 i = generator
 p_{ti} = price received in period t by generator i
 q_{ti} = quantity of electricity sold by generator i in period t
 Π_{ti} = profit to generator i in period t
 c_i = marginal cost of production for generator i
 S_i = start-up cost for generator i

Using the logic of backward induction, generator i, in period 1 will form an expectation of the payoffs available to it in period 2.

If

$$(20) \quad \Pi_{2i} = -\min[c_{1i}q_{1i} - p_{1i}q_{1i}, S_i] + p_{2i}q_{2i} - c_i q_{2i}$$

$$\forall q_{1i} > 0$$

Maximization of profits in period 2 is inter-temporally dependent upon decisions made in period 1. The first term is the debit received from its operations in period 1. If the generator decided not to enter the auction in period one, then the first term will collapse to S_i . This will be the start-up cost incurred in period two should the generator decide to enter the auction. If the generator did enter the auction in the low period but was not dispatched then the term will also collapse to S_i . If the generator was dispatched in period 1 then the first term will be equal to the loss incurred in period 1. We assume

that the generator would not wish to enter the auction in the low period unless the profit or loss incurred is less than or equal to the start-up cost incurred in the next period due to non-dispatch.

Knowing this, the generator can decide upon its optimal low load period strategy. The choice essentially boils down to whether the generator attempts to run in low periods even though it may incur a loss in that period (as this would increase aggregate profits over both periods) Using the above model again, it is possible to develop a rule of thumb for an optimal strategy.

We will consider two separate strategies. Firstly we examine the optimal strategy of a generator which is currently operating. Secondly, we will consider the strategy of an idle generator.

A generator that is currently dispatched should find it optimal to remain operating in low demand periods, if and only if it incurs a loss less than or equal to that which would be incurred in start-up costs in the high demand period. i.e.

$$(21) \quad \int_{q_i=0}^{q_{\min}} \frac{dTC_i}{dq_i} dq_i - p_{1i}q_{1i} \leq S_i$$

Where:

TC_i = total cost of generator i
 q_{\min} = minimum generation required to operate

If the generator is to be turned on it must produce q_{\min} . This is the key threshold for the generator. Offer strategy will differ for $q < q_{\min}$ and $q > q_{\min}$. For $q > q_{\min}$, generation has been ensured and there is no need to further consider the impact upon the next period. Above q_{\min} , therefore, offers in a competitive market should revert to simple marginal cost pricing.

The above equation can be simplified to:

$$(22) \quad TC(q_{\min}) - S_i \leq p_{1i}q_{\min}$$

or

$$(23) \quad p_{1i} \geq AC(q_{\min}) - \frac{S_i}{q_{\min}}, \forall q < q_{\min}$$

$$p_{1i} = c_i, \forall q > q_{\min},$$

It is important to note that the generator's optimal strategy returns to marginal cost pricing for all units

greater than q_{\min} . Once dispatch has been achieved, there should be no further need to incur losses.

This can be generalized to a game of T periods, in which generators form expectations as to when the next high demand, or profit making period, will occur. Let:

T = Expected number of periods until the next high demand period.

Equation (21) can now be amended to:

$$(24) \quad \sum_{t=0}^{T-1} \int_{q_i=0}^{q_{\min}} \frac{dTC}{dq} dq - \sum_{t=0}^{T-1} p_{ti} q_{ti} \leq S_i$$

Given the invariability of costs between adjacent periods, (24) can be simplified to:

$$(25) \quad \bar{p}_i = AC(q_{\min}) - \frac{S_i}{Tq_{\min}}, \quad \forall q < q_{\min}$$

where \bar{p}_i is the average price.

Equation (25) in itself does not really provide much information. It shows, however, that in multi-period games, generators who assess there to be a motive to remain dispatched, even in low demand periods, will need to carefully balance their offer strategies. One particular case of (25) allows us to draw up a few rules of thumb.

Suppose that in period $t=0$, demand is at its lowest and in order to be dispatched, generator i must submit its lowest possible offer. Equation (23) provides that offer. If we substitute that result into equation (25) we can derive an interesting result for all T-1 periods.

$$(26) \quad \frac{AC(q_{\min}) - \frac{S_i}{q_{\min}} + \sum_{t=1}^{T-1} p_{ti}}{T} \geq AC - \frac{S_i}{Tq_{\min}}$$

$$(27) \quad \sum_{t=1}^{T-1} p_{ti} = AC(T-1)$$

Equation (27) implies that if a minimum offer is required in one period, then the average offer price for all other periods leading up to the next high demand period should equal the average cost of running q_{\min} units of capacity. For all units of capacity greater than q_{\min} , the same strategy of marginal cost pricing applies.

This establishes an important rule. If the expected average price of electricity in shoulder periods (i.e. other than lowest demand periods) is less than average cost, then the generator should not attempt to remain dispatched in between high demand periods. This will avoid the worse case scenario of incurring losses for remaining dispatched and also incurring start-up costs.

The final element to consider in the offer strategy of generators is to decide what the appropriate offer strategy should be in high demand periods. There are two basic scenarios to consider which have alternative answers.

Firstly, if the generator was able to pursue a schedule of continuous operation, the costs of operating are entirely fixed. Being sunk costs, they should not enter consideration for the marginal pricing decision.

If, however, the generator has been cycling on and off between high and low load periods, then the start-up cost is not a deadweight cost. It can be avoided by not operating in the high demand period. In this case, logic predicts that the generator will not wish to be dispatched in the high demand period unless it breaks even. Since the high demand period, is in essence the profit making period, if profit cannot be made in it, it should not operate at all.

This is demonstrated below for the simple two period low-high demand period:

$$(29) \quad p_i q_{\min} - TC(q_{\min}) \geq S_i$$

which implies:

$$(30) \quad p_i \geq AC_i(q_{\min}) + \frac{S_i}{q_{\min}}, \quad \forall q < q_{\min}$$

$$(31) \quad p_i = \frac{dC_i}{dq_i}, \quad \forall q > q_{\min}$$

Equation (30) is the reverse of equation (23). The generator will de-commit itself unless it can be guaranteed to make a profit. It is possible to generalize (30) further. If A is the number of periods the generator expects to remain operating, the pricing rule can be determined in the following way:

$$(32) \quad \sum_{a=0}^{A-1} p_{ai} q_{\min} - \sum_{a=0}^{A-1} TC_{ai}(q_{\min}) \geq S_i$$

Which can be solved as:

$$(33) \quad \bar{p}_i \geq AC_i(q_{\min}) + \frac{S_i}{Aq_{\min}}$$

Again, once the generator has ensured dispatch, it can revert to marginal cost pricing on additional units dispatched above q_{\min} .

Those generators that expect to be on for an indefinite amount of time, i.e. where A is very large, will only need to submit offers in excess of average cost. This is the same result as one would expect from a generator currently operating where start-up costs are sunk costs. Only generators that expect to be dispatched periodically are bound by (33) to offer capacity above cost.

Using backward induction, the following conclusions can be drawn. A generator will not commit itself to operation in the low periods of demand unless it be sure that it will be able to break even over the complete cycle of demand. Those generators, therefore, which do operate in low demand periods should need only to submit offers in high demand periods of c_i (for the capacity up to and including q_{\min}). All other generators will choose to de-commit themselves in the low demand periods and follow (33) in high demand periods.

In the real world it is difficult to separate the effects of start-up costs from the noise from other factors. The Cornell University Laboratory on Economics and Decision Research (LEEDR) has, consequently conducted a series of economic experiments using an Internet based simulation of an electricity market, known as PowerWeb [6] to assess how power producers would react to the existence of start-up costs.

5. Rationale for Experiments

Davis and Holt identify two advantages to laboratory methods [7]. Firstly, the experiments and results are replicable and so it is possible to verify the findings independently. Most information in the electricity market is private and very proprietary, consequently it is difficult to gather sufficient information to verify conclusions.

Secondly, laboratory conditions can be set to control for extraneous circumstances which would be difficult to avoid and hard to mitigate in the real world. This can allow the researcher to eliminate the "noise" and concentrate upon the theory or policy which needs to be examined.

A cause of concern is the selection of subjects for the experiments and their similarity to the real world decision makers. Experiments conducted at LEEDR have shown that in these electrical power experiments that a student pool of subjects performed in a similar manner to trained electricity industry professionals [5]. There is the added qualitative advantage to using an "inexperienced" subjects that, should those subjects confirm the validity of the theory, then it is more than likely that experienced decision makers will even more easily make the same decisions. Indeed, the difference in behavior, in experiments to test for market power, between the students and the professionals was the speed with which the subjects figured out that they had the ability to raise prices above marginal costs.

In reality that the laboratory experiments simplify what is a complicated market. Conducted properly, however, they can allow for an assessment of the comparative statics of our theory of behavior.

6. The Experiments

In the research conducted, student subjects were recruited to participate in computerized experiments under controlled conditions at LEEDR. Students were paid at the end of the experiments, based on their performance in relation to the other subjects.

Students recruited for this experiment were business and economics students at Cornell University. The majority of students were sophomore through seniors who had taken or were currently enrolled in intermediate microeconomics and/or a senior level class in price analysis. One additional group was recruited from graduate economics students at Cornell. Few of the students have previously participated in an economic experiment and were not allowed to participate more than once. Students were told that the experiments would last about two hours and were asked to remain until all the subject experiments had been completed.

Groups of six subject generators were used in the experiments in order to minimize any potential for generators to exact market power.

Each subject was assigned to one generator, the cost parameters of which were selected to mimic three typical level of costs for electrical power generation: baseload, mid-level and peaking. The cost structure is shown in the tables 1 and 2.

Generator	Variable Costs					
	Block 1		Block 2		Block 3	
	MW	Cost (\$)	MW	Cost (\$)	MW	Cost (\$)
1	10	23	25	30	25	35
2	10	23	25	30	25	35
3	20	18	30	18	10	40
4	20	20	20	30	20	40
5	20	20	20	30	20	40
6	20	15	30	15	10	40

Table 1. Generator Variable Costs

Generator	Type	Start-Up Cost (\$)
1	Peaking	50
2	Peaking	50
3	Baseload	500
4	Mid-Level	150
5	Mid-Level	150
6	Baseload	500

Table 2 Start-Up Costs

A vertical hourly uniform price auction was employed in which generators submitted an offer price for each of its three blocks of capacity in each trading period. Generators discovered the results of that auction before submitting offers for the next auction. Demand in the market was held to be perfectly inelastic. It varied from approximately 200MW in high demand periods to 100MW in low demand periods. (The simulated network was allowed to experience transmission losses but to an extent which only marginally affected locational prices.)

Figure 1, which is shown below, shows the network through which the generators are linked to the demand for load. It is a thirty bus system. For the purposes of these experiments, the network was unconstrained by transmission constraints but subject to transmission losses.

Subjects were informed through an instruction sheet and a brief presentation by the experiment leader of the rules of the game including the reservation price for the experiment, the number of other generators and for how many rounds the experiment would last. They were informed that the level of demand alternated between high and low demand periods. They were informed of their own cost structures but not those of their competitors and that these costs would not vary during the experiment. Subjects were also not aware of the capacities of their competitors. Subjects were also given a brief tutorial to show how start-up costs applied and how to calculate profits given start-up and variable costs.

² This was intended to reinforce the rules of the game and ensure that subjects began with an equal understanding of the auction process.

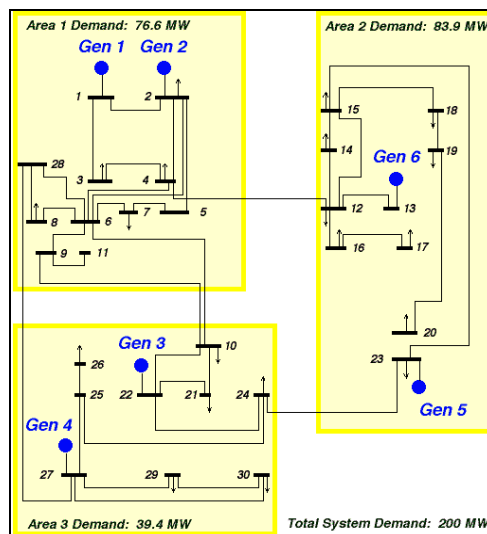

Figure 1. System Diagram

Throughout the experiment, offers remained private. The final price in each trading period was reported to subjects after each auction period. Subjects were informed of how much capacity in each of their three blocks were sold. Subjects did not know how much other generators sold. The number of generators meant that it would be impossible for any one generator to guess which generators has sold capacity and how much.

An auction was held for each of the trading periods. The last accepted offer version of the uniform price auction was applied for each of the 50 trading periods.

7. Results

Author's Note: At time of writing, the majority of experiments were still in progress. This section reflects only the results of one group of graduate students.

The results from the experiments appear to validate the conclusions of the theory proposed in this paper. Table 3 shows for each generator the low period offer strategy derived from the theory outlined above.

² A copy of the set of instructions and tutorial used in the experiments are available upon request from the authors.

	Block 1		Block 2		Block 3	
	Cost (\$)	Offer (\$)	Cost (\$)	Offer (\$)	Cost (\$)	Offer (\$)
1	23	18	30	30	35	35
2	23	18	30	30	35	35
3	18	-7	18	18	40	40
4	20	12.5	30	30	40	40
5	20	12.5	30	30	40	40
6	15	-10	15	15	40	40

Table 3. Optimal Offers

Table 9 shows the comparison between optimal offers and those actually observed in the experiments. The actual offer is calculated through a regression of the following format:

$$(28) \quad Offer_{ib} = Constant + \beta_{ib} High$$

High is a dummy variable that takes the value of one in high demand periods and zero in low demand periods. Regressions were conducted on each of the generator blocks, b=1,2,3. Of interest is the constant that should reflect the offer price for the generator in the low demand period. Table 9 shows the low demand period offers for each of the generators i=1,...,6 for each of the blocks of capacity for which offers were submitted.

Table 4 shows that in general, offers in the low period were marginal cost and lower. Of most interest is the competition between generators 1,2 and 4,5. If generators 1,2 submit their first block at lowest possible offer and generators 4,5 priced their first block at marginal cost, then generators 1,2 could have been dispatched and unit commitment would have produced a cost inefficient outcome. As predicted in the theory outlined above, generators 4,5 were able to anticipate this and both submitted at the optimal lowest possible offer. The end result was that generators 1,2 generally cycled on and off between high and low periods.

The baseload generators could be displaced in the low load periods only by an irrationally low bid and so faced few incentives to submit offers below marginal costs. In these experiments the baseload generators tended to offer at marginal cost. Nevertheless, profits were reduced by this failure to cut offers. Generator 6 in particular failed to dispatch as much capacity as it should have done.

As a note, the experiment did permit the generators to submit negative offers. Subjects were informed that any offer less than the reservation price was acceptable.

The marginal cost curves of each generator were sufficient to guarantee at least break-even at marginal

cost should the generator submit the last accepted offer in the high period. In this scenario the optimal offer to submit would be marginal cost. Table 5, below, shows a comparison between optimal high period offer and actual observed offers. Observed offers were calculated using equation (28).

	Block 1		Block 2		Block 3	
	Optimal Offer (\$)	Actual Offer (\$)	Optimal Offer (\$)	Actual Offer (\$)	Optimal Offer (\$)	Actual Offer (\$)
1	18.00	15.90	30.00	28.89	35.00	40.20
2	18.00	18.21	30.00	30	35.00	35.00
3	-7.00	16.35	18.00	18.47	40.00	39.00
4	12.50	12.50	30.00	30	40.00	40.00
5	12.50	12.39	30.00	30.03	40.00	40.11
6	-10.00	15.46	15.00	16.79	40.00	44.20

Table 4. Low Demand Period Comparison

	Block 1		Block 2		Block 3	
	Optimal Offer (\$)	Actual Offer (\$)	Optimal Offer (\$)	Actual Offer (\$)	Optimal Offer (\$)	Actual Offer (\$)
1	23	7.75	30	29.375	35	41.25
2	23	23.00	30	30.25	35	35.00
3	18	17.00	18	22.60	40	40.20
4	20	12.50	30	30.00	40	40.00
5	20	12.38	30	30.09	40	40.10
6	15	16.20	15	22.05	40	44.48

Table 5. High Demand Period Comparison

The results from the high period are more mixed than for the low demand periods. Both baseload generators 3,6 offered significantly above cost on their second block. This can probably be explained by the fact that they were not the system marginal units. Those generators who had the potential for possessing the system marginal unit in their second blocks, generators 1,2,4,5, offered at marginal cost. As would be expected, where the incentives to compete exist, behavior follows the predictions of the theory in this paper.

A side effect of the offer strategies under self commitment is an increase in the price volatility. Where discounting in low demand period offers occurs, the differential between prices in the two periods has increased.

The auction process appears to be cost efficient. The results from the auction trading periods are compared to the outcome if all generators submitted marginal cost offers on their capacity blocks. Figure 2 below shows the cost efficiency of dispatch over the experiments for the experiments run. There are 20 data points, each representing a pair of high and low trading periods. Of interest are the latter periods, after a period of

experimentation and acclimatization to the market, efficiencies reach nearly 100%. The vertical hourly supply curve auction is able to produce a cost efficient outcome. Generators were successful in internalizing the impact of start-up costs upon optimal dispatch.

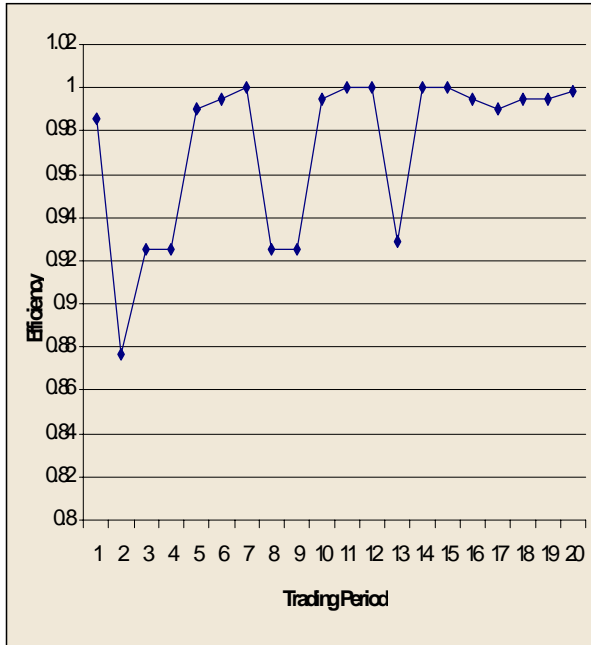

Figure 2. Auction Efficiencies

8. Conclusions

Theory and experimental evidence show that in the absence of network constraints, a spot market employing the last accepted offer version of a uniform price auction can produce a cost efficient dispatch of generators. The role of the independent system operator can be reduced to facilitator of transactions and supervisor of system security and reliability.

This is, of course, a vastly simplified version of the real world market. The experiments, however, help us to determine the relationship between self-commitment and the offer strategies of generators, holding other factors such as networks and existence of market power constant.

The last accepted offer auction is a reasonably simple auction mechanism to administer and its robustness to the existence of start-up costs is reassuring. Further research will be needed to determine whether other auction mechanisms can improve upon the efficiencies shown above.

This conclusion relies on the ability of generators to realize that the problem at hand is not unit commitment but rather unit de-commitment. If generators are able to establish accurately whether they ought to be running or not then dispatch should be efficient. Start-up costs and the ability of generators to offer below cost, force generators to assess this question. Given the inverse relationship between variable costs and start-up costs and the optimal strategies outlined in the previous sections, those generators with high start-up costs should be able to maintain continuous dispatch. Those generators with high variable but low start-up costs will find themselves cycling on and off. This produces the same result as the situation where a central system operator decides dispatch based on accurate cost information.

LEEDR now plans to extend the scope of the experiments to examine the impact of start-up costs in the presence of network constraints. The results of this will be the subject of a future paper.

12. References

- [1] R. Preston and J. McMillan, "Auctions and Bidding", *Journal of Economic Literature*, 15, 1987, pp. 699-738.
- [2] W. Elmaghraby and S. Oren, "The Efficiency of Multi-Unit Electricity Auctions", *PSERC*, 97-15, 1997.
- [2] R.E. Bohn, M.C. Caramanis and F.C. Schweppe, "Optimal Pricing in Electrical Networks Over Space and Time", *Rand Journal of Economics*, 15(3), 1984, pp.360-376.
- [3] R. Zimmerman, R. Thomas, D. Gan, C. Murillo-Sanchez, "An Internet-Based Platform for Testing Generation Scheduling Auctions", *Proceedings of the Hawaii International Conference on System Sciences*, 1997.
- [4] J. Bernard, R. Ethier, T. Mount, W. Schulze, R. Zimmerman, D. Gan, C. Murillo Sanchez, R. Thomas, R. Schuler, "Markets for Electric Power: Experimental Results For Alternative Auction Institutions", *Proceedings of the Hawaii International Conference on System Sciences*, 1998.
- [5] R Ethier, R Zimmerman, J.C. Bernard, R.J. Thomas, W. Schulze, "Energy Auctions and Market Power: An Experimental Examination", *Proceedings of the Hawaii International Conference on System Sciences*, 1999.

- [6] J. Bernard, T. Mount, W. Schulze, R. Zimmerman, R. Thomas, R. Schuler, "Alternative Auction Institutions for Purchasing Electric Power: An Experimental Examination", *Bulk Power System Dynamic and Control IV - Restructuring*, Santorini, Greece, 1998.
- [7] D.D. Holt and C.A. Holt, *Experimental Economics*, Princeton University Press, 1993.
- [8] W. Vickrey, "Counterspeculation, Auctions and Competitive Sealed Tenders", *Journal of Finance*, 16, 1961, pp. 8-37
- [9] W. Vickrey, "Auctions, Markets and Optimal Allocation" in *Bidding and Auctioning for Procurement and Allocation*, Ed. Ahimud, New York University Press, 1976.
- [10] C.A. Holt, "Competitive Bidding for Contracts under Alternative Auction Procedures", *Journal of Political Economy*, 88(3), 1980.
- [11] P.R. Milgrom and R.J. Weber, "A Theory of Auctions and Competitive Bidding", *Econometrica*, 50(5), pp.1089-1122.
- [12] A. Dixit and B. Nalebuff, *Thinking Strategically: The Competitive Edge in Business, Politics, and Everyday Life*, Norton, 1993.
- [13] M. Illic, F. Galiana, L. Fink, *Power Systems Restructuring: Engineering and Economics*, Kluwer, 1998.
- [14] R. Wilson, "The Auction of Shares", *Quarterly Journal of Economics*, 93(4), pp. 675-689, 1979.
- [15] N. von der Fehr and D Harbord, "Spot Market Competition in the UK Electricity Industry", *The Economic Journal*, 103, pp. 531-546, 1993.
- [16] R.H. Patrick and F.A. Wolak, "The Impact of Market Rules and Market Structure on the Price Determination Process in the England and Wales Electricity Market", *POWER Working Paper*, PWP-047, University of California at Berkeley, 1997.