

# An efficient design of primary sedimentation tanks using a combination of response surface, metaheuristic and scenario building

M. Zamani, A. Montazeri, M. Gheibi, A. Fathollahi, K. Behzadian

## Abstract

Solid particle sedimentation is assumed as a complex procedure in both water and wastewater treatment plants. There is a great deal of interest in applying and developing different simulation and optimization methods to design a primary sedimentation tanks (PSTs). In traditional techniques, mechanical and physical parameters are set by sequential error loops. To eliminate the disadvantage of existing techniques, this study proposes a hybrid method based on the response surface methodology, efficient metaheuristics and scenario building methods using different experimental methods. This novel framework creates a robust and sustainable design for the PSTs. First of all, the parameters of the considered PST based on the economic, improve process and tank efficiency scenarios are tuned and optimized by the Central Composition Design (CCD) and Response Surface Methodology (RSM). To forecast an efficient response value for these scenarios, different metaheuristic algorithms including the Genetic Algorithm (GA), Pattern Search Algorithm (PSA) and Simulate Annealing Algorithm (SAA) are applied. Results demonstrated that PSA, GA and PSA with 0.02, 0.032 and 0.063 in comparison with experimental practices have the best calibration for prediction of response in economic, improve process and tank efficiency scenarios, correspondingly. Finally, experimental tests have proven that the optimum Retention Time (RT) is equal to 2 hours based on the biological oxygen demand and the total suspended solids eliminations in the lab-scale setup.

**Keywords:** Primary Sedimentation Tanks, Response Surface Methodology, Metaheuristic Algorithms, Scenario Building Methods.

## 1. Introduction

Recent technologies on wastewater treatment and new designing methods of effluent recycling have a magnificent influence on people's future lives. This significant influence comes from the importance of the recovered water as a new-possible supply of resource. Water and wastewater treatment have been named "the greatest challenge of the 21st century". Consequently, this claim supports and proves the points mentioned earlier (Mujeriego and Asano, 1999; Jover-Smet et al., 2017; ShahrokhiMahdi et al., 2012). Wastewater treatment contains some methods like physical, chemical, and biological treatments. Physical decontamination is one of the most crucial parts of the wastewater treatment process because it will reduce much pollution of the water such as Suspended Solids (SS) and hydro soluble chemicals. Moreover, it increases the efficiency of the treatment by working well during the process (Jover-Smet et al., 2017; ShahrokhiMahdi et al., 2012; Sher et al., 2020; Polorigni et al., 2021; Athanasia et al., 2008). Primary Sedimentation is the first, influential, and actual physical treatment process because of gravity, which extensively applies in water and wastewater physical treatment (ShahrokhiMahdi et al., 2012). These pollutants (SS & hydro soluble chemicals) are the main components of the wastewater and can be found in large portions. The tremendous direct or indirect influence of these contaminations on the living of organisms by bio magnification is undeniable (Sher et al., 2020).

41 Primary sedimentation is included by some complicated physical processes that separate solid and  
42 liquid pollutants, making a separable solution in Primary Sedimentation Tanks (PSTs). Hence, introducing  
43 models which can precisely describe this manner has been one of the most significant and most challenging  
44 problems during recent researches (Polorigni et al., 2021). PSTs contain turbulence flow fields that  
45 influence the efficiency of the process. therefore, some particles that have been settled during the process  
46 may go into a re-suspension procedure, which wastes the past attempts, if the turbulence does not  
47 prognosticate before the turbulence's beginning (ShahrokhiMahdi et al., 2012). Many factors like tank's  
48 class, solid elimination mechanism, loading degree, etc., will influence the efficiency and capability of a  
49 PST. Consequently, recent designers, for example, are trying to oversize the PSTs as a respondent to poor  
50 design, which is the leading cause of system disorders and turbulences (Athanasia et al., 2008).

51 As an acknowledgment to demonstrate the significance of this research in the literature, there have been  
52 many associated and essential records reviewed as follows. Sedimentation of SS in a solution owing to the  
53 gravitational primary sedimentation process has been an essential topic for decades. Since Stokes, 1851  
54 expressed an equalization to demonstrate the activity rate of sedimentation of SS under the sheet-laminar  
55 flow position (Bustos et al., 1999; Jover-Smet et al., 2017). A scientific approach was manifested in the  
56 1970s, striving to ally presentations on sedimentation of dispersed and flocculating suspensions  
57 (ShahrokhiMahdi et al., 2012; Concha et al., 2002). Hazen,1904 observed the opening exposition of  
58 circumstances that affected the sedimentation of dense, hard scraps and introduced the outside charging  
59 theory (Concha et al., 2002). An active approach of sedimentation arises from concentration changes valid  
60 for theoretical suspensions was encountered by Kynch in 1952 (Athanasia et al., 2008; Concha et al., 2002).  
61 Christoulas et al., in 1998, developed an experimental design for the primary sedimentation process. This  
62 model gives a good result in the model's efficiency while testing under the combined analysis of three well-  
63 correlated sets of data (Christoulas et al., 1998). Shahrokhi et al., in 2013, initiated an investigation on the  
64 suiTable baffle, which helps the PST to have a calm-streamline flow field. They found an accurate position  
65 and height of a baffle in a rectangular primary sedimentation tank (Shahrokhi et al., 2013). Vahidifar et al.,  
66 in 2018, submitted the theory of successful settling to evaluate and optimize the PSTs with the cooperation  
67 of different methods. They examined these elemental methods applying the short-circuiting phenomenon  
68 and the successful settling theory (Vahidifar et al., 2018).

69 Simple elementary evaluation on the preceding-declared researches will show that none of them use  
70 one required combination. The mixture of experimental, statistical analysis and evolutionary methods for  
71 evaluating the optimization of the PSTs. Consequently, the development of an efficient PST can be  
72 considered as a research gap. Optimization models play a crucial role in designing PSTs because of their  
73 serious sensitiveness. They will boost the design, and by this cooperation, the process will encounter fewer  
74 errors.

75 The main targets of this paper are to satiate this research gap by the plan which are set out as follows:

- 76 (i) Defining cost functions for designing PSTs based on economic, process modification, and  
77 reactor efficiency.
- 78 (ii) Optimizing the functional parameters for PST design by applying the Central Composition  
79 Design (CCD) and Response Surface Methodology (RSM).
- 80 (iii) Sensitive analysis of designing as per Scenario Building Method (SBM).
- 81 (iv) Applying Genetic Algorithm (GA), Pattern Search Algorithm (PSA) and Simulate Annealing  
82 Algorithm (SAA) for calibrating non-linear regression predictive equations.
- 83 (v) Validating the models with real experimental hydraulic testing in lab-scale setup.

84 Other sections of this paper are summarized as follows: Section 2 explores the materials and methods  
85 including the framework of this research, used statistical and numerical methods, lab-scale setup and SBM  
86 assumptions. Section 3 provides an extensive analysis and in-depth discussion from results. Finally, Section  
87 4 reviews a summary for this paper with recommendations and future research opportunities.

## 88 2. Materials and methods

89

### 90 2.1. Case study and experiments

91 The present research is done for optimizing the PST of industrial wastewater treatment plant which is  
92 located in **Mashhad city, Iran** as per Fig. 1. Likewise, the average specification of the mentioned case study  
93 is summarized based on Table 1.

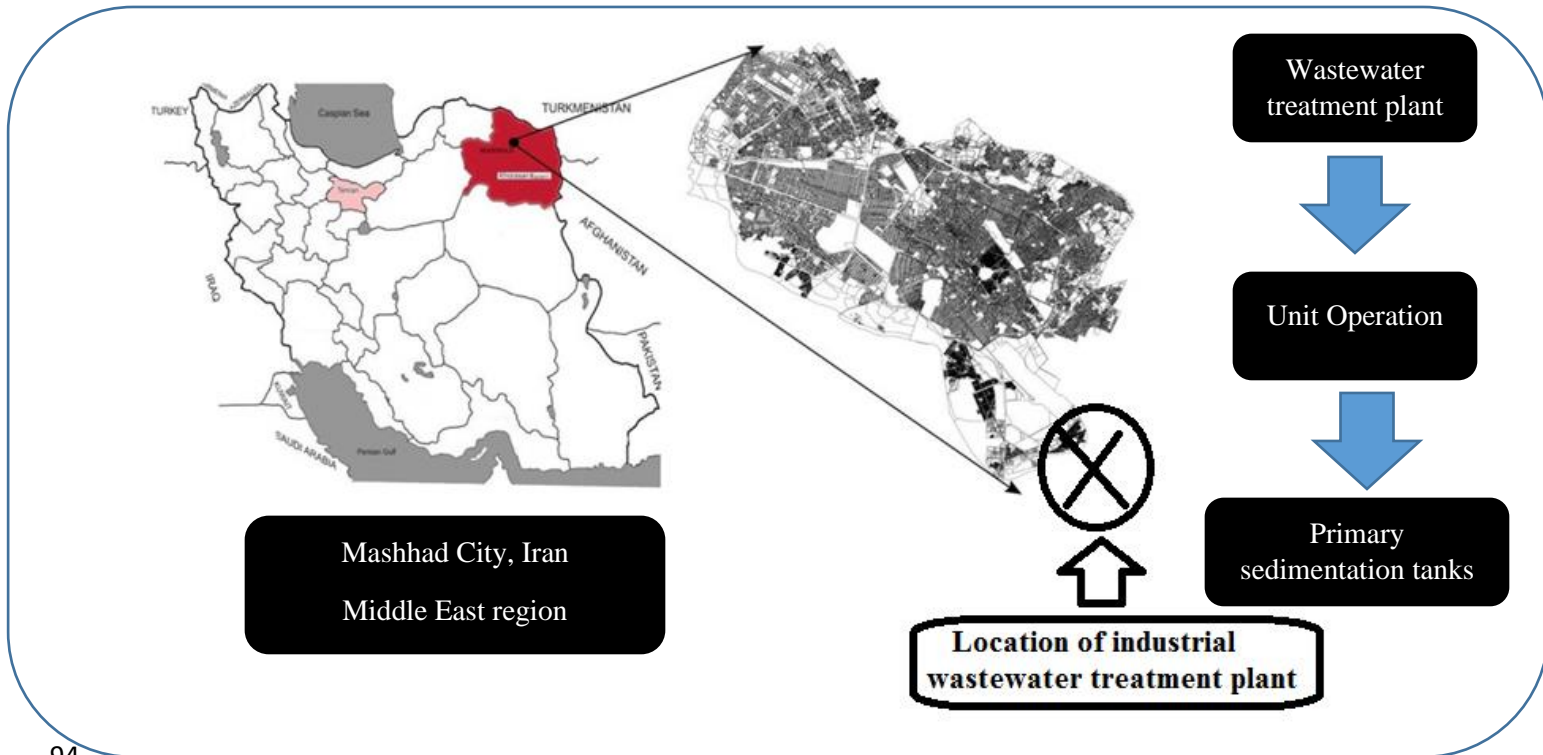

94

95 **Fig. 1. Location of industrial wastewater treatment plant in Mashhad, Iran.**

96 In the end of statistical modelling and optimizations, for comparing the results of each mathematical model  
97 such as GA, PSA and SAA, some experimental runs are done in lab-scale adjustable setup according to Fig.  
98 2. The mentioned environmental hydraulic lab is located in Mashhad city. In each run, the optimum  
99 conditions of PST design are set in size adjustable lab-scale setup and the outcomes of it is asset. Plus, the  
100 experimental results are compared with output of each mathematical model and they are authorized in this  
101 method as per error value. The mentioned setup is invented by Poly (methyl methacrylate) (PMMA)  
102 material and also, for experimental evaluations, all optimum dimensions are scaled in lab scale setup.

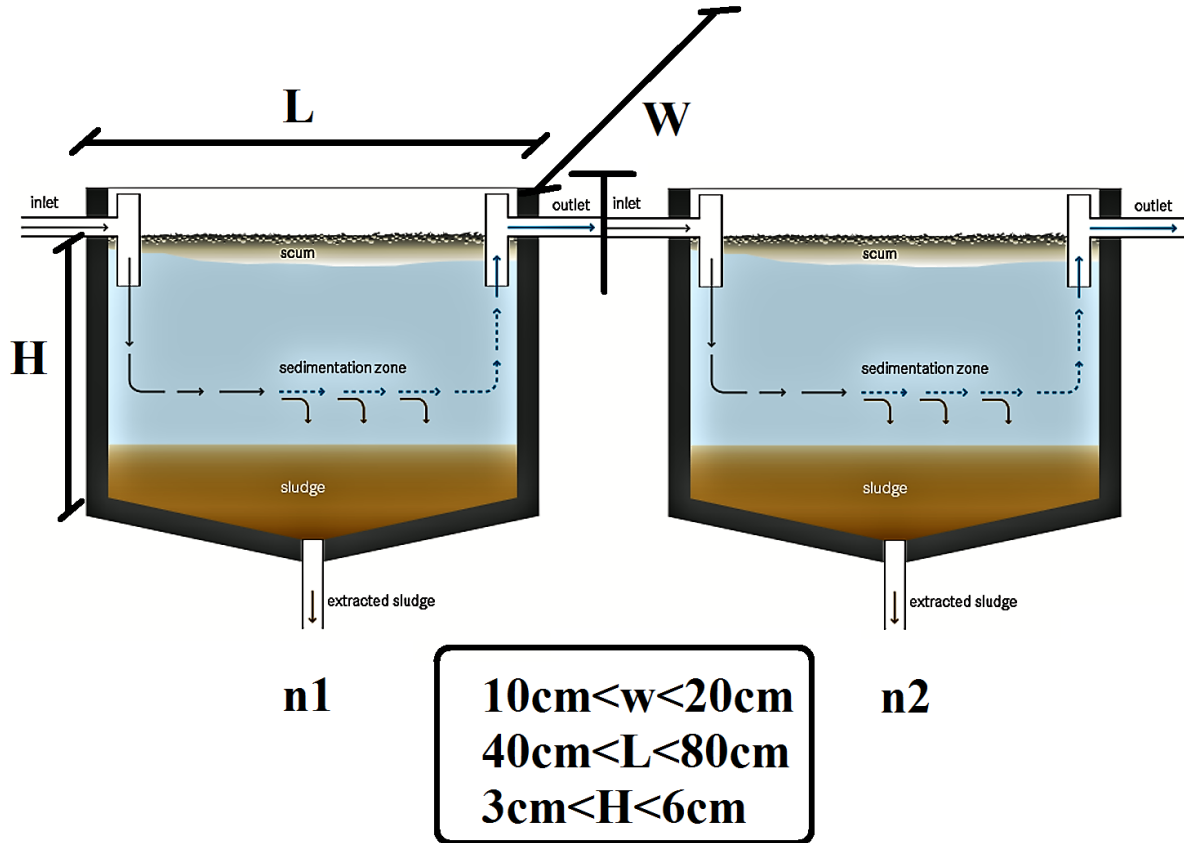

103

104

Fig. 2. Schematic plan of lab scale PST in present study.

105

Table 1. Specification of raw wastewater in present research.

Parameter	Unit	Value
Wastewater flow	m <sup>3</sup> /h	210
Chemical Oxygen Demand	mg/l	780
Total Suspended Solid	mg/l	325
Temperature	°C	21
pH	—	8.2
Dissolved Oxygen	mg/l	6.4

106

## 107 2.2. Research methodology

108 The research methodology of present study is illustrated in Fig. 3 which is divided to four sections  
 109 containing statistical computations, SBM implementation, numerical calculations and experimental  
 110 practices. First, the algorithm of CCD-RSM is run and then different designing/reengineering situations are  
 111 appraised by SBM. The outcomes of SBM are optimized by three GA, PSA and SAA algorithm. For judging  
 112 between the declared optimization methods, some experimental evaluations are done in lab scale setup.

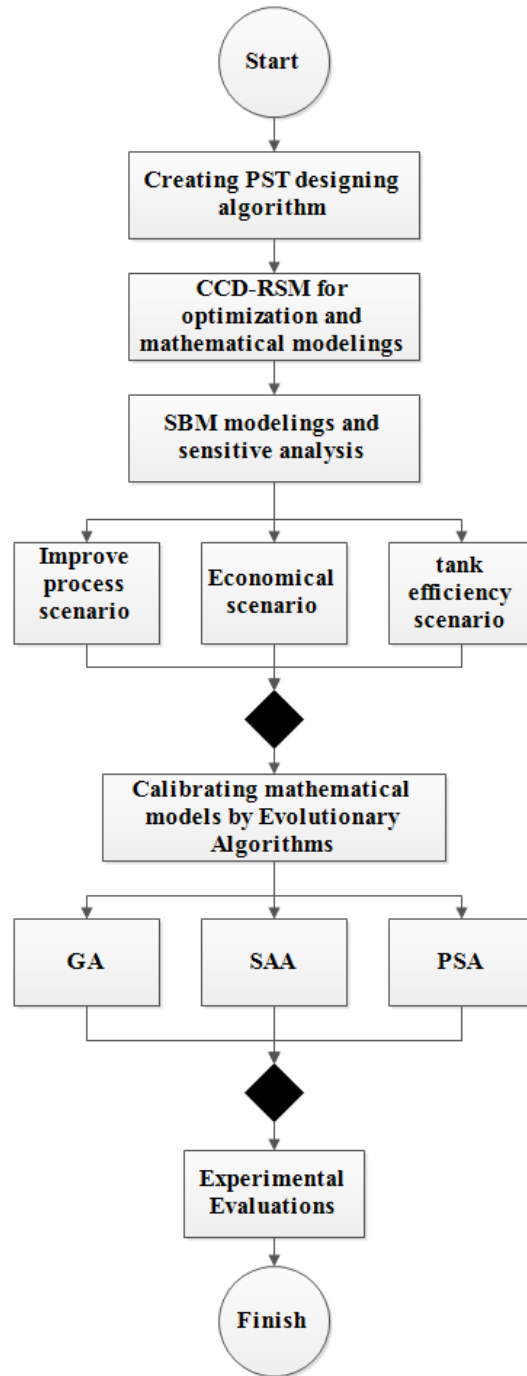

Fig. 3. Research methodology in the present study.

### 2.3. Proposed PST

To design PSTs, usage of Fluid Mechanic's Continuity relations is undeniable. By assuming the mean wastewater flow as 'Q Ave' and the maximum flow as 'Q Max', PSTs' designing algorithm is illustrated in Fig. 4 (Kirishima et al., 2021; Xu et al., 2021).

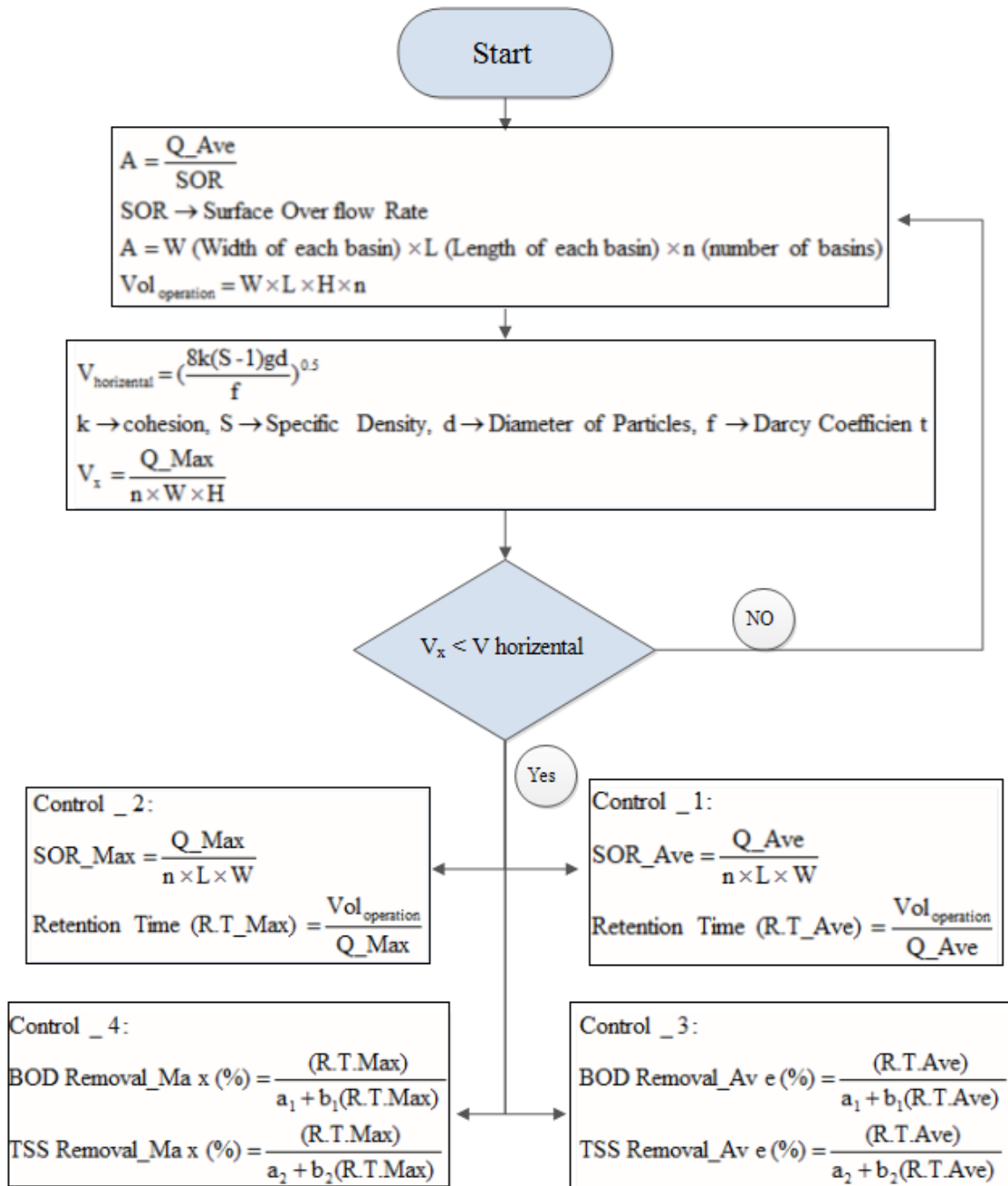

Fig. 4. PSTs' computational design

$a_1 = 0.018, b_1 = 0.020, a_2 = 0.0075, b_2 = 0.014$  (Vesilind, 2013; Henze et al., 2008; Russell, 2019)

119  
120  
121  
122

123 As shown in Fig. 2, the number of tanks (n), the Width of any rectangular tank (W), Length of the  
124 tanks (L), the Height of the tank (H), and the Surface Overflow Rate (SOR) should be determined as the  
125 first step of designing. In the following, the design will be developed, and according to Fig. 4, the  
126 computation of all the system's members will be done. Hence, using the CCD-RSM algorithm (Vesilind,  
127 2013; Henze et al., 2008; Russell, 2019) is indisputable for the optimization of the design's features and

128 effective parameters. The introduced algorithm model is utilized in the MATLAB 2018b® program to run  
 129 each test inside it.

130

131 **2.4. Proposed CCD-RSM**

132 All the model's input and objective functions should be determined in the RSM optimization model.  
 133 According to the previously mentioned information (Fig. 4), the model's input factors are containing the  
 134 Number of tanks (n), the Width of any rectangular tank (W), Length of the tanks (L), the Height of the tank  
 135 (H), and the Surface Overflow Rate (SOR). The quantity of these factors is shown as per Table 2 which are  
 136 considered based on the literature review and main resources of wastewater treatment plant designing  
 137 (Karia and Christian, 2013; Benefield et al., 1984; Edward, 2019). All CCD-RSM computations are done  
 138 in Design Expert 7.0.0 software (Eftekhari et al., 2020; Eftekhari et al., 2021).

139

140 **Table 2. Input parameters in CCD-RSM model to design the PSTs.**

Parameter	Unit	Minimum (-1)	Mean (0)	Maximum (+1)
Number of tanks (n)	-	2	3	4
Width of any rectangular tank (W)	m	3	13.5	24
Length of the tanks (L)	m	15	52.5	90
Height of the tank (H)	m	3	4	5
Surface Overflow Rate (SOR)	m <sup>3</sup> .m <sup>-2</sup> .d <sup>-1</sup>	30	40	50

141

142 Objective functions should be determined to evaluate the process of each sketched test. In this part  
 143 of the design, objective functions have economic, process and efficiency issues. Economic functions depend  
 144 on construction's cost, volume, and the number of the PSTs (F1) while the process functions rely on the  
 145 four constraints shown in Fig. 2. Also, the efficiency functions are related to Biochemical Oxygen Demand  
 146 (BOD) and Total Suspended Solid (TSS) elimination. All these functions are shown in Table 3. The  
 147 mentioned functions are designed according to basic equations (Metcalf et al., 1991; Tchobanoglous et al.,  
 148 2003) and just, through this study, the functions are converted to error formula in comparison of ideal values  
 149 as per basic references.

150 **Table 3. Objective functions in the CCD-RSM model to design PSTs.**

Number	Function's type	Optimization terms	Objective function's Equation
1	economic	minimum	$f_1 = n' W' L' H' \text{ Constand Cost}$

2	Improving process	minimum	$f_2 = (\text{SOR\_Max} - 120)^2 + (\text{SOR\_Max} - 80)^2$
3	Improving process	minimum	$f_3 = (\text{SOR\_Ave} - 50)^2 + (\text{SOR\_Ave} - 30)^2$
4	Improving process	minimum	$f_4 = (\text{R.T\_Max} - 2.5)^2 + (\text{R.T\_Max} - 1.5)^2$
5	Improving process	minimum	$f_5 = (\text{R.T\_Ave} - 2.5)^2 + (\text{R.T\_Ave} - 1.5)^2$
6	Tank efficiency	maximum	$f_6 = \frac{(\text{R.T.Max})}{a_1 + b_1(\text{R.T.Max})}$
7	Tank efficiency	maximum	$f_7 = \frac{(\text{R.T.Max})}{a_2 + b_2(\text{R.T.Max})}$
8	Tank efficiency	maximum	$f_8 = \frac{(\text{R.T.Ave})}{a_1 + b_1(\text{R.T.Ave})}$
9	Tank efficiency	maximum	$f_9 = \frac{(\text{R.T.Ave})}{a_2 + b_2(\text{R.T.Ave})}$

151

152 According to the experimental information exist in the reference resources, the maximum quantity  
153 of SOR in PSTs should be 80-120 m<sup>3</sup>.m<sup>-2</sup>. s. Accordingly, the 'f2.' function is shaped based on the interval  
154 among the stated parameters and the maximum SOR quantity. This amount is balanced by 30-50 for the  
155 average SOR and is viewed in the 'f3.' function. 'f4.' and 'f5.' functions have deemed a controller to the  
156 Retention Time (RT) in 'Q Ave' and 'Q Max' terms with the minimum quantity of 1.5 hours and the  
157 maximum amount of 2.5 hours (Karia and Christian, 2013; Benefield et al., 1984; Edward, 2019).  
158 Moreover, the 'f6 - f9' functions are linked to the exclusion percentage of BOD and TSS values and are the  
159 same as the maximum functions.

## 160 2.5.SBM system

161 With due attention to the fact that 'f1-f9' functions are some maximum and some minimum  
162 functions, all these objective functions should convert to a dimensionless quantity during each test with  
163 incommensurable methods. In the following, the Relation Deviation Index (RDI) method will be used to  
164 make the numerical quantities of the objective functions dimensionless, as shown in Equation 1 (Erfani et  
165 al., 2019).

$$166 \quad \text{RDI} = \frac{|f_i - f_{best}|}{|f_{max} - f_{min}|} \quad \text{Equation 1}$$

167 After the incommensurability, different scenarios can be formed for the 'f1-f9' functions'  
168 interactions by weighting each function. Some of these scenarios are shown in Equation 2. Moreover, it is  
169 probable to use decision analysis' like Multi-Criteria Decision Making (MCDM) to weighting these  
170 functions. For determining each scenario's weights, the Shannon Entropy (SE) method is performed,



171 illustrated in Fig. 5 (Gheibi et al., 2019). Plus, eight experts, including five wastewater treatment plant  
 172 designer and three system operators are interviewed in the present study. This problem can be analyzed and  
 173 examined as a multi-purpose function too. But, because of the increasing number of objective functions,  
 174 the convergent probability is much less. Consequently, by the scenarios shown in Equation 2, the  
 175 predicament situation will converge to an exclusive destination response. In the declared Equation, as an  
 176 indicator's weight is low; Its priority is powerful because the RDI approach will make all the functions least  
 177 and minimum.

178

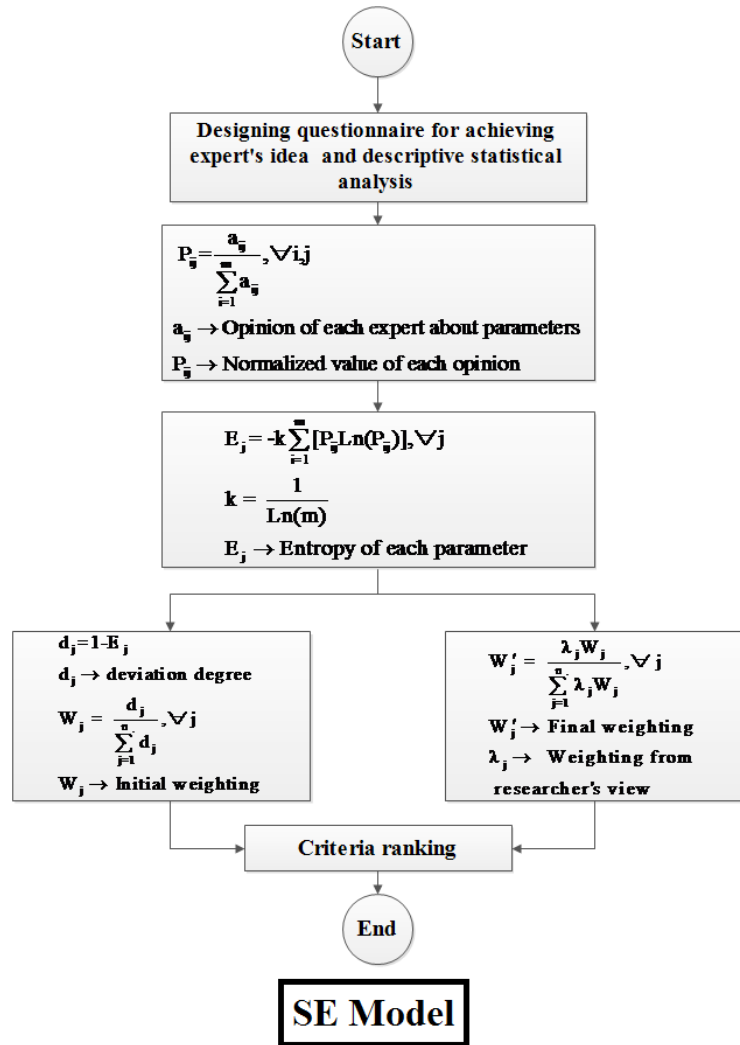

179

180

Fig. 5. Algorithm of SE computation in present investigation.

181

182

183

184

185  
186  
187

**Equation 2**

$$f_{Total} = \sum w_i f_i$$

Scenario1 (Economical Scenario) ®  $w_1 = 0.022, w_2 = 0.122, w_3 = 0.122$

$w_4 = 0.122, w_5 = 0.122, w_6 = 0.122, w_7 = 0.122, w_8 = 0.122, w_9 = 0.122$

188 Scenario2 (Improve Process Scenario) ®  $w_1 = 0.164, w_2 = 0.04, w_3 = 0.04$

$w_4 = 0.04, w_5 = 0.04, w_6 = 0.164, w_7 = 0.164, w_8 = 0.164, w_9 = 0.164$

Scenario3 (Tank efficiency Scenario) ®  $w_1 = 0.164, w_2 = 0.164, w_3 = 0.164$

$w_4 = 0.164, w_5 = 0.164, w_6 = 0.04, w_7 = 0.04, w_8 = 0.04, w_9 = 0.04$

189

190 Evaluating these Equations will reveal that scenarios 1, 2, and 3, are focusing on economic, process  
191 improvement, and tank efficiency, respectively. These scenarios can be regulated to satisfy the designer's  
192 and employer's demands. As per previous notices, all weights of Equation 2 are determined as per the  
193 opinion of 8 experts and they are computed based on the mean weight of gathered scores by experts. In  
194 each scenario, the study asked the experts to imagine the importance of economic, improve process, and  
195 tank efficiency are more than others through each scenario and then they assign scores. Finally, the  
196 functions are minimization type and because of this fact, the declared weights are reversed and then  
197 assigned.

198 Firstly, the PSTs design steps are outlined in the MATLAB programming facade. Secondly, tests  
199 are designed by the input parameters shown in Table 1 and CCD-RSM methods that are shown in Table 2.  
200 Moreover, the objective functions of each test, conducted in Table 3, are determined. After the non-scaling,  
201 the scenarios shown as per Equation 2, they will convert to an individual purpose function. Finally, all the  
202 test's and scenario's conditions will be evaluated in the designed model. It is necessary to mention that the  
203 sketch in CCD-RSM method is composed of 5 levels and the alpha factor is set equal to 1.2. Through the  
204 CCD-RSM computations, due to evaluation of response's fluctuations in the neighbor of maximum and  
205 minimum values of input data and rechecking the response of numerical boundaries based on output  
206 function values alpha factor is adjusted. About alpha factor, a value less than one puts the axial points in  
207 the cube; a value equal to one puts them on the faces of the cube; and a value greater than one puts them  
208 outside the cube. Therefore, with 1.2 amount, the variations of response are detected as safety factors of the  
209 optimization procedure. The exact value of alpha is determined based on the try and error method and the  
210 input parameters should be meaningful and in a logical range. In the Design Factor program, the minimum  
211 test numbers elected as 26 tests for five effective parameters. In Table 4 the "4.2" and "1.8" values are  
212 considered equal to "5" and "1" amounts, respectively, to be meaningful as n value.

213

**Table 4. Producing the PSTs designs according to the RSM-CCD methods.**

run	n	W	L	H	SOR
1	3	13.5	52.5	4	40
2	4	24	15	5	30
3	3	13.5	52.5	2.8	40
4	1.8	13.5	52.5	4	40

5	3	13.5	52.5	4	40
6	2	3	15	3	30
7	3	13.5	7.5	4	40
8	2	3	90	5	50
9	3	0.9	52.5	4	40
10	4	3	90	3	50
11	3	13.5	52.5	4	52
12	2	24	15	5	50
13	4.2	13.5	52.5	4	40
14	4	3	90	5	30
15	4	3	15	5	50
16	3	13.5	52.5	4	40
17	2	24	90	5	30
18	3	13.5	52.5	4	28
19	2	24	90	3	50
20	3	26.1	52.5	4	40
21	4	24	15	3	50
22	3	13.5	52.5	4	40
23	3	13.5	52.5	4	40
24	3	13.5	97.5	4	40
25	4	24	90	3	30
26	3	13.5	52.5	5.2	40

214

215 **2.6. Proposed metaheuristics**

216 In present research, after computing mathematical Equation from CCD-RSM, the outcomes of the  
 217 mentioned computations will be calibrated by three GA, PSA and SAA algorithms as the efficient  
 218 metaheuristic methods in the literature. We have used the Optim Tool of MATLAB platform. In the three  
 219 GA, SAA and PSA algorithms adjustment parameters are set as per Equation 3-5, correspondingly. Since  
 220 these metaheuristics have been defined in many relevant works, their description is not provided and  
 221 referred to the recent papers: (Fathollahi-Fard et al., 2020a; Fathollahi-Fard et al., 2020b; Fathollahi-Fard  
 222 et al., 2020c; Fathollahi-Fard et al., 2018; Ghadami et al., 2021; Moosavi et al., 2021). **The engineering  
 223 problems are solved by the application of metaheuristic algorithms based on natural behaviors. Therefore,  
 224 in the SAA the temperature just is a mathematical character and the physical aspects of it is not considered  
 225 in present study. Also, through the SAA, the initial temperature factor should be selected based on try and  
 226 error method with considering to minimum value of the cost function. While, In the present investigation,  
 227 the temperature in SAA is assumed equal to 120 o<sup>C</sup> according to Aleksendrić and Carlone (2015) in the  
 228 similar study.**

229

**Equation 3**

- Mutation Rate ® 0.01
- Cross Over Probability ® 0.8
- Initial Population ® 50
- Number of Iteration ® 50

230

231 Equation 4

Temperature Update Function ® Exponential temperature function

232 Reannealing Interval ® 100

Initial Temperature ® 120 °C

Number of Iteration ® 50

233 Equation 5

Poll Method ® GPS Positive basis N2

Expansion Factor ® 4

234 Mesh Initial Size ® 3

Contraction Factor ® 0.5

Mesh Tolerance ® 1e-6

235 In the last stage of this research, the efficiency of designed reactors based on integration of CCD-RSM and  
236 metaheuristic algorithms is evaluated in lab scale setup (Fig. 2) in optimum conditions and in time variation.  
237 Also, with the mentioned experimental practices, behavior of reactors is compared by CCD-RSM and GA,  
238 PSA and SAA outcomes as prediction systems. Finally, the efficiency of BOD<sub>5</sub> and TSS removal are  
239 appraised in three time periods containing 1, 2 and 3 hours according to standard methods for water and  
240 wastewater examinations (Gheibi et al. 2021).

### 241 3. Result and discussion

242 In results and discussion section mathematical modelling and experimental practices, managerial  
243 insights, sustainability and operational framework are argued.

#### 244 3.1. Mathematical modelling and experimental practices

245 Results of PSTs designing in CCD-RSM technique are illustrated in Fig.6, according to the  
246 determined experiments in Table 4. It is essential to say that mean flow (Q-Ave), maximum flow (Q Max),  
247 cohesion coefficient (K), particles mean diameter (d), particles relative density (S), and runoff coefficient  
248 (f) in the intended sewage-treatment plant are sequential as 15000 m<sup>3</sup>. d<sup>-1</sup>, 45000 m<sup>3</sup>. d<sup>-1</sup>, 0.07, 100 microns,  
249 1.36, 0.028 (Yaseen et al., 2021; Al-Mafraji et al., 2021; Novikov et al., 2021; Leung et al., 2021).  
250 According to Fig. 6, f1, f5, f6, and f8 have the most fluctuations through all optimization runs and the  
251 standard deviations of them are more than other functions. With consideration to the range of fluctuations,  
252 the optimization process is so complex and in the real designing process, the role of integrated CCD-RSM  
253 and metaheuristic algorithms is determined more than more. The values in Fig. 6 are normalized in range  
254 of 0-1 and the closer these values are to zero, the better results occur.

255  
 256  
 257  
 258  
 259  
 260  
 261  
 262  
 263  
 264  
 265  
 266  
 267  
 268  
 269  
 270

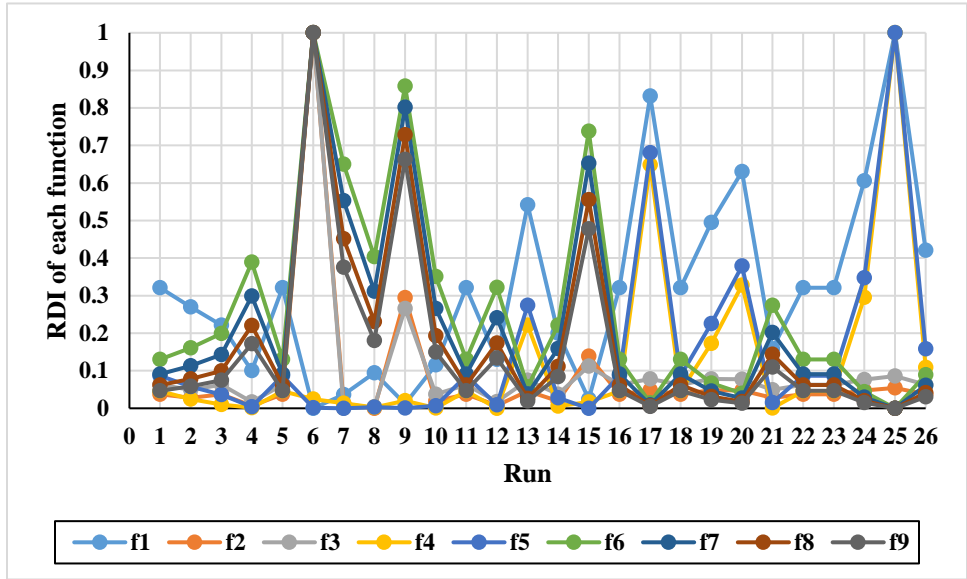

**Fig.6. Planned tests' data distribution in PSTs designing.**

According to the Fig.6, it is understandable that the quantity of f1-f9 functions is different in each test. These quantities should convert to a response surface according to the scenarios defined in Equation 2 after computations. As the final step, analysis related to each scenario's superposition of nine functions will be evaluated. The product result of function's weight at RDI quantity of each test for economic scenario is shown in Fig.7.

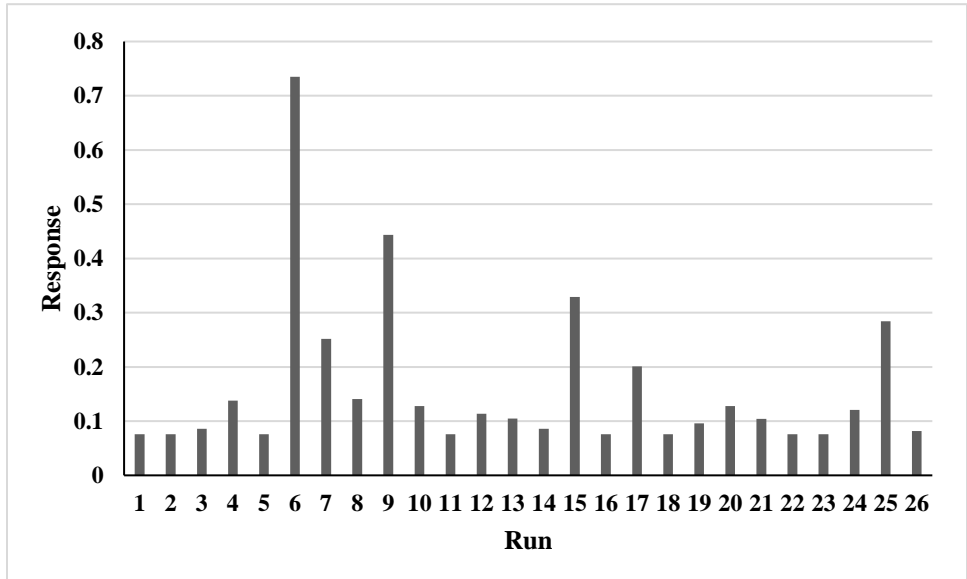

**Fig.7. Planned tests' results for PSTs designing in economic scenario.**

271  
 272  
 273  
 274  
 275  
 276

After the statistical analysis of tests results in the economic scenario, a quadratic model with the regression coefficient of 0.99 obtained to predict the response surface which is shown in the Equation 6. The reduced version of equations according to importance of parameters are presented in the following of each formula.

277 On the other words, the unnecessary factors are eliminated in the equations and just, high weight parameters  
 278 are presented. The importance of each term is determined according to their coefficient value as their  
 279 weights.

280 **Equation 6**

281 **Response** = +0.50627 - 0.054971\*n - 0.13047\* W - 0.010069\* L + 0.21522\* H + 0.026489\* SOR  
 282 + 8.77372E-003\* n \* W + 6.30309E-004\* n \* L - 0.030795\* n \* H - 1.51847E-003\* n \* SOR +  
 283 4.11796E-004\* W \* L + 5.87990E-003\* W \* H + 3.87429E-004\* W \* SOR-1.54210E-004\* L \*  
 284 H- 6.25939E-005\* L \* SOR - 2.14394E-003\* H \* SOR + 0.012270\* n<sup>2</sup> + 1.14781E-003\* W<sup>2</sup>+  
 285 4.08207E - 005\* L<sup>2</sup> - 0.013774\* H<sup>2</sup> - 1.91272E-004\* SOR<sup>2</sup>

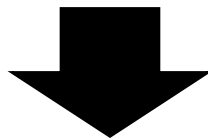

289 **Response (Reduced form)** = +0.50627 - 0.054971\*n - 0.13047\* W - 0.010069\* L + 0.21522\* H  
 290 + 0.026489\* SOR - 0.030795\* n \* H + 0.012270\* n<sup>2</sup> - 0.013774\* H<sup>2</sup>

292 In following, a sensitivity analysis of parameters that influence the designing planned, Analysis of  
 293 Variance (ANOVA) results of the existing model is demonstrated in Table 5.

294 **Table 5. ANOVA analysis of parameters that influence PSTs design in economic scenario.**

Source	Sum of Squares	df	Mean Square	F Value	p-value (Prob > F)	
<b>Model</b>	0.553132	20	0.027657	51.13501	0.0002	significant
<b>A-n</b>	0.000543	1	0.000543	1.00461	0.3622	-
<b>B-W</b>	0.049756	1	0.049756	91.99425	0.0002	-
<b>C-L</b>	0.008559	1	0.008559	15.82543	0.0106	-
<b>D-H</b>	9.58E-06	1	9.58E-06	0.01772	0.8993	-
<b>E-SOR</b>	0	1	0	0	1.0000	-
<b>AB</b>	0.014814	1	0.014814	27.38977	0.0034	-
<b>AC</b>	0.000975	1	0.000975	1.803066	0.2371	-
<b>AD</b>	0.001655	1	0.001655	3.060622	0.1406	-
<b>AE</b>	0.000402	1	0.000402	0.744139	0.4278	-
<b>BC</b>	0.045891	1	0.045891	84.84907	0.0003	-
<b>BD</b>	0.006653	1	0.006653	12.30158	0.0171	-
<b>BE</b>	0.002889	1	0.002889	5.3408	0.0688	-
<b>CD</b>	5.84E-05	1	5.84E-05	0.107928	0.7558	-
<b>CE</b>	0.000962	1	0.000962	1.778152	0.2399	-
<b>DE</b>	0.000802	1	0.000802	1.483438	0.2776	-
<b>A^2</b>	0.000744	1	0.000744	1.376013	0.2936	-
<b>B^2</b>	0.079162	1	0.079162	146.3649	< 0.0001	-
<b>C^2</b>	0.01629	1	0.01629	30.11829	0.0027	-

<b>D<sup>2</sup></b>	0.000938	1	0.000938	1.733937	0.2450	-
<b>E<sup>2</sup></b>	0.001809	1	0.001809	3.343859	0.1270	-
<b>Residual</b>	0.002704	5	0.000541	-	-	-
<b>Lack of Fit</b>	0.002704	1	0.002704	-	-	-
<b>Pure Error</b>	0	4	0	-	-	-
<b>Cor Total</b>	0.555836	25	-	-	-	-

295

296 According to Table 5, it can be concluded that the model's p-value with the amount of 0.0002 has  
 297 enough validity to predict the response surface. Moreover, the width (W) and length (L) of the PST with  
 298 the sequential p-value amount of 0.0002 and 0.0106 have the most significant influence on the response  
 299 surface in economic scenario. In the next step, the tanks number (n) and height of each tank with the  
 300 sequential p-value of 0.36 and 0.89 have the most influence on the response surface. In conclusion, it is  
 301 worth noting that the tank's width (W) factor with the p-value amount below 0.005 is the main factor in an  
 302 economic design. Binary comparison of parameters that influence the response surface is demonstrated in  
 303 Fig.8. In the parameter's binary comparison, the more variation gradient of a parameter in contrast to the  
 304 economic response surface, the more it is valuable in the design. For instance, by seeing slope gradient in  
 305 the W-n curve, it can understand that the variation of PSTs' width (W) is more severe than the variation of  
 306 tanks number (n), which shows the importance of W in comparison to n.

307

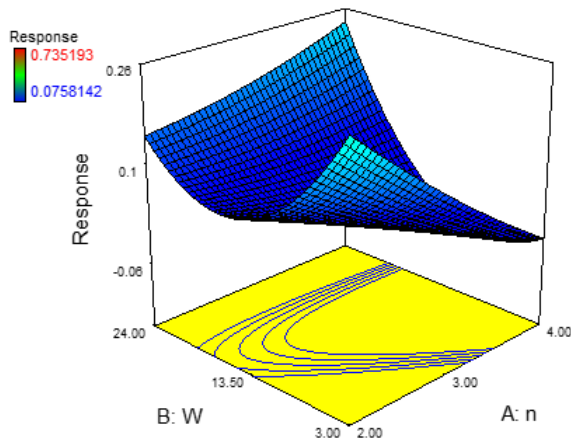

(a)

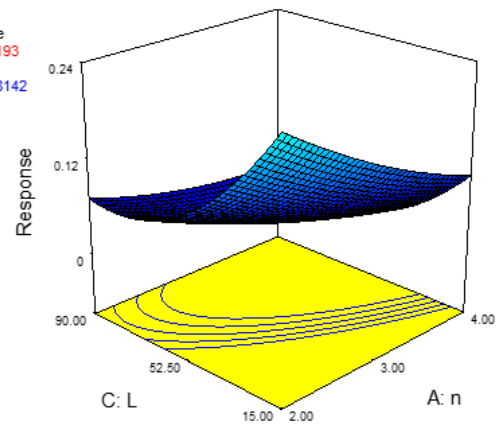

(b)

308

309

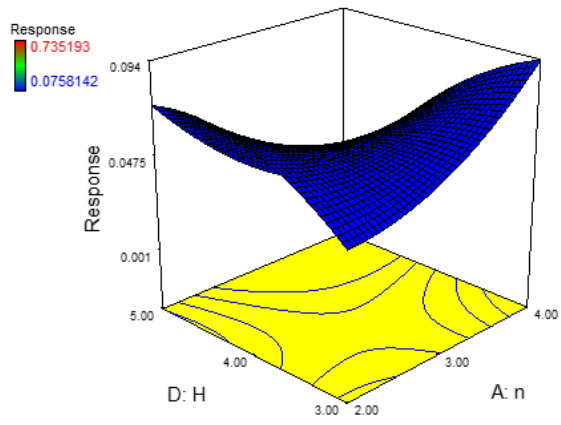

315

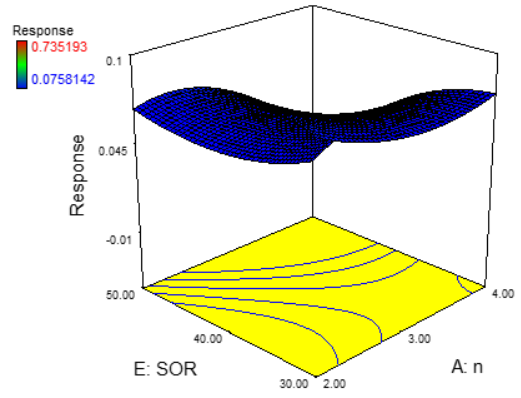

(d)

316

(c)

317

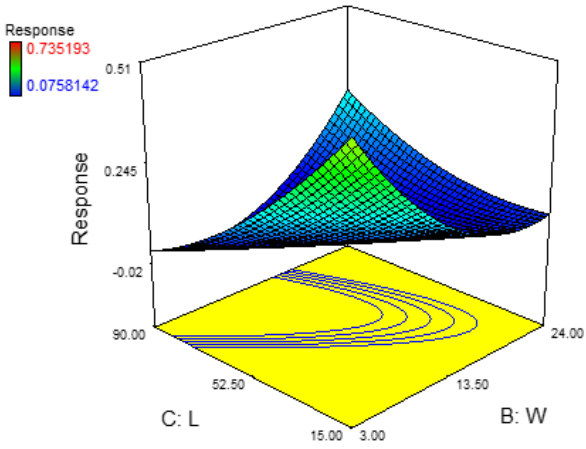

318

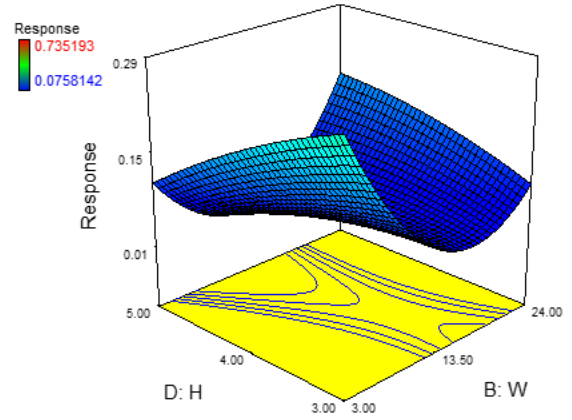

(f)

319

(e)



320

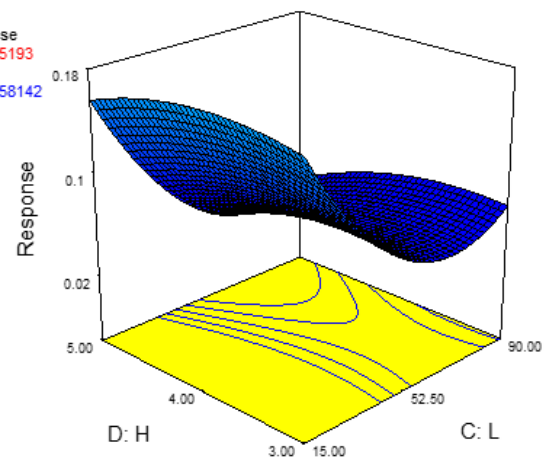
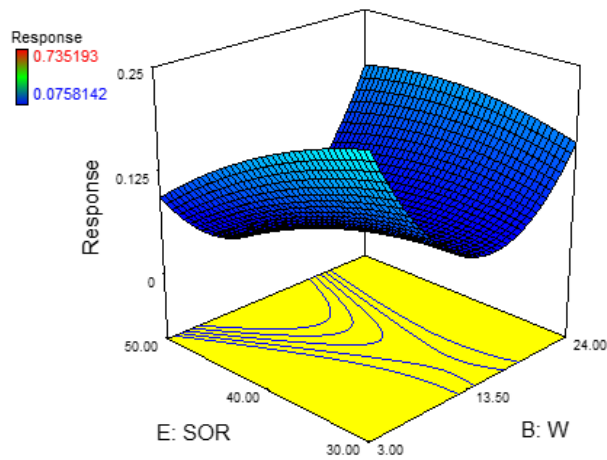

321

322

323

(g)

(h)

324

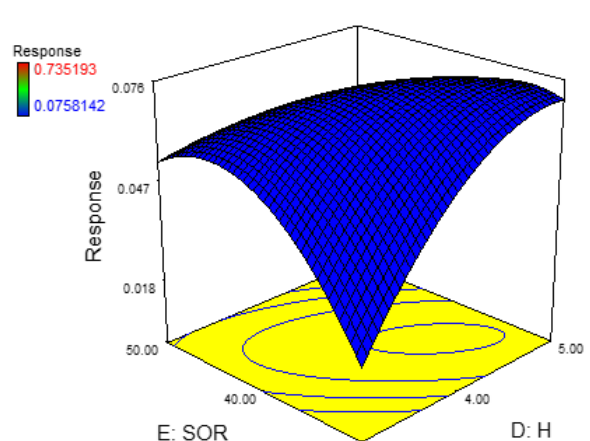
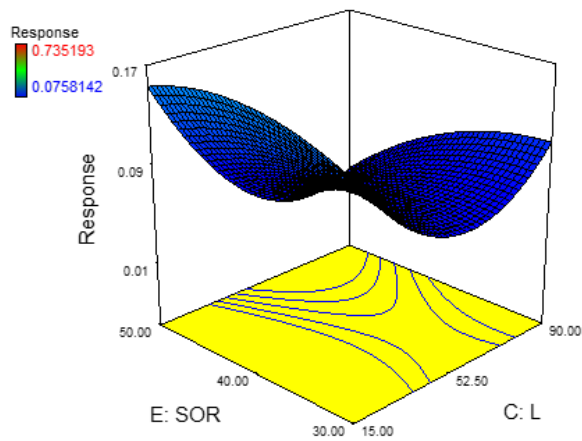

334

(i)

(j)

335

**Fig.8. Binary sensitivity analysis of parameters which influence on the response surface.**

336

337

338

Statistical distribution of CCD-RSM methods test results compared to the normal curve is depicted in Fig.9. It can understand that these tests results are not in the vicinity of the normal curve, which means the abnormal distribution of results in this scenario.

339  
340  
341

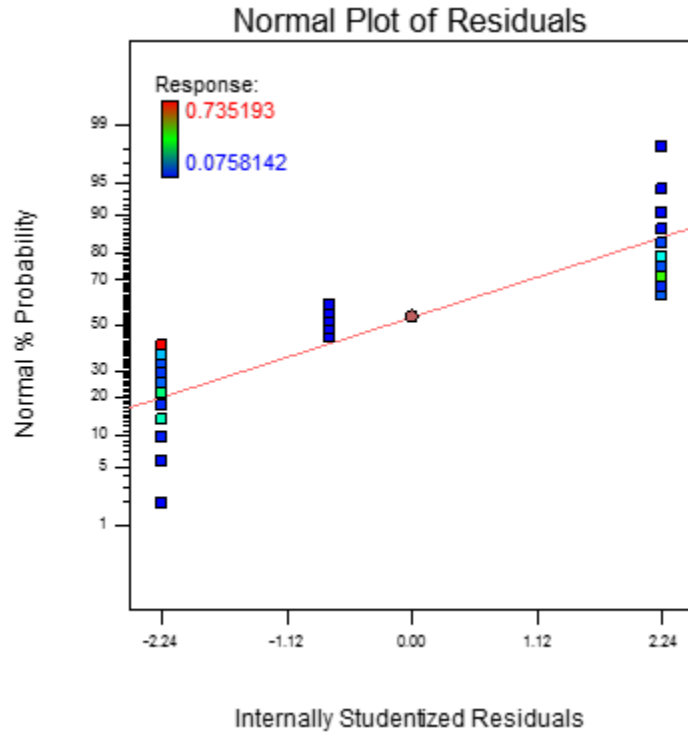

356 **Fig.9. Results distribution of economic scenario’s tests in comparison to the normal curve.**

357 According to Equation 6 in the CCD-RSM method, suggested optimal quantities are shown in Table  
 358 6. In the following, to choose a final optimal condition, each of these optimal quantities should be evaluated  
 359 in the MATLAB programming surface as per GA, PSA and SAA in Fig. 10. As per the mentioned Fig., by  
 360 application of all metaheuristic algorithms in economic scenario, the amount of cost function (Penalty  
 361 value) is reduced through the different iterations. But, the PSA struggled to optimize the error function  
 362 more than others, especially in the last iterations. It is worth noting that the vertical values in range of 0.05-  
 363 0.3 is equal to error and it is related to summation of all nine cost functions errors (Table 3).

364 **Table 6. Optimal condition suggestions in the CCD-RSM model for designing PSTs in the economic**  
 365 **scenario.**

Number	n	W	L	H	SOR	Response
1	2.06	14.6	67.65	4.82	48.8	0.073701
2	3.05	21.04	32.22	3.6	34.22	0.00649
3	3.25	22.06	20.07	3.62	43.19	0.053094
4	2.37	14.29	78.11	3.94	33.81	0.072731

366

367  
368

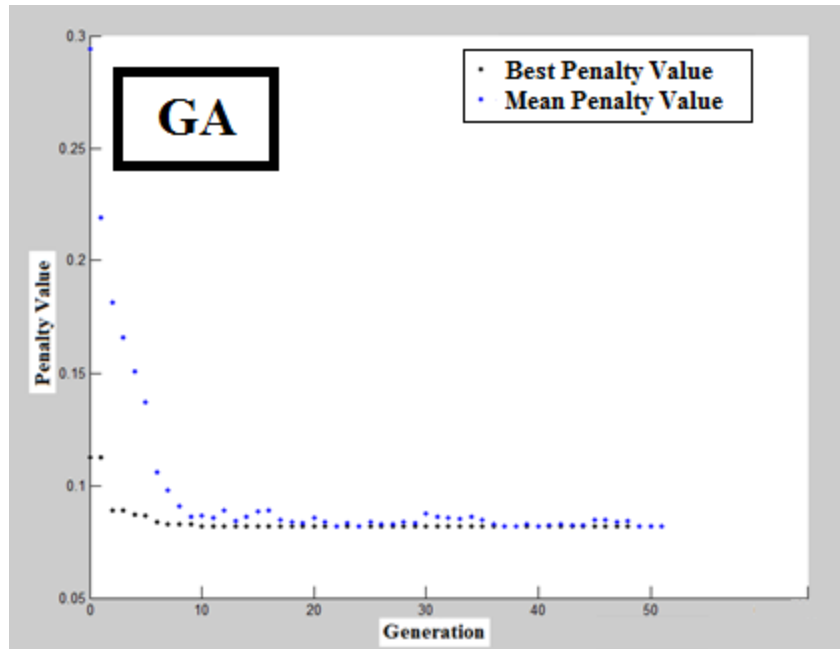

(a)

369  
370

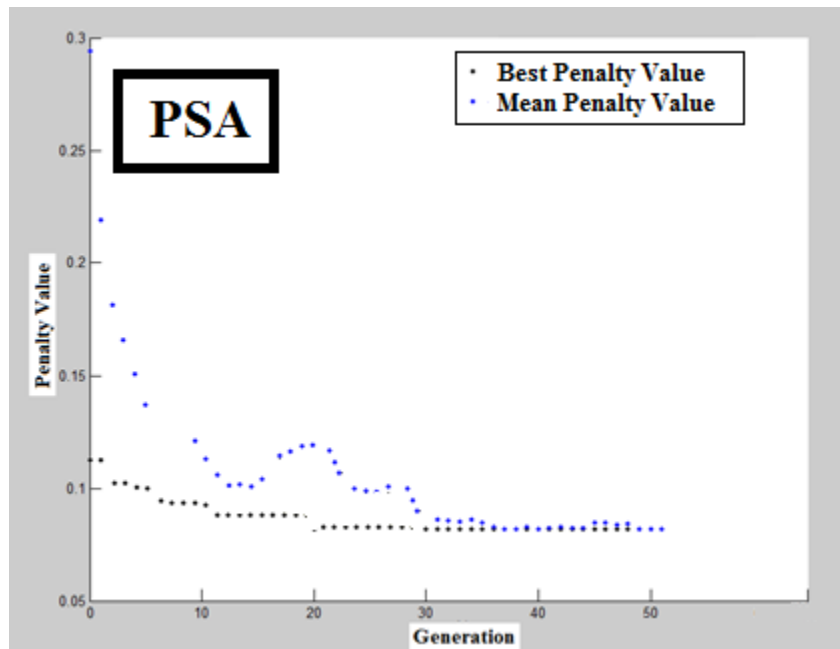

(b)

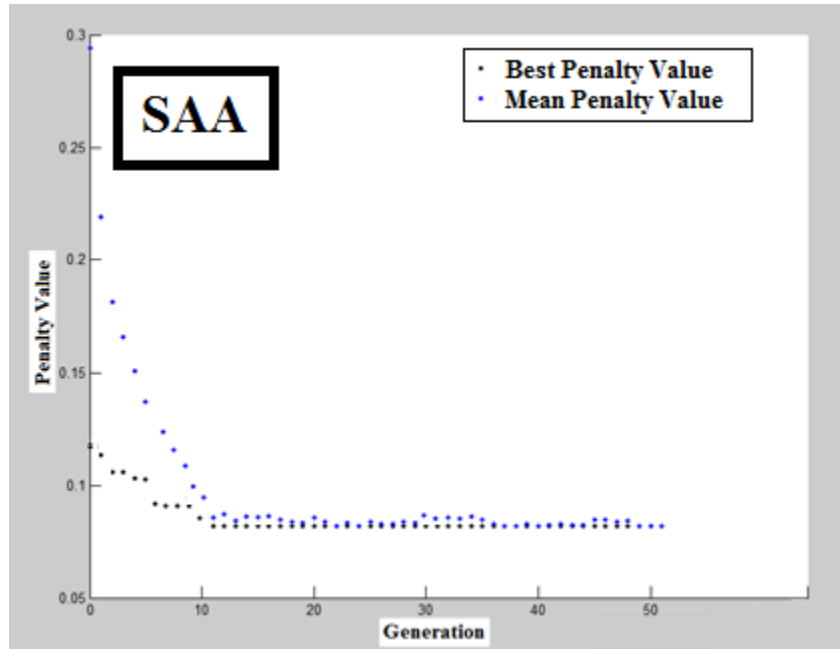

(c)

Fig.10. Calibrating process in economic scenario with (a) GA, (b) PSA and SAA.

In the followings, the outputs of RSM, GA, PSA and SAA computations are compared with mean experimental outcomes in optimum conditions as per Fig. 11. The declared comparison has been illustrated that PSA algorithm shows the best efficiency in economic scenario with 0.02 mean error value based on Equation 7. Also, in this assessment, all four suggestions are appraised and mean values are presented as an error.

**Equation 7**

$$\text{Response} = +0.452 - 0.0325*n - 0.142* W - 0.00965* L + 0.2058* H + 0.028526* \text{SOR} + 8.0569\text{E-}003* n * W + 5.985267\text{E-}004* n * L - 0.047152* n * H - 1.98065\text{E-}003* n * \text{SOR} + 4.230912\text{E-}004* W * L + 5.27419\text{E-}003* W * H + 3.6236\text{E-}004* W * \text{SOR} - 1.42985\text{E-}004* L * H - 6.01782\text{E-}005* L * \text{SOR} - 1.961045\text{E-}003* H * \text{SOR} + 0.0295598* n^2 + 0.9517207\text{E-}003* W^2 + 6.3595205\text{E-}005* L^2 - 0.012597* H^2 - 1.814036\text{E-}004* \text{SOR}^2$$



$$\text{Response (Reduced form)} = +0.452 - 0.0325*n - 0.142* W - 0.00965* L + 0.2058* H + 0.028526* \text{SOR} - 0.047152* n * H + 0.0295598* n^2 - 0.012597* H^2$$

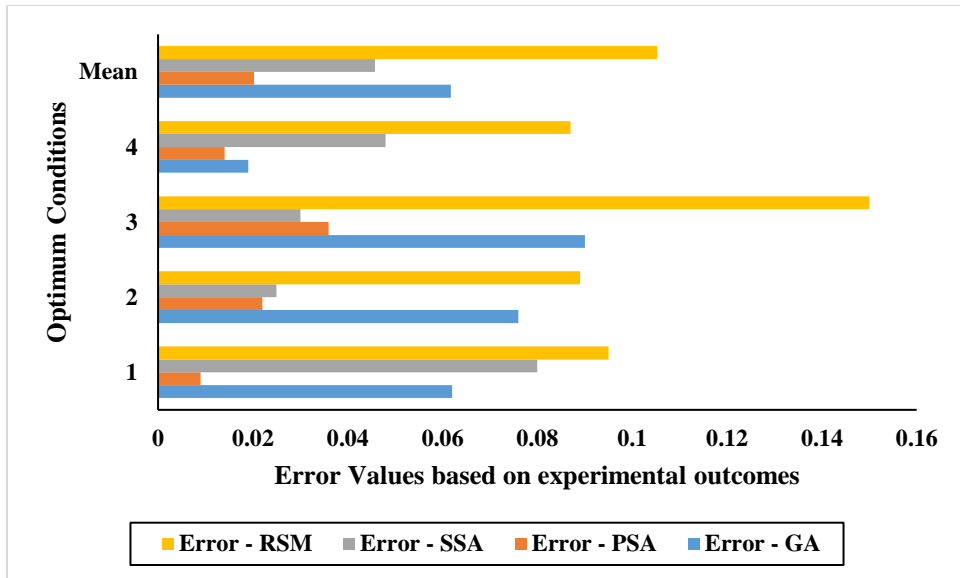

391  
 392 **Fig.11. Error values of calibrated Equations in comparison of experimental outcomes in economic scenario.**

393 In improve process scenario, to make simulations' results reach a unique aim, the product of RDI  
 394 of each function (Equation 2) and its weight (as response surface) is considered in Fig.12.

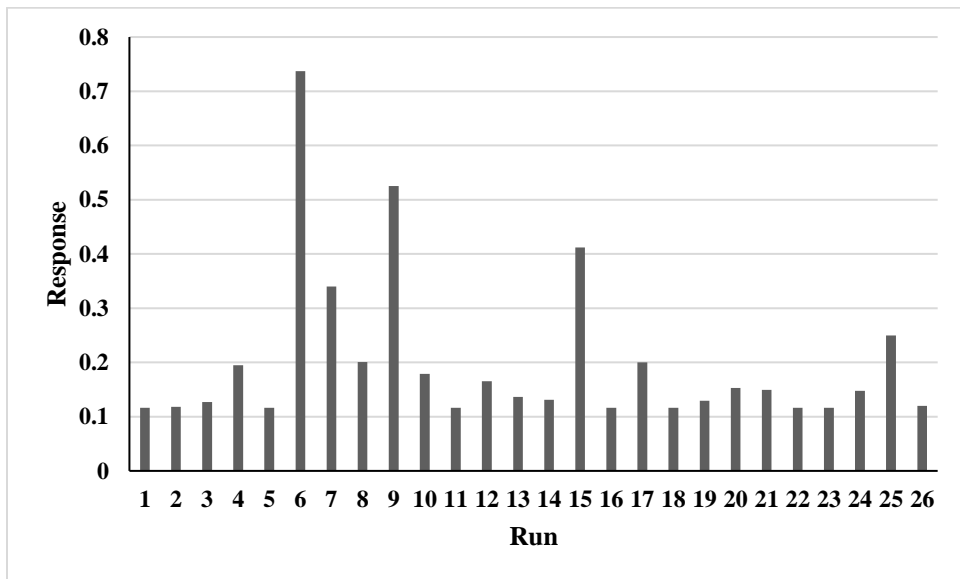

395  
 396 **Fig.12. Planned tests' results in designing PSTs in the improve process scenario.**

397 After an integrative evaluation of variable parameters' manner and the response surface, a quadratic  
 398 model with the regression coefficient of 0.99 determined to predict the response surface, which is shown in  
 399 the Equation 8.

**Equation 8**

401 **Response** = - 0.23903 + 0.048851\* n - 0.12043\* W - 8.88844E-003\* L + 0.37657\* H + 0.039770\*  
 402 SOR+ 7.43581E - 003\* n \* W + 3.59109E-004\* n \* L - 0.038342\* n \* H - 2.13657E-003\* n \*  
 403 SOR + 3.79678E-004\* W \* L + 4.60277E-003\* W \* H + 3.39347E-004\* W \* SOR - 3.97741E-

404  $004 * L * H - 6.23272E-005 * L * SOR - 3.33394E-003 * H * SOR + 7.74323E-003 * n^2 + 1.16343E-$   
 405  $003 * W^2 + 4.41420E-005 * L^2 - 0.021531 * H^2 - 2.66665E-004 * SOR^2$

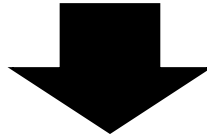

406  
 407  
 408  
 409  
 410 **Response (Reduced form) = - 0.23903 + 0.048851 \* n - 0.12043 \* W + 0.37657 \* H + 0.039770 \* SOR - 0.038342 \* n \* H - 0.021531 \* H<sup>2</sup>**

412  
 413 ANOVA results of effective parameters on the response surface are illustrated in Table 6. according  
 414 to Table 7, the model's P-Value is 0.0009, which is below 0.005 and is assured. Moreover, the width (W)  
 415 parameter and length (L) of the tank's P-value quantities are sequential 0.0005 and 0.0086, with the least  
 416 P-Value and most important influence. In the next step, the tank's number (n) and the tank's height (H) are  
 417 the parameters that influence the response surface. In conclusion, the tank's width (W) parameter has the  
 418 most influence on the response surface, and this claim was also proved in the economic scenario. Binary  
 419 sensitivity analysis of effective parameters on the response surface is shown in Fig.13.

420 **Table 7. ANOVA analysis of the effective parameters in PSTs designing in improve process scenario.**

Source	Sum of Squares	df	Mean Square	F Value	p-value (Prob > F)	
<b>Model</b>	0.546902	20	0.027345	26.01187	0.0009	significant
<b>A-n</b>	0.001698	1	0.001698	1.615328	0.2597	-
<b>B-W</b>	0.069473	1	0.069473	66.08564	0.0005	-
<b>C-L</b>	0.018454	1	0.018454	17.55425	0.0086	-
<b>D-H</b>	2.27E-05	1	2.27E-05	0.0216	0.8889	-
<b>E-SOR</b>	0	1	0	0	1.0000	-
<b>AB</b>	0.01064	1	0.01064	10.12163	0.0245	-
<b>AC</b>	0.000317	1	0.000317	0.301114	0.6068	-
<b>AD</b>	0.002566	1	0.002566	2.440943	0.1790	-
<b>AE</b>	0.000797	1	0.000797	0.757969	0.4238	-
<b>BC</b>	0.039012	1	0.039012	37.10962	0.0017	-
<b>BD</b>	0.004077	1	0.004077	3.878221	0.1060	-
<b>BE</b>	0.002216	1	0.002216	2.10806	0.2062	-
<b>CD</b>	0.000388	1	0.000388	0.369384	0.5699	-
<b>CE</b>	0.000954	1	0.000954	0.907054	0.3846	-
<b>DE</b>	0.00194	1	0.00194	1.84557	0.2324	-
<b>A^2</b>	0.000296	1	0.000296	0.281943	0.6182	-
<b>B^2</b>	0.081332	1	0.081332	77.36645	0.0003	-
<b>C^2</b>	0.019048	1	0.019048	18.11943	0.0080	-
<b>D^2</b>	0.002292	1	0.002292	2.180025	0.1998	-
<b>E^2</b>	0.003515	1	0.003515	3.343859	0.1270	-
<b>Residual</b>	0.005256	5	0.001051	-	-	-
<b>Lack of Fit</b>	0.005256	1	0.005256	-	-	-

<b>Pure Error</b>	0	4	0	-	-	-
<b>Cor Total</b>	0.552158	25	-	-	-	-

421

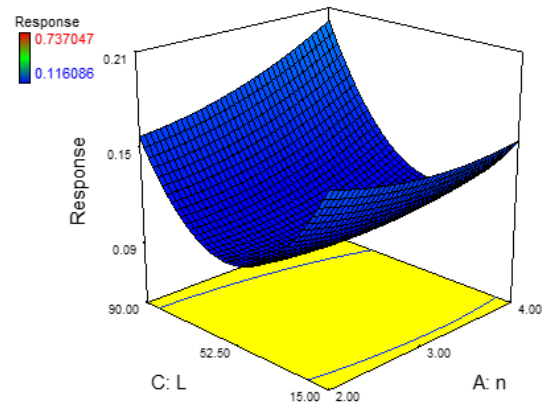
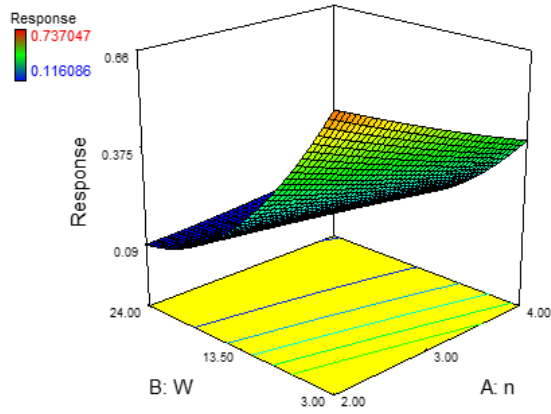

434

435

(a)

(b)

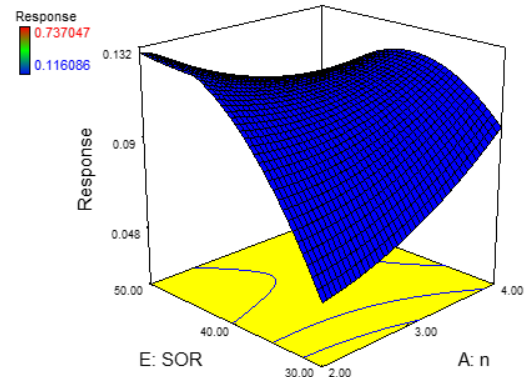
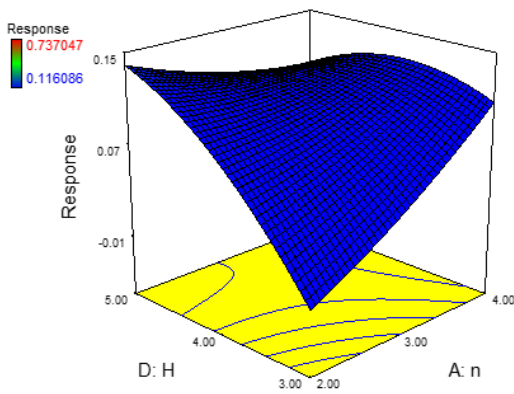

438

(c)

(d)

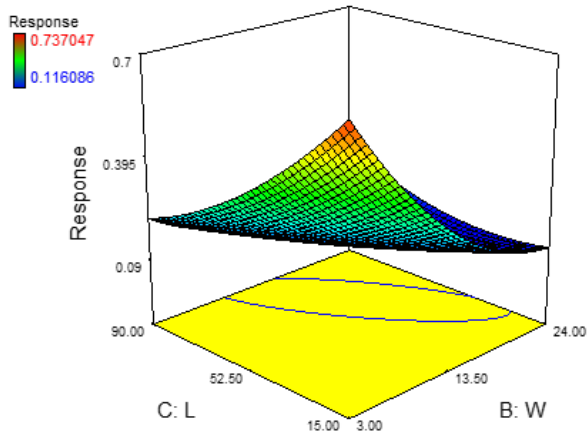

439

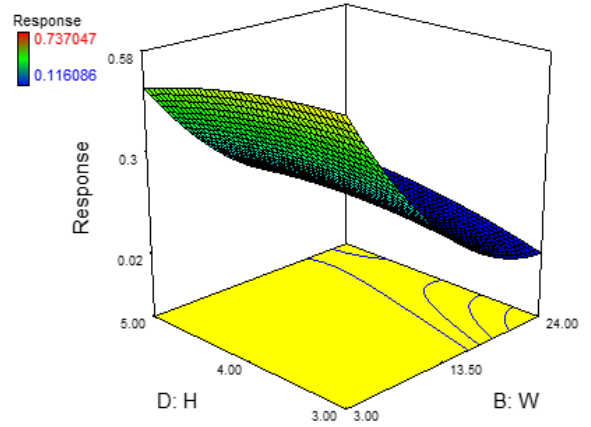

440

(e)

(f)

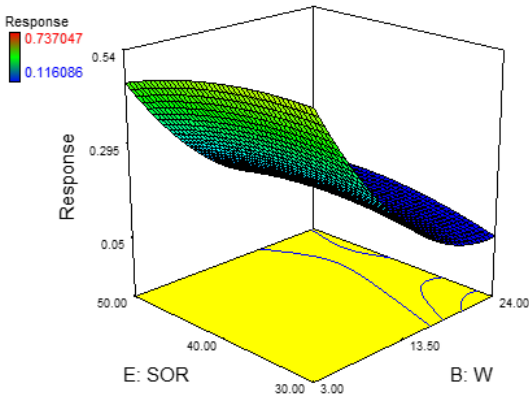

441

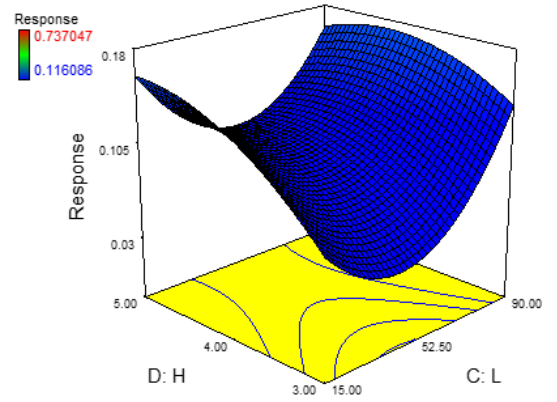

452

(g)

(h)

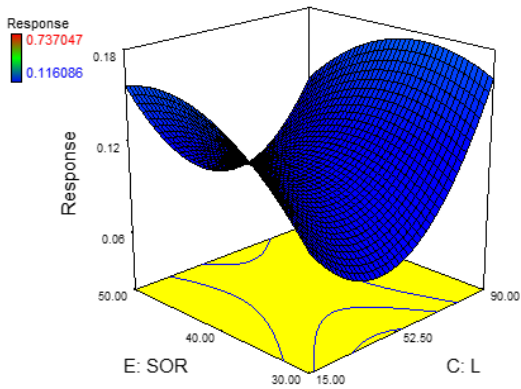

462

(I)

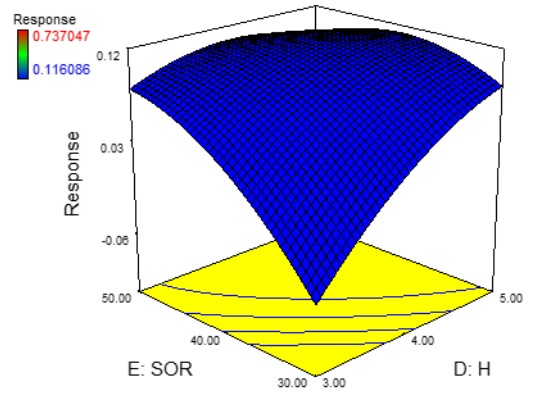

463

(g)

464

Fig.13. Binary sensitivity analysis of effective parameters on the response surface in improve process scenario.



465 The normalization analysis of tests' results in improving process scenarios depicts that products are  
 466 not near the normal line like economic scenario, which means the distribution of the results is abnormal.  
 467 Statistical distribution of tests' outcomes in the CCD-RSM method is reported in Fig.14.

468  
 469  
 470  
 471  
 472

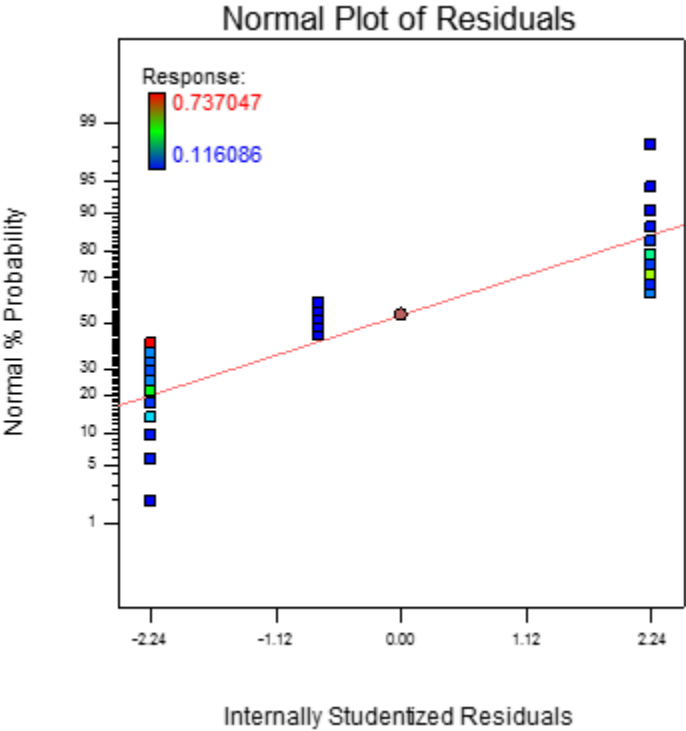

486  
 487  
 488  
 489  
 490  
 491  
 492  
 493  
 494  
 495

**Fig.14. Improve process scenario tests' results distribution compare to the normal curve.**

Optimal results suggested by the CCD-RSM method to minimize the response surface is demonstrated in Table 8. These suggestions should be re-evaluated during the designing process to obtain a final-optimal model. Optimization procedure of improving process scenario in three GA, PSA and SAA computations is illustrated in Fig. 15. In the following, calibrated Equations' error in comparison of experimental values in optimum suggestions based on GA, PSA, SAA and CCD-RSM are summarized in Fig. 16. Likewise, all improving process responses are computed in each method and then, they are appraised with experimental outcomes according to simple absolute distance percentage.

**Table 8. optimal modes predictions in the CCD-RSM method for designing PSTs in improve process scenario.**

Number	n	W	L	H	SOR	Response
1	3.46	20.75	33.5	4.51	35.57	0.104175
2	2.64	17.02	36.99	3.35	36.68	0.076028
3	3.09	16.1	66.36	4.28	42.13	0.095557
4	2.08	18.62	57.7	3.96	40.34	0.084805

496  
497

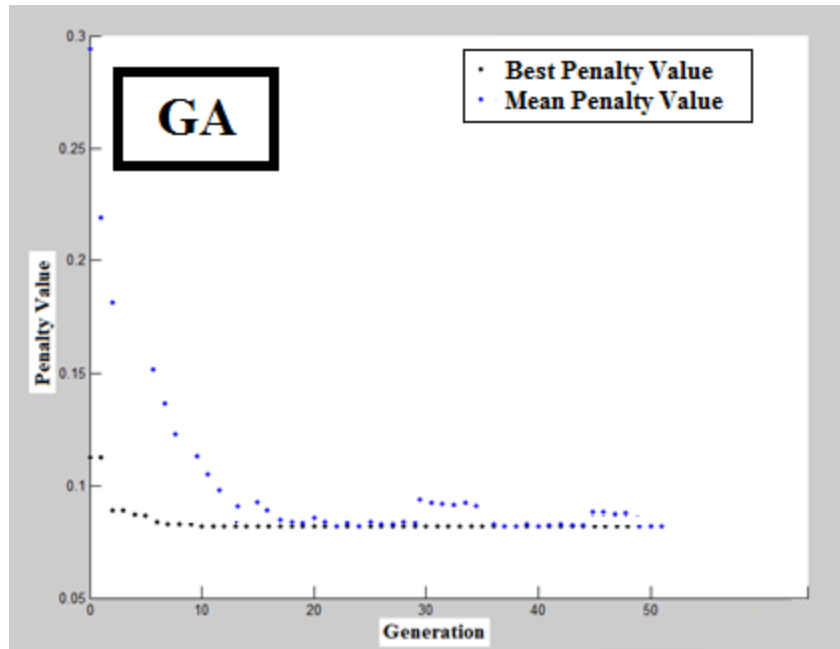

(a)

498  
499

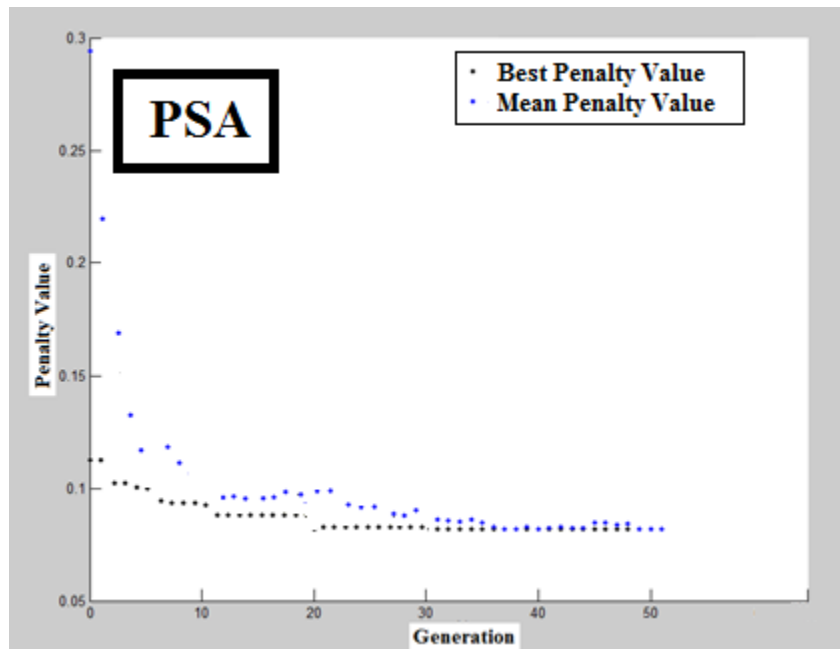

(b)

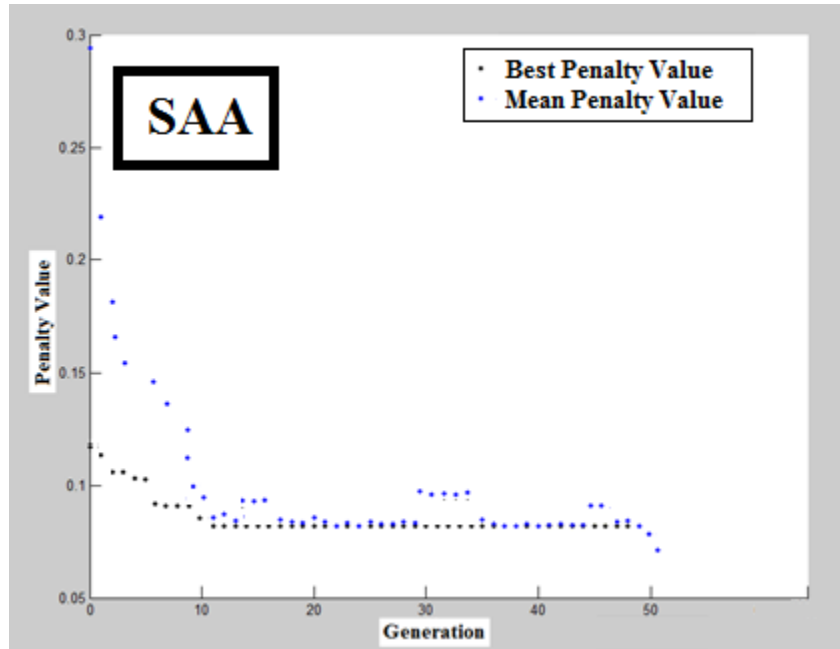

(c)

Fig.15. Calibrating process in improving process scenario with (a) GA, (b) PSA and SAA.

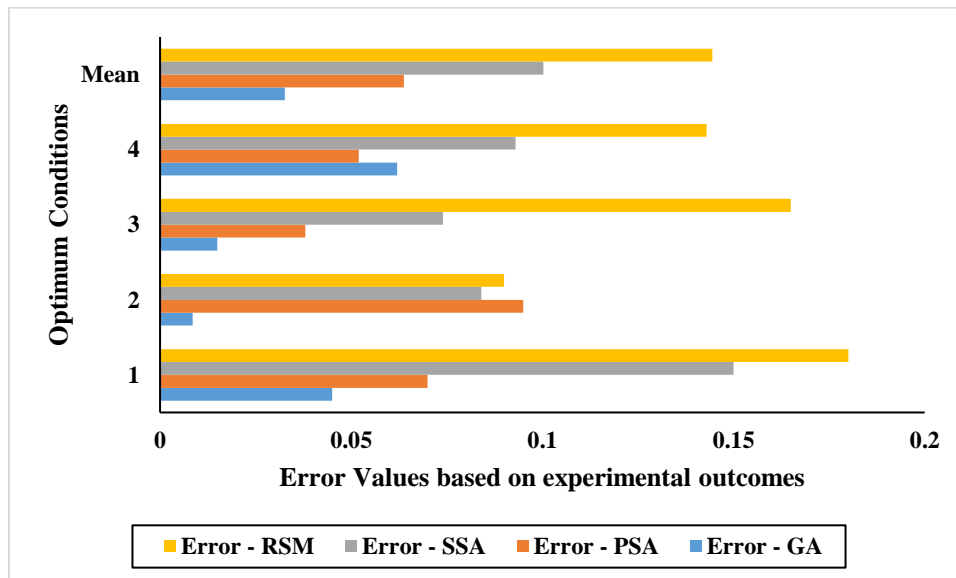

Fig.16. Error values of calibrated Equations in comparison of experimental outcomes in improving process scenario.

As per Fig. 15, in improving process scenario, GA algorithm with 0.032 mean error through all four suggestions results was the best estimation which is illustrated in Equation 9. Likewise, based on Fig. 15, the value of penalty is reduced in different iteration, but, the performance of GA and SAA are more than PSA in improving process scenario which are converged to optimal amount in the minimum time. Besides, with consideration to Fig. 16, performance of GA is better than SAA in error value aspect.

512

**Equation 9**

$$\begin{aligned}
513 \quad \text{Response} = & - 0.205622 + 0.033258 * n - 0.145098 * W - 8.50288E-003 * L + 0.462102 * H \\
514 \quad & + 0.052378 * \text{SOR} + 6.952036E - 003 * n * W + 3.59109E-004 * n * L - 0.038342 * n * H - 2.13657E- \\
515 \quad & 003 * n * \text{SOR} + 3.6352E-004 * W * L + 2.14025E-003 * W * H + 1.59362E-004 * W * \text{SOR} - \\
516 \quad & 7.05899E-004 * L * H - 4.1033052E-005 * L * \text{SOR} - 5.40025E-003 * H * \text{SOR} + 5.3287403E- \\
517 \quad & 003 * n^2 + 3.562188E-003 * W^2 + 5.62189E-005 * L^2 - 0.00985601 * H^2 - 3.25665E004 * \text{SOR}^2
\end{aligned}$$

518



519

520

$$\begin{aligned}
521 \quad \text{Response (Reduced form)} = & - 0.205622 + 0.033258 * n - 0.145098 * W + 0.462102 * H \\
522 \quad & + 0.052378 * \text{SOR} - 0.038342 * n * H - 0.00985601 * H^2
\end{aligned}$$

523

524 In tank efficiency scenario, the product of nine objective function's RDI with their weights  
525 quantities as per CCD-RSM computations in this scenario for each test is shown in Fig.17.

526

527

528

529

530

531

532

533

534

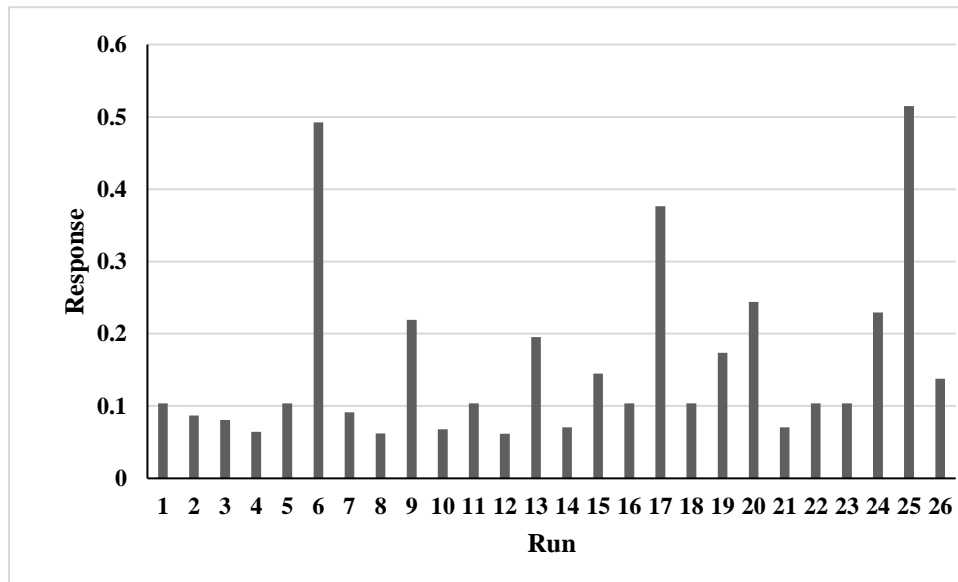

535

536 **Fig.17. Planned tests' results for designing PSTs in the tank efficiency scenario.**

537 Statistical evaluation of input data into the CCD-RSM model and calculating the response surface  
538 (Tank efficiency scenario) in each test has done. The results concluded a quadratic model for predicting the  
539 response surface that is demonstrated in Equation 10.

540

**Equation 10**

$$\begin{aligned}
541 \quad \text{Response} = & + 1.31914 - 0.030572 * n - 0.11141 * W - 0.011485 * L - 0.085569 * H - 5.69808E- \\
542 \quad & 003 * \text{SOR} + 7.76851E - 003 * n * W + 7.90049E-004 * n * L - 0.024440 * n * H - 5.53472E-004 * \\
543 \quad & n * \text{SOR} + 4.49553E-004 * W * L + 7.20194E-003 * W * H + 4.24728E-004 * W * \text{SOR} + \\
544 \quad & 6.51613E-004 * L * H - 8.43560E - 006 * L * \text{SOR} + 2.17595E-003 * H * \text{SOR} + 9.79504E-003 * \\
545 \quad & n^2 + 7.28836E-004 * W^2 + 2.19976E-005 * L^2 - 4.47826E-003 * H^2 - 8.29530E-005 * \text{SOR}^2
\end{aligned}$$

546  
547  
548  
549

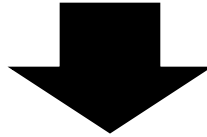

$$\text{Response (Reduced form)} = + 1.31914 - 0.030572 * n - 0.11141 * W - 0.011485 * L - 0.085569 * H + 7.90049E-004 * n * L - 0.024440 * n * H$$

550  
551  
552  
553  
554  
555  
556  
557  
558  
559  
560  
561

ANOVA results and sensitivity evaluation of effective parameters on the response surface in the tank efficiency scenario is reported in Table 9. Results show that Equation four's computational model's P-Value is below 0.0001 and is assured of predicting and optimizing. Moreover, the length (L) and the tank's number (n) factors with the sequential P-Value of 0.0002 and 0.0003 significantly influence the design. After them, the tank's height (H) and the tank's width (W) impact the response surface substantially. While in the economic scenario and the improve process scenario, the width (W) had a significant impact. At the same time, in all three scenarios, geometrical indicators have a very considerable influence on the response surface. Sensitivity analysis and binary analysis of effective parameters on the response surface in the tank efficiency scenario is shown in Fig.18.

562  
563

**Table 9. ANOVA evaluation of effective parameters on the PSTs design in the tank efficiency scenario.**

Source	Sum of Squares	df	Mean Square	F Value	p-value (Prob > F)	
<b>Model</b>	0.391476	20	0.019574	192.413	< 0.0001	significant
<b>A-n</b>	0.008602	1	0.008602	84.55746	0.0003	-
<b>B-W</b>	0.0003	1	0.0003	2.946611	0.1467	-
<b>C-L</b>	0.009511	1	0.009511	93.49107	0.0002	-
<b>D-H</b>	0.001626	1	0.001626	15.98114	0.0103	-
<b>E-SOR</b>	0	1	0	0	1.0000	-
<b>AB</b>	0.011614	1	0.011614	114.1658	0.0001	-
<b>AC</b>	0.001532	1	0.001532	15.06099	0.0116	-
<b>AD</b>	0.001043	1	0.001043	10.24911	0.0240	-
<b>AE</b>	5.35E-05	1	5.35E-05	0.525622	0.5009	-
<b>BC</b>	0.054692	1	0.054692	537.632	< 0.0001	-
<b>BD</b>	0.009982	1	0.009982	98.1206	0.0002	-
<b>BE</b>	0.003472	1	0.003472	34.12573	0.0021	-
<b>CD</b>	0.001042	1	0.001042	10.24529	0.0240	-
<b>CE</b>	1.75E-05	1	1.75E-05	0.171703	0.6958	-
<b>DE</b>	0.000826	1	0.000826	8.124171	0.0358	-
<b>A^2</b>	0.000474	1	0.000474	4.66225	0.0833	-
<b>B^2</b>	0.031918	1	0.031918	313.7623	< 0.0001	-
<b>C^2</b>	0.00473	1	0.00473	46.50066	0.0010	-
<b>D^2</b>	9.91E-05	1	9.91E-05	0.974545	0.3689	-
<b>E^2</b>	0.00034	1	0.00034	3.343859	0.1270	-

<b>Residual</b>	0.000509	5	0.000102	-	-	-
<b>Lack of Fit</b>	0.000509	1	0.000509	-	-	-
<b>Pure Error</b>	0	4	0	-	-	-
<b>Cor Total</b>	0.391984	25	-	-	-	-

564

565

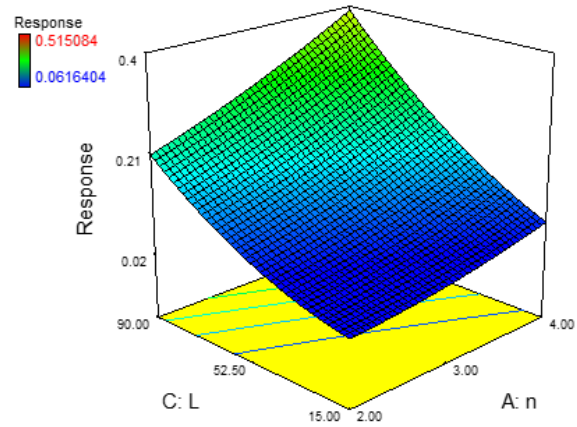
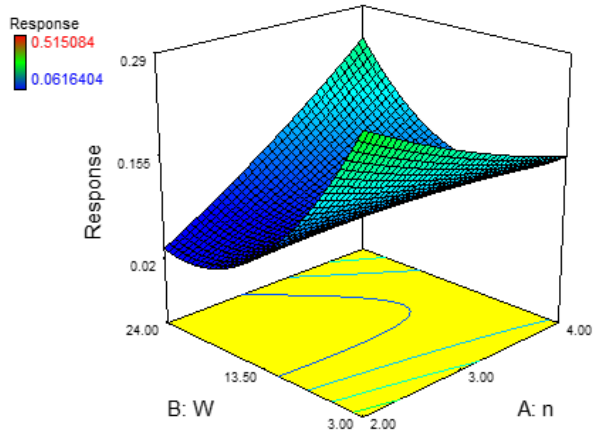

566

567

(a)

(b)

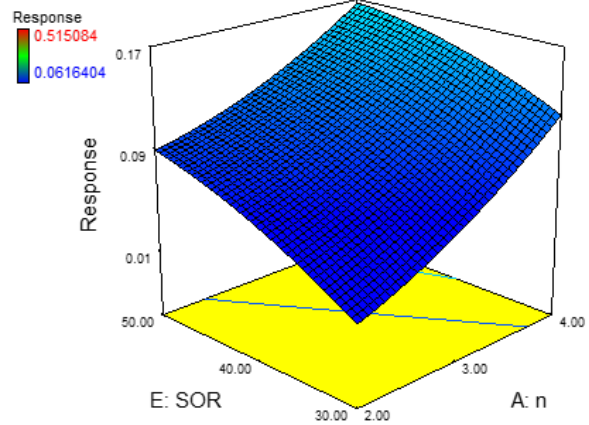
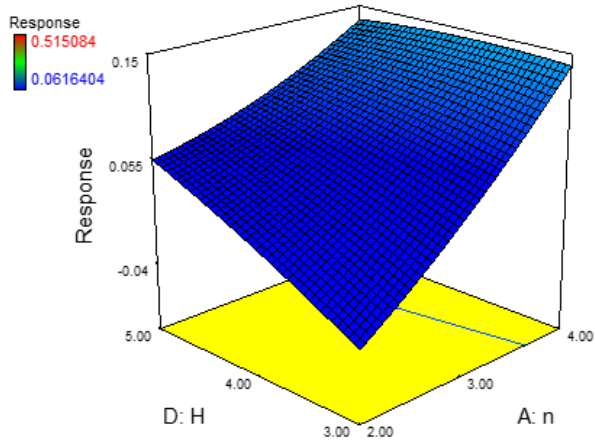

568

569

(c)

(d)

570

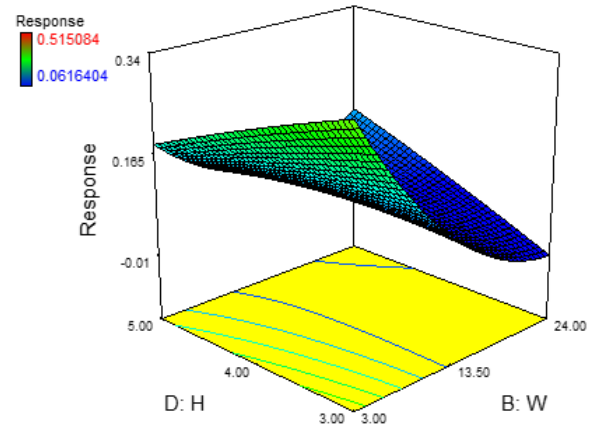
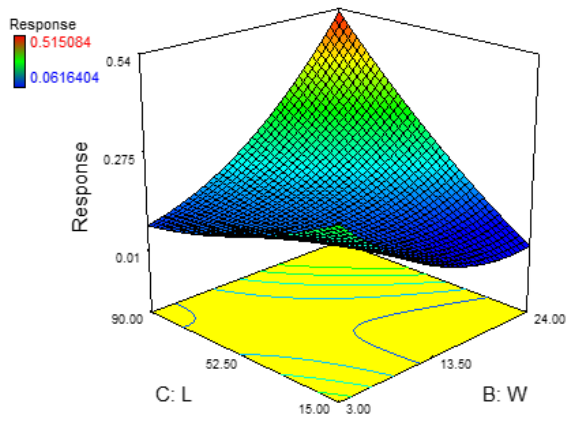

571

572

(e)

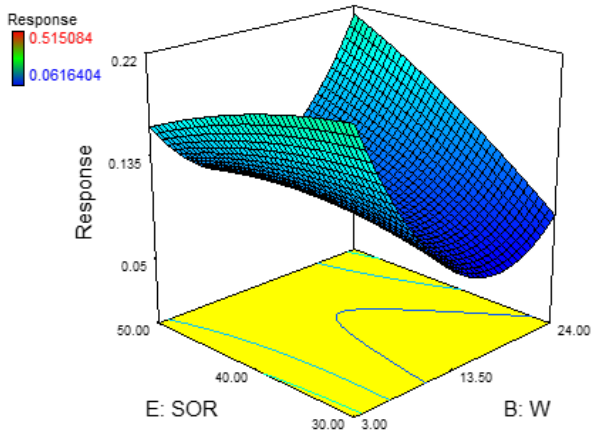

(f)

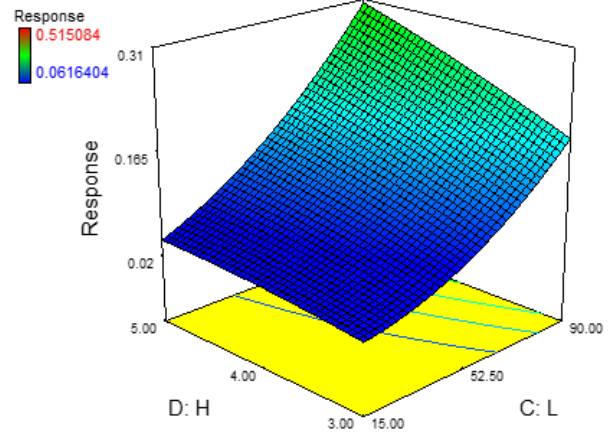

573

(g)

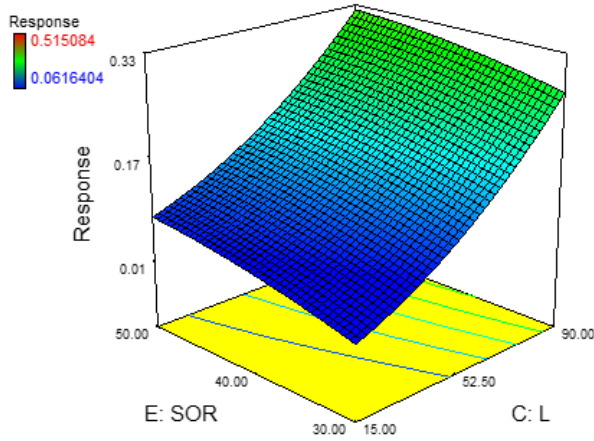

(h)

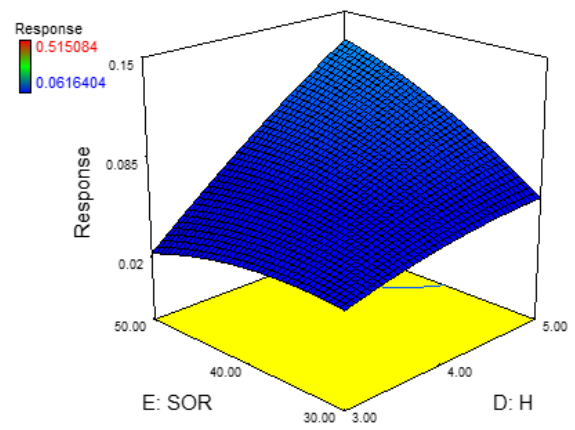

574

575

(i)

(j)

576  
577

**Fig.18. Binary sensitivity analysis of effective parameters on the response surface in the tank efficiency scenario in designing PSTs.**

578 Planned tests response surface distributions in the CCD-RSM method evaluated for being normal,  
579 and the results show the abnormal distribution of output data like both previous scenarios. Statistical data  
580 dispersion and comparing them with the normal line is manifested in Fig.19.

581

582

583

584

585

586

587

588

589

590

591

592

593

594

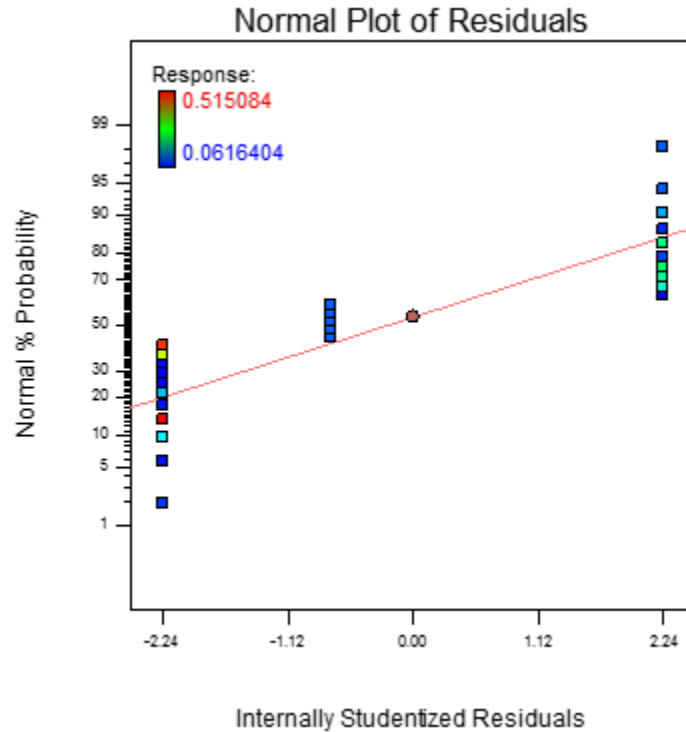

595

**Fig.19. tests' results' distribution in the tank efficiency scenario comparing to the normal line.**

596 At the end of the statistical modelling, the CCD-RSM method's optimal mode suggestions for  
597 minimizing the response surface in the tank efficiency scenario is reported in Table 10. In the following  
598 optimization of computed Equation in tank efficiency scenario in different iterations are presented  
599 according to Fig.20. Also, the error amount of GA, PSA, SAA and CCD-RSM computations are illustrated  
600 based on Fig. 21. According to mentioned Fig., the PSA evolutionary algorithm can enhance accuracy of  
601 Equation in comparison of other ones with 0.063 through all four optimum suggestions in tank efficiency  
602 scenario (Equation 11). **Plus, in the tank efficiency scenario, PSA and SAA are converged to the best  
603 solution in the minimum iterations, but, from error value aspect, PSA has the best efficiency for prediction  
604 of response (Figs. 20 and 21).**

605

### Equation 11

606 **Response** = + 1.31914 - 0.030572\* n - 0.11141\* W - 0.011485\* L - 0.085569\* H - 5.69808E-  
607 003\* SOR+ 7.76851E - 003\* n \* W + 7.90049E-004\* n \* L - 0.024440\* n \* H - 5.53472E-004\*  
608 n \* SOR + 4.49553E-004\* W \* L + 7.20194E-003 \* W \* H + 4.24728E-004\* W \* SOR +  
609 6.51613E-004\* L \* H - 8.43560E - 006\* L \* SOR + 2.17595E-003\* H \* SOR + 9.79504E-003\*  
610 n<sup>2</sup> + 7.28836E-004\* W<sup>2</sup> + 2.19976E-005\* L<sup>2</sup> - 4.47826E-003\* H<sup>2</sup> - 8.29530E-005\* SOR<sup>2</sup>



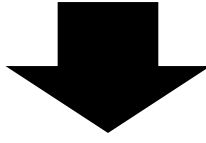

611  
612

613 **Response (Reduced form) = + 1.31914 - 0.030572\* n - 0.11141\* W - 0.011485\* L -**  
614 **0.085569\* H - 0.024440\* n \* H**

615 **Table 10. The CCD-RSM optimal mode suggestions for designing PSTs in tank efficiency scenario.**

Number	n	W	L	H	SOR	Response
1	2.12	15.9	33.27	4.73	35.39	0.04924
2	2.06	17.31	65.07	3.09	44.43	0.009294
3	3.61	3.67	88.45	4.36	49.77	0.042443
4	2.57	19.72	24.96	3.81	41.82	0.002108

616

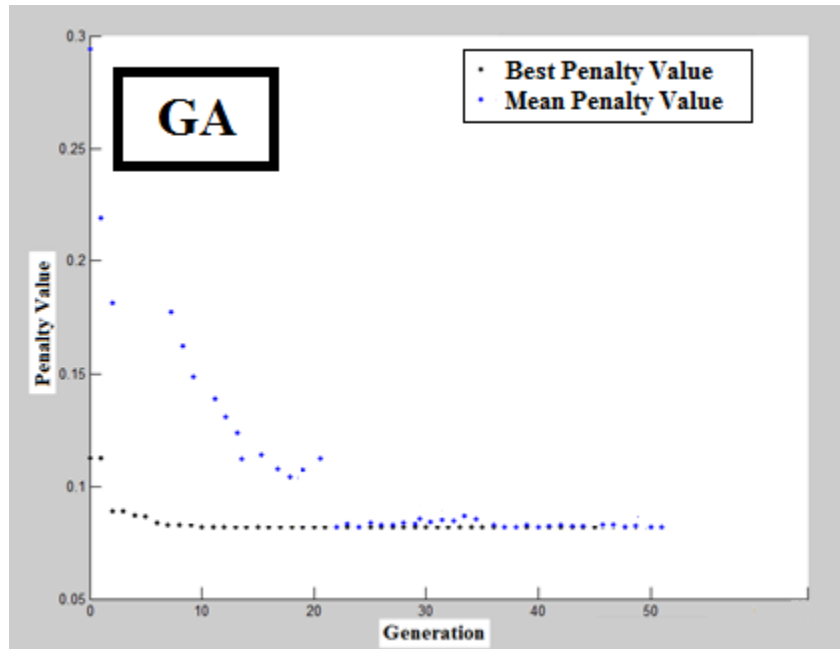

617  
618  
619

(a)

620  
621

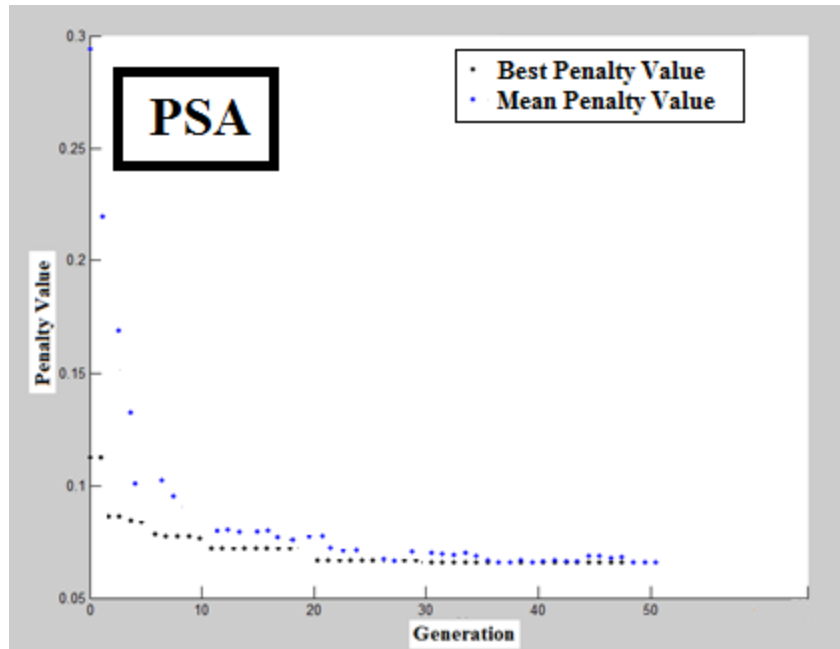

(b)

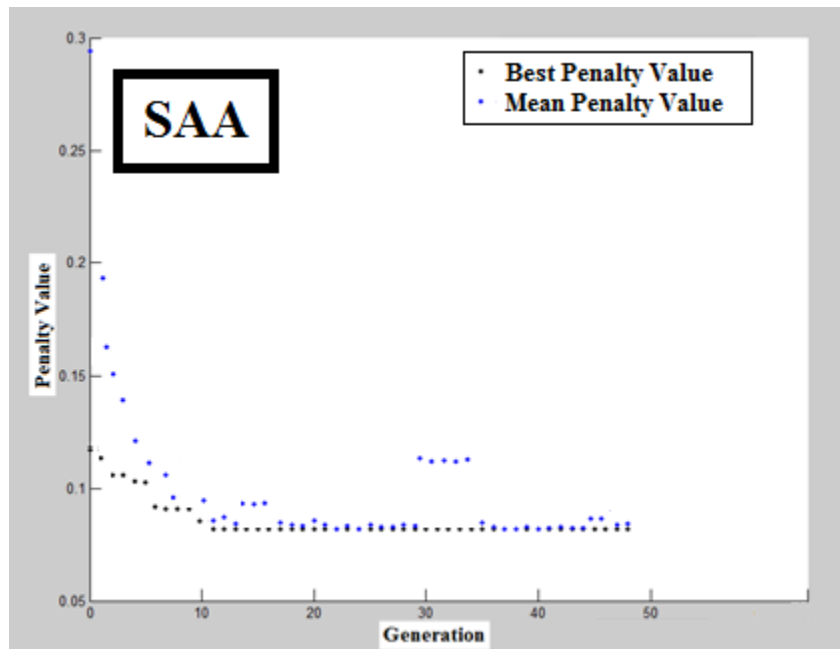

(c)

622  
623  
624

Fig.20. Calibrating process in tank efficiency scenario with (a) GA, (b) PSA and SAA.

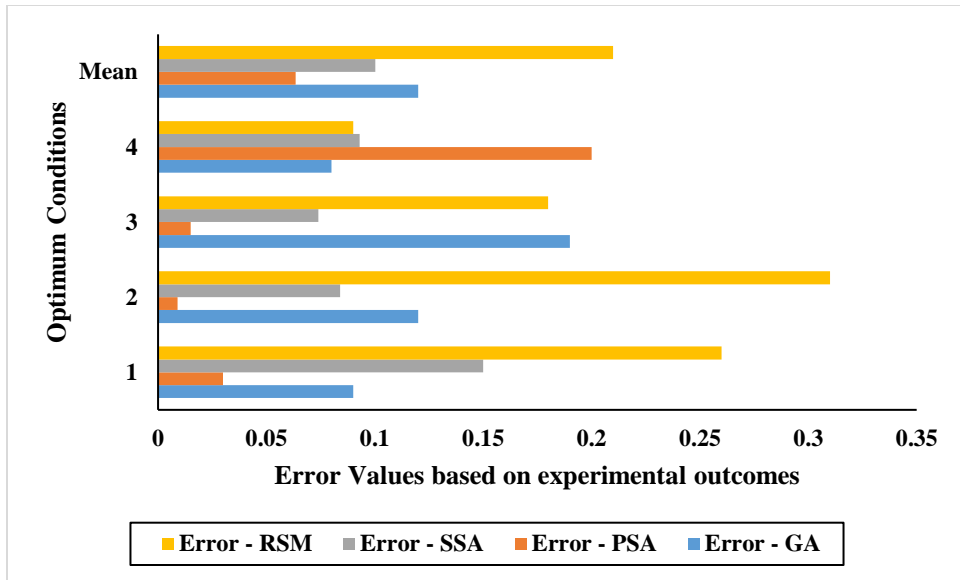

625

626 **Fig.21. Error values of calibrated Equations in comparison of experimental outcomes in tank efficiency**  
 627 **scenario.**

628 At the end of each modelling in three scenarios, suggestions to minimize the response surface was  
 629 determined as per CCD-RSM. In this section, that suggestions will be evaluated to find one specific optimal  
 630 model for each scenario. The CCD-RSM model's suggestions for the economic scenario are again evaluated  
 631 in a programming surface to design PSTs. In the mentioned Scenario, the results of the objective functions  
 632 are demonstrated in Fig.22 and Fig.23. **The function values in the declared Figs are pure amounts of error**  
 633 **functions and they have not any physical meaning.**

634

635

636

637

638

639

640

641

642

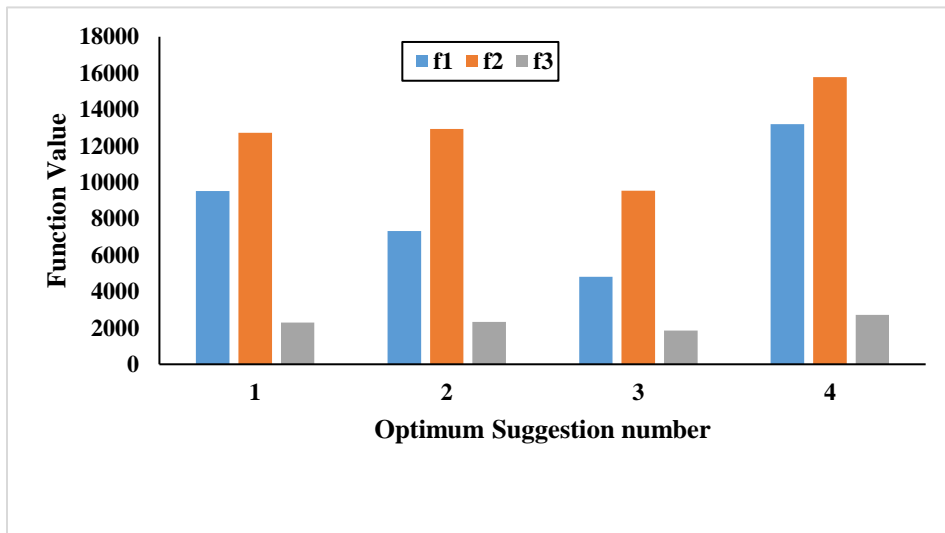

643

**Fig.22. Evaluation of the optimal model in economic scenario as per CCD-RSM (f1-f3).**

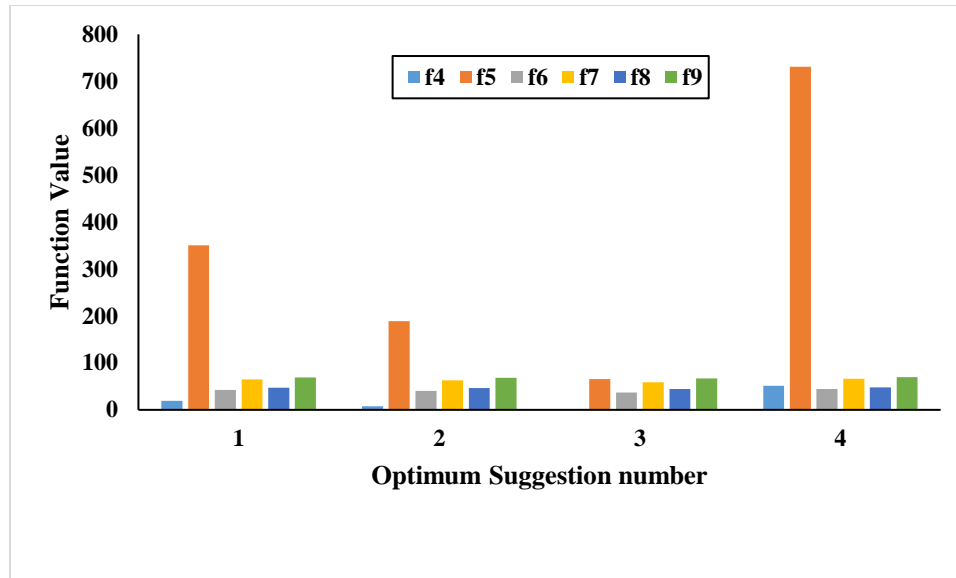

Fig.22. Evaluation of the optimal model in economic scenario as per CCD-RSM (f4-f9).

644

645

646 According to Fig. 22 and 23, the economic function (f1) earned a little weight in the third  
 647 suggestion, because on its importance in economic scenario. Meanwhile, f2-f5 functions gained little  
 648 importance in the third suggestion with more weight value. But it is necessary to say that the desirability of  
 649 f6-f9 procedures is in maximizing the organized data. But in the third suggestion, shown in Table 6, f6-f9  
 650 functions are minimized, which means they have less desirability than the other offers in the tank efficiency  
 651 scenario's indicator. But because of the importance of the economic terms, the number of tanks (n), width  
 652 (W), length (L), height (H), and the SOR parameters are sequentially chosen as 3, 22m, 20m, 3.5m, and 45  
 653  $m^3.m^{-2}.d^{-1}$  in the mentioned planning.

654 Suggested optimal conditions in the CCD-RSM model based on improve process scenario, shown  
 655 in Table 8, has been evaluated. The results of objective functions for the improve process scenario are  
 656 shown in Fig. 24 and 25.

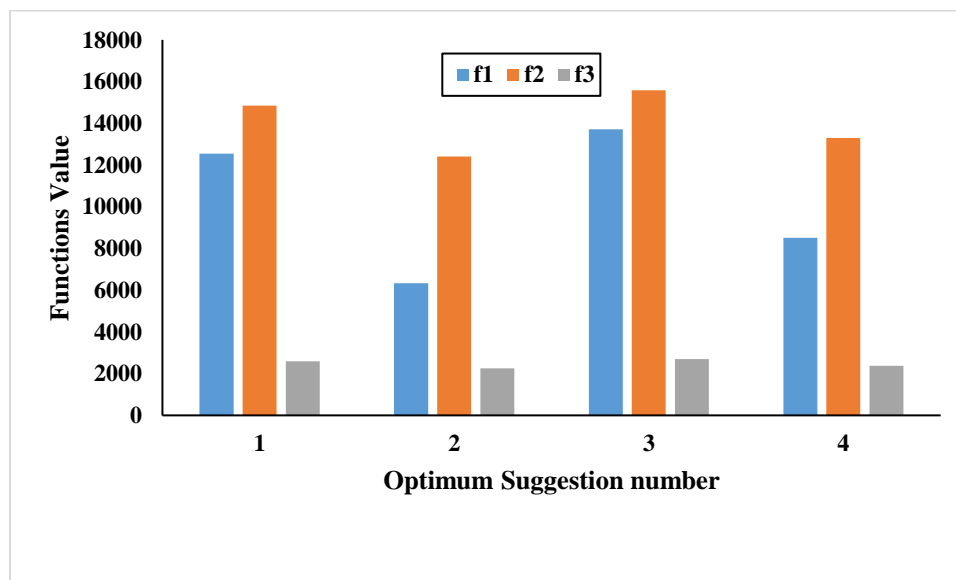

657

658

**Fig.24. Evaluation of the optimal model in improve process scenario as per CCD-RSM (f1-f3).**

659

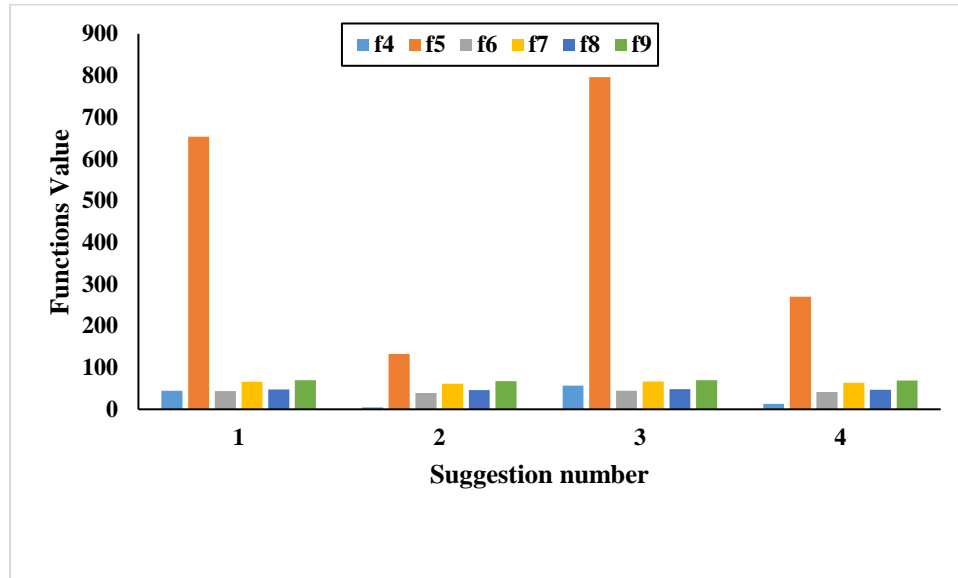

660

**Fig.25. Evaluation of the optimal model in improve process scenario as per CCD-RSM (f4-f9).**

661

662

663 In the improve process scenario, the f2-f5 objective functions should be minimized compared to  
 664 the other suggestions. In the second suggestion, f2-f5 functions are in the minimum condition, which means  
 665 the most desirability in the improve process scenario. In sum, in the improve process scenario, the optimal  
 666 mode of the number of tanks (n), width (W), length (L), height (H), and the SOR factors are sequentially  
 667 taken as 3, 17m, 37m, 3.5m, 36 m<sup>3</sup>.m<sup>-2</sup>. d<sup>-1</sup>.

668 In the tank efficiency scenario, the suggestion of the CCD-RSM model assessed again. The  
 669 evaluation of these suggestions through nine objective functions are shown in Fig. 26 and 27.

670

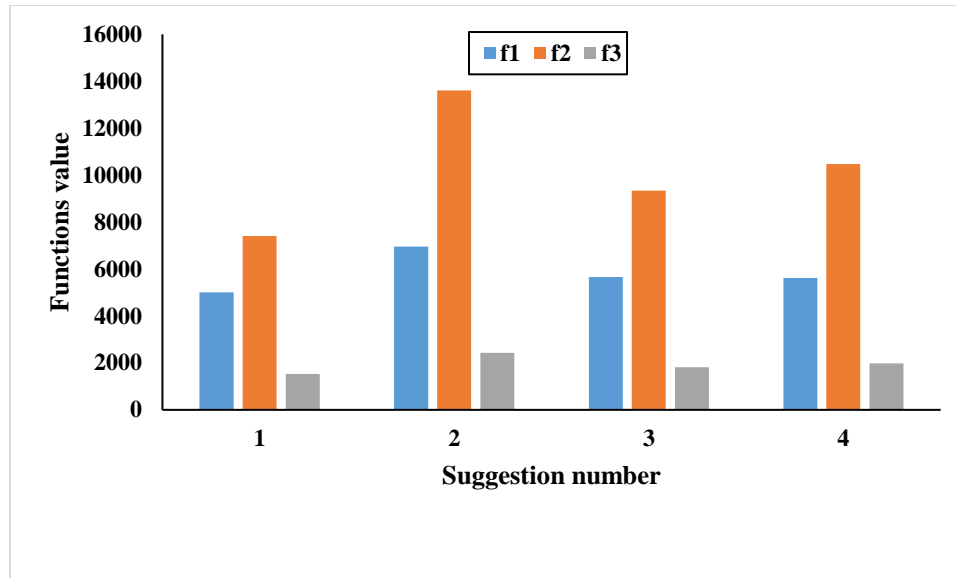

671

672

**Fig.26. Evaluation of the optimal model in tank efficiency scenario as per CCD-RSM (f1-f3).**

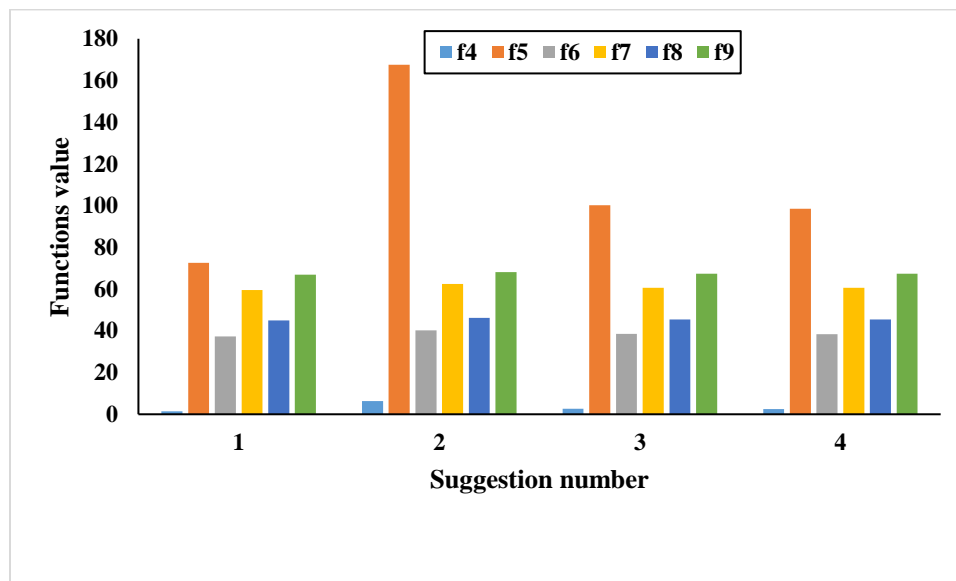

673

674

**Fig.27. Evaluation of the optimal model in tank efficiency scenario as per CCD-RSM (f4-f9).**

675 In the tank efficiency scenario, an appropriate situation occurs when the f6-f9 objective functions  
 676 are minimum. As shown in Fig. 26 and 27, variation of f6-f9 functions in all four suggestions are close to  
 677 each other. In this situation, choosing the optimal mode should be based on the f1-f5 objective functions.  
 678 All the f1-f5 functions are in the type of minimized functions that have the most desirability in the first  
 679 optimal suggestion. In conclusion, the optimal mode of the number of tanks (n), width (W), length (L),  
 680 height (H), and the SOR parameters are sequentially chosen as 2, 16m, 33m, 4.5m, and 35 m<sup>3</sup>.m<sup>-2</sup>. d<sup>-1</sup>.

681 In the last section of study, the efficiency of BOD<sub>5</sub> and TSS removal from optimum conditions in each  
 682 scenario are appraised with experimental practices through the time according to Fig. 28. According to  
 683 mentioned Fig., in tank efficiency scenario, BOD<sub>5</sub> and TSS removal are more than other scenarios and also,  
 684 it is seen that 2-hour RT is the best values for pollution removal from reactor with considering to both BOD<sub>5</sub>

685 and TSS decontamination. By the outcomes of Fig. 28, around 15% of BOD<sub>5</sub> and 20% of TSS are removed  
686 in the designed reactors which illustrates appropriate efficiency.

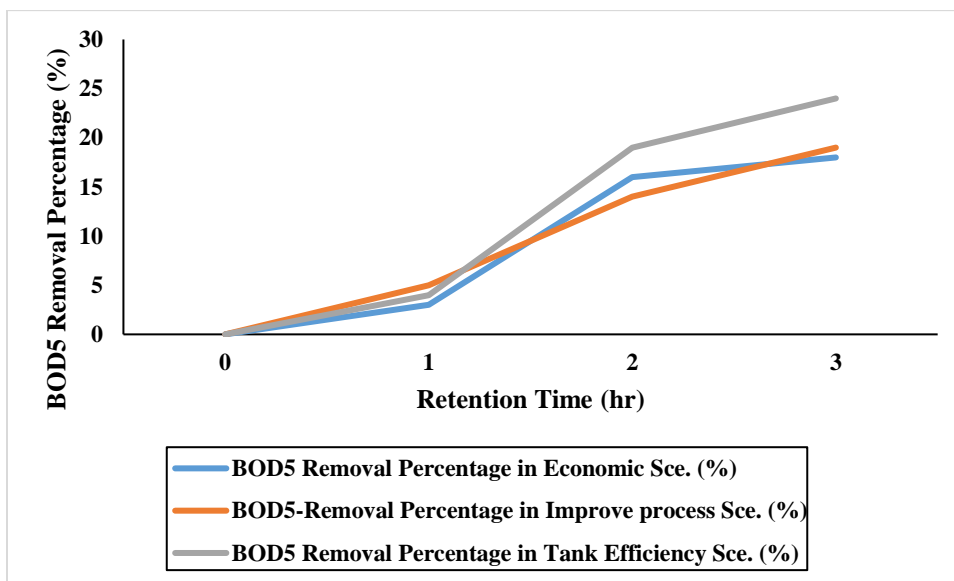

(a)

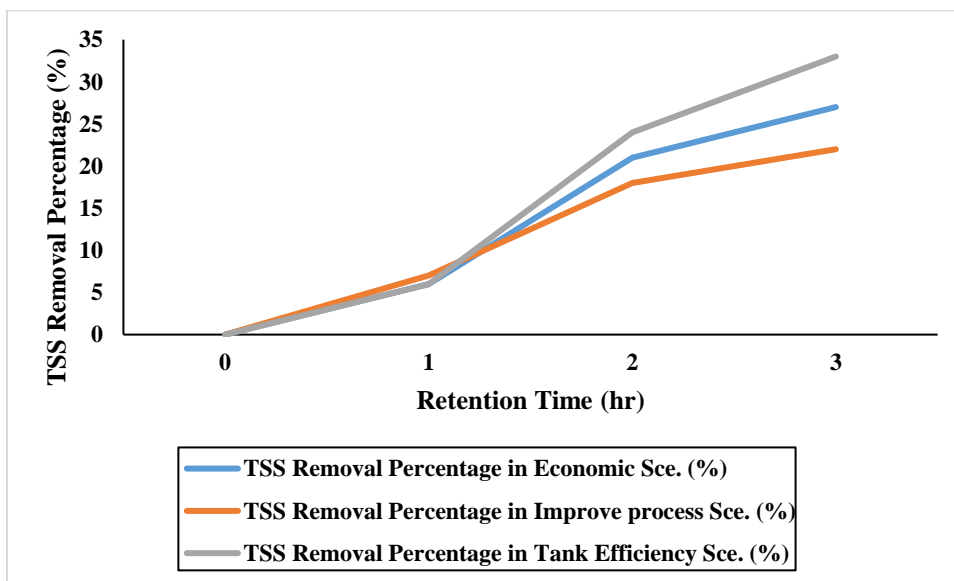

(b)

691 **Fig.28. Retention Time evaluation with focusing on (a) BOD<sub>5</sub> and (b) TSS elimination.**

692 Yaseen. et al. (2021) have evaluated sedimentation process in wastewater treatment plant with considering  
693 experimental practices with and without a baffle. The mentioned investigation results that with baffles, the  
694 efficiency of TSS removal is increased about 34%. Also, they place the baffles based on reactor's length  
695 and depth (Yaseen et al., 2021). In the other same research, Al-Mafraji et al. (2021) have appraised the  
696 efficiency of upper and lower baffles on the PST's performance. In the mentioned study, role of both upper  
697 and lower baffles can be illustrated for damping suspended solids based on hydrodynamic computations

698 (Al-Mafraji et al., 2021). Therefore, evaluation of baffle’s design with combination of RSM and  
 699 evolutionary algorithm can be assumed as future research item.

700 Novikov et al. (2021) have expressed that with injecting finely bubbles in PST, efficiency of the reactors  
 701 can be enhanced around 10% (Novikov et al., 2021). Thus, for future researches, optimizing the spraying  
 702 and aeration processes in PSTs by RSM and metaheuristic can be beneficial. Likewise, based on a research  
 703 item by Leung et al. (2021), application of Cable Driven Parallel Robot (CDPR) for implementation of  
 704 lamella tank can promote performance of PSTs (Leung et al., 2021). So, it can be optimized with RSM and  
 705 meta-heuristic computation as a future research issue.

### 3.2. Managerial insights

707 Reengineering process is so important for from managerial aspects and it is necessary among operation the  
 708 wastewater treatment plants. According to Fig. 29, after sensitive analysis of PSTs based on physical  
 709 specifications, the speed of problem tracking in the mentioned reactors will be simplified. Then, after  
 710 reengineering decision, the optimum values can be determined by integrated CCD-RSM and metaheuristic  
 711 computations as designing environmental supply chain (Chouhan et al., 2021; Mosallanezhad et al., 2021;  
 712 Fasihi et al., 2021; Akbarpour et al., 2021; Zahedi et al., 2021). Whereas, by kinetic evaluation of pollution  
 713 elimination in the designed reactors, operation of wastewater treatment plant can be organized. Finally,  
 714 with the achieved outputs, four stages of PDCA include Plan, Do, Control, and Act are implemented  
 715 through the reengineering procedure (Sadri et al., 2021; Hamdi-Asl et al., 2021; Fasihi et al., 2021).

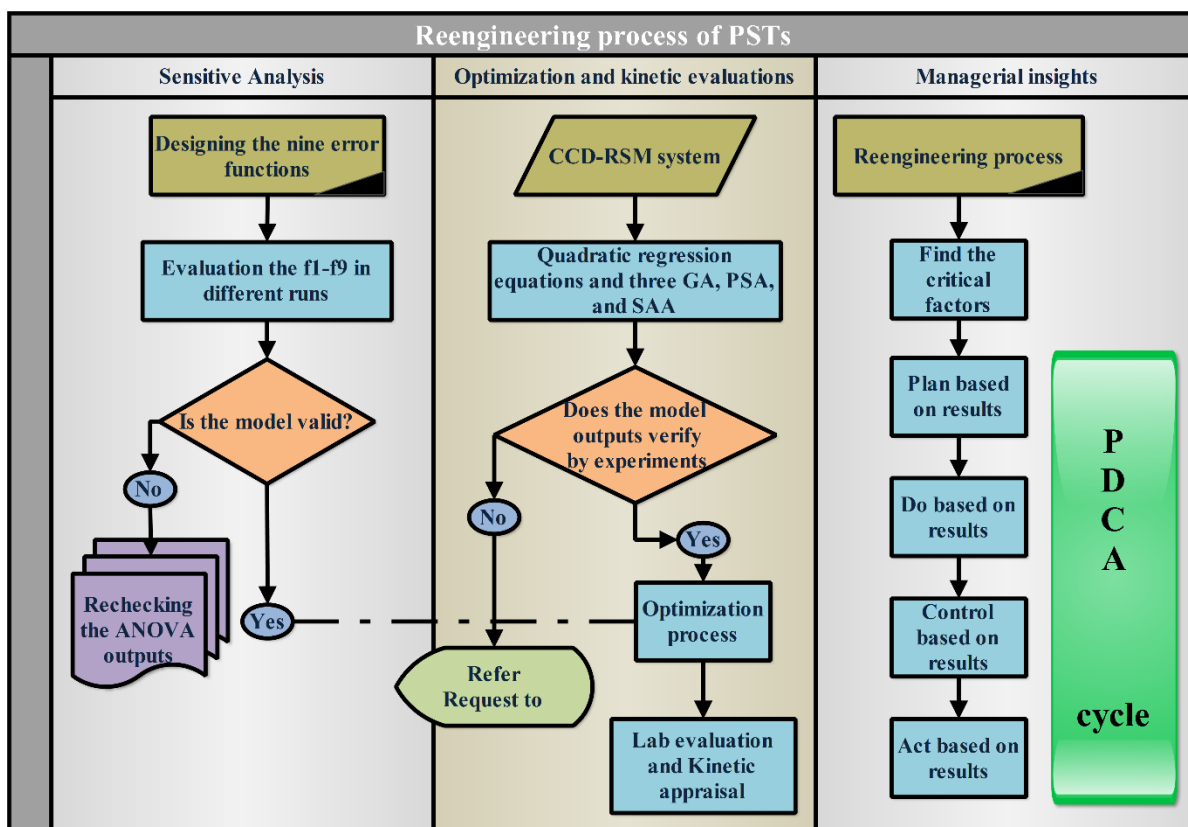

716  
 717 **Fig.29. The conceptual model of PSTs reengineering in the present investigation.**



718

### 3.3. Sustainability

719 The approach of Sustainable Development Goals (SDGs) through the present study as reengineering  
 720 approach is illustrated in Fig. 30. Based on the mentioned Fig., three sections of SDGs include Good Health  
 721 and Well-being (Hosseini et al., 2021), Clean Water and Sanitation (Mousavi et al., 2021), and Sustainable  
 722 Cities and Communities (Salehi-Amiri et al., 2022) are met. With increasing the quality of wastewater  
 723 treatment process, both Clean Water and Sanitation and Good Health and Well-being goals are satisfied ().  
 724 Likewise, the suitable reengineering causes the cost optimization with increasing the efficiency and it is  
 725 directed to Sustainable Cities and Communities (Mosallanezhad et al., 2021). Therefore, the results of  
 726 present study can be met the SDGs in the industrial wastewater treatment plants and by the mentioned  
 727 outputs, the threaten of decontamination process can be converted to opportunity (Fathollahi-Fard et al.,  
 728 2021).



729

730

**Fig. 30. The conceptual model of sustainability through the present study.**

731

732 **3.4. Operational framework**

733 With consideration to outcomes of this study, a conditional framework is presented in different situations  
 734 as per Fig. 31. This created framework shows that through the reengineering the PSTs, different scenarios  
 735 can be implemented and finally, the superposition of all computations in all scenarios is expressed as per  
 736 Fig. 31. Based on the results, in each scenario and according to its priorities, a design pattern is suggested.  
 737 Besides, the mean value of the effective parameters is introduced as the middle level of design factors which  
 738 satisfies all different scenarios.

739

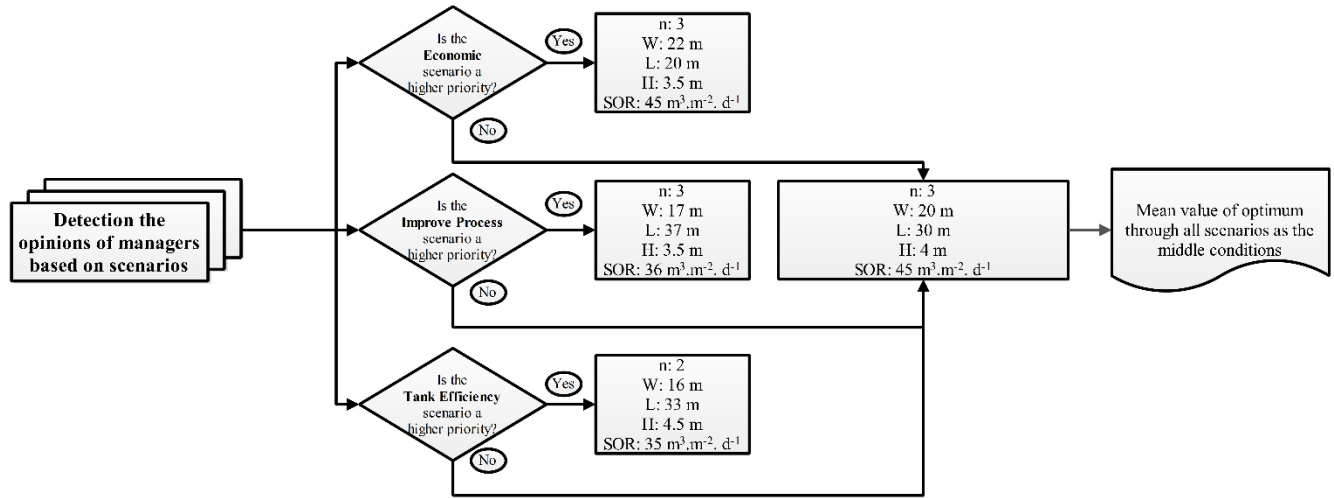

740

741 **Fig.31. The conditional operational framework for PSTs through this research.**

742

743 **4. Conclusion**

744 PSTs have essential role for elimination of fixed and volatile suspended solids in wastewater treatment  
 745 plants. With appropriate designing PST, considerable volume of contaminations can be treated and then,  
 746 operation of biological/chemical process will be easier. In the classical designing methods, all scheming  
 747 parameters are adjusted by try and error in sequential computations loops. In this study, a novel concept for  
 748 designing and reengineering PSTs based on combination of RSM, metaheuristic, SBM and experimental  
 749 efforts is presented. In the first step, computations of PST's are done and the algorithm of design is created.  
 750 Then, the design of experiments is implemented in CCD-RSM as per computational efforts. In the next  
 751 step, all CCD-RSM computations are operated in three scenarios containing economic, improve process  
 752 and tank efficiency with considering to RDI scale less system. Finally, the mentioned prediction Equations  
 753 are calibrated by GA, PSA and SAA as efficient metaheuristics and they are compared with experimental  
 754 outcomes for choosing the best metaheuristic algorithm in each scenario. At the end of research, after  
 755 computing objective functions in all scenarios, BOD<sub>5</sub> and TSS removal are appraised through different RT  
 756 values.

757 The main outcomes of this research are including:

- 758 • Having a comparison among the proposed metaheuristics, PSA, GA and PSA achieved the  
 759 minimum error equal to 0.02, 0.032 and 0.063 in comparison of experimental tests for economic,

- 760 improve process and tank efficiency scenarios, correspondingly, through four CCD-RSM optimum  
 761 suggestions.
- 762 • According to CCD-RSM evaluations, the most effective parameters for economic, improve process  
 763 and tank efficiency scenarios are including W, W and L with 0.0002, 0.0005 and 0.0002 P-Values,  
 764 respectively.
  - 765 • In the economic scenario, the optimum number of tanks (n), width (W), length (L), height (H), and  
 766 the SOR are equal to 3, 22m, 20m, 3.5m, and 45 m<sup>3</sup>.m<sup>-2</sup>. d<sup>-1</sup>, respectively.
  - 767 • In the improve process scenario, the optimum number of tanks (n), width (W), length (L), height  
 768 (H), and the SOR are equal to 3, 17m, 37m, 3.5m, 36 m<sup>3</sup>.m<sup>-2</sup>. d<sup>-1</sup>, respectively.
  - 769 • In the tank efficiency scenario, the optimum number of tanks (n), width (W), length (L), height (H),  
 770 and the SOR are equal to 2, 16m, 33m, 4.5m, and 35 m<sup>3</sup>.m<sup>-2</sup>. d<sup>-1</sup>, respectively.
  - 771 • According to BOD<sub>5</sub> and TSS elimination appraisal during different RT, it can be seen that optimum  
 772 RT is equal to 2 hr.

773 At last but not least, the main future research direction is to apply other metaheuristics especially novel  
 774 metaheuristics like red deer algorithm (Fathollahi-Fard et al., 2020c) and social engineering optimizer  
 775 (Fathollahi-Fard et al., 2018) and Keshtel algorithm (Fathollahi-Fard et al., 2021) etc.

776

777

778

## 779 **References**

780 Akbarpour, N., Salehi-Amiri, A., Hajiaghaei-Keshteli, M., & Oliva, D., 2021. An innovative waste  
 781 management system in a smart city under stochastic optimization using vehicle routing problem. *Soft*  
 782 *Comput*, 25(8), 6707-6727.

783 Aleksendrić, D. and Carlone, P., 2015. Composite materials–modelling prediction and optimization.  
 784 In *Soft Computing in the Design and Manufacturing of Composite Materials* (pp. 61-289). Elsevier.

785 Al-Mafraji, E.A. and Al-Mussawy, H.A., 2021, February. Using lower and upper baffle arrangements  
 786 to enhance sedimentation tank performance. In *IOP Conference Series: Materials Science and Engineering*  
 787 (Vol. 1067, No. 1, 012009). IOP Publishing.

788 Benefield, L.D., Judkins, J.F. and Parr, A.D., 1984. *Treatment plant hydraulics for environmental*  
 789 *engineers* (pp. 108-122). Englewood Cliffs, New Jersey: Prentice-Hall.

790 Bustos, M.C., Tory, E.M., Bürger, R. and Concha, F., 1999. *Sedimentation and thickening:*  
 791 *Phenomenological foundation and mathematical theory* (Vol. 8). Springer Science & Business Media.

792 Chouhan, V. K., Khan, S. H., & Hajiaghaei-Keshteli, M., 2021. Metaheuristic approaches to design  
 793 and address multi-echelon sugarcane closed-loop supply chain network. *Soft Comput*, 25(16), 11377-  
 794 11404.

795 Christoulas, D.G., Yannakopoulos, P.H. and Andreadakis, A.D., 1998. An empirical model for  
 796 primary sedimentation of sewage. *Environ. Int.*, 24(8), 925-934.

797 Concha, F. and Bürger, R., 2002. A century of research in sedimentation and thickening. *KONA*  
 798 *Powder Part. J.*, 20, 38-70.

799 Edwards, J.D., 2019. *Industrial Wastewater Treatment*. CRC press.

800 Eftekhari, M., Akrami, M., Gheibi, M., Azizi-Toupkanloo, H., Fathollahi-Fard, A.M. and Tian, G.,  
801 2020. Cadmium and copper heavy metal treatment from water resources by high-performance folic acid-  
802 graphene oxide nanocomposite adsorbent and evaluation of adsorptive mechanism using computational  
803 intelligence, isotherm, kinetic, and thermodynamic analyses. *Environ. Sci. Pollut. Res.*, 27(35), 43999-  
804 44021.

805 Eftekhari, M., Gheibi, M., Azizi-Toupkanloo, H., Hossein-Abadi, Z., Khraisheh, M., Fathollahi-Fard,  
806 A.M. and Tian, G., 2021. Statistical optimization, soft computing prediction, mechanistic and empirical  
807 evaluation for fundamental appraisal of copper, lead and malachite green adsorption. *J. Ind. Inf. Integr.*, 23,  
808 100219.

809 Erfani, S.M.H., Danesh, S., Karrabi, S.M., Gheibi, M. and Nemati, S., 2019. Statistical analysis of  
810 effective variables on the performance of waste storage service using geographical information system and  
811 response surface methodology. *J. Environ. Manag.*, 235, 453-462.

812 Fasihi, M., Tavakkoli-Moghaddam, R., Najafi, S. E., & Hajiaghahi-Keshteli, M., 2021. Developing a  
813 Bi-objective Mathematical Model to Design the Fish Closed-loop Supply Chain. *Int J Eng*, 34(5), 1257-  
814 1268.

815 Fasihi, M., Tavakkoli-Moghaddam, R., Najafi, S. E., & Hajiaghahi, M., 2021. Optimizing a bi-  
816 objective multi-period fish closed-loop supply chain network design by three multi-objective meta-heuristic  
817 algorithms. *Scientia Iranica*, In press.

818 Fathollahi-Fard, A. M., Ahmadi, A., & Mirzapour Al-e-Hashem, S. M. J., 2020a. Sustainable Closed-  
819 loop Supply Chain Network for an Integrated Water Supply and Wastewater Collection System under  
820 Uncertainty, *J. Environ. Manag.*, 275, 111277.

821 Fathollahi-Fard, A. M., Hajiaghahi-Keshteli, M., Tavakkoli-Moghaddam, R., & Smith, N. R., 2021.  
822 Bi-level programming for home health care supply chain considering outsourcing. *J Ind Inf Integr*, 100246.

823 Fathollahi-Fard, A. M., Hajiaghahi-Keshteli, M., Tian, G., & Li, Z. 2020b. An adaptive Lagrangian  
824 relaxation-based algorithm for a coordinated water supply and wastewater collection network design  
825 problem. *Inf. Sci.* 512, 1335-1359.

826 Fathollahi-Fard, A. M., Hajiaghahi-Keshteli, M. & Tavakkoli-Moghaddam, R., 2020c. Red deer  
827 algorithm (RDA): a new nature-inspired meta-heuristic, *Soft Comput.*, 24, 14637-14665.

828 Fathollahi-Fard, A. M., Hajiaghahi-Keshteli, M. & Tavakkoli-Moghaddam, R., 2018. The social  
829 engineering optimizer (SEO). *Eng. Appl. Artif. Intell.*, 72, 267-293.

830 Fathollahi-Fard, A. M., Woodward, L., & Akhrif, O. 2021. Sustainable distributed permutation flow-  
831 shop scheduling model based on a triple bottom line concept. *Journal of Ind. Inf. Integ.*, 100233.

832 Ghadami, N., Gheibi, M., Kian, Z., Faramarz, M.G., Naghedi, R., Eftekhari, M., Fathollahi-Fard,  
833 A.M., Dulebenets, M.A. and Tian, G., 2021. Implementation of solar energy in smart cities using an  
834 integration of artificial neural network, photovoltaic system and classical Delphi methods. *Sustain. Cities*  
835 *Soc.*, 103149.

836 Gheibi, M., Karrabi, M. and Eftekhari, M., 2019. Designing a smart risk analysis method for gas  
837 chlorination units of water treatment plants with combination of Failure Mode Effects Analysis, Shannon  
838 Entropy, and Petri Net Modeling. *Ecotoxicol. Environ. Saf.*, 171, 600-608.

839 Gheibi, M., Pouresmaeil, H., Akrami, M., Kian, Z., Takhtravan, A. and Mohammadi, M., 2021.  
840 Presenting a novel approach for designing chlorine contact reactors by combination of genetic algorithm  
841 with nonlinear condition functions, simulated annealing algorithm, pattern search algorithm and  
842 experimental efforts. *Annals Environ. Sci. Toxic.*, 5(1), 012-017.

843 Goula, A.M., Kostoglou, M., Karapantsios, T.D. and Zouboulis, A.I., 2008. A CFD methodology for  
844 the design of sedimentation tanks in potable water treatment: Case study: The influence of a feed flow  
845 control baffle. *Chem. Eng. J.*, 140(1-3), 110-121.

846 Henze, M., van Loosdrecht, M.C., Ekama, G.A. and Brdjanovic, D. eds., 2008. *Biological wastewater*  
847 *treatment*. IWA publishing.

848 Hosseini, S. M., Paydar, M. M., & Hajiaghahi-Keshteli, M., 2021. Recovery solutions for ecotourism  
849 centers during the Covid-19 pandemic: Utilizing Fuzzy DEMATEL and Fuzzy VIKOR methods. *Expert*  
850 *Syst Appl*, 185, 115594.

851 Jover-Smet, M., Martín-Pascual, J. and Trapote, A., 2017. Model of suspended solids removal in the  
852 primary sedimentation tanks for the treatment of urban wastewater. *Water*, 9(6), 448.

853 Karia, G.L. and Christian, R.A., 2013. *Wastewater treatment: Concepts and design approach*. PHI  
854 Learning Pvt. Ltd.

855 Kirishima, Y., Choeisai, P., Khotwieng, W., Hatamoto, M., Watari, T., Choeisai, K., Panchaban, P.,  
856 Wong-Asa, T. and Yamaguchi, T., 2021. Efficiency of high rate treatment of low-strength municipality  
857 sewage by a pilot-scale combination system of a sedimentation tank and a down-flow hanging sponge  
858 reactor. *Environ. Technol.*, 1-10.

859 Leung, C.M., Lam, W.Y., Kwok, C.K. and Lau, D., 2021, July. Real-World Development of a  
860 Cleaning CDPR for Primary Lamella Sedimentation Tanks. *Inter. Conf. Cable-Driven Parall. Robots (401-*  
861 *412)*. Springer, Cham.

862 Metcalf, L., Eddy, H.P. and Tchobanoglous, G., 1991. *Wastewater engineering: treatment, disposal,*  
863 *and reuse (Vol. 4)*. New York: McGraw-Hill.

864 Moosavi, J., Naeni, L. M., Fathollahi-Fard, A. M., & Fiore, U. 2021. Blockchain in supply chain  
865 management: a review, bibliometric, and network analysis. *Environ. Sci. Pollut. Res.*, 1-15.

866 Mousavi, R., Salehi-Amiri, A., Zahedi, A., & Hajiaghahi-Keshteli, M., 2021. Designing a supply chain  
867 network for blood decomposition by utilizing social and environmental factor. *Comput Ind Eng*, 160,  
868 107501.

869 Mujeriego, R., and Asano, T., 1999. The role of advanced treatment in wastewater reclamation and  
870 reuse. *Water Sci. Technol.*, 40(4-5), 1-9.

871 Novikov, A.E., Filimonov, M.I., Khadzhide, A.E. and Dugin, E.A., 2021, June. Development and  
872 simulation of the operation of a two-tier sedimentation tank for urban wastewater treatment. In *IOP*  
873 *Conference Series: Earth Environ. Sci.* (Vol. 786, No. 1, 012033). IOP Publishing.

874 Polorigni, C.L., Ikumi, D.S. and Ekama, G.A., 2021. Primary sedimentation modelling with  
875 characterized settling velocity groups. *Water Res.*, 189, 116621.

876 Russell, D.L., 2019. *Practical wastewater treatment*. John Wiley & Sons.

877 Sadri, E., Harsej, F., Hajiaghahi-Keshteli, M., & Siyahbalaii, J., 2021. Evaluation of the components  
878 of intelligence and greenness in Iranian ports based on network data envelopment analysis (DEA)  
879 approach. *J Model Manag.*, In press.

880 Salehi-Amiri, A., Zahedi, A., Gholian-Jouybari, F., Calvo, E. Z. R., & Hajiaghahi-Keshteli, M., 2022.  
881 Designing a Closed-loop Supply Chain Network Considering Social Factors; A Case Study on Avocado  
882 Industry. *Appl Math Model*, 101, 600-631.

883 Sher, F., Hanif, K., Iqbal, S.Z. and Imran, M., 2020. Implications of advanced wastewater treatment:  
884 Electrocoagulation and electroflocculation of effluent discharged from a wastewater treatment plant.  
885 J. Water Process Eng., 33, 101101.

886 Shahrokhi, M., Rostami, F., Md Said, M.A., Sabbagh Yazdi, S.R. and Syafalni, S., 2013.  
887 Computational investigations of baffle configuration effects on the performance of primary sedimentation  
888 tanks. Water and Environ. J., 27(4), 484-494.

889 Shahrokhi, M., Rostami, F., Said, M.A.M., Sabbagh-Yazdi, S.R., Syafalni, S. and Abdullah, R., 2012.  
890 The effect of baffle angle on primary sedimentation tank efficiency. Can. J. Civ. Eng., 39(3), 293-303.

891 Tchobanoglous, G., Burton, F.L. and Stensel, H.D., 2003. Metcalf & Eddy wastewater engineering:  
892 treatment and reuse. International Edition. McGrawHill, 4, 361-411.

893 Vahidifar, S., Saffarian, M.R. and Hajidavalloo, E., 2018. Introducing the theory of successful settling  
894 in order to evaluate and optimize the sedimentation tanks. Meccanica, 53(14), 3477-3493.

895 Vesilind, P. ed., 2003. Wastewater treatment plant design (Vol. 2). IWA publishing.

896 Xu, D., Liu, J., Ma, T., Gao, Y., Zhang, S. and Li, J., 2021. Rapid granulation of aerobic sludge in a  
897 continuous-flow reactor with a two-zone sedimentation tank by the addition of dewatered sludge. J. Water  
898 Process Eng., 41, 101941.

899 Yaseen, D.A., Abu-Alhail, S. and Mohammed, R.N., 2021. An experimental sedimentation tank for  
900 enhancing the settling of solid particles. J. Water Land Develop. In press.

901 Zahedi, A., Salehi-Amiri, A., Hajiaghaei-Keshteli, M., & Diabat, A., 2021. Designing a closed-loop  
902 supply chain network considering multi-task sales agencies and multi-mode transportation. Soft Comput,  
903 25(8), 6203-6235.

904

905

906

907

908

909