



**University of Bergamo**

**Doctoral School in Human Capital Formation and Labor Relations**

**XXVIII Cycle**

*An Empirical Analysis of the Workings of Entrepreneurship,  
and the Role of Entrepreneurship Education on Intention  
towards Entrepreneurship: Insights from Africa*

*Candidate: Habtamu Legas*  
*[Habtamu.legas@unibg.it](mailto:Habtamu.legas@unibg.it)*

*Tutor: Lilli Casano (PhD)*

*[Lilli.casano@adapt.it](mailto:Lilli.casano@adapt.it)*

*Date: 10/01/2016*

In loving memory of my father  
Adane Legas

## Acknowledgement

This dissertation would not have been possible without the help of so many people in so many ways next to the Almighty God and the mother of all mothers, Virgin Mary.

I would like to extend my deepest gratitude to my tutor Doctor Lilli Casano for her full support, active expertise guidance, mentorship, understanding and encouragement throughout my study. Without her incredible patience and timely wisdom and counsel, I would not have made headway in this work.

I am also ineffably indebted to Professor Michele Tiraboschi for giving me this opportunity, and the inspiration during the term of my candidature.

Finally, I would like to thank my family and friends for the unconditional love and support during the last three years. Most importantly, I want to thank my wife, Yemisrach Getachew, who always stood by me in good and difficult times and created an atmosphere of love and care that facilitated the progress of this study.

# Table of Contents

Acknowledgement .....	i
List of Figures .....	v
List of Tables .....	v
Abstract .....	vii
I. Introduction.....	1
Chapter 1:Individual Determinants of Entrepreneurship in Africa: Analysis Based on GEM Data .....	6
1. Introduction.....	6
2. Descriptive Statistics.....	8
3. Hypotheses Testing.....	20
4. Concluding Remarks.....	24
Chapter 2: Assessment of the Prevailing Business Climate in Sub-Saharan Africa: A Comparative Analysis.....	26
2.1. Introduction.....	26
2.2. Regulation .....	27
2.2.1. Corruption .....	27
2.2.2. High Tax rate.....	29
2.2.3. Cost of Income .....	31
2.2.4. Getting Credit.....	33
2.2.5. Resolving Insolvency .....	33
2.3. Infrastructure .....	34
2.4. Finance .....	35
2.5. Entrepreneurial Knowledge and Skills .....	37
2.6. Market Size .....	39
2.7. Concluding Remarks.....	39
Chapter 3:The Role of Entrepreneurship Education on Intention towards Entrepreneurship .....	42
3.1. Introduction.....	42
3.2. Data and Methods .....	45
3.2.1. Sample Description.....	45
3.2.2. Questionnaire Development.....	47

3.2.3. Operationalization of the Constructs .....	48
3.2.3.1. The Independent Constructs.....	49
3.2.3.2 The Dependent Construct.....	53
3.2.3.3. Control Variables .....	55
3.2.4. Data Collection Procedure .....	56
3.2.5. Data Analysis Procedure.....	57
3.2.6. Pre-analysis Test .....	58
3.2.6.1. Check for Biases .....	58
3.2.6.2. Tests of Variables.....	59
3.2.6.3. Validation of the Measurement Scale .....	61
3.3. Results and Discussion .....	68
3.3.1. Descriptive Analysis of the Data .....	69
3.3.1.1. Characteristics of the Participants .....	69
3.3.1.2. The Effect of Demographic Variables on Students' Perception to Entrepreneurship.....	75
3.3.2. Hypotheses Testing.....	84
3.3.2.1. Structural Equation Modeling (SEM) .....	84
3.3.2.2. Testing the Relationship between Entrepreneurship Education and Intention to Entrepreneurship: Difference-in-Difference Approach.....	92
3.4. Conclusion and Implications of the Study .....	97
Literature Review.....	104
Chapter 1: An Overview of Entrepreneurship Scene.....	104
1.1. Introduction.....	104
1.1.1. The Concept of Entrepreneurship .....	104
1.2. Individual Determinants of Entrepreneurship.....	113
1.2.1. Gender.....	113
1.2.2. Age .....	115
1.2.3. Education Level .....	117
1.2.4. Working Status.....	120
1.2.5. Income Status .....	121
1.2.6. Self-Assessed Business Skills .....	122
1.2.7. Social Ties .....	123
1.2.8. Fear of Failure .....	125
Chapter 2: Entrepreneurship and the Prevailing Business Environment .....	126
2.1. Introduction.....	126

2.2. Business Regulation.....	126
2.3. Lack of Finance.....	129
2.4. Poor Infrastructure .....	130
2.5. Entrepreneurial Knowledge and Skills .....	131
2.6. Market Size .....	132
Chapter 3: The Role of Entrepreneurship Education on the Intention towards Entrepreneurship .....	134
3.1.Introduction.....	134
3.1.1. Concept of Entrepreneurship Education.....	134
3.1.2. Assessment of Entrepreneurship Education Impact Studies, and Subsequent Research Gaps.....	139
3.2.Theoretical Framework and Research Hypotheses.....	147
3.2.1.Entrepreneurship Intention Theories.....	147
3.2.2.Intention Models .....	151
3.2.2.1. Entrepreneurial Event Model (EEM).....	152
3.2.2.2. Entrepreneurial Intention Model (EIM) and the Revised EIM .....	155
3.2.2.3. Theory of Planned Behavior (TPB) .....	158
3.2.3.Discussion and Selection of Theoretical Framework .....	168
3.2.4.Hypotheses .....	172
3.2.5.Summary of the Conceptual Model .....	176
Bibliography .....	177
Appendices.....	199
Appendix 1: Probit Estimation Results by Country.....	199
Appendix2: Questionnaire Survey on Entrepreneurship Education for Engineering Students ..	199
Appendix 3: Inter-item Correlations .....	202

## List of Figures

Figure1 Entrepreneurial Employment Levels among Ten Sub-Saharan African Countries.....	4
Figure 2 Firm Entry Density by Region, 2004-2012 .....	4
Figure 3 Entrepreneurship rate, by Country .....	9
Figure 4 Entrepreneurship rate across Age.....	11
Figure 5 Entrepreneurship Rate by Gender .....	13
Figure 6 Entrepreneurship Rate, by Gender and Country.....	14
Figure 7 Characteristics of Opportunity and Necessity Entrepreneurs.....	15
Figure 8 Entrepreneurship Knowledge, Skills & Fear of Failure by Gender .....	17
Figure 9 Relative Entrepreneur and Non-entrepreneurs characteristics .....	18
Figure 10 Percent of Firms Expected to Give Gifts to Public Officials to Get Things Done.....	28
Figure 11 Control of Corruption.....	29
Figure 12 Total Tax Rates by Region.....	30
Figure 13 Credit-Constrained Firms by Size and Region.....	37
Figure 14 Data Analysis Procedure .....	58
Figure15 SEM path model for the constructs of the Theory of Planned Behavior.....	86
Figure 16 Difference-in-Difference Approach .....	93
Figure17 Aspects of Entrepreneurship .....	105
Figure 18 Phases of Entrepreneurial Process.....	107
Figure19 The Entrepreneurial Thinking, Based on NewSchools Venture Fund .....	107
Figure 20 Objectives of Entrepreneurship Education.....	138
Figure 21 Summary of Entrepreneurship Education Impact Studies.....	142
Figure 22 Sectors the 21st Century top Entrepreneurs engaged in.....	145
Figure 23 Trait Personality Model.....	149
Figure 24 Entrepreneurial Event Model (EEM) .....	153
Figure 25 Entrepreneurial Intention model (EIM).....	156
Figure 26 Revised entrepreneurial intention model (Revised EIM).....	157
Figure 27 Ajzen's Theory of planned behavior (TPB) .....	160
Figure 28 Education-Entrepreneurship Intention Model .....	176

## List of Tables

Table 1 Entrepreneurial Rates across age and country .....	10
Table 2 Entrepreneurship and Individual Characteristics.....	12
Table 3 Mean differences in the fear of failure between man and woman .....	19
Table 4 Probit Regression Results (Marginal Effects) .....	21
Table 5 Predicted Probabilities .....	23
Table 6 Doing Business Indicators .....	32
Table 7 Infrastructure Challenges to Entrepreneurship .....	35
Table 8 Access to Finance .....	36
Table 9 Tests for Selection Bias .....	59
Table 10 Tests for Normal Distribution.....	60
Table 11 Test for Multicollinearity.....	60
Table 12 Demographic Differences between the Entrepreneurship and Control Group .....	61
Table 13 Tests for Reliability .....	64
Table 14 Factor Loadings of the Theory of Planned Behavior.....	66

Table 15 Characteristics of Respondents.....	71
Table 16 Percentages of Students for the Constructs of Theory of Planned Behavior.....	74
Table 17 Constructs of Theory of Planned Behavior before and after the Course.....	75
Table 18 Logarithmic Changes in the Constructs of Theory of Planned Behavior.....	75
Table 19 Analysis of the Students Entrepreneurial Perception.....	75
Table 20 Analysis of Variance for Perception to Entrepreneurship Test Score (Control Group, 120)	76
Table 21 Analysis of Variance for Perception to Entrepreneurship Test Score (Entrepreneurship Group, 150).....	76
Table 22 Effect of Age, Fathers' Level of Education, Mothers' Level of Education, and Income.....	78
Table 23 Effect of Gender (Comparing females/males between Entrepreneurship and Control group).....	78
Table 24 Effect of Gender (Comparing females/males within Entrepreneurship or Control Group)...	78
Table 25 Effect of Fself (Comparing No/Yes between Entrepreneurship and Control group).....	80
Table 26 Effect of Fself (Comparing No/Yes within Entrepreneurship or Control group).....	80
Table 27 Effect of Mself (Comparing No/Yes between Entrepreneurship and Control group).....	80
Table 28 Effect of Mself (Comparing No/Yes within Entrepreneurship or Control group).....	80
Table 29 Effect of Staexp (Comparing No/Yes between Entrepreneurship and Control group).....	81
Table 30 Effect of Staexp (Comparing No/Yes within Entrepreneurship or Control group).....	82
Table 31 Effect of Stevl (Comparing Negative/Positive between Entrepreneurship and Control group).....	82
Table 32 Effect of Steval (Comparing females/males within Entrepreneurship or Control group).....	82
Table 33 Effect of SelfEm (Comparing No/Yes between Entrepreneurship and Control group).....	82
Table 34 Effect of SelfEm (Comparing No/Yes within Entrepreneurship or Control group).....	83
Table 35 SEM Results.....	87
Table 36 Results of Sobel test.....	91
Table 37 Difference-in-Difference Analysis of the Effect of Entrepreneurial Education.....	95
Table 38 Summary of the Different Definitions of Entrepreneurship and Entrepreneur.....	108
Table 39 Rate of Gender Participation in Entrepreneurship.....	114
Table 40 Summary of Entrepreneurship Education Impact Studies.....	140
Table 41 Application of Entrepreneurial Event Model.....	154
Table 42 Summary of Pervious Studies on Using Theory of Planned Behavior.....	161



## Abstract

Entrepreneurship has become one of the veritable agents of change to tackle unemployment, drive innovation, fuel economic growth, and grease the skids' of development. At the same time, empirical studies unfolded that the ability of entrepreneurs to thrive in today's dynamic economic system is counting on a number of varied multidimensional challenges be it individual, economic, technological, and / or institutional variables. As such entrepreneurial act has long been eclectic across individuals (male vs Female, educated vs uneducated, young vs old, poor vs rich etc.) and nations (simple and flexible regulations vs cumbersome regulations).

Accordingly, policy makers are all but in agreement to draw assortment of measures that can engender and smoothen the functioning of entrepreneurship. Entrepreneurship education has recently been proliferating as one of the key pro-entrepreneurship policy devices all around though its impact is thus far unclear empirically. This study therefore sets out to put light on its effect to enhance entrepreneurial intention using the theory of planned behavior as the underlying theoretical model. We estimated the conceptual model using structural equation modeling and difference-in-difference analysis in a pre-post design with a sample of 270 engineering students (150 experimental and 120 control group) at Debre Berhan University. The results showed a significant positive impact of entrepreneurship education on entrepreneurial intention of the students. The impact of the course however varied with the initial entrepreneurial intention before the course. For students who started with low values in the constructs of the theory of planned behavior, the impact of the course was significantly positive and much greater than those having the highest level of initial entrepreneurial intention. Its impact on the latter one was quite meager. The results also evidenced that the relationships among the three antecedents of the theory of planned behavior were not indistinct. There was a significant dependent relationship among them. The study thus is of prodigious theoretical and practical contributions in advancing entrepreneurship education as a distinct academic field, and entrepreneurship as a dependable career option. In regards, it has a theoretical contribution of playing up the application of the theory of planned behavior to appraise entrepreneurship education, and a practical contribution of giving a profound insight on how to prepare and deliver effective entrepreneurship education programs/or trainings /or courses.

## I. Introduction

The notion of engendering greater entrepreneurial act by policy makers and scholars cannot in anyway be overstated. Entrepreneurial innovation has incontestably become the mainspring for a buoyant economic and social development of several countries. As such, it is one of the veritable agents of change to tackle unemployment, drive innovation, shake up a lethargic economic growth, and grease the skids' of development.

The last two decades have witnessed a wealth of studies providing empirical evidence that sheds light on the basic concepts underlying the arguments. Reynolds et al. (1999) found that one-third of the differences in national economic growth rates could be attributed to differences in entrepreneurial activity. Similarly, Zacharakis et al. (2000) parsed the relationship between entrepreneurship and growth on sixteen developed economies and found that entrepreneurial activity explained approximately one-half of the differences in GDP growth among countries. Notwithstanding the insignificant relationship they found, Reynolds et al. (2004) also noted that countries with high levels of entrepreneurial activity have above average levels of economic growth. They further demonstrated that no country with entrepreneurial activity levels has low economic growth. Similarly, small businesses which are often created by self-employed entrepreneurs provide approximately 75% of the net jobs added to the American Economy each year and represent over 99% of all U.S employers (Rugy, 2005).

The importance of entrepreneurship as a catalyst to economic growth and a means of combating unemployment has also been evident in Africa. Surrogating entrepreneurship with Small and medium sized enterprises, Okafor (2006) found that 50% of employment and GDP in Africa was attributed to entrepreneurship. Recently, Abor and Quartey (2010) found that entrepreneurship had contributed to 52% to 57% of GDP and around 61% of employment in South Africa, and 85% of manufacturing employment and 70% of GDP in Ghana. They also provided employment opportunities for 50% of Nigerian population (Ariyo, 2005).

It is apparent that entrepreneurship, in light of the above, looks like a fairly viable and uncontested solution for the ever growing and educated youth population that is becoming a pressing issue in Africa. Needless to say, Africa is becoming the most youthful population in the world. The Youth and African Union Commission has predicted that by 2020 nearly three in four people living in the continent would be, on average 20 years old, and each year around 10 million youth join the labor market. At the same time, there has also been a profound increment in the number of

university graduates. It increased almost by 150% between 1999 and 2009; increased from 1.6 million to 4.9 million and due to reach 9.6 million in 2020 (African Economic Outlook, 2012).

By contrast, we argue that the very nature of the job market is complex and tough for the youth to access. The labor market has notably become more hostile for the young people in Africa. They are much more hurt compared to adults. On this regard, the International labor Organization (ILO) claimed that of the 73 million jobs created in Africa, only 16 million jobs were for young people aged between 15 and 24. They account for 60% of all African unemployed (African Economic Outlook, 2012).

The costs of a long-term disengagement of youth from the labor market are ostensibly impossible to overlook. The problem of youth unemployment is pernicious for the whole of an economy. The series of anti-government protests, uprisings and armed rebellions that spread across the Middle East and North Africa in recent years plainly witness instances that the youth unemployment has caused.

In fact, it looks apparent that policy makers in Africa are all but in agreement to enabling the population to have a go at start-ups essential to tackle the pressing (youth) unemployment dilemma.

Most of them have put in place specific entrepreneurship initiatives incorporated in their long term strategic plans. Ethiopia's Growth and Transformation plan 2010/11-2014/15, Zambia's 6<sup>th</sup> National Development Plan 2011-2015, South Africa's Broad-Based Black Economic Empowerment Act of 2003 and the Youth Entrepreneurship Strategy and Policy Framework 2009 all embrace entrepreneurship as a key tool of innovation, job creation, poverty reduction and development. In this connection, there has now been a surge in the number of different offices and agencies to coordinate and manage entrepreneurial initiatives and policies. For instance, Mauritius has mainstreamed entrepreneurship in the activities of the Ministry of Gender Equality, Child Development and Family Welfare, and Botswana has delegated the ministry of trade and industry to coordinate entrepreneurship policy (UNCTAD, 2012a). Similarly, the Ethiopian government established the Federal Micro and Small Enterprises Development Agency in 1998 (Federal Negarit Gazeta, 1998).

It is also evident that many African countries are not short of business regulatory reforms that are intended to invigorating entrepreneurial activity.

According to the World Bank Doing Business (2015), 74% of Sub-Saharan Africa countries have improved business regulatory environment for local entrepreneurs. This accounted for about 30% of the regulatory reforms making it easier to do business in 2014/15 (Doing Business, 2016).

But we question, however, whether the impressive figures presented above really represent an actual entrepreneurial success in the region. For that we assessed the state of the different proxies for entrepreneurial success such as job creation rate, entry density and failure rate. The results unfolded a different story. They were to no avail.

We considered the following three argumentations to justify the perplexing relationship between entrepreneurial success and policy measures undertaken in Africa.

First, the job creation rate of entrepreneurs in (Sub-Saharan) Africa is far below the rates in other regions. A recent study on the relationship between entrepreneurship and income per capita in developing countries showed that each firm joining the formal sector in Africa generated 24.4 permanent jobs on average, which was less than half of the jobs created by firms in other regions (UNCTAD, 2012b). The Global Entrepreneurship Monitor's (GEM) survey data on the job creation rate of entrepreneurship in Sub-Saharan Africa reinforces the study result. According to the survey, it was only 2 percent of the enterprises that created 20 and more jobs (figure1). More than 83 percent of the entrepreneurs however created jobs only for five and less than five individuals. The job creation rate was distinctively low in Ghana, Uganda and Malawi; 82 percent of entrepreneurs in Malawi, and 59 percent of entrepreneurs in Ghana and Uganda run only one person businesses. The job creation prospects or expectations for growth of these enterprises were also not a different (GEM, 2012).

Second, the entrepreneurship resource in Sub-Saharan Africa is still very scarce. The per capita firm entry or business entry density is quite scanty (Doing Business, 2016).

Compared to other regions, firm growth in the region is rather stunting. Sub-Saharan Africa registered the second lowest entry density, topped only South Asia. Entry density in Sub-Saharan Africa was around 2 % against 7.35% in Europe and Central Asia, and 6.44 % in East Asia and Pacific. That is, there were only around two limited liability firms registered annually per 1000 people in Sub-Saharan Africa compared to 7 limited liability firms in Europe and Central Asia and 6 limited liability firms in East Asia and Pacific. It on the other hand means that on average, the number of limited liability firms created in Sub-Saharan Africa was almost one third of the average number in Europe and Central Asia, and East Asia and Pacific.

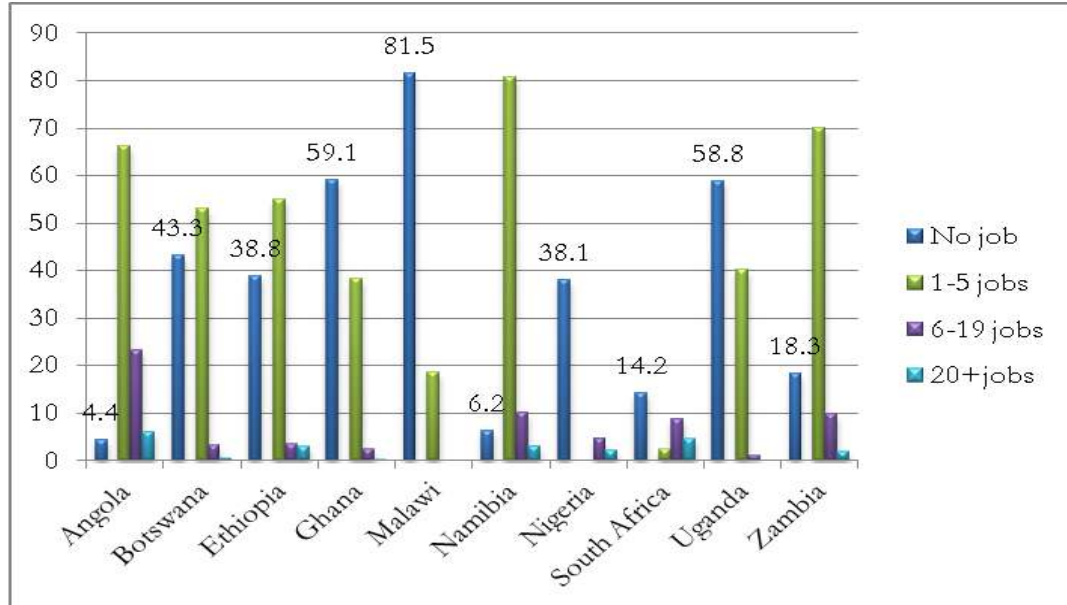

Figure1 Entrepreneurial Employment Levels among Ten Sub-Saharan African Countries  
Source: Compiled Based on GEM (2012)

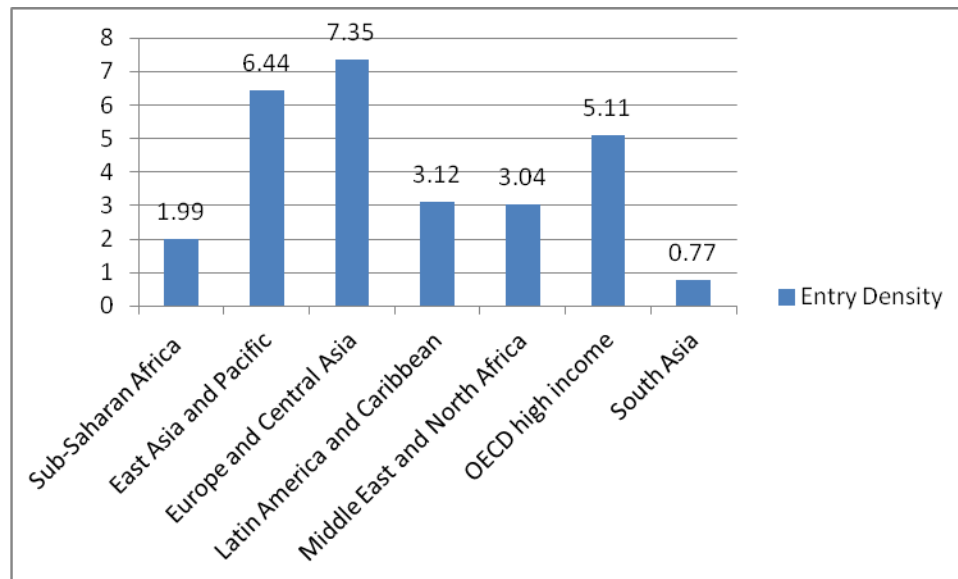

Figure 2 Firm Entry Density by Region, 2004-2012  
Source: Own Computation Based on World Bank Doing Business Database

Third, it also looks apparent that managing the growth and development of new firms is lower than it has to be to brim Africa with successful entrepreneurs. A comparative analysis of new firms' performance in Sub-Saharan Africa once again showed that the number of firms that relinquished

their business was much higher than other regions. A great portion of nascent entrepreneurs usually face difficulty seeing their vision through to a viable and promising one. According to Babson news on the status of Entrepreneurship in Africa, it was claimed that over 16% of adults in Sub-Saharan Africa discontinued a business in 2011, reaching as high as 29% in Malawi, compared to Asia, Europe and the United States that showed only 3% to 4% of the population with business stops (GEM, 2012).

In view of the above, this dissertation sets out to achieve the following research objectives and gain profound insight into the working of entrepreneurship:

1. To investigate the entrepreneurship landscape in Africa. This primarily sets out to identify the individual characteristics of entrepreneurs which is an indispensable task to exactly put in place entrepreneurial policy priorities and directions pertaining to each group.
2. To highlight the prevailing entrepreneurial working environment with respect to the policy measures governments in (Sub-Saharan) Africa have taken. This gives a profound insight to identify, effectuate, reassess and determine the appropriate policy scale still required for a better entrepreneurial act. In doing so, we employed a comparative and international perspective which was somewhat voided from previous studies. Employing a comparative and international perspective gives governments and policy makers an important discernment to identify, effectuate, reassess and determine the appropriate policy scale and bring about a conducive entrepreneurial working environment for business to grow and flourish.
3. To evaluate the effectiveness of pro-entrepreneurship policies undertaken to thriving an entrepreneurial act. As such we focus on investigating the role of entrepreneurship education on intention to entrepreneurship.

Accordingly, the dissertation sets out to redress the research objectives in three separate chapters. The first chapter intends to explore the characteristics of entrepreneurs in Africa. Chapter two aims to examine the working environment or business climate for entrepreneurial act. The third chapter examines the relationship between entrepreneurship education and intention to entrepreneurship in a more rigorous way which was hardly available in previous studies.

## Chapter 1

# Individual Determinants of Entrepreneurship in Africa: Analysis Based on GEM Data

1. Introduction 2. Descriptive statistics 3. Hypotheses Testing 4. Concluding Remarks

## 1. Introduction

Entrepreneurship literature shows that entrepreneurs come from people with different background characteristics. People exploit entrepreneurial opportunities differently. As a result, identifying the individual characteristics that spur entrepreneurial act more pronouncedly has been the subject of much empirical investigation. Our investigation of the characteristics of entrepreneurs in this section also followed the same procedure. It aims to give a deep insight on the characteristics of entrepreneurs in Africa in a comparative perspective that was dearth in previous studies. The results posit that entrepreneurship is not such an easy that everyone who wishes to own a firm manages to make a go of it. At the same time, being entrepreneurial isn't the exclusive preserve of a specific group of people. There is no single recipe at all to be an entrepreneur. But generally it turns out that entrepreneurial act has potentially a positive and statistically robust link with people who possess the skills, knowledge and information pertaining to entrepreneurship. Similarly, people with work experience, from low income and low education group are invariably tended to own a business. *Ceteris paribus*, it is also evinced that the odds of a man tended to start a business are higher than that of a woman. In fact, alike the young, low income and low education people, a woman is more likely to engage in necessity based entrepreneurship than a man.

The remaining part of this chapter provides a detail analysis of the relationship between entrepreneurship and individual characteristics.

To illustrate the characteristics of individuals who engage in early stage entrepreneurial activities in Africa, we used a survey data collected by the Global Entrepreneurship Monitor (GEM). It is an ongoing academic project started in 1997 to collect and assess entrepreneurial activity, aspirations and attitudes of people across a wide array of countries in a yearly basis. Needless to say, it is one of the comprehensive efforts to study entrepreneurship.

The dataset contains the whole working age group (18-64 years age) in each participating country for both entrepreneurs and non-entrepreneurs. It has thus a great advantage of inclusiveness.

We used the GEM 2009 Adult Population Survey Data, the most recent survey available for the countries in the study to researchers who are not directly involved in the project. The study spanned five African countries such as Algeria, Morocco, Tunisia, Uganda and South Africa based on data availability on the variables of interest. The total number of observations in the sample is 10058. The variable we used to represent potential entrepreneurial activity is the total entrepreneurial activity (*teayy*). It includes total opportunity entrepreneurial activity (*teayyopp*) and total remedial (necessity) entrepreneurial activity (*teayynec*) based on the motives of the entrepreneur to start a firm.

The *teayy* rate is the proportion of people aged 18-64 who are involved in entrepreneurial activity as a nascent entrepreneur or as an owner-manager of a new business (GEM, 2009). It is an indicator variable equal to one if individuals are starting a new business or are owners and managers of a young firm; it is equal to zero otherwise.

*teayyopp* is an indicator variable equal to one if individuals are pursuing a new business or are owners and managers of a young firm (by choice), to take advantage of a business opportunity; it is equal to zero otherwise (opportunity or for profit entrepreneurs hereafter).

*teayynec* is an indicator variable equal to one if individuals are starting a new business or are owners and managers of a young firm because they could find no better economic work or wage employment to eke out a living; it is equal to zero otherwise (remedial or necessity entrepreneurs hereafter).

In this sense each respondent was asked to indicate whether he/she was starting and growing his/her business to take advantage of a unique market opportunity (opportunity entrepreneurship) or because it was the best option available (necessity entrepreneurship) as indicated by (Reynolds et al., 2002).

In effect individuals starting a new firm include the percentage of 18-64 years old population who are either a nascent entrepreneur or owner-manager of a new business.

Reynolds et al (2004) defined “nascent entrepreneur” as a person who is now trying to start a new business, who expects to be the owner or part owner of the new firm, who has been active in trying to start the new firm in the past 12 months and whose start-up did not have a positive monthly cash flow that covers expenses and the owner- manager salaries for more than three months. On the other hand, based on Ardagna and Lusardi (2008) individuals who are “owners and managers ” of a young firm are individuals who, alone or with others, are the owners of a company they help



manage, provided that the company has been paying salaries and wages for no more than 42 months.

In regards, the focus is on firms at the initial planning or inception stage (GEM, 2009). That is, the data represents the potential supply of entrepreneurs rather than the actual rate of entrepreneurship. In fact, using data at this stage of firm creation is of utmost importance to identify the reasons why many fledgling firms fail and end up in smoke. Assessing the individual characteristics of early stage entrepreneurs, therefore, allows to take a plausible policy mix from the grass root and consequentially contribute for a considerable innovation, job creation, productivity and ultimately overall growth.

## 2. Descriptive Statistics

In this section we discuss the individual characteristics of entrepreneurs using various descriptive measures like averages, standard deviation, t-test, tables and graph.

Table1 shows the number of observations, the average *teayy*, *teayynec*, *teayyopp*, and the ratio of the variables *teayynec/teayyopp* for each country in the sample and for the group as a whole.

Examination of the table shows us that entrepreneurial activity has become a means of survival for 14.95% of the working age population. Out of this, around 51% of them are necessity entrepreneurs that start business due to lack of other employment opportunities while the remaining 49% are opportunity entrepreneurs who start business to capitalize on perceived opportunity.

Country wise analysis of table1 and figure3 apparently shows that in terms of total entrepreneurial activity, Uganda tops the highest position while South Africa ranked bottom with 32.3% and 5.7% respectively. Algeria follows Uganda with a total entrepreneurial activity of 16.48%.

Opportunity and necessity entrepreneurial activity rates also follow suit; the highest in Uganda and lowest in South Africa. Uganda attains 17.26% and 14.87% while South Africa scores 3.74% and 1.67% respectively in opportunity and necessity entrepreneurial rates.

In this connection, it is then crucial to stress on the impetus that people in the countries in the survey engage in entrepreneurial activity. The rate of entrepreneurship should have to be interpreted with an utmost care. For instance, though a tremendously high rate of entrepreneurship exists in Uganda, the greater portion of them are driven by non-existent or unsatisfactory employment options to get a foothold in the jobs market. The statistics plainly shows that the ratio

of necessity to opportunity (early stage) entrepreneurship in Uganda is far more than the other countries.

Ratio of necessity to opportunity entrepreneurship (teaynec/teayyopp) in Uganda is 86.15 followed by South Africa which is 44.65. In fact, the higher ratio of necessity to opportunity entrepreneurship particularly indicates that more people are basically not in to taking advantage of the growing business opportunity found in a specific country. They primarily join entrepreneurship for the lack of other career options to earn a living. In regards, in Uganda only 13.75% of early stage entrepreneurs are recognized as opportunity entrepreneurs compared to 86.15% necessity based entrepreneurs. On the other hand, in South Africa 44.65% of early stage entrepreneurs are necessity based compared to 54.35% of early stage entrepreneurs who are actually opportunity based.

This in fact clarifies some doubts cast on the reasons that entrepreneurship in some cases doesn't really thrive growth of an economy. Entrepreneurship evidently causes growth and improves quality of life however if and only if it is of a productive or opportunity based nature. As a matter of fact, necessity based entrepreneurs are not likely to create value since these start-ups are oftentimes low skill and small subsistence activities.

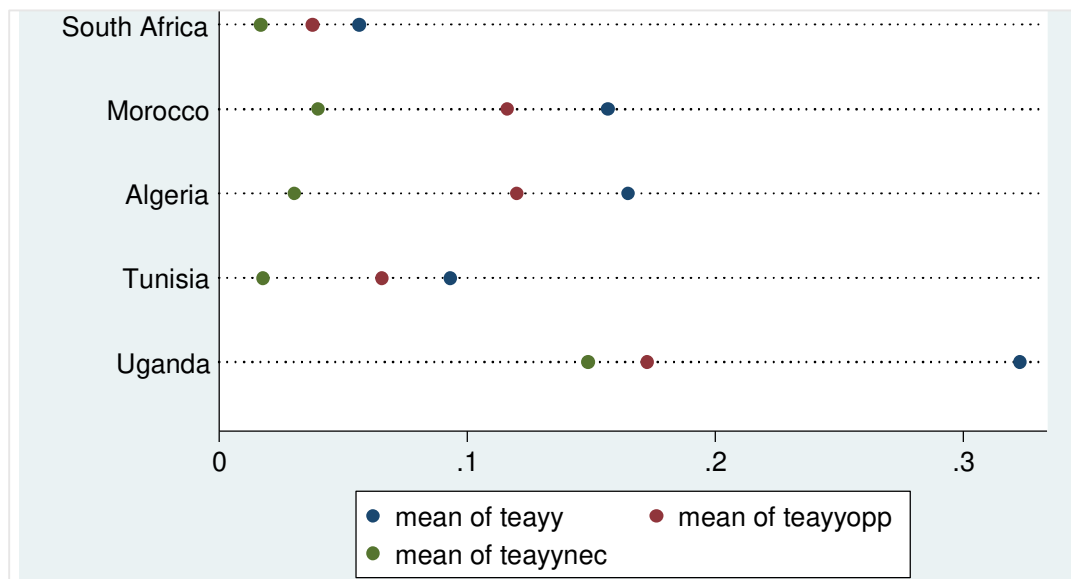

Figure 3 Entrepreneurship rate, by Country  
 Source: Own Computation based on GEM 2009 database

Table 1 Entrepreneurial Rates across age and country

Age	South Africa=2939			Morocco=1405			Algeria=1875			Tunisia=1875			Uganda=1964			Total =100 58
	teayy	tea yyo pp	teayy nec	tea yy	tea yyo pp	teayy nec	tea yy	tea yyo pp	teayy nec	tea yy	tea yyo pp	teayy nec	tea yy	tea yyo pp	teayy nec	Indivi duals
18-24	4.8	3.2	1.5	14	10	3.6	17	11	4.2	8.6	5.6	2.3	36	20	15.7	15.62
25-34	7.4	4.7	2.4	20	15	4.9	18	15	2.5	11	7.5	1.9	33	19	14.3	17.62
35-44	8.2	5.3	2.3	16	11	4.3	19	14	3.1	7.9	5.7	1.7	33	16	16.6	16.11
45-54	5.1	3.9	1.2	13	10	3.1	16	12	2.8	11	8.0	1.7	29	15.	13.6	13.64
55-64	2.6	2.2	0.4	12	9.3	3.1	5.3	2.9	1.2	7	6	0	19	7.3	11.7	7.95
65-	1.6	1.6	0	0	0	0	0	0	0	0	0	0	0	0	0	1.65
Total	5.7	3.7	1.7	16	12	4	17	12	3.0	9.3	6.6	1.8	32	17	14.9	14.95
teayyn ec/tea yyopp	44.65			34.40			25.33			26.83			86.15			50.73

Source: Own computation based on GEM2009 database

To operationalize and characterize the entrepreneurship landscape in Africa, as considerably indicated in the literature survey, we included age, gender, education, working status and income as the main individual variables describing entrepreneurial activity. We also controlled for self-assessed business skills, fear of failure and social network in the analysis.

Self-assessed business skills (*Suskilyy*) is a dummy variable equal to one if an individual believes/answers that he or she has the knowledge, skill, and experience to start a new business; the variable is equal to zero otherwise.

Fear of failure, a proxy for individual attitudes toward risk, is measured by the dummy variable *Fearfail*, represents individuals with positive perceived opportunities who indicate that fear of failure dissuades them from setting up a new business. In this sense it is equal to one for individuals who indicate that fear of failure prevents them from starting a new business; the variable is equal to zero otherwise.

Social network is measured with the dummy variable *Knownenyy*, which is equal to one if an individual personally knows some people that has started a business in the past two years; the variable is equal to zero otherwise.

Finally, individuals are put in to three income records. They are grouped as the lowest 33% tile (*hhinc1*), middle 33% tile (*hhinc2*) or upper 33% tile (*hhinc3*).<sup>1</sup> In this sense, *hhinc1* becomes one if the individual is in the lowest income group, equal to zero otherwise. The same applies to *hhinc2* and *hhinc3*.

A detailed analysis of the descriptive statistics evidences that entrepreneurial act in Africa is characterized by a consequentially significant and non-linear age difference. The highest rate of entrepreneurs lies in the age range 25-44 years, followed by the youth cohort. The participation rate for the age range 25-44 years was 16.87% while it was less only by 1.25% percentage for the age cohort 18-24 years. Rate of participation for older groups decreases accordingly. It was 13.6% for the age group 45-54 years, 7.9% for 55-64 years and 1.6% for 65 and over years.

Thus the age profile of individuals declared as entrepreneurs then appears to be close to inverted “u-shaped” skewed more to the right (figure 4).

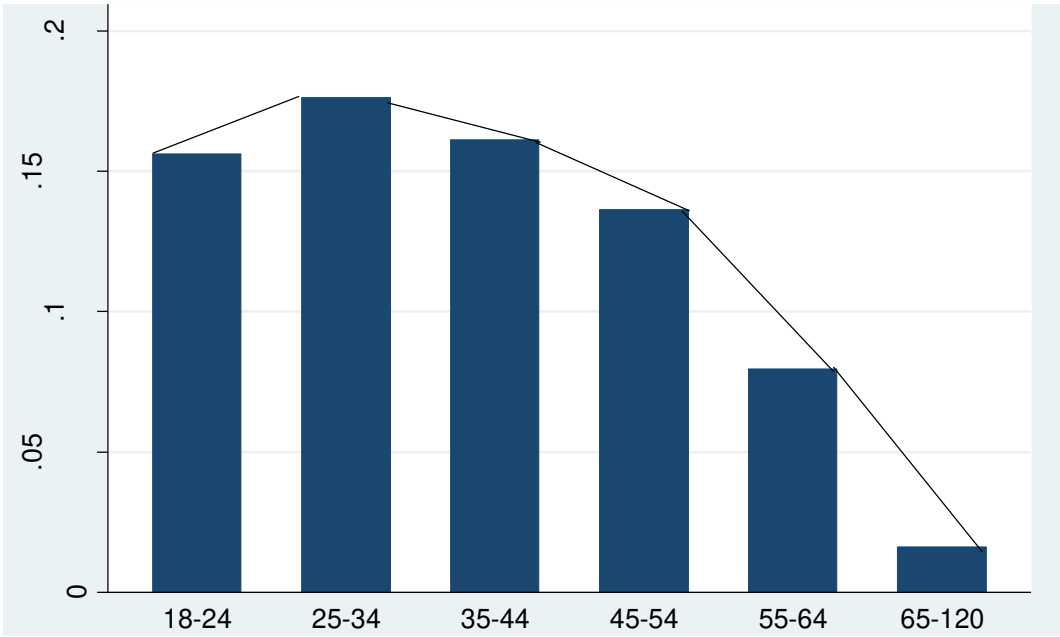

Figure 4 Entrepreneurship rate across Age  
 Source: Own Computation based on GEM 2009 database

The descriptive results also clearly show an underlying age difference between opportunity and necessity entrepreneurs. We found that necessity entrepreneurs are markedly younger than

<sup>1</sup> Categories are in fact not 33% but rather based on categories provided by each country or income brackets in national household income distribution of the respective countries.

opportunity entrepreneurs. The average age of necessity entrepreneurs is 32.3 years against 33.1 years for opportunity entrepreneurs and indeed the difference is statistically significant at 1% significance level.

This may be attributed to the experience people have in the labor market. The lack of job related stocks of knowledge and skills makes the job market such a difficult place to access for young people. Accordingly, they are relatively propelled to form necessity-based entrepreneurship to earn a living. This on the other hand then implies that the one with a better work experience is poster child for opportunity entrepreneurship.

Table 2 Entrepreneurship and Individual Characteristics

Variables	teayy= 1	teayy= 0	St. error of diff	teayyopp =1	teayynec= 1	St. error of diff
<i>Age</i>	32.88	35.68	.38*	33.11	32.3	.46*
<i>%male</i>	56.12	46.74	.014*	60	47.2	.017*
<i>% Working</i>	80.6	43.9	.014*	81.7	79.6	.017*
<i>% Not working</i>	13.5	38.4	.013*	11.96	15.6	.016*
<i>%Retired and students</i>	5.97	17.69	.01*	6.35	4.78	.012*
<i>%No Education</i>	36.74	28.88	.013*	29.50	52.98	.016*
<i>%Secondary</i>	48.96	54.90	.014*	53.21	41.03	.017
<i>%University</i>	14.30	16.23	.010	17.28	5.98	.012
<i>%low income</i>	53.09	31.28	.016*	50.09	60.42	.02*
<i>% Middle Income</i>	11.83	22.26	.014*	14.73	6.25	.018*
<i>%Upper Income</i>	35.08	46.46	.018*	35.18	33.33	.02*
<i>% Knowent</i>	71.6	45.9	.02*	73.77	66.8	.03*
<i>% Suskill</i>	85.35	52.8	.02*	84.9	87.6	.025*
<i>% Fearfail</i>	25.67	27.24	.019	24.75	26.79	.023

\*= Difference in mean statistically different from zero at 1%

Along with the substantial age difference, the statistics also evinced a significant gender bias a cross entrepreneurs in Africa. Consistent with previous research (*Literature Review, Chapter1*), women

are less likely than men to start a firm. On average, 17.43% of the men in the sample have been participating in early stage entrepreneurial activities against 12.65% of the women.

An equally significant aspect of this gender bias is also observed on the nature of entrepreneurial act people are engaged in per se. The proportion of men engaged in opportunity entrepreneurship is rather higher than the ones engaged in necessity entrepreneurship. They represent 60% of opportunity and 47% of necessity entrepreneurs. Conversely, the proportion of women engaged in necessity entrepreneurship is significantly higher than the proportion of women engaged in opportunity entrepreneurship. Women take 53% of necessity and 40% of opportunity entrepreneurs. Hence, the percentage of men who participate in opportunity entrepreneurial activity is 20% more than the percentage of women who participate in opportunity entrepreneurship. By contrast, the percentage of women who engage in necessity entrepreneurship activity is only 6% more than the percentage of men who participate in necessity entrepreneurship. This evidently shows that necessity entrepreneurs are less gender sensitive than opportunity entrepreneurs (figure5).

The gender gap in entrepreneurship could be explained by, consistent with literature review, chapter one, the fact that women face critical barriers to entry in the formal market and must resort to entrepreneurship as a way out of unemployment (and often out of poverty). Women are more family oriented, less risk-takers, feel less capable and are less keen to setting up a business and perusing expansion related goals.

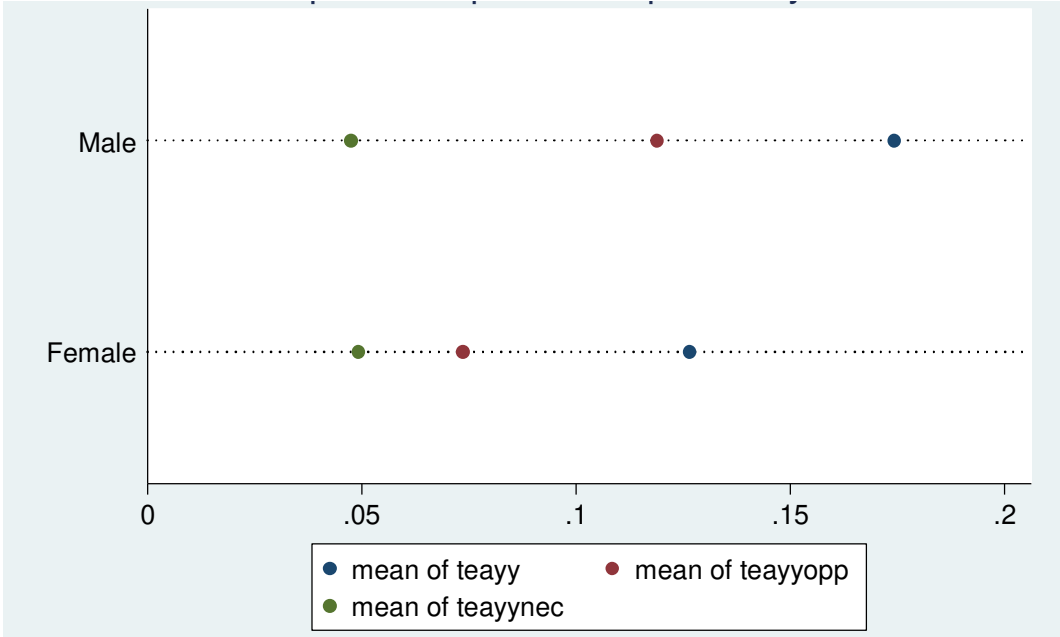

Figure 5 Entrepreneurship Rate by Gender  
Own Computation based on GEM 2009 database

The gender gap is the highest in Tunisia followed by Morocco; men are 9.46% and 7.54% respectively more likely to get in to business than women. The minimum gender gap is found in South Africa where women are 2.42% less favorites to embark on startups than men. At this point we can learn that the gender gap is arguably a reflection of the culture and the level of development of a country. In countries such as Morocco and Tunisia where man is considered as the sole breadwinner and head of the household, women entrepreneurship is somewhat stunted and the gender gap soars. On the other hand, in countries like South Africa where the level of development is relatively higher, the gender gap is clearly lower than in less developed countries. The rate of women entrepreneurs is close to the rate of men entrepreneurs. Figure6 also tells us a very interesting story. In developed countries like South Africa the entrepreneurship rate is somewhat lower than in developing countries. This actually strengthens the premises we put at the beginning about instrumentality of entrepreneurship as an alternative career option. Compared to developed countries, the job market in developing countries has a narrow base in such a way that people can easily, if not by choice, be pushed to entrepreneurship as a last resort to earn a living.

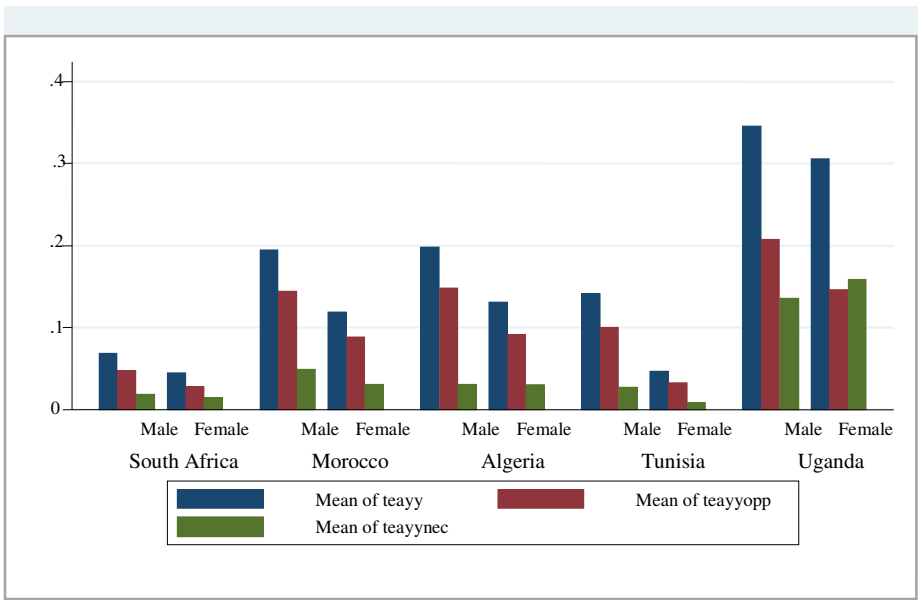

Figure 6 Entrepreneurship Rate, by Gender and Country  
 Source: Own Computation Based on GEM 2009 database

For the very fact we mentioned in the literature review Chapter one, people with no education experience face difficulty joining the competitive job market. As a result, they are rather pushed to

work on necessity-based entrepreneurship. This is in fact what our descriptive statistics clearly witnessed. Very strikingly, increment in the level of education however doesn't really bring about any meaningful difference in engagement in the two types of entrepreneurship such as both necessity and opportunity entrepreneurship.

Though it needs further consideration, the result evidently confirms that the education system in the institutions of these countries does not target producing more entrepreneurs. Rather, it seems that the institutions envision their graduates to be employed in various sectors of an economy. They don't apparently educate the relevant knowledge and skills needed to realize and exploit entrepreneurial opportunities.

In fact it may also be true that people who have higher levels of education face no difficulty getting a better employment opportunity with higher salary and without any risk that they would rather bear should they join entrepreneurship.

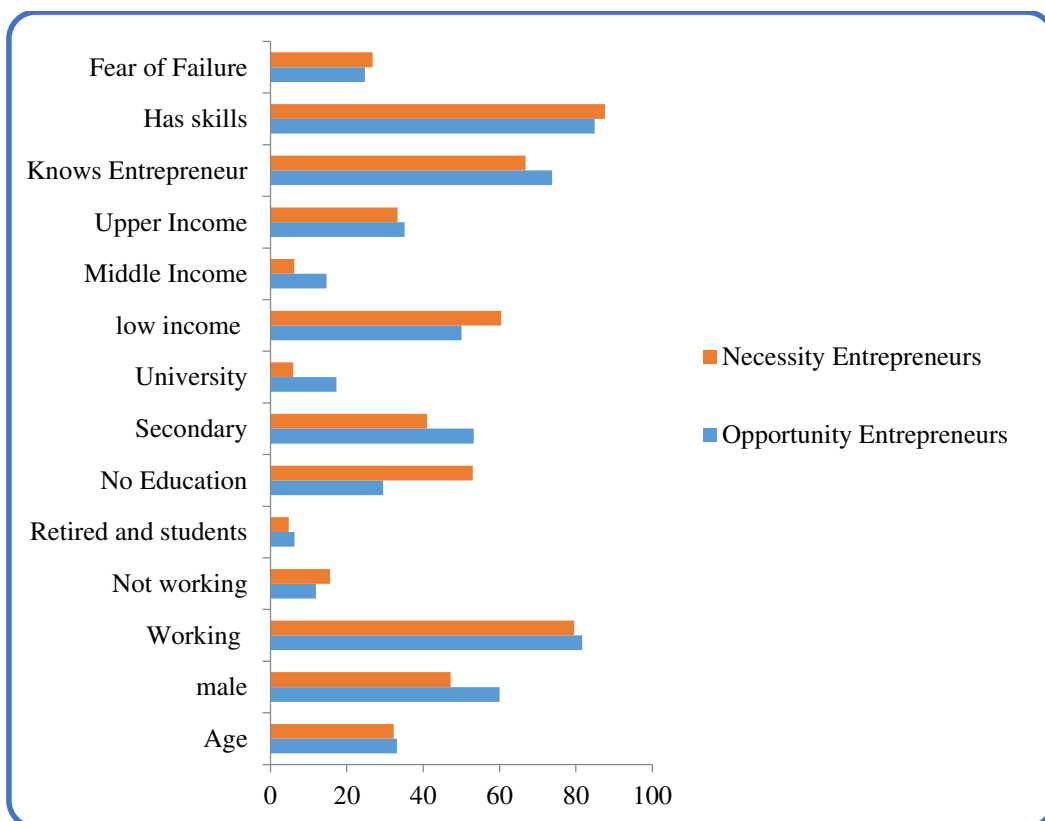

Figure 7 Characteristics of Opportunity and Necessity Entrepreneurs  
 Source: Own Computation based on GEM2009 database

Concerning household income, as expected, low income individuals are biased clearly towards necessity entrepreneurial activities while the other income groups participated more in opportunity



entrepreneurship than in necessity entrepreneurs. However, there appears to be a non-linear relationship between income and early stage entrepreneurial activity. The upper income groups trailed the lowest income groups in the percentage of people engaged in entrepreneurial act. On the face of it, 53.1% of entrepreneurs are from the lowest income group while 35.08% are from the upper income group against only 11.83% from the middle income group. This, in fact, might be related with the fact that middle income individuals are usually wage employees and they tend to prefer to a steady and more stable salary than engaging in a more risky entrepreneurial activities. Of central to this study is also the relationship between the characteristics of entrepreneurs and non-entrepreneurs. The summary measures (table2) indicated basic differences between entrepreneurs and non-entrepreneurs.

There is a substantial age difference between entrepreneurs and non-entrepreneurs. Entrepreneurs are found to be younger than the non-entrepreneurs. On average, the age of entrepreneurs is lower by 3 or so years than the age of non-entrepreneurs and is statistically significant at 1% level of significance: 32.3years versus 35.70years. This can be explained by the mere fact that young people generally lacks the skills and experience that the job market demands so that they are thrust to entrepreneurship.

It is also important to note that entrepreneurs are more likely to include more male than the non-entrepreneurs do so. Male constitute 56.12% of entrepreneurs and 46.74% of non-entrepreneurs. In other words, women represent the greater share of non-entrepreneurs; 53.26% of non-entrepreneurs against 43.88% of entrepreneurs.

One very important consideration at this point is that the difference abilities of men and women in starting business can be explained by their difference in fear perceptions, in their business knowledge, or social networks. Our results show that men are more likely than women to know someone who started a business (61% men compared to 47% women).

In addition, women are more afraid of failure than men. 25% of men say that fear of failure (fearfail) would prevent them from starting a business compared to 29% of women. Once more, men have a better self-assessed business skills than women (69% men compared to 60%). This pattern is profoundly significant in all 5 countries.

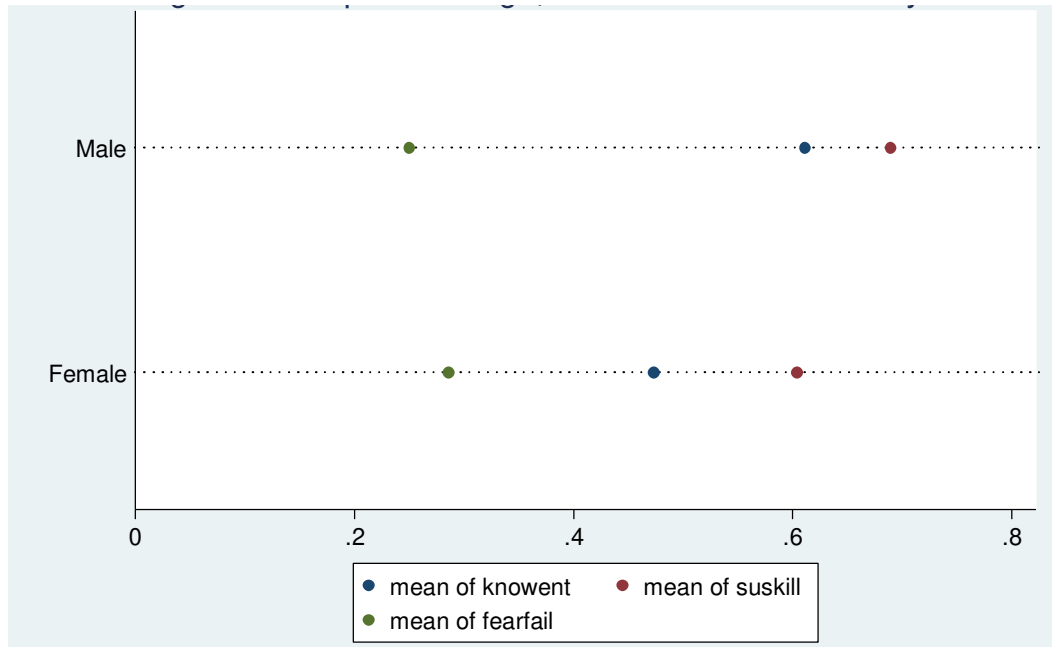

Figure 8 Entrepreneurship Knowledge, Skills & Fear of Failure by Gender

Source: Own Computation based on GEM 2009 database

There is also a telling difference between entrepreneurs and non-entrepreneurs in their work experience. Entrepreneurs have much better work experience than non-entrepreneurs: 80.6% of entrepreneurs have been working compared to only 43.9% of non-entrepreneurs have been working. It is true that work experience is a big addition to develop the knowledge, skills and connections needed to form a venture and can help to reduce the uncertainty about the challenges and prospects in the workings of entrepreneurship. In fact, our results also show that the greater share of non-entrepreneurs comprise of students, retired individuals and those who didn't have work experience during the survey.

The difference between entrepreneurs and non-entrepreneurs across the level of education is however dubious. People with no (less) education experience makeup the larger part of entrepreneurs than they do non-entrepreneurs. 36.74% of the entrepreneurs don't have education experience against 28.88% of the non-entrepreneurs with a significance difference at 1% level. The story changes however for people who have had education experience. For instance, the percentage of non-entrepreneurs is more than the percentage of entrepreneurs for people with secondary education experience: 54.90% against 48.96%. But the difference that university education experience creates between entrepreneurs and non-entrepreneurs is statistically insignificant; 14.3%

of entrepreneurs included people who had university experience against 16.23% who are non-entrepreneurs.

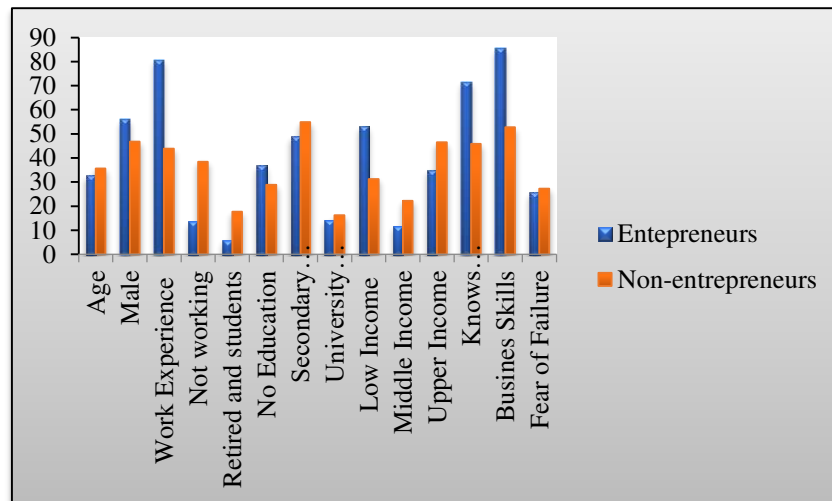

Figure 9 Relative Entrepreneur and Non-entrepreneurs characteristics

Source: Own Computation based on GEM2009 database

Income level of individuals was the other variable that showed visible difference between entrepreneurs and non-entrepreneurs. Consistent with literature, low income individuals are more apparently entrepreneurial than the other groups; 53.09% of entrepreneurs are from low income group while only 31.28% of non-entrepreneurs are from the same. More precisely, the percentage of low income individuals among entrepreneurs is 22% greater than the same among the non-entrepreneurs.

On the other hand, only 35.07% of the entrepreneurs were from high income groups compared to 46.46% of non-entrepreneurs are from high income groups and the difference between the two is insignificant at 1% level of significance. Respondents from middle income group makeup 11.83% of the entrepreneurs and 22.26% of non-entrepreneurs with a significant mean difference at 1% level of significance. In this sense, compared to entrepreneurs, the non-entrepreneurship group comprises a higher percentage of respondents from middle and high income respondents.

Quite interestingly there is no significant difference between entrepreneurs and non-entrepreneurs in their expectancy about failure. The percentage of respondents who said fear of failure wouldn't prevent them from starting a business also clearly revealed this; 73.14% of the respondents give optimistic response. Only 26.86% of the respondents in the survey believe that fear of failure is a

threat to starting business. But as explained in the *literature review, chapter one*, our results indicated that women fear failure than men; 28.58 per cent of women said that fear of failure would prevent them starting a business against 25% of men who said fear of failure would prevent them starting a business. The t-test result in fact shows a significant difference in the mean results between a man and a woman (at 1% level of significance).

Table 3 Mean differences in the fear of failure between man and woman

Two-sample t test with equal variances						
Group	Obs	Mean	Std. Err.	Std. Dev.	[95% Conf. Interval]	
Male	3099	.2500807	.0077805	.4331292	.2348252	.2653361
Female	3335	.2857571	.0078242	.451842	.2704164	.3010978
combined	6434	.2685732	.005526	.4432518	.2577404	.279406
diff		-.0356765	.0110513		-.0573407	-.0140122
diff = mean(Male) - mean(Female)					t =	-3.2282
Ho: diff = 0					degrees of freedom =	6432
Ha: diff < 0		Ha: diff != 0		Ha: diff > 0		
Pr(T < t) = 0.0006		Pr( T  >  t ) = 0.0013		Pr(T > t) = 0.9994		

Source: Own computation based on GEM 2009 database

Finally, the percentage of individuals who know someone who has started a business in the past two years and the percentage of individuals who think that they have the knowledge, skills, and experiences to start a new business are notably higher among entrepreneurs than among non-entrepreneurs. Around 72% of nascent entrepreneurs know someone who has business experience at some point compared to 46% of individuals who are not entrepreneurs know someone with business experience. In the same breath, close to 85% of nascent entrepreneurs realize that they have the required knowledge, skills and experience to start a business against around 53% of individuals who are not entrepreneurs think alike. The result can be explained by the fact that the more social ties a person has, the easier it will be getting information about entrepreneurial process and resources to exploit opportunities which then reduces the uncertainty that nascent entrepreneurs will face in their entrepreneurial career. The same is also true for those who think they have the knowledge, skills and experience about an entrepreneurial act.

### 3. Hypotheses Testing

In order to provide a framework for the empirical analysis that examines the nature of an individual that engages in total entrepreneurship activity, nascent entrepreneurship activity and /or opportunity entrepreneurship activity, we estimated a probit model paralleled with Wooldridge (2005) for the fact that the dependent variables– teayy, teaynec, teayyopp – are binary.

For individual  $i$ , in country  $j$ , with the outcome probability of participation in either of the entrepreneurial activities– teayy, teaynec, and teayyopp:

$$P(\text{Entrepreneur}_{ij}) = \alpha_j + \beta_1 X_{ij} + \varepsilon_{ij}$$

Where  $\alpha_j$  is a vector of country dummies,  $X$  is a vector of variables measuring individual characteristics such as age, gender, employment status, education, income, the role of social networks, business skills, and fear of failure, and  $\varepsilon_{ij}$  is the error term.

The sample includes five African countries: South Africa, Uganda, Algeria, Tunisia and Morocco. South Africa and Tunisia are in efficiency driven economies group while the remaining countries are in factor driven economies category (GEM, 2009).

Maximum likelihood estimation is used to estimate the models as OLS is an inefficient and heteroscedastic estimator that can predict probabilities outside the unit interval (Maddala, 1983).

In doing so, we followed the set up that Blanchflower (2004), Douglas and Shepherd (2002), Grilo and Irigoyen (2006), Grilo and Thurik (2004), Lin, Picot, and Compton (2000), Wagner (2003) used to test the probability of people to join a certain career path.

Table 4 presents the results of the probit estimation in the form of the probability that an individual has to engage in entrepreneurial work across each demographic variable. The first three columns precluded the variables such as the role of social networks, business skill and fear of failure. The inclusion of these variables, columns 4-6, does show very interesting changes in the qualitative results of some of the variables.

#### **Hypothesis 1: Female are less likely to start an opportunity driven entrepreneurship than male**

According to the estimates, on average, a man are more likely than a woman to engage in early stage entrepreneurial activities. A man is also more likely than a woman to participate in

opportunity entrepreneurship while a woman is more biased to necessity entrepreneurship than a man.

The effect of gender on total early entrepreneurship and opportunity entrepreneurship is however insignificant when we control for the role of social networks, business skills and fear of failure. At this point, we argue that gender difference doesn't matter should both have the relevant entrepreneurial knowledge and skills. To this end policy makers should prioritize ways of developing the knowledge and honing the skills of individuals to bridging the gender gap and spurring entrepreneurial activity.

**Hypothesis 2: Older people are more likely to engage in opportunity-based entrepreneurship**

Older people are less likely to engage in early stage entrepreneurship activities. As explained so far, the results show that they are however more likely to engage in opportunity entrepreneurship. The predicted probabilities in table5 shows a clearer image of the likelihood each age group will engage in early stage entrepreneurial activities. The 18-24 years age cohort has a predicted probability of 0.27 likely to engage in early stage entrepreneurial acts while it was 0.213, 0.214, 0.172,0.122 and 0.126 respectively for the age cohort 25-34, 35-44, 45-54, 55-64 and 65 and above years.

Table 4 Probit Regression Results (Marginal Effects)

Variable	teayy	teayynec	teayyopp	teayy	teayynec	teayyopp
	1	2	3	4	5	6
Male	0.007**	-0.01*	0.02*	0.002	-0.005**	0.01
Age	0.003*	-0.001*	0.002*	-0.002*	-0.001*	0.001*
Not Working	-0.15*	-0.041*	-0.09*	-0.11*	-0.03*	-0.07*
Retired and students	-0.12*	-0.035*	-0.07*	-0.09*	-0.032*	-0.04*
No Education	0.09*	0.049*	0.02**	0.06*	0.04*	-0.001
University Education	0.01	-0.014	0.01	-0.01	-0.01	0.001
Low Income	0.09*	0.047*	0.05	0.06*	0.032**	0.02
Upper Income	0.03*	0.03	0.01*	0.03	0.03	0.01
knowent				0.07*	0.01***	0.05*
suskill				0.12*	0.028*	0.08*
fearfail				-0.01	0.003	-0.01

\*\*indicates the variable is significant at 5% level and \* significant at 1%

**Hypothesis 3: People with low level of education are more likely to become entrepreneurs out of necessity, or**

**People with higher level of education are more likely to become entrepreneurs because of a perceived business opportunity**

Relative to high school education attendees, being in the no education group has a better chance to start business. But when all the variables are included in the regression, their likelihood to participate in opportunity entrepreneurship becomes insignificant and they are more likely limited to necessity based entrepreneurship.

Surprisingly, university education does not bring any meaningful impact on the likelihood of being entrepreneurial; which in fact quests for an overhauling of the education system the countries are implementing at the moment.

The predicted probability to engage in early stage entrepreneurial activity was 0.242 for the no-education ones while it was 0.198 and 0.20 for those who have some secondary education and postsecondary education respectively.

In view of this, the effect of the level of education in explaining entrepreneurial behavior is inconclusive. As highlighted in the descriptive statistics part of the analysis and literature review chapter 1, this can be explained from two perspectives. On the one hand, education increases the opportunity and competitiveness to be employed in salaried employment, there by increases the opportunity cost of pursuing entrepreneurship. On the other hand, education is a key to gain the skills required of an individual to starting a business, thus promotes entrepreneurship. So it is highly critical to identify the nature of education (general education Vs entrepreneurship education) that substantiates and effectuates entrepreneurial mindset of the students (*Chapter 3*).

**Hypothesis 4: People with a better work experience are more likely to become an opportunity-driven entrepreneur compared to people with less work experience.**

The results also indicate those who have work experience are more probable to engage in business than the other groups such as not working, retired and students. The predicted probability to engage in early stage entrepreneurial work for respondents who had work experience was circa 0.29 against 0.094 and 0.109 for not working, and retired and students respectively.

Table 5 Predicted Probabilities

Variable	Margin		
	Teayy	Teaynec	Teayyopp
<b>Education</b>			
None	0.24	.12	.12
Some Secondary	0.20	.07	.13
Secondary Degree	0.19	.04	.14
Post-Secondary	0.20	.03	.16
Graduate Experience	0.11	.02	.08
<b>Work Experience</b>			
Working	0.29	.11	.18
Not Working	0.09	.04	.05
Retired, Students	0.11	.03	.07
<b>Age</b>			
18-24	0.27	.10	.16
25-34	0.21	.08	.13
35-44	0.21	.09	.12
45-54	0.17	.06	.12
55-64	0.12	.05	.07
65 And Above	0.13		.10
<b>Income</b>			
Low Income	0.24	0.09	.15
Middle Income	0.16	0.03	.12
High Income	0.19	0.08	.116

**Hypothesis 5: Low income people start a business out of necessity**

Compared to middle income groups, low income individuals are more likely to engage in early stage entrepreneurial activity. As table5 shows the predicted probability to be engaged in early stage entrepreneurial activity is 0.24 for the low income individuals while it was 0.16 for the middle income groups. Furthermore, the propensity to start business for high income groups, though non-linear and indeterminate, is higher compared to middle income groups: the predicted probability of being engaged in early stage entrepreneurial activity is 0.195. As expected, it is also shown that low income individuals are more probable to participate in necessity-based entrepreneurial activities than middle income groups.

But the result looks different when all the covariates are included in the estimation. Income didn't have a significant effect on the propensity to engage on early stage entrepreneurial activity. Indeed, it is a fact that business knowledge, skills and information an individual has usually takes the driver's seat to conceive entrepreneurial mindset and intention. They precede every other factors



effecting entrepreneurial act. This, in fact works more for taking advantage of the profit due to of starting a firm. As the estimation result in table4 shows, an individual with good business skill and information are more likely to engage in opportunity entrepreneurship. But the very nature of necessity-based entrepreneurs is rarely accommodative of these factors. They oftentimes opt for entrepreneurship not by choice but due to lack of other employment opportunities to sustain a living. As a matter of fact people who have /feels to have the right entrepreneurial knowledge and skills think that getting the financial capital is easier than thought. They believe that they can prepare a project proposal that grab the attention of the lenders to cover the cost the act requires. Hence hypotheses Hypothesis 6: People who have a higher self-assessed business skills are more likely to start a new business and Hypothesis 7: People who have strong social ties are more likely to realize opportunities and start a new business are accepted.

**Hypothesis8: People with a higher fear of failure are less likely to start a new business**

Quite surprisingly, fear of failure is not a significant setback to starting business in these countries, albeit South Africa and Tunisia (Appendix1). In South Africa and Tunisia, fear of failure is likely to deter people from engaging in start-ups. This actually sustains results of previous studies (*Literature Review, Chapter1*) that show fear of failure parallels the level of economic development of a nation. Developing countries cannot basically afford to create sufficient wage employment opportunities compared with developed countries. In regards, despite the challenges ahead people are pushed to opt for entrepreneurship to sustain a living.

#### 4. Concluding Remarks

Findings of the empirical analysis show that the very nature of the entrepreneurial landscape in Africa is a complex one that is hardly specific to some selected people. There is no single recipe to be an entrepreneur. It is explained by a great diversity of individual characteristics such as age, gender, level of education, income, working status, self-assessed business skills and social ties. The descriptive and econometrics analyses asserted that good business skills, knowledge and information that individuals acquire are found to be basic founding blocks to pursue or intend to pursue a career of running their own business. The results also however show that along with work experience, low income and low education individuals are more likely to start a firm. *Ceteris paribus*, it is also evinced that the odds of a man starting a business are quite higher than that of a

woman. Female are more biased to necessity entrepreneurship than male. This also happens to the young, low income, and low educated ones. In fact, when we control for good business skills, knowledge and information, a woman doesn't have a telling difference from a man in the probability to engage in entrepreneurial acts. This thus propels policy makers to focus more on ways to develop and promote the skills and knowledge of women about entrepreneurship.

In addition, though the study doesn't give the full picture of the working of entrepreneurship in Africa, it is also clear that some basic policy goals such as entrepreneurship education should thus step up ways to intriguing entrepreneurship among specific groups of the society such as low income, low educated and the youth, apart from women. As such, the policy focus should be in promoting high growing firms or opportunity entrepreneurs across the whole spectrum of the working age group so that its effect will be meaningful.

Our observation of the statistical analyses showed that education hardly had any clear effect on entrepreneurial act. The result infers that the nature of education in Africa requires an overhauling and continuous assessment in its effect to developing the entrepreneurship intention and mindset of students so that it will be a potent career option for the youth and growing number of graduates that are apparently becoming a pressing policy issue among responsible bodies.

## Chapter 2: Assessment of the Prevailing Business Climate in Sub-Saharan Africa: A Comparative Analysis

2.1 Introduction 2.2 Regulation 2.2.1 Corruption 2.2.2 High Tax Rate 2.2.3 Cost of Income 2.2.4 Getting Credit 2.2.5 Resolving Insolvency 2.3 Infrastructure 2.4 Finance 2.5 Entrepreneurial Knowledge and Skills 2.6 Market Size 2.7 Concluding Remarks

### 2.1. Introduction

The entrepreneurship literature has periodically investigated that the ability of entrepreneurs to thrive in today's dynamic economic system is a reflection of a number of varied multidimensional challenges. It can be examined through the lens of economic, technological, demographic, cultural and institutional variables.

The previous chapter explores the basic demographic variables (micro level) that influence the participation of an individual in an entrepreneurial act. It has just highlighted the entrepreneurial mix Africa embraces.

Of interest in this part of the dissertation is in fact assessing and explaining the existing business climate (macro level) such as laws and regulations, finance, infrastructure, entrepreneurship education and market size.

Our examination of how it determines the pattern of entrepreneurial act in fact draws on existing literature on the same (*Literature review chapter 2*), data availability and the state of entrepreneurial activity in (Sub-Saharan) Africa (*Introduction I*).

A conducive business environment such as over simplified and flexible gives entrepreneurs a rather better chance of flourishing at the lowest possible cost.

When assessed based on this regard, Sub-Saharan Africa lags behind. Our results show that, compared with other regions, we found that cumbersome laws and regulations such as corruption, high tax rate, lengthy and costly procedures are eminently prevalent in the region. The results in the study also show that relatively lack of easy access to reliable and quality infrastructure, most importantly lack of sufficient power is highly challenging and costly to manage for (nascent) entrepreneurs in the region.

The comparative analysis also revealed that, by and large, lack of finance is the biggest and critical obstacle entrepreneurs in the region face. Small loan amount and unparalleled high collateral

complicates the working of entrepreneurship in the region. In fact, lack of entrepreneurial knowledge and skills, and small market size are also relatively smaller than the other regions.

The following section discusses in detail all these issues in a comparative perspective using survey data from Doing Business, Enterprise Survey, World Energy Outlook and some other secondary sources. The data sources are rich enough to evidently analyze the settings of the business climate among the different Regions.

## 2.2. Regulation

Entrepreneurs in Sub-Saharan Africa relatively face quite many tough and complicated regulatory upheavals. As discussed in *Literature Review, Chapter 2*, uneasy regulations wreak havoc the formation of new firms by soaring the time and cost needed to start thereof.

### 2.2.1. Corruption

Incidence of corruption–bribe– is defined as the percentage of firms facing at least one bribe payment request when engaging in different transactions for public services, permits, or taxes. Corruption is one of the serious challenges entrepreneurs in Sub-Saharan Africa face on their way to meet government requirements to start business. The rate of corruption entrepreneurs in Sub-Saharan Africa expected to pay is relatively a huge financial burden. It is higher than the other regions.

The World Bank Enterprise Survey database evidently shows that around 27.8 percent of firms in Sub-Sahara Africa are expected to give gifts to officials to get things done. By contrast in all countries, higher non OECD and higher income OECD, the proportion of bribery incident is lower: 19.4%, 11.6% and 8.4% respectively.

The incidence of corruption is distinctively higher in some countries. The survey data showed that 81.8 % of firms in Republic of Congo, 84.8% of firms in Guinea and 82.1% of firms in Mauritania were expected to give gifts to public officials to get things done.

Having considered the extent of corruption, it is also reasonable to look at the effort government put to control the rather highly prevalent corruption in the region. This basically helps to know if corruption is a long term threat to entrepreneurs and entrepreneurship. Statistics we got from World Bank's Worldwide Governance Indicator database showed that the effort government exerted to control corruption in Sub-Saharan Africa was far behind the other regions. As depicted in figure 11,

Sub-Saharan Africa takes the lowest position in the percentile rankings<sup>2</sup> of the control of corruption compared with Middle East and North Africa, East Asia and Pacific and higher income: OECD. This clearly indicates the tough challenge entrepreneurs in Sub-Saharan Africa face from highly corrupted officials to start a firm and formally operate on it. And it is not something that entrepreneurs in the region can easily escape its effect as long as the effort governments put into reducing it is not really significant.

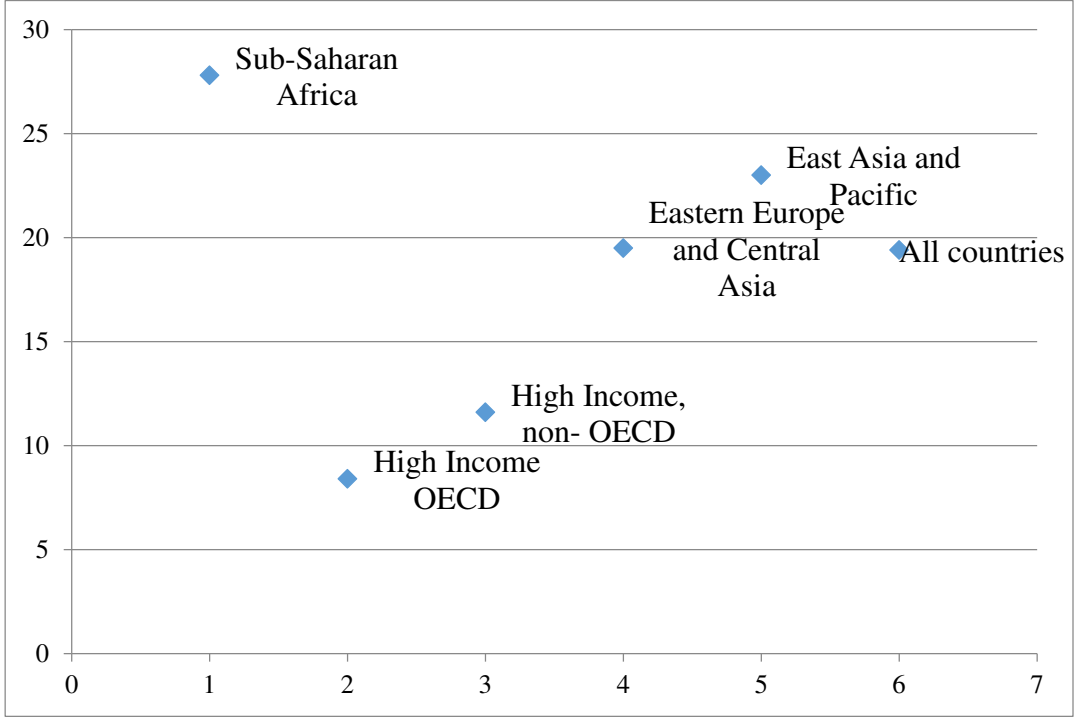

Figure 10 Percent of Firms Expected to Give Gifts to Public Officials to Get Things Done  
 Source: Own Compilation Based on Enterprise Survey Corruption Database

<sup>2</sup> The percentile rankings indicate the rank of a country among all countries in the world. 0 corresponds to lowest rank and 100 corresponds to highest rank.

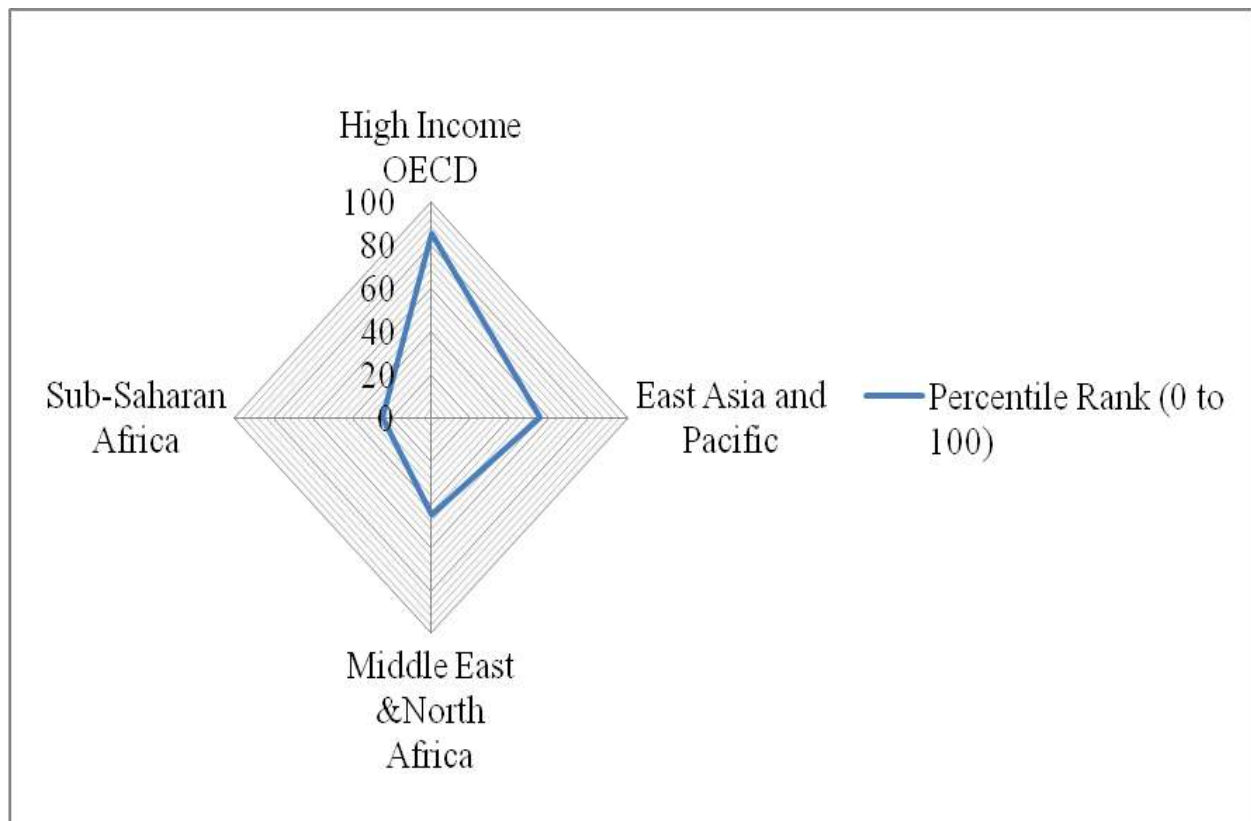

Figure 11 Control of Corruption

Source: Computed based on the World Bank's Worldwide Governance Indicator database 2013.

### 2.2.2. High Tax rate

High tax rate is the other constraining factor entrepreneurs in Sub-Saharan Africa face to successfully contribute to employment and growth. The total tax<sup>3</sup> rate required to be paid by businesses in sub-Saharan Africa is much higher than comparator regions (table6). In Sub-Saharan Africa the total tax rate is 46.2 percent of the profit while it is 34.4%, 34.9%, 41.3% and 39.7% respectively in East Asia and Pacific, Europe and Central Asia, OECD high income and South Asia. It is only better than one region: Latin America and Caribbean.

<sup>3</sup> the amount of taxes and mandatory contributions paid by the business as a percentage of commercial profit that are not already included in the categories of profit or labor taxes

The Paying taxes report jointly published by PwC, the World Bank and IFC built on the World Bank and IFC’s global Doing Business project and the paying taxes indicator with an analysis by PwC, from the point of view of a domestic company<sup>4</sup> complying with the different tax laws and regulations upholds the previous result (figure 12). All the indicators used to assess paying taxes<sup>5</sup> indicate that the second highest average tax cost is in Africa; amounting to 46.6% better only South America where the total tax rate was 55.4%.

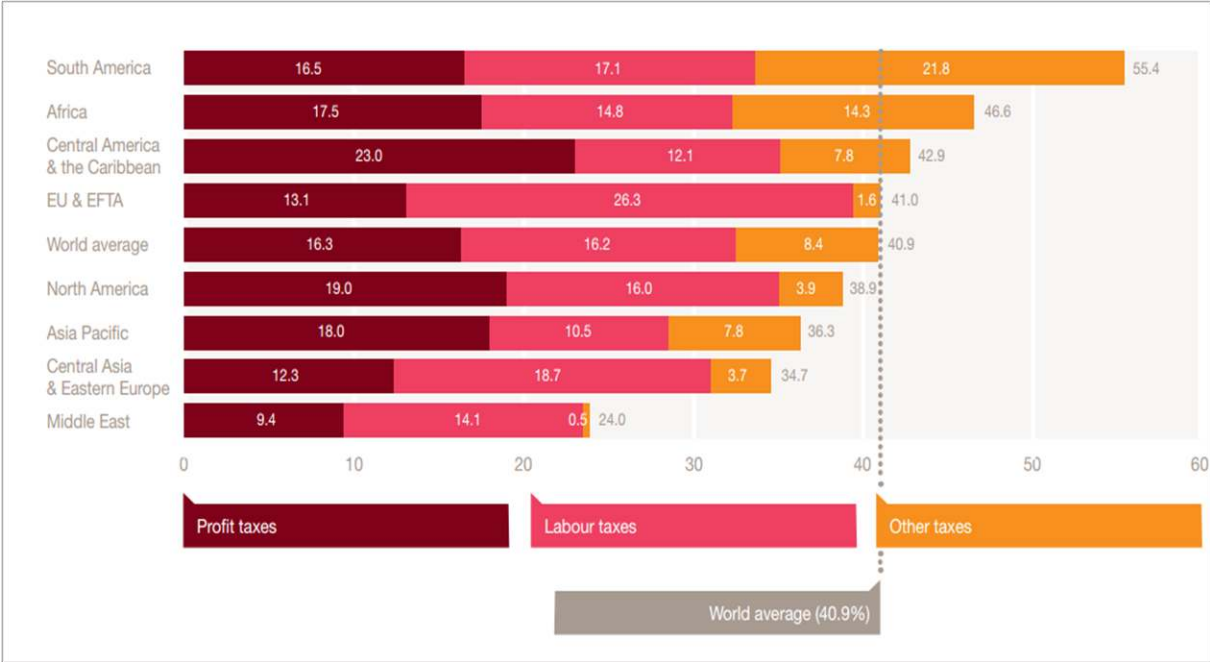

Figure 12 Total Tax Rates by Region

Source: PwC Paying Taxes 2015 Analysis

As a matter of fact, a higher tax rate raises the operating costs so high and in turn jeopardizes the functioning of an entrepreneurial act in a diverse and dynamic economic and social environment. It is quite telling that setting an optimal tax rate substantially helps enterprises, to be more specific small and medium size enterprises, effectively contribute much to job creation, productivity and

<sup>4</sup> The case study company is a small to medium-size manufacturer and retailer, deliberately chosen to ensure that its business can be compared on a like for like basis worldwide.

<sup>5</sup> The paying taxes indicator covers the cost of taxes borne by the case study company and the administrative burden of tax compliance for the company. They are measured using three sub-indicators: the Total Tax Rate (the cost of all taxes borne), the time needed to comply with the major taxes (corporate income taxes, labor taxes and mandatory contributions, and consumption taxes), and the number of tax payments.

growth; even more than it adds to tax revenue. Small and medium enterprises have a clearer insignificant effect on tax revenue (*Literature Review, Chapter2*).

Hence, imposing a huge tax rate on small and medium size enterprises contributes much to business discontinuance and informality per se than generating impactful revenue to the national economy. An equally important issue at this point is the number of tax related documents required of entrepreneurs in Sub-Saharan Africa. Entrepreneurs in Sub-Saharan Africa are often required to deal with more complicated tax related documents. It requires spending the longest hours compared with other regions. Firms in Sub-Saharan Africa spend, on average, 310.8 hours per year to deal with tax-related documents compared with an average high in OECD countries of 175.4 hours, 204.3 hours in East Asia and Pacific, and 234.3 hours in Europe and Central Asia (table6). It is only better than two regions South Asia and Latin America and Caribbean respectively 325.3 hours and 365.8 hours.

### 2.2.3. Cost of Income

The cost of income required by law to start a business<sup>6</sup> is also quite problematic. As depicted in table6 the cost required by law to start business in Sub-Saharan Africa is the highest of other regions. It was 56.2% of income per capita compared to, for instance, 5.3 Europe and Central Asia, and 4.8% OECD high.

Entrepreneurs in Sub-Saharan Africa also face a considerable difficulty registering property. As shown in table6, registering property in the region requires the uppermost income per capita. The cost of registering property in Sub-Saharan Africa (SSA) costs 9.1 percent of the property value whilst it is 4.5 percent and 4.2percent respectively in East Asia and Pacific and OECD countries.

---

<sup>6</sup> Starting Costs, captures all official fees and additional fees for legal and professional services involved in incorporating a business, and is measured as a percentage of the economy's income per capita



Table 6 Doing Business Indicators

Indicator	EAP <sup>7</sup>	ECA <sup>8</sup>	LAC <sup>9</sup>	MENA <sup>10</sup>	OECDhigh	SA <sup>11</sup>	SSA <sup>12</sup>	
Procedures (Nos.)	7.3	5.0	8.3	8.0	4.8	7.9	7.8	
Time(days)	34.4	12.1	30.1	18.9	9.2	16	27	
Cost(% of income per capita)	27	5.3	31.1	28.1	3.4	14.6	56.2	
Paid-in-min. capital(% of income per capita)	256.4	5.8	3.2	45.6	8.8	14.2	95.6	
Total tax rate (% Profit)	34.4	34.9	48.3	32.6	41.3	39.7	46.2	
Time spent to pay taxes(hrs/yr)	204.3	234.3	365.8	220.4	175.4	325.3	310.8	
Public registry coverage (% of adults)	11.0	19.3	12.6	8.7	12.1	3.2	4.5	
Private bureau coverage(% of adults)	20.4	33.7	39.3	11.6	67.0	11.3	5.8	
Cost of bankruptcy proceeding (% of estate value)	21.8	13.3	16.4	13.9	8.8	10.1	23.3	
Recovery rate (cents/dollar)	36.8	37.7	36.0	34.0	71.9	36.2	24.1	
Registering property	Procedures(N)	5.2	5.4	7.0	6.1	4.7	6.4	6.3
	Time(days)	77.9	23.1	63.3	31.3	24.0	99.5	57.2
	Cost(% of property value)	4.5	2.7	6.1	5.7	4.2	7.2	9.1

Source: Compiled Based on World Bank Doing Database 2015

*Note that: green colour shows starting business indicators, yellow colour shows Tax rate, red colour shows Credit and resolving insolvency issues, and the grey colour shows registering property.*

<sup>7</sup> East Asia and Pacific

<sup>8</sup> Europe and Central Asia

<sup>9</sup> Latin America and Caribbean

<sup>10</sup> Middle East and North Africa

<sup>11</sup> South Asia

<sup>12</sup> Sub-Saharan Africa

#### 2.2.4. Getting Credit

Similarly getting credit<sup>13</sup> is far more difficult. Grounded on the measures the World Bank doing business has used for the same– strength of legal rights index<sup>14</sup>, depth of credit information index<sup>15</sup>, public registry coverage<sup>16</sup> (% of adult) and private bureau coverage<sup>17</sup> (% of adults)– Sub-Saharan Africa posts the minimum value; surpasses only South Asia. When it recorded 4.5 percent and 5.8 percent in public registry coverage and private bureau coverage, OECD high income, and East Asia and Pacific recoded respectively 12.1 percent and 67 percent, and 11.0 percent and 20.4 percent.

#### 2.2.5. Resolving Insolvency<sup>18</sup>

It is also one of the fundamental challenges entrepreneurs face difficulty engaging in entrepreneurship.

The average cost of bankruptcy proceeding<sup>19</sup> in Sub-Saharan Africa is the highest while the recovery rate is the lowest of all the regions. In Sub-Saharan Africa the average cost of bankruptcy proceeding is 23 percent of the estate value while it is 9 percent and 10.1 percent in OECD high income and South East Asia respectively. On the contrary, the recovery rate<sup>20</sup> in Sub-Saharan Africa is 24.1 cents for one dollar where as it is 71.9 and 36.2 cents for one dollar in OECD high income and East Asia respectively. This actually shows getting a second chance for business failure is almost impossible. Thus worsens the challenges firms in the region face due to the very expensive starting costs.

---

<sup>13</sup> Explores two issues- the strength of credit reporting systems and the effectiveness of collateral and bankruptcy laws in facilitating lending

<sup>14</sup> Strength of legal rights index (0-10) measures the degree to which collateral and bankruptcy laws protect the rights of borrowers and lenders and thus facilitate lending.

<sup>15</sup> Depth of credit information index(0-6) measures rules and practices affecting the coverage, scope and accessibility of credit information available through either a public credit registry or a private credit bureau

<sup>16</sup> Public registry coverage(% of adults) reports the number of individuals and firms listed in a public credit registry with information on their borrowing history from the past 5 years

<sup>17</sup> Private bureau coverage (% of adults) reports the number of individuals and firms listed by a private credit bureau with information on their borrowing history from the past 5 years.

<sup>18</sup> Resolving insolvency identifies weaknesses in existing bankruptcy law and the main procedural and administrative bottlenecks in the bankruptcy process.

<sup>19</sup> Cost (% state) -the average cost of bankruptcy proceedings. The cost of the proceedings is recorded as a percentage of the estate's value.

<sup>20</sup> The recovery rate calculates how many cents on the dollar claimants (creditors, tax authorities, and employees) recover from an insolvent firm.

### 2.3. Infrastructure

Enabling infrastructure is one of the fundamental ingredients to thriving entrepreneurship. It is the base to exercising an entrepreneurial knowledge and harnessing the state of innovation in a nation. Easy access to reliable and quality infrastructure lowers transaction costs, better access to markets, increases efficiency, productivity and growth.

Entrepreneurs in Sub-Saharan Africa have long been struggling with a low stock of infrastructure in their day to day activity.

**Lack of sufficient power** is one of the menaces that thwart entrepreneurs in Sub-Saharan Africa to starting and growing business. Many businesses lack reliable power supply to operate higher value added activities that heavily depend on electricity-based technologies. Evidence shows that Sub-Saharan Africa has the lowest electrification rates in the world. According to the world energy outlook's (2014) special report in Sub-Saharan Africa, only 290 million out of 915 million people have access to electricity. The rate of access to energy in sub-Saharan Africa accounts only to 32% of the population though there has shown improvement from its 23% level in 2000. In regards, two-thirds or so of the population lives without electricity.

Undoubtedly, limited electricity has an impairing effect on firm functionality. Insufficient and poor power supply critically jeopardizes the optimal production of a firm. As indicated in table 7, on average 4.9% of annual sales in Sub-Saharan Africa were estimated to be lost due to electrical outages against 2.5% for the world average. The number of electrical outages in a typical month was 7.8 compared with 5.5 for the world.

To deal with such unreliable supply of electricity, self-generated electricity or captive power generator has become an increasingly appreciable and important source of power; 45.8% of firms in Sub-Saharan Africa own or share a generator against 33.1% the world average.

But the cost of using back-up power generation to mitigate poor grid-based supply is such an expensive option for start-ups to afford to buy. In 2012, the cost of fuel for back-up generation (across businesses and households) is estimated to have been at least \$5 billion (Africa Energy Outlook, 2014).

Table 7 Infrastructure Challenges to Entrepreneurship

Economy	Percent of firms identifying electricity as a major constraint	Number of Electrical outages in a typical month	Proportion of electricity from a generator (%)	Percent of firms owning or sharing a generator	Losses dues to electrical outages (% of annual sales)
All Countries	33.6	5.5	7.4	33.1	2.5
East Asia & Pacific	22.6	3.5	7.2	36.1	1.6
Eastern Europe & Central Asia	17.9	2.0	2.5	21.3	1.2
High income: non OECD	31.1	1.3	1.6	22.4	0.3
High income: OECD	21.8	0.4	0.4	13.1	0.1
Sub-Saharan Africa	44.8	7.8	12.6	45.8	4.9

Source: Compiled Based on Enterprise Survey: Infrastructure Database

The dearth of other infrastructures such as road also poses a massive barrier to start-up growth in the region. Sub-Saharan Africa falls short of all season roads to transport products to the market place. By way of comparison, the region managed to make only 318000 km of paved roads that is equivalent to around two-thirds of Italy’s figure (Africa Energy Outlook, 2014). This drives up the transport cost and impose a huge impairment to entrepreneurial activity in the region. In this regard, as Juma (2011) indicated the transport cost on clothing export in Uganda was equivalent to 80 percent tax on the item. Consequently, infrastructure challenge has already been a productivity trap in many Sub-Saharan Africa countries.

#### 2.4. Finance

Financial problem has long been one of the stout challenges entrepreneurs in Sub-Saharan Africa faced along the years. They put inadequate fund as the biggest and critical hurdle to starting a firm and compete with incumbent firms.

Based on the World Bank Enterprise survey database, loan amount and the value of collateral required of entrepreneurs prevent many of them funding their start-up firm. As indicated in table8,

it turned out that 41.6% of firms responded to the survey revealed access to finance as a major constraint in pursuing entrepreneurial work compared with 28.6% of the global average.

Table 8 Access to Finance

Economy	Percent of firms identifying access to finance as a major constraint	Proportion of loans requiring collateral (%)	Value of collateral needed for a loan (% of the loan amount)
All Countries	28.6	77.4	193.9
East Asia & Pacific	16.7	79.8	201.2
Eastern Europe & Central Asia	17.1	82.8	205.6
High income: non OECD	26.0	76.0	180.3
High income: OECD	12.8	65.5	157.4
Sub-Saharan Africa	41.6	79.3	173.8

Source: Compiled Based on Enterprise Survey Finance database

In fact without adequate finance, proper functioning and growth of firms is a complicated nightmare. Lack of finance makes the opportunity cost of getting loan much higher for entrepreneurs. They are required to present much higher levels of collateral for lenders. A great deal of entrepreneurs in Sub-Saharan Africa revealed that it is not uncommon to face a disproportionate amount of collateral request from financiers; 79.3% of firms in the region indicated that lenders require collateral which actually is still higher than the global average of 77.4%. The value of collateral needed for a loan (% of the loan amount), though relatively lower than the global average, is quite high for new firms. Lenders in Sub-Saharan Africa require 173.8% of the loan amount compared with 193.9 % of the global average (table8).

In regards, most firms in the region cannot manage to get sufficient credit to start a firm. More than 59 percent of entrepreneurs fail to get credit required for starting firms<sup>21</sup> compared to 31 percent in Eastern Europe and Central Asia, and 34 percent in Latin America and the Caribbean (figure 13). Compared to large firms, entrepreneurs, surrogated by small firms, are more likely to be credit constrained. The probability of credit constrained decreases with firm size. By way of example,

<sup>21</sup> Most entrepreneurs in Sub-Saharan Africa are small enterprises that have 20 and less employees.

when 59 percent of small firms in Sub-Saharan Africa are credit-constrained, it was only 43 percent and 30 percent respectively of medium and large enterprises that are credit constrained (figure 13).

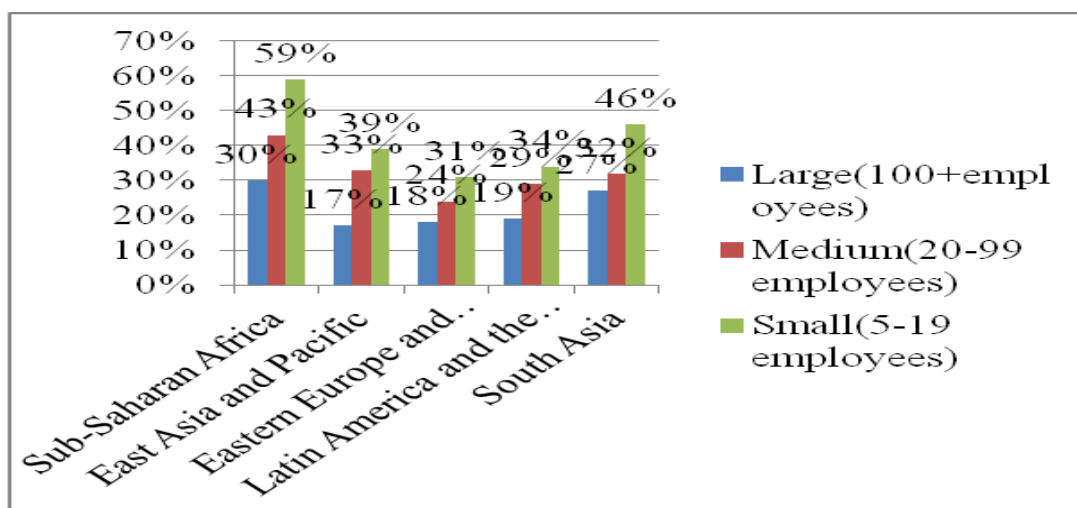

Figure 13 Credit-Constrained Firms by Size and Region

Source: Computed based on World Bank Enterprise Surveys

## 2.5. Entrepreneurial Knowledge and Skills

In chapter one our results show that general education doesn't bring about a clear cut effect on the stock of entrepreneurial knowledge and skills that are fundamental for a promising entrepreneurial work by enthraling self-confidence and self-efficacy of someone to cope with the inevitable challenges (nascent) entrepreneurs face ahead. Entrepreneurial knowledge and skills are also critical to develop a good project proposal and secure a great pool of finance required to start a viable firm, which in fact was a big challenge that lenders never get an answer to give loan for entrepreneurs (*Literature Review, Chapter2*).

This didn't look to happen for entrepreneurs in Sub-Saharan Africa. The percentage of entrepreneurs who believe that they are capable of running a successful entrepreneurial work is quite small. For instance, the percentage of entrepreneurs who believe that they have the right skills to work on new firms is 9 percent in South Africa, 14percent in Ghana and Nigeria, 19percent in Ethiopia; 22percent in Tanzania and 23percent in Kenya (Omidyar Network, 2013).

Surprisingly, many countries in Sub-Saharan Africa have already started the course in their higher education institutions. A recent study on the status of entrepreneurship education in higher

education institutions in the region demonstrated that over 86 percent of them started to offer courses in entrepreneurship (Kabongo, 2010).

Nevertheless a thorough examination of entrepreneurship education shows that the rigor and relevance of entrepreneurship training programs are doubtful (*more explanation on chapter 3*). The targets, the course content, course delivery, R&D programs and centers for entrepreneurship development face critical issues.

The course is of discriminatory in nature. It is beyond usual to teach entrepreneurship courses only to business and economics majors. Apart from that it is also clearer that conventional teaching and evaluation methods are such a norm in African universities entrepreneurship course delivery. In this regard, Dugassa (2012) noted that the system much highly focuses on theory and lacking skills required for critical thinking, decision making, teamwork capacities, risk taking and starting businesses. Kannan (2012) sustained the same point. In his study on the status of entrepreneurship education in Ethiopian higher education institutions, he revealed that all the professors and 88% of the students believed that entrepreneurship courses currently delivered in higher education institutions lack practical content, interactive classrooms or experiential learning. What's more, most professors have not been trained in entrepreneurship— by and large they come from departments like business management and economics. Consequently, most universities have not yet started entrepreneurship as a concentration (Kaijage and Wheeler, 2013).

In the same breath entrepreneurship development and research centers are not alluring. Only 7 percent of institutions have had entrepreneurial centers devoted to entrepreneurial development (Omidyar Network, 2013). Moreover, of the 57 colleges and universities Kabongo (2010) included in his study, only 10% of them had a course in innovation and technology.

In this aspect, the *Times Higher Education* World University Ranking 2014/15 based on teaching quality, research activities, knowledge transfer and international outlook affirmed this fact. For example, within the rank order of 101-400, only three universities—University of Cape Town (124<sup>th</sup>), University of Witwatersrand (251-275) and Stellenbosch University (276-300) are from Africa. This apparently points out that most African universities are far off the pitch of innovation. The low ranking of Sub-Saharan Africa countries in the Global Innovation Index 2013—based on indicators of innovation and enablers to innovation shows also the same. Out of 142 countries only two countries (Mauritius and South Africa) achieved the rank below average.

In effect, startups in the region are uncompetitive and of same sort so much that some writers call them the “me too” businesses. According to GEM (2009) survey, only 7% of Ugandan entrepreneurs revealed that they have no business competitors against 73% that have disclosed the presence of many business competitors.

## 2.6. Market Size

Big and growing markets give entrepreneurs the opportunity to easily take advantage of the shortages that firms already in the market cannot satisfy. Big markets have a huge cost for entrepreneurs by providing greater opportunity for scale economies.

When Sub-Saharan Africa is assessed on this basis, market size—proxied by Intra Sub-Saharan African Trade—is not that much encouraging to entrepreneurs. It is still in its early stage for entrepreneurs to capitalize the growing population in the region. According to the United Nations Conference on Trade and Development (2013), over the period 2007 to 2011, the average share of intra-African exports in total merchandise exports in Africa was 11% compared to 50% in developing Asia, 21% in Latin America and the Caribbean, and 70% in Europe.

## 2.7. Concluding Remarks

Entrepreneurship has recently been taking the center stage of innovation, job creation, poverty reduction and growth in Africa. Fostering it has become a key component of policy goals and initiatives. Many countries have continuously undertaken business regulatory reforms, provide entrepreneurship education and also incorporated entrepreneurship growth policies in their long term strategic plans. However, despite such efforts, the study evidently shows still there is a big room for improvement. Firm growth rate and job creation prospects are yet at a relatively infancy stage. At the same time regulatory quality and entrepreneurial act promoting tools like entrepreneurial training are considerably short of sufficient, not to forget small market size.

Accordingly, in order to capitalize the unparalleled importance entrepreneurship can bring to African economy; a lot is expected of responsible bodies. In this regard, we forwarded the following policy recommendations:

- The countries need to implement an optimal level of business regulation to successfully drive up entrepreneurship growth. Business regulatory reforms shouldn't be just a one-off incident alike election campaigns. Reforms should be flexible enough and timely to



accommodate the dynamicity in the economy and effectuating the objectives set aside of entrepreneurship.

- Entrepreneurship education in Africa doesn't look fully-grown to create a strong entrepreneurship ecosystem and tackle the growing youth unemployment dilemma. From the very start, it faces huge problems in its delivery. Conventional teaching methods are employed by most higher education institutions. Equally important, not all though, it precludes students from non-business and economics fields. In light of this, entrepreneurship education program should be holistic in its target.

Entrepreneurship courses need to be developed and integrated across disciplines apart from business and economics fields to instill entrepreneurship awareness in the minds of students to make it as a career option for prospective school leavers and graduates.

Furthermore, the course delivery needs to be innovative and experiential. In this regard, there is a profound need for a greater use of experiential and a new coach/ moderator role for teachers which helps students to become more independent and to take the initiative in their education. In addition, changes in the education context such as taking students out of the classroom into the local community and real businesses, and which establishes less hierarchical relationships within schools.

Besides, the “who” to teach of entrepreneurship requires a serious revision. In this sense, countries are required to work more on staff development that offers entrepreneurship course.

- The secondary data analysis above revealed finance as the greatest hurdle entrepreneurs in Sub-Saharan Africa face. Diversifying the sources of finance and the ways to access them can be a huge boost to entrepreneurial work. An availability of ranges of sources of finance decreases the risks of failure to new firms in the market.
- As infrastructure has a great impact on the overall process of an entrepreneurial activity- from production to marketing, its development should also be a high priority on the tables of the responsible bodies.
- Enhancing regional integration is also a lively means to encourage entrepreneurs for innovation and productivity with the aim of satisfying a big market.
- Finally, there should have to be a rigorous and continuous assessment of the impacts entrepreneurship development initiatives and programs have on entrepreneurial activity.

This shows policy makers and government to know the maximum level of intervention required of them for a successful venture formation. It also helps them manage the resources to be allocated to entrepreneurship development programs. The study also posits the need for a more robust study to clearly know the amount of disruption the challenges caused on entrepreneurial work.

## Chapter 3

# The Role of Entrepreneurship Education on Intention towards Entrepreneurship

3.1 Introduction 3.2 Data and Methods 3.2.1 Sample Description 3.2.2 Questionnaire Development 3.2.3. Operationalization of the Constructs 3.2.3.1 The Independent Constructs 3.2.3.2 The Dependent Construct 3.2.3.3 Control Variables 3.2.4 Data Collection Procedure 3.2.5 Data Analysis Procedure 3.2.6 Pre-analysis Tests 3.2.6.1 Check for Biases 3.2.6.2 Tests of Variables 3.2.6.3 Validation of the Measurement Scale 3.3 Results and Discussion 3.3.1 Descriptive Analysis of the Data 3.3.1.1 Characteristics of the Participants 3.3.1.2 The Effect of Demographic Variables on Students' Perception to Entrepreneurship 3.3.2 Hypotheses Testing 3.3.2.1 Structural Equation Modeling(SEM) 3.3.2.2 Testing the Relationship between Entrepreneurship Education and Intention to Entrepreneurship: Difference-in-Difference Approach 3.4 Conclusion and Implication of the Study

### 3.1. Introduction

In recent years, entrepreneurship has predominantly become part of the fabric of every society. It turns out to be a potent instrument to tackle unemployment, drive innovation and catalyze economic growth.

This has triggered an extensive shift in the policy efforts of governments around the world towards enthralling entrepreneurship. One of the substantial pro-entrepreneurship policies consists of entrepreneurship education programs that aim to develop knowledge and hone skills that enable an individual to navigate the rough and rugged road facing entrepreneurs, given the central premise that entrepreneurship education is a learned phenomenon.

To this end, entrepreneurship education has been mushrooming all over the world at all levels of the education system; most importantly at colleges and universities. The number of entrepreneurship courses in the US increased tenfold in the period from 1979 to 2001 (Katz, 2008). A concomitant rise in entrepreneurship courses and professions has also been observed all over the world. Study by Jean (2010) on the status of entrepreneurship education in higher education institutions, for instance, demonstrated that over 86percent of universities in Sub-Saharan Africa have instituted a wide range of entrepreneurship education efforts.

The fundamental question accompanying this proliferation has then been whether or not entrepreneurship education programs are effective in enabling an individual to become entrepreneur. It has faced questions of legitimacy. The impact of entrepreneurship education has

thus become a subject of much discussion among entrepreneurship scholars. Has entrepreneurship education and research been so impactful?

Review of entrepreneurship literature showed that the real impact of entrepreneurship education has remained largely unexplored and thinly understood. There has still been little rigorous research on its effects. Of course, our preliminary assessment of previous studies evinced an overly positive impact of entrepreneurship education courses or training programs on perception to entrepreneurship. Around 86% of the studies (49 out of 57) indicated a positive result with the remaining 8 studies evidenced negative or insignificant result (*Literature Review, Chapter3*).

Nonetheless, perusal of the studies that reported positive impact of entrepreneurship lack methodological rigor that limited the validity of the results.

First, most studies are mainly ex-post examinations that fail to measure the direct impact of entrepreneurship education program. Our observation of the 49 studies gave evidence that 73.5% (36 studies) employed ex-post design.

Second, they lacked any comparable control groups or stochastic matching to understand the change on the experimental group. It is considered that around 63.3% (31/49 studies) failed to include control groups in their research design. In this case we cannot exclude the possibility that the participants updated their perception to entrepreneurship based on information that was extraneous to the course.

Third, we also realized that though there had been some studies that followed pre- post design with control groups, they struggled with insufficient sample size. For instance, out of the 6 studies that revealed positive result and applied a pretest-posttest analysis with control group, only two studies (Souitaris et al., 2007; Peterman et al, 2003) had engaged an experimental group with more than 100 samples.

Fourth, the majority of previous studies have been conducted in economies at advanced stages of development, with quite limited focus on least developed countries. The preliminary assessment once again indicated that out of the 57 studies overviewed only 4 were on least developed countries. Finally, the studies were not apparently inclusive. Most entrepreneurship impact studies have been sampling only business and economics students. Non-business students such as natural science and engineering students have not been the focus of previous studies, save the fact that this group represents the bulk of entrepreneur society all around. Studies from the latter group were very few. The literature survey unveiled that less than 10% (5 studies) sampled engineering students.

This part of the dissertation was therefore framed to fill the gaps with regard to the impact of delivering entrepreneurship education on entrepreneurial behavior. In doing so, we conducted pretest-posttest design using a compulsory entrepreneurship course for engineering students at Debre Berhan University, Ethiopia.

We took in to account the entrepreneurial intention of students instead of their actual entrepreneurial behavior. Someone's intention to carry out (or not carry out) a behavior is essentially considered as the best predictor of planned behavior (Bird, 1988; Ajzen, 1991; 2005). It is also evident that entrepreneurial activity is reckoned as intentionally planned behavior (Krueger et al., 2000). To this end, entrepreneurial act is likely to proceed the formation of entrepreneurial intention.

In light of this, we argue that understanding the relationship between entrepreneurship education and intention is a priority to gain clear insight about education-entrepreneurship relationship. Among the classes of intention models, the theory of planned behavior was chosen as the conceptual model for the study. It was found parsimonious, robust and replicable to predict entrepreneurial behavior through intention (*Literature Review, Chapter3*).

The results of the study indicated that entrepreneurship course has a significantly positive effect on students' entrepreneurial intention. This was reflected by the fact that the change on entrepreneurial intention for the entrepreneurial group was much higher than for the control group students. At the same time, we also learned that the change in intention among the entrepreneurial group was but dependent on the initial level of intention. Students who were already at a higher level of intention show smaller improvement than students who had been at a lower intention level prior to the course which in fact gives a good reminder to entrepreneurship educators to be cautious about the type of entrepreneurship education they provide for students.

Our contribution is based on some defining characteristics. To the best of our knowledge, this is the first study that look at the effects of entrepreneurship education on engineering university students in Ethiopia. Existing studies all but sample students from business and economics streams. There were also no previous studies that employed pre-post analysis with control group.

The remainder of this paper is structured as follows. First, we review the pertinent methodological procedures to be able to answer the research question. Then, we report the results and give a detail discussion on the results of the study. Finally, it concludes and provides some insight on the implications, and limitations of the study with some suggestions for future research.

## 3.2. Data and Methods

This section presents a discussion about the pertinent methodological procedures used to be able to answer the research questions. It attempts to characterize the research design used in the study, target population, sampling and data collection procedures. It also explains the set of statistical methods used to analyzing the data.

### 3.2.1. Sample Description

The effectiveness of an entrepreneurship education program in reaching its stated objectives requires a systematic analysis of the effects it has on the various proxies for entrepreneurship such as on the participants' attitude, subjective norm, perceived behavioral control and then on entrepreneurial intention.

In doing so, we took a sample of 270 engineering students from Debre Berhan University; one of the thirteen universities established in 2007 by the Ethiopian government.

To calculate the sample size we applied the most simplified, popular and commonly practiced method provided by Yamane (1967) as:

$n = \frac{N}{1+N(e)^2}$ , where n is the sample size, N is the population size, and e is the level of precision.

The students were in their fourth year of the five year program. The sample consisted of two groups of students, such as students who were taking an entrepreneurship course and those who were not taking the course (the control group) at the time of the survey.

The entrepreneurship group comprised of 150 civil and construction engineering department students while the control group students consisted of 120 mechanical and electrical engineering students.

The impetus behind selecting engineering students as our unit of analysis paralleled the works of Souitaris et al (2007), and the contexts of the country, that is Ethiopia.

a. The students already have had technical training that gives them a clear comparative advantage to start high-growth technology firms. Alike the other natural science stream students, they are more suited to develop new applications and product ideas than social science fields. They get interesting and creative ideas for how to create values through enterprise, yet feel frustrated because they understand so little about the enterprise creation process. Graduating only with technical training doesn't suffice to gain insights about starting

a firm. Stock of entrepreneurial knowledge and skills are of very high importance to effectuate pursuing of new firms.

b. The entrepreneurial attitudes and intentions of technical students are unlikely to have been affected or contaminated by prior business courses that touch up on entrepreneurship. As outlined in *Literature Review, Chapter3*, the number of entrepreneurship impact studies on students in the fields of engineering and technology was quite few. Of the 57 studies summarized in the literature only 5 of them were from engineering and technology fields.

This is actually against the fact that most investors and entrepreneurs overwhelmingly come from engineering and technology backgrounds. For instance, 71% of the 21<sup>st</sup> century top entrepreneurs are engaging themselves in the technology area (*Literature Review, Chapter3*). Empirical evidence abounds that entrepreneurs are not educated in business schools. Wheeler's (1993) survey reported that science majors had a higher propensity to become entrepreneurs (47%) than business majors (35%). 77% in one survey of small business owners (Schweitzer, 2007), and more than 80% of college-educated Inc. 500 company founders in another (Bhide, 2004) were from non-business schools. The results were supported by Wu and Wu (2008) that engineering students had higher entrepreneurial intentions than business administration, economics students and other non-business related students (such as those majored in history, medicine, psychology, geography & law). Therefore, it is valuable to pay more attention to engineering entrepreneurship education and investigate what factors influence the entrepreneurial intention of these students and how these factors should be considered in curriculum design. This triggers the need for further impact studies in the field of engineering.

c. Most importantly the current education policy of Ethiopia primarily focuses on ramping up the number of university graduates in engineering, technology and natural science streams. Ethiopia adopted a policy of 70:30 universities in take ratio in favor of science and technology (FDRE, 2010). This predictably will stiffen the competition among graduates in the jobs market. The position science and technology graduates can fill will also decrease through time. At this junction, students that have better entrepreneurial knowledge and skills can start to realize entrepreneurship as a viable career option for the slack labor market.

Hence, assessing the impact entrepreneurship education has on the entrepreneurial intention of students is of great importance to manage resource flow to science and technology fields.

The course lasted for 4 months and it was mandatory for 4<sup>th</sup> year civil and construction engineering students. And it was offered by one professor.

The course was an awareness creation entrepreneurship education designed to introduce students to the concept of sustainable entrepreneurship. It aimed to provide a comprehensive entrepreneurship knowledge, skills and attitude for students to take the blinders off and consider entrepreneurship as a viable career option. It was designed to equip students with the tools and inspiration required of them to start and grow a successful business. The course incorporated introduction about entrepreneurship and entrepreneur, and the identification of entrepreneurial opportunities. The elements of creative problem-solving, the development of a business concept/ model, the examination of feasibility studies, and the social, moral and ethical implications of entrepreneurship were covered. This course was also directed toward forging views of entrepreneurship as they operate in today's world.

In the teaching process, the professor used interactive and creative methods of teaching such as lecture, group and individual projects such as developing business plan and the like that could help them develop a favorable attitude toward entrepreneurship and intention to venture creation.

### 3.2.2. Questionnaire Development

We used self-reporting structured questionnaire following a thorough procedure to ensure reliable and valid instrument with appropriate scales (Appendix2). For that, we surveyed extant literature on the constructs of the theory of planned behavior and entrepreneurship intention. Then we developed the basic questionnaire consistent with the objects of the dissertation study and the dimensions of the theory of planned behavior. The questionnaires for the two groups of students (entrepreneurial and control groups) were exactly the same.

A brief introduction highlighting the objectives due to of the dissertation was attached to each questionnaire. It provided a short background to the study, contact details and name of the supervising professor. It also reminded the students that the questionnaire would be coded to render anonymity.

We confirmed the credibility of the measurement instrument and our data by conducting reliability and validity tests (section 3.2.5.3). The questionnaire has 30 items in total.

The first section of the questionnaire measured demographic characteristics of the respondents such as age and gender of the respondents, parents' occupation (father self-employed, mother self-



employed), socio economic level (Father's level of education, Mother's level of education, Income level), and start-up experiences of the students (it entails if respondents have worked in small enterprises or even start-ups in combination with their assessment of positive or negative experiences associated with their work).

The second section presents the entrepreneurship education experience of the respondents of the survey. It reflects the students' level of entrepreneurial knowledge that enquires the students' previous experience in entrepreneurship trainings and the respective entrepreneurial skills and knowledge.

Section three provides a brief description of the relevance of the course in shaping the attitude towards entrepreneurship, subjective norm, and perceived behavioral and entrepreneurial intention of students.

The next section presents the measures of each of the constructs of the theory of planned behavior.

### 3.2.3. Operationalization of the Constructs

The survey questionnaire regarding the constructs of the theory of planned behavior employed for this study utilized validated scale measures. The measures we used for the survey emanated from validated scales that were used in past research. Taking this in to consideration, we employed multiple item-scales as a measure of the constructs.

The importance of multiple-item measure over single-item measure has already been well-documented over many instances (Bryman, 2008; Boyd, Gove and Hyatt, 2005 DeVellis, 2003; Armitage and Conner, 2001).

In light of the above, we developed three basic reasons to prioritize multiple-item measure over single-item one:

For one thing, multiple-item question measures every single entity and then unfolds all the aspects of the underlying concept. On the contrary, the single-item measure may incorrectly classify many individuals for some possible reasons, such as incorrect wording of the question or misunderstanding. Multiple-item measure helps to average out such errors and specificities inherent in single-items. This allows more accurate computation and leads to increased reliability and construct validity. Thus it has a stronger predictive power than the single-item measures.

We used a 7-point Likert scale for each of the constructs; which is the most frequently used sort of summated rating scale (Cooper & Schindler, 2003). Students were asked to agree or disagree with each statement or indicate the extent of their feeling to each statement.

The points 1-7 indicate the value to be assigned to each possible answer with 1 representing the least favorable impression of issues pertaining to entrepreneurship while 7 representing the most favorable ones (Tung, 2011).

The section here in below discusses the measures of the constructs of the entrepreneurial intention model.

### 3.2.3.1. The Independent Constructs

Based on literature review, chapter3, we identified 3 main independent constructs such as attitude towards entrepreneurship, subjective norm and perceived behavioral control.

#### **Attitude towards Entrepreneurship**

Attitude towards entrepreneurship refers to the degree to which a person has favorable or unfavorable evaluation of performing the behavior of becoming an entrepreneur. Researchers have long used range of scales to measure attitude towards different behaviors.

Krueger et al. (2000) used an aggregate scale to measure attitude towards entrepreneurship to study the relationship between attitudes and entrepreneurial intention. They used a single question “Is starting your own business an attractive idea to you? (Scale: 0-100)”. On the other hand, Kolvereid and Isaksen (2006) used a mixed-scale (beliefs and aggregated). They treated beliefs and attitudes as two independent variables, and entrepreneurial intention as the dependent variable. The beliefs were measured using four belief measures of self-employment already identified by Kolvereid (1996): autonomy, authority, economic opportunity and self-realization. The aggregate attitude was measured by 4 items: (1) I would rather own my own business than earn a higher salary employed by someone else. (2) I would rather own my own business than pursue another promising career. (3) I am willing to make significant personal sacrifices in order to stay in business. (4) I am willing to work more with the same salary in my own business, than as employed in an organization. The results showed that no significant relationship was established between beliefs and entrepreneurial intention. However, the aggregate attitude significantly predicted entrepreneurial intention.

In view of this, an aggregate measure of attitude towards entrepreneurship is more appropriate than the belief measure. Hence, we adopted the aggregate attitude scale for this dissertation. For that we

used a 7- point Likert –type scale used by Liñán (2009) as a measure of attitude towards entrepreneurship.

These items capture if a student has a favorable or unfavorable attitude towards creating his or her own business.

A1: Being an entrepreneur implies more advantages than disadvantages to me

A2: A career as entrepreneur is attractive for me

A3: If I had the opportunity and resources, I'd like to start a firm

A4: Being an entrepreneur would give me great satisfaction

A5: Among various options, I would rather be an entrepreneur

### **Subjective Norm**

Subjective norm, consistent with the literature denotes the chance that significant referents (such as parents and friends) with whom the individual is motivated to comply with will approve or disapprove of the decision to become an entrepreneur. It is the perception about the extent to which other people who are important to them think they should or should not perform particular behaviors.

Despite the plethora of research outputs on the theory of planned behavior, the effect of subjective norm on intention is still elusive and unclear. Its effect has been the subject of more debate than the other constructs. As noted in the literature (*Literature Review, Chapter3*), some researchers came up with a significant positive effect of social norms on intention while others found inconclusive results.

Various scaled measures had been also used to measure subjective norm in previous studies. Kolvereid (1996) measured this factor using “beliefs x motives to comply”. Each normative belief about an important other is multiplied by the person’s motivation to comply with that important other and the products are summed across all of the person’s important others to result in a general measure that predicts subjective norms. In his measure he included three belief and three motives to comply items.

As cited in Tung (2011), the former group of items included “I believe that my closest family/closest friends/people who are important to me thinks that I should not (point 1)/ should (point 7) pursue a career as self-employed.” The latter group of items was: “To which extent do you care about what your closest family/closest friends/people who are important to you think when you are to decide

whether or not to pursue a career as self-employed?” The responses were given along a 7-point scale ranging from 1=I don’t care at all to 7= I care very much. The belief items multiplied with the respective motivation items and then the scores added together to generate an overall measure of subjective norm.

But recent studies are critical of “subjective norm x motives to comply” approach measure of subjective norm. It lacks predictive power compared with multiple-item measures. For instance, in a meta-analytic review on theory of planned behavior, Armitage and Conner (2001) argued that measure of multiple-item subjective norm have significantly stronger predictive power to intention than the measure of “subjective norm x motives to comply” or single-item measure of this factor.

This measure has also become more popular in entrepreneurship research. For example, Autio et al. (2001) measured the concept of subjective norm using four items to reflect the degree to which the individual perceived the university environment to encourage entrepreneurship, and the degree to which entrepreneurship was perceived as an acceptable career alternative after graduation. Similarly, Carr and Sequeira (2007) used an 8 item 5-point Likert scale to measure the participants’ response on the feelings of significant referents (siblings, close relatives, etc.) about owning a business. The scales range from 1=extremely negative to 5=extremely positive.

“1. My parent(s) feel \_\_\_\_\_ about my starting a business. 2. My spouse/significant other feels \_\_\_\_\_ about my starting a business. 3. My brother/sister feels \_\_\_\_\_ about my starting a business. 4. In general my relatives feel \_\_\_\_\_ about my starting a business. 5. My neighbor feels \_\_\_\_\_ about my starting a business. 6. My co-worker(s) feels \_\_\_\_\_ about my starting a business. 7. In general my acquaintances feel \_\_\_\_\_ about my starting a business. 8. My close friends feel \_\_\_\_\_ about my starting a business”.

Liñán et al (2005) also used multiple-time measure of subject norm in their study. They employed 11 items in 3 groups that reflect the opinion of significant others such as family, friends, colleagues and mates, about engaging in entrepreneurial behaviors.

Consistent with extant literature, we adapted the 3 item 7-point Likert scale measure (multiple-item measure) of subjective norm that Liñán (2008) had employed in measuring subjective norm. The items are

S1: My close family would approve of my decision to start a business

S2: My close friends would approve of my decision to start a business

S3: My friends from university would approve of my decision to start a business

## **Perceived Behavioral Control**

The last dimension of the theory of planned behavior, perceived behavioral control, is defined as the perception of the ease or difficulty of becoming an entrepreneur.

Many studies (Chen et al., 1998; Zhao et al., 2005; Kolvereid & Isaksen, 2006) have related the measures of perceived behavioral control to the concept of self-efficacy and perceived controllability of entrepreneurial behavior. And it has usually been surrogated by self-efficacy measures.

Chen et al. (1998) measured self-efficacy in reference to 26 roles and tasks related to entrepreneurship. Respondents were asked to indicate their degree of certainty in performing each of the roles/tasks on a 5-point scale ranging from 1= completely unsure to 5= completely sure. The 26-items were labeled as five specific self-efficacies through factor analysis. The five factors were marketing, innovation, management, risk-taking, and financial control. The study found significant relationship between self-efficacy and intention.

Similarly, Kolvereid and Isaksen (2006) used an 18-item pure self-efficacy scale to measure and capture the degree of confidence of respondents regarding accomplishing different tasks successfully on an 11-point scale ranging from 0= no confidence at all to 10= complete confidence. These items were subsequently labeled as four specific self-efficacy components through factor analysis, such as opportunity recognition, investor relationships, risk-taking and economic management. However, the results of their study did not support the influence of perceived behavioral control on entrepreneurial intention.

Kolvreid (1996) measured perceived behavioral control in terms of six general items. The author found that perceived behavioral control was significantly influencing entrepreneurial intention.

As the overview shows, a person's control over an entrepreneurial behavior included the capability and controllability to form a venture. Therefore, in this study, the questions to measure perceived behavioral control of the students include the perception of both self-capability and controllability. For the fact that it is holistic and paralleled with previous multiple item measures, we employed the six items measure that Linan & Chen (2009) used to measure perceived behavioral control. The respondent students were asked to indicate their level of agreement with the statements about their feeling of capability and controllability regarding creating own business. The six items are:

P1: Starting a firm and keeping it working would be easy for me

P2: I am prepared to start a viable firm

P3: I can control the creation process of a new firm

P4: I know all the necessary practical details to start a firm

P5: I know how to develop an entrepreneurial project

P6: If I tried to start a firm, I would have a high probability of succeeding

### 3.2.3.2 The Dependent Construct

#### **Entrepreneurial Intention**

As stated in the literature part of this dissertation intention is the best predictor of entrepreneurial behavior as starting a new company is typically a planned behavior. It is used as the dependent variable in many entrepreneurship behavioral studies detailed in the literature (*Literature Review, Chapter3*). Researchers (Autio et al., 2001; Chen et al., 1998; Hood & Young, 1993; Kolvereid & Isaksen, 2006; Krueger and Carsrud, 1993; Zhao et al., 2005) apparently agreed on measuring intention in terms of the likelihood that one will engage in entrepreneurship at some time in the future. Within that process, it is clear that both single and multiple-item measures have frequently been employed to measure intention to a specific behavior.

Krueger (1993) measured this construct using a single-item with dichotomous scale (yes or no): “Do you think you’ll never start a business?” Easy to use though, Cooper & Schindler (2008) questions the robustness of this measure. They claimed that it was a loose measurement to provide sufficient information.

Differently, Kolvereid (1996) measured entrepreneurial intention using multiple item-scales to examine the choice between organizational employment and self-employment: “(1) If you were to choose between running your own business and being employed by someone, what would you prefer? (1=would prefer to be employed by someone; 7=would prefer to be self-employed); (2) How likely is it that you will pursue a career as self-employed? (unlikely-likely); and (3) How likely is it that you will pursue a career as employed in an organization? (likely -unlikely).”

The average score on the items represented the intentions to be self-employed, that is responses to the four questions were added together and the total score divided by four to get the intention to be self-employed.

Different from the “choice measure” of Kolvereid (1996), researchers tended to use general measure for entrepreneurial intention (Autio et al., 2001; Chen et al., 1998; Kolvereid & Isaksen,

2006; Zhao et al., 2005). For example, Kolvereid & Isaksen (2006) used a single item to measure intention to become self-employed: “How likely are you to be working full-time for the new business in one year from now? (seven-point scale from 1=very unlikely to 7=very likely).” In more detail, Autio et al. (2001) assessed entrepreneurial intention through examining the perceived likelihood of the individual to start a new firm (on part-time or full-time) within one or five years: “Start a firm on full-time basis within one year or five years from now; starting a firm on part-time basis within one year or five years.” A 5-point scale was used, ranging from 1 indicating not at all likely to 5 indicating already stated a firm. However, in the context of our study, the participants (engineering students on campus) may lack a clear concept about the difference between intentions toward part-time and full-time entrepreneurship. In this sense, a combined way to measure the general entrepreneurial intention is more appropriate.

Without distinguishing part-time or full-time engagement in entrepreneurship, some researchers measured entrepreneurial intention in a more general way. Chen et al. (1998) measured entrepreneurial intention in terms of 5 items: (1) how interested the respondents were in setting up their own businesses; (2) to what extent they had considered setting up their own business; (3) to what extent they had been preparing to set up their own business; (4) how likely it was that they were going to try hard to set up their own business; and (5) how soon they were likely to set up their own business. Their study aimed to test the effect self-efficacy on entrepreneurial intention. As the sample included MBA students, business owners and executives, the intention measurement emphasized more on the detailed planning of creating own business.

Similarly, Zhao et al. (2005) investigated the effect of self-efficacy on MBA students’ intention to become entrepreneur. The authors measured entrepreneurial intention in terms of how interested the respondents were in engaging in prototypical activities (starting a business, acquiring a small business, starting and building a high growth business, and acquiring and building a company into a high-growth business) in the next 5 to 10 years. A 5-point Likert scale was used, ranging from 1 (very little) to 5 (a great deal). This measure of entrepreneurial intention tended to access the intention toward specific forms of startup, rather than the general intention to create a new venture. In this dissertation, the participants are engineering students on campus and the entrepreneurship education is awareness education which aims to deliver entrepreneurial knowledge and skills to students in order to improve their attitudes and intentions toward entrepreneurship. The items to

measure the entrepreneurial intention of the students is more appropriate to be general and related to the university environment (e.g., entrepreneurial activities/programs offered in university).

Accordingly, we employed the intention measures that Liñán and Chen (2009) used to measure students' intentions toward entrepreneurship. The measures actually show the chance that students in the entrepreneurship education course would like to form a venture in the future.

The items include:

I1: I am ready to do anything to be an entrepreneur

I2: My professional goal is becoming an entrepreneur

I3: I will make every effort to start and run my own firm

I4: I am determined to create a firm in the future

I5: I have very seriously thought of starting a firm

I6: I have the firm intention to start a firm some day

### 3.2.3.3. Control Variables

Control variables assess the exogenous influences on the dependent variable. Demographic variables are oftentimes used to control for a possible effect on the dependent variable (Lorz, 2011). We collected demographic information at the beginning of the survey including students' gender, age and startup experience, parents' education level, employment status, and family income.

**Gender:** Among other socio-economic factors, respondents were asked to state their gender. The variable was coded as a dummy variable (0; 1), with "0" denoting female and "1" denoting male.

**Start-up experience:** Respondent students also stated the experience they had in startups. The variable was coded as a dummy variable (0, 1), with "0" denoting no and "1" denoting yes.

**Self-employment experience:** students were asked if they had personally founded a venture in the past and the answers were coded as a dummy variable (0, 1), with "0" denoting no venture experience and "1" an existing venture experience.

**Start-up valuation:** Respondent students also expressed their feeling about working in start-ups. The variable was coded as a dummy variable (0, 1), with "0" denoting negative and "1" denoting positive experience.

**Mothers' and fathers' level of education:** As parts of socio economic variables, students were requested to state their fathers' and mothers' level of education. The answers were coded as a categorical variable with "1" denoting primary, "2" secondary and "3" university or tertiary level.



Parents' Occupation: This was a dummy variable included in the questionnaire to ask about the self-employment experiences of students' parents. The answers were coded as "0" denoting no and "1" denoting yes.

Family income: students were also asked to state their family income status. The variable was categorical variable ranged from "3" denoting high income group, "2" denoting middle income group and "1" low income groups.

#### 3.2.4. Data Collection Procedure

Basing on the measures of the theory of planned behavior, we collected data in a survey with fourth year engineering students at Debre Berhan University.

Using data from one university has many empirical backings (Oosterbeek et al. 2010; von Graevenitz et al. 2010; Lerner and Malmendier 2011). It provides a more controlled setting and reduces potential confounding effects due to unobserved heterogeneity.

We handed out printed questionnaires to the respondents in class with prior permission from the instructor. Then, we reminded the students that honesty for self-assessment was very important for a reliable and accurate data. We also assured the students about anonymity and confidentiality of their responses. Further, we told them that there were no right or wrong answers for each of the questions and the survey was not supposed to evaluate their performance and had nothing to do with their grade. The participants were strongly encouraged to answer the questions carefully based on their true feelings. We also informed the students that the reliability and validity of the completed questionnaires would be checked and individual score would be compared with the general score of the total sample, and the improper ones would be screened out.

These procedures should reduce the participants' evaluation apprehension and make them less likely to edit their answers to the questions to be more socially desirable or acquiescent, and thus reduce response error and common method variance (Podsakoff, et al., 2003).

A random sampling technique was employed to select the respondents from both the entrepreneurship group and control group students. It is recognized as an appropriate method to get a representative and unbiased sample (MacMillan & Katz, 1992).

Students in experimental group or entrepreneurship group were enrolled in a mandatory entrepreneurship course offered in civil and construction engineering departments at Debre Berhan University. They were in their fourth year (of their five year program) of study when they joined

the survey. The students were surveyed at two time points, at the beginning (September 2013) and end of the entrepreneurship education program (December 2013). A total of 150 students were selected for the survey.

Students in the control group were fourth year mechanical and electrical engineering students in the same university. The students were not exposed to entrepreneurship course at the time of the survey. Totally 120 control group students were selected.

The time we collected the data from students in the control group was similar to the one for students in the entrepreneurship group. It ranged from September 2013 to December 2013.

The questionnaire was anonymous but was coded in order to match the pre-course and post-course questionnaires. We received all the questionnaires dispatched to the students.

Analysis of the data ensured that students in the control group revealed no significant differences from students in the entrepreneurship group at pre-test in their background characteristics such as age, gender, start-up experience, parents' self-employment experience, level of studies and family income.

The same is true in their perceptions to entrepreneurship. They unveiled no substantial differences in the constructs of entrepreneurial intention and intention per se prior to the course (section 3.3).

The only visible difference between the entrepreneurship group and the control group was that students in the control group did not participate in the course that the entrepreneurship group students attended.

### 3.2.5. Data Analysis Procedure

For a credible and valid statistical conclusion, examining the data prior to analysis is an inevitable step to go through. As such we conducted some pre-analysis tests to ensure the appropriateness of the data collected through paper and pencil close ended questionnaire.

First, we examined the dataset for non-response bias. Then we tested the data for normal distribution and multi-collinearity. Reliability and validity of the measurements used in the survey were then tested and common method variance was discussed (figure14).

In this sense, we computed the descriptive information of the variables of the conceptual model before we proceeded to ANOVA and T-test that were employed to characterize the impact of demographic factors on entrepreneurial orientation of the students. Finally, the entrepreneurial intention model was analyzed with structural equation model (SEM) path analysis and difference-in-difference (DD) method.

The next section discusses each issue subsequently.

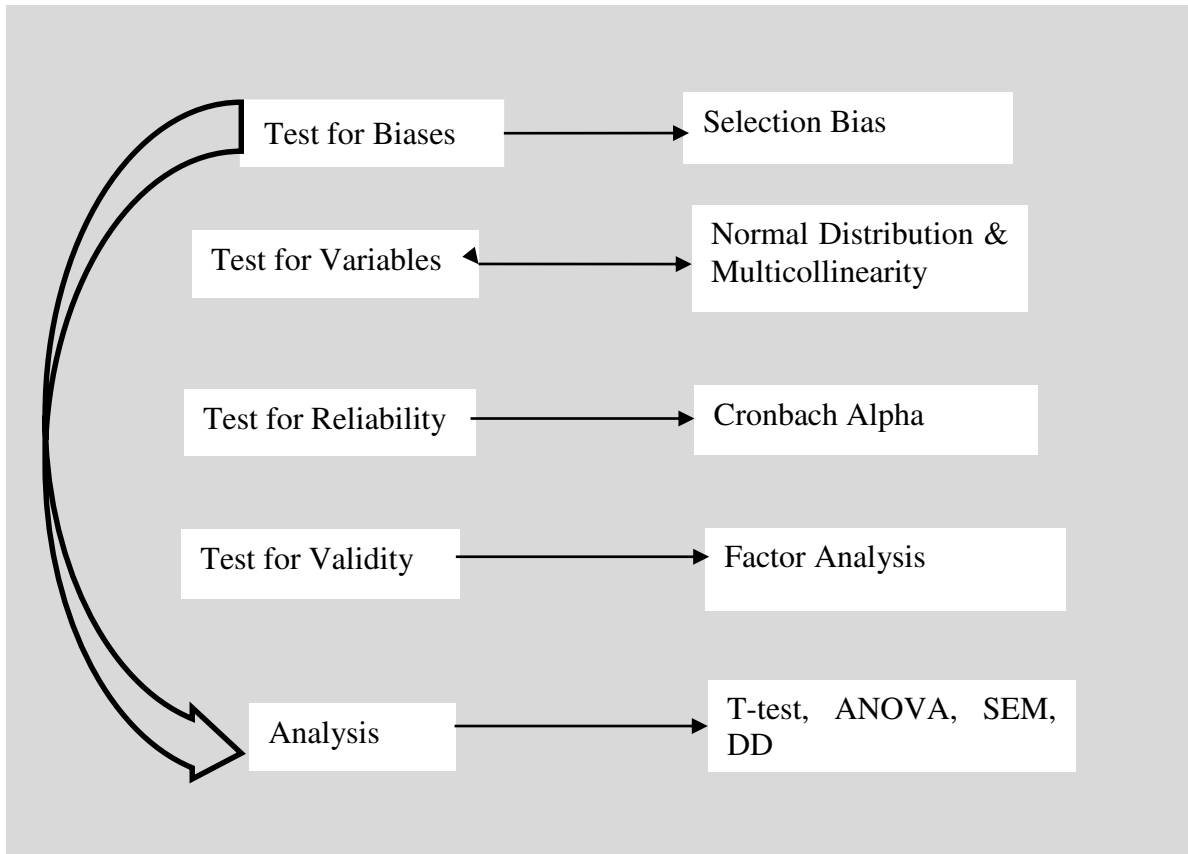

Figure 14 Data Analysis Procedure  
Source: Adapted from Atanasova (2007:115)

### 3.2.6. Pre-analysis Test

#### 3.2.6.1. Check for Biases

We selected the samples from 4<sup>th</sup> year engineering students at Debre Berhan University. We employed random sampling to reduce sample selection bias from participation of students who already had higher predisposition toward entrepreneurship against control group students. In fact, enrollment in the course was mandatory and this would possibly reduce self-selection bias from purposeful enrollment of students.

We conducted independent sample t-tests for probable differences between the entrepreneurship and control groups in the mean scores of attitude toward entrepreneurship, subjective norm, perceived behavioral control and entrepreneurial intention (Table 9).

Table 9 Tests for Selection Bias

Constructs	Entrepreneurship group		Control group		Leven's Variance test, F test	Equality of means, t-test
	No.	Mean	No.	Mean		
A <sub>t</sub>	150	3.95	120	3.85	0.7972	0.9656
S <sub>n</sub>	150	3.18	120	3.14	0.2171	0.3453
P <sub>b</sub>	150	2.56	120	2.52	0.9505	0.8274
I <sub>n</sub>	150	2.31	120	2.13	0.6019	0.0826

It turned out that differences between students in the entrepreneurship group and control group in their tendency toward entrepreneurship just prior to the course were indiscernible. They were not different with respect to their scores on (A<sub>t</sub>), subjective norms (S<sub>n</sub>), perceived behavioral control (P<sub>b</sub>) and entrepreneurial intention (I<sub>n</sub>). The t-test values for equality of means felt short of the recommended value of 1.96 to accept mean differences between the two groups (P>0.05).

In addition, the Levene's test suggested that variances for the two groups were equal, satisfying the assumption of homogeneity of variance. Hence, selection bias was not a concern in our study.

### 3.2.6.2. Tests of Variables

The data collected for our study were tested through data screening. For that, we conducted two tests. First, variables were checked for normal distribution. Second, we tested for multicollinearity of independent variables.

In order to test for normal distribution, the variables of the key constructs were tested for skewness and kurtosis. Incorrect estimation of skewness and kurtosis of the data can cause wrong estimation of the variance (Tabachnick and Fidell, 2007, p.81).

Skewness tells us the direction of variation of the dataset. It indicates the symmetry of the distribution; a value of 0 represents a perfect normal distribution. Bernard (2000: 522) contended that getting a perfect normal distribution from real data is next to none and what matters is just the size. Values from -2 to +2 are deemed acceptable for parametric tests and assume a normal distribution. A negative value indicates that the tail of the distribution is more stretched on the side below the mean whereas a positive value indicates the distribution is more stretched on the side above the mean.

On the other hand, kurtosis measures the flatness (negative values) or peakedness (positive values) of a random variable distribution and it lies in the range of -2 to +2, acceptable for parametric tests.

Table 10 Tests for Normal Distribution

Variables	At <sub>0</sub>	At <sub>1</sub>	S <sub>0</sub>	S <sub>1</sub>	Pb <sub>0</sub>	Pb <sub>1</sub>	In <sub>0</sub>	In <sub>1</sub>
Skewness	0.6934	0.1352	0.6376	0.3081	0.5768	0.9163	0.9215	0.6182
Kurtosis	0.0530	0.0245	0.0685	0.0421	0.0183	0.0441	0.0362	0.0253
Prob >chi2	0.1326	0.2527	0.3021	0.0935	0.1263	0.1621	0.5372	0.4351

*The subscripts 0 and 1 indicates the beginning and end of the course.*

For our data, as depicted in table10, the distribution for all the constructs in both periods was normal. The value for skewness varied between 0 and 0.9724 while for kurtosis it ranged from 0 to 0.07. The values for both measures were found in the recommended range to witness normality of the distribution for the constructs.

When we come to the concept of multicollinearity, it measures the size of linearity among predictors. The existence of a perfect linear relationship among predictors makes it hard to uniquely determine the estimates for a regression model. The independent variables become linearly related. Hence, before regressing independent variables on the dependent variable, the collinearity of the independent variables should be examined.

We used Stata12 diagnostic tools to identify the existence of collinearity problem in our dataset. It provides some measures of collinearity such as tolerance, variance inflated factor (VIF) and the Durbin-Watson test. In this dissertation we used the two commonly used measures of collinearity such as tolerance and variance inflated factor.

The first, tolerance, measures the correlation between the independent variables and varies between 0 and 1, with 0 being an indication of a very strong collinearity between the examined independent variables. That is, Collinearity is indicated if the tolerance value is “very low” (Brace, Kemp, & Snelgar, 2004).

Variance Inflation Factor (VIF) is an alternative indicator of collinearity, where large values indicate a strong relationship between independent variables. It measures how much the variance of an estimated regression coefficient increases if the explanatory variables are correlated. As a rule of thumb, if any of the VIF values exceeds 5 or 10, it implies that the associated regression coefficients are poorly estimated because of multicollinearity (Montgomery, 2001).

Table 11 Test for Multicollinearity

Variables	At	Sn	Pb	Steva	Fedu	Medu	Fsel	Msel	SelfE	Gend	Age	Inc
VIF	4.00	3.89	2.06	3.97	2.05	2.48	2.18	2.11	2.17	1.47	1.24	1.20
1/VIF	0.25	0.26	0.49	0.25	0.49	0.40	0.46	0.48	0.46	0.68	0.81	0.83
Mean VIF= 2.40												

As displayed in table11, both the tolerance and VIF statistics evinced that multicollinearity was not a problem. We found that the VIF value was 2.40, which is quite less than the minimum threshold value to evidencing multicollinearity. By the same vein, the tolerance value is much higher than the threshold value to witness multicollinearity.

Under this step of data analysis procedure, we also verified the demographic homogeneity between the entrepreneurship and control groups. It aims to test if the two groups had the same demographic characteristics (students' age, gender, start-up experience, parent's self-employment experience, parent's education level and parents' income level) (table 12).

Table 12 Demographic Differences between the Entrepreneurship and Control Group

Var	Age	Gender	Fself	Mself	Feduc	Meduc	Income	Staexp	Staeva	SelfE
Value	0.08	0.07	0.02	0.017	0.04	0.01	0.04	0.01	0.02	0.01
Df	268	268	268	268	268	268	268	268	268	268
Sig.	0.13	0.16	0.46	0.39	0.58	0.90	0.49	0.88	0.88	0.61

As can be learned from the table, there was no significant difference between students in the entrepreneurship and control group. Alike the constructs of perception to entrepreneurship variables, the systematic difference between the two groups was insignificant even at 10% level of significance. Thus, both sub-samples were considerably homogeneous.

Hence, we understood that the control group students were plausibly appropriate for the comparison study with the entrepreneurship group students in order to test the effectiveness of the entrepreneurship course.

### 3.2.6.3. Validation of the Measurement Scale

When constructing scales, it is normal to ask the reliability of the scale. For a sound and accurate assessment, consistency and unbiasedness should prevail in it. Valid and reliable survey measurement is at the heart of an accurate research finding. We tested the reliability and validity of the measurement scales we used for both groups of students before we proceeded to further analysis of our data.

The reliability analysis of a measure (a questionnaire) represents the extent to which it is consistent overtime. It indicates the stability or replicability of the instrument used to measure the constructs. With the same experiment and instrument, other researchers should uphold the previous result. Consistent with Nunnally (1978) any significant result must be more than a one-off finding.

Correspondingly, for a reliable measure, a researcher should get the same score when he used it on a separate occasion (test-retest reliability), or two people who are the same in terms of the construct being measured should get the same score (Field and Miles, 2010). That is, individual items (set of items) should produce results consistent with the overall questionnaire.

Field (2005) suggested that the simplest and practical way to do this is to use split half reliability. The idea is that after the dataset is split in to two, a score for each participant is calculated based on each half of the scale. Hence, if the scale is reliable, a person's score on one half of the scale should be the same as /or similar to their score on the other half: therefore, across several participants scores from the two halves of the questionnaire should correlate perfectly.

The correlation between the two halves is the statistic computed in the split half method, with large correlations being a sign of reliability (Field, 2005). The existence of several ways in which a set of data can be split is however critical of this method. The results of these model are strongly influenced by the way we split the scale and it is less reliable if the number of items in the two halves are not equal. That is the reliability estimate obtained using any random split of the items is likely to differ from that obtained using another.

To overcome this problem, Cronbach (1951) came up with a measure that is loosely equivalent to splitting the data in to two in every possible way and computing the correlation coefficient for each split. The average of these values is equivalent to Cronbach's alpha ( $\alpha$ ), which is the most common measure of scale reliability (Flynn et al., 1994; Nunnally, 1978; Field, 2005).

Mathematically, it is defined as

$$\alpha = \frac{K}{K - 1} \left( 1 - \frac{\sum_{i=1}^k \delta^2 Y_i}{\delta^2_x} \right)$$

Where K represents components or items  $\delta^2_x$  is the variance of the observed total test scores,  $\delta^2 Y_i$  the variance of component i for the current sample of persons,  $X = Y_1 + Y_2 + \dots + Y_K$  (Develles RF, 1991).

The values for reliability coefficients range from 0 to 1.0 where a coefficient of 0 means no reliability and 1.0 indicates perfect reliability. As perfection is by no means possible, oftentimes reliability is less than 1.0.

Generally, if the reliability of a standardized test is above 0.80, it is said to have very good (Vegada, et al, 2014). Kline (1999) on the other hand contended that although the generally accepted value

of 0.8 is appropriate for cognitive tests such as intelligence tests, a cut-off 0.7 is more suitable. He goes on saying that when dealing with psychological constructs values even below 0.7 can, realistically, be expected because of the diversity of the constructs being measured. Consistent with that Hair et al (2010) suggested that scales are deemed internally consistent if the Cronbach  $\alpha$  is above 0.6.

To this end, as rule of thumb, George et al (2003) suggested that tests with reliability coefficient 0.90 and above as excellent reliability, those between 0.80-0.90 good, those between 0.70-0.80 as acceptable, those between 0.60-0.70 as questionable and therefore needs to be supplemented by other measures to determine scales, those between 0.50-0.60 as poor and needs revision of test and those below 0.5 as an unacceptable.

At this point, researchers like Streiner, D.L. (2003) contended that high reliability values need to be taken carefully. He said that a very high value (0.95 or higher) is not necessarily desirable, as this indicates that the items may be entirely redundant. He stressed that even if scores on similar items should have to be related or internally consistent; their presence is meaningless if each scale doesn't contribute some unique information for the variable that it explains.

As our study also deals with psychological constructs, the calculation of the reliability coefficient or alpha was framed consistent with the rule of thumb values suggested above.

In doing so, first we constructed an inter-item correlation (item-rest correlation) matrix for each scale (Appendix3). It helps to identify the item that is inconsistent with the averaged behavior of others. If any item is found inconsistent with the averaged behavior of others, the item can thus be discarded.

The analysis is performed to clean the measure by eliminating unnecessary or “garbage” items before determining the factors that represent the construct (Churchill, 1979). In a reliable measure, all items should correlate well with the average of the others.

A small-item correlation shows that the item is not measuring the same construct the other items in the study measure. As a rule of thumb a correlation value less than 0.2 or 0.3 indicates that the corresponding item does not correlate well with the over all, and thus, it may be dropped. (Everitt, 2002; Field, 2005; Hair et al., 2006).

For our dataset, all the items had a significant correlation with the other items. Observation of the correlation table indicated that the correlation values for all the items with others is greater than 0.65 (Appendix 3).



In light of this, we proceeded with the calculation of Cronbach's alpha with all the items in the questionnaire. The results showed that the Cronbach's alpha for all the values is high enough to warrant reliability (Table13).

All the variables such as attitude toward entrepreneurship, subjective norm, perceived behavioral control, intention to entrepreneurship and their constituents scored high values of Cronbach's alpha for all the entrepreneurial group, control group and combined group ( Cronbach alpha > 0.8086).

To this end, the measurements used in this study were reliable for both groups of students. It also implies that the participants for the survey managed to understand the wordings of the questions. Hence, we can assume internally consistent scales for our analysis; and we can proceed with establishing the validity of the scales.

Table 13 Tests for Reliability

<b>Constructs and items</b>	<b>Cronbach <math>\alpha</math> Control Group</b>	<b>Cronbach <math>\alpha</math> Entrepreneurship Group</b>	<b>Cronbach <math>\alpha</math> Whole Sample</b>
<b>1. Attitude Toward the Behavior</b>	<b>0.9236</b>	<b>0.9212</b>	<b>0.9245</b>
a. Being an entrepreneur implies more advantages than disadvantages to me	0.9214	0.9230	0.9250
b. A career as entrepreneur is attractive for me	0.9094	0.9030	0.9073
c. If I had the opportunity and resources, I would like to start a business	0.8912	0.8944	0.8950
d. Being an entrepreneur would entail great satisfactions for me	0.8997	0.8930	0.8985
e. Among various options, I would rather be an entrepreneur	0.9061	0.8990	0.9075
<b>2. Social Norms</b>	<b>0.8830</b>	<b>0.9025</b>	<b>0.8935</b>
a. Your close family	0.8086	0.8584	0.8365
b. Your close friends	0.8359	0.8661	0.8517
c. Your close friends from university	0.8556	0.8577	0.8566
<b>3. Perceived Behavioral Control</b>	<b>0.8974</b>	<b>0.8884</b>	<b>0.8929</b>
a. To start a firm and keep it working would be easy for me	0.9276	0.9450	0.9365
b. I am prepared to start a viable firm	0.8732	0.8515	0.8627
c. I can control the creation process of a new firm	0.8596	0.8439	0.8519
d. I know the necessary practical details to start a firm	0.8693	0.8558	0.8630

e. I know how to develop an entrepreneurial project	0.8693	0.8539	0.8617
f. If I tried to start a firm, I would have a high probability of succeeding	0.8799	0.8546	0.8678
<b>4. Entrepreneurial Intention</b>	<b>0.9282</b>	<b>0.9126</b>	<b>0.9205</b>
a. I am ready to do anything to be an entrepreneur	0.9404	0.9251	0.9330
b. My professional goal is becoming an entrepreneur	0.9130	0.8977	0.9056
c. I will make every effort to start and run my own firm	0.9049	0.8846	0.8948
d. I am determined to create a firm in the future	0.9056	0.8830	0.8946
e. I have very seriously thought of starting a firm	0.9142	0.8937	0.9039
f. I have the firm intention to start a firm some day	0.9066	0.8921	0.8992

#### Tests of Validity

After confirming the reliability of the measurement instrument, we then advanced to conducting the validity of the survey.

It refers to how well the instrument measures the constructs what it sets out to measure (Litwin, 1995: 33). A valid instrument exactly measures what we think we are measuring. It indicates whether “there is a close fit between the construct it supposedly measures and actual observations made with the instrument” (Bernard, 2000: 50).

For the fact that our instrument consists of multiple questions that measure different constructs, factor analysis is deemed an appropriate method to assess its construct validity (Nunnally and Bernstein, 1994).

This method has got many empirical backings from different perspectives: developing an instrument for the evaluation of school principals (Lovett, Zeiss, & Heinemann, 2002), assessing motivation of high school students (Morris, 2001), and determining service types to be offered to college students (Majors& Sedlacek, 2001), evaluating construct validity of the brief pain investment (Thomas, 2010), assessing the impact of entrepreneurship education on entrepreneurial intention (Urban, 2009).

In calculating validity of our instrument, we followed the “Guttman” (1954) or “K1” rule that is commonly known as Kaiser Criterion or root criterion or eigenvalue-one criterion. It states that to

ensure factor validity of an instrument retain any factor or component that has an eigenvalue greater than 1.

Using this criterion, four eigenvalues greater than 1 emerged out of the data we collected for the analysis. Hence, a four-factor solution was incorporated (Table 14).

We also employed the Kaiser-Meyer-Olkin (KMO) measure of sampling adequacy to strengthen the validity of eigenvalue criteria.

The KMO measure takes values between 0 and 1, with small values indicating overall the variables have too little in common to warrant a factor analysis and the vice versa. According to Kaiser (1974) a value 0.00 to 0.49 is unacceptable, 0.50 to 0.59 is miserable, 0.60 to 0.69 is mediocre, 0.70 to 0.79 is middling, 0.80 to 0.89 is meritorious and 0.90 to 1.00 is regarded as marvelous.

Our variables, in light of the above, had much in common to affirm factor analysis. The overall KMO value for the scores was 0.8849. And also, none of the KMOs were so small to warrant exclusion or reduction of any factor.

Table 14 Factor Loadings of the Theory of Planned Behavior

Item	In	Pb	At	Sn	KMO
A1: Being an entrepreneur implies more advantages than disadvantages to me			0.8295		0.9068
A2: A career as entrepreneur is attractive for me			0.9207		0.8611
A3: If I had the opportunity and resources, I would like to start a business			0.9747		0.8564
A4: Being an entrepreneur would entail great satisfactions for me			0.9535		0.7970
A5: Among various options, I would rather be an entrepreneur			0.9231		0.8490
S1: Your close family				0.8313	0.9211
S2: Your close friends				0.7145	0.9033
S3: Your close friends from university				0.7240	0.8926
P1: To start a firm and keep it working would be easy for me		0.7799			0.9097
P2: I am prepared to start a viable firm		0.6288			0.8606
P3: I can control the creation process of a new firm		0.6547			0.8731
P4: I know the necessary practical details to start a firm		0.8665			0.9119
P5: I know how to develop an entrepreneurial project		0.9049			0.9168
P6: If I tried to start a firm, I would have a high probability of succeeding		0.9495			0.8270
I: I am ready to do anything to be an entrepreneur	0.9505				0.8356
I2: My professional goal is becoming an entrepreneur	0.6073				0.9453

I3: I will make every effort to start and run my own firm	0.7735				0.8817
I4: I am determined to create a firm in the future	0.8124				0.9050
I5: I have very seriously thought of starting a firm	0.8644				0.9195
I6: I have the firm intention to start a firm some day	0.9003				0.8755
Over all KMO					0.8849
Total (eigen values)					17.174
% of variance	31	20	23.02	19.80	93.82

The results thus indicated that all the variables should be included in the analysis of the data and the scales were independent. In addition, it turned out that the factor analysis, as expected, produced four components, such as attitude towards entrepreneurship, subjective norms, perceived behavioral control and intention to entrepreneurship.

#### Common Variance Test

The common variance test strengthens the results of the credibility of the measurement scale we found using reliability and validity tests.

The essence of common method variance is that, for the measurement method used to collect data, the correlation among variables might be spurious and creates false internal consistency. This in turn biases the estimates of the true relationship among the theoretical constructs. The problem soars when both the dependent and explanatory variables are perceptual measures derived from the same respondent (Podsakoff & Organ, 1986).

Hence, common method variance is variance attributed to the measurement method rather than to the constructs the measures represent (Podsakoff, MacKenzie, Lee, & Podsakoff, 2003: 879).

Self-report data can be one of the reasons for spurious correlations or false internal consistency if the respondents have a propensity to provide consistent answers to survey questions that are otherwise not related. Thus, common methods can cause systematic measurement errors that either inflate or deflate the observed relationships between constructs, generating both Type I and Type II errors (Chang et al, 2010).

Harman's single-factor test is one of the commonly used techniques for addressing the issue of common method variance (Chang et al, 2010; Carr & Sequeira, 2007; Harman, 1967). The basic premise of this technique is that if a substantial amount of common method variance is present, either a single factor will emerge from the factor analysis or one general factor will account for the majority of the covariance among the variables.

Following the procedure we used for validity analysis, we tested common method variance of the survey study with Harman's single-factor test. All the items of the constructs of the theory of planned behavior were loaded in to factor analysis.

The unrotated principal component factor analysis revealed the presence of four distinct factors with eigenvalue greater than 1.0 (table14). The four factors together accounted for 93.82 percent of the total variance. In addition, the first (largest) factor did not account for the majority of the variance. It accounted only for 31% of the variance. This confirms that no single item is accounted for the majority of the variance.

In regards, common method variance was not apparent in our data and it was not such a concern for our analysis and interpretation.

It is however a fact that data cleaning and confirming the appropriateness of the items and the scales are not and cannot in any way be end results. They are just the stepping stones for further analysis. In this sense, after we confirmed the quality and appropriateness of the data and scale, we advanced to test the statistical analysis of the hypotheses proposed in the conceptual framework.

### 3.3. Results and Discussion

This chapter objectively sets out to present the results of the data analysis used to test the hypotheses. It is a framing section that present and critically discuss the main findings of the dissertation.

It aims to discuss the following three points pertaining to entrepreneurial intention and its antecedents.

The first part is devoted to discussing the characteristics of the respondents and providing descriptive information on the dimensions of the theory of planned behavior for both entrepreneurship and control group students.

The second part essentially presents the results of a critical assessment of attitude toward entrepreneurship for both the entrepreneurship and control group students. It provides descriptive evidence about the effectiveness of the entrepreneurship course. In doing so, we fundamentally employed the t-test statistics.

This section also entails a deeper statistical analysis of the effects of demographic variables on the antecedents of intention and entrepreneurial intention. At this point we applied t-test and ANOVA. Nine demographic variables are reported in this part including age, gender, parent's self-

employment experience and income status, parent's education level, respondents' self-employment experience, and respondents' employment experience in start-ups.

Section three intends to explicate the effect of the entrepreneurship education course on students' attitude toward entrepreneurship. Thus, it reports the results of the hypotheses tests. In this process, first we checked the interrelationships among the constructs of the theory of planned behavior using SEM path analysis and then we applied a difference-in-difference framework to examine the effect of the course on entrepreneurial intention and its antecedents.

### 3.3.1. Descriptive Analysis of the Data

#### 3.3.1.1. Characteristics of the Participants

Table 3.7 summarizes the backgrounds of the students in the survey. We collected responses from fourth year engineering students at Debre Berhan University.

It turned out that the sample contained comparable number of male and female students. The proportion of male and female students in the sample was nearly the same. Out of 270 respondents, 138 (51.1%) were male while 132 (48.90%) were female students.

It was also considered that students in the survey were found in the same age category (table 15). The average age of the students was 23.06 years old, with the minimum age 21 and the maximum age limit 26 years old. A separate analysis of the two groups also indicated that the age difference between them appeared indiscernible. The average age of the students in the control group was 23.14 years while it was 22.98 years for the entrepreneurial group ( $p > 0.1$ ).

In addition, all the students in the survey responded that they had never attended any entrepreneurship course prior to the survey. But 34 students or 12.5% portrayed that they already had some start-up experience or were employed in startups sometime in the past. This included 12.24% students in the entrepreneurship group and 12.75% of students in the control group. Notwithstanding the startup experience, the overwhelming majority of them failed to have a positive evaluation of it. Only 24% of them felt positive about their startup experience. This was equivalent to 23.08% of the students in the entrepreneurship group and 25% of students in the control group.

Few students also reported that they engaged in self-employment activities before the survey. This was equivalent to 18 students (6.5%) with 11(7.14%) students in the entrepreneurship group and 7(5.88%) students in the control group.

It also came out that 9 students or 3.25 percent said their parents were self-employed. More specifically, 1.25% of control group students and 2 % of entrepreneurship students had parents that were self-employed. 5.76% of the students responded that their fathers were self-employed (6.63% for the entrepreneurship group and 4.93% for the control group students). At the same time, 3.76% of the students replied that their mothers were self-employed (4.59% for the entrepreneurship students and 2.96 % for the control group students).

Regarding the socio economic status of the students, 135 of them (50%) were from low income groups with 73(48.98%) and 62(50.98%) respectively were students from the entrepreneurship and control groups. In addition, 126 students or 46.5% came from middle income group backgrounds with 69 (45.92%) entrepreneurial group students and 56 (47.06%) control group students. It also turned out that 10 or 3.7% students responded that they came from high income group background. This comprised of 8 or 5.1% students from the entrepreneurship group and 2 or 1.96% students from the control group.

Observation of parents' level of education showed that 153 students or 56.5% of the respondents said that their fathers' level of education was primary level. This comprises 83 students from the entrepreneurship group (55.10%) and 69 students from the control group (57.84%).

Furthermore, the results disclosed that 88 students or 32% had fathers with secondary level of education. This represented 36.73% or 55 students from the entrepreneurship group and 27.45% or 33 students from the control group. It was only 11.5% or 30 students that reported fathers' education level tertiary with 8.16% or 13 students from the entrepreneurship group and 13.28% or 17 students from the control group.

On the other hand, primary education epitomized the students' mothers' level of education. This corresponded to 63% or 170 students with 92 students from the entrepreneurship group (61.22%) and 78 students from the control group (64.71%). Once again, 30.5% or 82 students reported that their mothers' level of education was secondary with 33.67% or 51 students from the entrepreneurial group and 27.45 or 31 students from the control group. But it was only 6.5% or 18 students that demonstrated their mothers' level of education was tertiary. This was equivalent to 5.1% or 7 students from the entrepreneurial group and 7.84% or 11 students from the control group.

Table 15 Characteristics of Respondents

Characteristics		Entrepreneurship Group (150=55.55%)		Control Group (120=44.45%)		All participants		t-test
		No.	%	No.	%	No.	%	
Gender	Female	69	45.92	63	52.94	132	48.89	0.1610
	Male	81	54.08	57	47.06	138	51.1	
Average Age		150	22.98	120	23.14	270	23.06	
Parent's Occupation								
Father-self Employed	Yes	10	6.63	6	4.93	16	5.76	0.4586
	No	140	93.37	114	95.07	254	94.24	
Mother-self Employed	Yes	7	4.59	4	2.96	10	3.76	0.3863
	No	143	95.41	116	97.04	260	96.24	
Both self-employed		3	2	2	1.25	9	3.25	
Socio-economic Level	Low	73	48.98	62	50.98	135	50	0.4470
	Middle	69	45.92	56	47.06	126	46.50	
	High	8	5.1	2	1.96	10	3.5	
Father's Education	Primary	83	55.10	69	57.84	152	56.5	0.5834
	Secondary	55	36.73	33	27.45	88	32.00	
	Tertiary	13	8.16	17	14.71	30	11.50	
Mother's Education	Primary	92	61.22	78	64.71	170	63	0.9042
	Secondary	51	33.67	31	27.45	82	30.5	
	Tertiary	7	5.10	11	7.84	18	6.5	
Start-up experience	No	132	87.76	105	87.25	236	87.50	0.8802
	Yes	18	12.24	15	12.75	34	12.50	
Star exp. Evaluation	Positive	3	25	4	22	7	24	0.8768
	Negative	8	75	14	78	22	76	
Self-employed	No	139	92.86	113	94.12	252	93.5	0.6103
	Yes	11	7.14	7	5.88	18	6.5	
Course		0	0	0	0	0	0	

We also outlined the differences between the students in the entrepreneurial and control groups concerning their entrepreneurial orientation. In doing so, we used different descriptive statistical methods such as percentages, quartiles, t-test and logarithmic mean differences.

A detailed analysis of table16 revealed that prior to the course, the major portion of the students perceived that their entrepreneurship orientation was below average or below neutral point (less than 3 in the scale of 7) where they had unfavorable perception of entrepreneurship as a viable career option. It came out that 64% of students in the control group and 67% of students in the entrepreneurship group believed that their attitude towards entrepreneurship was below neutral point.

Similarly, 40% of students in the control group and 44% of students in the entrepreneurship group did not agree with the statement that important others influence their decision towards



entrepreneurship while 23% of students in the control group and 23% students in the entrepreneurship group are indifferent about the effect of close referents on entrepreneurial behavior.

The students also scored the same on perceived behavioral control. About 80% of students in the control group and 73% of students in the entrepreneurship group did not think they had the behavioral control toward entrepreneurship.

Intention toward entrepreneurship also followed suit. 89% of students in the control group and 90% of the students in the entrepreneurship group perceived that their intention to entrepreneurship was below average.

On the contrary, at the end of the course students in the entrepreneurship group showed significant changes in their entrepreneurial orientation. In fact, there are slight improvements in the perception to entrepreneurship for students in the control group as well. It came out that only 13.3% of students in the entrepreneurship group revealed that their attitude to entrepreneurship was not favorable. The corresponding value for students in the control group was 41.7%.

The same applied to subjective norms. 29.2% of students in the control group reported unfavorable perception of the importance close referents had on the decision to be an entrepreneur while only 10.7% of students in the entrepreneurship group perceived that close referents could affect their decision to be an entrepreneur.

58.3% of the students in the control group had an unfavorable perceived behavioral control towards entrepreneurship against 17.3% for the entrepreneurship students. The average intention towards entrepreneurship was below the neutral point or unfavorable for 70.6% of students in the control group compared to 10% of students in the entrepreneurship group.

Therefore, the descriptive analysis (the average values) of the constructs of the theory of planned behavior for students in the entrepreneurship group showed that they had favorable perceptions about entrepreneurial attitudes, subjective norms, behavioral control and intention proceeding the course. As indicated, the score for students in the control group were much lower than for students in the entrepreneurship group. This might indicate that engineering students who were not exposed to the entrepreneurship course had less favorable perceptions about entrepreneurship than students who were exposed to the course.

To further analyze and gain more profound insight about the entrepreneurial orientation of the two groups of students in the two periods, we also employed t-test and logarithmic changes (Tables 16 and 17).

Perusal of the tables indicated that the students had no visible differences in their entrepreneurial orientation prior to the course. The average values for attitude towards entrepreneurship, subjective norms, perceived behavioral control, and then intention to entrepreneurship for the two groups were not statistically different. The t-test results revealed that the differences between students in entrepreneurship and control groups regarding their antecedents of entrepreneurial behavior were not significant.

But at the end of the course, the students in the two groups exhibited significance differences in their average entrepreneurship orientations. Engineering students who had completed the entrepreneurship courses scored more in terms of their belief on attitude toward entrepreneurship, subjective norm, perceived behavioral control and entrepreneurial intention than those who were not exposed to the entrepreneurship course.

The logarithmic change on the constructs of the theory of planned behavior between the two periods also revealed a higher increment in the constructs of the theory of planned behavior for students in the entrepreneurship group than for the students in the control group. This confirms the tests we just did above. For instance, attitude towards entrepreneurship was increased by 54% for students in the entrepreneurship group versus 8.8% for students in control group. Similarly, subjective norm increased by 74% for students in the entrepreneurship group against 22.8% for students in the control group. Perceived behavioral control was increased by 84% for the entrepreneurship group while it was increased by 22% for the control group students. Consistently, entrepreneurship intention for the entrepreneurship group students increased by 92% against 20% for students in the control group.

In order to better understand the impact of entrepreneurial education on the different constructs, a further analysis was conducted. For that only data from the entrepreneurial group was taken with matched pairs at the beginning and end of the course (N=150). This was valuable to indicate the progress of students' entrepreneurial orientation over the period of course.

Observation of table19 revealed that the average entrepreneurial intention for students in the 1<sup>st</sup> quartile, 2<sup>nd</sup> quartile, 3<sup>rd</sup> quartile and 4<sup>th</sup> quartile before the course was 2.16, 2.3, 3, and 4.16 respectively. After the course, the average entrepreneurial intention became 6.13 for the first

quartile, 5.92 for the 2<sup>nd</sup> quartile, 5.94 for the 3<sup>rd</sup> quartile and 5.43 for the 4<sup>th</sup> quartile students in the entrepreneurship group.

The results ensure that the highest impact of the course was observed on students in the 1<sup>st</sup> and 2<sup>nd</sup> quartile. But for students who were in the 3<sup>rd</sup> and 4<sup>th</sup> quartile the change was tiny. That is, students who already had a higher proclivity to entrepreneurship prior to the course did not have a big room for improvement compared with students who had the lowest level of intention to entrepreneurship at the same time. It thus indicated that initial entrepreneurial intention has a big influence on the final level of entrepreneurial intention. It also appeared that students attending the course obtained a more realistic perspectives of what it takes to be an entrepreneur.

To this end, for entrepreneurship education to be more effective to unfolding the black box of the skills and abilities to start business and regard entrepreneurship as a desirable career option, entrepreneurial educators and policy makers need to identify the target group that fits each course objective (*Literature Review, Chapter3*). That is, when preparing entrepreneurship course material, a careful analysis of the target group has a consequential benefit to achieve its objective with the minimum resource. Hence, the course objectives should be different for students at different levels of the academic system such as elementary school vs high school vs university vs entrepreneurs. For instance, an awareness education course which was emblematic of Debre Berhan University could be more effective for students who did not touch up on entrepreneurship.

Table 16 Percentages of Students for the Constructs of Theory of Planned Behavior

Groups	Constructs	Below average		Average		Above average		Total
		No.	%	No.	%	No.	%	
Control at T <sub>0</sub>	At	77	64	8	7	35	29	120=100%
	Sn	48	40	28	23	44	37	
	Pb	96	80	6	5	18	15	
	In	107	89	1	1	12	10	
Control at T <sub>1</sub>	At	50	41.7	25	20.8	45	37.5	120=100%
	Sn	35	29.2	31	25.8	54	45	
	Pb	70	58.3	22	18.3	28	23.3	
	In	85	70.6	12	9.8	23	19.6	
Entrepreneurship at T <sub>0</sub>	At	101	67	12	8	37	25	150=100%
	Sn	66	44	35	23	49	33	
	Pb	110	73	15	10	25	17	
	In	135	90	2	1	13	9	
Entrepreneurship at T <sub>1</sub>	At	20	13.3	6	4	124	62.7	150=100%
	Sn	16	10.7	14	9.3	120	100	
	Pb	26	17.3	20	13.3	104	69.3	
	In	15	10	15	10	120	80	

Table 17 Constructs of Theory of Planned Behavior before and after the Course

Variables	Control group T <sub>0</sub>	Entrepreneurship group T <sub>0</sub>	Equality of means		Control T <sub>1</sub>		Entrepreneur T <sub>1</sub>		Equality of means	
			t	p	t	p	t	p		
At	3.04	2.97	0.7186	0.473	3.58	6.10	-25.9	0.0000		
Sn	3.14	3.18	-0.35	0.730	3.93	6.39	-29.5	0.0000		
Pb	2.52	2.57	-0.83	0.409	3.1	5.85	-73.0	0.0000		
In	2.32	2.31	0.93	0.083	2.79	5.65	-71.5	0.0000		

Table 18 Logarithmic Changes in the Constructs of Theory of Planned Behavior

	Group	Constructs			
		At	Sn	Pb	In
Log of the mean differences at T <sub>0</sub> and T <sub>1</sub>	Entrepreneurship	0.54	0.74	0.840	0.916
	Control	0.088	0.229	0.219	0.196

Table 19 Analysis of the Students Entrepreneurial Perception

Constructs	At <sub>0</sub>	At <sub>1</sub>	Sn <sub>0</sub>	Sn <sub>1</sub>	Pb <sub>0</sub>	Pb <sub>1</sub>	In <sub>0</sub>	In <sub>1</sub>
1 <sup>st</sup> quartile	2.40	6.20	2.66	6.3	2.17	6.03	2	6.13
2 <sup>nd</sup> quartile	2.60	6.21	3.0	6.6	2.33	5.94	2.12	5.92
3 <sup>rd</sup> quartile	3.05	6.01	3.75	6.1	3	5.68	2.38	5.94
4 <sup>th</sup> quartile	5.80	5.78	6.0	5.83	4.17	5.81	4.13	5.43

### 3.3.1.2. The Effect of Demographic Variables on Students' Perception to Entrepreneurship

This section gives an account of the effect of demographic factors such as gender, age, parent's education and income level, parents' employment status, self-employment and startup experience on the perception to entrepreneurship across the students in the survey.

We conducted t-test and ANOVA to determine the direct effects of demographic factors on entrepreneurial intention of the students.

ANOVA was used to test the factors that consist of more than two categories, such as age, mothers' and fathers' level of education, parents' income level whereas t-test was used to test the effect of factors that consisted of only two different categories such as gender, father self-employed, mother self-employed, start-up experience, evaluation of start-up experience and self-employment experience.

But before we employed t-test and ANOVA, we conducted homogeneity of variance test, essentially Levene's test to ensure that the data was appropriate for ANOVA.

As can be seen from table20 and table21, the test results showed that for all the variables homogeneity of variance was maintained to ensure the pertinence of ANOVA for the analysis ( $P < 0.05$ ). We also calculated t-values based on the Levene's test.

Table 20 Analysis of Variance for Perception to Entrepreneurship Test Score (Control Group, 120)

Variable	Constructs							
	Attitude		Subjective norm		Perceived behavior		Intention	
	Leven's statistics	Sig	Leven's statistics	Sig	Leven's statistics	Sig	Leven's statistics	Sig
Gender	1.1123	0.2928	0.0129	0.9095	0.02279	0.8801	0.1576	0.6918
Age	2.626	0.0743	1.184	0.3186	1.836	0.1695	2.838	0.2375
Father Se	2.565	0.1096	0.4885	0.2403	1.4563	0.2289	1.5132	0.1340
Mother Se	0.385	0.5358	3.589	0.0595	1.358	0.2452	0.146	0.3418
Mother Ed	2.105	0.3394	1.031	0.5147	1.053	0.2924	0.591	0.6752
Father Ed	1.213	0.3394	0.274	0.1404	0.5219	0.2309	1.708	0.3168
Income	2.351	0.0979	2.1778	0.1159	1.8259	0.1637	1.456	0.3099
Startup Ex	1.633	0.0752	1.038	0.1260	0.055	0.8141	1.297	0.3384
Start Eva	1.885	0.1824	0.9811	0.3318	1.829	0.1888	1.2679	0.1114

Table 21 Analysis of Variance for Perception to Entrepreneurship Test Score (Entrepreneurship Group, 150)

Variable	Construct							
	At		Sn		Pb		In	
	Leven's statistics	Sig	Leven's statistics	Sig	Leven's statistics	Sig	Leven's statistics	Sig
Gender	0.8979	0.3439	2.9630	0.0868	0.0461	0.8302	2.043	0.1544
Age	1.1870	0.3169	1.0220	0.4058	1.6310	0.1535	1.2120	0.3048
Father Se	1.084	0.2989	0.9027	0.7432	0.6962	0.4051	0.8669	0.3529
Mother Se	0.5090	0.4764	0.2260	0.0740	0.0883	0.7666	0.2961	0.5869
Mother Ed	1.168	0.2068	0.4790	0.1183	0.9380	0.1937	0.6038	0.1664
Father Ed	0.6138	0.4267	1.3480	0.1421	0.1906	0.3852	1.2320	0.2429
Income	0.6540	0.2151	0.9680	0.1196	1.0260	0.3628	1.0740	0.4849
Startup Ex	0.5050	0.0833	1.0380	0.1260	0.0550	0.8141	1.2970	0.3384
Start Eva	1.1880	0.2875	2.0790	0.1634	0.3240	0.3203	0.3826	0.5426

Tables22 and 23 depict the effects of the demographic factors on the constructs of the theory of planned behavior.

Perusal of table22 showed that, on average, respondents in the survey came from the same age group. As a result, we did not find a significant causal relationship between age difference and entrepreneurial intention and its antecedents. For the same basic reason that students in the survey

had no difference in parent's level of education and family income across both the entrepreneurial and control groups ( $p > 0.05$ ), we didn't consider a significant difference in the entrepreneurial intention and its antecedents.

Gender as an entrepreneurial factor has been scrutinized in many past papers (*Literature Review, Chapter 2*). The overwhelming majority alluded that males have a higher entrepreneurial aspirations than females. Nonetheless, the results we found tell a different story about the relationship. It appeared an insignificant causal link between gender and perception to entrepreneurship (Table 22 and 23).

We did this by employing the following two procedures:

First, we compared the dimensions of the theory of planned behavior between entrepreneurship and control groups for a given gender. The results reported that entrepreneurial intention and its constructs between students in the entrepreneurial and control groups were not different for a given gender. For instance the average entrepreneurial intentions for female students in the entrepreneurial and control groups were 2.36 and 2.33 respectively with  $p = 0.7188$  which signifies lack of significance differences between the two groups. This was also maintained for male students.

Second, we then took stock of the within group differences between male and female students regarding their entrepreneurial orientation. It turned out that, despite the group, male and female students didn't show a telling difference in their attitude toward entrepreneurship, subjective norm, perceived behavioral control and intention to entrepreneurship ( $p > 0.1$ ). For instance, the average entrepreneurial intention for male students in the entrepreneurial group was 2.36 while it was 2.27 for female students in the same group ( $p = 0.21$ ).

The result is in fact strikingly interesting. In developing countries like Ethiopia, where it has long been a tradition for females to work family oriented tasks, it is quite appealing to be able to realize similar levels of perception to entrepreneurship between male and female students.

This vindicated, not a full analysis though, the strength (entrepreneurship) education has to change an individual's tendency to career paths. In our analysis, it was considered that male and female students had the same education background before the course. They attended similar courses at least up to the survey time. There were no gender specific courses that could cause a change in male and female students' perception to entrepreneurship. Contrary to this, an assessment of previous studies (*Literature Review, Chapter 1*) showed that the probability of male and female students to

engage in entrepreneurial act had been evaluated in a situation where education had not been controlled for which was indeed against what we followed in this paper.

Table 22 Effect of Age, Fathers’ Level of Education, Mothers’ Level of Education, and Income

Group	Variables	Constructs							
		At		Sn		Pb		In	
		f	sig	f	sig	f	sig	f	sig
Control Group	Age	2.9	0.12	1.6	0.39	1.9	0.23	0.5	0.32
	Feduc	0.7	0.73	2.4	0.13	7.5	0.20	1.7	0.35
	Meduc	2.5	0.09	1.4	0.26	0.84	0.21	1.92	0.33
	Income	2.8	0.07	2.03	0.13	2.6	0.24	2.8	0.06
Entrepreneurship Group	Age	0.80	0.55	0.7	0.59	1.05	0.39	0.87	0.50
	Feduc	2.4	0.36	2.8	0.18	1.5	0.23	1.52	0.31
	Meduc	3.2	0.70	2.2	0.113	1.7	0.23	0.8	0.31
	Income	1.85	0.23	2.25	0.11	0.96	0.38	2.14	0.12

Table 23 Effect of Gender (Comparing females/males between Entrepreneurship and Control group)

	Gender	Entrep. (N=150) Mean	Control (N=120) Mean	(between-group) Sig
At	Female	3.12	3.10	0.8706
	Male	2.85	2.97	0.2942
Sn	Female	3.32	3.24	0.5839
	Male	3.06	3.04	0.8752
Pb	Female	2.59	2.50	0.2265
	Male	2.54	2.55	0.9878
In	Female	2.36	2.33	0.7118
	Male	2.27	2.31	0.6701

Table 24 Effect of Gender (Comparing females/males within Entrepreneurship or Control Group)

Group	Variable & response	Constructs								
		At		Sn		Pb		In		
		Mean	Sig	Mean	Sig	Mean	Sig	Mean	Sig	
Entrepreneurship(150)	Gender	F	3.12	0.197	3.32	0.086	2.59	0.535	2.36	0.21
		M	2.85		3.06		2.54		2.27	
Control(120)	Gender	F	3.10	0.300	3.24	0.140	2.50	0.290	2.33	0.800
		M	2.97		3.04		2.55		2.31	

Perusal of table 25 to 26 inferred that, on average, entrepreneurial orientation of students between the entrepreneurship and control groups was not different given their parents’ self-employment

status ( $p > 0.05$ ). Analysis within the group however showed a significant difference. That is, students from an entrepreneurial parent revealed stronger entrepreneurial aspirations than students who did not have entrepreneurial parent. Students from an entrepreneurial parent scored higher values of attitude toward entrepreneurship, subjective norm, perceived behavioral control and intention to entrepreneurship ( $p < 0.05$ ). This is true for students both in the entrepreneurial and control groups. As social learning theory (*Literature Review, Chapter 1*) posits learning is social context that can come purely through observation or direct instruction. In light of this, children of entrepreneurs have a better proximity advantage to easily learn and develop the skills, knowledge and social networks required of an entrepreneur. Entrepreneurial parents relatively provide a supportive and conducive environment for entrepreneurship. As such it eases the perceived physical or financial capital barriers to would be entrepreneurs. Entrepreneurial parents, therefore, influence their children's entrepreneurial aspirations in two ways as by being a good role model or by providing the necessary startup capital.

Nevertheless, after the course we realized that students from an entrepreneurial parent did not reveal a higher desire to own business than those who didn't have entrepreneurial parents. Observation of the results indicated a significant improvement in the intention to start business for both students after the course. The difference is that students who already had a better entrepreneurial intention prior to the course because of their entrepreneurial parents showed relatively lower improvement in their attitude towards entrepreneurship such as entrepreneurial intention, attitude toward entrepreneurship, subjective norm and perceived behavioral control.

We explained this by the basic fact that students from entrepreneurial parents already had basic entrepreneurial skills, knowledge, resources and social networks which then partially compromises the effect of an awareness creation entrepreneurship education. It is also possible that students with an entrepreneurial parent knew the rough and rugged road their parents went through they are more critical to internalize the materials offered by entrepreneurship education than students who do not have entrepreneurial parent.

Thus, entrepreneurial education that is more efficient for students who did not have any basic entrepreneurial knowledge in this particular case failed to have entrepreneurial parent than those who already had them.

We also provided another line of argument why students with entrepreneurial parents scored relatively less entrepreneurial aspirations than those who didn't have the same just after the course



finished. We contended that entrepreneurship education could provide more and better learning opportunities than self-employed parents have to create the desire to start a business. In the process of taking entrepreneurship course students have the chance to meet alternative and well experienced role models like teachers, and other entrepreneurial professionals who would bring real-life experiences to the classroom which the students could not get before from their parents. This in fact implies also the quest for a strong and supportive culture of entrepreneurship in the social environment across the country.

Table 25 Effect of Fself (Comparing No/Yes between Entrepreneurship and Control group)

	Fself	Entrep. (N=150) Mean	Control (N=120) Mean	(between-group) Sig
At	No	2.87	2.96	0.3023
	Yes	4.6	4.4	0.6213
Sn	No	3.04	3.03	0.9514
	Yes	5.15	5.3	0.2746
Pb	No	2.55	2.49	0.2946
	Yes	2.83	3.11	0.2067
In	No	2.32	2.29	0.6155
	Yes	2.28	2.94	0.0539

Table 26 Effect of Fself (Comparing No/Yes within Entrepreneurship or Control group)

Group	Variable & response		Constructs							
			At		Sn		Pb		In	
			Mean	Sig	Mean	Sig	Mean	Sig	Mean	Sig
Entrepreneurship(150)	Fself	No	2.87	0.000	3.04	0.000	2.56	0.046	2.28	0.021
		Yes	4.40		5.15		2.83		2.32	
Control(120)	Fself	No	2.96	0.000	3.03	0.000	2.49	0.001	2.29	0.007
		Yes	4.6		5.3		3.12		2.94	

Table 27 Effect of Mself (Comparing No/Yes between Entrepreneurship and Control group)

	Mself	Entrep. (N=150) Mean	Control (N=120) Mean	(between-group) Sig
At	No	2.90	2.98	0.3299
	Yes	4.6	5.07	0.2921
Sn	No	3.076	3.075	0.9925
	Yes	5.30	5.39	0.3426
Pb	No	2.55	2.51	0.4346
	Yes	2.89	2.97	0.7762
In	No	2.31	2.30	0.8272
	Yes	2.41	3.06	0.1499

Table 28 Effect of Mself (Comparing No/Yes within Entrepreneurship or Control group)

Group	Variable & response		Constructs			
			At	Sn	Pb	In

			Mean	Sig	Mean	Sig	Mean	Sig	Mean	Sig
Entrepreneurship(150)	Mself	No	2.90	0.000	3.08	0.000	2.55	0.048	2.30	0.045
		Yes	4.6		5.30		2.89		2.42	
Control(120)	Mself	No	2.98	0.000	3.08	0.000	2.51	0.027	2.30	0.002
		Yes	5.06		5.40		2.97		3.06	

Alike parents' self-employment experience, our results also played up the role prior startup experience, positive evaluation of startup experience and self-employment experience had to create the proclivity to entrepreneurship.

Given startup experience prior to the course, entrepreneurial orientation between students in the entrepreneurship and control groups was not apparently different ( $p > 0.05$ ) (table29 and 30). Nonetheless, students with prior startup experience revealed a higher entrepreneurial orientation than those who lacked startup experience ( $P < 0.001$ ). As a matter of fact prior experience pertaining to owning a firm is quite essential to relate the skills and knowledge acquired from school with the real world. It is a good way to gain and develop skills and knowledge through learning by doing which are all but impossible via conventional education. Routines to start a firm usually come about by vicarious learning and experiencing in it. Then aspiring entrepreneurs can acquire valuable insights about developing and financing startups, leading and hiring people, attracting and retaining customers etc.

Similarly observation of table31 to table34 indicated that students with positive valuation of their start-up experience and those who were self-employed prior to the course revealed higher entrepreneurial orientation than students who were short of these aspects ( $p < 0.001$ ). It was however noted that given the positive valuation of their startup and self-employment experience students in the entrepreneurship and control groups possessed the same level of entrepreneurial orientation ( $p > 0.05$ ).

Table 29 Effect of Staexp (Comparing No/Yes between Entrepreneurship and Control group)

Constructs	Staexp	Entrep. (N=150) Mean	Control (N=120) Mean	(between-group) Sig
At	No	2.82	2.85	0.6720
	Yes	4.08	4.34	0.5179
Sn	No	2.99	2.95	0.6026
	Yes	4.51	4.49	0.9411
Pb	No	2.44	2.38	0.0946
	Yes	3.46	3.53	0.4963
In	No	2.16	2.15	0.6466
	Yes	3.42	3.49	0.7785

Table 30 Effect of Staexp (Comparing No/Yes within Entrepreneurship or Control group)

Group	Variable & response		Constructs							
			Attitude		Subjective N		Perceived B		Intention	
			Mean	Sig	Mean	Sig	Mean	Sig	Mean	Sig
Entrepreneurship(150)	Staexp	No	2.82	0.000	2.99	0.000	2.44	0.000	2.16	0.000
		Yes	4.08		4.51		3.46		3.42	
Control(120)	Staexp	No	2.85	0.000	2.95	0.000	2.38	0.000	2.15	0.000
		Yes	4.34		4.49		3.53		3.49	

Table 31 Effect of Stevl (Comparing Negative/Positive between Entrepreneurship and Control group)

	Stevl	Entrep. (N=11) Mean	Control (N=18) Mean	(between-group) Sig
At	Negative	2.27	2.63	0.3439
	Positive	4.69	4.85	0.6355
Sn	Negative	2.78	2.56	0.4405
	Positive	5.09	5.07	0.9190
Pb	Negative	3.06	3.33	0.1228
	Positive	3.59	3.58	0.9263
In	Negative	1.83	1.92	0.6438
	Positive	3.94	3.96	0.5943

Table 32 Effect of Steval (Comparing females/males within Entrepreneurship or Control group)

Group	Variable & response		Constructs							
			At		Sn		Pb		In	
			Mean	Sig	Mean	Sig	Mean	Sig	Mean	Sig
Entrepreneurship(11)	Steval	Neg.	2.27	0.000	2.78	0.001	3.06	0.000	1.83	0.000
		Pos.	4.69		5.09		3.59		3.94	
Control(18)	Steval	Neg.	2.63	0.000	2.56	0.000	3.33	0.000	1.92	0.000
		Pos.	4.85		5.07		3.58		3.96	

Table 33 Effect of SelfEm (Comparing No/Yes between Entrepreneurship and Control group)

	SelfEm	Entrep. (N=150) Mean	Control (N=120) Mean	(between-group) Sig
At	No	2.84	2.92	0.3047
	Yes	4.69	4.95	0.5420
Sn	No	3.04	3.02	0.7851
	Yes	4.93	5.14	0.5468
Pb	No	2.49	2.46	0.4702
	Yes	3.54	3.58	0.7807
In	No	2.21	2.22	0.8906
	Yes	3.66	3.96	0.2503

Table 34 Effect of SelfEm (Comparing No/Yes within Entrepreneurship or Control group)

Group	Variable & response		Constructs							
			At		Sn		Pb		In	
			Mean	Sig	Mean	Sig	Mean	Sig	Mean	Sig
Entrepreneurship(150)	SelfEm	No	2.84	0.000	3.04	0.000	2.49	0.000	2.21	0.000
		Yes	4.69		4.93		3.55		3.66	
Control(120)	SelfEm	No	2.92	0.000	3.02	0.000	2.46	0.000	2.22	0.000
		Yes	4.95		5.14		3.58		3.96	

In conclusion:

The descriptive statistical analysis about the relationship between demographic factors and the dimensions of the theory of planned behavior give valuable insight on how to develop entrepreneurial behavior.

To this end, critical analysis of the descriptive statistics provides three basic results:

First, it was observed that students in the control group had comparable characteristics to students in the entrepreneurship group before the course had started.

Second, notwithstanding the group, students who already had startup experience, positive evaluation of their startup experience, parents' self-employed, students who were self-employed preceding the course revealed a higher perception to entrepreneurship than those who didn't have these experiences.

Finally, we observed that initial entrepreneurship intention that the students acquired prior to the course had considerable effect on the final entrepreneurship intention of students. The implication is that students in the entrepreneurship group who started at lower entrepreneurial intention were subject to a higher improvement in their entrepreneurial intention than those who started a relatively higher level of entrepreneurial intention.

But because these demographic characteristics did not change with the course, we precluded them when working on further model testing or empirical evidence.

### 3.3.2. Hypotheses Testing

#### 3.3.2.1. Structural Equation Modeling (SEM)

We characterized the inter-relationships among attitude towards entrepreneurship, subjective norms, perceived behavioral control and entrepreneurial intention using structural equation modeling (SEM) path analysis using Stata12.0.

The use of the SEM path analysis is pertinent in this study because it enables to estimate simultaneously a series of multiple regression equations derived from the research model to estimate the students' entrepreneurial intentions. It differs from multiple regression analysis in the sense that it can test models with multiple dependents and mediating variables against multiple regression that assumes all independent variables affect the dependent ones **directly** (Anderson & Gerbing, 1988).

Thus, indirect relationships can easily be calculated in the modeling process. In the path model, relationship between any two variables is indicated by a coefficient which is computed by controlling for all other relationships. It also examines the goodness of fit for various nested models. Thus, during estimation process endogenous variables can be taken as both explanatory and dependent variables so that both direct and indirect effects can easily be determined at the same time (Kline, 1998). The indirect effect is just the effect of the explanatory variable on the explained variable through one or more mediating variables (Hoyle, 1995).

Kline (1998) has proposed five basic steps to follow in path analysis:

The first step, **model specification** entails drawing a path model based on the theory of planned behavior and the dataset we had at hand. In this particular case, the path included the dimensions of the theory of planned behavior such as attitude toward entrepreneurship, subjective norm, perceived behavioral control and entrepreneurial intention. Apart from the path, the model can in fact be specified with a set of equations defining the hypothesized relationship among the dimensions of the theory of planned behavior or the four variables. It is thus the cornerstone of SEM analysis where the other steps build on.

The elaborative SEM path diagram for the measurement scale we had proposed in the conceptual framework looks like the one depicted in figure 15 below.

The second step is **identification**: It refers to the relationship between what will be estimated (the parameters) and the information or the dataset used to derive these estimates. Under this situation, any given parameter in a model can be under identified, just-identified, or over-identified.

If a model is identified (i.e., just-identified and over-identified) it is possible to estimate a unique value for every parameter. That is, the model's degree of freedom is equal to or greater than zero. Otherwise, the model is not identified (under-identified). If the model is not identified, it should go back to step 1 to re-specify the model until it becomes identified. In our path model, the degree of freedom was greater than 0 ( $df = 19$ ), and thus, it fitted the identification requirement and we could then proceed to next step.

The third step is **estimation**, where modeling computation occurs. In our study, raw data was used for the analysis. Maximum likelihood estimation (MLE) was used to perform the modeling process. The main purpose at this point is just determining a fitting function that well suits the data.

But the challenge at this stage is that there has not been any single statistical test that best measures the strength of the SEM model fit. Many fitting functions such as Chi-square, Root mean square error of approximation (RMSEA), Standardized root mean square residual (SRMR), and Comparative fit index (CFI) have long been used to test the accuracy of the path model.

The Chi-Square value is one of the traditional measures to evaluate the overall model fit. It measures the difference between the sample and fitted co-variances matrices (Hu and Bentler, 1999:2). According to this statistic, a good model fit would provide insignificant results at a 0.05 threshold (Barrett, 2007).

Researchers are, however, very critical of its application of model fit for its basic assumption of multivariate normality per se implies that deviation from normality may cause rejection of rightly specified model (McIntosh, 2006). In addition, as it is a statistical significance test, it is liable and sensitive to sample size that leads to rejection of the model when large samples are used (Bentler and Bonnet, 1980; Jöreskog and Sörbom, 1993). On the other hand, it lacks power with small samples to identify good from poor fitting model (Kenny and McCoach, 2003). As a solution for the sample Wheaton et al (1977) suggested relative/normed chi-square ( $\chi^2/df$ ) to minimize the impact of sample size on the Chi-Square statistics. Notwithstanding the variations in the acceptance ratio of this statistics, generally it varies from as high as 5.0 (Wheaton et al, 1977) to as low as 2.0 (Tabachnick and Fidell, 2007).

Root Mean Square Error of Approximation (RMSEA) is the second fit statistic reported in Stata program that tells how well the model, with unknown but optimally chosen parameter estimates would fit the population covariance matrix (Byrne, 1998). It is regarded as one of the most informative fit indices that favors parsimony (Hooper et al, 2008; MacCallum et al, 1996). This is in fact possible due to the known distribution values of the statistic and subsequently allows for the null hypothesis (poor fit) to be tested more precisely (McQuitty, 2004). It is generally reported in conjunction with the RMSEA and in a well-fitting model the lower limit is close to 0 while the upper limit should be less than 0.08.

Standardized root mean squared residual (SRMR) is also another fit model with its values range from 0 to 1 where well-fitting models obtaining values less than 0.05 (Byrne, 1998; Diamantopoulos and Siguaw, 2000), though values as high as 0.08 are deemed acceptable (Hu and Bentler, 1999).

An SRMR of 0 indicates perfect fit. But it must be noted that SRMR will be lower when there is a high number of parameters in the model and in models based on large sample sizes.

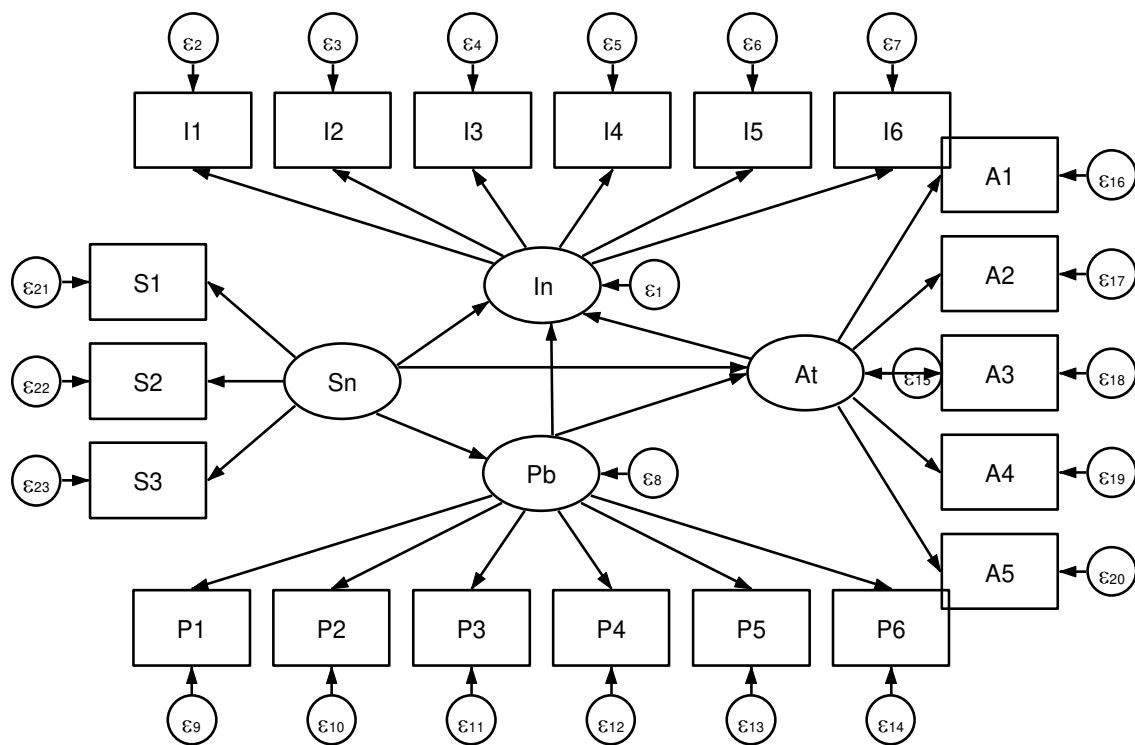

Figure15 SEM path model for the constructs of the Theory of Planned Behavior

Along with SRMR, the coefficient of determination (CD) is also a good indication of the goodness of fit of the model. A perfect fit corresponds to a CD of 1. CD is like R-squared for the whole model.

The other alternative fit index, Comparative Fit Index (CFI) assumes that all latent variables are uncorrelated (null/independence model) and compares the sample covariance matrix with this null model. Values for this statistic range between 0.0 and 1.0 with values closer to 1.0 indicating good fit. A cut-off criterion of  $CFI \geq 0.90$  was initially advanced however, recent studies have shown that a value greater than 0.90 is needed in order to ensure that misspecified models are not accepted. From this, a value of  $CFI \geq 0.95$  is presently recognized as indicative of good fit (Hu and Bentler, 1999). This index becomes one of the most popularly reported fit indices in all SEM programs for its effectiveness even for small sample size (Fan et al, 1999).

The fourth and final step in SEM is re-specification.

When the model fit is found poor, it is necessary to modify and re-specify the model. The re-specification of the model should be primarily guided by theories rather than pure statistical considerations. And the model being re-specified must be identified.

In this dissertation, the path model (i.e., Entrepreneurial intention model) had attained acceptable goodness of fit. Hence, we directly moved to the last step to report estimation results.

We estimated the model using maximum likelihood techniques using Stata12. In fact, our objective here was to confirm the applicability of theory of planned behavior (hypotheses H5-H10). It provides important insights how the constructs of entrepreneurial intention linked with intention. It also shows the way how antecedents of entrepreneurial intention are related to each other.

As depicted on the conceptual framework (figure15), entrepreneurship intention was taken as endogenous variable while subjective norm and perceived behavioral control were used as mediating variables.

Table 35 SEM Results

SEM Results for Control group in T <sub>0</sub>								
Hypotheses	Casual Path	Estimates	z	P- value	Chi/df	CFI	RMSEA	TLI
H5	Sn -> At	0.46	5.36	0.000***	2.34	0.995	0.000	0.992
H6	Sn -> Pb	0.24	4.88	0.000***				
H7	At -> In	0.20	4.20	0.000***				
H8	Sn -> In	0.12	2.68	0.007***				
H9	Pb -> In	0.61	8.04	0.000***				
H10	Pb -> At	0.41	2.63	0.009***				



SEM Results for Control group in T <sub>1</sub>								
H5	Sn -> At	0.35	4.89	0.000***	2.27	0.985	0.05	0.962
H6	Sn -> Pb	0.10	2.40	0.000***				
H7	At -> In	0.20	3.51	0.000***				
H8	Sn -> In	0.15	2.15	0.031**				
H9	Pb -> In	0.33	3.35	0.000***				
H10	Pb -> At	0.47	2.55	0.011**				
SEM Results for Entrepreneurship group at T <sub>0</sub>								
H5	Sn -> At	0.49	7.48	0.000***	2.35	0.987	0.000	0.978
H6	Sn -> Pb	0.18	4.01	0.000***				
H7	At -> In	0.15	2.4	0.016**				
H8	Sn -> In	0.11	2.06	0.039**				
H9	Pb -> In	0.57	6.57	0.000***				
H10	Pb -> At	0.38	2.89	0.004***				
SEM Results for Entrepreneurship group at T <sub>1</sub>								
H5	Sn -> At	0.12	6.32	0.000***	2.02	0.957	0.042	0.954
H6	Sn -> Pb	0.18	2.14	0.000***				
H7	At -> In	0.19	2.32	0.020**				
H8	Sn -> In	0.26	2.30	0.000***				
H9	Pb -> In	0.51	2.47	0.001***				
H10	Pb -> At	0.13	2.18	0.002***				

Note: \*\*\* indicates significant at 1%, \*\* signifies significant at 5%

Using path coefficient and its corresponding p-value, we tested the hypothesis for each path coefficient. Table35 depicts the coefficients of each hypothesized path.

**Hypothesis 5-7: The Greater the attitude toward entrepreneurship, subjective norms and perceived behavioral control with regard to entrepreneurship, the greater the entrepreneurial intention.**

The results of the path coefficients revealed that at both pre-test and post-test students' entrepreneurial intention was significantly influenced by attitude toward entrepreneurship, subjective norm and perceived behavioral control. Parameter estimates for paths occurred in the expected direction between attitude and intention, subjective norms and intention, and perceived behavioral control and intention.

It is apparent that students who reported a strong attitude toward entrepreneurship, subjective norm and perceived behavioral control displayed a higher entrepreneurial intention, and they were thus more likely to pursue entrepreneurship.

The path coefficients of entrepreneurial intention for the control group prior to the course from its three antecedents of attitude, subjective norm, and perceived behavioral control were 0.20 ( $p < 0.001$ ), 0.12 ( $p < 0.01$ ), and 0.61 ( $p < 0.001$ ) respectively. For the same time period, the path coefficients of entrepreneurial intention for the entrepreneurial group from attitude towards entrepreneurship, subjective norm and perceived behavioral control were 0.15 ( $p < 0.05$ ), 0.11 ( $p < 0.05$ ) and 0.57 ( $p < 0.001$ ) respectively. The same trend was also maintained at the end of the course. The path coefficients of entrepreneurial intention for the control group were 0.20 ( $P < 0.001$ ), 0.15 ( $p < 0.05$ ) and 0.33 ( $p < 0.001$ ) respectively for attitude, subjective norm and perceived behavioral control. At the same time, the path coefficients of entrepreneurial intention for the entrepreneurial group were 0.19 ( $p < 0.05$ ), 0.26 ( $p < 0.001$ ) and 0.51 ( $p < 0.01$ ) respectively from attitude, subjective norm and perceived behavioral control.

Consistent with literature (*Literature Review, Chapter 3*), we learned that the strongest path (the one with the highest factor loading or regression weights) was between perceived behavioral control and intention while the weakest path appeared between subjective norm and perceived behavioral control.

Apart from the significant association between the constructs of intention and intention, the results also give evidence on the strength of the association between each construct and intention.

The SEM path analysis once again revealed that the relationships among the 3 antecedents were significantly supported in the conceptual model.

### **H8: Subjective norm influences the attitude of engineering students toward entrepreneurship**

The results of the path analysis at both  $T_0$  and  $T_1$  indicated that attitude toward entrepreneurship, for both groups, was significantly and positively affected by subjective norm. For instance, prior to the course the path Coefficient for the control group was 0.46 with  $P < 0.001$  while it was 0.49 with  $P < 0.001$  for the entrepreneurial group. At the same time at the end of the course the path coefficient for the control group was 0.35 with  $P < 0.001$  whereas the path coefficient for the entrepreneurial group was 0.12 with  $P < 0.001$ .

The influence of subjective norm on attitude toward entrepreneurship provides further empirical evidence on persuasion theory and cognitive dissonance theory. The recommendations/opinions of others regarding an entrepreneurial behavior can be received and internalized by a person influencing his/her consequent decisions on that behavior; or a person may change his or her attitude toward entrepreneurship in order to feel affiliated with significant others (*Literature Review, Chapter3*).

**Hypothesis 9: Subjective norm influences the perceived behavioral control of engineering students toward entrepreneurship**

Subjective norm was found to significantly influence perceived behavioral control with path coefficient=0.24 and  $p<0.01$  for the control group and path coefficient=0.18 and  $P<0.01$  just before the course. The same holds true after the course. The path coefficient for the control group was 0.10 with  $P<0.01$  while it was 0.18 with  $P<0.01$ .

The impact of subjective norm on perceived behavioral control confirms Bandura's social cognitive theory that stresses social persuasions (or social pressure) play an important role in one's capability beliefs. When other people encourage and convince a person to perform a task, she/he tend to believe that she/he is more capable of performing the task. Such encouragement could help the person to overcome self-doubt and concentrate on their effort to perform a task. Thus persuasive comments have significant impact on one's capability beliefs. Effective persuasive comments make people trust in their capabilities and ensure that they have certain control over the behavior (*Literature Review, Chapter3*).

**Hypothesis 10: Perceived behavioral control influences attitudes of engineering students toward entrepreneurship**

The results also suggested that behavioral control had also a significantly positive effect on attitude toward entrepreneurship. Before the course, the path coefficient for the control group was 0.41 with  $P<0.01$  whereas it was 0.38 with  $P<0.05$  for the entrepreneurship group. Correspondingly, at the end of the course, the path coefficient for the control group was 0.47 with  $P<0.05$  whereas it was 0.13 with  $P<0.01$  for the entrepreneurship group.

It is well documented that entrepreneurship is a complex and challenging act that involves huge risks and uncertainties. To this end, skills, abilities, confidence and resources required to cope with the uncertainties and control over the entrepreneurial acts. The higher the perception of control

reflects the more positive evaluation of the entrepreneurial action (i.e., carrying out the entrepreneurial action successfully) an individual will have. As set out in *Literature Review, Chapter3*, evaluation of the entrepreneurial behavior is the belief about the expected consequence of entrepreneurship (i.e., behavioral belief), which reflects one’s attitude toward entrepreneurship. A person who believes that the entrepreneurial action will succeed (i.e., positive outcomes) will hold a favorable attitude toward performing the entrepreneurial behavior. Hence, because of the higher expectancy of the outcomes, higher perceived control over the entrepreneurial behavior reflects more favorable attitude toward the entrepreneurial behavior because of the higher expectancy of the outcomes.

Despite the lack of evidence how the three antecedents influence one another in the formation of entrepreneurial intention, the results confirm the argument that the three antecedents of intention are not independent (*Literature Review, Chapter3*). The findings therefore give additional insights on the impact of the three antecedents on one another.

The results of the overall fit of the resultant model also showed that the structural model fitted the data quite well (table35). For instance, the RMSEA value lies between 0.00 and 0.05 which is within its recommended value for goodness of fit test of the model. In addition, the CFI and TLI values for both samples are close to 1. Both are greater than 0.95 for both samples. The chi-square/degrees of freedom ratios for all the models are between the recommended values 2 and 5. We also checked the statistical significance of indirect effect of endogenous variables through a mediator using Sobel Test (Sobel, 1986). It examines if a mediator variable significantly affects the relationship between an independent variable and dependent variable.

The results of Sobel test are shown in Table36. The results shows that all the indirect effects were significant al a level of 0.001. That is, all the mediators were significant.

Table 36 Results of Sobel test

Path	Sobel Test Statistic
At → Sn → In	0.42(0.000)
Pb → Sn → In	0.79(0.000)
At → Pb → In	0.20(0.000)

These provide further support that the theory of planned behavior was palpably found reliable, robust and valid to deal with the effect of entrepreneurship education on the transition towards entrepreneurship across different groups of students. To this end, the results provide valuable

insights that the TPB model is appropriate to be the basis of our education-entrepreneurial intention model explaining how education affects entrepreneurial attitudes and intention of students.

### 3.3.2.2. Testing the Relationship between Entrepreneurship Education and Intention to Entrepreneurship: Difference-in-Difference Approach

The effect of the entrepreneurship course on entrepreneurial intention of students was analyzed using difference-in-difference (DD) approach. It is one of the commonly used and robust techniques used to examine the effects of policy interventions and policy changes on specific variables of interest.

Obviously evaluating a policy change requires more than a one period dataset. As such, we used data taken at two time periods to compare the average change over time on intention for the entrepreneurial group to the average change over time for the control group. In fact, using data at more than two time points allows elimination of time invariant unobserved variable bias.

The DD approach is robust to solve endogeneity problem that is quite common when making comparison between heterogeneous individuals (Meyer, 1995). It also justifies the reason we used a pre-post research design to identify differences between entrepreneurial and control groups after the course. Using this design allows measuring the true causal effects of the course on entrepreneurial attitudes and intentions. It is then possible to compare the outcome of the entrepreneurial and control group and to differentiate between changes in the outcome variables caused by the course and changes caused by other influences.

We conducted the survey at the beginning and end of the entrepreneurial course. Both the entrepreneurial and control groups were measured on the outcome (dependent variable) at time  $T_0$  before the entrepreneurial group had received the treatment represented by the points E and D. They were then measured at time  $T_1$  after the entrepreneurship group took the course. Not all of the difference between the entrepreneurship and control groups at  $T_1$ , such as the difference between A and B, is the effect of the course, because the entrepreneurial group and control group did not start out at the same point at  $T_0$ . DD therefore calculates the “normal” difference in the outcome variable between the two groups (the difference that would still exist if neither group attended the course), represented by the line EC. (Note that the slope from E to C is the same as the slope from D to B: the parallel trend assumption). The assumption implies that the average change in outcome for the entrepreneurship group in the absence of course equals the average change in outcome for

the non-treated (control) group. That is the differences between the control and entrepreneurial groups are assumed time invariant without the treatment (Angrist and Krueger, 1999). In other words, the control group experiences the same other influences that affected the entrepreneurial group.

The effect of the course is the difference between the observed outcome and the “normal” outcome (the difference between A and C).

Hence, we went about the analysis comparing de facto four groups: the control group before the course, the control group after the course, the entrepreneurial group before the course, and the entrepreneurial group after the course (Figure16). Indeed, it was only students in the entrepreneurship group that took the course and we could observe the effect of the course.

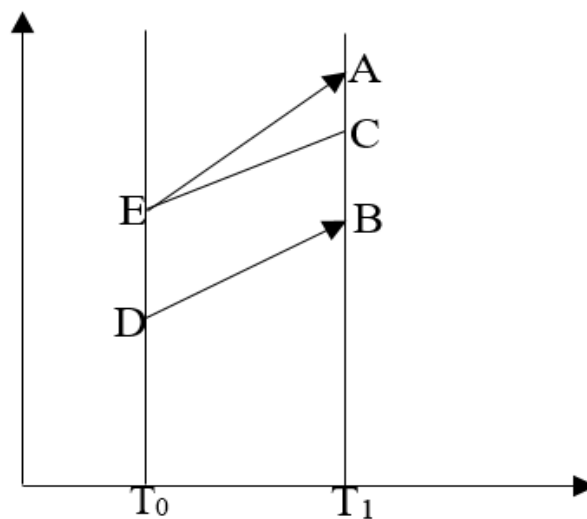

Figure 16 Difference-in-Difference Approach

We used the following regression model to assess the impact of the course on entrepreneurial intention of the students:

$$I_{ni} = \beta_0 + \beta_1 T_i + \beta_2 Treated_i + \beta_3 T_i Treated_i + \varepsilon_i$$

Where,

$T_i$  is a time- period dummy such that  $T_i = 1$  if time = 1 and zero otherwise.

Treated<sub>i</sub> is dichotomous (0 = no; 1 = yes) variable indicating whether individuals have taken an entrepreneurship course or not.

$\beta_0$  is the mean outcome for the control group on the baseline.

$\beta_0 + \beta_1$  is the mean outcome for the control group in the follow-up.

$\beta_0 + \beta_2$  is the mean outcome for the treated group on the baseline.

$\beta_2$  is the single difference between treated and control groups on the baseline

$\beta_0 + \beta_1 + \beta_2 + \beta_3$  is the mean outcome for the treated group in the follow-up

$\beta_3 = (\beta_0 + \beta_1 + \beta_2 + \beta_3 - (\beta_0 + \beta_2)) - (\beta_0 + \beta_1 - \beta_0)$  is the simple DD estimator for the effect of entrepreneurship education on entrepreneurial intentions.

$\varepsilon_i$  is idiosyncratic error.

The simple DD estimator is thus the difference between the average changes in entrepreneurial intentions of students attending entrepreneurship course with students that did not attend entrepreneurship course.

In light of the above, we tested the empirical relationship between entrepreneurship education and intention to entrepreneurship (H1-H4). Table 37 displays the main results of this dissertation study. Column (2) gives the mean values of antecedents of intention variables and intention for the control group at baseline, and column (3) gives the mean values of the antecedents of intention variables and intention for the treatment group at baseline. Column (4) reports the difference between these two columns.

Column (5) shows the mean values of antecedents of intention variables and intention for the control group at the end of the course

Column (6) displays the mean values of antecedents of intention variables and intention for the entrepreneurship group at the end of the course

Column (7) demonstrates the difference between the mean values of antecedents of intention variables and intention between the entrepreneurship and control groups.

Column (8) reports the differences of the differences (column 7 - column 4). We computed the estimates without covariates.

The estimates (column 4) unveiled that students in the entrepreneurship and control groups were not significantly different from each other prior to the course ( $p > 0.05$ ).

The results were however consequentially different at the end of the course (column 8). The average scores of the constructs of entrepreneurial intention and intention per se for the entrepreneurship group were far higher than for the control group after the former had attended the course ( $p < 0.001$ ). The estimates for the impact of entrepreneurship education indicate that the average intention to become entrepreneur after the course was higher by 2.9 for students who took entrepreneurship course than for students who did not. Similarly, attitude toward entrepreneurship, subjective norm and perceived behavioral control were higher respectively by 2.58, 2.4, and 2.7 for students in the entrepreneurial group than students in the control group (column8).

Therefore, with the data we got, entrepreneurship education, though not the only factor, looks effective in enhancing the students' desire and aspirations of starting and owning a business. To this end the results were consistent with the hypotheses stated and the objectives outlined of entrepreneurship education such as increasing the entrepreneurial intention of students who took the course against those who did not take the course.

The findings were also consistent with previous studies. As indicated in *Literature Review, Chapter3*, an overview of 55 studies on the correlation between entrepreneurship education and entrepreneurial intention showed an overly positive result. Furthermore, the results of the analysis here indicated that intention explained around 30% of the variance in behavior. It actually concedes previous studies that found intention explained 30%-55% of the variance in behavior (*Literature Review, Chapter3*).

Findings of the comparison study are valuable as they provide empirical evidence that the entrepreneurship course under study significantly increased the antecedent of attitudes and entrepreneurial intentions of the students.

Table 37 Difference-in-Difference Analysis of the Effect of Entrepreneurial Education

1.Outcome variable	2.Control at T <sub>0</sub>	3.Treated at T <sub>0</sub>	4.Diff(BL)	5.Control T <sub>1</sub>	6.Treated T <sub>1</sub>	7.Diff(FU)	8.DID
A <sub>1</sub>	2.939	2.814	-0.125(0.169)	0.615	3.279	2.664 (0.000)	2.789 (0.000)
A <sub>2</sub>	3.047	2.990	-0.057(0.567)	0.954	3.559	2.604 (0.000)	2.661(0.000)
A <sub>3</sub>	3.595	3.456	-0.140(0.189)	1.520	4.000	2.480 (0.000)	2.619 (0.000)
A <sub>4</sub>	3.274	3.270	-0.004(0.969)	1.419	3.799	2.380 (0.000)	2.384 (0.000)
A <sub>5</sub>	2.645	2.657	0.012 (0.921)	0.808	3.284	2.476(0.000)	2.464 (0.000)



A	3.100	3.037	-0.063(0.497)	1.064	3.584	2.521 (0.000)	2.584 (0.000)
S1	2.991	3.049	0.058(0.570)	1.256	3.843	2.588(0.000)	2.530(0.000)
S2	3.235	3.240	0.005(0.964)	1.451	3.980	2.530(0.000)	2.525(0.000)
S3	3.101	3.142	0.042( 0.673)	1.666	3.961	2.294(0.000)	2.253(0.000)
S	3.109	3.144	0.035( 0.707)	1.468	3.928	2.460(0.000)	2.425(0.000)
P1	2.628	2.676	0.048( 0.699)	1.847	3.745	1.898(0.000)	1.850(0.000)
P2	2.222	2.284	0.063( 0.536)	0.145	2.853	2.708(0.000)	2.646(0.000)
P3	2.218	2.324	0.105( 0.284)	-0.559	2.725	3.285(0.000)	3.180(0.000)
P4	2.313	2.294	-0.019(0.840)	-0.484	2.676	3.160(0.000)	3.179(0.000)
P5	2.281	2.304	0.023(0.828)	0.297	3.108	2.811(0.000)	2.788(0.000)
P6	3.224	3.255	0.031( 0.727)	0.985	3.559	2.574(0.000)	2.543(0.000)
P	2.481	2.523	0.042( 0.508)	0.372	3.111	2.739(0.000)	2.697(0.000)
I1	2.204	2.245	0.041( 0.538)	0.036	2.752	2.717(0.000)	2.676(0.000)
I2	2.344	2.412	0.068( 0.313)	-0.204	2.745	2.949(0.000)	2.881(0.000)
I3	2.482	2.471	-0.011(0.875)	0.050	2.765	2.715(0.000)	2.726(0.000)
I4	2.457	2.402	-0.055(0.446)	0.147	2.951	2.804(0.000)	2.859(0.000)
I5	2.277	2.235	-0.041(0.631)	0.195	2.990	2.796(0.000)	2.837(0.000)
I6	2.246	2.235	-0.011(0.881)	-0.250	2.686	2.936(0.000)	2.947(0.000)
I	2.323	2.319	-0.005(0.923)	-0.076	2.787	2.862(0.000)	2.867(0.000)

*All the estimates depicted in the table come from separate regressions and the values in the brackets corresponds to the respective p-values for the regressions.*

**In Conclusion:**

The results of the structural equation model path analysis and difference-in-difference analysis evidently show that entrepreneurship education is one of the key instruments to ostensibly accentuate the entrepreneurial orientation of students. It was observed that students who attended entrepreneurship course remarkably scored a higher level of entrepreneurial intention compared with those who didn't attend the course, though insignificant before the course. In this connection, though the net effect of demographic variables is nullified, students who had start-up experience, self-employment experience and positive evaluation of previous enterprise experience showed better beliefs to entrepreneurship than those who didn't possess the same before the entrepreneurship group had actually attended the course. On the contrary, age, gender, parent's level of education and income status are unlikely to bring about a significant difference in the entrepreneurial orientation of the students. More specifically, entrepreneurship orientation between/among male and female students, students of different age group, and students from different family background was not significantly different.

Generally, the conceptual model of the thesis was supported. The entrepreneurship education course were found indirectly to affect the entrepreneurial intention of students through the attitude toward entrepreneurship, subjective norm and perceived behavioral control. The results imply that the intervention of entrepreneurship training course exerts a positive influence on the three antecedent attitudes, and thus the intention to start up. Implications derived from the results of this study are discussed in the following section.

### 3.4. Conclusion and Implications of the Study

Entrepreneurship has become one of the buoyant forces fueling economic and social development of many countries. Policy makers and educators have become increasingly aware of that and a great deal of effort has been spent to include entrepreneurship education in the academic domain, at least in the institutions of tertiary education. Accordingly, entrepreneurship education has been mushrooming in the education system all around. For instance, in the last decade over 86percent of universities in Sub-Saharan Africa have instituted a wide range of entrepreneurship education efforts.

At the same time, evaluation of the effectiveness of entrepreneurship education programs in enhancing an individual's entrepreneurial perception has then become of compelling and worthwhile research interest among researchers in the last two decades. On the other hand our assessment of impact studies that have done thus far triggers for further rigorous studies on the impact of entrepreneurship education on entrepreneurial intention of the participants. Rigor and robustness relatively voided from the studies and made the exact effect of offering entrepreneurship education unclear. The findings of our literature review evinced an unduly positive impact of entrepreneurship education courses or training programs on perception to entrepreneurship. Around 86% of the studies (49 out of 57) indicated a positive result with the remaining 8 studies evidenced negative or insignificant result. A critical assessment of the studies that show positive result revealed some basic methodological limitations. Most studies were mainly ex-post examinations that failed to measure the direct impact of entrepreneurship education program. Our observation of the 49 studies gave evidence that 73.5% (36 studies) employed ex-post design. They were also short of any comparable control groups or stochastic matching to understand the change on the experimental group. It is considered that around 63.3% (31/49 studies) failed to include control groups in their research design. It is also considered that though there had been some studies that

followed pre- post design with control groups, the majority of them failed to have an optimum sample size. Out of the 6 studies that revealed positive result and applied a pretest-posttest analysis with control group, only two studies managed to engage an experimental group with more than 100 samples. In addition, the majority of the studies were conducted in economies at advanced stages of development, with quite limited focus on least developed countries. The preliminary assessment once again indicated that out of the 57 studies overviewed only 4 were on least developed countries. Finally, the studies were apparently biased to business and economics students. Non-business students such as natural science and engineering students had not been the focus of such studies, save the fact that this group represented the bulk of entrepreneur society all around. Studies from the latter group were very few. The literature survey unveiled that less than 10% (5 studies) sampled engineering students.

This study was thus framed to redress this challenge. It aimed to synthesize the impact of entrepreneurship education course in a sample of 270 engineering students (150 entrepreneurial and 120 control group students) at Debre Berhan University in predicting their entrepreneurial behavior in a pre-post design drawing on the theory of planned behavior model. Among the basic intention models critically reviewed in the literature (*Literature Review, Chapter3*), the theory of planned behavior was found valid and robust to give better information about the formation of entrepreneurial intention. At the same time, entrepreneurship is a planned behavior and that a new business is rarely created suddenly without planning, and thus it is best predicted by entrepreneurial intention.

But before we parsed the relationship between entrepreneurship education and perception to entrepreneurship, we synthesized should background of students influence proclivity to entrepreneurship. The findings gave critical evidence on the state of entrepreneurial intention of an individual. It is considered that entrepreneurship is not such an easy that everyone who wishes to own a firm manages to make a go of it though being entrepreneurial is not mysterious exclusively preserved for a specific group of people. Our pre-entrepreneurship education course analysis indicated that students who had previous start-up experience had percussions in the probability of owning a firm in the future. Students who had some start-up experience in different ways before the course started showed better entrepreneurial perception than those who did not have the same experience. At the same time, the effect of the course on the former then became moderate

compared to the latter group which in fact would have great implications for entrepreneurship education policy design and implementation.

The other interesting result we found in our analysis was the relationship between intention to entrepreneurship and gender of an individual. Contrary to previous studies that alluded a higher probability of male compared with female tended to engage in entrepreneurial act, this study evidenced an almost similar perception to entrepreneurship between male and female students. The only considerable difference between this study and similar studies was that in this study we controlled for education. In this regard, it prompts policy makers target education as an indispensable tool to bring about gender equality in entrepreneurial act.

When we consider the education-entrepreneurship relationship, the findings emphatically provide critical discernments to spearheading entrepreneurship and developing theories pertaining to entrepreneurial intention.

Consistent with previous works (*Literature Review, Chapter 3*), the empirical analysis confirms the credibility of the theory of planned behavior to predict entrepreneurial intention which was actually explained by the three antecedents of intention such as attitude toward entrepreneurship, subjective norm, and perceived behavioral control with the latter one came out as the strongest and principal predictor of entrepreneurial intention.

Given the strong association between the antecedents and entrepreneurial intention, the study reckons that entrepreneurship education aiming to improve entrepreneurial intention should pay due attention to accentuate the students' attitude towards entrepreneurial activity, subjective norm and perceived behavioral control.

For that matter the course had the intended effect of significantly influencing the three antecedents of entrepreneurial intention and intention per se. By comparing the two groups of students (entrepreneurship and control group), the study unveiled that the entrepreneurship course was effective to improve the entrepreneurial perceptions of engineering students. Students who had been exposed to the course had significantly higher level of entrepreneurial perceptions (including attitude toward entrepreneurship, subjective norm, perceived behavioral control, and entrepreneurial intention) than the control group students ( $P < 0.05$ ).

But the effect of the course was not homogenous across students. It was considered that post-entrepreneurial-education intention was highly related to the level of pre-entrepreneurial education intention. For students in the first quartile (those participants who started with low values in the

constructs of the theory of planned behavior), the impact of the entrepreneurial training course is significantly positive and much greater than those in the fourth quartile students (those having the highest level of entrepreneurial intention). Its impact on the latter one is quite meager.

The findings thus recall policy makers and educators to be cautious about the nature of entrepreneurship education course / or program/ or training they prepare and offer for the students. A preliminary assessment of the level of attitudinal constructs of the theory of planned behavior of the students before the course is but such an important step to follow to be aware of the nature of the course and optimize the intended objectives.

The practical contribution of this study is thus reflected on its implication for designing and delivering an effective entrepreneurship course. The positive relationships between entrepreneurship education and the variables of the theory of planned behavior gave important evidence for people who have a stake in entrepreneurship education policy on the areas of priority. It propels them to invest and work in the development of a systematic entrepreneurship education model that enhances the three antecedents of intention through which entrepreneurial intention and behavior then come about.

The study also investigated the relationships among the constructs of the theory of planned behavior. It unveiled that the constructs of entrepreneurial intention are not distinct. Attitude toward entrepreneurship was significantly explained by subjective norm and perceived behavioral control while perceived behavioral control was once again significantly explained by subjective norm. As explained in literature, chapter 3, the findings for the former one were in line with persuasion theory of Eagly and Chaiken and Bandura's social learning theory. That is, persuasive opinions or recommendations of significant others can evoke existing beliefs and attitudes of students toward entrepreneurship while the acknowledgement or encouragement of the entrepreneurial professionals will lead to stronger perceptions about self-capability to exert control over the entrepreneurial event. Furthermore, Bandura's Perceived behavioral control significantly influences attitude toward entrepreneurship. That is, the higher level of behavioral control that one perceives (i.e., the more easily one thinks that he/she is able to carry out an entrepreneurial behavior), the more positive evaluation of the possible outcomes associated with entrepreneurship will be expected (i.e. higher desirability to start up).

Most entrepreneurship education studies have mainly focused on the direct relationships between the antecedents of intention and intention disregarding the inter-relationships among the three

antecedents that will provide valuable insight into how each construct contributes to the formation of entrepreneurial intention and offer significant guidelines for designing effective entrepreneurship courses/programs.

The indirect interrelationships among the antecedents intention have a very important policy implication. Though we considered different magnitudes of the effects of the antecedents of intention on intention, the correlation and causation among them remind policy makers to give due attention to promote all the antecedents.

Thus, the findings of this study contribute to the reliability and validity of the theory of planned behavior by providing additional empirical evidence in the context of entrepreneurship research.

### **Limitations of this study**

Although we were very cautious to ensure rigor in both the design and the analysis of this study, we believe that the generalizability of our findings may be limited in some ways and the reach of the results obtained in the study undertaken should be interpreted under certain methodological restrictions.

Though the study applied pre-post design to measure the change in the antecedents of intention and intention per se ascribed to the course, it did not consider the stability of these changes overtime. The length of entrepreneurship education course/ training can vary a lot across circumstances. The effect on the constructs of intention and intentions toward entrepreneurship may also equally vary among the participants. The impacts of the course/ training may not also be apparent until sometime after the completion thereof. In this regard, further longitudinal analyses are needed to give an account of the development of the entrepreneurial intention into a tangible form of new and successful venture.

Furthermore, the question of when to deliver entrepreneurship education is the other caveat this study faces. In this very moment, it only targeted entrepreneurship education offered at university level. Entrepreneurship education can however be delivered at different levels of the education system or work settings. And its effect might be even greater than it has at university level. Thus, further research that aims to understand the impact of entrepreneurship education across different education levels or work settings is of great significance.

Moreover, though great care was taken when reviewing the existing studies to apply robust method to the analysis of the data recorded, taking practical reality in to account bring some limitation to

the study. The design of the study was set up to overcome methodological deficiencies in previous studies by utilizing pre-post sampling and control groups with a sample more than the recommended minimum requirements. However it can be argued that the internal validity comes at a cost: the lack of external validity. The sample was restricted to students from one University. The external validity of the results has to be questioned. A solid conclusion about the causality in the intention-behavior link of the theory of planned behavior model is only possible when the study result is replicated on a wider sample. Hence, future studies are required to validate and confirm the empirical findings and test the generalizability of the study with different samples such as a larger, preferably nationwide or even international samples.

Finally, the study was set out only to assess the impact of entrepreneurial course on students' entrepreneurial intention. However, the impact of other exogenous factors such as the variability of the course content, teaching methods and design of the entrepreneurship would be an invaluable means of developing the area further.

### **Suggestions for future research**

The caveats of the current study inevitably leaves the door open for further research to advance our knowledge of the relationship between entrepreneurship education and entrepreneurial intention.

First, the results of the study indicated that the impact of entrepreneurship education was a function of the profile of the participants prior to the course. Hence, a study conducted to review the kind of entrepreneurship education program that should be offered for a specific group of participants merits more attention from researchers. The whole field of entrepreneurship education research will benefit from a realistic assessment of what objectives of entrepreneurship education are appropriate for which education level.

After confirming the kind of entrepreneurship program/ training / course to be offered for the different target groups, the way to impart entrepreneurship education such as content, design and delivery for each group of participants will also be an insightful research area to develop further.

Second, the duration of entrepreneurship education programs can differ among providers and may have different impact on perception toward entrepreneurship. Thus the effects of time and duration on entrepreneurial intention and its antecedents is of great interest for education scholars because these areas relate to effectiveness and resource utilization. Thus a longitudinal research merit further in-depth research.

Third, future research is also well advised to examine the relationship between entrepreneurship education and the theory of planned behavior with national and international samples.



## Literature Review

### Chapter 1: An Overview of Entrepreneurship Scene

1.1 Introduction 1.1.1 The Concept of Entrepreneurship 1.2 Individual Determinants of Entrepreneurship 1.2.1 Gender 1.2.2 Age 1.2.3 Education Level 1.2.4. Working Status 1.2.5 Income Status 1.2.6 Self-Assessed Business Skills 1.2.7. Social Ties 1.2.8. Fear of Failure

#### 1.1. Introduction

##### 1.1.1. The Concept of Entrepreneurship

Seminars, conferences and journal articles on entrepreneurship are proliferating more than ever. It becomes a matter of importance among academicians and policy makers around the world. A great deal of work has long been done to tackle the challenges it faces and effectuate the objectives set aside of it, otherwise.

It is widely acknowledged, however, that defining the concept entrepreneurship is not easy and remains elusive. It still lacks a single, unified and generally accepted definition that manages to address the whole process of entrepreneurial activity.

The definitions vary with the focus and the perspective one looks at entrepreneurship from. They are so scattered and numerous. There is no such thing as easy as finding an entrepreneurship definition across researchers.

The definitions are in fact not specifically contained within any single academic domain; rather span broad range of disciplines. The definition of entrepreneurship, thus, depends on the disciplinary approach of the researcher defining it and the objective of the research undertaken. Many disciplines such as Psychology (Shaver and Scott, 1991), Sociology (Reynolds, 1991; Thorton, 1999), Economics (Cantillon, 1755; Marshall, 1890; Knight, 1921; Schumpeter, 1934) and Management (Stevenson et al., 1985) have a big stake in the concept of entrepreneurship.

In a review of journal articles and text books over a five year period, Morris (1998) found 77 different definitions for the term entrepreneurship. Similarly, Garner (1990) reviewed materials related to the concept entrepreneurship and came up with 90 different attributes associated with entrepreneur.

It can thus be seen from the above analysis that entrepreneurship is such a multidimensional and heterogeneous concept. To address and simplify the jargons, however, researchers added various adjectives to the word entrepreneurship such as “corporate entrepreneurship”, “social entrepreneurship”, “opportunity entrepreneurship” and “necessity entrepreneurship” (Gedeon, 2010).

From a historical perspective, the term “entrepreneurship” reaches back to Richard Cantillon (1608-1734), in his (posthumous) publication “Essai sur la Nature du Commerce en Général” or “Essay on the Nature of Trade in General” in 1755. He was the pioneer to fully recognize, coin and take notice of the substantial role entrepreneurship and entrepreneur play in the economic system. In his view, entrepreneurship is at the crux of the economic cycle that embraces the whole production, distribution, and exchange of goods in the economy to meet discontinuities in the market.

He also claimed that the impetus for an entrepreneurial act is fundamentally pecuniary. Entrepreneurs engage in an entrepreneurial act expecting profit from purchasing, if not producing, at a certain and known price at present and selling at uncertain better price in the future. Needless to say, the entrepreneur undoubtedly engages in pure arbitrage that indeed involves risk and uncertainty. To this end, entrepreneur was defined as self-employed in any sort who is willing to assume the risks of purchasing items at certain prices in the present to sell them at uncertain prices in the future.

After Cantillon many prominent scholars have tried to work on his contributions and came up with some elaborative and various concepts of the terms entrepreneur and entrepreneurship (table 38).

A perusal of the table indicates a greater deal of diversity among the definitions of entrepreneurship and entrepreneur. They are substantially linked to various aspects and concepts.



**Figure17 Aspects of Entrepreneurship**  
**Source: Own Compilation**

The field entrepreneurship involves pursuit and exploitation of discontinuous opportunity. Opportunity recognition is the foundation and very first step for entrepreneurs to conceive and envision the notion of a successful venture. The opportunities then come up as new and value adding

goods and services, market, or methods to the economic system. In this sense, entrepreneurs are always alert and on the spot to search for untapped opportunities, and put them at their best use by selling them in a different place, at a different time, or in a different form.

Entrepreneurs naturally engage in entrepreneurial act expecting promising return from the act, in different forms though. Notwithstanding the inevitable challenges to run a successful business, entrepreneurs are always considered to be an inveterate optimist about the future. They always believe that acting on an entrepreneurial opportunity pays off. Accordingly, they are able to think beyond the current rules, resources and challenges to see a different way of working. In fact they are not such a naïve to accept everything. They usually take enough time, gather critical information and analyze the dynamicity in the market. In this regard, they take risks without maximizing it. The very nature of this behavior gives them a superior advantage to forecast market fluctuations and identify price differences across time. In the word of psychologist Martin Seligman (1991) entrepreneurs develop “learned optimism”, in which they believe successes are the result of their own hard work while seeing setbacks as external and temporary hurdles they need to overcome. This gives entrepreneurs a maverick character to appreciate market disequilibrium that perceptibly causes a change in price which is at the center of a pecuniary motive of entrepreneurs.

Entrepreneurship is also interpreted as a process driven by individuals rather than a one-off event, action or decision. Venture formation is not such an easy to come by. It requires of the entrepreneur to prevail over many restraining factors and rocky roads ahead that demand persistence and perseverance.

Given such a situation, it is thus evident that entrepreneurship process is a cycle that involves perception of an opportunity (Conception), evaluation of the opportunity (gestation phase), firm creation (infancy phase) and maturation (adolescence phase) (Reynolds, 1993:14). Hence, the decision to put together a concrete plan, start, manage and lead a new firm is just a part of the actions that the entrepreneur should undertake to effectively discover, evaluate, and exploit an opportunity. The diagram more specifically depicts the courage, stamina and determination within the entrepreneurship ecosystem (figure18). There is no point where the system finishes; with just every ending there is a new beginning.

Furthermore, it is also claimed that entrepreneurship is based on continuous creativity. It entails process of creating something different from the rather routine one. A product /or service that is perfect for the demands of the market. Of importance at this point is that the entrepreneur should

pioneer a value adding change that fills the gap in the market. The entrepreneur shall fanute nothing into something. The end result involves unveiling new ideas and knowledge to arrange resources in a rather new way. The innovation act, as mentioned above, then comes out as a new product or service, improvement in the quality of an existing product or service, or an introduction of an efficient process or method to triggering productivity. Hence, it is apparent that innovative ideas per se are not enough for an entrepreneurial act.

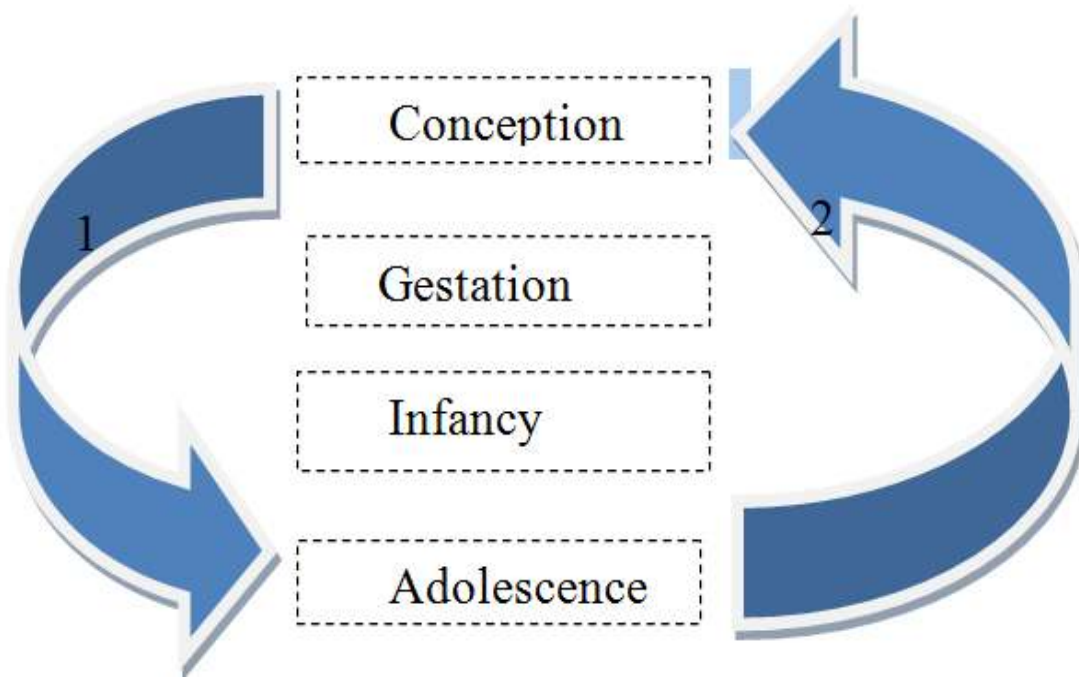

Figure 18 Phases of Entrepreneurial Process

At the end, unsurprisingly, the critical part in the whole entrepreneurial cycle is the entrepreneur. The entrepreneur is the individual tellingly responsible for the entire entrepreneurial act. All the innovations are indeed created by the creativity and visions of individuals and are not solely the result of a rational, well planned process. In this regard entrepreneur is a visionary actor who envisages new angles, ways, rules, culture, and

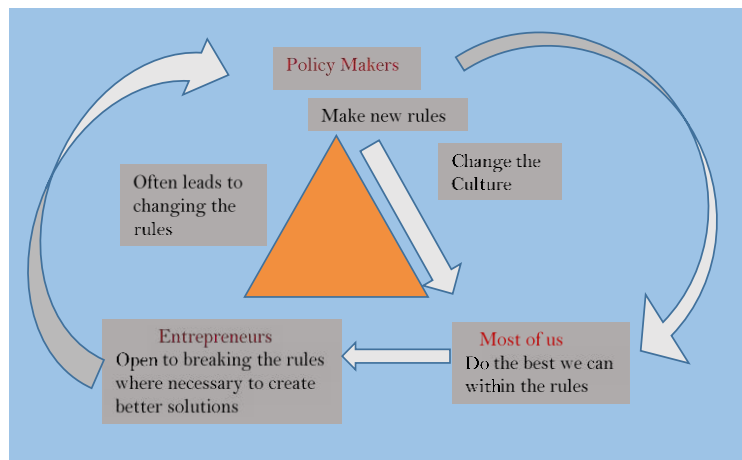

Figure19 The Entrepreneurial Thinking, Based on NewSchools Venture Fund

opportunities that lead to the creation of something new, valuable and different in a risky and uncertain environment.

Figure 19 shows how an entrepreneur functions in a new, different and value adding way given the constraint they face from policy makers and business environment.

Table 38 Summary of the Different Definitions of Entrepreneurship and Entrepreneur

<i>Author</i>	<i>Definition</i>
Cantillon, 1755/1931	Entrepreneurs buy at certain prices in the present and sell at uncertain prices in the future. The entrepreneur is a bearer of uncertainty.
Say, 1816	The entrepreneur shifts economic resources out of an area of lower and into an area of higher productivity and greater yield. The agent who unites all means of production and who finds in the value of the products.... the re-establishment of the entire capital he employs, and the value of the wages, the interest and the rent which he pays, as well as the profits belonging to himself.
Hawley, 1907	Risk taking is the essential function of the entrepreneur. Proprietorship is the essence of entrepreneurship. “... the profit of an undertaking, or the residue of the product after the claims of land, capital, and labor are satisfied, is not the reward of management or coordination, but of the risks and responsibilities that the undertaker... subjects himself to.... profit is identified with the reward for the assumption of responsibility, especially, though not exclusively, that involved in ownership.”
Knight, 1921, 1942	Entrepreneurs attempt to predict and act upon change within markets. The entrepreneur bears the uncertainty of market dynamics
Weber, 1947	The entrepreneur is the person who maintains immunity from control of rational bureaucratic knowledge.
Schumpeter, 1934	The entrepreneur is the innovator who implements change within markets through the carrying out of new combinations. These can take several forms: · the introduction of a new good or quality thereof, · the introduction of a new method of production, · the opening of a new market, · the conquest of a new source of supply of new materials or parts, and · the carrying out of the new organisation of any industry.
Ely and Hess, 1937	Entrepreneurs are people who assume the task and responsibility of combining the factors of production into a business organization and keeping this organization in operation... he commands the industrial forces, and upon him rests the responsibility for their success or failure.
Evans, 1949	Entrepreneurs are people who organize, manage, and actively control the affairs of the units that combine the factors of production for the supply of goods and services.
Baumol, 1968	Entrepreneur is an individual who exercises what in the business literature is called ‘Leadership’.
von Mises, 1949/1996	Entrepreneur is always a speculator who deals with the uncertain conditions of the future.
Walras, 1954	The entrepreneur is coordinator and arbitrageur.
Hoselitz, 1960	The entrepreneur is one who buys at a price that is certain and sells at a price that is uncertain.
A. Shapero, 1975	Entrepreneurs take initiative, accept risk of failure and have an internal locus of control
Kanbur, 1979:773	Entrepreneurs are those who manage the production function by paying workers’ wages (which are more certain than profits) and shouldering the risks and uncertainties of production

Kirzner, 1973	Entrepreneur recognizes and acts upon opportunities, essentially an arbitrageur.
Brockhaus, 1980	An entrepreneur is defined as a major owner and manager of a business venture not employed elsewhere.
Hull and Bosley, 1980	Entrepreneur is a person who organizes and manages a business undertaking assuming the risk for the sake of profit.
Woolf, 1980	Entrepreneur is one who organises, manages, and assumes the risks of a business or enterprise
Mescon and Montanari, 1981	Entrepreneurs are founders of new businesses.
Casson, 1982, 2003	An entrepreneur is someone who specializes in taking judgmental decisions about the coordination of scarce resources.
Kirzner, 1985	An entrepreneur is one who perceives profit opportunities and initiated action to fill currently unsatisfied needs.
Goffee and Scase, 1987	Entrepreneurs are risk-takers and innovators who reject the relative security of employment in large organizations to create wealth and accumulate capital
Hebert and Link, 1988	Entrepreneurs 1) assumes risk associated with uncertainty, 2) supplies capital, 3) innovator, 4) decision maker, 5) leader, 6) manager, 7) organizer and coordinator, 8) owner, 9) employer of factors of production, 10) contractor, 11) arbitrager, 12) allocator of resources.
Bygrave and Hofer, 1991	An Entrepreneur is someone who perceives an opportunity and creates an organization to pursue it.
Carland and Carland, 1997	Entrepreneur is an individual who pursues the creation, growth or expansion of a process, business, venture or procedure which can lead to the realization of that individual's dream.
Cason et al., 2006	Entrepreneur is the founder or owner-manager of a small or medium-sized enterprises (SMEs) with growth potential
McClelland, 1961	Entrepreneurial activity involves (a) risk-taking, (b) energetic activity, (c) individual responsibility, (d) money as a measure of results, (e) anticipation of future possibilities, and (f) organizational skills.
Soltow, 1968	Entrepreneurship comprises 'a more or less continuous set of functions running from the purely innovative toward the purely routine,' performed within business firms or other agencies 'at many levels of initiative and responsibility,... wherever significant decisions involving change are made affecting the combination and commitment of resources under conditions of uncertainty'."
Cole, 1968	Entrepreneurship is purposeful activity to initiate, maintain and develop a profit oriented business
Leibenstein, 1968	Entrepreneur is one who marshals all resources necessary to produce and market a product that answers a market deficiency.
Palmer, 1971	The entrepreneurial function involves primarily risk measurement and risk taking within a business organization.
Penrose, 1959/1980	Entrepreneurial activity involves identifying opportunities within the economic system
Vesper, 1982	Entrepreneurship is defined as the creation of new business enterprises by individuals or small groups.
Stevenson, 1983	Entrepreneurship is a process by which individuals pursue and exploit opportunities irrespective of the resources currently controlled
Backaman, 1983	Entrepreneurial firms are thought to be more innovative
Drucker, 1985	Entrepreneurship is an act of innovation that involves endowing existing resources with new wealth-producing capacity.
Gartner, 1985	Entrepreneurship is the creation of a new organisation
Burch, 1986	Entrepreneurship is a process of giving birth to a new business
Gartner, 1989	Entrepreneurship is the process by which new organizations come into existence.

Hisrich and Peters, 1989	Entrepreneurship is the process of creating something different with value by devoting the necessary time and effort, assuming the accompanying financial psychic and social risks and receiving the resulting rewards of monetary and personal satisfaction.
Stevenson and Jarillo, 1990	Entrepreneurship is the process by which individuals pursue opportunities irrespective of existing resources.
Kaish and Gilad, 1991	Entrepreneurship is the process of first, discovering, and second, acting on a disequilibrium opportunity.
Churchill, 1992	Entrepreneurship is the process of uncovering and developing an opportunity to create value through innovation and seizing that opportunity without regard to either resources (human and capital) or the location of the entrepreneur – in a new or existing company.
Herron and Robinson, 1993	Entrepreneurship is the set of behaviours that initiates and manages the reallocation of economic resources and whose purpose is value creation through those means.
Lumpkin and Dess, 1996	Entrepreneurship is a process of new entry– by entering new or established markets with new or existing goods or services.
Venkataram, 1997	Entrepreneurship is the scholarly examination of how, by whom, and with what effects opportunities to create future goods and services are discovered, evaluated, and exploited.
Reynolds et al., 1999	Entrepreneurship is any attempt at new business or new venture creation, such as self-employment, a new business organization, or the expansion of an existing business, by an individual, a team of individuals, or an established business
Shane and Venkataraman, 2000	Entrepreneurship a process by which opportunities to create future goods and services are discovered, evaluated, and exploited.
Hitt et al. ,2001	Entrepreneurship can be seen as part of the management function within existing firms.
Antoncic and Hisrich, 2001:495	Entrepreneurship is the pursuit of creative or new solutions to challenges confronting the firm.
Commission of the European Communities, 2003	Entrepreneurship is the mindset and process to create and develop economic activity by blending risk-taking, creativity and/or innovation with sound management, within a new or an existing organisation.
Hart, 2003:5	Entrepreneurship is the process of starting and continuing to expand new businesses.
Ireland et al., 2003	Entrepreneurship is a context-dependent social process through which individuals and teams create wealth by bringing together unique packages of resources to exploit marketplace opportunities.
Oviatt et al., 2005	Entrepreneurship is “the discovery, enactment, evaluation, and exploitation of opportunities . . . to create future goods and services”.
Davidsson, 2006	Entrepreneurship is the creation of new economic activity that occurs both through the creation of new ventures and new economic activity of established firms
Ahmad and Hoffmann, 2008	Entrepreneurial Activity is the human action in pursuit of the generation of value, through the creation or expansion of economic activity, by identifying and exploiting new products, processes or markets
Ahmad and Seymour, 2008.	Entrepreneurship is the phenomenon associated with the entrepreneurial activity, i.e. the enterprising human action in pursuit of the generation of value, through the creation or expansion of economic activity, by identifying and exploiting new products, processes or markets.
GEM	Entrepreneurship is “... any attempt at new business or new venture creation, such as self-employment, a new business organization, or the expansion of an existing business, by an individual, teams of individuals, or established businesses”
Hessels et al., 2008	Entrepreneurship is the creation of something new

It can be considered from the above analysis that the range of definitions suggested to entrepreneurship and entrepreneur evidently indicate the multidimensionality of the concepts. They integrate different disciplines across the academic discourse. The very nature of multidimensionality and multidisciplinary nature of entrepreneurship and entrepreneur rather widens the research opportunities in the area. Many research questions have long been sparking in the minds of entrepreneurship scholars based on the perspective they have viewed it from.

McGrath (2003) noted that the study of entrepreneurship has fundamentally to do with the study of economic change. Lundstrom and Stevenson (2005) noted that entrepreneurship research incorporates the study of the dimensions of the entrepreneurial process and the behaviors and practices of the total system that lead to the emergence of entrepreneurial activity in a society. In this sense, entrepreneurship study integrates various actors and organizations.

Avnimelech et al (2011) considered two main paths of academic research approaches to entrepreneurship. The first path tries to explain the very basic reason a person decides to be an entrepreneur. It considers the characteristics of individuals engaging in an entrepreneurial activity. This is referred to as the micro-psychological approach to entrepreneurship research. The second explains regional variation in venture formation at an aggregate level along with normative, structural and institutional variations in geographical areas. This is referred as the macro opportunity approach to entrepreneurship research.

On the other hand, to Shane and Venkataraman (2000) three basic and more comprehensive research questions take the center stage of the entire entrepreneurship research:

1. Why, when and how opportunities for the creation of goods and services come in to existence
2. Why, when and how some people and not others discover and exploit opportunities ; and
3. Why, when and how different models of action are used to exploit entrepreneurial opportunities.

Many people oftentimes come up with very great ideas, but only a handful of them have the gumption to follow through with them. People go after these ideas in quite different ways. Some act on and execute the opportunities quite successfully while others go up in smoke. It is sort of, as in the biblical parable, “many are called but few are chosen”. Understanding the reasons for the difference in entrepreneurial success has still been an unresolved challenge among researchers.



To this end, of critical importance to our literature survey is the second question Shane and Venkataraman raised: why, when and how some people and not others discover and exploit opportunities. It is a holistic question that can just consider the nature and characteristics of individuals who aspires to become entrepreneurs. In this sense, it assesses the success factors and the very fundamental challenges entrepreneurs face on their day to day entrepreneurial endeavor. The next sections thus examine extant literature that essentially helps to tackle these issues. The first part basically focuses on discussing the relationship between entrepreneurship and individual characteristics of potential entrepreneurs. In the second part, we spanned the full spectrum on reviewing literature on the possible relationship between entrepreneurship and business climate. Finally, we explore the role of entrepreneurship education on entrepreneurial intention. It also discusses the corresponding entrepreneurial intention theories that help to develop the appropriate theoretical framework for the study.

## 1.2. Individual Determinants of Entrepreneurship

*“The entrepreneurial journey starts with jumping off a cliff and assembling an airplane on the way down.” Reid Hoffman, founder of LinkedIn*

It is well documented in the academic research that the decision to start a firm has been attributed to range of intricate factors. Pursuing an entrepreneurial career is far from random. It is not so easy that everyone who wishes to own a firm manages to make a go of it. At the same time, as outlined so far, being entrepreneurial isn't the exclusive preserve of a specific group of people. There is no single recipe at all to be an entrepreneur.

On the face of it, starting a business is a daunting task that requires people to deal with a varied assortment of issues. Hence to better understand the nature and obstacles to thriving entrepreneurship, assessing the individual characteristics of entrepreneurs takes priority in entrepreneurship research.

The following section looks up how individual factors play in shaping the probability of becoming an entrepreneur by briefly reviewing what other studies concluded on the same.

### 1.2.1. Gender

It is now well accepted that entrepreneurship is not a gender-neutral act. A tremendous gender bias exists in entrepreneurial work. This bias is reflected in a higher probability of men in comparison to women to step into entrepreneurship.

An examination of table39 indicates that notwithstanding the changes in time, country or sample used in the study, in all the 21 studies we analyzed men were highly likely to engage in an entrepreneurial act than women. Men were two or so times more likely than women to own their own business.

Various lines of arguments came out of literature on why in many circumstances men out participate women on entrepreneurial acts. Some research related the relatively lower participation of women in entrepreneurial act with the attitude they have to risk of failure. It is noted that women are more risk averse than men (Arano et al, 2010; Bernasek and Shwiff, 2001; Booth and Nolen, 2012; Borghans, Golsteyn et al, 2009; Rachel and Uri, 2009).

Using their retirement asset allocation, Arano et al (2010), for instance, examined the risk aversion state of married households with joint investment decision making. The result suggested that gender differences are a significant factor explaining individual retirement asset allocation with a higher risk averse nature of women than their male spouse.

Results from a three-year study carried out by psychological consultancy limited (2012) on over 20 occupational sectors across four continents using around 2000 individual assessments with people from a wide range of professions concluded that women are less likely to take risks. Females were more than twice as likely to be wary and almost twice as likely to be prudent whilst males were more than twice as likely to be adventurous and almost twice as likely to be carefree.

Table 39 Rate of Gender Participation in Entrepreneurship

Author	Year	Country	Male/female Ratio
Crant	1996	USA	2.40
US SBA	2001	USA	2x
Reynolds et al.	2001	29 countries	>3x
Reynolds, Carter, Gartner, Greene, & Cox	2002	USA	2x
Bergmann, Japsen and Tamasy	2002	Germany	2.13
Sternberg and Bergmann	2003	Germany	2.07
Welter and Lagemann	2003	Germany	2.15
Minniti and Arenius	2003		>2x
LauxenUlbrich and Leicht	2003	Germany	2.01
Reynolds et al.	2004	GEM member countries	2x
Acs et al	2005	GEM member countries	2x
Wagner	2007	Western Industrialized cys	>2x
Allen et al.	2007	Germany	2.23
Monica Lindgren and Johann Packendorf	2010	Estonia, Finland and Sweden	2x
Mitchell	2011	USA	2x
Fairlie R and Marion J.	2012	USA	2x
Ding, Murray and Stuart	2013	USA	2x
Piacentini	2013	OECD	3x
Koellinger et al.	2013	17 Countries	2x
Marina Furdas, Karsten Kohn	2013	Germany	3x
McCracken et al.	2015	Italy	2x

It needs consideration though, some studies are also critical of women's belief in their own capabilities. A Global Entrepreneurship Monitor study (2009) showed that less than half (47.7%) of women believe they are capable of starting a business, while well over half, (62.1%) of men believe they are capable. That lack of confidence persists through all economies and cultures studied. Later report by the same on Ireland also claimed the same. It showed that men were more confident that they had the necessary skills and knowledge to start a business (57 percent) than

women (42 per cent). Similarly, a higher proportion of women (43 per cent) than men (34 per cent) reported that fear of failure would prevent them from starting a business (GEM, 2010).

Others view the lower participation of women from a totally different angle. They argue that the greater feel for responsibility towards family and children make females less keen for setting up a business and perusing expansion related goals (Brush, 1992; Beaver, 2002). As a result women tend to set up businesses in sectors that are already traditionally woman- dominated such as health care, personal services, beauty, cleaning. To this end, woman entrepreneurs are considered to have a lower opportunity motive than male entrepreneurs.

In this regard, Reynolds et al (2004) examined the type of entrepreneurial act men and women engaged and he found that among people who involved in starting a new business, 77.9 percent of men chose entrepreneurship in order to exploit an opportunity against 71.4 percent of women. They further showed that 19.4 percent of men choose entrepreneurship out of necessity against 24.8 percent of women. Thus, though more females join entrepreneurship to exploit an entrepreneurial opportunity, they are more necessity based entrepreneurs than males. Hence, the overall increase in female entrepreneurship in a country does not fully imply improvement in living standards for those women.

**Hypothesis 1: Female are less likely to start an opportunity driven entrepreneurship than male**

### 1.2.2. Age

A large body of empirical research (for example Lin et al., 2000; Reynolds et al, 2002; Shane, 2003; Henley, 2005) suggests that the effect of age on the probability of engaging in some form of entrepreneurship follows non-linear relationship trend.

Real life also shows the existence of a bulk of entrepreneurs from all productive age groups of the population: Facebook (20), Microsoft (20), Apple (21), Google (25), Twitter (30), Amazon (30), Tesla (34), Oracle (35), Netflix (37), Zynga (41), Walmart (44) and McDonald (53).

Indeed, as often expected, age gives an individual a huge opportunity to advance the necessary skills, knowledge, connections and better financial position to starting business. In this sense, age is considered as quite a big addition to leverage entrepreneurial opportunities. It is also well documented that because entrepreneurial act generates additional income for retired people, save

the professional and industrial experience, know-how, financial means and assets that can serve as collateral, aged people shall tend to start business (Kibler et al., 2012; Walker and Webster, 2007). But age might also have a reverse effect on entrepreneurial work. At least two lines of argumentation explain the reverse effect of aging on entrepreneurial act.

The first argumentation suggest that the long service and seniority old people have in a company draw a huge wage advantage than their young counterparts. As a result they are afraid to risk the higher wage for risky and uncertain entrepreneurial work. Needless to say, the opportunity cost of starting a business rises as income of an individual increases.

The second argumentation on the other hand is based on the idea that old people do not have such a long time horizon to reap streams of future payments from starting a business. This diminishes their motivation to bear the risk and uncertainty associated with venture formation.

In fact, some like Kibler et al. (2012) claimed that many older people spent most of their lives working in paid employment and may not even be aware of the opportunities that self-employment can provide nor the steps involved in starting a business. In this regard they face very serious challenges accessing and gaining sufficient information relevant to business formation.

A significant amount of research fully confirmed a curvilinear or inverted U-shaped relationship between age and the propensity to leveraging entrepreneurial opportunity; first rises, reaches maximum and then falls (Henley, 2005; Parker, 2004; Reynolds et al, 2002; Lin et al, 2000; Taylor, 1996; Alba-Ramirez, 1994; Boyd, 1990; Borjas and Bronars, 1989; Rees and Shah, 1986).

In addition, the anatomy of the studies suggest a peak age for entry into entrepreneurship. They reported that entrepreneurship is concentrated more among individuals between the age of 25 and 44.

As outlined above, this has something to do with the skills and knowledge individuals accumulate through time. Obviously, the very young do not have stock of sufficient human capital to deal with entrepreneurial act while the very old have lost their creativity or lack the motivation to do so.

Furthermore, for the basic fact that older people have somewhat better experience than young people, they may be more likely to perceive an opportunity and act on this opportunity by starting a business, i.e. they engage more in opportunity-based entrepreneurship versus necessity-based entrepreneurship.

**Hypothesis 2: Older people are more likely to engage in opportunity-based entrepreneurship**

### 1.2.3. Education Level

As matter of fact entrepreneurial activity pertains to the courage, confidence, determination, knowledge, skills and the contact an individual has acquired before. Right entrepreneurial knowledge and skills undeniably provide an individual a superior advantage to exploiting entrepreneurial opportunities than those who don't have the same.

Education-entrepreneurship relationship literature shows that three basic areas have taken the center stage of entrepreneurship research.

The first focuses on the status of education relative to the general public. The second area sets to address the question do people with higher levels of education start more firms than people with less education? And finally, does education bring an entrepreneurial success?

When assessed in light of the three areas the relationship between the level of education and the chance to engage in entrepreneurial act felt short of clear. It is inconclusive and cannot really be a priory determined. In this regard, a theoretical contribution by Lazear (2002, 2004) suggests that entrepreneurs are "jacks of all trades" rather than specialized experts alike generally found in wage and salary work.

In some cases we found better educated individuals well associated with entrepreneurial act while in other situations less educated individuals are found to be more entrepreneurial.

Anecdotal evidence, inconclusive though, witnesses that it has long become a fact of life seeing a great deal of self-made billionaire entrepreneurs who bypass formal education, dropped out of high school or university: Elizabeth Holmes (Theranos), Bill Gates (Microsoft), Michael Dell (Dell), David Geffen (Geffen Records), Steve Jobs (Apple), Richard Branson (Virgin), Ralph Lauren (Ralph Lauren), Mark Zuckerberg (Facebook), Matt Mullenweg (WordPress), Arash Ferdowsi (DropBox).

On the other end of the spectrum, there also exists a great deal of companies founded by college grads (some even with masters and doctoral degrees) such as John Warnock and Charles Geschke (Adobe), Sandy Lerner and Leonard Bosack (Cisco), Bill Joy (Sun), Larry Page (Google), Gordon Moore and Robert Noyce (Intel), Jerry Yang (Yahoo).

The indistinct link between education and entrepreneurship suggested by these anecdotes is in fact confirmed by empirical research on the determinants of entrepreneurship, which does not find conclusive evidence on the effect of education on business ownership. For instance, a study by Johansson (2000) in Finland reveals less educated individuals are more likely to become

entrepreneurs while, in a sample of Swedes data, Honig and Davidsson (2003), and Delmar and Davidson (2000) both found that people who perceived entrepreneurial opportunities and engaged in entrepreneurial activity were the better educated ones. Parallel with the latter, Peter and Edwin (1994) found that Self-employed have more years of formal education than those who do not work for themselves. They noted that years of education for self-employed being 14.57 years against 13.58 years for wage and salaried employees.

Overview of previous research suggest a U-Shape relationship between level of education and entrepreneurship. People with low or high levels of education are more likely to be entrepreneurs than people with intermediate levels of education. This holds across data sources, time periods, and countries. For instance, using 1980 census Borjas and Bronars (1989) found that the entrepreneurial rates for less than high school, high school, less than college and college were 4.8, 4.2, 4.6 and 6.5 respectively. Similarly, Lin et al (2000), using Canada 1994 data, showed that entrepreneurial rates for elementary, less than high school, high school, less than college, college, and advanced degrees were 18.4, 13.5, 11.4, 10.1, 11.1, and 13.2 respectively. Later, using Danish data 1980-1996, Schjerning and Le Maire (2007) found that entrepreneurial rates for elementary, high school, less than college, college, and advanced degrees were 10.9, 10.9, 7.4, 3.6, and 12.9 respectively.

We viewed the education-entrepreneurship paradox from different perspectives.

#### **First, Positive relationship between entrepreneurship and low level of education**

The positive relationship between entrepreneurship and low education level lends itself to the unemployment history people have had in the labor market. As a matter of fact, people with low level of education always face so rocky road ahead over finding a paid job. They lack job related skills and experience to join the competitive job market. Hence, the lack of other possibilities in the labor market propels them to self-employment; surrogate entrepreneurship. This is in fact endemic in the literature (Evans and Leighton, 1990; Reynolds et al, 2003; Wagner, 2005; Anthony et al., 2011; OECD, 2011; OECD, 2012).

Across OECD countries, on average, 84% of the population with tertiary education is employed against just over 74% for people with upper secondary and postsecondary non-tertiary education and to just above 56% for those without an upper secondary education (OECD, 2011).

#### **Second, Negative relation between entrepreneurship and highly educated ones**

The negative relationship between higher education attendees and entrepreneurship can be explained by the fact that because of the skills and knowledge they acquired, they are of a better chance to engage in a more lucrative wage employment under better working conditions. This decreases the likelihood of entrepreneurship as the preferred career choice.

A large literature has emerged in recent decades on the impact of education on pay in wage employment. For example, a study in 14 OECD countries showed that the typical tertiary-educated employee on average earned 56% more than the typical employee with an upper secondary or post-secondary, non-tertiary education (OECD,2012). Similarly, a 2002 US Census Bureau study estimated that in 1999, the average lifetime earnings of a Bachelor's degree holder was \$2.7 million (2009 dollars), 75 percent more than that earned by high school graduates in 1999 (Anthony et al., 2011). Harmon et al. (2003) noted that an added year of education increases wage income by on average 6.5 per cent, based on a meta-analysis of micro level studies of wage earners.

In this context, it could then be argued that lack of paid employment jobs pushes people more to engage in entrepreneurship. The opportunity cost of starting a venture for an unemployed person is unsurprisingly low. They lose nothing by engaging in business. It is a question of making a living and sustaining life. Therefore, entrepreneurship, though not the only choice, is at the center stage to eke out a living for them.

Study in Germany by Wagner (2005) confirms this fact. He particularly argued that necessity entrepreneurs had a far more unemployment history than nascent opportunity entrepreneurs. Likewise, Reynolds et al (2003) found that out of those who had been engaging in start-ups with little education about 50 percent were categorized as necessity entrepreneurs, while for those with post-secondary education (or higher) less than 25 percent started a business out of necessity.

It also implies that people who have a lower level of education are more likely to become entrepreneurs out of necessity, whereas people who have a higher level of education are more likely to become entrepreneurs because of a perceived business opportunity.

Hence, the relationship between education and entrepreneurship could basically depend on the unemployment history an individual has in the labor market. This is clearly reflected in the type of entrepreneurship activity an individual is engaged in. As noted above, low educated people who are highly likely to be unemployed in the competitive job market joins necessity entrepreneurship while those who have a better education background in turn have a better opportunity to join the labor market are more likely to engage in opportunity entrepreneurship. The opportunity cost of engaging



in entrepreneurship for high educated people is fundamentally higher due to the higher wage they must forgo. In view of this, they much more engage themselves in lucrative and growing businesses.

Thus, we suggest:

**Hypothesis 3: People with low level of education are more likely to become entrepreneurs out of necessity, or**

**People with higher level of education are more likely to become entrepreneurs because of a perceived business opportunity**

#### 1.2.4. Working Status

The work status is described “in terms of whether the individual plays an active versus passive role in the labor market” (Arenius and Clercq, 2005).

Our assessment of the relationship between working status and the rate of entrepreneurial act unveiled that people who have been participating in the work force are more likely to engage in entrepreneurship than those who had passive role in the labor market (Mesch and Czamanski, 1997; Vesalainen and Pihkala, 1999; Shane and Khurana, 2001; Hoing and Davidsson, 2000; Delmer and Davidsson, 2000; Acs et al., 2005).

The argument was that people who had been in the work force could easily build networks, acquire the various stocks of knowledge and skills required of an individual for the formulation of an organized and effective entrepreneurial strategy. People who are outside the working system do not have such an opportunity. As a result people that are participating in the workforce evidently has what it takes to be an entrepreneur than those who are not in the work force.

In this regard, Acs et al (2005) found that that 81% of entrepreneurs in high income countries, 91% of entrepreneurs in middle income countries, and 77% of entrepreneurs in low income countries had jobs. In their survey of immigrants to Israel from the former Soviet Union, Mesch and Czamanski (1997) found that intentions to start business were 7.8 times higher for those immigrants with prior business experience than those without experience. Vesalainen and Pihkala (1999) surveyed a random sample of 2899 people in 16 municipalities in Sweden to know about the probability that they would start a venture in the next year. They found that the amount of prior experience was positively correlated with the intention to start new firms. Similarly, using a sample of 452 Swedes, Hoing and Davidsson (2000) and Delmer and Davidsson (2000) found that people who had founded a business had more years of managerial experience than the control group. Shane

and Khurana (2001) also claimed that labor market experience plays a great role to reduce the uncertainty about the value to be gained from exploiting an entrepreneurial opportunity and increases the entrepreneur's expected profit.

**Hypothesis 4: People with a better work experience are more likely to become an opportunity-driven entrepreneur compared to people with less work experience.**

#### 1.2.5. Income Status

Research on the relationship between income status and entrepreneurship suggest that entrepreneurial act is associated with Income (Evans and Jovanovic, 1989; Holtz-Eakin et al. 1994; Blanchflower and Oswald 1998, Roberts and Robinson, 2010; Hessels et al; 2008; Acs, 2007; van Stel et al, 2007).

We demonstrate the association by elucidating the relationship between the amount of personal wealth an individual has and the additional loan requests for the startup. **Ceteris paribus**, wealthy people can comfortably present the collateral required of them to get loan request compared to people in the lower wealth distribution to secure a relatively larger amount of wealth. Hence, they have a better chance of securing additional loan from external sources. This is a big boost to engage in startups that will be otherwise impossible without the loan. Obviously, initial capital, the amount aside, is one of the necessary inputs for a startup to get a foothold.

The canonical model to conceptualize this relationship between individual wealth and entrepreneurship was developed by Evans and Jovanovic (1989). In their model, they basically demonstrated that the amount of wealth an individual can borrow to fund a new venture is a function of the collateral he or she can post, which in turn is a function of personal wealth. In fact, personal wealth accumulation may be endogenous. That is, if individuals with high ability are more likely to generate savings (because they earn more in wage employment relative to the mean person) and are also more likely to become entrepreneurs, the observed correlation between personal wealth and entrepreneurship may reflect this unobserved attribute rather than the causal effect of financing constraints (Holtz-Eakin et al. 1994; Blanchflower and Oswald 1998).

But despite the income factor, it is not unusual, however, to observe people with a lower capital start a new firm much better than people with a higher one. Truth to be told, as long as there are unemployed people with no chance of wage employment, entrepreneurship obviously serves as the only and best option to make a living for them. Low income individuals, as expected, tended to

pursue out of necessity or survival entrepreneurship: necessity entrepreneurs. This, on the other hand, infers people who are from the high income spectrum quite often engage in entrepreneurial act to exploit perceived business opportunity: opportunity entrepreneurs. That is, as explained well by Roberts and Robinson (2010), and Hessels et al (2008) for the rich entrepreneurship is a deliberate personal choice intended to make profit; the nature of the profit differs though. By contrast, necessity entrepreneurs are much more common in economies with limited employment opportunities and weak social safety nets catering for basic needs of people (Acs, 2007; van Stel et al, 2007).

### **Hypothesis 5: Low income people start a business out of necessity**

#### 1.2.6. Self-Assessed Business Skills

Research on the relationship between self-assessed business skills and entrepreneurship indicates that entrepreneurship is not everyone's cup of tea. Rather its working pertains to confidence in the skills and capabilities an individual perceives to possess to accomplish a behavior (Zietsma 1999, Hull et al, 1980; Malebana and Swanepoel, 2014). Someone with all the requisites to start a firm but self-confidence can't get the courage to go ahead with starting a firm and seeing firm creation through to fruition. Lack of self-confidence reasonably stifles entrepreneurial work. High successful entrepreneurs always have little self-doubt in their abilities to effectively perform various roles and tasks associated with entrepreneurship. They believe they have what it takes to be a successful entrepreneur.

We argued that self-confidence is a stepping stone and a basic antecedent to change an idea contemplating in one's mind to real. People who feel capable of starting a firm are more prone to do so than those who do not feel the same. It triggers entrepreneurial intention.

A substantial body of empirical studies upholds the same. In their study, Malebana and Swanepoel (2014) on a sample of 355 final-year commerce students from two South African universities showed that self-confidence had a telling effect on entrepreneurial act. Similarly, a study on the nature of 78 investors by Baron and Markman (1999) found that those who had started firms scored higher on a self-efficacy scale-belief in one's own ability to perform a given task- than those who did not start firms. Business owners scored highly on a self-esteem scale than managers in Robinson et al (1991) study. Hull et al (1980) found that alumni of the university of Oregon who were business owners scored more highly on an entrepreneurial task preference scale than non-owners. Zietsma

(1999) assessed 52 technology firm founders with 22 senior technology managers who had considered exploiting entrepreneurial opportunities but decided against their pursuit. She found that non-founders were significantly less likely to be confident in themselves and their team than the firm founders were.

**Hypothesis 6: People who have a higher self-assessed business skills are more likely to start a new business.**

### 1.2.7. Social Ties

We develop our review based on Bandura's Social Learning Theory (SLT). It claims that an individual can learn vicariously through observing people around (Bandura, 1971).

The extent to which an individual interacts with people who works on business is of imperative importance for new and emerging businesses. The central tenet of social ties with entrepreneurial people is like priming the conduit through which information flows to bring about entrepreneurial behavior. Entrepreneurs take advantage of the contact with relevant stakeholders such as parents, friends, teachers, mentors, partners, suppliers and customers to establish a business, as well as to locate others with experience and knowledge. They use their network as a source of information and support, and as a means for clarifying and evaluating their options. Through social network individuals can learn how things can be done, where resources can be located, or of factors leading to success and failure. The transaction cost to start a firm thus becomes low and encouraging.

In this regard, Davidsson and Hoing (2003) and Arenius and Minniti (2005) claimed that individuals who are familiar with the entrepreneurial community have a higher probability of becoming an entrepreneur. Having an entrepreneurial parent could be taken as a big example hereof. It increases the probability of their children to end up as an entrepreneur by a factor of 1.3 to 3.0 (Dunn and HoltzEakin 2000, Arum and Mueller 2004, Sørensen 2007, Colombier and Masclet 2008, Andersson and Hammarstedt, 2011).

Similarly, studying on female MBA graduates, Burt and Raider (2002) found higher rates of transition to self-employment among those with structurally diverse networks. In the same breath, Rezulli, Aldrich, and Moody (2000) demonstrated that would-be entrepreneurs with strong networks founded new firms with greater frequency. Aldrich and Zimmer (1986) studied ethnic group self-employment in three cities in England and found that the majority of the owners obtained information about entrepreneurship through social channel. Out of 82 firms surveyed by Koller (1988), 46 of them revealed that they had got a business idea from a business associate, relative, or

other process. In addition, in an in-depth qualitative study of seven entrepreneurs in rural Scotland, Jack and Anderson (2002) found that the embedding of the entrepreneurs in the social context in which they lived was what enabled the entrepreneurs to identify entrepreneurial opportunities. Hence, strong ties or ties to people that one trusts fasten venture starting process for they provide information that the recipients believe to be accurate as Shane (2003) has explained. That is getting the right business information is a crux to know the flaws in the very nature of business ideas and reduce uncertainties related with entrepreneurship. It would also influence an individual's performance at an entrepreneurial activity because the performance of new ventures depends on obtaining resources and information from others, and obtaining these staff depends on social interactions. As a result entrepreneurs with broader and more diverse social networks should have better access to financial resources, develop stronger ties to customers and suppliers, obtain more accurate information, and hire people with better skills than other entrepreneurs (Bruderl and Preisendorfer, 1998). Consequently, their venture perform better. Empirical research support this argument. Shane and Stuart (2002) examined the life histories of 134 new companies and founded to exploit intellectual property assigned to the Massachusetts Institute of Technology from 1980 to 1996, and found that entrepreneurs who had indirect ties to investors before starting their firms had ventures with a lower likelihood of failure than did the ventures of other entrepreneurs.

The entrepreneur's social ties also appear to enhance other measures of new venture performance such as profitability of the firm. Aldrich, Rosen and Woodward (1987) found positive correlation between the interconnectivity of entrepreneurs' social networks and their ventures' profitability. As a matter of fact people with more social networks can sale their products at the lowest possible transaction cost. Because of the channel they establish, they can easily reach users of their output. In this regard, Hoing and Davidsson (2000) found that entrepreneurs who were members of a business network had ventures with a significantly higher probability of achieving first sales than did entrepreneurs who were not members of a business network. Lee and Tsang (2001) examined the rate of growth of sales of 168 founder- run new ventures in China and found that frequency of external communication had a positive effect on the rate of venture sales growth.

**Hypothesis 7: People who have strong social ties are more likely to realize opportunities and start a new business.**

### 1.2.8. Fear of Failure

Prior to an entrepreneurial output, exactly knowing the right output that meets consumers' needs and generates profit is almost impossible. This is partly ascribed to the fact that information about the future is quite unpredictable and asymmetric. It is not easy to know the exact type and amount of resources that will be required to produce a given output. The production process and the time required to produce the product are also difficult to tell.

Entrepreneurship also has market risk as it is difficult to forecast the number of customers and the product price or even the pace people will exactly adapt to the product. Once again, it has competitive risk because they do not know the speed at which the new products or services will be imitated and their profits eroded, or how their profits will be affected by the complex interdependence of actions by multiple competitors. Therefore, when entrepreneurs exploit opportunities, they are bearing risks that cannot be insured or otherwise avoided (Amit et al., 1993). The uncertainty situation in the entrepreneurship playing ground thus scares many people to engage in entrepreneurship. It escalates the fear of failure among potential entrepreneurs and restrains them from starting business. Fear of failure naturally leads to higher risk perception and negative evaluation of entrepreneurial situation to exploit entrepreneurial opportunities (Welppe et al, 2012). Individuals who are afraid of failure tend toward a prevention focus instead of a focus on opportunities, which negatively influences decisions to take entrepreneurial activities (Bronckner et al, 2004; Higgins, 2005).

Empirical studies focusing on fear in entrepreneurial act also showed the same result. Kelley et al (2011) and Brixxy et al (2011) surveyed the fear among would be entrepreneurs and they found that fear of failure deters many potential entrepreneurs from founding a company.

There are also certain findings about the characteristics of the individuals who fear failure. For example, fear of failure has a strong effect on the women to refrain from founding a company than men. In Germany in 2011, 56% of women and 46% of men would refrain from founding a company, because of fear of failure (Brixxy et al, 2011).

**Hypothesis8: People with a higher fear of failure are less likely to start a new business**

## Chapter 2: Entrepreneurship and the Prevailing Business Environment

2.1 Introduction 2.2 Business Regulation 2.3 Lack of Finance 2.4 Poor Infrastructure 2.5 Entrepreneurial Knowledge and Skills 2.6. Market Size

### 2.1. Introduction

The entrepreneurship literature has periodically investigated that the ability of entrepreneurs to thrive in today's dynamic economic system is a reflection of a number of varied multidimensional challenges, be it economic, technological, demographic, cultural or/and institutional factors. Of interest in this part of the dissertation is in fact the impact of the prevailing business environment on the workings of entrepreneurship that essentially attempts to explain laws and regulations along with finance, infrastructure, entrepreneurship education and market size.

### 2.2. Business Regulation

Extant literature on the effect of regulation on entrepreneurial act evidenced that effective and efficient regulations give entrepreneurs a rather better chance of thriving at the lowest possible cost. Fast, over-simplified and dynamic business regulations are of great importance to unleashing the entrepreneurship potential of a nation.

In this regard, the 10<sup>th</sup> edition of Doing Business report specifically takes stock of the extent countries come in business regulatory practices and the challenges remain. It specifically noted that regulations are like traffic lights put up to prevent gridlock. Alike efficient traffic rules in a city, smart business regulations are essential to allow business transactions flow right and smoothly.

Tougher and complicated business regulations wreak havoc on entrepreneurial acts. They soar the time and cost needed to start a business, making it less likely to take root. Costly regulations impede the setting up of businesses and stand in the way of economic growth (De Soto, 1990; Djankov et al., 2002; World Bank, 2004).

In an industry-level study covering 98 countries, Alfaro and Charlton (2006) claimed that the higher number of days required to start a new business had a telling effect to obstruct new firm formation. They also argued that worse bureaucratic quality has a deterring effect on the workings of a new firm.

Based on industries that had many new firms entering the market, Klapper, Laeven and Rajan (2006) found that entry regulations such as time, cost and number of procedures associated with

starting a new firm were associated with a decrease in the number of start-ups, in particular small start-ups. Similarly, Desai, Gompers and Lerner (2003) showed that entry regulation in terms of the number of procedures required to start a new firm is negatively correlated to new firm formation. Looking specifically at industries with fast technological change and growing global demand, Ciccone and Papaioannou (2006) indicated that the longer a firm has to spend starting a business the lower the number of firm starting in these industries.

Researchers such as Djankov et al. (2002) argued that the existence of high entry cost further shows the prevalence of higher corruption and larger unofficial economies that in turn stifles firm growth. In this regard, Fisman and Svensson (2007) tried to analyze the constraining effect of bribes on the performance and growth of a firm and found that a 1 percentage point increase in bribes reduces annual firm growth by three percentage points.

In addition, lack of rule of law and property rights led entrepreneurs to engage in bribery to facilitate their entrepreneurial ventures. Hence, as illegal activities are costly to entrepreneurs, both financially and morally (Fadahunsi and Rosa, 2002), they opt to undertake productive entrepreneurship when that form of entrepreneurship is supported. In a panel data study, Nyström (2008), found a positive relationship between regulatory quality and entrepreneurship, using self-employment as a measure of entrepreneurship.

Strong property rights enhance the realization and exploitation of entrepreneurial opportunity for several reasons.

First, rule of law, a key component of strong property rights, increases freedom from coercion. It boosts the confidence that people can reap the results of their entrepreneurial work. That is, under strong property rights, people believe that any entrepreneurial profit that they earn will not be taken away from them arbitrarily, facilitating opportunity exploitation (Harper, 1997).

Second, rule of law makes the legal framework stable, allowing entrepreneurs to make plans to exploit perceived opportunities with a reasonable degree of confidence that the rules of the game will be the same in the future as in the past (Harper, 1997).

Third, rule of law expedites the coordination and management of resources in transactions that occur at different points in time through increasing the confidence that those who provide them with access to resources have legitimate rights to them (Harper, 1997).

Fourth, rule of law creates room for a better division of labor and specialization by easing enforcement of contracts. As a result, entrepreneurs can manage obtaining the financial and human



resources from external parties, and do not have to internalize the entire value chain to exploit opportunities. These characteristics encourage opportunity exploitation at the margin by people whose opportunities are best exploited through contractual organization arrangements, and who need to obtain capital and labor from external sources (Libecap, 1993).

Fifth, rule of law enhances innovation by facilitating the appropriation of the returns to the same (Casson, 1995).

We also argue that tax regulation is also found at the center of pursuing entrepreneurial opportunity. Indeed, an unproportioned marginal tax rate levied on entrepreneurs discourages them from opportunity exploitation. In this aspect, Fisman and Svensson (2007) found that a one percentage point increase in taxes reduces annual firm growth by one percentage point.

The constraining effect of marginal tax rates can be explained from two perspectives.

First, higher marginal tax rates make people less willing to accept variable earnings, thus decreasing the likelihood of self-employment (Hubbard, 1998). Second, high marginal tax rates decrease people's intentions of the profitability of exploiting opportunities, thereby reducing the likelihood that they will act on the opportunities that they recognize (Harper, 1997). In this regard,

Gentry and Hubbard (2000) examined data from the panel study on Income Dynamics from 1979 to 1992, and found that the higher the marginal federal income tax rate was in the United States, the lower the rate of self-employment.

Another basic law that we need to consider in firm formation is bankruptcy regulation. It provides regulations during exit to manage debts; for the reduction or elimination of certain debts, and can provide a timeline for the repayment of non-dischargeable debts over time. It also allows firms to pay back secured debts often on more favorable terms to the borrower. In this case firms can exit the market quickly and increases an economy's ability to reallocate resources among competitive ends.

Effective bankruptcy legislation permits entrepreneurs and investors to define the cost of failure (i.e., money at risk), and confirms that all parties will receive the most for their investment should the enterprise fail. Excessive bankruptcy costs on the other hand raise the costs of entrepreneurial failure and lead potential entrepreneurs to shy away from risk-taking (OECD, 1998).

An element of bankruptcy legislation which can boost entrepreneurship is the discharge clause which applies to unlimited liability companies. But its implementation varies across countries. For instance, countries such as Australia, the United States and the United Kingdom offer the bankrupt

individual a “clean slate” by way of discharge: the entrepreneur loses assets to creditors but cannot be pursued for any remaining claims which have not been met. This approach allows considerable flexibility to reduce any stigma attached to business failure notwithstanding the fact that it somewhat makes bankruptcy more attractive to debtors with negligible assets.

In other countries, by contrast, legislation places more emphasis on creditor protection and, in some cases, the absence of discharge clauses means that failed entrepreneurs can be pursued for several years, a situation which is not conducive to risk-taking activity such as entrepreneurship (OECD, 1998).

Another element of bankruptcy legislation that can affect the entrepreneurial process is the reorganization option. As a matter of fact, most bankruptcies end in liquidation. On the positive side, this procedure is relatively quick. However, there is a risk that early liquidation will force the closure of firms, which are only temporarily insolvent but viable in the long term. As a result, countries enact re-organization procedures to protect potentially viable firms: a firm can apply for protection from its creditors while negotiations are carried out to decide the terms on which it can be reorganized if viable, or wound up if not. In this regard, Doing Business forwarded index that measures whether and how creditors vote on a reorganization plan and what protection are available to dissenting creditors (Doing Business, 2016).

### 2.3. Lack of Finance

To make entrepreneurship an evident, competitive, innovative and sustainable career option, entrepreneurs need adequate financial resources.

Despite the critical importance of finance to thriving entrepreneurship, access to finance has long been considered as an acute challenge that cripples a new firm and send it spiraling down. It highly makes the choice of becoming entrepreneur filled with hesitation and discourages firms from investing the optimal amount so that firm productivity, growth and survival are compromised (Dethier et al., 2011; Carreira & Silva 2010; Rijkers et al., 2010; Musso & Schiavo 2008; Parker & Van Praag, 2006). The studies noted that small loan amount, excessive collateral and cumbersome procedures to securing loans are critical aspects of the financial hurdle entrepreneurs raise in their business endeavor.

For example, Mambula (2002) found that 72 percent of entrepreneurs he studied in Nigeria considered lack of financial support as the number one constraint in developing their business. He

further noted that small businesses consider procedures for securing business loans from banks cumbersome, and the collateral demanded for such loans is quite excessive. McMillan and Woodruff (2002) overviewing many studies on entrepreneurial act in transition economies found that credit availability was an important factor that affected entrepreneurial activity in these economies.

In fact, lenders do not fully agree with the claim. For instance, banks defend their behavior by noting that most small firms that apply for loan do not present acceptable feasibility study or good business plan. They further argue that many entrepreneurs do not even have a deposit account in a bank, a condition for advancing a loan to an applicant. More serious is that, Mambula (2002) underscores, for example, in some African countries banks are required by law to set aside a certain percentage of their profits for small business loans but there is no law to protect a bank against loan default. As a result banks would rather pay a fine than make what they believe to be a high risk loan. Banks also point out that entrepreneurs are unwilling to acquire formal training in how to run a business. Obviously a person whom no one trusts cannot raise the capital required to be able to start a firm.

Related argument to the lack of finance is concerning the interest rates. As a matter of fact firm formation is more common when interest rates are lower. When the costs of capital are higher, the expected value of fewer opportunities will exceed the entrepreneurs' opportunity cost, liquidity premium and uncertainty premium, making them less likely to exploit opportunities. Many studies shed light on this argument. For instance, Baum et al (2000) examined the performance of 142 Canadian biotechnology firms founded between 1991 and 1996, and found that the amount of capital available in the biotechnology sector at founding and in the preceding year, had a positive effect on the new ventures' employment growth.

#### 2.4. Poor Infrastructure

Basic physical infrastructures such as good roads, sufficient power supply and transportation facilities are rather at the heart of a well-functioning and healthy economy. Most entrepreneurs, particularly in developing countries like Africa claimed the lack of well-shaped infrastructure facility thwarting the process of venture creation. Deplorable roads, deteriorating rail lines where rail transportation exists, inadequate power supply, and unusable waterways characterize the infrastructure spectrum. In fact, the combined effect of these facilities make small business operations just like a daydream. In this regard, Akwani (2007) elucidated that damage to equipment

because of power surges and downtime due to unavailability of electric power during production hours are major problems for small manufacturers in some African countries. Indeed, to overcome such a problem, entrepreneurs who can afford it, own private generators to power their manufacturing operations, thus increasing production costs and making their products less competitive. Furthermore, poor transportation facilities and bad roads result in higher cost of moving goods from one section of the country to another. For instance, Juma (2011) indicated the transport cost on clothing export in Uganda was equivalent to 80 percent tax on the item

Further evidence from developing countries also revealed that the information and communication infrastructure in most countries are very weak. Low level of internet usage characterizes them. They also face low telephone penetration, and inadequate broadcasting facilities, computing infrastructure, and other consumer electronics. Needless to say, access to information infrastructure is an indispensable condition for widespread socio-economic development (Cogburn and Adeya, 2000).

In fact infrastructure challenge has already been a productivity trap in many countries. For instance, infrastructure shortcomings—mainly in energy and transport—are estimated to account for about 30 percent of the productivity handicap faced by Kenyan firms (Escribano et al. 2009). Similarly, infrastructure constraints account for about 42 percent of the productivity gap faced by firms in Cameroon (Dominguez-Torres and Foster, 2011).

## 2.5. Entrepreneurial Knowledge and Skills

Stock of entrepreneurial knowledge and skills are fundamental for a promising entrepreneurial work. It basically helps to boost the self-confidence and self-efficacy of individuals to cope with the inevitable challenges [nascent] entrepreneurs face ahead. It also ensures entrepreneurs to develop a good project proposal and secure a great pool of finance required to start a viable firm, which in fact was a big challenge that lenders never get an answer to give loan for entrepreneurs. Prospective entrepreneurs need to be able to convince lenders that they have the viable proposition, the determination and tenacity to succeed.

The entrepreneur should be competent enough to demonstrate an intimate knowledge of his/ her business model, as well as the working environment of his/her firm. He/she needs to have the skills used to sell, bargain, lead, plan, make decisions, solve problems, organize and communicate (Shane, 2003). More specifically, in the words of Paul Harris, “the entrepreneur must know something

about everything and everything about something” (NIESBUD, 2013). As mentioned so far entrepreneurs need to be “Jacks of all trades”.

Entrepreneurship education is a critical policy tool in building the knowledge, skills, attitudes and behaviors required for entrepreneurship against the traditional education programs that prepare students for the conventional career.

Empirical research also sustain the remarkably high importance entrepreneurship education has to marshaling entrepreneurial growth. For instance, according to Premand et al (2012) entrepreneurship training participants were on average 46 to 87 per cent more likely to be self-employed compared with non-participants. Similarly, a survey by Jenner (2012) unveiled that students who participate in entrepreneurship training in their secondary school education will later start their own company three to five times more than the general population. In the same breath, Clark et al (1984) found that 76percent of non-business owners taking the “Your Future Business” course subsequently opened a business. Upton et al. (1995) found that 40 percent of those who attended entrepreneurship courses have started their own businesses, while 30 percent joined family businesses and only 30 percent worked for large organizations. Study by Hornaday and Vesper (1982) indicated that 66percent of students who took a course in entrepreneurship revealed that entrepreneurship has affected the direction of their career. An assessment of a UNDP entrepreneurship training program in Nepal aimed at boosting entrepreneurship among poor rural women indicated that more than 70 percent of the participants’ families moved out of poverty and about 80 percent of the enterprises started under the project continue to do business today.

The ILO tracer studies on the “Know About Business Entrepreneurship Education Program (KAB)” show also the positive effects of entrepreneurship trainings. According to the studies, in Peru, three out of four former KAB students responded that they intended to open a business compared to one out of four of the control group. One third of those interviewed said they had drawn up a business plan, compared to one out of four from the control group. Likewise, in China, a sample survey of former KAB participants found that over 90% of business owners rated it as useful or very useful for starting a business, while former KAB students had fewer objections to employment in a small business than non KAB students, indicating that the program had changed attitudes.

## 2.6. Market Size

Market size is also an important factor determining the status of entrepreneurship in an economy.

Big and growing markets give entrepreneurs the opportunity to easily leverage the excess demand that incumbent firms cannot meet. Big markets allow the fixed costs of organizing a firm to be amortized over more sales. Larger market size should reduce new firm failures by providing greater opportunity for scale economies. By exploiting scale economies, new ventures can reduce their average costs and therefore be more likely to survive (Shane, 2003).

Previous studies (Yasuhiro et al, 2012; Addario et al, 2010) support the proposition that growing markets enhances entrepreneurial activities. Using data on Japanese prefectures Yasuhiro et al (2012) parsed the effect of market size on entrepreneurship and found that a 10% increase in the population density increases the share of people who wish to become entrepreneurs by approximately 1%. A related study in Italy by Addario and Vuri (2010) indicated that larger market size has an inviting financial advantage for entrepreneurs. According to them each 100,000 inhabitant-increase in the size of the individual's province of work raises entrepreneurs' net monthly income by 0.2-0.3 percent.

In an examination of 98 semiconductor firms founded in the US between 1978 and 1985, Shane (2003) claimed that the size of the semiconductor market had a negative effect on new firm failure rates. Shane and Stuart's (2002) examination of the life histories of 134 new companies founded to exploit intellectual property assigned to the Massachusetts Institute of Technology from 1980 to 1996 showed that the size of the founding firm's industry increased its likelihood of initial public offering.

## Chapter 3: The Role of Entrepreneurship Education on the Intention towards Entrepreneurship

3.1 Introduction 3.1.1 Concept of Entrepreneurship Education 3.1.2 Assessment of Entrepreneurship Education Impact Studies, and Subsequent Research Gaps 3.2 Theoretical Framework and Research Hypotheses 3.2.1. Entrepreneurship Intention Theories 3.2.2. Intention Models 3.2.2.1 Entrepreneurial Event Model (EEM) 3.2.2.2. Entrepreneurial Intention Model (EIM) and Revised EIM 3.2.2.3 Theory of Planned Behavior(TPB) 3.2.3 Discussion and Selection of Theoretical Framework 3.2.4 Hypotheses 3.2.5. Summary of the Conceptual Model

### 3.1. Introduction

This chapter reviews and synthesizes extant literature that helps to build a theoretical base related to entrepreneurship education and intention to entrepreneurship. We used a wealth of journal articles published in leading academic journals specializing in the area of entrepreneurship, entrepreneurship education and entrepreneurial intention theories. This basically helps to acquire a strong theoretical framework to measure the development of attitude and intention to entrepreneurship. Accordingly, the relationship between entrepreneurship education and entrepreneurship intention is very well documented and intention theories summarized. A theoretical framework is chosen and hypotheses are developed.

#### 3.1.1. Concept of Entrepreneurship Education

*The reasonable man adapts himself to the world; the unreasonable one persists in trying to adapt the world to himself. Therefore, all progress depends on the unreasonable man.*

—George Bernard Shaw

According to Drucker (1998), as a discipline per se, innovation and entrepreneurial works are not magic or mysterious. They have nothing to do with genes; they require knowledge, skills and perceptions associated with the practice of entrepreneurship. They come through life experiences. As Kurato (2005) noted, an entrepreneurial perspective can easily be embedded in the minds of individuals. Entrepreneurship is a learned phenomenon. Effective entrepreneurship education

beyond and above inculcates entrepreneurship knowledge and skills required of a person to start an entrepreneurial firm.

The history of entrepreneurship education dated back to 1938. It is attributed to a Japanese teaching pioneer named Shigeru Fijii. He had initiated education in entrepreneurship at Kobe University, Japan (Alberti et al. 2004). But most entrepreneurship education programs were introduced in American Universities (Katz, 2003). American universities, as elucidated by Franke and Luthje (2004) and Raichaudhuri (2005), have a better tradition as entrepreneurship education providers in their business schools, and pave the way for entrepreneurship studies as a legitimate area of academic study. For instance, when the first entrepreneurship course in the United States was offered in February 1947, only 188 Harvard students were enrolled. But 50 years later, around 120,000 US students were participating in entrepreneurship courses (Katz, 2003). Following this surge in entrepreneurship education Katz once said:

*“Twenty years ago students who dared to say they wanted to start their own companies would be sent for counseling. Today entrepreneurship is the faster growing course on campuses nationwide”*

A concomitant rise in entrepreneurship courses and professions has also been observed all over the world (Loucks, 1988; SBA, 2000; Fayolle, 2000; Linán., 2004).

But, alike entrepreneurship, the literature review identifies there is still lack of consensus on what entrepreneurship education is all about in the academic literature. It has long been defined in rather various ways.

Gottlieb and Ross (1997) define entrepreneurship education in terms of “innovation” and “creativity” applied to governmental, business and social fields. Kourilsky (1995) stressed opportunity recognition, venture formation and marshalling of resources in risk-afflicted environments and situations as typical characteristics of entrepreneurship education. In his literature review study to define entrepreneurship education, Mwasalwiba’s (2010) identified attitudes, value, intentions and behavior(32%), personal skills(32%), new business(18%), opportunity recognition(9%) and managing existing firms(9%) as attributes included in it with increasing entrepreneurial spirit/ culture/ attitude (34%), start up and/ or job creation (27%), contribution to society(24%), and stimulate entrepreneurial skills(15%) as basic attributes of entrepreneurship education. In the same vein, Lewis (2002) defines entrepreneurship education as “development of



a group of qualities and competencies that enable individuals, organizations, communities to be flexible, creative and adaptable in the face of rapid social and economic change”. In this sense, the definitions present the inculcation of a range of skills and attributes, including the ability to think creatively, to work in teams, to manage risk and handle uncertainty (OECD, 2009) as fundamental components of entrepreneurship education. Thus, the notion of entrepreneurship education is to effectuating the development of a mindset that pertains to entrepreneurship and entrepreneurial behavior.

In the context of this dissertation, we defined entrepreneurship education as a pedagogical process about enabling people to develop the skills, knowledge and mindsets required of them to be entrepreneur.

The definition embraces a broader view of what it takes to be entrepreneurial. In this aspect, entrepreneurship education is a way of instructing people to creating the right mindset for an entrepreneurial act.

Entrepreneurship education programs thus target a wide range of objectives that can be

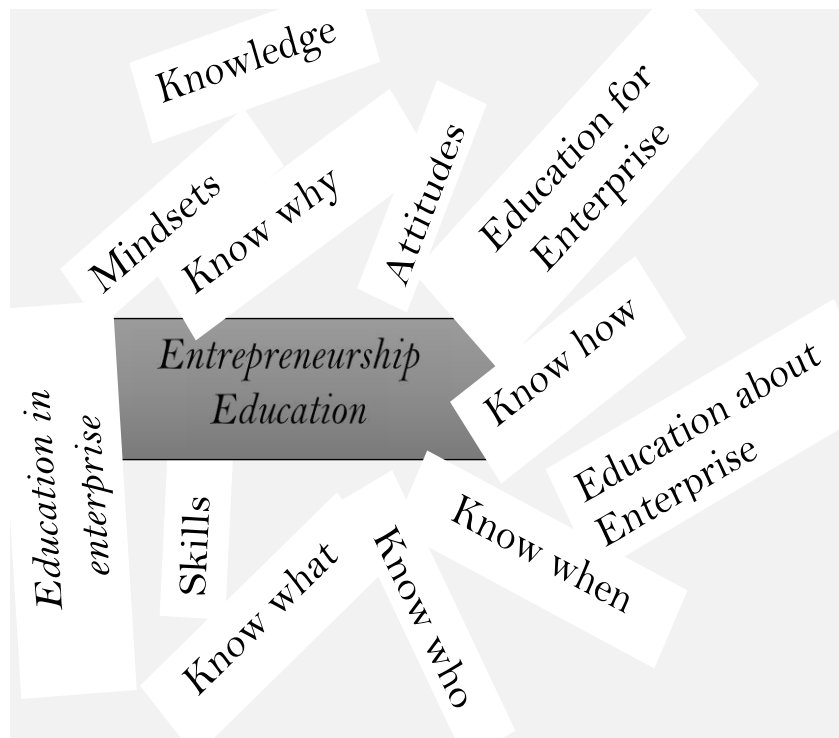

tracked. Academic research reveals a multitude of objectives across arrays of entrepreneurship education. It varies with the level of competence to achieve, the target groups and the objectives to fulfill. In some cases it aims to create entrepreneurs while in other instances it intends to make people think entrepreneurially in their work.

Interman (1992) detailed the objectives of entrepreneurship programs as entrepreneurship awareness, business creation, small business development, and training of trainers. Similarly, Jamieson (1984) suggested that entrepreneurship education provides three different classes of training such as education about enterprise (i.e., entrepreneurship awareness), education for enterprise (i.e., preparation of aspiring entrepreneurs for business creation) and education in

enterprise (i.e., training for the growth and development of established entrepreneurs). On the other hand, Johannisson(1991) posited that entrepreneurship education has five learning objectives in that participants of entrepreneurship programs will develop the know why (developing the right attitudes and motivation for start-up); know how (acquiring the technical abilities and skills needed to develop a business); know who (fostering networks and contacts for entrepreneurial ventures); know when (achieving the sharp intuition to act at the correct moment); and know what( attaining the knowledge base and information for new venture development) aspects of entrepreneurial training).

Recently, Linän (2004) developed four broader and comprehensive objectives of entrepreneurial training:

The first, “Entrepreneurial Awareness Education” aims at developing the entrepreneurial knowledge and skills of students that allow them determine their future career option. It ensures the students the skills required for a dynamic labor market situation that they are due to face in the future. It enables them acquire an insight in to the operation of a business afterwards. Thus, its target is the creation of more potential entrepreneurs in the future. It makes the students better aware that entrepreneurship is a rewarding and attractive career option. Most university-level entrepreneurship education programs fit very well to this category (Garavan & O’Cinneide, 1994; von Graevenitz and Weber, 2011; Lorz, 2011).

The second category is described as “Education for Start-Up”. These programs are meant to people who already have a viable business idea but not yet ready to take the plunge and risk failure. Hence this program primarily focuses on specific practical aspects related to the start-up phase purported to create unwavering stance of individuals towards venture creation. It focuses on how to obtain finance and deal with business regulations (Curran and Stanworth, 1989). Accordingly, it makes the participants to be nascent entrepreneurs either during or shortly after the course.

The third category, “Education for Entrepreneurial Dynamism”: apart from creating intention to become an entrepreneur, it geared towards people who are already entrepreneurs and want to promote dynamic behavior after the start-up phase. It provides the skills, knowledge and attitudes for entrepreneurs to stay competitive in the market.

The last category “Continuing Education for Entrepreneurs” relates to improvement of the existing entrepreneurial abilities and focuses on experienced entrepreneurs. It helps entrepreneurs to catch

up with the ever changing business environment. And enable them to become dynamic entrepreneurs. Thus, it is a sort of lifelong learning.

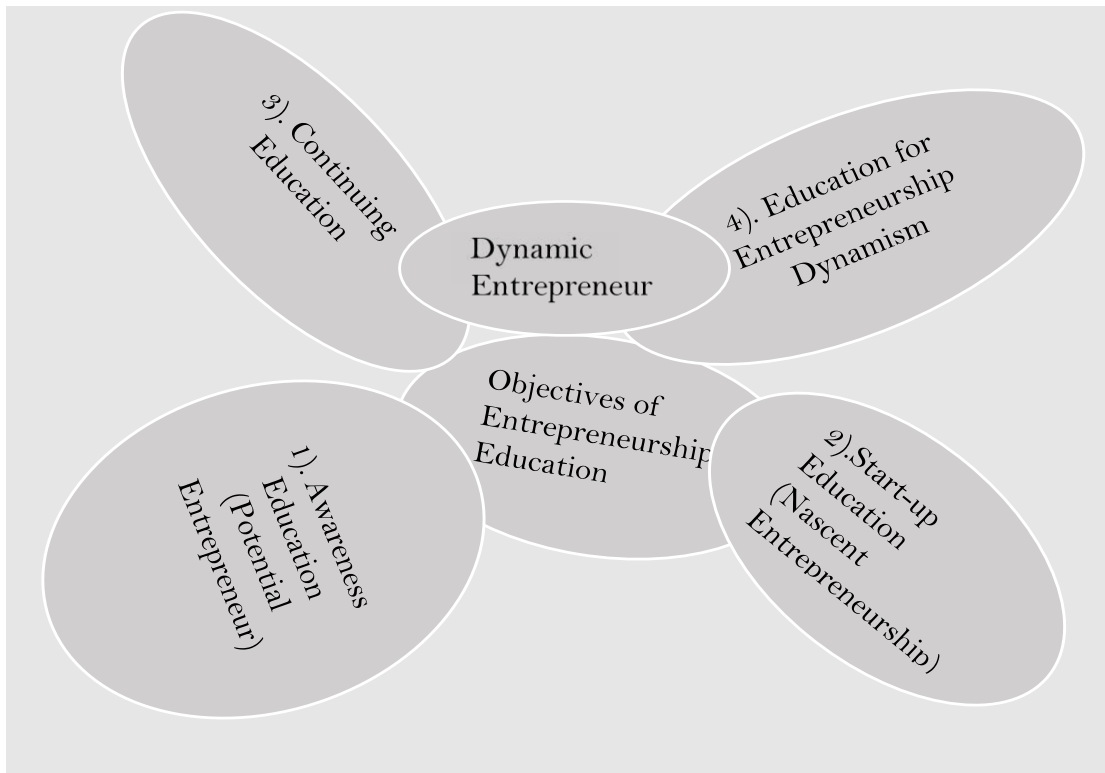

Figure 20 Objectives of Entrepreneurship Education

Along with the varieties of entrepreneurship education, four axes of research have retained the bulk of scholarly attention (Bechard & Gregoire, 2005). The first research stream focuses on the nature and structure of entrepreneurship education programs. The second research stream is concerned with the way entrepreneurial characteristics are imparted. It focuses on the exploration of the interactive dynamics between instructors and students. The third stream concentrates on investigations of the learning climate conducive to entrepreneurship and its teaching at the university level, and the fourth research stream measures the relative impact of entrepreneurship education on entrepreneurship.

This dissertation pertains to the fourth research stream that focuses on the analysis of the impact of an entrepreneurship program.

The next section discusses overview of previous studies about the effect of entrepreneurship education on the participants' entrepreneurial orientation.

### 3.1.2. Assessment of Entrepreneurship Education Impact Studies, and Subsequent Research Gaps

Along with the increasing number of entrepreneurship education programs at universities (Vesper and Gartner, 1997; Katz, 2003; Klandt, 2004), it looks true that various actors in the economy share the implicit premise that entrepreneurship education is quite critical to building the key entrepreneurial competencies and mindsets of individuals and push entrepreneurship to the social optimum level.

As a result, investment and innovation policies across countries has long been placing plethora of initiatives to promoting entrepreneurship education in the academic system. It is thus not uncommon, though not evenly, to observe entrepreneurship education courses, if not as a separate field of inquiry, in many universities all over the world. For instance, in 2007, Mozambique Ministry of Education and Culture has introduced the Entrepreneurship Curriculum Program (ECP) in secondary and vocational schools throughout the country to better prepare young people for entrepreneurial activities and trigger a nationwide, bottom-up economic growth process to reduce poverty. In 2014, Entrepreneurship Development Center Ethiopia has supported five public universities in setting up a Center of Excellence in Entrepreneurship that envisages to provide full-fledged entrepreneurship development supports, including incubation services, for their students, staff, and the community. The UK launched national entrepreneurship education strategies in 2004 (European Commission, 2012).

Against this backdrop, this section of the dissertation focuses on reviewing extant literature on the effectiveness of entrepreneurship education. Evaluation of its effectiveness greatly helps to put in place and effectuate future enterprise policy direction of a country. It also has an immense effect on pertinent curriculum review, design and development regarding entrepreneurship education.

Therefore, our guiding question for the review is, "Does entrepreneurship education really achieve its intended objective?"

Indeed, scholars have offered tremendous research insights into how entrepreneurship education impacts entrepreneurial thinking, new venture formation, growth and survival. In the extant literature, most research outputs reveal a significantly positive effect of entrepreneurship education

on the various proxies for entrepreneurship. It looks intuitive that entrepreneurship education is a key instrument to creating the requisites required of an individual to be a resilient and successful entrepreneur.

Amidst such a positive overall assessment, a comprehensive analysis of the impact studies, however, reveals that the effect of entrepreneurship education on entrepreneurial intention is not an unquestionable. The studies fail to give a clear direction to the relation between entrepreneurship education and the intention to entrepreneurship. The area is still infant, disputed and not well researched.

A review of an assortment of 57 studies on the impact of entrepreneurship education on the various proxies for entrepreneurship shows an overwhelmingly positive result; with 49 studies reporting a positive impact, 5 with mixed or insignificant result and the remaining 3 reporting negative result (table 40). But the apparent inconsistency and ambiguity among the researches spark reasonable questions on the methodological rigor of the studies. Taping out the underlying reasons for the discrepancy in the impact studies and identifying the research gaps in extant literature are, therefore, a matter of importance at this point of the dissertation.

To proceed with evaluating the impact studies we followed the criteria Storey (1999), Westhead et al (2001) and subsequent studies (Souitaris et al, 2007) recommended in designing an effective training evaluation.

They noted that effective training evaluations need to meet certain basic criteria such as a representative sample of participants, matched control groups, pre and post (program participation) testing, and then measurement of subjective as well as objective outcomes.

Basing on literature and criteria we developed, we prepared a synthesis matrix (table40) and then advance it to figure21 to relate entrepreneurship education and entrepreneurial act.

Table 40 Summary of Entrepreneurship Education Impact Studies

<b>Author</b>	<b>Year</b>	<b>Sample</b>	<b>Country</b>	<b>Control</b>	<b>Pre-post</b>	<b>Result</b>	<b>Focus</b>
Hattab	2014	182	EGY	✓	✗	P	M
Gerba	2012	156	ETH	✓	✗	P	M
Gibcus et al	2012	2582	9 EUR	✓	✗	p	B
Athayde	2009	196	ENG	✓	✗	P	B
Cheung	2008	128	HKG	✓	✗	P	M
Ghazali et al	2013	207	MYS	✓	✗	P	M
Getachew et al	2011	822	ETH	✓	✗	P	M
Hosseini et al	2010	90	IRN	✓	✗	P	Ag

Lee et al	2005	379	USA & KOR	✓	✗	p	B
Galloway et al	2002	2353	SCT	✓	✗	M	B
Kolveid et al.	1997	370	NOR	✓	✗	P	B
Charney et al	2000	511	USA	✓	✗	P	B
Souitaris et al	2007	250	ENG & FRA	✓	✓	P	E
Friedrich et al	2006	84	ZAF	✓	✓	P	M
Hansemark	1998	70	SWE	✓	✓	P	M
Kourilsky et al	1997	95	USA	✓	✓	P	M
Peterman et al	2003	236	AUS	✓	✓	P	B
Slavchev et al	2012	184	NZL	✓	✓	P	M
Van Praag	2012	2751	NLD	✓	✓	N	M
Oosterbeek et al	2010	562	NLD	✓	✓	N	B
Olomi et al.	2009	237	TZA	✓	✓	M	M
Küttim et al	2014	55781	17 EUR	✗	✗	P	M
Nasr et al	2014	-	TUN	✗	✗	P	B
Fatoki	2014	165	ZAF	✗	✗	P	B
Zhang et al	2013	494	CHN	✗	✗	P	M
Izquierdo et al	2011	236	ECU	✗	✗	P	M
Sánchez	2011	864	ESP	✗	✓	P	M
Byabashaija et al	2011	167	UGA	✗	✓	P	B
Bakotic & Kruzic	2010	176	HRV	✗	✗	P	B
Izedonmi et al	2010	237	NGA	✗	✗	P	M
Liñán,	2011	354	ESP	✗	✗	P	B
Cruz et al	2009	354	ESP	✗	✗	P	B
Jones et al	2008	50	POL	✗	✓	P	B
David	2014	300	ZWE	✗	✗	P	B
Matlay	2008	60	UK	✗	✗	P	M
Petridou et al	2008	104	GRC	✗	✗	P	M
Karimi et al	2012	320	IRN	✗	✓	M	M
Emmanuel et al	2012	206	NGA	✗	✗	P	M
Ekpoh et al	2011	500	NGA	✗	✗	P	B
Lepoutre	2010	2160	BEL	✗	✗	P	M
Von Graevenitz et	2010	196	DEU	✗	✓	N	B
Fayolle et al	2009	197	FRA	✗	✓	P	B
Fayolle et al	2006	275	FRA	✗	✓	M	B
Radu & Loué	2008	44	FRA	✗	✗	M	B
Harris & Gibson	2008	216	USA	✗	✗	P	B
Alarape	2007	62 firms	NGA	✗	✗	P	M
Wilson et al	2007	4292	USA	✗	✗	P	B
Chrisman et al	2005	159	USA	✗	✓	P	M
Galloway et al	2005	519	SCT	✗	✗	P	B
Zhao et al	2005	265	USA	✗	✗	P	B
Ohland et al	2004	159	USA	✗	✗	P	E
DeTienne et al	2004	130	USA	✗	✓	P	B
Wang and Wong	2004	5326	SGP	✗	✗	P	E

Wee	2004	65	SGP	✗	✓	P	E
Luthje et al	2003	512	USA	✗	✗	P	E
McMullan et al	2001	2samples	CAN	✗	✗	P	M
Chen et al.	1998	175	USA	✓	✗	P	B

✗ Represents sample without control or only ex-post analysis while  
 ✓ Represents sample with control or pre-post analysis; P represents positive result, N= negative and M signifies mixed result  
 B= studies that sample only business students while M is business and others and E represents studies that sample only engineering students.

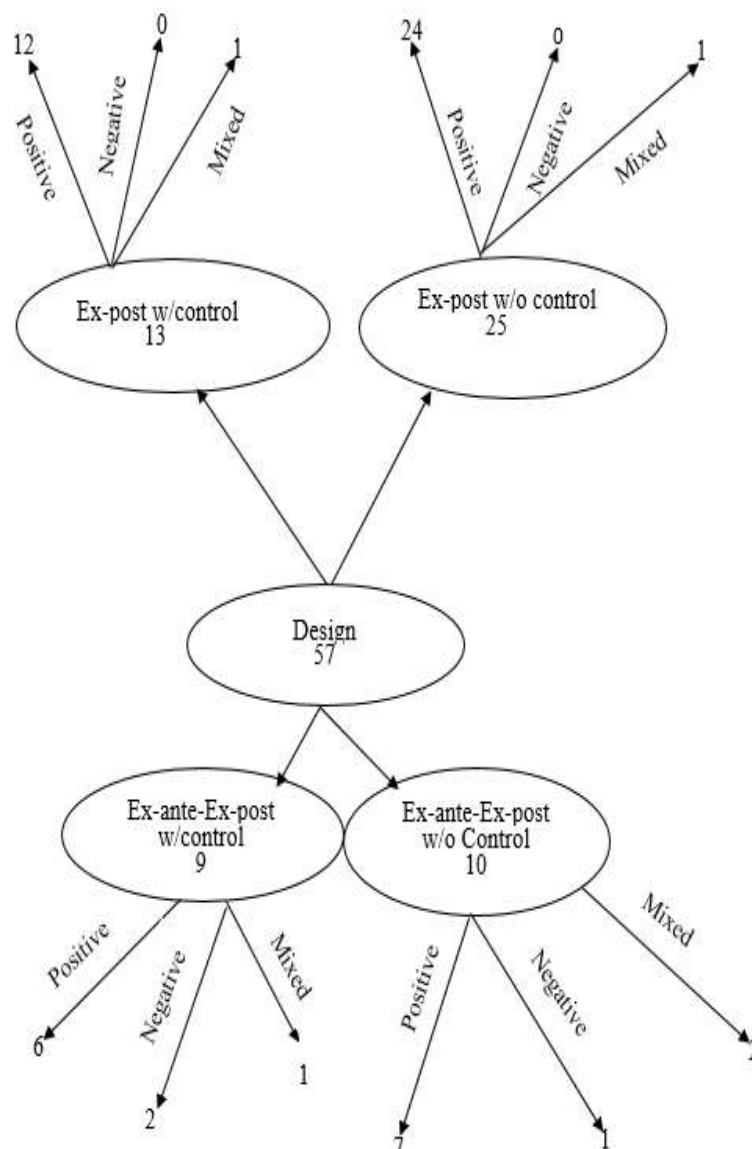

Figure 21 Summary of Entrepreneurship Education Impact Studies

We considered that the overwhelming majority of the studies lack the inclusion criteria required of a rigorous research method. They fail to include the basic procedural and methodological requisites that an effective impact study is supposed to embrace. This thus casts doubt on the real impact of entrepreneurship education. Despite the fact that we found all but positive association between entrepreneurship education with perception to entrepreneurship, most studies employed ex-post only analysis, lacked control groups or stochastic matching, and incorporated participants that already had some predilection to entrepreneurship prior to the training or course.

Out of the 57 studies, 38 of them tried to analyze the impact using sample only after the entrepreneurship education program was completed. All but 2 studies came up with the result that people who attended entrepreneurship education were tended to form a venture. The remaining two studies however indicated that the relationship between entrepreneurship education and perception to start a firm was mixed or not clear.

Despite the positive impact they show, we contend that ex-post only studies lack internal validity. We explain this from two perspectives such as self-selection bias and measurement time-lag.

Entrepreneurship education research usually assumes students enrolled in entrepreneurship courses are randomly selected. If the selection is not random, students who have already the predisposition to entrepreneurship are more likely to attend the program. And it shall not be surprising to realize that a study that examines two groups of students one entrepreneurship majors and the other non-entrepreneurship majors indicate a higher propensity to entrepreneurship to the former one. They have already had the basics how good would entrepreneurship be as an alternative job. Thus, it is not such an easy to reach the conclusion that the program makes the entrepreneurial group more entrepreneurial than the non-entrepreneurship group.

This is exactly what is happening to ex-post only method of assessment. It falls short of any baseline against which the progress of the participants can be measured, analyzed and compared within the course of the program. It lacks a proper analysis of a counterfactual of what the outcomes would have been in the absence of the intervention. Hence, it is much more difficult to offset the differences between the two groups before the course was offered to the students in the entrepreneurship group. In this method of analysis, it is ambiguous should the entrepreneur acquires the behavior prior to the entrepreneurship education or in the process of the program. We can't tell for sure that the behavior comes about of the intervention or some other factors and casts doubt on the relevance of the program.



Ex-post only studies also faced with measurement lag problems between the course and experiencing the impact of the program. It has long been observed that the number new firms entrepreneurship graduates start have been used as proxies for the impact of entrepreneurship education program. But what is actually happening on the ground is quite different. It is rare to see students own a firm soon after they finish the entrepreneurship education program or graduation. There is a huge gap between the time the graduates start a firm and the time they took the course. Literature on career transition show that academic entrepreneurs realize their business idea at about five years after graduation (Golla et al. 2006). The huge gap between the time the class was offered and the actual happening of the behavior poses a threat to internal validity and complicates longitudinal studies. In this case, it is not easy to observe and actually measure the effect of the program.

Thus, new firm creation only doesn't suffice and guarantee indicating the impact of the program. Start-up measures may exclude the measurement of key entrepreneurial competencies and mind sets of graduates. For instance, if a student who has taken entrepreneurship course sometime in the past is pushed to pursue business to eke out a living due to lack of any other employment opportunities, it is not easy to conclude the effect of the course on this basis. In regards, the evaluation of the effectiveness of entrepreneurship education may go beyond such start-up measure and emphasize on the latent effects (Block & Stump, 1992). For the fact that entrepreneurship is a planned behavior under the will of the individual, intention is the best predictor of entrepreneurial behavior (Krueger, 1993; Krueger et al., 2000; Luthje & Franke, 2003). Hence, measuring intention to entrepreneurship should be at the center of entrepreneurship education impact studies.

A great deal of research suggests that the effectiveness of entrepreneurship education is measured in terms of the predictors of entrepreneurship action, such as entrepreneurial attitudes and intentions (*Section 3:2*). To this end, ex-post only studies are not ostensibly enough to identify and quantify the exact impact of entrepreneurial education on the participants' intention to start a new firm.

The other problem with existing impact studies is that though previous researches employ pretest-posttest analysis, the majority of them do not utilize control groups to compare and validate the effects of the course or training. Perusal of the studies reveal that 1/3 of the studies (19 out of 57) employed pretest-posttest design. We considered however that 10 of the 19 studies (52.6%) failed to have control groups in their research design. In fact, the statistics for the whole sample was 35 out of the 57 studies (62%). Such studies however face difficulty observing, confirming and

validating the effect of the program without any comparable group. Without any comparable control group, it is difficult to tell exactly if the change comes from the program or some other exogenous influences. Conclusions drawn based on the results may be wrong and lead to wrong policy responses and misallocation of resources.

Small sample size is also the other caveat that previous impact studies faced drawing valid inferences from the sample results. This is more prevalent in studies that applied the quasi-experimental or pre-post analysis and control groups. Using the Maas and Hox's (2005) minimum sample criteria, of the 6 studies that revealed positive impact and applied pre-post analysis and control group, only two of them (Souitaris et al., 2007; Peterman et al, 2003) used an experimental group with more than 100 samples.

In addition to the lack of rigor in previous studies, the number of entrepreneurship education impact studies in least developed countries is quite few. Despite the surge in entrepreneurship education promoting policies, little is known about the impact of entrepreneurship education offered in these countries. Analysis of table 40 clearly shows that only 4 studies were from least developed countries. The greater portion of impact studies to a great extent focuses on entrepreneurship trainings, projects, programs and courses that took place in developed countries.

Finally, the assessment of the strands of previous studies also reveals that entrepreneurship impact studies precluded some basic and relevant fields of studies such as natural science and technology. Far lower research has been conducted on students in the fields of natural science and technology students. Previous studies overwhelmingly target business and related students as their sample of study. Of the 57 studies identified on the role of entrepreneurship education, only 4 of them sample engineering students. This is quite against the reality that current entrepreneurs are from business and related fields are scanty. Our observation of the background of entrepreneurs from different sources indicated that 71% of the 21<sup>st</sup> century top entrepreneurs are engaging themselves in the technology area (figure22). This triggers the need for further impact studies in the field of engineering.

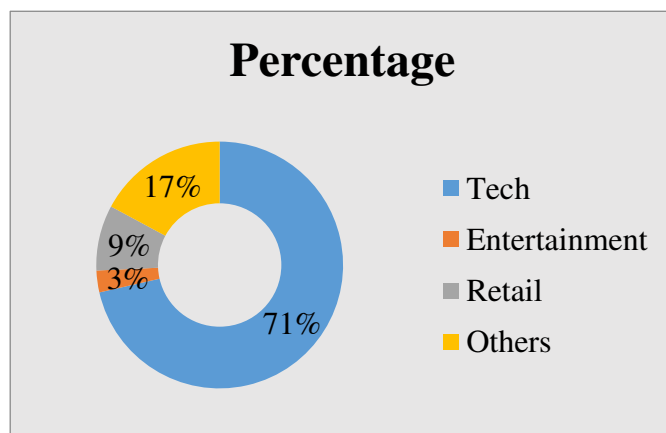

Figure 22 Sectors the 21st Century top Entrepreneurs engaged in

Grounding on the above analysis, the dissertation aims to fill the gaps identified on entrepreneurial education impact studies. It primarily focuses on analyzing the impact of entrepreneurship education on entrepreneurship orientations in developing countries in the field of engineering using precise pretest-posttest analysis, appropriate control group and ample sample size.

In doing so, first we just summarized the various intention theories pertaining to entrepreneurship education and entrepreneurial behavior .The next section, thus, aims to explore and analyze the robustness of the theories in explaining entrepreneurial behavior to choose the appropriate one for the study.

## **3.2. Theoretical Framework and Research Hypotheses**

### **3.2.1. Entrepreneurship Intention Theories**

*Behaviour is a mirror in which everyone shows their image* (Johann Wolfgang von Goethe)

Following the role entrepreneurship plays to intriguing employment, productivity, economic growth and development; the decision to become an entrepreneur has been studied, assessed and analyzed from different perspectives. Various theories, models and approaches have been employed to study entrepreneurial behavior along the years. The results indicated that entrepreneurial life path is attributed to range of intricate and multidimensional factors.

Early entrepreneurship research utterly detached entrepreneurial act from exogenous influences. They claimed that (entrepreneurial) intention has entirely linked with certain personality traits typical to an individual (McClelland, 1961; Brockhaus, 1980; Brockhaus and Horwitz, 1986). Personality traits are “characteristics of individuals that exert pervasive influence on a broad range of trait-relevant responses” (Ajzen, 2005).

The trait model of entrepreneurship intrinsically relies on the premise that entrepreneurs possess certain personality /or psychological traits that distinguish them from the non-entrepreneurs. It states that entrepreneurs are always born with some qualities that enable them to better act and exploit entrepreneurial opportunities prevail in life.

In this regard, the model nullifies the possibilities (entrepreneurship) education might have to intrigue entrepreneurial behavior. A potential entrepreneur, they argued, rather needs stable traits that are emblematic of an entrepreneur. Compared with other people, entrepreneurs embrace a higher achievement motivation, locus of control, risk-taking propensity, tolerance of ambiguity, self-confidence, innovation, energy level, need for autonomy and independent. These traits then form dispositions to act in an entrepreneurial way.

#### **Need for achievement**

It was developed by McClelland (1961) in furtherance to Max Weber’s work (1904, 1970) on society and economic development. The need for achievement theory states that human beings naturally have a need to succeed, accomplish, excel or achieve. It refers to the need to achieve the motivational factor in relation to the subsequent behavior.

It is thus the need to achieve and excel that drives entrepreneurs to persevere. Accordingly, need for achievement, they recounted, is the foundation to start an entrepreneurial firm. The higher the need for achievement therefore implies a higher probability to start a firm.

### **Risk-taking Propensity**

It is the perceived probability of attaining rewards or benefits regarding success prior to taking an action may result in failure (Brockhaus, 1980). It measures an individual's tendency to accept failure comfortably (Brice, 2002). Proponents of trait theory argue that entrepreneurs are more daring to take risk than the rest of the society. Related to this, Stewart & Roth (2001) parsed out the risk propensity differences between entrepreneurs and managers in a meta-analysis of twelve studies of entrepreneurial risk-taking propensity. They found that five of the studies showed no significant differences, with the remaining seven supporting the notion that entrepreneurs are moderate risk-takers.

### **Locus of Control**

It refers to “the extent to which individuals believe they can control events affecting them” (Rotter, 1966). It can be either internal or external locus of control.

People with a high internal locus of control have a high self-confidence in their ability to control and manage themselves and influence others around them. They believe that they can control events happening in life. They always think that their fate is in their own hands and that their own choices lead them to success or failure. Internally controlled individuals are more self-motivated and success-oriented. Accordingly, they are more poised to start a firm than those who don't have such qualities.

On the other hand, people with a high external locus of control believe that control over events and what other people do is outside them, and that they personally have little or no control over such things. They may even believe that others have control over them and that they can do nothing but just accept. To this end Rotter (1990) describes it as:

*“The degree to which persons expect that the reinforcement or outcome is a function of chance, luck, or fate, is under the control of powerful others, or is simply unpredictable.”*

Hence, people with an external locus of control tend to be fatalistic, seeing things as happening to them and that there is little they can do about it. They feel that their lives are heavily influenced by

forces which they cannot control such as luck, fate or powerful others. This tends to make them more passive and accepting. So their success or failure is always attributed to luck than their own efforts.

These people are less likely to have expectancy shifts, seeing similar events as likely to have similar outcomes. They always believe that all events are predetermined and therefore inevitable.

They hence step back from events, assuming they cannot make a difference.

Accordingly, internally controlled individuals are more self-motivated than those who are externally controlled. As a result people with higher internal locus of control are thought to be more entrepreneurial than those with higher external locus of control.

Lastly, **creativity** relates to perceiving and acting in new and unique ways (Robinson et al., 1991).

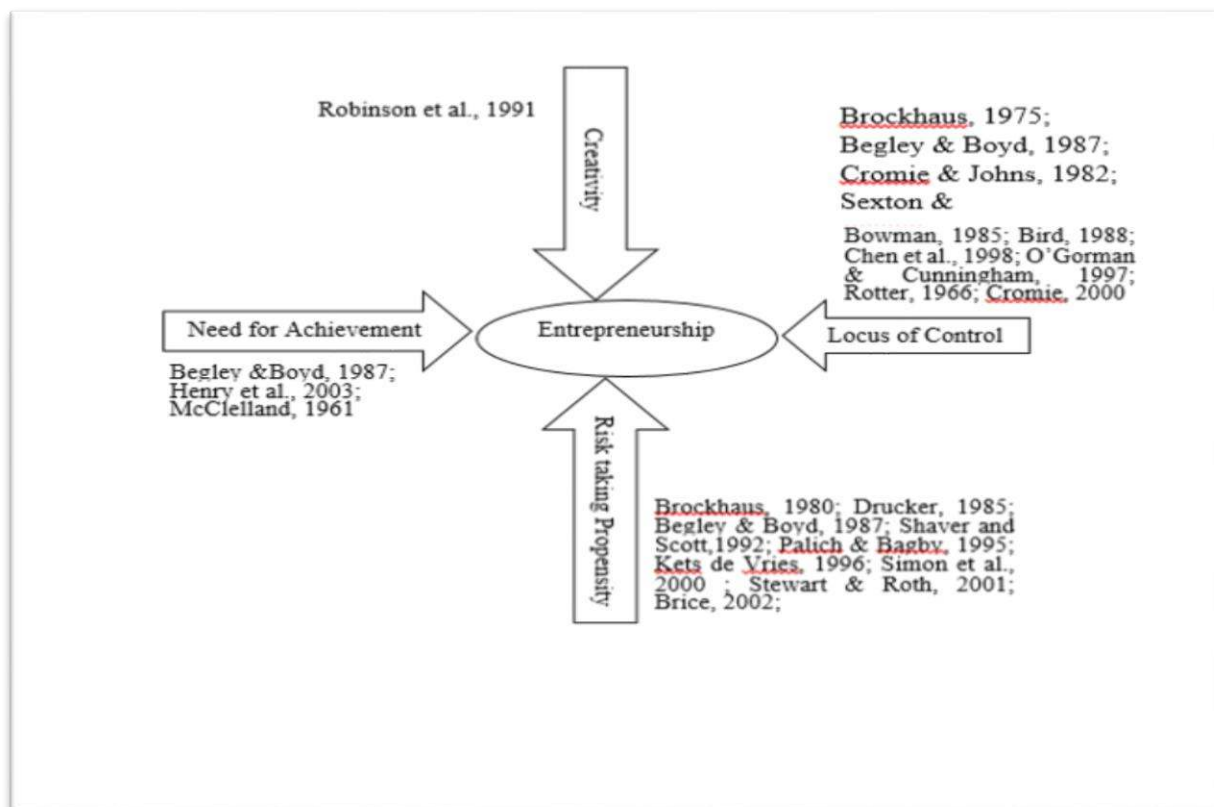

Figure 23 Trait Personality Model

The trait model, therefore, illustrates the relationships between the four most salient personality traits. As we can see from figure23, the model assumes people with higher levels of need for achievement, risk-taking propensity, locus of control (internal), and creativity are more likely to

start new firms. And these characteristics distinguish entrepreneurs from the general population. These behaviors, as of the model, are common to most successful entrepreneurs.

Critical analysis of literature unveiled two basic challenges that the trait model of entrepreneurship faces in its validity:

First, the very fact that the model assess the behavior of entrepreneurs after they start business is purely an **ex-post only** analysis that casts doubt on the real causes of the behavior. Hence, it is blatantly far-fetched and dubious if characteristics the entrepreneur possesses were already there or were acquired through life experiences and exogenous influences.

Second, the causal impact of personality traits on entrepreneurial action is not well documented. In the trait model, given the stability of personality traits, individuals could be considered as the “prisoners of their own personality traits” (Gartner, 1988). The assumption doesn’t really seem holistic. This assumption ignores the fact that entrepreneurship is a reflection of the interaction between the entrepreneurs with the environment. It failed to assess the possible influences of other factors such as social, political and economic situations (Gartner, 1988), displacements (Shapero & Sokol, 1982), changes in markets (Piore & Sabel, 1984), and government deregulation of industries (Farrell, 1985) that may create the context of entrepreneurship (Bird, 1988). Thus the trait model does not reflect the actual concerns associated with initiating an entrepreneurial endeavor.

To this end, Gartner (1988) contended that a behavioral approach which deals with what entrepreneurs do is more suitable to explaining the entrepreneurship behavior compared with the trait model that emphasizes who the entrepreneurs are. Entrepreneurs are viewed in terms of the activities they are doing to creating a new firm. Thus, the focus of entrepreneurship is to understand how behaviors, attitudes, skills and intentions altogether influence the entrepreneurial success.

On account this, the trait model for entrepreneurship gave way to models that view entrepreneurial behavior from the perspective of cognition. Cognition is considered as appropriate to explain entrepreneurial behavior. In addition, despite some exogenous factors such as disengagement from the jobs market, entrepreneurship decision is something that people usually choose to live and take intentionally. In regards, the recent focus of attention shifts to entrepreneurial intention that has become a central element to predicting entrepreneurial behavior as well as making the ultimate decision to starting a firm. Intention models help to explain the nature of entrepreneurial process before the firm comes to happen. They entrench the basic strategic templates of startups. Intention-based models can thus better explain the entrepreneurial process than the trait models do.

Accordingly, the focus of the next section becomes discussing the evolution of the different types of entrepreneurial intention models, and makes a comparison among these models to develop the appropriate conceptual framework for the study.

### 3.2.2. Intention Models

Following the critics the trait models faced, a great deal of theoretical approaches have been developed to explain why and how some people eventually become entrepreneurs.

Entrepreneurial intention model has been one of the recent research streams to explain how people start or tend to start an entrepreneurial firm. Intention to start a business is thought to be the best and unbiased predictor of actual entrepreneurial act. Intention is spot on to shape, determine and predict the propensity that an individual performs the subsequent behavior. As a result it is considered as a stepping stone for an entrepreneurial act. It has an apparent flexibility with time and behaviors. It works even where the target behavior is rare, obscure, or involving unpredictable time lags, for example in career choices (Lent et al., 1994; MacMillan and Katz 1992).

Empirics show behavior is a function of many intricate factors be it attitudes, exogenous factors that are either situational (employment status or informational cues) or individual factors (demographic characteristics or personality traits). Thus, a single factor such as exogenous factors only may not be enough to explain a behavior through intention. For the fact that exogenous factors affect intention and behavior only indirectly through changes in attitudes (Ajzen 1991), intention models offer an opportunity to increase our ability to explain and predict entrepreneurial activity.

Intentions determine the form and direction of an organization at its inception. It determines the future state of an organization. Subsequent organizational success, development (including writing business plans), growth, and change are based on these intentions, which are modified, elaborated, embodied, or transformed (Bird, 1988), against the trait model that assumes stability of behavior.

Intentions toward a behavior reflect the motivation and enthusiasm of a person to perform that behavior. Thus, stronger intentions relates with a higher likelihood of the intended behavior to happen (Ajzen; 1991). It is evidenced that intention explains about 30% of variance in behavior and this figure is much higher compared with only 10% provided by personality traits (Ajzen, 1987).

In the entrepreneurial process, entrepreneurial intention will transform business concepts or ideas into a course of entrepreneurial actions. It has been shown that entrepreneurial behavior is the product of entrepreneurial intention (Bird, 1988; Krueger & Brazeal, 1994). Hence, venture



formation always proceeds the development of entrepreneurial intention. Intentions thus serve as a conduit to better understanding the act itself (Ajzen 1987, 1991). Thus, examining entrepreneurial intention will clearly offer significant insights into business creation.

The section here in below discusses the key entrepreneurial intention models, their evolution and empirical applications. It also makes a comparison among these models in order to choose the most appropriate one for the study.

### 3.2.2.1. Entrepreneurial Event Model (EEM)

It is the first entrepreneurial intention model developed by Shapero and Sokol (1982). The model noted that perceived feasibility, perceived desirability and propensity to act are the key elements that explain an individual's intention to become an entrepreneur.

**Perceived feasibility** is defined in terms of whether one feels capable of starting a business. The concept of perceived feasibility is similar to Bandura's self-efficacy, which is often used as a measure of perceived feasibility (Krueger Jr et al., 2000).

On the other hand, **perceived desirability** is concerned with the overall attractiveness of starting a business.

The two elements together provide evidence of one's perceived credibility for new venture creation (Krueger & Carsrud, 1993). They determine an individual's response to an external event. These perceptions, in turn are derived from cultural and social factors. Hence, any factor that influences an individual's entrepreneurial intention does so only through its effect on either perceived feasibility or perceived desirability (Krueger, 2000).

Most importantly, the model predicates that inertia guides human behavior until some event interrupts or 'displaces' that inertia, and unlock previously undesired behavior, individuals may not want to start up business enterprise.

Shapero and Sokol classify these life path changes into negative displacement, between things and positive pull.

Positive displacement in this context refers to cases like winning a lottery, positive reinforcements from the teacher, friends, partner, mentor, investor or customers that propel the individual to start a business. On the other hand, negative displacements are associated with losing a job, insulted, angered, bored, reaching middle age, getting divorced or becoming widowed. At the same time neutral or being between-things refers to happenings such as graduating from high school, university, finishing military duty or being released from jail.

Despite the fact that any of these displacements, especially job-related displacements, have the potential to cause a shift in one's life path and trigger someone to engage in the start-up of a business, between-things is potentially of more interest for an entrepreneurship education course meant for students as they have no clear idea of what to do after graduation.

Displacement precipitates a change in behavior where the decision maker seeks the best opportunity available from a set of alternatives (Katz 1992). The choice of the behavior depends on the relative credibility of alternative behaviors and the propensity to act.

If a displacement event triggers cognitive processes and changes perceptions of feasibility and desirability, the individual may act if the credibility of the specified behavior is higher than the alternatives and if the individual has a general propensity to act on that action.

Shapero and Sokol (1982) strongly contended that propensity to act is a very important construct for an individual to take a certain action. It is the personal disposition to act one's decision, and hence reflecting volitional aspects of intentions ("I will do it"). It is hard to envision well-formed intentions without some propensity to act. Conceptually propensity to act on an opportunity depends on control perceptions such as the desire to gain control by taking action. As such, it is a stable personality characteristic that links strongly to locus of control, that is, the perception of control over one's life (Krueger et al., 2000).

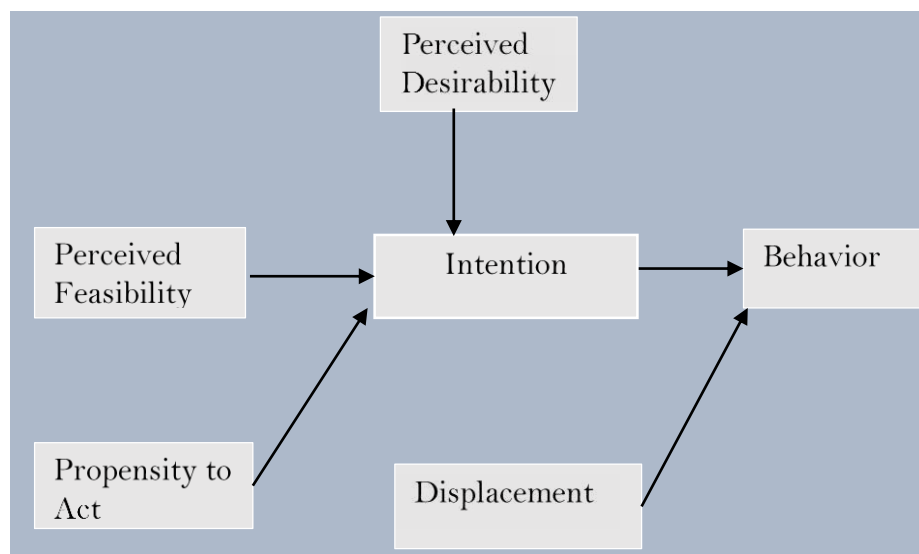

Figure 24 Entrepreneurial Event Model (EEM)

### 3.2.2.1.1. Application of EEM

Some studies have tested the applicability of EEM in explaining entrepreneurial behavior and evaluation of entrepreneurship education program. Perusal of table 41 affirms the impact of propensity to act, perceived desirability and perceived feasibility to predict entrepreneurial intention. And the results are consistent across year and country.

Table 41 Application of Entrepreneurial Event Model

Author	Result
Wang et al.(2011)	It examines the EEM in the context of college students' performance in the USA& Korea. A significant difference they found in the model is that propensity to act is not directly impacting intention but is imposing the impact by the mediation of perceived desirability and perceived feasibility. Work experience and family background will play significant roles in the formation of entrepreneurial intentions in both countries.
Krueger (1993)	Samples 126 upper division university students in <b>USA</b> . The results showed that feasibility and desirability perceptions and propensity to act significantly predict entrepreneurial intentions. Perceived feasibility was found to be significantly associated with the breadth of prior exposure, while perceived desirability was significantly related to the affirmativeness of that prior exposure.
Veciana (2005)	Aims at assessing and comparing the attitudes of 1272 university students from <b>Catalonia and Puerto Rico</b> towards entrepreneurship and enterprise formation. The results show a favorable perception of desirability of new venture creation, although the perception of feasibility is by far not so positive and only a small percentage has the firm intention to create a new company.
Audet(2002)	Using sample from Canada, the results confirm that the perceptions of the desirability and feasibility of launching a business significantly explain the formation of an intention to go into business on a long term horizon, but not a short term one.

Krueger et al.(2000)	Using a sample of 97 senior university business students in <b>USA</b> , both TPB and EEM models are valid and provide a valuable insight into entrepreneurial process
Segal et al (2005)	The ability of tolerance for risk, perceived feasibility, and perceived net desirability to predict intentions for self-employment is examined in a sample of 114 undergraduate business students at Florida Gulf Coast University, <b>USA</b> . Results indicated that tolerance for risk, perceived feasibility and net desirability significantly predicted self-employment intentions, with an adjusted R2 of 0.528.
Peterman & Kennedy(2003)	It examines the effect of participation in an enterprise education program on perceptions of the desirability and feasibility of starting a business for a sample of secondary school students enrolled in the Young Achievement <b>Australia</b> (YAA) program. Students had higher perceived desirability and feasibility to create a new business after finishing the YAA program.

### 3.2.2.2. Entrepreneurial Intention Model (EIM) and the Revised EIM

#### 3.2.2.2.1. Entrepreneurial Intention Model (EIM)

In 1988, Bird developed an entrepreneurial intention model (EIM) based on cognitive theory that elucidates human behavior (Figure25). She defined intention as “a state of mind directing a person’s attention toward a specific object or path in order to achieve a goal” (Bird, 1988, p.442).

The model identifies two basic sets of factors that affect entrepreneurship intention such as personal and contextual factors.

Personal factors include prior entrepreneurial experiences, personalities, and abilities. On the other hand, the contextual factors comprise social, political, and economic variables such as displacement, changes in markets, and government deregulation. The two factors together drive both rational and intuitive thinking which then determine entrepreneurial intention. These thought processes involve preparation of business plans, opportunity evaluation and other goal-directed activities required to set up a new company.

Hence, the model predicates that entrepreneurial intentions reflect a state of mind that guides entrepreneurs to implement business ideas. It provides guidance for entrepreneurs to start and manage a business.

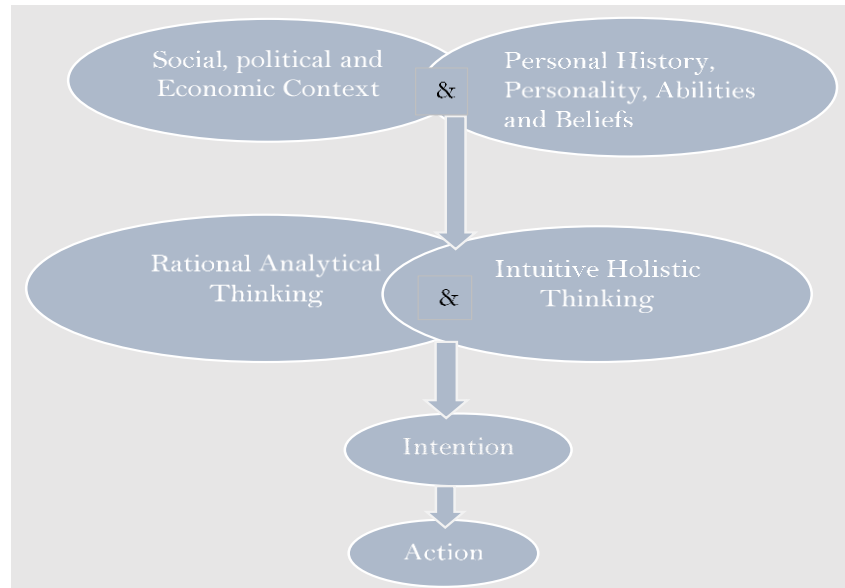

Figure 25 Entrepreneurial Intention model (EIM)

### 3.2.2.2.2. Revised EIM

Boyd and Vozikis (1994) extended Bird's (1988) EIM model by including the self-efficacy belief construct (figure26). They argued that self-efficacy is important to predict entrepreneurial intentions and behavior. It provides critical information on how intention is created in the cognitive process. According to Bandura (1982) self-efficacy captures individual capability to take an action and affects goal achievement.

Thus, in the revised model entrepreneurial intention is determined by rational analytical thinking that derives one's attitude toward a goal-directed behavior and intuitive holistic thinking that derives self-efficacy. In this model, self-efficacy is a product of the cognitive thought processes and moderates the relationship between the entrepreneurial intentions and actions.

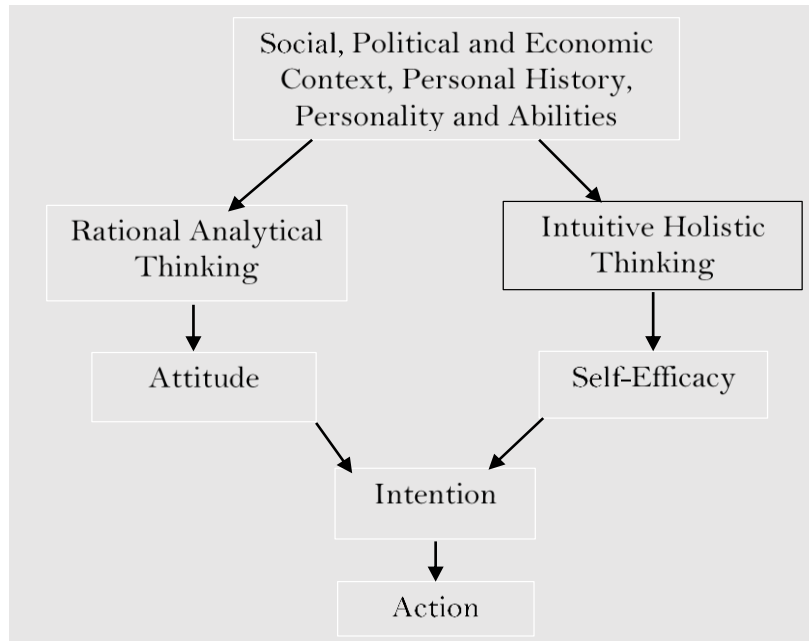

Figure 26 Revised entrepreneurial intention model (Revised EIM)

### 3.2.2.2.3. Application of EIM and Revised EIM

The EIM of Bird (1988) has widely been used to explain entrepreneurial intention theoretically. Surprisingly, empirical study testing the EIM has never been prevalent. Methodological issues may actually play for the lack of empirical test on EIM, most importantly on the revised one. For example, it may be difficult to develop measures for the constructs of “rational analytic thinking” and “intuitive holistic thinking” (Tung, 2011).

Researchers tended to employ part of the revised EIM model (“self-efficacy”) in the field of entrepreneurship practice. The revised EIM model has been applied by Zhao et al. (2005) who proposed that self-efficacy plays a critical mediating role linking background factors (e.g., perceptions of formal learning in entrepreneurship courses, previous entrepreneurial experience, risk propensity, & gender) and entrepreneurial intention. The authors used structural equation modeling (SEM) with a sample of 265 master business administration students across 5 universities to test the model.

Their results showed that the effects of perceived learning from entrepreneurship related courses, previous entrepreneurial experience, and risk propensity on entrepreneurial intentions were fully mediated by entrepreneurial self-efficacy.

Although gender was not mediated by self-efficacy, it showed a direct effect on intention. Further, Chen et al. (1998) argued that self-efficacy is useful to distinguish entrepreneurship students and entrepreneurs from non-entrepreneurship students and non-entrepreneurs. The authors also found that self-efficacy positively influences entrepreneurial intention. Recently, Wilson et al. (2007) investigated the impact of gender on entrepreneurial self-efficacy and entrepreneurial intentions for MBA students. The authors found that gender significantly affected self-efficacy and self-efficacy significantly predicted intention to start up. The mediating role of self-efficacy between background factors and entrepreneurial intention was further tested by the studies on entrepreneurial decisions (De Noble, 1999; Li, 2008).

### 3.2.2.3. Theory of Planned Behavior (TPB)

TPB emerges from Fishbein's and Ajzen's theory of reasoned Action (TRA) (Fishbein and Ajzen, 1975; Fishbein and Ajzen, 1980). The overall tenet of TRA is that a specific behavior is best predicted by the attitude towards the behavior and perceived social norms to exhibit the behavior in question. That is if people evaluate the behavior as positive and if they think their close ones want them to perform the behavior, intention to perform the behavior becomes higher.

But the TRA restricts itself to volitional behaviors. Behaviors requiring skills, resources, or opportunities not freely available are not considered to be within the domain of applicability of the TRA, or are likely to be poorly predicted by the TRA (Fishbein, 1993). That is an individual may have the intention to perform the behavior but the lack of confidence to be able to execute the behavior impedes it.

The TPB attempts to predict non-volitional behaviors by incorporating perceptions of control over performance of the behavior as an additional predictor (Ajzen, 1991). It asserts that any behavior that requires a certain amount of planning, just as is unquestionably the act of venture creation, can be predicted by the intention to adopt that behavior.

Thus the main idea of the theory of planned behavior is that it is possible to predict whether or not an individual will eventually launch a business by studying his or her intention to do so. Intentions are assumed to capture the motivational factors that influence a behavior; they are indications of how hard people are willing to try, of how much of an effort they are planning to exert, in order to perform the behavior. The stronger the intention to engage in a behavior more likely exhibits a higher performance. For the behavioral intention to find expression, however, the behavior in question needs to be under volitional control, i.e., if the person can decide at will to perform or not

to perform the behavior. In fact, as mentioned before, the performance of most behaviors depends on non-motivational factors as availability of requisite opportunities and resources such as time, money, cooperation of others (Ajzen, 1985). These, factors represent people's actual control over the behavior. Hence, to the extent that a person has the required opportunities and resources, and intends to perform the behavior, he or she should succeed in doing so (Ajzen, 1991).

It posits three distinct attitudinal antecedents/ predictors of intention: individuals' attitude toward the behavior (do I want to do it?), subjective norm (do other people want me to do it?), and perceived behavioral control (do I perceive I am able to do it and have the resources to do it?) (Ajzen, 1991; Ajzen and Fishbein, 1980). These antecedents lead to the formation of behavioral intentions (Ajzen, 2006). As such, exogenous factors affect intention and behavior indirectly through their effect on attitudes.

1. **Attitude towards the behavior** refers to a person's overall evaluation of whether performing the behavior is good or bad (Ajzen, 1991). It measures the feelings an individual has toward performing the behavior in question. It is the degree to which a person has a favorable or unfavorable evaluation or appraisal of the behavior. Hence, it embraces the person's assessment of the expected outcomes of performing the behavior. For example, a person who believes that it is beneficial to perform a given behavior will have a positive attitude toward that behavior, otherwise, will hold a negative attitude.

2. **Subjective norm** refers to the social pressures perceived by individuals to perform or not to perform the behavior. It is a person's belief that people who are important to the person—parents, friends, and peers— think that he or she should, or should not perform the behavior (Ajzen, 1991) save their motivation to comply with those referents (Fishbein,1980). An individual is likely to perform a behavior if significant others who the person is motivated to comply approve of going for it. Conversely, the person will suffer a subjective norm that forces them to avoid performing the behavior.

3. **Perceived Behavioral Control** is an individual's judgment of the likelihood of successfully performing the intended behavior (Ajzen, 1991). It is the perception of easiness or difficulty in performing the behavior. It is the perceived ability to execute the target behavior (Ajzen, 1987). It relates to the beliefs about the availability of supports and resources or barriers to performing an entrepreneurial behavior (control beliefs).



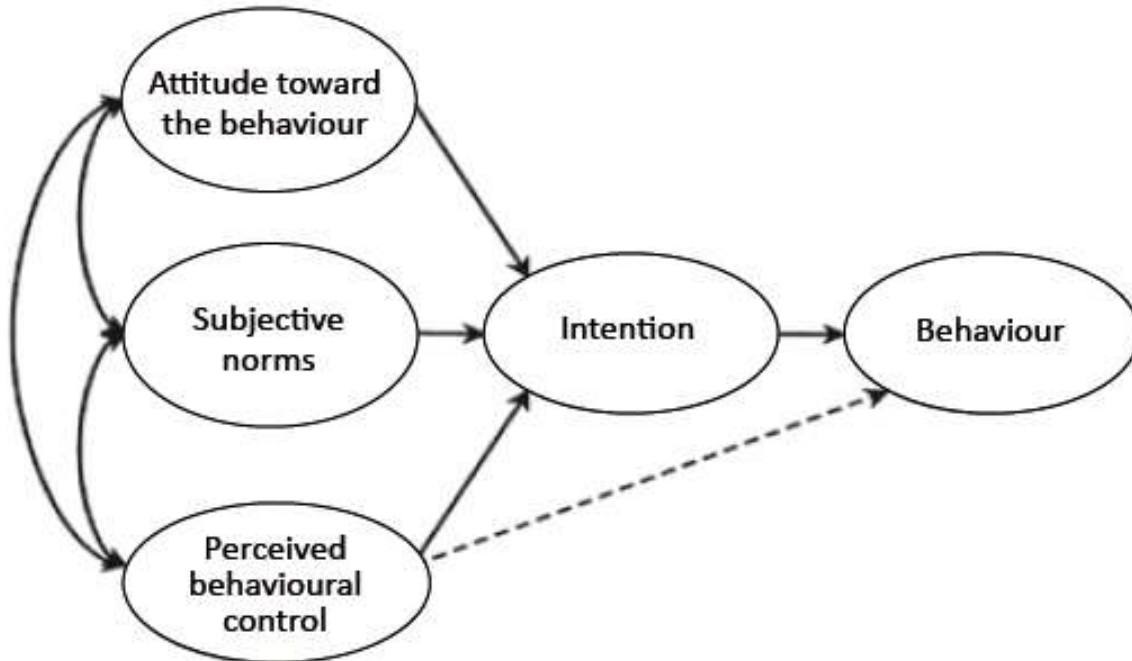

Figure 27 Ajzen's Theory of planned behavior (TPB)

Perceived behavioral control was introduced into the theory of planned behavior to accommodate the non-volitional elements inherent, at least potentially, in all behaviors (Ajzen, 2002) as many behaviors pose difficulties of execution that may limit volitional control. To the extent that people are realistic in their judgments of a behavior's difficulty, a measure of perceived behavioral control can serve as a proxy for actual control and contribute to the prediction of the behavior in question (Ajzen, 2006). In this sense, perceived behavioral control is held to influence behavior indirectly by its impact on intention and when it is veridical, it provides useful information about the actual control a person can exercise in the situation and can therefore be used as an additional direct predictor of behavior. But the magnitude of the perceived behavioral control-intention relationship is dependent upon the type of behavior and the nature of the situation (Ajzen, 1991). With respect to the influence of perceived behavioral control on intention, he states that the significance of the three antecedents of intention—attitude, subjective norm, and perceived behavioral control in the prediction of intention is expected to vary across behaviors and situations. That is in situations where attitudes are strong or normative influences are powerful, perceived behavioral control may be less predictive of intentions.

### 3.2.2.3.1. Empirical Evidence of Application of TPB

The theory of planned behavior has long been applied to predict a broad range of behaviors. A great deal of research has been devoted to testing, advancing, and criticizing the theory of planned behavior and it has been proved valid, robust and replicable to predict entrepreneurial behavior through intention.

Perusal of table 42 showed that attitude toward entrepreneurship, subjective norm and perceived behavioral control significantly explained entrepreneurial intention. The three TPB variables explain 27%-51% of the variance in intention. Once again, overview of the table shows that though all the three antecedents of entrepreneurial intention contribute for its change, perceived behavioral control was observed as the most important determinant of entrepreneurial intention. We also learned that intention explains 30%-55% of the variance in behavior.

To put in perspective, Ajzen (1987), Kim & Hunter (1993), Krueger et al. (2000), and Autio et al. (2001) found that it was only 10% of the behavior that was explained by trait measures or by attitudes, which noticeably shows the ostensible higher explanatory power of intention measures compared to trait measures of behavior.

Table 42 Summary of Pervious Studies on Using Theory of Planned Behavior

Author	Focus and Result
Van Gelderen et al (2006)	The study aims to assess the entrepreneurial intention of 1225 fourth year <b>Business Administrative</b> students in the Netherlands. The result shows that the two important variables to explain entrepreneurial intention of students were entrepreneurial alertness and the importance attached to financial security. The model explains <b>38 %</b> of the variance in EI.
Krueger et al (2000)	Based on sample comprised 97 senior university business students in USA, they found that the TPB variables explain over <b>35%</b> of the variance in intentions.
Godin & Kok (1996)	It aimed to review applications of Ajzen's theory of planned behavior in the domain of

	<p>health and to verify the efficiency of the theory to explain and predict health-related behaviors. Attitudes, subjective norm and perceived behavioral control explain <b>41%</b> of the variance in intention. The prediction of behavior yielded <b>34%</b>.</p>
Tung (2011)	<p>A sample of 411 students from 4 universities in China was used to explain education-intention relationship using TPB.</p> <p><b>50%</b> of variance in entrepreneurial intention was explained by the three antecedents</p>
Gird & Bagraim (2008)	<p>The theory of planned behavior was tested using 247 final year commerce students in two South African universities. The three antecedents significantly explain <b>28%</b> of variance in entrepreneurial intention.</p>
Kautonen et al (2011)	<p>The study investigates the efficacy of the TPB in predicting entrepreneurial behavior in a sample of 117 working-age individuals from Western Finland</p> <p>The model accounts for <b>41% and 39%</b> of the variance in intention and behavior respectively.</p>
Garba et al (2014)	<p>It sampled 312 <b>management and administrative students</b> in Nigeria. The results show that perceived desirability has statistically significant relationship with entrepreneurial intention, while the perceived feasibility has no significant relationship with entrepreneurial intention.</p>

<p>Muofhe et al (2011)</p>	<p>269 final-year students, of which 162 (60.2%) were <b>entrepreneurship</b> and 107 (39.8%) non-entrepreneurship students from a higher education institution in Johannesburg, South Africa. They found that entrepreneurship students have stronger entrepreneurial intentions than non-entrepreneurship students, and that there is a positive relationship between entrepreneurship education and entrepreneurial intentions and between role models and entrepreneurial intentions respectively.</p>
<p>Buttar (2015)</p>	<p>636 Turkish and Pakistani undergraduate <b>business students</b>. The study reveals that Social capital shapes the entrepreneurial intentions of young people through the cognitive infrastructure</p>
<p>Izedonmi &amp; Okafor (2010)</p>	<p>250 students who currently have entrepreneurship as one of their courses in Nigerian institution of higher learning. Student's exposure to entrepreneurship education has a positive influence on the students' entrepreneurial intentions</p>
<p>Armitage, C. J. and Conner, M. (2001)</p>	<p>In a meta-analytic review of 185 independent studies it revealed that the TPB accounted for 27% and 39% of the variance in behavior and intention, respectively. The perceived behavioral control (PBC) construct accounted for significant amounts of variance in intention and behavior.</p>

Fini et al (2009)	Relying on a sample of 200 entrepreneurs, founders of 133 new-technology-based firms in Italy, the results show that entrepreneurial intention is influenced by psychological characteristics, by individual skills and by environmental influences
Linan and Chen_(2006)	533 individuals from Spain and Taiwan. Results are generally satisfactory, indicating that the model is probably adequate for studying entrepreneurship.
Solesvik (2007)	Investigated the intentions to become an entrepreneur among 192 Ukrainian business students. It is concluded that individuals are driven to entrepreneurship by entrepreneurial self-efficacy, risk-taking propensity, attitudes, subjective norms, perceived behavioral control.
Linan and Chen (2009)	TPB explains 55.5% of the variance in intention using 132 business and economic university students from Taiwan and 387 business and economics university students from Spain.
Kautonen et al. ( 2013)	Based on a sample of 969 adult population from Austria and Finland demonstrates the relevance and robustness of the theory of planned behavior in the prediction of business start-up intentions.  TPB variables explain 59% of the variance in intention while Intention and PBC explain 31% of the variation in subsequent behavior.

Ariff et al (2010)	<p>Using sample of 121 final year Malay accounting students, the study identifies factors that influence students' intention to become an entrepreneur based on the model of the Theory of Planned Behavior (TPB). Among the three antecedents, perceived behavioral control emerged as the strongest factor that influence intention.</p> <p>Almost 38% of the variance in entrepreneurial intention was significantly explained by the three independent variables of attitude towards entrepreneurship, subjective norms and perceived behavioral control.</p>
Hussain (2015)	<p>The sample for this study composed of 499 final year business students from Pakistan. The result of this study supports the entrepreneurial intentions model based on the theory of planned behavior</p>
Tsordia (2015)	<p>Based on sample of 186 business management students. The three components of the Theory of Planned Behavior seem to play a differentiated role in the formation of the entrepreneurship intentions of business students, with subjective norms proved to be insignificant in the process of intention formation. The results showed that the independent variables attitude toward behavior, subjective norm and perceived behavioral control explained 44.1% of the variance of entrepreneurial intention.</p>

Küttim(2014)	55781 students from 17 European Countries with 30.2% studied business and economics, 30.5% natural sciences, 17.3% social sciences and 22% studied other specialties. Participation in entrepreneurship education was found to exert positive impact on entrepreneurial intentions (0.3).
Kaijun and Sholihah (2015)	The study involved 109 students from Business School of Hohai University in China and 110 students from Business School of Brawijaya University in Indonesia. The results of this study, as of the objective, demonstrate the significance of subjective norm and perceived behavioral control to entrepreneurial education in Chinese students. It also found indirect effect of perceived behavioral controls on entrepreneurial intention with entrepreneurial education as an intervening variable among Chinese students.
Karimi (2014)	A sample of 205 participants in entrepreneurship education programs at six Iranian universities. The findings contribute to the theory of planned behavior.
Byabashija & Katono (2011)	The sample constituted of 167 undergraduate students registered for business courses at three Universities in Uganda. Intentions have been shown to explain 30% of the variance in behavior
Fayolle et al., 2006	275 French students following a specialized Master in Management. The three antecedents

	explain from 36% to 51% of the variance in intention.
Autio et al., 2001	University 3445 students from Finland, Sweden, USA and the UK. The international comparisons indicate a good robustness of the model. Perceived behavioral control emerges as the most important determinant of entrepreneurial intent. TPB have shown to account for 30% to 55% of the variance in behavior and 30.3% of variance in intention.
Kolvereid, 1997	Employed the TPB to predict the employment choice of 128 Norwegian undergraduate business students. The result strongly supported the theory of planned behavior.
Tkachev & Kolvereid, 1999	Tested the theory of planned behavior using a sample of 512 Russian university students and the results showed that the theory of planned behavior determined employment status choice intention. TPB explains <b>45%</b> of the variance in intention
Souitaris et al., 2007	250 Science and engineering students in England and France. The findings contribute to the theories of planned behavior <b>32%</b> of variance in entrepreneurial intention was explained by the three antecedents
Moriano et al.(2011)	Based on a sample of 1074 students from Germany, India, Iran, Poland, Spain, and the Netherlands, they assessed the entrepreneurial career intentions of the students. Results support culture universal effects of attitudes and perceived behavioral control (self-



	efficacy) on entrepreneurial career intentions, but cultural variation in the effects of subjective norm
Malebana(2014)	Using 329 final-year commerce students in a rural university in South Africa based on the theory of planned behavior (TPB). The results indicate that entrepreneurial intention of the respondents can be predicted from the attitude towards becoming an entrepreneur, perceived behavioral control and subjective norms. They accounted for <b>49.2% of variance in entrepreneurial intention.</b>
Ajzen (1991)	Attitudes explain over <b>50% of the variance in intentions</b> and, on average, intentions explain about 30% of the variance in behavior

### 3.2.3. Discussion and Selection of Theoretical Framework

This section covers the advantages and disadvantages of the three models in relation to parsimony and robustness to explaining and answering the research questions and developing the most appropriate theoretical framework.

First we assessed them based on their underlying theories, intention, and goal-setting theory and self-efficacy theory. The results revealed that all the three models such as EEM, TPB and the revised EIM are not mutually exclusive. They evinced a high degree of compatibility. The intention theory pinpoints the EEM and TPB while goal-setting and self-efficacy theory applies for revised EIM.

As pointed out above, intention is the foundation for a planned and volitionally controlled behavior. It acts as a bridge to mediate the influence of attitude on behavior. External factors such as background factors and personalities influence intention through their effect on entrepreneurial attitudes though there are some evidence that shows they also exert a direct and significant impact on the formation of intentions (Ajzen & Fishbein, 1980; Krueger, 1993; Shapero & Sokol, 1982).

The goal-setting theory states the relationship between goals and action, or goals and task performance (Locke & Latham, 1990). It further asserted that people who are provided with specific, difficult but attainable goals perform better than those given easy, nonspecific, or no goals at all. At the same time the individual, however, must have sufficient ability to accept the goals, and receive feedback related to performance (Latham, 2003). In this sense, goal commitment (the extent to which a person persist in pursuing a goal) and self-efficacy effectuate the relationship between goals and performance.

Self-efficacy theory is at the heart of social cognitive theory, which states that social behavior occurs through the proactive engagement of people who make the behavior happen by their own actions. Accordingly a person's attitudes, abilities, and cognitive skills constitute the self-system. This system governs how people perceive situations and how people behave in response to different situations (Bandura, 1986).

Literature shows the three theories are similar in meaning though they may be applied to different domains. For example, a **goal** may represent the extent which a person wants to achieve some outcomes through tackling barriers ahead. As noted by Locke and Latham (1990), a goal indicates desired outputs as the level of performance. In the goal-setting theory, attitudes are derived from group norms (normative information) and considered to affect the desirability of performance goals. In this regard, Ajzen (1991) contended that every behavior can be considered as a goal and to achieve the goal, a course of specific actions will be taken. Thus, goal and intention is largely homologous. Moreover, self-efficacy is an important concept for all these three models. Self-efficacy has significant impact on goal performance. The higher the self-efficacy, the higher goal performance and commitment will be (Locke & Latham, 1990; Seijts & Latham, 2001). Perceived behavioral control or feasibility is similar in meaning to self-efficacy. Self-efficacy is a significant component of intention theory that basically reflects the perceived behavioral control over an entrepreneurial behavior (Krueger, 1993; Krueger et al., 2000).

Given the compatibility of their underlying theories and the function of self-efficacy, the EEM, revised EIM, and TPB are therefore complementary in that they are related to different domains but adopt similar approaches.

The three models also show consistency in considering the concepts of individual attitude or desirability and perceived capability to take entrepreneurial actions. For example, the "perceived desirability" of EEM, "attitudes" of revised EIM, and "attitude toward entrepreneurship" of TPB

are used to describe the perceptions about entrepreneurship (i.e., attractiveness or desirability of starting up). Also, these three models use perceived feasibility, self-efficacy or perceived behavioral control to describe the effect of perceived capability on entrepreneurial intention.

The three models also consider personality traits and contextual factors on decision making on entrepreneurial behaviors. In these models, personality traits are external factors influencing intention indirectly through their effect of attitudes. This is because the personality factors catch certain beliefs and perceptions about behaviors (Ajzen, 2005). For example, locus of control relates to one's control beliefs, which refer to one's perceived capability to take an action (Ajzen, 1991). In the EEM, propensity to act is the disposition to act upon one's decisions. Shapero and Sokol (1982) considered this factor as a stable personality trait which is highly related to locus of control. The EEM suggests that internally controlled people are more likely to engage in entrepreneurial activities. In fact, propensity to act in EEM has been empirically found to affect perceived desirability and feasibility (Krueger, 1993).

In terms of situational or contextual factors, the EEM considers the precipitating (or displacing) events, including job loss, an inheritance etc.

Entrepreneurial decision would be affected by some external changes (Shapero & Sokol, 1982). The revised EIM considers the contextual factors of social political and economic context affecting the thought process of entrepreneurs (Bird, 1988; Boyd & Vozikis, 1994). While the TPB uses the construct of perceived behavioral control to reflect effect of contextual factors (i.e. difficulties or easiness) such as resources, support or constrain received (Ajzen, 1991).

As outlined above, the revised EIM has received the least empirical support. According to (Drnovsek & Erikson, 2005), the whole revised EIM has yet to be validated empirically while the EEM and TPB models have been well tested. Although the mediating role of self-efficacy between the background factors and intention has been well tested (Chen et al., 1998; De Noble et al., 1999; Li, 2008; Wilson, et al., 2007; Zhao et al., 2005), the entire revised EIM model has not been empirically tested. Therefore, the revised EIM is less appropriate to be used in this study compared with the other two models.

The role of social norms/ subjective norms remains elusive in both the revised EIM and EEM. In the revised EIM and EEM, attitude toward creating a new business is considered as a broad concept that factors at both personal and social levels influencing one's desirability or willingness are merged altogether.

On the other hand, TPB clearly distinguishes attitude pertaining to personal interest or attraction regarding the entrepreneurial behavior (personal level), and attitude due to social influence (i.e., social level). Such separation of the attitudinal antecedents is meaningful and necessary as it provides more detailed information compared with the other two models.

In fact, not only the personal assessment of entrepreneurship is important, but also the opinions of other people who are important to the person (Ajzen, 1991; 2005).

Those significant people may include a person's parents, spouse, close friends, coworkers, teachers, classmates and experts in the field. Therefore, subjective norm which refers to how significant others view the person engaging in entrepreneurship is an important influencing factor of entrepreneurial intention. The person will be more likely to perform the entrepreneurial behavior if significant people think that he should do so. Otherwise, the person would avoid entrepreneurship if those people disapprove and she/he complies with that. Subjective norm is especially important for students on campus, since they usually lack confidence and experience to make decisions on their career choice. Thus, they can be easily influenced by their teachers, parents and friends.

Among these intention models, only TPB extends the antecedents of entrepreneurial intention to a social level. As this factor presumably has a direct effect on entrepreneurial intention, theory of planned behavior provides a clearer picture of how the entrepreneurial intention develops. In this sense, it allows to examine how entrepreneurship education influences intention through its effect on one or all of the variables of the theory of planned behavior.

At last, the entrepreneurial event model is like a complement to the theory of planned behavior. The concept of perceived self-efficacy in the entrepreneurship event model is similar to perceived behavioral control in the theory of planned behavior. In addition, the remaining components of the theory of planned behavior such as attitude toward entrepreneurship and subjective norm are similar to entrepreneurship event model's perceived desirability.

To this end, EEM can be considered as a particular application of the TPB that provides more detailed information about intention (Krueger et al., 2000)

Generally, the overview of the three model of entrepreneurial intention shows that the Theory of Planned behavior is superior to the other models to study entrepreneurial behavior of students. It provides more detailed information about formation of entrepreneurial intention and has received a wide range of empirical support. Thus we choose the Theory of planned behavior as the theoretical basis for this dissertation study.

### 3.2.4.Hypotheses

The overview of previous studies provides two strands of information. On the one hand, we observed an overly positive impact of entrepreneurship education on the intention toward entrepreneurship. On the other hand, the studies apparently faced serious methodological deficiencies that calls for more robust impact studies.

In the next section, we briefly discuss the hypotheses proposed with regard to the research gaps already identified above.

#### **Hypothesis 1: Impact of Entrepreneurship Education on Entrepreneurial Intention**

The overview of entrepreneurship education impact studies above indicated that the majority of them came up with positive result. More specifically, entrepreneurship education is considered to enhance entrepreneurial behavior. As highlighted in the theory of planned behavior, the theoretical model chosen for study, the effect of entrepreneurship education influences behavior through its effect on intention, which is a function of attitude toward entrepreneurship, subjective norm and perceived behavioral control. In this regard, the effect of education on behavior is an indirect one through intention which in itself is not directly affected by education. The effect is rather through the three antecedents of intention (the attitude model of entrepreneurship).

At this point, Robinson et al (1991) claimed that the model has ramifications for entrepreneurship education programs by the virtue that attitudes are liable to change and can be influenced by educators and practitioners. They asserted that the variables of the theory of planned behavior vary more easily and more often than personality traits.

Entrepreneurship education should, hence, impact the constructs of the theory of planned behavior. All three constructs, attitude toward behavior, perceived behavioral control, and subjective norms are expected to be positively influenced, albeit on a high level, by the entrepreneurship education programs. In turn, as entrepreneurial intention is impacted by these variables as the theory of planned behavior states, intention will be positively influenced by the entrepreneurship education program and that the entrepreneurial group will have higher scores on the constructs than the control group can have at the end of the program.

Based on these premises we state the first hypotheses as:

## **Hypotheses 1.1:**

H1: Entrepreneurship education positively affects attitude towards the behavior

H2: Entrepreneurship education positively influences subjective norms

H3: Entrepreneurship education positively affects perceived behavioral control.

H4: Entrepreneurship education positively impacts entrepreneurial intention.

H5-H7: The greater the attitude toward behavior, subjective norms and perceived behavioral control with regard to entrepreneurship, the greater the entrepreneurial intention.

As outlined so far, the effect of the three antecedents of the theory of planned behavior is not constant and equal across the three. Their effect varies across behaviors and situations. But compared with the effect of attitude and perceived behavior controls on intention, the relationship between subjective norm and entrepreneurial intention is relatively inconsistent. Some studies show a significant positive impact (Kolvereid, 1996; Tkachev & Kolvereid, 1999; Kolvereid & Isaksen, 2006; Iakovleva and Kolvereid, 2009; Kautonen, Luoto and Tornikoski, 2010; Leffel and Darling, 2009; Liñán and Chen, 2009; Pejvak, et al. 2009) while others could not establish a clear relationship between subjective norm and entrepreneurship intention (Autio et al., 2001; Krueger et al., 2000; Huda et al, 2012). Some even reported negative effects (Shook and Bratianu, 2010). It thus inquires more empirical studies on the relationship between subjective norm and entrepreneurial intention.

## **Hypothesis 1.2: The Interrelationship among the Three Antecedents**

The effect of the three antecedents of attitude toward entrepreneurship, subjective norm and perceived behavioral control on intention has not been constant across situations.

At some point attitude toward entrepreneurship is more important than other antecedents in determining some intentions while on another point subjective norms or behavioral controls are more important than attitude. Thus the three antecedents are not mutually exclusive. They depend one another. One antecedent may share the covariance of the other to form intention to entrepreneurship (Ajzen, 1985; 1991; 2005; De Vries et al., 1988).

The following section discusses the inter-relations among the three antecedents of intention to do a behavior.

## **Subjective Norm and Attitude toward Entrepreneurship**

We used persuasion theory (Eagly & Chaiken, 1993) and cognitive dissonance theory (Festinger, 1957) to explain the relationship between subjective norm and attitude toward entrepreneurship.

Persuasion theory aims at changing a person's (or a group's) attitude or behavior toward some event, idea, object, or other person(s) through written or spoken words to convey information, feelings, or reasoning, or a combination thereof (Eagly & Chaiken, 1993). People presumably internalize the opinions and advice of others consequently change their prior attitude toward a behavior. So, though it may not always be true, persuasion messages and information received will affect a person's future decision or action by being part of the memory.

The cognitive dissonance theory, on the other hand, suggests that a person is likely to change his/her decision or behavior to seek cognitive consistency when inconsistency exists (Festinger, 1957). Thus, a person may change his or her attitude toward a behavior in order to feel affiliated with people who are significant to this person. In the our case, when the person believes that significant referents (e.g., parents, teachers, and friends) think an entrepreneurial career should be pursued, he or she may change attitude to be positive toward entrepreneurship so as to feel affiliated with the referents. This is especially true for students as most of them lack confidence and experience to make decision on their career choices. In regards, subjective norm can be taken as a specific form of social capital that impacts attitude toward a behavior (Liñán and Santos, 2007)

There is also empirical evidence in business research that indicates the positive relationship between subjective norm and attitude (Al-Rafee and Cronan, 2006; Chang, 1998; Liao et al., 2010; Lim and Dubinsky, 2005; Taylor and Todd, 1995).

Accordingly, in the context of entrepreneurship education, students' attitude toward entrepreneurship is likely to be influenced by significant others, including their parents, teachers, friends, and successful entrepreneurs/entrepreneurial experts. Thus, normative beliefs are likely to affect one's attitude and decision making toward a behavior. Basing on this, we postulate the following hypothesis about the relationship between subjective norm and attitude toward entrepreneurship:

H8: Subjective norm positively affects attitude toward entrepreneurship.

### **Subjective Norm and Behavioral Control**

We explained the relationship between the two antecedents using Bandura's Social Cognitive Theory (1986). According to this theory, social persuasions play an important role in one's

capability beliefs. It claimed that people could be encouraged or persuaded that they have the right skills and capacity to successfully perform a behavior. When other people encourage and convince a person to perform a task, she/he tend to believe that she/he is really more capable of accomplishing the task. For example, the verbal encouragement of “I know you will succeed” could help a person build confidence and achieve a goal. Such encouragement could help people to overcome self-doubt and concentrate on their effort on performing a task (Bandura, 1997). Thus, persuasive comments have significant impact on one’s capability beliefs.

Effective persuasive comments make people trust in their capabilities and ensure that they have certain control over the behavior. This infers that the more positive comments of significant people on someone’s decision on engaging in entrepreneurial behaviors, the stronger capability beliefs to perform well these behaviors she/he will perceive.

H9: Subjective norm positively influences the perceived behavioral control toward entrepreneurship.

### **Behavioral Control and Attitude toward Entrepreneurship**

Entrepreneurship is such a complex and challenging act that involves huge risks and uncertainties. It is thus imperative to quest for the skills, abilities, confidence and resources required of overcoming the uncertainties and control over the entrepreneurial actions. The higher the perception of control reflects the more positive evaluation of the entrepreneurial action (i.e., carrying out the entrepreneurial action successfully) an individual will have. According to TPB, evaluation of the entrepreneurial behavior is the belief about the expected consequence of entrepreneurship (i.e., behavioral belief), which reflects one’s attitude toward entrepreneurship (Ajzen, 1991; 2005).

A person who believes that the entrepreneurial action will succeed (i.e., positive outcomes) will hold a favorable attitude toward performing the entrepreneurial behavior.

In other words, when positive outcomes of the entrepreneurial action is evaluated or expected, a favorable attitude toward the entrepreneurial action will be attained. This is supported by the expectancy theory that when outcomes of a behavior are expected, positive evaluation or attitude will be produced (Eagly & Chaiken, 1993; Feather, 1982). In this sense, the higher perceived control over the entrepreneurial behavior, the more favorable attitude toward the entrepreneurial behavior because of the higher expectancy of the outcomes. Therefore, we propose that perceived behavioral control has a positive relationship with attitude toward entrepreneurship.

**H10:** Perceived behavioral control positively influences attitudes toward entrepreneurship.



### 3.2.5. Summary of the Conceptual Model

Summarizing all the hypotheses proposed above, the entrepreneurial intention conceptual model is developed as shown in figure 28. It shows the relationship between entrepreneurship education and the antecedents to entrepreneurship. It also indicates the relationship among the three antecedents of entrepreneurial intention. Furthermore, it portrays the relationship between entrepreneurship intention and its antecedents such as attitude toward entrepreneurship, subjective norm and perceived behavioral control.

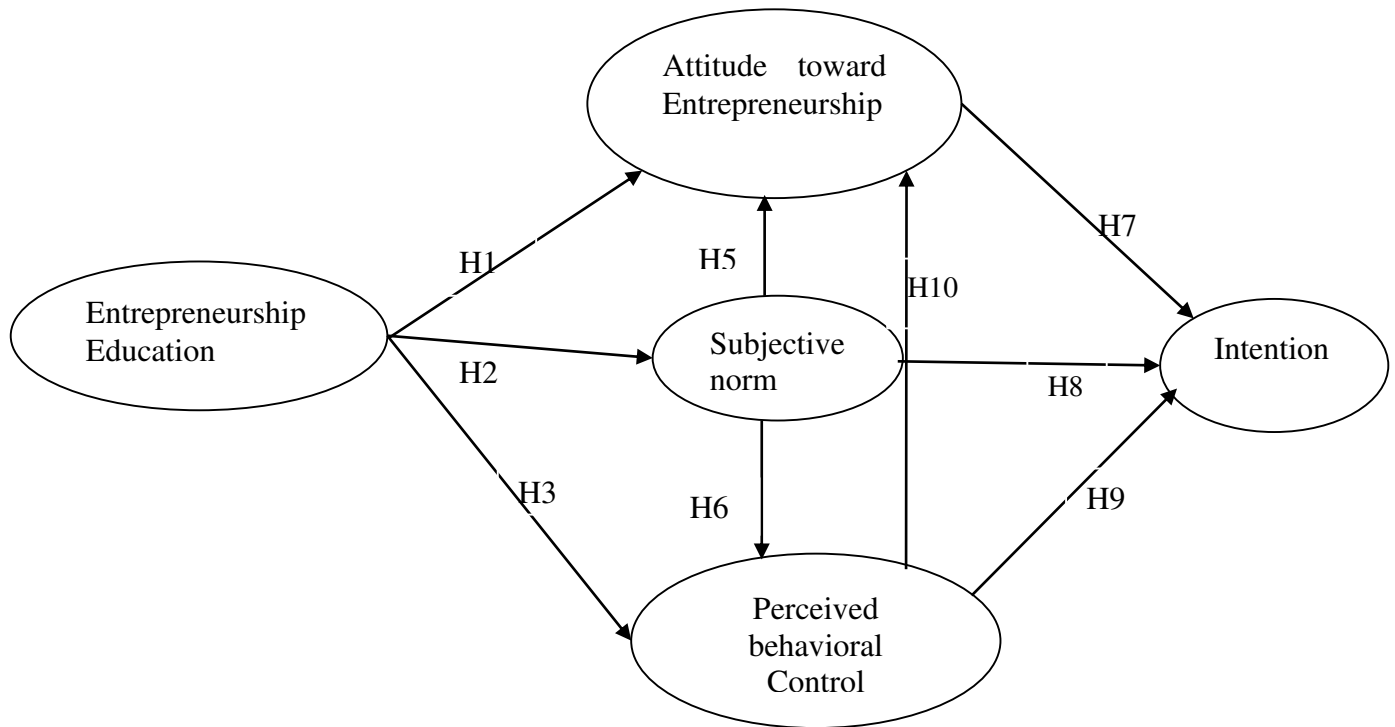

Figure 28 Education-Entrepreneurship Intention Model

## Bibliography

- Acs, Z. J.; Arenius, P.; Hay, M., and M. Minniti. (2005). *2004 Global Entrepreneurship Monitor* (London U.K. and Babson Park, MA: London Business School and Babson College).
- Acs, Z. (2007). How is Entrepreneurship Good for Economic Growth? *Innovations*, 1 (1), 97-107.
- Addario, S and Vuri, D. (2010). Entrepreneurship and Market Size: The Case of Young College Graduates in Italy. *IZA Discussion Paper* No. 5098.
- African Energy Outlook, 2014. A Focus on Energy Prospects in Sub-Saharan Africa. *A World Energy Outlook Special Report*,  
[https://www.iea.org/publications/freepublications/publication/WEO2014\\_AfricaEnergyOutlook.pdf](https://www.iea.org/publications/freepublications/publication/WEO2014_AfricaEnergyOutlook.pdf)
- Ahmad, N. and Hoffman, A. (2008). A Framework for Addressing and Measuring Entrepreneurship. *OECD Statistics Working Papers*.
- Akwani, O. A. (2007). Manufacturing in Nigeria – the Many Huddles Facing the Small Manufacturers accessed from <http://www.indirectory.com/village/global/business-finance/manufacutringnigeria.asp>.
- Alarape, A., A. (2007). Entrepreneurship Programs, Operational Efficiency and Growth of Small Businesses. *Journal of Enterprising Communities*, 1(3): 222-239.
- ALberti, F., Sciascia, S., Poli, A. (2004). Entrepreneurship Education: Notes on an Ongoing Debate. *14<sup>th</sup> Annual IntEnt Conference*. Italy: University of Napoli Federico II.
- Aldrich, H., Zimmer, C. (1986). Entrepreneurship through Social Networks' in Sexton, D. L., Smilor, R. W. (eds.) *The Art and Science of Entrepreneurship*, (Cambridge: Ballinger Publishing Company)
- Allen, I. E., N. Langowitz, and M. Minniti. (2007). Global Entrepreneurship Monitor – 2006 Report on Women and Entrepreneurship, Babson College and London Business School.
- Alba-Ramirez, A. (1994). Self-Employment in the Midst of Unemployment: the Case of Spain and the United States. *Applied Economics*, 26, 189-20.
- Ahmad, N. and Seymour, R.G. (2008). *Defining Entrepreneurial Activity: Definitions Supporting Frameworks for Data Collection*. OECD Statistics Directorate Working Paper, STD/DOC(2008)1.
- Aldrich, H., B. Rosen, & W. Woodward. (1987). The Impact of Social Networks on Business Foundings and Profit: A Longitudinal Study. *Frontiers of Entrepreneurship Research*, eds. N.C. Churchill, John A. Hornaday, Bruce A. Kirchoff, O. J. Krasner, & Karl H. Vesper, 154–168. Wellesley, MA: Babson College.
- Alfaro, L. and Charlton, A. (2006). International Integration and Entrepreneurship, *CEPR Discussion Paper No 755*.
- Al-Rafee, S., & Dashti, A. E. (2012). A Cross Cultural Comparison of the Extended TPB: The Case of Digital Piracy. *Journal of Global Information Technology Management*, 15(1), 5-24.
- Amit, R., Glosten, L., & Muller, E. (1993). Challenges to Theory Development in Entrepreneurship Research. *Journal of Management Studies*, 30: 815-834.
- Andersson, L & Hammarstedt, M. (2011). Ethnic Enclaves, Networks and Self-Employment among Middle Eastern Immigrants in Sweden.” *International Migration*, Volume 53, Issue 6, pages 27–40.

- Antoncic, B. and Hisrich, R.D. (2001). Intrapreneurship: Construct Refinement and Cross-Cultural Validation. *Journal of Business Venturing*, 16(5): 495-527.
- Arano, K., Parker, C., and Terry, R. L. (2010). Gender-Based Risk Aversion and Retirement Asset Allocation. *Economic Inquiry*, 48(1):147–155.
- Ardagna, S., and Lusardi, A. (2008). Explaining International Differences in Entrepreneurship: The Role of Individual Characteristics and Regulatory Constraints. *NBER Working Paper* No. 14012.
- Arenius, P., and Clercq, D. D. (2005). A Network-based Approach on Opportunity Recognition. *Small Business Economics*, 24(3), 249–265.
- Arum, R. and Mueller, W. (2004). *The Reemergence of Self-employment: a Comparative Study of Self-employment Dynamics and Social Inequality*, Princeton, N.J: Princeton University Press
- Athayde, R. (2009). Measuring Enterprise Potential in Young People. *Entrepreneurship Theory & Practice*, 33(2): 481-500.
- Avnimelech, G., Zelekha, Y. and Sarabi, E. (2014). The Effect of Corruption on Entrepreneurship in Developed vs Non-Developed Countries, *International Journal of Entrepreneurial Behaviour & Research*, 20(3):237 – 262.
- Ajzen, I. (1985). From Intentions to Actions: A Theory of Planned Behavior. In J. Kuhl, & J. Beckmann, *Action-control: From Cognition to Behavior* (pp. 11-39). Heidelberg: Springer.
- Ajzen, I. (1987). Attitudes, Traits, and Actions: Dispositional Prediction of Behavior in Personality and Social Psychology. In L. Berkowitz, *Advances in Experimental Social Psychology* (pp. 1-63). New York: Academic Press.
- Ajzen, I. (2002). Perceived Behavioral Control, Self-Efficacy, Locus of Control, and the Theory of Planned behavior. *Journal of Applied Social Psychology*, 32, 665-683.
- Ajzen, I. (2005). *Attitudes, Personality and Behavior*. Maidenhead, England; New York: Open University Press.
- Ajzen, I. (2006). *Constructing a TPB Questionnaire: Conceptual and Methodological Considerations*. Retrieved June 27, 2011 from the World Wide Web: <http://www.people.umass.edu/aizen/pdf/tpb.measurement.pdf>
- Ajzen, I. & Fishbein, M. (1980). *Understanding Attitudes and Predicting Social Behavior*. Englewood Cliffs, NJ: Prentice-Hall.
- Ajzen, I. (1991). The Theory of Planned Behavior, *Organizational Behavior and Human Decision Processes*, 50, 179-211.
- Ariff, A.H. M., Bidin, Z., Sharif, Z., and Ahmad, A. (2010). Predicting Entrepreneurship Intention among Malay University Accounting Students in Malaysia”, *Unitar E-Journal* Vol.6, No.1.
- Armitage, C. J., & Conner, M. (2001). Efficacy of the Theory of Planned Behavior: A meta-Analytic Review. *British Journal of Social Psychology*, 40, 471–499.
- Audet, J. (2002). A Longitudinal Study of the Entrepreneurial Intentions of University Students. *Babson Kaufmann Entrepreneurship Research Conference*. Boulder.
- Autio, E., Keeley, R., Klofsten, M., Parker, G., & Hay, M. (2001). Entrepreneurial Intent among Students in Scandinavia and in the USA. *Enterprise and Innovation Management Studies*, 2 (2), 145-160.
- Backman, J. (Ed.) (1983). *Entrepreneurship and the Outlook for America*, The Free Press, New York, NY.

- Bakotic,D., & Kruzic,D., (2010). Students' Perceptions and Intentions towards Entrepreneurship: the Empirical Findings from Croatia. *The Business Review*, Cambridge, Vol. 14, No. 2.
- Bandura, A. (1971). *Social Learning Theory*. New York: General Learning Press.
- Bandura, A. (1982). Self-Efficacy Mechanism in Human Agency. *American Psychologist*, 37 (3), 122-147.
- Bandura, A. (1986). *The Social Foundations of Thought and Action*. Englewood Cliffs, NJ: Prentice-Hall.
- Bandura, A. (1997). *Self-Efficacy: The Exercise of Control*. NY: W.H. Freeman and Company.
- Baron, R.A., & Markman, G.D. (1999). Cognitive Mechanisms: Potential Differences between Entrepreneurs and Non-Entrepreneurs. In P.D. Reynolds, W.D. Bygrave, et al. (Eds.), *Frontiers of entrepreneurship research*. Wellesley, MA: Babson College.
- Baum, J.A.C., T. Calabrese, B.S. Silverman. (2000). Don't Go it Alone: Alliance Network Composition and Startups' Performance in Canadian Biotechnology. *Strategic Management Journal* 21(3) 267-294.
- Baumol, W. (1968). Entrepreneurship in Economic Theory. *The American Economic Review*, Vol. 58, Issue 2, p. 64-71.
- Beaver, G. (2002). *Small Business, Entrepreneurship and Enterprise Development*, Pearson Education, London.
- Bechard, J.-P., and Gregoire, D. (2005). Entrepreneurship Education Research Revisited: The Case of Higher Education. *Academy of Management Learning & Education*, 4(1): 22-43.
- Begley, T. M. & Boyd, D. P. (1987). Psychological Characteristics of Associated with Performance in Entrepreneurial Firms and Small Businesses. *Journal of Business Venturing*, 2: 79-83.
- Bergmann, H., Andrea, J., and Christine, T. (2002). Regionaler Entrepreneurship Monitor (REM) - Gründungsaktivitäten und Rahmenbedingungen in zehn deutschen Regionen. Universität zu Köln and Universität Lüneburg.
- Bernasek, A. and Stephanie. S. (2001). Gender, Risk and Retirement. *Journal of Economic Issues* 35(2): 345 – 56.
- Bird, B. (1988). Implementing Entrepreneurial Ideas: The Case for Intention. *Academy of Management Review*, 13(3): 442-453.
- Blanchflower, D. and Oswald, A. (1998). "What Makes an Entrepreneur?" *Journal of Labor Economics*, 16, 26-60.
- Blanchflower, D. G. (2004). "Self-Employment: More May not be better". *Swedish Economic Policy Review* 11, 2, 15-74.
- Block, Z. & Stump, S.A. (1992). Entrepreneurship Education Research, Experience and Challenge. In Sexton, D.L. & J. Kasarda (Eds.). *The State of the Art in Entrepreneurship*, 17-43, Boston, MA: PWS-Kent.
- Booth, A., Nolen, P. (2012). Gender Differences in Risk Behavior: Does Nurture Matter? *Economic Journal* 122: F56-F78.
- Borghans, L., Golsteyn, B.H.H, Heckman, J.J and Meijers, H. (2009). Gender Differences in Risk Aversion and Ambiguity Aversion. *Journal of the European Economic Association* 7(2-3): 649-658.
- Borjas, G. J. and Bronars, S. G. (1989). Consumer Discrimination and Self-Employment, *NBER Working Papers* 2627, National Bureau of Economic Research, Inc.

- Boyd, R. (1990). Black and Asian Self-Employment in Large Metropolitan Areas: A Comparative Analysis. *Social Problems*, 37(2): 258–274.
- Boyd, N.G. & Vozikis, G. S. (1994). The Influence of Self-Efficacy on the Development of Entrepreneurial Intentions and Actions, *Entrepreneurship Theory & Practice*, 18, 63–63.
- Brice, J. Jnr. (2002). *The Role of Personality Dimensions and Occupational Preferences on the Formation of Entrepreneurial Intentions*. PhD Thesis. Mississippi State University Department of Management and Information Systems.
- British Psychological Society, *Women Leaders Less Likely to Take Risks*, accessed from <http://www.bps.org.uk/news/women-leaders-less-likely-take-risks>
- Brixy, U., Hessels, J., Hundt, C., and Sternberg, R. (2008). Global Entrepreneurship Monitor 2008, the Netherlands. Retrieved from [http://www.osnabrueck.ihk24.de/linkableblob/osihk24/starthilfe/download/1390026/3./data/GEM\\_Laenderbericht\\_Deutschland-data.pdf](http://www.osnabrueck.ihk24.de/linkableblob/osihk24/starthilfe/download/1390026/3./data/GEM_Laenderbericht_Deutschland-data.pdf)
- Brockhaus, R. (1980). Risk Taking Propensity of Entrepreneurs. *Academy of Management Review*, 23, 509-520.
- Brockhaus, S.R. and Horwitz, P. (1986). The Psychology of the Entrepreneur in *The Art and Science of Entrepreneurship*,” D. Sexton and R. Smilor eds.
- Brockner, J. Higgins, T. and Low, M. B. (2004). Regulatory Focus Theory and the Entrepreneurial Process. *Journal of Business Venturing*, 19, 203–220.
- Brüderl, J. & Preisendörfer, P. (1998). Network Support and the Success of Newly Founded Businesses. *Small Business Economics*, 10, 213–225.
- Burch, J.G. (1986). *Entrepreneurship*, John Wiley & Sons, New York, NY.
- Burt, R.S., and Raider, H.J. (2002). Creating Careers: *Women's Paths to Entrepreneurship*. Unpublished manuscript, University of Chicago, Chicago, IL.
- Buttar, H. M. (2015). Formation of an Entrepreneurial Career Intentions: The Role of Socio-Cognitive Factors, *Journal of employment counseling*, Volume 52:1.
- Byabashaija, W., and Katono, I. (2011). The Impact of College Entrepreneurial Education on Entrepreneurial Attitudes and Intention to Start a Business in Uganda. *Journal of Developmental Entrepreneurship*, Vol. 16, no. 1 (2011), pp 127-144.
- Bygrave, W., and Hofer, C. (1991). *Theorizing about Entrepreneurship*. *Entrepreneurship Theory and Practice*, 16(2), 13-22.
- Cheung, C. K. (2008). Practicing Entrepreneurship Education for Secondary Pupils through the Operation of a New Year Stall in Hong Kong. *Asia-Pacific Education Researcher*, 17(1): 15-31.
- Crant, J. M. (1996). The Proactive Personality Scale as a Predictor of Entrepreneurial Intentions, *Journal of Small Business Management*  
[http://www.researchgate.net/profile/J\\_Crant/publication/247954830\\_The\\_proactive\\_personality\\_scale\\_as\\_a\\_predictor\\_of\\_entrepreneurial\\_intentions/links/54495b020cf2f63880820c0c.pdf](http://www.researchgate.net/profile/J_Crant/publication/247954830_The_proactive_personality_scale_as_a_predictor_of_entrepreneurial_intentions/links/54495b020cf2f63880820c0c.pdf)
- Cantillon, R. (1755 (1931)). *Essai Sur la Nature du Commerce en Ge'ne'ral (Essay on the Nature of Trade in General)*. London: Macmillan.
- Carreira, C., and Silva, F. (2010). No Deep Pockets: Some Stylized Empirical Results on Firms' Financial Constraints. *Journal of Economic Surveys*, 24(4), 731-753.
- Carland, J. W., and Carland, J. A. (1997). Entrepreneurship: An American Dream. *Journal of Business and Entrepreneurship*, 9(1): 33–46.

- Casson, Mark C. (1982). *The Entrepreneur: An Economic Theory*, Oxford: Martin Robertson, 2nd. ed. Edward Elgar, 1999.
- Casson, Mark C. (1995). *Studies in the Economics of Trust*, Cheltenham: Edward Elgar.
- Casson, M. (2003). *The Entrepreneur: An Economic Theory*. Northampton MA: Edward Elgar Publishing.
- Casson, M., Yeung, B., Basu, A., and Wadeson, N. (2006). *The Oxford Handbook of Entrepreneurship, Oxford. England*. Oxford University Press, 2006.
- Charney, A. & Libecap, G. (2000). Impact of Entrepreneurship Education, *Insight. A Kauffman Research Series*. 1–8.
- Chen, C. C., Greene, P. G., and Crick, A. (1998). Does Entrepreneurial Self-Efficacy Distinguish? *Journal of Business Venturing*, 13(4): 295.
- Chen, Y., and Linan, F. (2009). Development and Cross-Cultural Application of a Specific Instrument to Measure Entrepreneurial Intentions. *Entrepreneurship Theory and Practice*, 2009, v. 33, n. 3, p. 593-617.
- Chrisman, J. J., McMullanb, E., and Hall, J. 2005. The Influence of Guided Preparation on the Long-Term Performance of New Ventures. *Journal of Business Venturing*, 20: 769-791.
- Churchill, G. (1979). A Paradigm for developing better Measures of Marketing Constructs. *Journal of Marketing Research*, 16, 64-73
- Churchill, N. (1992). Research Issues in Entrepreneurship. In D. Sexton, & J. Kasarda (Eds.). *The State of the Art of Entrepreneurship*, pp. 579-596. Boston MA.
- Ciccone A. and Papaioannou, E. (2006). Red Tape and Delayed Entry. *CEPR Discussion paper No. 5996*.
- Clark, B.W., Davis, C. H. and Harnish, V.C. (1984). Do Courses in Entrepreneurship Aid New Venture Creation? *Journal of Small Business Management*, 22(2), 26-31.
- Cogburn, D.L. and Catherine, N. A. (2000). Exploring the Challenges and Opportunities for Africa in the Information Economy. The United Nations University, *INTECH, Discussion Paper Series*.
- Cole, A.H. (1968). Introductory Remarks. *The American Economic Review* 58/2: 60-63.
- Colombier, N. and Masclat, D. (2008). Intergenerational Correlation in Self-Employment: Some Further Evidence from French ECHP data, *Small Business Economics*, Vol. 30: 423–37.
- Cromie, S. (2000). Assessing Entrepreneurial Inclinations: Some Approaches and Empirical Evidence. *European Journal of Work and Organizational Psychology*, 2000, Vol. 9, No 1, p. 7-30.
- Cromie, S. and Johns, S. (1982). Irish Entrepreneurs: Some Personal Characteristics. *Journal of Occupational Behaviour*, 4, 317-24.
- Cronbach, L. J. (1951). Coefficient Alpha and the Internal Structure of Tests. *Psychometrika*, 16(3), 297-334.
- Cruz, N. M., Escudero, A. I. R., Barahona, J. H., and Leitao, F. S. (2009). The Effect of Entrepreneurship Education Programmes on Satisfaction with Innovation Behaviour and Performance. *Journal of European Industrial Training*, 33(3): 198-214.
- Curran, J., and Stanworth, J. (1989). Education and Training for Enterprise: Some Problems of Classification, Evaluation, Policy and Research. *International Small Business Journal*, 7:11-22.
- David, M.C. (2014). Entrepreneurial Perceptions and Intentions: An Empirical Survey of Students in the Faculty of Commerce at Great Zimbabwe University, Zimbabwe. *International Journal of Management Sciences*, Vol.2 No.1, 2014, 1-11.

- Davidsson, P. (2006). Nascent Entrepreneurship: Empirical Studies and Developments. *Foundations and Trends in Entrepreneurship* Vol. 2: No. 1, pp 1-76.
- Davidsson, P., and Honig, B. (2003). The role of Social and Human Capital among Nascent Entrepreneurs. *Journal of Business Venturing* 18(3):pp. 301-331.
- Delmar, F. and Davidson, P. (2000). Where do they come from? Prevalence and Characteristics of Nascent Entrepreneurs, *Entrepreneurship and regional development* 12, 1-23.
- De Noble AF, Jung D, Ehrlich SB. (1999). Entrepreneurial Self-Efficacy: the Development of a Measure and Its Relationship to Entrepreneurial Action. *In Frontiers of Entrepreneurship Research*, Reynolds P, Bygrave W, Manigart S, Mason C, Meyer G, Sapienza H, Shaver K (eds). Babson College: Babson Park, MA.
- Desai, M., Gompers, P., and Lerner, J. (2003). Institutions, Capital Constraints and Entrepreneurial Firm Dynamics: Evidence from Europe. *NBER Working Paper* no 10165
- De Soto, H. (1999). *The Other Path*. New York, NY: Harper and Row.
- Dethier, J., Hirn, M., & Straub, S. (2011). Explaining Enterprise Performance in Developing Countries with Business Climate Survey Data. *World Bank Research Observer*, 26(2), 258-309.
- DeTienne, D. R., & Chandler, G. N. (2004). Opportunity Identification and Its Role in the Entrepreneurial Classroom: A Pedagogical Approach and Empirical Test. *Academy of Management Learning & Education*, 3(3): 242-257.
- DeVellis, R.F. (1991). "Scale Development: theory and applications," Applied Social Research Methods Series, Vol. 26). Newbury Park: Sage.
- De Vries, H., Dijkstra, M. and Kuhlman, P. (1988). Self-efficacy: the Third Factor besides Attitude and Subjective Norm as a Predictor of Behavioral Intentions. *Health Education Research*, 3, 273-282.
- Ding, W., Fiona, M., and Toby, S. (2013). From Bench to Board: Gender Differences in University Scientists' Participation in Corporate Scientific Advisory Boards. *Academy of Management Journal* 56: 1443-1464.
- Djankov S., La Porta, R., Lopes-de-Silanes och, F. and Shleifer, A. (2002). The Regulation of Entry. *The Quarterly Journal of Economics*, 67 1-37.
- Djankov, S., Tim, G., Caralee, M., Rita, R., and Shleifer, A. (2010). The Effect of Corporate Taxes on Investment and Entrepreneurship. *American Economic Journal: Macroeconomics* 2 (3): 31-64.
- Dominguez-Torres, C. and V. Foster. (2011). *Cameroon's Infrastructure: A Continental Perspective. Africa Infrastructure Country Diagnostic (AICD) Country Report. Africa's Infrastructure: A Time for Transformation Washington, DC: World Bank*, available at <http://www.ppiaf.org/sites/ppiaf.org/files/publication/AICD-Cameroon-Country-Report.pdf>.
- Douglas, E., and Shepherd, D. (2002). Self-employment as a Career Choice: Attitudes, Entrepreneurial Intentions, and Utility Maximization. *Entrepreneurial Theory and Practice* 26(3):pp. 81-90.
- Drnovsek, M., and Erikson, T. (2005). Competing Models of Entrepreneurial Intentions. *Economic and Business Review*, 7 (1), 55-71.
- Drucker, P.F. (1985). *Innovation and Entrepreneurship*, New York, Harper & Row.
- Dugassa T. G. (2012). The Context of Entrepreneurship Education in Ethiopian Universities, *Management Research Review*, Vol. 35 ISS: 3/4, pp.225 – 244.

- Dunn, T. A., & Holtz-Eakin, D. (2000). Financial capital, human capital, and the transition to self-employment: Evidence from intergenerational links. *Journal of Labor Economics*, 18(2), 282–305.
- Eagly, A., & Chaiken, S. (1993). *The Psychology of Attitudes*. Fort Worth: Harcourt Brace College Publisher.
- Ekpoh, U. I., & Edet, A. O., (2011). Entrepreneurship Education and Career Intentions of Tertiary Education Students in Akwa Ibom and Cross River States, Nigeria. *International Education Studies* 4: (1), 172
- Emmanuel, E, A. Dazala, I. U. and Daniel, J. D. (2012). Entrepreneurship Education and Attitude of Undergraduate Students to Self- Employment in Mubi, Adamawa State, Nigeria. *Journal of Education and Practice*. 3: (8).
- Escribano, A., Guasch, L.J., and Pena, J. (2009). Assessing the Impact of Infrastructure Quality on Firm productivity in Africa. Departamento de Economía, Universidad Carlos III de Madrid, *Working Paper* 09-86.
- European Commission. (2012). *Entrepreneurship Education at School in Europe: National Strategies, Curricula and Learning Outcomes*, [http://eacea.ec.europa.eu/education/Eurydice/documents/thematic\\_reports/135EN.pdf](http://eacea.ec.europa.eu/education/Eurydice/documents/thematic_reports/135EN.pdf)
- Ely, R., & Hess, R. (1949). *The Entrepreneur and Economic Theory: A Historical and Analytical Approach*. Paper presented at the American Economic Review.
- European Commission. (2003). Entrepreneurship in Europe. *Green Paper*, Brussels, 21.1.2003.
- Evans, J. G. (1949). The Entrepreneur and Economic Theory: a Historical and Analytical Approach. *The American Economic Review*, 39, 336-348.
- Evans and Leighton. (1990). Revisiting the Determinants of Entrepreneurship: A Bayesian Approach. *Journal of Management*, 41:607-631
- Evans, D. and B. Jovanovic. (1989). “An Estimated Model of Entrepreneurial Choice under Liquidity Constraints”. *Journal of Political Economy*, 97, 808-827.
- Everitt, B.S. (2002). *The Cambridge Dictionary of Statistics*. 2. Cambridge, UK: Cambridge University Press.
- Fadahunsi, A. and Rosa, P. (2002). Entrepreneurship and Illegality: Insights from the Nigerian Cross-Border Trade. *Journal of Business Venturing*, 17(5), 397–429.
- Fairlie R and Marion, J. (2010). Affirmative Action Programs and Business Ownership among Minorities and Women. *Small Business Economics*, September 2012, Volume 39, Issue 2, pp 319-339.
- Fatoki, O. (2014). The Entrepreneurial Intention of Undergraduate Students in South Africa: The Influence of Entrepreneurship Education and Previous Work Experience. *Mediterranean Journal of Social Sciences*, vol5 No.7.
- Fayolle, A. (2000). Exploratory Study to Assess the Effects of Entrepreneurship Programs on French Student Entrepreneurial Behaviors. *Journal of Enterprising Culture* 8, 169–184.
- Fayolle, A., Gailly, B., Lassas-Clerc, N. (2006). Assessing the Impact of Entrepreneurship Education Programmes: a New Methodology. *Journal of European Industrial Training* 30, 701–720.
- Fayolle A. (2009). *Entrepreneurship Education in Europe: Trends and Challenges, OECD LEED Programme, universities, innovation and entrepreneurship*. Good Practice Workshop. Available: <http://www.oecd.org/dataoecd/11/36/43202553.pdf>.
- Federal Negarit Gazeta of the Federal Democratic Republic of Ethiopia, Addis Ababa, April 3, 1998, 4th Year No. 32. Accessed from



- <http://www.fsc.gov.et/resources/Negarit%20Gazeta/Gazeta-1990/Reg%20No.%2033-1998%20Micro%20and%20Small%20Enterprises%20Development%20Age.pdf>
- Feather, N. T. (1982). Expectancy-value Approaches: Present Status and Future Directions. In Feather, N. T. (ed.), *Expectations and Actions: Expectancy-Value Models in Psychology*, Erlbaum, Hillsdale, NJ.
- Federal Democratic Republic of Ethiopia, *Growth and Transformation Plan 2010/11-2014/15*. Accessed from <http://planipolis.iiep.unesco.org/upload/Ethiopia/EthiopiaGTP.pdf>.
- Field, A and Miles, J. (2010). *Discovering Statistics Using SAS*. London, SAGE Publications Ltd.
- Festinger, L. (1957). *A Theory of Cognitive Dissonance*. Stanford, CA: Stanford University Press.
- Field, A. P. (2005). *Discovering Statistics using SPSS*. London: Sage.
- Fini R., Grimaldi, R., Marzocchi, G.L., Sobrero, M. (2009). *The Foundation of Entrepreneurial Intention*. Research seminars, 27th February 2009, Center for Strategic Management and Globalization at Copenhagen Business School, Copenhagen, Denmark;
- Fishbein, M., Ajzen, I. (1975). *Belief, Attitude, Intention and Behaviour: An Introduction to theory and Research*. Reading, MA: Addison-Wesley
- Fishbein, M. (1993). Introduction, In: The Theory of Reasoned Action: Its Application to AIDS-Protective Behavior, D. J. Terry, C. Gallois & M. McCamish (Eds.), *Oxford: Pergamon*, xv-xxv
- Fisman, R. and Svensson, J. (2007). Are Corruption and Taxation really Harmful to Growth? Firm Level Evidence. *Journal of Development Economics*, 83(1): 63-75.
- Frank, N. and Lüthje, C. (2004). Entrepreneurial Intentions of Business Students: A Benchmarking Study. *International Journal of Innovation and Technology Management*, 1(3), 269–288.
- Friedrich, C., Glaub, M., Gramberg, K., and Frese, M. (2006). Does Training Improve the Business Performance of Small-Scale Entrepreneurs? An Evaluative Study. *Industry and Higher Education*, 20(2): 75-84.
- Galloway, L., Anderson, M., Brown, W., and Wilson, L. (2005). Enterprise Skills for the Economy. *Education + Training*, 47(1): 7-17.
- Galloway, L., and Brown, W. (2002). Entrepreneurship Education at University: a Driver in the Creation of High Growth Firms? *Education + Training*, 44(8/9): 398 - 405.
- Garavan, T.N., & O' Cinneide, B. (1994). Entrepreneurship Education and Training programmes: A review and Evaluation-Part 1. *Journal of European Industrial Training*, 18(8), 3-13.
- Garba,A.S, Kabir,S., and Nalado, A.M. (2014). An Assessment of Students' Entrepreneurial Intentions in Tertiary Institution: A Case of Kano State Polytechnic, Nigeria. *International Journal of Asian Social Science*, 2014, 4(3): 434-443
- Gartner, W B. (1985). A Conceptual Framework for Describing the Phenomenon of New Venture Creation. *The Academy of Management Review*, 10(4): 696-706.
- Gartner, W.B. (1988). Who is an Entrepreneur? Is the Wrong Question. *American Journal of Small Business*, 12, 4, 11-32.
- Gartner, W. B. (1990). What are We Talking about When We Talk about Entrepreneurship? *Journal of Business Venturing*, 5(1), 15-28.

- Gaston, G., and Gerjo, K. (1996). The Theory of Planned Behavior: A Review of Its Applications to Health-related Behaviors. *American Journal of Health Promotion*, Vol. 11, No. 2, pp. 87-98.
- Gedeon, S. (2010). What is Entrepreneurship? *Entrepreneurial Practice Review*, Volume 1 Issue 3.
- Gentry, W., and Hubbard, G. (2000). Tax Policy and Entrepreneurial Entry. *American Economic Review*, 90, 283-287.
- Getachew, A., and Tigro, Y. (2012). Entrepreneurship Education: An Assessment of its Effect on Entrepreneurial Intentions (A Case of Public Universities' Students in Ethiopia). *International Journal of Multidisciplinary Research* Vol.2 Issue 12.
- Ghazali, Z., Ibrahim, N.A., & Zainol, A.F. (2013). Factors Affecting Entrepreneurial Intention among UniSZA Students. *Asian Social Science*; Vol. 9, No. 1.
- Gibcus, P., de Kok, J., Snijders, J., Smit, L., and van der Linden, B. (2012). *Effects and Impact of Entrepreneurship Programmes in Higher Education*. Report prepared for the European Commission, DG Enterprise and Industry.
- Gird, A., and Bagraim, J. (2008). The Theory of Planned Behaviour as Predictor of Entrepreneurial Intent amongst Final-Year University Students. *South Africa Journal of Psychology*, 38(4), 711-724.
- Global Entrepreneurship Monitor, (2012), Global Report, <http://www.gemconsortium.org/docs/download/2645>
- (2009) Global Report, <http://www.gemconsortium.org/docs/download/265>
- GEM Uganda 2010 executive Report, <http://www.gemconsortium.org/docs/download/644>
- Goffee, R., and Scase, R. (eds.) (1987). *Entrepreneurship in Europe*. The Social Processes. London: Croom Helm, 1987.
- Golla, S., Halter, F., Fueglistaller, U., Klandt, H. (2006). Gründungsneigung Studierender - Eine empirische Analyse in Deutschland und der Schweiz. In: Achleitner, A., Klandt, H., Koch, L. T., Voigt, K. (Eds.): *Jahrbuch Entrepreneurship 2005/2006*. Gründungsforschung und Gründungsmanagement. Berlin, S. 209-237.
- Grilo, I. and Thurik, A. R. (2006). Entrepreneurship in the Old and the New Europe, in: E. Santarelli (ed), *Entrepreneurship, Growth and Innovation*, Berlin: Springer Verlag, 75-103.
- Gottlieb, E. and Ross, J.A. (1997). Made not Born: HBS Courses and Entrepreneurial Management. *Harvard Business School Bulletin*, Vol. 73 February, pp. 41-5.
- Hair, Jr., J.F., Black, W.C., Babin, B.J., Anderson, R.E., Tatham, R.L. (2006). *Multivariate Data Analysis* (6th Ed.), Pearson-Prentice Hall, Upper Saddle River, NJ.
- Hansemark, O. C. (1998). The Effects of an Entrepreneurship Programme on Need for Achievement and Locus of Control of Reinforcement. *International Journal of Entrepreneurial Behaviour and Research*, 4: 28-50.
- Harper, D. (1997). Institutional Conditions for Entrepreneurship. *Working paper*, New York University, USA.
- Harris, M., Gibson, S., & Taylor, S. (2008). Examining the Impact of Small Business Institute Participation on Entrepreneurial Attitudes. *Journal of Small Business Strategy*, 18(2): 113-129.
- Hart, D.M. (2003). Entrepreneurship Policy: What It Is and Where It Came from in Hart, D.M. (ed.) *The Emergence of Entrepreneurship Policy: Governance, Start-ups and Growth in the US Knowledge Economy*. Cambridge: Cambridge University Press: 3-19.

- Hawley, F. (1907). *Enterprise and the Productive Process*. New York, NY: Putnam.
- Hattab, H. (2014). Impact of Entrepreneurship Education on the Entrepreneurial Intentions of University Students in Egypt. *Journal of Entrepreneurship*, vol. 23 no. 1 1-18
- Herron, L. and Robinson, R.B. (1993). A Structural Model of the Effects of Entrepreneurial Characteristics on Venture Performance. *Journal of Business Venturing*, 8, 281-294.
- Hébert, R F & A N Link. (1988). *The Entrepreneur: Mainstream Views and Radical Critiques*. New York, USA: Praeger.
- Henley, A. (2005). Job Creation by the Self-Employed: the Roles of Entrepreneurial and Financial Capital. *Small Business Economics*, Volume 25, Issue 2, pp 175-196.
- Henry, C., Hill, F., Leitch, C. (2003). *Entrepreneurship Education and Training*, Ashgate, Aldershot.
- Hessels, J., Suddle, K and Mooibroek, M. (2008). *Global Entrepreneurship Monitor 2007*. The Netherlands, Zoetermeer: EIM.
- Hosseini, S. M., Hosseini, S. J. F. and Soleimanpour, M.R. (2010). Factors Affecting Student's Entrepreneurship in Agricultural Colleges of Tehran Province. *Iranian Journal of Agricultural Extension and Education*, 5(2): 101- 111.
- Higgins, E.T. (2005). Value from Regulatory Fit. *Current directions in Psychological Science*, 14(4), pp. 209-213.
- Hitt, M.A., Ireland, R.D., Camp, S.M. and Sexton, D.L. (2001). Entrepreneurial Strategies for Wealth Creation. *Strategic Management Journal*, 22: 479-91.
- Hisrich and Peters. (1989). *Entrepreneurship: Starting, Developing, and Managing a New Enterprise*. Homewood, IL: Richard D. Irwin.
- Holtz-Eakin, D., Joulfaian, D., and Rosen, H., (1994). Entrepreneurial Decisions and Liquidity Constraints. *Rand Journal of Economics*, 108, 604-631.
- Hornaday, J.A. and Vesper, K. (1982). Entrepreneurial Education and Job Satisfaction, edited by K. Vesper et al., *Frontiers of Entrepreneurship Research*, Babson University Press., pp.526-567.
- Hoselitz, Bert, F. (1960). Entrepreneurship and Economic Growth. *Sociological Aspects of Economic Growth*, Vol., p. 139-158 1960
- Hubbard, R. (1998). Capital-Market Imperfections and Investment. *Journal of Economic Literature*, Vol. 36, No. 1 (March 1998), pp. 193-225.
- Huda, N., Rini, N., Mardoni, Y., and Putra, P. (2012). The Analysis of Attitudes, Subjective Norms, and Behavioral Control on Muzakki's intention to pay Zakah. *International Journal of Business*, 3, 22/ Special Issues.
- Hull, D L., Bosley, J.J. and Udell, G.G. (1980). Renewing the Hunt for the Heffalump: Identifying Potential Entrepreneurs by Personality Characteristics. *Journal of Small Business*, 18, 11-18.
- Hussain, A. (2015). Impact of Entrepreneurial Education on Entrepreneurial Intentions of Pakistani Students. *Journal of Entrepreneurship and Business Innovation* Vol 2, No 1.
- ILO. (2010). *Tracer Studies on the Know About Business Entrepreneurship Education Programme*. A Synthesis Report from Eight Studies.
- Iakovleva, T. and Kolvereid, L. (2009). An Integrated Model of Entrepreneurial Intentions in the Russian context. *International Journal of Business and Globalisation*, V.3, N2: 66-80.

- Interman. (1992). International Management Development Network in Cooperation with the United Nations Development Program (UDP) and the International Labor Office (ILO). Networking for Entrepreneurship Development, Geneva: International Labor Office.
- Ireland, R. D., Hitt, M.A, and Sirmon, D.G. (2003). A Model of Strategic Entrepreneurship: The Construct and its Dimensions. *Journal of Management*, vol. 29 no. 6 963-989.
- Izquierdo, E. and Buelens, M. (2011). Competing Models of Entrepreneurial Intentions: The Influence of Entrepreneurial Self-Efficacy and Attitudes. *International Journal of Entrepreneurship and Small Business*, 13, 75-91.
- Izedonmi, F.P and Okafor, C. (2010). The Effect of Entrepreneurship Education on Students Entrepreneurial Intention. *Global Journal of Management and Business Research*, 10(6), 49-60
- Jack, S.L., Anderson, A.R. (2002). The Effects of Embeddedness on the Entrepreneurial Process *Journal of Business Venturing*. 17, 5, p. 467-487.
- Jamieson, I. (1984). Schools and Enterprise, in Watts, A.G. and Moran, P. (Eds). *Education for Enterprise*, CRAC, Ballinger, Cambridge: 19-27.
- Jenner, C. (2012). Business and Education: Powerful Social Innovation Partners. *Stanford Social Innovation Review* (Aug. 27, 2012).
- Johannisson, B. (1991). University Training for Entrepreneurship: A Swedish Approach. *Entrepreneurship and Regional Development* 3(1): 67-82.
- Johansson, E. (2000). Self-Employment and Liquidity Constraints: Evidence from Finland. *Scandinavian Journal of Economics*. 102 (1): 123-134.
- Jolanda, H.J., van Gelderen, M., and Thurik, R. (2008). Entrepreneurial Aspirations, Motivations, and their Drivers. *Small Business Economics* 31(3): 323-339.
- Jones, P., Jones, A., Packham, G., & Miller, C. (2008). Student Attitudes towards Enterprise Education in Poland: a Positive Impact. *Education + Training*, 50 (7): 597 - 614.
- Juma, C., (2011). *The New Harvest: Agricultural Innovation in Africa*. Oxford University Press.
- Kabongo, J. (2008). The Status of Entrepreneurship Education in Colleges and Universities in Sub-Saharan Africa. *International Journal of Entrepreneurial Behavior & Research*, 16(4).
- Kaijage, E. and Wheeler, D. (2013). *Supporting Entrepreneurship Education in East Africa*. Report for Presentation to Stakeholders.
- Kaijun, Y., and Sholihah, P.C. (2015). A Comparative Study of the Indonesia and Chinese Educative Systems Concerning the Dominant Incentives to Entrepreneurial Spirit (desire for a new venturing) of business school students. *Journal of Innovation and Entrepreneurship*,4(1).
- Kaish, S., and Gilad, B. (1991). Characteristics of Opportunities Search of Entrepreneurs versus Executives: Sources, Interests and General Alertness. *Journal of Business Venturing*, 6, 45-61.
- Kannan, A.S. (2012). Entrepreneurial Education in Ethiopian Universities, Current Trends and Gaps: the Case of Dilla University. *International Journal of Management (IJM)*, 3(3):121-130.
- Kanbur, S.M. (1979). Of Risk-Taking and the Personal Distribution of Income. *Journal of Political Economy*, 87(4): 769-97.
- Karimi, S., Biemans, H., Lans, T., Mulder, M., Chizari, M. (2012). *The Role of Entrepreneurship Education in Developing Students' Entrepreneurial Intentions*. Proceedings of WICaNeM

- 2012, The 10th Wageningen International Conference on Chain and Network Science, Wageningen University, Wageningen, The Netherlands, p. 22.
- Katz, J. (1992). A Psychological Cognitive Model of Employment Status Choice. *Entrepreneurship Theory and Practice*, 17 (1), 29-37.
- Katz, J.A. (2003). The chronology and Intellectual Trajectory of American Entrepreneurship Education. *Journal of Business Venturing* 18(2): 283-300.
- Kautonen T., Tornikoski, T., Kilber, E. (2011). Entrepreneurial Intentions in the Third Age: the Impact of Perceived Age Norms. *Small Business Economics* Vol. 37.
- Kautonen, T., Luoto, S., and Tornikoski, E.T. (2010). Influence of Work History on Entrepreneurial Intentions in ‘Prime Age’ and ‘Third Age’: A Preliminary Study. *International Small Business Journal*, 28(6), 583-601.
- Kautonen, T., van Gelderen, M. and Tornikoski, E.T. (2013). Predicting Entrepreneurial Behaviour: A Test of the Theory of Planned Behaviour. *Applied Economics*, 45:6, 697-707
- Kelley, D., Brush, C., Greene, P., and Litovsky, Y., (2011). GEM 2010 Report: Women Entrepreneurs Worldwide. *Global Entrepreneurship Monitor*.
- Kets de Vries, M. (1996). The Anatomy of the Entrepreneur, *Human Relations*, 49, 853- 84.
- Kibler, E., Wainwright, T., Kautonen, T., and Blackburn, R. A. (2012), *(Work) Life After Work?: Older entrepreneurship in London-Motivations and Barriers*. Kingston University, Small Business Research Centre, London.
- Kim, M.S. and Hunter, J. (1993). Relationships among Attitudes, Behavioural Intentions, and Behaviour, *Communication Research*, 20, 331-364.
- Klandt, H. (2004). Entrepreneurship Education and Research in German- Speaking Europe. *Academy of Management*, vol.3, 3: 293-301.
- Klapper, L, Laeven, L., and Rajan, R. (2006). Entry Regulation as a Barrier to Entrepreneurship. *Journal of Financial Economics*, Vol. 82, 3:591-629.
- Kline, P. (1999). *The Handbook of Psychological Testing (2nd ed.)* London: Routledge
- Kirzner, I.M. (1973). *Competition and Entrepreneurship*. Chicago: University of Chicago Press.
- Kirzner, I.M. (1985). *Discovery and the Capitalist Process*. Chicago and London, University of Chicago Press.
- Knight, F.H. (1921). *Risk, Uncertainty and Profit*. New York: Harper and Row.
- Knight, F H. (1942). Profit and Entrepreneurial Functions. *The Journal of Economic History*. Vol. 2 Supplement: The Tasks of Economic History: 126-132.
- Koellinger, P., Minniti, M. and Schade, C. (2013). Gender Differences in Entrepreneurial Propensity. *Oxford Bulletin of Economics and Statistics*, 75: 213–234.
- Koller, R. (1988). On the Source of Entrepreneurial Ideas. In B. A. Kirchoff, W. Long, W. McMullen, K. H. Vesper & W. Wetzels (Eds.), *Frontiers of Entrepreneurship Research* (pp. 194-207). Babson Park, US: Babson College.
- Kolvereid, L., and Isaksen, E. (2006). New Business Start-up and Subsequent Entry into Self-Employment. *Journal of Business Venturing*, 21 (6), 866-885.
- Kolvereid, L., and Moen, O. (1997). Entrepreneurship among Business Graduates: Does a Major in Entrepreneurship Make a Difference? *Journal of European Industrial Training*, 21(4/5): 154-160.

- Kourilsky, M.L. (1995). *Entrepreneurship Education: Opportunity in Search of Curriculum*, Center for Entrepreneurial Leadership, Ewing Marion Kauffman Foundation, Kansas City, MO.
- Kourilsky, M. L., and Esfandiari, M. (1997). Entrepreneurship Education and Lower Socioeconomic Black Youth: An Empirical Investigation. *The Urban Review*, 29(3): 205-215.
- Krueger, N. (2000). The Cognitive Infrastructure of Opportunity Emergence. *Entrepreneurship Theory & Practice*, 24(3), 5-23.
- Krueger, N. 1993. The Impact of Prior Entrepreneurial Exposure on Perceptions of New Venture Feasibility and Desirability. *Entrepreneurship: Theory & Practice*, 18(1): 5-21.
- Krueger, N., and Carsrud, A. (1993). Entrepreneurial Intentions: Applying the Theory of Planned Behavior. *Entrepreneurship and Regional Development*, 5, 315–330.
- Krueger N.F.J., Reilly, M.D. and Carsrud A.L. (2000). Competing Models of Entrepreneurial Intentions. *Journal of Business Venturing*, 15(5): 411-432.
- Krueger, N. J., & Brazeal, D. (1994). Entrepreneurial Potential and Potential Entrepreneurs. *Entrepreneurship Theory and Practice*, 18 (3), 91-104.
- Kuratko, D. F. (2005). The Emergence of Entrepreneurship Education: Development, Trends, and Challenges. *Entrepreneurship Theory and Practice*, 29 (5), 577-598.
- Küttim, M., Kallastea, M., Venesaara, U., and Kiis, A. (2014). Entrepreneurship Education at University Level and Students' Entrepreneurial Intentions. *Procedia - Social and Behavioral Sciences* 110(2014) 658- 668
- Lazear, E. P. (2002). *Entrepreneurship*. National Bureau of Economic Research Working Paper 9109.
- Lazear, E.P. (2004). *Balanced Skills and Entrepreneurship*. American Economic Review, Papers and Proceedings, May 2004.
- Lauxen-Ulbrich, M., and Leicht, R. (2003). *First Statistical Overview - National Report on Women (Start-up) Entrepreneurs and Female Self-employed in Germany*. Small Business Research Institute, University of Mannheim, mimeo.
- Lee, D.Y. and Tsang, E.W.K. (2001). The Effects of Entrepreneurial Personality, Background and Network Activities on Venture Growth. *Journal of Management Studies*, 38 (4), 583–602.
- Lee, S. M., Chang, D., and Lim, S.B. (2005). Impact of Entrepreneurship Education: A Comparative Study of the U.S. and Korea. *International Entrepreneurship and Management Journal*, 1(1): 27-43.
- Leffel, A. and Darling, J. (2009). Entrepreneurial versus Organizational Employment Preferences: A Comparative study of Europe and American respondents. *Journal of Entrepreneurship Education* (2009), p. 12.
- Leibenstein, H. (1968). Entrepreneurship and Development. *American Economic Review*, May, 72-83.
- Lent, R., Brown, S., and Hackett, G. (1994). Toward a Unifying Social Cognitive Theory of Career and Academic Interest, Choice, and Performance. *Journal of Vocational Behavior*, 45, 79-122.

- Lepoutre, J., Van Den Berghe, W., Tilleuil, O., and Crijns, H. (2010). A New Approach to Testing the Effects of Entrepreneurship Education among Secondary School Pupils. *Vlerick Leuven Gent Working Paper Series 2010/01*. Vlerick Leuven Gent Management School.
- Lewis, K. (2002). *An Enterprising Future: Evaluating the Young Enterprise Scheme*. Enterprise New Zealand Trust  
[http://sme-centre.massey.ac.nz/files/Complete\\_final\\_ENZT\\_report.pdf](http://sme-centre.massey.ac.nz/files/Complete_final_ENZT_report.pdf)
- Liao, C., Lin, H.N., and Liu, Y.P. (2010). Predicting the Use of Pirated Software: A Contingency Model Integrating Perceived Risk with the Theory of Planned Behaviour. *Journal of Business Ethics*, 91: 237-252
- Libecap, G. (1993). *Contracting for Property Rights*. Cambridge: Cambridge University Press, 1993.
- Li, J. (2008). *The Evolution of Entrepreneurial Intention in Transition Environment: toward an Entrepreneurial Self-Efficacy based Model*. Retrieved November 7, 2011, from IEEEExplore:<http://ieeexplore.ieee.org/stamp/stamp.jsp?tp=&arnumber=4679344>.
- Lim, H. and Dubinsky, A. J. (2005). The Theory of Planned Behavior in E-Commerce: Making a Case for Interdependencies between Salient Beliefs. *Psychology and Marketing*, Vol. 22 No. 10, pp. 833-55.
- Linán, F. (2004). Intention-Based Models of Entrepreneurship Education, *Piccola Impresa/Small Business*, 3, pp. 11–35.
- Liñán, F. and Chen, Y.W. (2006). *Testing the Entrepreneurial Intention Model on a Two-Country Sample*, Document de Treball Num. 06/7, Departament d' Economia de l'Empresa.
- Linan, F., and Chen, Y. W. 2009. Development and Cross-Cultural Application of a Specific Instrument to Measure Entrepreneurial Intentions. *Entrepreneurship Theory and Practice*, 33(3): 593-617.
- Liñán, F., Rodríguez-Cohard, J. C., and Rueda-Cantuche, J. M. (2011). Factors Affecting Entrepreneurial Intention Levels: A Role for Education. *International Entrepreneurship and Management Journal*, 7(2), 195-218.
- Linán, Z., Picot, G. and Compton, J. (2000). The Entry and Exit Dynamics of Self-Employment in Canada, *Small Business Economics* 15 (2), 105-125.
- Liñán, F., and Santos, F. J. (2007). Does Social Capital Affect Entrepreneurial Intentions? *International Advances in Economic Research*, 13(4), 443–453.
- Lindgren, M., and Packendorf, J., (2010) Quadruple Helix reports 2010:5 The gender and entrepreneurship gap in Estonia, Finland and Sweden Accessed from <http://www.diva-portal.org/smash/get/diva2:459304/FULLTEXT01.pdf>
- Locke, E.A., and Latham, G.P. (1990). *A Theory of Goal Setting and Task Performance*. Englewood Cliffs, NJ: Prentice-Hall.
- Lorz, M. (2011). *The Impact of Entrepreneurship Education on Entrepreneurial Intention*. Dissertation of the University of St. Gallen, School of Management, Economics, Law, Social Sciences and International Affairs.  
<http://edudoc.ch/record/107284/files/zu13059.pdf> (27.06.2013).
- Latham, G. P. (2003). Goal setting: A Five-Step Approach to Behavior Change. *Organizational Dynamics*, 32(3), 309-318.
- Loucks, K. (1988) in Peterson, R., Peterson, M.A. and Tieken, N.B., *Encouraging Entrepreneurship Internationally*, Kendall Hunt, Dubuque, Iowa, pp.13, 14.

- Lumpkin, G.T, and Dess, G.G. (1996). Clarifying the Entrepreneurial Orientation Construct and Linking It to Performance. *The Academy of Management Review*, 21(1): 135-72.
- Lundström, A., and Stevenson, L. (2005). *Entrepreneurship Policy: Theory and Practice*. New York: Springer Science+Business Media.
- Lüthje, C., and Franke, N. (2003). The Making of an Entrepreneur: Testing a Model of Entrepreneurial Intent among Engineering Students at MIT. *R&D Management*, 33(2): 135.
- Maddala, G. S. (1983). *Limited-Dependent and Qualitative Variables in Economics*. New York: Cambridge University Press.
- Malebana, M.J. & Swanepoel, E. (2014). The Relationship between Exposure to Entrepreneurship Education and Entrepreneurial Self-Efficacy. *Southern African Business Review*, 18(1), 1-26.
- Malebana, M.J (2014). Entrepreneurial Intentions of South African Rural University Students: A Test of the Theory of Planned Behavior. *Journal of Economics and Behavioral Studies*, Vol. 6, No. 2, pp. 130-143.
- Mambula, C. (2002). Perceptions of SME Growth Constraints in Nigeria, *Journal of Small Business Management*, 40(1), pp. 58-65.
- Marshall, A. (1890). *Principles of Economics*, London: Macmillan.
- Martin, S. (1991). *Learned Optimism: How to Change Your Mind and Your Life*. New York: Knopf.
- Maas, C.J.M., and Hox, J.J. (2005). Sufficient Sample Sizes for Multilevel Modeling. *Methodology* 2005; Vol. 1(3):86–92
- Matlay, H. (2008). The Impact of Entrepreneurship Education on Entrepreneurial Outcomes. *Journal of Small Business and Enterprise Development*, 15(2): 382-396.
- Max Weber, P., and Schaper, M. T. (2004). Understanding the Grey Entrepreneur. *Journal of Enterprising Culture*, 12(2), 147 - 164 (1904/1970) on society and economic development.
- Mesch, G. S., and Czamanski, D. (1997). Occupational Closure and Immigrant Entrepreneurship: Russian Jews in Israel. *Journal of Socio-Economics*, 26(6): 597-611.
- McClelland, D. (1961). *The Achieving Society*. Princeton, NJ: Van Nostrand.
- McCracken, K., Marquez, S., Kwong,C., Stephan,U., Castagnoli, A., and Dlouhá,M. (2015). *Women's Entrepreneurship: Closing the Gender Gap in Access to Financial and Other Services and in Social Entrepreneurship*, European Parliament manuscript completed in June 2015.
- McGrath, R. (2003). Connecting the Study of Entrepreneurship and Theories of Capitalist Progress: An Epilogue in Handbook of Entrepreneurship Research: *An Interdisciplinary Survey and Introduction*, edited by Zoltan Acs and David Audretsch. Boston: Kluwer Academic Publishers.
- MacMillan, I. C., and Katz, J. A. (1992). Idiosyncratic Milieus of Entrepreneurial Research: The Need for Comprehensive Theories. *Journal of Business Venturing*, 7, 1-8.
- McMillan, J., and Woodruff, C. (2002). The Central Role of Entrepreneurs in Transitional Economies. *Journal of Economic Perspectives* 16 (3), 153–170.
- McMullan, W., Chrisman, J.J., and Vesper, K. (2001). Some Problems in Using Subjective Measures of Effectiveness to Evaluate Entrepreneurial Assistance Programs. *Entrepreneurship Theory and Practice* 26(1): 37-54



- Mescon, T., and Montanari, J. (1981). The Personalities of Independent and Franchise Entrepreneurs: An Empirical Analysis of Concepts. *Journal of Enterprise Management*, 3(2), 149-159.
- Minitti, M., and Arenius, P. (2003). Women in Entrepreneurship. Paper presented at *The Entrepreneurial Advantage of Nations: First Annual Global Entrepreneurship Symposium*, United Nations Headquarters, April 29, 2003.
- Mitchell, L. (2011). *Overcoming the Gender Gap: Women Entrepreneurs as Economic Drivers*. Report, Ewing Marion Kaufman Foundation. Can be accessed at: [http://www.kauffman.org/uploadedFiles/Growing\\_the\\_Economy\\_Women\\_Entrepreneurs.pdf](http://www.kauffman.org/uploadedFiles/Growing_the_Economy_Women_Entrepreneurs.pdf)
- Montgomery, D. C., Peck, E. A., Vining, G. G. (2001). *Introduction to Linear Regression Analysis*. 3rd edition, Wiley, New York.
- Moriano, J.A., Gorgievski, M., Laguna, M., Stephan, U., and Zarafshani, K. (2011). Understanding Entrepreneurial Intention: A Cross Cultural Approach to Understanding Entrepreneurial Intention *Journal of Career Development*, doi: 10.1177/0894845310384481
- Morris M.H. (1998). *Entrepreneurial Intensity: Sustainable Advantage for Individuals, Organizations and Societies*. Quorum, Westport: CT.
- Mudde, H.L.M, Gerba, D.T, and Chekol, A.D. (2015). Entrepreneurship Education in Ethiopian Universities: Institutional Assessment, Synthesis Report. *Working Paper No. 2015/01*, <http://www.msm.nl/resources/uploads/2015/11/MSM-WP2015-01.pdf>.
- Muofhe, N.J. and Du Toit, W. (2011). Entrepreneurial Education's and Role Models' Influence on Career Choice', *South African Journal of Human Resource Management*, 9(1): Art. #345.
- Musso, P., and Schiavo, S. (2008). The Impact of Financial Constraints on Firm Survival and Growth. *Journal of Evolutionary Economics*, 18(2), 135-149.
- Mwaslwiba, E. (2010). Entrepreneurship Education: A Review of its Objectives, Teaching Methods, and Impact Indicators. *Education+ Training*, 52(1), 20-47.
- Nasr, B.K, and Boujelbene, Y. (2014). *Assessing the Impact of Entrepreneurship Education*. 2nd World Conference on Business, Economics and Management, Volume 109, 8 January 2014, Pages 712–715
- Niesbud (2013). *Entrepreneurship in Africa: Lack of Capital & Funds*, accessed on December 2/2014 from <http://onlineniesbud.blogspot.it/2013/09/entrepreneurship-in-africa-lack-of.html>.
- Nunnally, J. C. (1978). *Psychometric theory (2nd ed.)* New York: McGraw-Hill.
- Nyström, K. (2008). The Institutions of Economic Freedom and Entrepreneurship: Evidence from Panel Data. *Public Choice*, Vol 136, 3-4:269-282.
- OECD (1998). *Fostering Entrepreneurship*, Paris: OECD.
- OECD (2009). *Evaluation of Programmes Concerning Education for Entrepreneurship*, report by the OECD Working Party on SMEs and Entrepreneurship, OECD.
- OECD (2011). How Does Education Affect Employment Rates? in *Education at a Glance 2011: Highlights*, OECD Publishing. [http://dx.doi.org/10.1787/eag\\_highlights-2011-16-en](http://dx.doi.org/10.1787/eag_highlights-2011-16-en)
- OECD (2012) *Education Indicators in Focus*, <http://www.oecd.org/education/skills-beyond-school/49471658.pdf>.
- O'Gorman, C., Cunningham, J. (1997). *Enterprise in Action—an Introduction to Entrepreneurship in an Irish Context*, Oak Tree Press, Dublin.

- Ohland, M. W., Frillman, S. A., Zhang, G., Brawner, C. E., and Miller Iii, T. K. (2004). The Effect of an Entrepreneurship Program on GPA and Retention. *Journal of Engineering Education*, 93(4): 293-301.
- Olomi, D., and Sinyamule, R. (2009). Entrepreneurial Inclinations of Vocational Education Students: A Comparative Study of Male and Female Trainees in Iringa Region, Tanzania. *Journal of Enterprising Culture*, 17(1): 103.
- Omidyar Network. (2013). *Understanding Africa's Challenges to Creating Opportunity-Driven Entrepreneurship*. Accessed on November 15/2013 from [http://www.omidyar.com/sites/default/files/file/ON%20Africa%20Report\\_April%202013\\_Final.pdf](http://www.omidyar.com/sites/default/files/file/ON%20Africa%20Report_April%202013_Final.pdf).
- Oosterbeek, H., Van Praag, M. and IJsselstein, A. (2010). The Impact of Entrepreneurship Education on Entrepreneurship Skills and Motivation. *European Economic Review*, 54(3), 442–454.
- Oviatt, B.M., McDougall, P.P. (2005). Defining International Entrepreneurship and Modeling the Speed of Internationalization. *Entrepreneurship Theory and Practice*, 29(5), 537–553.
- Palich, L. and Bagby, D. (1995). Using Cognitive Theory to Explain Entrepreneurial Risk taking: Challenging Conventional Wisdom, *Journal of Business Venturing*, 10, 425-438.
- Palmer, M. (1971). The Application of Psychological Testing to Entrepreneurial Potential. *California Management Review*, 13(3), 32-39.
- Parker, S.C. (2004). *The Economics of Self-Employment and Entrepreneurship*. Cambridge: Cambridge University Press.
- Parker, S. C., and Van Praag, M. C. (2006). Schooling, Capital Constraints, and Entrepreneurial Performance. *Journal of Business and Economic Statistics*, 24(4), 416-431.
- Pejvak, O., Marie-Louise, J., Kaveh, P., and Phillip, T. (2009). What Makes People Want to Become Self-Employed? Applying the Theory of Planned Behavior”. *Advances in Management* 2(11): 9–18.
- Penrose, E T. (1959/1980). *The Theory of the Growth of the Firm*. Oxford, UK: Basil Blackwell.
- Peter, P., and Edwin, S. (1994). The Effect of Education and Experience on Self-Employment Success. *Journal of Business Venturing* 9 (2): 141-156.
- Petridou, E., and Glaveli, N. (2008). Rural Women Entrepreneurship within Co-operatives: Training Support. *Gender in Management: An International Journal*, 23(4): 262 - 277.
- Peterman, N., and Kennedy, J. (2003). Enterprise Education: Influencing Students' Perceptions of Entrepreneurship. *Entrepreneurship: Theory & Practice*, 28(2): 129-144.
- Piacentini, M. (2013). Women Entrepreneurs in the OECD: Key Evidence and Policy Challenges. *OECD Social, Employment and Migration Working Papers, OECD Publishing, No. 147*.
- Piore, M. and Sabel, C. (1984). *The Second Industrial Divide: Possibilities for Prosperity*, Basic Books. New York.
- Podsakoff, P. M., MacKenzie, S. B., Lee, J. Y., and Podsakoff, N. P. (2003). Common Method Biases in Behavioral Research: A Critical Review of the Literature and Recommended Remedies. *Journal of Applied Psychology*, 88(5): 879–903.
- Premand, P., Stefanie, B., Rita. A., Rebekka, G., and Mahdi, B. (2012). *Entrepreneurship Training and Self-Employment among University Graduates: Evidence from a Randomized Trial in Tunisia*, Mimeo. World Bank.
- Radu, M., and Loué, C. (2008). Motivational Impact of Role Models as Moderated by “ideal” vs. “ought to self-guides” Identifications. *Journal of Enterprising Culture*, 16(4): 441.

- Raichaudhuri, A. (2005). *Issues in Entrepreneurship Education*. Decision 32(2): 73-84.
- Reynolds, P. (1991). Sociology and Entrepreneurship: Concepts and Contributions. *Entrepreneurship Theory and Practice* 16(2): 47–70.
- Rachel, C. and Uri. G. (2009). Gender Differences in Preferences. *Journal of Economic Literature*, 47:2, 1–27.
- Rees, H. and Shah, A. (1986). An Empirical Analysis of Self-employment in the U.K. *Journal of Applied Econometrics* 1(1), 95–108.
- Republic of South Africa (2004). South Africa's Broad-Based Black Economic Empowerment Act of 2003. *Government Gazette*, Act No. 53, 2003.
- Republic of Tanzania, *Small and Medium Enterprise Development Policy*, Ministry of Industry and Trade, Dar es Salaam, April 2003.
- Republic of Zambia (2011) *Sixth National Development plan 2011-2015: Sustained Economic Growth and Poverty Reduction*, Accessed from [http://siteresources.worldbank.org/INTZAMBIA/Resources/SNDP\\_Final\\_Draft\\_\\_20\\_01\\_2011.pdf](http://siteresources.worldbank.org/INTZAMBIA/Resources/SNDP_Final_Draft__20_01_2011.pdf).
- Reynolds, P.D. (1993). *The Role of Entrepreneurship in Economic Systems: Developed Market and Post-Socialist Economies*. Paper presented at the Second Freiberg Symposium on Economics, Freiberg, 9-11 September.
- Reynolds, P.D., Hay, M., and Camp, S.M. (1999). *Global Entrepreneurship Monitor: 1999 Executive Report*, Babson College, London Business School and the Kauffman Center for entrepreneurial leadership.
- Reynolds, P., Bygrave, W., Autio, E., Cox, L., and Hay, M. (2002). *Global Entrepreneurship Monitor: 2002 Executive Report*.
- Reynolds, P.D., Camp, S.M, Bygrave, W. D., Autio, E., and Hay, M. (2001), *Global Entrepreneurship Monitor 2001 Summary Report*.
- Reynolds, P., Bygrave, W., and Autio, E. (2004). *Global Entrepreneurship Monitor: 2004 Executive Report*. Kauffman Center for Entrepreneurial Leadership, Kansas City, MO.
- Reynolds, P., Bygrave, W. and Hay, M. (2003) *Global Entrepreneurship Monitor Report*. MO: E.M. Kauffmann Foundation, Kansas City
- Rezulli, L.A., Aldrich, H., and Moody, J. (2000). Family Matters: Gender, Networks and Entrepreneurial Outcomes. *Social Forces*, 79, 523-546.
- Rijkers, B., Söderbom, M., and Loening, J. L. (2010). A Rural-Urban Comparison of Manufacturing Enterprise Performance in Ethiopia. *World Development*, 38(9), 1278-1296
- Roberts, L. P. and Robinso, P. B. (2010). Home-Based Entrepreneurs, Commercial Entrepreneurs and White-Collar Workers: A Comparative Study of Attitudes toward Self-Esteem, Personal Control and Business Growth. *Journal of Small Business and Entrepreneurship*, 333-353.
- Robinson, P.B., Stimpson, D.V., Huefner, J.C., Hunt, H.K. (1991). An attitude Approach to the Prediction of Entrepreneurship. *Entrepreneurship Theory and Practice*, Vol. 15 No.4, pp.13-32.
- Rosendahl H. L., Sloof, R. and Van Praag, M. (2012). The Effect of Early Entrepreneurship Education: Evidence from a randomized field experiment. *IZA Discussion Paper* No. 6512, Germany.
- Rotter, J. B. (1966). Generalized Expectancies for Internal versus External Control of Reinforcement: *Psychological Monographs: General & Applied* 80(1), 1-28.

- Rotter J.B. (1990). Internal Versus External Control of Reinforcement: A Case History of a Variable, *American Psychologist*, April 1990, 490-493.
- Sánchez, J.C. (2011). University Training for Entrepreneurial Competencies: Its Impact on Intention of Venture Creation. *International Entrepreneurship and Management Journal*, (7), 239-254.
- Say, J. (1816). *A Treatise on Political Economy*. London: Sherwood, Neeley and Jones.
- Schjerning, B. and Le Maire, D. (2007). Earnings, Uncertainty, and the Self-Employment Choice. *Center for Economics and Business Research Discussion Paper 2007-04 04*.
- Schumpeter, Joseph A. (1934). *The Theory of Economic Development*. Cambridge, MA: Harvard University Press.
- Segal, G., Borgia, D., and Schoenfeld, J. (2005). The Motivation to Become an Entrepreneur. *International Journal of Entrepreneurial Behavior and Research*, 11 (1), 42-57.
- Seijts, G., and Latham, B. (2001). Can Goal Orientation Be Induced? Further Exploration of the State versus Trait Debate. In C. Sue-Chan, *Justice, Efficacy, Goal Orientation, Culture, and Creativity: New Findings in Motivation*. St. Foy, Quebec, Canada: Canadian Psychological Association.
- Sexton, D. L., and Bowman, N. (1985). The Entrepreneur: A Capable Executive and More. *Journal of Business Venturing*, 1, 129-140.
- Shane, S., and Stuart, T.E. (2002). Organizational Endowments and the Performance of University Start-ups. *Management Science*, 48: 154–170.
- Shane, S., and Venkataraman, S. (2000). The Promise of Entrepreneurship as a Field Of Research. *Academy of Management Review*, 25(1): 217-226.
- Shane, S., and Khurana, R. (2003). Bringing Individuals Back in: The Effects of Career Experience on New Firm Founding. *Industrial and Corporate Change*, 12(3): 519–543.
- Shane, S. (2003), “A General Theory of Entrepreneurship. The Individual-Opportunity Nexus. Cheltenham, UK: Edward Elgar.
- Shapiro, A. and Sokol, L. (1982). The Social Dimensions of Entrepreneurship. In *The Encyclopedia of entrepreneurship* (pp. 72-90). Englewood Cliffs, NJ: Prentice Hall.
- Shapiro, A. (1975). The Displaced, Uncomfortable Entrepreneur. *Psychology Today*, 9 (November), 83- 88, 133.
- Shaver, K.G and Scott, L.R. (1992). Person, Process, Choice: The Psychology of New Venture Creation. *Entrepreneurship Theory & Practice*, 16, 23-45.
- Shook, C., and Bratianu, C. (2010). Entrepreneurial Intent in a Transitional Economy: An Application of the Theory of Planned Behavior to Romanian Students. *International Entrepreneurship and Management Journal*, 6, 231-247.
- Simon, M., Houghton, S.M., and Aquino, K. (2000). Cognitive Biases, Risk Perception, and Venture Formation: How Individuals Decide to Start Companies, *Journal of Business Venturing*, 15, 2, 113-134.
- Slavtchev, V., Laspita, S., and Patzelt, H. (2012). Effects of Entrepreneurship Education at Universities. *Jena Economic Research Papers 2012 - 025*.
- Solesvik, M. (2007). *Attitudes towards Future Career Choice*. Stavanger Center for Innovation Research, University of Stavanger Norway.
- Soltow, James H. (1968). The Entrepreneur in Economic History. *American Economic Review*, May, 84-92.

- Sorensen, J. (2007). Closure vs. Exposure: Assessing Alternative Mechanisms in the Intergenerational Inheritance of Self-Employment. *Research in the Sociology of Organizations* 25: 83-124.
- Souitaris, V., Zerbini, S., and Al-Laham, A. (2007). Do Entrepreneurship Programmes Raise Entrepreneurial Intention of Science and Engineering Students? The Effect of Learning, Inspiration and Resources. *Journal of Business Venturing*, 22(4): 566-591.
- Sternberg, R., Bergmann, H. (2003). *Global Entrepreneurship Monitor (GEM) - Vergleich deutscher Regionen*.
- Stevenson, H. H. (1983). A Perspective on Entrepreneurship. *Harvard Business School Working Paper*, 9-384- 131
- Stevenson, H.H. and Gumpert, D. E. (1985). The Heart of Entrepreneurship. *Harvard Business Review*, March-April, 85-94.
- Stevenson, H. H. and Jarillo, J.J. (1990). A Paradigm of Entrepreneurship: Entrepreneurial Management. *Strategic Management Journal*, 11, pp. 17-27.
- Stewart, W.H. Jr. and Roth, P.L. (2001). Risk Propensity Differences between Entrepreneurs and Managers: A Meta-Analytic Review, *Journal of Applied psychology*, 86(1), 145.
- Storey, D.J. (1999). Six Steps to Heaven: Evaluating the Impact of Public Policies to Support Small Businesses in Developed Economies, in D.L. Sexton and H. Landstrom (eds.), *Handbook of Entrepreneurship*, Blackwells, Oxford, pp. 176-194.
- Taylor, M.P. (1996). Earning, Independence or Unemployment: Why Become Self-Employed? *Oxford Bulletin of Economics & Statistics*, 58, 253-66.
- Taylor, S. and Todd, P. (1995). Decomposition and Crossover Effects in the Theory of Planned Behavior: A Study of Consumer Adoption Intentions. *International Journal of Research in Marketing*, 12, 137-156.
- Times Higher Education World University Ranking 2014/15,  
<https://www.timeshighereducation.com/world-university-rankings/2015/world-ranking#!page/0/length/25>
- Timmons, J. (1978). Characteristics and Role Demands of Entrepreneurship. *American Journal of Small Business*, 3, 5-17.
- Tkachev, A. and Kolvereid, L. (1999). Self-Employment Intentions among Russian Students. *Entrepreneurship & Regional Development*, 11, 269-280.
- Thornton, P. H. (1999). The Sociology of Entrepreneurship. *Annual Review of Sociology* 25:19–46.
- Tung, L.C. (2011). *The Impact of Entrepreneurship Education on Entrepreneurial Intention of Engineering Students*. PhD Thesis, City University of Hong Kong.
- Tsordia, A., and Papadimitriou, D. (2015). The Role of Theory of Planned Behavior on Entrepreneurial Intention of Greek Business Students. *International Journal of Synergy and Research*, Vol 4, No1.
- UNCTAD (2012a). *Entrepreneurship Policy Framework and Implementation Guidance*. Accessed from [http://unctad.org/en/PublicationsLibrary/diaeed2012d1\\_en.pdf](http://unctad.org/en/PublicationsLibrary/diaeed2012d1_en.pdf)
- (2012b) *Entrepreneurship and Income Levels in Developing Countries*
- (2013) *Economic Development in Africa— Intra-African Trade: Unlocking Private Sector Dynamism*. United Nations, TD/B/60/4
- United States Small Business Administration Office of Advocacy, 2001, *Women in Business in 2001*.

- UNDP, Nepal: Boosting Entrepreneurship among Poor Rural Women, <http://www.undp.org/content/undp/en/home/ourwork/povertyreduction/successstories/nepal--boosting-entrepreneurship-among-poor-rural-women-.html>.
- UNIDO, Mozambique: Investing in a New Generation <http://www.unido.org/en/where-we-work/africa/selected-projects/mozambique-entrepreneurship-curriculum-programme.html>
- Upton, N., Sexton, D., and Moore, C. (1995). Have We Made a Difference? An examination of Career Activity of Entrepreneurship Majors Since 1981. *Frontiers of Entrepreneurship Research*.
- Van Gelderen, M.; Brand, M.; van Praag, M.; Bodewes, W.; Poutsma, E.; van Gils, A. (2006). Explaining Entrepreneurial Intentions by Means of the Theory of Planned Behavior. *Career Development International* Vol. 13, No. 6, pp. 538 - 559.
- Veciana, J.M., Aponte, M., and Urbano, D. (2005). University Students Attitudes towards Entrepreneurship: A Two Countries Comparison. *The international Entrepreneurship and Management Journal*, 1(2), 165- 182.
- Van Stel, A., Storey, D., Thurik, R. (2007). The Effect of Business Regulations on Nascent and Young Business Entrepreneurship, *Small Business Economics*, 28, 171 – 186
- Vegada, B.N, Karelia, B.N and Pillai, A. (2010). Reliability of Four-Response Type Multiple Choice Questions of Pharmacology Summative Tests of II M.B.B.S students. *International Journal of Mathematics and Statistics Invention (IJMSI)*, Volume 2 Issue 1, January. 2014 PP-06-10.
- Venkataraman, S. (1997). The Distinctive Domain of Entrepreneurship Research: An editor's Perspective. In J. Katz & R. Brockhaus (Eds.), *Advances in Entrepreneurship, Firm Emergence, and Growth*, vol. 3:119-138. Greenwich, CT: JAI Press.
- Vesalainen, J. and Pihkala, T. (1999). Motivation Structure and Entrepreneurial Intentions. In P. Reynolds et al. (Eds.), *Frontiers of entrepreneurship research* (pp. 73–87). Babson Park, MA: Babson College.
- Vesper, K., and Gartner, W.B. (1997). Measuring Progress in Entrepreneurship Education, *Journal of Business Venturing* 12: 403-421.
- Vesper, K.H. (1982). Research on Education for Entrepreneurship. In C. A. Kent, D.A. Sexton, & K. H. Vesper (Eds.), *Encyclopedia of Entrepreneurship*: 321-351. Englewood Cliffs, NJ: Prentice-Hall.
- Von Graevenitz, G., Harhoff, D., and Weber, R. (2010). The Effects of Entrepreneurship Education. *Journal of Economic Behavior & Organization*, 76(1): 90-112.
- Von Mises, L. (1949/1996). *Human Action: A Treatise on Economics*. Fourth Revised Edition ed. San Francisco: Fox & Wilkes.
- Wagner, J. (2003). The Impact of Personal Characteristics and the Regional Milieu of the Transition from Unemployment to Self-Employment: Empirical Evidence for Germany', *Jahrbucher fur Nationalokonomie und Statistik*, vol. 223(2), March, pp. 204-22
- Wagner, J. (2007). What a Difference a Y Makes – Female and Male Nascent Entrepreneurs in Germany, *Small Business Economics* 28, 1–21.
- Walker, E.A. and Webster, B.J. (2007). Gender, Age and Self-Employment: Somethings Change, Some Stay the Same. *Women in Management Review*, Vol. 22, No. 2, pp. 122- 135.
- Walras, L. (1954). *Elements of Pure Economics, or The Theory of Social Welfare*. London: Allen & Unwin for the American Economic Association and the Royal Economic Society.

- Wang, W., Lu, W., and Millington, J.K. (2011). Determinants of Entrepreneurial Intention among College Students in China and USA. *Journal of Global entrepreneurship research*, 1(1):35-44.
- Weber, M. (1947). *The Theory of Social and Economic Organization*. New York, USA: Oxford University Press.
- Wee, K. N. L. (2004). A Problem-Based Learning Approach in Entrepreneurship Education: Promoting Authentic Entrepreneurial Learning. *International Journal of Technology Management*, 28(7-8): 685-701.
- Welpe, I., Spörrle, M., Grichnik, D., Michl, T., and Audretsch, D.B. (2012). Emotions and Opportunities: The Interplay of Opportunity Evaluation, Fear, Joy, and Anger as Antecedent of Entrepreneurial Exploitation. *Entrepreneurship Theory and Practice*, Vol. 36 No. 1, pp. 69-96.
- Welter, F., and Lagemann, B. (2003). Gründerinnen in Deutschland – Potenziale und institutionelles Umfeld. Essen: Rheinisch-Westfälisches Institut für Wirtschaftsforschung
- Wooldridge, J. (2005). *Analysis of Cross Section and Panel Data*. The MIT Press, Cambridge, Massachusetts.
- Wilson, F., Kickul, J., and Marlino, D. (2007). Gender, Entrepreneurial Self-Efficacy, and Entrepreneurial Career Intentions: *Implications for Entrepreneurship Education*. *Entrepreneurship: Theory & Practice*, 31(3): 387-406.
- Woolf, H. B. (1980). *Webster's New Collegiate Dictionary*. Springfield, MA: G. & C. Merriam Company.
- World Bank. 2004. *World Development Report 2005: A Better Business Climate for Everyone*. World Bank, Washington.
- World Bank, Doing Business Report. (2014). *Starting a Business*. Accessed from <http://www.doingbusiness.org/data/exploretopics/starting-a-business>.
- (2016). *Measuring Regulatory Quality and Efficiency* accessed on December 10/2014 from <http://www.doingbusiness.org/~media/GIAWB/Doing%20Business/Documents/Annual-Reports/English/DB16-Full-Report.pdf>
- Yasuhiro, S., Tabuchi, T., and Yamamoto, K. (2012). *Market Size and Entrepreneurship*. Oxford University Press.
- Zacharakis, A.L., Bygrave, W.D., Shepherd, D.A., (2000). *Global Entrepreneurship Monitor: National Entrepreneurship Assessment: United States of America*. Kauffman Center for Entrepreneurial Leadership, Kansas City.
- Zhang, Y., Duysters, G., and Cloudt, M. (2013). The Role of Entrepreneurship Education as a Predictor of University Students' Entrepreneurial Intention. *International Entrepreneurship and Management Journal*.
- Zhao, H., Seibert, C., and Hills, C. (2005). The Mediating Role of Self-Efficacy in the Development of Entrepreneurial Intentions. *Journal of Applied Psychology* (90): 1265-1272.
- Zietsma, C. (1999). Opportunity knocks-or Does it Hide? An Examination of the Role of Opportunity Recognition in Entrepreneurship." *Frontiers of Entrepreneurship*, 242–256.

## Appendices

Appendix 1: Probit estimation results by country

Variable	South Africa	Morocco	Algeria	Tunisia	Uganda
Male	.038 (0.722)	.03(0.125)	.10(0.215)	.012(0.35)	.05(0.439)
Age	-.01(0.034)	-.02(0.041)	-.01(0.02)	-.012(0.03)	-.01(0.000)
Not Working	-.59( 0.000)	-.17(0.000)	-.2(0.000)	-.05(0.031)	-.95(0.000)
Retired & students	-.74(0.000)	-.01(0.000)	-.25(0.000)	-.03(0.000)	-.91(0.000)
No Education	-.14(0.487)	.95(0.007)	.07(0.003)	.06(0.005)	.09(0.025)
Uni Education	.38(0.124)	-.96(0.083)	-.09(0.210)	-.15(0.09)	.35(0.302)
Low Income	.08(0.589)	.02(0.023)	.59(0.002)	.03(0.081)	.16(0.038)
Upper Income	.06(0.67)	.025(0.138)	.41(0.13)	.52(0.251)	.13(0.537)
knowneny	.36(0.001)	-.26(0.000)	.58(0.000)	.05(0.000)	.11(0.000)
suskily	.15(0.000)	-.04(0.000)	.47(0.003)	.26(0.000)	.35(0.002)
frfaily	-.41(0.002)	-.53(0.316)	.32(0.146)	-.08(0.041)	-.05(0.452)

### Appendix2: Questionnaire Survey on Entrepreneurship Education for Engineering Students

#### Questionnaire Survey On Entrepreneurial Intentions of University Students

Dear student

Thank you for your consent to take part in this important survey assessing the impact of entrepreneurship education on the entrepreneurial intentions of university students.

The data will only be accessed by the researcher and all personal data will be kept strictly confidential and will be coded to render anonymity. In order to measure the impact of entrepreneurial education, it will be necessary to survey you again during the program. Therefore, I will be grateful if you write your ID number herein below.

Student ID:

Once again, many thanks for taking your time to fill out the questionnaire!

Best regards,  
Habtamu Legas

PhD Candidate

[habtamu.legas@unibg.it](mailto:habtamu.legas@unibg.it) or [habtamuadane21@yahoo.com](mailto:habtamuadane21@yahoo.com)



Tutor,  
 Lilli Casano(PhD)  
[lilli.casano@adapt.it](mailto:lilli.casano@adapt.it)

**Section 1: Personal Information**

1. Age–
2. Gender: Female  Male
3. Parents’ Occupation
  - 3.1.Father self-employed No  Yes
  - 3.2.Mother self-employed No  Yes
4. Socioeconomic level
  - 4.1. Father’s level of studies No/Primary  Secondary  University
  - 4.2. Mother’s level of studies No/ Primary  Secondary  University
  - 4.3. Income level Low  Medium  High
5. Have you ever worked for a start-up (young, small company)? Yes  No
6. Have you ever been self-employed (independent worker or firm owner)? Yes  No

**Section 2: Education Experience**

Have you ever taken any entrepreneurship course(s)? Yes  No

**Section 3: Personal Attitude**

Indicate your level of agreement with the following sentences from 1 (total disagreement) to 7 (total agreement).

	1	2	3	4	5	6	7
A. Being an entrepreneur implies more advantages than disadvantages to me	<input type="checkbox"/>	<input type="checkbox"/>	<input type="checkbox"/>	<input type="checkbox"/>	<input type="checkbox"/>	<input type="checkbox"/>	<input type="checkbox"/>
B. A career as entrepreneur is attractive for me	<input type="checkbox"/>	<input type="checkbox"/>	<input type="checkbox"/>	<input type="checkbox"/>	<input type="checkbox"/>	<input type="checkbox"/>	<input type="checkbox"/>
C. If I had the opportunity and resources, I’d like to start a firm	<input type="checkbox"/>	<input type="checkbox"/>	<input type="checkbox"/>	<input type="checkbox"/>	<input type="checkbox"/>	<input type="checkbox"/>	<input type="checkbox"/>
D. Being an entrepreneur would give me great satisfaction	<input type="checkbox"/>	<input type="checkbox"/>	<input type="checkbox"/>	<input type="checkbox"/>	<input type="checkbox"/>	<input type="checkbox"/>	<input type="checkbox"/>
E. Among various options, I would rather be an entrepreneur	<input type="checkbox"/>	<input type="checkbox"/>	<input type="checkbox"/>	<input type="checkbox"/>	<input type="checkbox"/>	<input type="checkbox"/>	<input type="checkbox"/>

**Section 4: Subjective Norm**

If you decided to create a firm, would people in your close environment approve of that decision?  
 Indicate from 1 (total disapproval) to 7 (total approval).

	1	2	3	4	5	6	7
A- Your close family	<input type="checkbox"/>	<input type="checkbox"/>	<input type="checkbox"/>	<input type="checkbox"/>	<input type="checkbox"/>	<input type="checkbox"/>	<input type="checkbox"/>
B- Your close friends	<input type="checkbox"/>	<input type="checkbox"/>	<input type="checkbox"/>	<input type="checkbox"/>	<input type="checkbox"/>	<input type="checkbox"/>	<input type="checkbox"/>
C- Your friends from University	<input type="checkbox"/>	<input type="checkbox"/>	<input type="checkbox"/>	<input type="checkbox"/>	<input type="checkbox"/>	<input type="checkbox"/>	<input type="checkbox"/>

**Section 5: Perceived Behavioral Control**

To what extent do you agree with the following statements regarding your entrepreneurial capacity?  
 Value them from 1 (total disagreement) to 7 (total agreement).

	1	2	3	4	5	6	7
A- Starting a firm and keeping it working would be easy for me	<input type="checkbox"/>	<input type="checkbox"/>	<input type="checkbox"/>	<input type="checkbox"/>	<input type="checkbox"/>	<input type="checkbox"/>	<input type="checkbox"/>
B- I am prepared to start a viable firm	<input type="checkbox"/>	<input type="checkbox"/>	<input type="checkbox"/>	<input type="checkbox"/>	<input type="checkbox"/>	<input type="checkbox"/>	<input type="checkbox"/>
C- I can control the creation process of a new firm	<input type="checkbox"/>	<input type="checkbox"/>	<input type="checkbox"/>	<input type="checkbox"/>	<input type="checkbox"/>	<input type="checkbox"/>	<input type="checkbox"/>
D- I know all the necessary practical details to start a firm	<input type="checkbox"/>	<input type="checkbox"/>	<input type="checkbox"/>	<input type="checkbox"/>	<input type="checkbox"/>	<input type="checkbox"/>	<input type="checkbox"/>
E- I know how to develop an entrepreneurial project	<input type="checkbox"/>	<input type="checkbox"/>	<input type="checkbox"/>	<input type="checkbox"/>	<input type="checkbox"/>	<input type="checkbox"/>	<input type="checkbox"/>
F- If I tried to start a firm, I would have a high probability of succeeding	<input type="checkbox"/>	<input type="checkbox"/>	<input type="checkbox"/>	<input type="checkbox"/>	<input type="checkbox"/>	<input type="checkbox"/>	<input type="checkbox"/>

## Section 6: Entrepreneurial Intention

Indicate your level of agreement with the following statements from 1 (total disagreement) to 7 (total agreement)

	1	2	3	4	5	6	7
A- I am ready to do anything to be an entrepreneur	<input type="checkbox"/>	<input type="checkbox"/>	<input type="checkbox"/>	<input type="checkbox"/>	<input type="checkbox"/>	<input type="checkbox"/>	<input type="checkbox"/>
B- My professional goal is becoming an entrepreneur	<input type="checkbox"/>	<input type="checkbox"/>	<input type="checkbox"/>	<input type="checkbox"/>	<input type="checkbox"/>	<input type="checkbox"/>	<input type="checkbox"/>
C- I will make every effort to start and run my own firm	<input type="checkbox"/>	<input type="checkbox"/>	<input type="checkbox"/>	<input type="checkbox"/>	<input type="checkbox"/>	<input type="checkbox"/>	<input type="checkbox"/>
D- I am determined to create a firm in the future	<input type="checkbox"/>	<input type="checkbox"/>	<input type="checkbox"/>	<input type="checkbox"/>	<input type="checkbox"/>	<input type="checkbox"/>	<input type="checkbox"/>
E- I have very seriously thought of starting a firm	<input type="checkbox"/>	<input type="checkbox"/>	<input type="checkbox"/>	<input type="checkbox"/>	<input type="checkbox"/>	<input type="checkbox"/>	<input type="checkbox"/>
F- I have the firm intention to start a firm some day	<input type="checkbox"/>	<input type="checkbox"/>	<input type="checkbox"/>	<input type="checkbox"/>	<input type="checkbox"/>	<input type="checkbox"/>	<input type="checkbox"/>

Please leave us a comment below if you have any other suggestions:

-----

-----

-----

-----

THANK YOU!

### Appendix 3: Inter-item Correlations (Obs=269)

	A1	A2	A3	A4	A5	S1	S2	S3	P1	P2	P3
A1	1.0000										
A2	0.8996	1.0000									
A3	0.8825	0.9064	1.0000								
A4	0.8431	0.8607	0.9067	1.0000							
A5	0.8416	0.8661	0.8902	0.8941	1.0000						
S1	0.7992	0.7784	0.7713	0.7383	0.7694	1.0000					
S2	0.7568	0.7429	0.7415	0.7189	0.7367	0.8763	1.0000				
S3	0.7512	0.7258	0.7110	0.6965	0.7032	0.8692	0.8777	1.0000			
P1	0.7214	0.7270	0.6890	0.6553	0.6920	0.7485	0.7066	0.7179	1.0000		
P2	0.7748	0.7634	0.7260	0.6990	0.7021	0.7766	0.7239	0.7265	0.7951	1.0000	
P3	0.7909	0.7703	0.7312	0.7203	0.7154	0.7801	0.7351	0.7277	0.7750	0.8775	1.0000
P4	0.7959	0.7710	0.7361	0.7012	0.7082	0.7837	0.7495	0.7422	0.7586	0.8676	0.8953
P5	0.7519	0.7351	0.7052	0.6593	0.6855	0.7649	0.7172	0.7153	0.7332	0.8387	0.8525
P6	0.7525	0.7302	0.6829	0.6528	0.6622	0.7706	0.7296	0.7270	0.7330	0.8424	0.8464
I1	0.7734	0.7561	0.7108	0.6909	0.6872	0.7571	0.7261	0.7178	0.7485	0.8302	0.8639
I2	0.8070	0.7831	0.7502	0.7178	0.7330	0.7967	0.7796	0.7578	0.7718	0.8393	0.8610
I3	0.7794	0.7594	0.7300	0.6747	0.7042	0.7755	0.7383	0.7344	0.7537	0.7969	0.8257
I4	0.8118	0.7923	0.7732	0.7336	0.7527	0.7983	0.7668	0.7337	0.7772	0.8377	0.8570
I5	0.7789	0.7858	0.7521	0.7160	0.7468	0.8004	0.7572	0.7505	0.7713	0.8152	0.8248
I6	0.8046	0.7882	0.7598	0.7283	0.7468	0.8097	0.7729	0.7723	0.7756	0.8480	0.8491
	P4	P5	P6	I1	I2	I3	I4	I5	I6		
P4	1.0000										
P5	0.8828	1.0000									
P6	0.8650	0.8619	1.0000								
I1	0.8559	0.8371	0.8639	1.0000							
I2	0.8650	0.8390	0.8604	0.8557	1.0000						
I3	0.8385	0.8012	0.8282	0.8143	0.8661	1.0000					
I4	0.8441	0.8211	0.8298	0.8443	0.8774	0.8973	1.0000				
I5	0.8206	0.8181	0.8359	0.8046	0.8381	0.8454	0.9052	1.0000			
I6	0.8499	0.8393	0.8342	0.8337	0.8718	0.8710	0.8801	0.8858	1.0000		

