



MIT Open Access Articles

An Enterprise Control Assessment Method for Variable Energy Resource-Induced Power System Imbalances--Part I: Methodology

The MIT Faculty has made this article openly available. **Please share** how this access benefits you. Your story matters.

Citation	Muzhikyan, Aramazd, Amro M. Farid, and Kamal Youcef-Toumi. "An Enterprise Control Assessment Method for Variable Energy Resource-Induced Power System Imbalances--Part I: Methodology." IEEE Trans. Ind. Electron. 62, no. 4 (April 2015): 2448–2458.
As Published	http://dx.doi.org/10.1109/tie.2015.2395391
Publisher	Institute of Electrical and Electronics Engineers (IEEE)
Version	Author's final manuscript
Citable link	http://hdl.handle.net/1721.1/97748
Terms of Use	Creative Commons Attribution-Noncommercial-Share Alike
Detailed Terms	http://creativecommons.org/licenses/by-nc-sa/4.0/

An Enterprise Control Assessment Method for Variable Energy Resource Induced Power System Imbalances. Part 1: Methodology

Aramazd Muzhikyan, *Student Member, IEEE*, Amro M. Farid, *Member, IEEE*,
and Kamal Youcef-Toumi, *Member, IEEE*

Abstract—In recent years, an extensive academic and industrial literature has developed to determine how much such variable energy resources (VER) may be integrated and how to best mitigate their impacts. While certainly insightful within the context of their application, many integration studies have methodological limitations in that they are case specific, address a single control function of power grid balancing operations, and are often not validated by simulation. This paper presents a holistic method for the assessment of power grid imbalances induced by variable energy resources based upon the concept of enterprise control. It consists within a single package a three layer enterprise control simulator which includes most of the balancing operation functionality found in traditional power systems. The control layers include a resource scheduling layer composed of a security-constrained unit commitment, a balancing layer composed of a security-constrained economic dispatch, and a regulation layer. The proposed method is validated by a set of numerical simulations. The sequel to this paper submitted to the same issue provides a set of extensive results that demonstrate how power grid balancing operations systematically address variable energy resource integration.

Index Terms—Power system imbalances, enterprise control, variable energy resources.

I. INTRODUCTION

IN recent years, the trend towards renewable energy integration has developed to address energy security and global climate change drivers. And yet, as energy sources, they possess a variable and uncertain nature that significantly complicates power grid balancing operations. To address these challenges, an extensive academic and industrial literature has developed addressing both technical and economic aspects of variable energy resource (VER) integration [1]–[3]. The main conclusion of such integration studies is that renewable energy integration requires the procurement of additional generation

reserves [4]–[9]; although they often disagree on their exact quantity.

While certainly insightful within the context of their application, many integration studies have significant methodological limitations [10], [11]. First, most of these results are based on specific case studies [12], [13] and do not allow generalization [14]. Moreover, most of the studies are limited to a single control function of balancing operations; often either unit commitment or economic dispatch. For example, the authors in [15] consider an economic dispatch at 10 minute resolution but neglects regulation. This restricts the scope of the results to the time scale of the chosen function, and neglects the fact that VERs introduce variability at all timescales [16], [17]. Furthermore, most of the studies are limited to statistical calculations, which are yet to be validated by simulations [4], [14]. Of these, some are limited to considering either only variability of the net load [18]–[20] or only its forecast error [21]–[24]. Those wind power integration studies that do use simulation usually do so for a particular study area [25]. References [14], [19] implement only unit commitment models, according to the assumption that wind integration has the biggest impact on unit commitment. Finally, many of the calculations are based upon the experience of system operators which may not necessarily remain valid as the power system continues to evolve. In summary, a review of the existing literature on imbalance assessment methodologies shows a lack of holistic methods in which the variability and penetration characteristics of the renewable energy is directly tied to the power system imbalances [10], [11].

This paper seeks to develop such a generalized approach based upon previous work in the area [26], [27]. It draws as inspiration the concept of integrated enterprise control in which both physical as well as enterprise processes are modeled to gain an understanding of the holistic system behavior [28]–[30]. In such a way, the variability of renewable energy resources can be viewed as an input disturbance which the (enterprise) power system systematically manages to deliver attenuated power system imbalances. Consequently, the power from renewable energy sources is modeled in terms of its key characteristics: penetration level, forecast error, and variability. Furthermore, the enterprise power system modeling [26], [27] includes three control layers namely: resource scheduling, balancing actions as well as regulation service layer on top of the physical power grid, which represents the buses, transmission lines, loads and generators. While it is not possible

Manuscript received February 25, 2014; revised June 14, 2014, October 10, 2014 and November 28, 2014; accepted December 19, 2014.

Copyright © 2015 IEEE. Personal use of this material is permitted. However, permission to use this material for any other purposes must be obtained from the IEEE by sending a request to pubs-permissions@ieee.org

A. Muzhikyan is with the Department of Engineering Systems and Management, Masdar Institute of Science and Technology, PO Box 54224, Abu Dhabi, UAE. amuzhikyan@masdar.ac.ae

A. M. Farid is with Faculty of Engineering Systems and Management, Masdar Institute of Science and Technology, PO Box 54224, Abu Dhabi, UAE. afarid@masdar.ac.ae

K. Youcef-Toumi is with Faculty of Mechanical Engineering, Massachusetts Institute of Technology, 77 Massachusetts Avenue Cambridge, MA 02139, USA. youcef@mit.edu

within the scope of this paper to model all enterprise power system processes, the ones most relevant to power system imbalances are captured: unit commitment, regulation service, real-time market, and operator manual actions. The notion of multi-layered power system control has been introduced in the literature before [31], [32]. Reference [33] proposes a modeling framework by decomposing the power system control equations into multistage operations. Similarly, [34] studies multiple timescales of the power system operations from an energy storage integration perspective. In contrast, one of the major contributions of this paper is that integration of power system control layers also guarantees case-independence of the assessment results. To this end, some modifications of the control procedures are implemented as discussed in Section III. The application of the proposed method to the assessment of the reserve requirements is found in the sequel to this paper submitted to the same journal [35].

The remainder paper is organized as follows. Section II provides background descriptions of power system balancing operations. Section III then gives the detailed description of the enterprise control assessment methodology. Section IV is devoted to the validation of the proposed methodology by a set of simulations. Finally, Section V presents the conclusions.

II. BACKGROUND

For normal power system balancing operations, the system behavior is traditionally classified as a hierarchy of primary, secondary, and tertiary controls [36]. The primary control addresses transient stability phenomena in the range of $0.1 - 10\text{sec}$ [37]. The secondary control, commonly referred to as automatic generation control (AGC), interacts with the dispatched generators in the control area to maintain the power balance and the system frequency, and acts in a timescale of $20\text{s} - 2\text{min}$. Tertiary control is normally implemented as a security-constrained economic dispatch (SCED) and provides power setpoints to the generators ($5 - 15\text{min}$). Balancing operations also include day-ahead scheduling that defines the optimal set of generation units for the following day and is commonly implemented as a security-constrained unit commitment (SCUC) problem. Both SCUC and SCED represent the normal operating decisions executed by the day-ahead and real-time markets respectively. Although these markets only work as part of normal operation, they do set aside operating reserves which may be utilized in either normal or contingency (i.e. emergency) operation. This section provides background information to each of these: SCUC, SCED, Generation Model & AGC. Additionally, some fundamental definitions are provided to facilitate the development of the methodology in the next section.

A. Security-Constrained Unit Commitment (SCUC)

The goal of the SCUC problem is to choose the right set of generation units, that are able to meet the real-time demand with minimum cost. In the original formulation, the SCUC problem is formulated as a nonlinear optimization problem with integrated power flow equations and system

security requirements [38]. The cost of generation units is approximated as a quadratic function in the following form:

$$C(P) = C^F + C^L P + C^Q P^2 \quad (1)$$

where C^F , C^L and C^Q are fixed, linear and quadratic cost coefficients respectively. However, the constraints are often linearized to avoid convergence issues:

$$\min \sum_{i=1}^{24} \sum_{t=1}^{N_G} \left(w_{it} C_i^F + C_i^L P_{it} + C_i^Q P_{it}^2 + w_{it}^u C_i^U + w_{it}^d C_i^D \right) \quad (2)$$

$$\text{s.t.} \quad \sum_{i=1}^{N_G} P_{it} = \hat{D}_t \quad (3)$$

$$-R_i^{\max} T_h \leq P_{it} - P_{i,t-1} \leq R_i^{\max} T_h \quad (4)$$

$$w_{it} P_i^{\min} \leq P_{it} \leq w_{it} P_i^{\max} \quad (5)$$

$$w_{it} = w_{i,t-1} + w_{it}^u - w_{it}^d \quad (6)$$

$$\sum_{i=1}^{N_G} w_{it} P_i^{\max} - \sum_{i=1}^{N_G} P_{it} \geq P_{res} \quad (7)$$

i and t are generator and time indices respectively. The following notations are used:

C_i^U, C_i^D	startup and shutdown costs of generator i
P_{it}	power output of generator i at time t
\hat{D}_t	total demand forecast at time t
P_i^{\max}, P_i^{\min}	max/min power limits of generator i
R_i^{\max}	maximum ramping rate of generator i
T_h	scheduling time step (normally, 1 hour)
N_G	number of generators
w_{it}	ON/OFF state of the generator i
w_{it}^u, w_{it}^d	startup/shutdown indicators of generator i
P_{res}	system reserve requirements

Constraint (3) corresponds to the power balance equation. Constraints (4) and (5) are the physical limitations on generators' ramping rates and power outputs respectively. The last constraint ensures procurement of the load following reserves.

B. Security-Constrained Economic Dispatch (SCED)

The real-time market moves available generator outputs to new setpoints (re-dispatch) in the most cost-efficient way. In its original formulation, generation re-dispatch is implemented as a non-linear optimization model, called AC optimal power flow (ACOPF) [39]. Due to problems with convergence and computational complexity [38], most of the U.S. independent system operators (ISO) moved from ACOPF to linear optimization models. The most commonly used model is called Security-Constrained Economic Dispatch (SCED) and is formulated as an incremental linear optimization problem [40]:

$$\min \sum_{i=1}^{N_G} (C_i^L \Delta P_{it} + 2C_i^Q P_{it} \Delta P_{it}) \quad (8)$$

$$\text{s.t.} \quad \Delta P_{jt} = \sum_{i=1}^{N_G} B_{ji} \Delta P_{it} \quad (9)$$

$$\sum_{j=1}^{N_B} (1 - \gamma_{jt}) (\Delta P_{jt} - \Delta \hat{D}_{jt}) = 0 \quad (10)$$

$$\sum_{j=1}^{N_B} a_{ljt} (\Delta P_{jt} - \Delta \hat{D}_{jt}) \leq F_l^{max} - F_{lt} \quad (11)$$

$$-R_i T_m \leq \Delta P_{it} \leq R_i T_m \quad (12)$$

$$P_{it} - P_i^{min} \leq \Delta P_{it} \leq P_i^{max} - P_{it} \quad (13)$$

where i , j , l and t are generator, bus, line and time indices respectively. The following notations are used:

ΔP_{it}	power increment of generation i
$\Delta \hat{D}_{jt}, \Delta P_{jt}$	demand forecast and generation increments on bus j
B_{ji}	correspondence matrix of generator i to bus j
F_{lt}, F_l^{max}	power flow level and flow limit of line l
γ_{it}	incremental transmission loss factor of bus i
a_{lit}	bus i generation shift distribution factor to line l
N_B	number of buses
T_m	real-time market time step (normally, 5 minutes)

Use of incremental values for generation and load allows incorporation of sensitivity factors and problem linearization. Sensitivity factors establish linear connections between changes of power injections on the buses and state-related parameters of the system [41]. Two sensitivity factors are used in the SCED. The incremental transmission loss factor (ITLF) for bus i shows how much the total system losses change, when power injection on bus i increases by a unit [42]. The incorporation of ITLF into the model results in a linearization of the power balance constraint (10). The generation shift distribution factor (GDSF) shows how much the active power flow through line l changes, when injection on bus i increases by a unit [42], [43]. The incorporation of GDSF into the model results in a linearization of the line flow limit constraint (11). Constraints (12) and (13) are the physical limits of the generator ramping rates and outputs. The SCED objective function is the first derivative of the cost function (1):

$$\Delta C(P) = C^L \Delta P + 2C^Q P \Delta P \quad (14)$$

Some input parameters of the SCED problem, such as P_{it} , F_{lt} , γ_{it} , a_{lit} , depend on the current state of the system. These parameters are calculated before each SCED iteration based on a full AC power flow analysis of the system. The literature often refers to the usage of such *a priori* information as “hot start models” [40].

C. Generator Model and Automatic Generation Control

A generic model of generator dynamics with integrated prime mover and governor is presented in Fig. 1 [44], where the following notations are used:

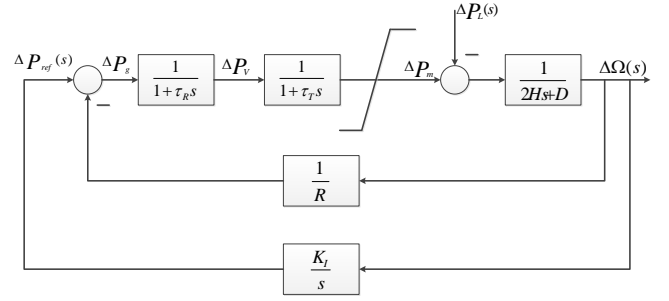

Fig. 1. The generic form of the generator primary control

$\Delta \Omega(s)$	system frequency deviation
$\Delta P_L(s)$	nonfrequency-sensitive load change
$\Delta P_m(s)$	mechanical power change
$\Delta P_v(s)$	steam valve position
$\Delta P_g(s)$	speed governor output
$\Delta P_{ref}(s)$	reference power
H	generator inertia
D	load sensitivity to the system frequency
R	governor speed regulation curve slope
τ_R, τ_T	governor and turbine time constants

AGC is implemented as a feedback loop as follows [44]:

$$\Delta P_{ref}(s) = \frac{K_I}{s} \Delta \Omega(s) \quad (15)$$

where K_I is the controller gain. The residual imbalance is called area control error (ACE) and for each control area i is defined as [36]:

$$ACE_i = B_i \Delta f_i + \sum_{j=1}^n \Delta P_{ij} \quad (16)$$

where $\Delta f_i = \Delta \Omega_i / 2\pi$, B_i is the frequency bias, and ΔP_{ij} is the change in the power with respect to its scheduled value in the tie-line between areas i and j . According to the control performance standards (CPS) defined by the North American Electric Reliability Corporation (NERC), each balancing authority shall operate such that its average ACE for at least 90% of clock-ten-minute periods (6 non-overlapping periods per hour) during a calendar month is within a specific limit called the L_{10} [45]:

$$AVG_{10-minute}(ACE_i) \leq L_{10} \quad (17)$$

D. Fundamental Definitions

In order to facilitate the usage of this work across different power systems, a number of non-dimensional quantities are introduced.

Definition 1. Penetration Level (π): The installed VER capacity P_V^{max} normalized by the system peak load P_L^{peak} [46]:

$$\pi = P_V^{max} / P_L^{peak} \quad (18)$$

Definition 2. *VER Capacity Factor (γ):* The average VER power output $\overline{P_V(t)}$ (e.g., over 1 year period) per installed capacity:

$$\gamma = \frac{\overline{P_V(t)}}{P_V^{max}} \quad (19)$$

Next, it is important to introduce the concept of variability as it is applied to the VERs, the load, and/or the net load. The variability of each of these plays a significant role in balancing operations. Nevertheless, no mathematical definition of variability has been found in the literature. Intuitively speaking, variability is associated with the change rates of a given output. In this paper, it is defined as:

Definition 3. *Variability (A):* Given the choice of the output $P(t)$ (e.g. the VER generation, the load, the net load), the variability is the root-mean-square of that output's rate normalized by the root-mean-square of that output [47]:

$$A = \frac{\text{rms}(dP(t)/dt)}{\text{rms}(P(t))} \quad (20)$$

Since the power spectra of the VER and load have distinctive shapes [16], [17], the way to change the variability of the profile without distorting its spectral shape is temporal scaling [47]. Assume that a default profile $P_0(t)$ has a variability A_0 and $P(t)$ is related to it in the following way:

$$P(t) = P_0(\alpha t) \quad (21)$$

According to (20), the variability of $P(t)$ is:

$$A = \frac{\text{rms}(dP_0(\alpha t)/dt)}{\text{rms}(P_0(\alpha t))} = \alpha \cdot \frac{\text{rms}(dP_0(\alpha t)/d(\alpha t))}{\text{rms}(P_0(\alpha t))} = \alpha A_0 \quad (22)$$

Thus, α can be viewed as a scaling factor between the given profile and the default profile variabilities:

$$\alpha = \frac{A}{A_0} \quad (23)$$

The definitions for the forecast and forecast error are introduced next. Fundamentally speaking, while the net load is a continuously varying function in time, the forecast has a specific value resolved with each day ahead market time block (e.g. 1 hour). Therefore, the two are inherently different types of quantities. To address this issue, the concept of a ‘‘Best Forecast’’ is introduced as:

Definition 4. *The Best Forecast [47]:* Given the output $P(t)$ (e.g. the VER generation, the load, the net load), the best forecast \bar{P}_k is equivalent to the average value of that output during the k^{th} market time block of duration T :

$$\bar{P}_k = \frac{1}{T} \int_{kT}^{(k+1)T} P(t) dt \quad (24)$$

Similarly, the forecast error defines the deviation between the actual and best forecasts, which in turn may have various measures such as mean absolute error (MAE) and mean square error (MSE) [48]. Here, the VER forecast error is normalization by the installed capacity.

TABLE I
THE CLASSIFICATION OF RESERVES USED IN THIS PAPER

Name	Definition	Activation mechanism
Load following	Capacity available during normal operations for assistance in active power balance to correct the future anticipated imbalance (upward and downward).	Real-time market (SCED)
Ramping	Capacity available for assistance in active power balance during infrequent events that are more severe than balancing needed during normal conditions and is used to correct non-instantaneous imbalances (upward and downward).	Real-time market (SCED)
Regulation	Capacity available during normal operations for assistance in active power balance to correct the current imbalance (upward and downward).	Regulation service (AGC)

Definition 5. *VER Forecast Error (ε) [47]:* The standard deviation of the difference between the best (\bar{P}_k) and actual VER forecasts (\hat{P}_k) normalized by the installed capacity:

$$\varepsilon = \frac{\sqrt{\frac{1}{n} \sum_{k=0}^n (\bar{P}_k - \hat{P}_k)^2}}{P_V^{max}} \quad (25)$$

Finally, the definitions of the reserve types used in this paper are presented in Table I. This paper uses the classification of reserves found in [4], [5].

III. METHODOLOGY AND SIMULATION SETUP

Given the background information provided in the previous section, the paper turns to describe the methodology of the power grid enterprise control assessment. The enterprise model used in this study is comprised of three interconnected control layers on top of the physical power grid: resource scheduling, balancing actions and the regulation, as presented in Fig. 2. Together, they reflect the behavior of a power system under normal operation. The detailed descriptions of each layer are presented in the following subsections.

A. Resources Scheduling

Power system balancing starts with the day-ahead scheduling of the resources. According to Fig. 2, this stage accomplishes two main goals, namely: unit commitment and reserve scheduling. While the unit commitment problem formulation presented in (2)-(7) is often used for these purposes, its as-stated application in integration studies is problematic. It implicitly makes conjectures which can be proven false, thus potentially invalidating the results of the entire integration study. This subsection identifies these conjectures, proves them false by counterexample and then proceeds to offer a modified SCUC formulation which avoids the previous limitations.

Conjecture 1. Constraint (5) in the traditional SCUC formulation guarantees that the minimum total output of the scheduled generation is lower than the real-time demand $D(t)$ and the losses $L(t)$. $\sum_{i=1}^{N_G} w_{it} P_i^{min} \leq D(t) + L(t)$.

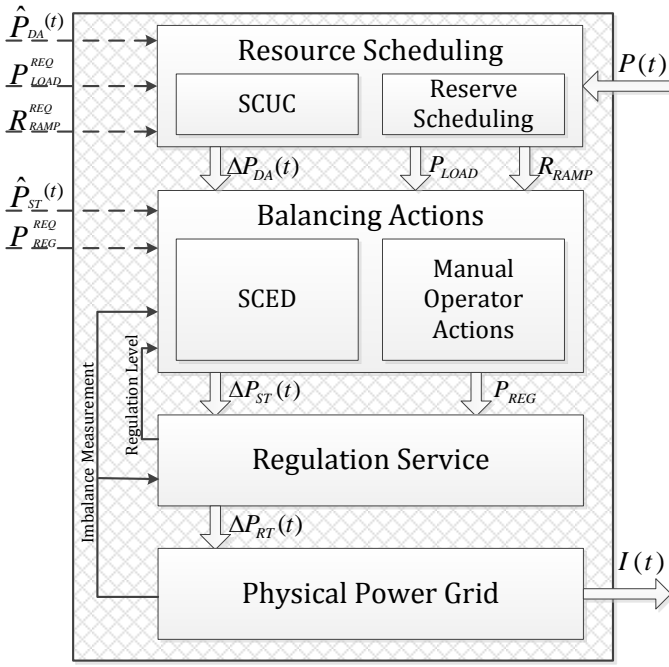

Fig. 2. Conceptual model of a power grid enterprise control simulator

Counter-Proof: By definition, the range of the total generation that the system can provide is defined by the set of the committed generation units and their maximum and minimum outputs:

$$\left[\sum_{i=1}^{N_G} w_{it} P_i^{min}, \sum_{i=1}^{N_G} w_{it} P_i^{max} \right] \quad (26)$$

Rearranging (3), (5) and (7), gives:

$$\sum_{i=1}^{N_G} w_{it} P_i^{max} \geq \hat{D}_t + P_{res} \quad (27)$$

$$\sum_{i=1}^{N_G} w_{it} P_i^{min} \leq \hat{D}_t \quad (28)$$

Consider the power differential $\Delta P(t)$ defined as:

$$\Delta P(t) = D(t) + L(t) - \hat{D}_t \quad (29)$$

In the case that the minimum total output of the scheduled generation is equal to the day-ahead demand forecast, $\sum_{i=1}^{N_G} w_{it} P_i^{min} = \hat{D}_t$, and the real-time demand is less than the forecasted demand, $\Delta P(t) \leq 0$, the conjecture is false. ■

In such situations, the independent system operator normally issues a minimum generation alert, suspends market activity and proceeds to manual operation of the grid [49]. Such a situation has occurred within PJM-ISO in 2005 when nuclear plants were not able to ramp down to an unpredicted drop in real-time demand in the early morning hours [50].

Remark. Rewriting the power differential $\Delta P(t)$ in terms of the average demand over the day-ahead market scheduling time block gives:

$$\Delta P(t) = D(t) + L(t) - \hat{D}_t = [D(t) - \bar{D}(t)] + [\bar{D}(t) - \hat{D}_t] + L(t) \quad (30)$$

Thus the $\Delta P(t)$ depends on three factors: the profile variance from the average, the day-ahead forecast error and the system losses.

Conjecture 2. Constraint (4) in the traditional SCUC formulation schedules sufficient ramping capabilities to cover real-time demand and load variations. $\sum_{i=1}^{N_G} R_i^{max} \geq d(D(t) + L(t))/dt$ and $\sum_{i=1}^{N_G} R_i^{min} \leq d(D(t) + L(t))/dt$.

Counter-Proof: By definition, the range of the scheduled ramping resources are:

$$\left[\sum_{i=1}^{N_G} w_{it} R_i^{min}, \sum_{i=1}^{N_G} w_{it} R_i^{max} \right] \quad (31)$$

According to (3) and (4), these limits become:

$$\sum_{i=1}^{N_G} R_i^{max} \geq \frac{\hat{D}_t - \hat{D}_{t-1}}{T_h} \quad (32)$$

$$\sum_{i=1}^{N_G} R_i^{min} \leq \frac{\hat{D}_t - \hat{D}_{t-1}}{T_h} \quad (33)$$

Now consider a ramping differential $\Delta R(t)$ defined as:

$$\Delta R(t) = \frac{d(D(t) + L(t))}{dt} - \frac{\hat{D}_t - \hat{D}_{t-1}}{T_h} \quad (34)$$

If the maximum ramp capability of the scheduled generation is equal to the difference in successive forecasts, $\sum_{i=1}^{N_G} R_i^{max} = \frac{\hat{D}_t - \hat{D}_{t-1}}{T_h}$ and $\Delta R(t) \geq 0$, then the conjecture is false. Similarly, if the minimum ramp capability of the schedule generation is equal to the difference in successive forecasts, $\sum_{i=1}^{N_G} R_i^{min} = \frac{\hat{D}_t - \hat{D}_{t-1}}{T_h}$ and $\Delta R(t) \leq 0$ then the conjecture is also false. ■

Remark. Rewriting the ramping differential $\Delta R(t)$ in terms of the average demand levels of successive time blocks \bar{D}_t gives:

$$\Delta R(t) = \frac{d(D(t) + L(t))}{dt} - \frac{\hat{D}_t - \hat{D}_{t-1}}{T_h} = \left[\frac{d(D(t))}{dt} - \frac{\bar{D}_t - \bar{D}_{t-1}}{T_h} \right] + \left[\frac{(\bar{D}_t - \hat{D}_t) - (\bar{D}_{t-1} - \hat{D}_{t-1})}{T_h} \right] + \frac{dL(t)}{dt} \quad (35)$$

Similar to the generation scheduling case, the mismatch consists of three terms. The first term is the difference between the real-time demand variations and its day-ahead estimate based on best forecast. The second and third terms are contributed by the day-ahead forecast error and the system losses.

The derivations above show that both generation and ramping mismatches from the real-time values are due to the following three factors:

- **Scheduling time step.** The time resolution of the SCUC problem T_h is normally taken one hour, while the real-time power consumption changes constantly. This makes matching the scheduled and real-time values.
- **Day-ahead forecast error.** The SCUC problem is based on the day-ahead net load forecast, which never matches

its actual value due to the limited accuracy of the forecast. The day-ahead forecast error is the second major contributor to the mismatch.

- **Transmission losses.** Power balance also implies incorporation of the loss term in the equations, while constraint (3) neglects the losses, which also contributes to the mismatch term.

To overcome the limitations of the two false conjectures above, the SCUC formulation is enhanced with three additional constraints (42)-(44):

$$\min \sum_{t=1}^{24} \sum_{i=1}^{N_G} \left(w_{it} C_i^F + C_i^L P_{it} + C_i^Q P_{it}^2 + w_{it}^u C_i^U + w_{it}^d C_i^D \right) \quad (36)$$

$$\text{s.t.} \quad \sum_{i=1}^{N_G} P_{it} = \hat{D}_t \quad (37)$$

$$-R_i^{\max} T_h \leq P_{it} - P_{i,t-1} \leq R_i^{\max} T_h \quad (38)$$

$$w_{it} P_i^{\min} \leq P_{it} \leq w_{it} P_i^{\max} \quad (39)$$

$$w_{it} = w_{i,t-1} + w_{it}^u - w_{it}^d \quad (40)$$

$$\sum_{i=1}^{N_G} w_{it} P_i^{\max} - \sum_{i=1}^{N_G} P_{it} \geq P_{res} \quad (41)$$

$$\sum_{i=1}^{N_G} P_{it} - \sum_{i=1}^{N_G} w_{it} P_i^{\min} \geq P_{res} \quad (42)$$

$$\sum_{i=1}^{N_G} w_{it} R_i^{\max} - \sum_{i=1}^{N_G} \left(\frac{P_{it} - P_{i,t-1}}{T_h} \right) \geq R_{res} \quad (43)$$

$$\sum_{i=1}^{N_G} \left(\frac{P_{it} - P_{i,t-1}}{T_h} \right) - \sum_{i=1}^{N_G} w_{it} R_i^{\min} \geq R_{res} \quad (44)$$

where constraint (42) makes sure that the generation outputs can vary from the scheduled values in both up and down directions. Similarly, the constraints (43) and (44) schedule ramp up and down reserves.

One additional issue concerning operating reserves remains in the utilization of a SCUC for VER integration studies.

Conjecture 3. The amount of scheduled reserves must increase as the reserve requirement increases. Therefore, the potential imbalances caused by net load variability are reduced by a greater reserve requirement.

Counter-proof: Equations (41)-(44) ensure that the scheduled operating reserves are greater than the reserve requirements. The former is written on the left hand side while the latter is written on the right hand side. The simplest counter-example can be a single generator system with $P^{\max} = 100MW$, non-binding ramping capabilities and $\hat{D} = 100MW$. At first, $P_{res} = 10MW$ load following reserve requirement leads to a SCUC solution of $P = 100MW$ with actual reserves of $100MW$. Then, as the reserve requirement increases to $P_{res} = 20MW$, the scheduled generation level still stays the same $100MW$, since it is defined by \hat{D} . Thus, the actual reserves of the system also stay the same. This scenario is observed in the power systems of all sizes and it reveals the main point of this conjecture: the power system operators are only able to set the *reserve requirement*, while the penetration of the VER into the system is supported by

actual reserves. Uncertain interdependency between these two concepts creates discrepancies in the integration studies, where one may conclude that increasing the system reserves does not improve the balancing capabilities of the VER induced power system. A method of overcoming these kind of discrepancies is described in the following remark. ■

Remark. While the right hand side of (41)-(44) can increase continuously, the left hand side can only change discretely with the commitment of new generation units. The degree to which the actual scheduled reserves exceed the reserve requirements depends on different factors including the generation portfolio, the demand level, ramping capabilities, and relative costs. The value will range from zero to the largest generation unit capacity. Therefore, for the same reserve requirement, a power system with mostly larger generation units is likely to maintain higher scheduled reserves. Barring ramping limitations, such a system would maintain significantly lower imbalance levels in VER integration studies.

The counter-proof and remark above suggest that the SCUC needs to be implemented in such a way as to give unbiased, case-independent results as part of a VER integration study. The notion of case-independence assumes that the reserve requirements of the system should be independent of the physical properties of the generators, such as maximum/minimum generation levels and ramping rates. As far as the power system operates according to the model in Fig. 2, the reserve requirement should only be defined by the parameters of the net load and the characteristic times of the power system operations [47]. To that effect, the enhanced SCUC formulation is implemented for the worst-case scenario that the actual scheduled reserves *are equal to* the reserve requirements. In such a way, the enhanced SCUC formulation can help to describe how large the imbalances *can be* for a power system with integrated VERs.

The amount of the scheduled reserves is changed by *artificially* manipulating the maximum and minimum generation levels *after* the generation units have been committed. This is achieved with scaling factors which are defined by the ratio of the reserve requirement to the scheduled reserves:

$$\alpha_t^{PU} = \frac{P_{res}}{\sum_{i=1}^{N_G} w_{it} (P_i^{\max} - P_{it})} \quad (45)$$

$$\alpha_t^{PD} = \frac{P_{res}}{\sum_{i=1}^{N_G} w_{it} (P_{it} - P_i^{\min})} \quad (46)$$

According to (45) and (46), the scaling factors depend on time, because the SCUC schedule commits different amount of reserves for different time intervals. The scaling factors are then used to adjust the maximum and minimum outputs of the generators, so that the scheduled reserves are equal to the reserve requirements:

$$P_{it}^{\max} = P_{it} + \alpha_t^{PU} \cdot (P_i^{\max} - P_{it}) \quad (47)$$

$$P_{it}^{\min} = P_{it} - \alpha_t^{PD} \cdot (P_{it} - P_i^{\min}) \quad (48)$$

Note, that the maximum and minimum outputs of the committed generators change over time. While this process is just

a mathematical abstraction, it is required to demonstrate the impact of the reserve requirements on the system imbalances.

The same rationale is applied to the scheduling of ramping reserves. Since the generation units normally have the same ramping limits in both directions, only one set of scaling factors are used for ramping capabilities:

$$\alpha_t^R = \frac{R_{res}}{\sum_{i=1}^{N_G} w_{it} (R_i^{max} - R_{it})} \quad (49)$$

Accordingly, the adjusted maximum and minimum ramping rates of the generators are given by the following equations:

$$R_{it}^{max} = R_{it} + \alpha_t^R \cdot (R_i^{max} - R_{it}) \quad (50)$$

$$R_{it}^{min} = R_{it} - \alpha_t^R \cdot (R_i^{max} - R_{it}) \quad (51)$$

B. Balancing Actions

Once the first layer of the enterprise control in Fig. 2 has been described, this section turns to describing the (middle) balancing layer. It performs two actions: the economic dispatch and the manual operator actions.

1) *Security-Constrained Economic Dispatch*: The real-time market is based on the SCED problem given in (8)-(13). However, that formulation always equates the changes in generation to the changes in demand; leaving the current imbalances untouched. Furthermore, the SCED as stated does not replace utilized regulation reserves with firm capacity. As a result, the regulation service can potentially saturate quickly; leaving the system to be protected by only manual operation. To avoid these issues, the proposed methodology modifies the power balance constraint (10) such that the enhanced SCED formulation is:

$$\min \sum_{i=1}^{N_G} (C_i^L \Delta P_{it} + 2C_i^Q P_{it} \Delta P_{it}) \quad (52)$$

$$\text{s.t.} \quad \Delta P_{jt} = \sum_{i=1}^{N_G} B_{ji} \Delta P_{it} \quad (53)$$

$$\sum_{j=1}^{N_B} (1 - \gamma_{jt}) (\Delta P_{jt} - \Delta \hat{D}_{jt}) = I_t + G_t \quad (54)$$

$$\sum_{j=1}^{N_B} a_{ljt} (\Delta P_{jt} - \Delta \hat{D}_{jt}) \leq F_l^{max} - F_{lt} \quad (55)$$

$$-R_i T_m \leq \Delta P_{it} \leq R_i T_m \quad (56)$$

$$P_{it} - P_i^{min} \leq \Delta P_{it} \leq P_i^{max} - P_{it} \quad (57)$$

where I_t is the current level of imbalances and G_t is the current level of utilized regulation reserves.

2) *Operator Manual Actions*: In the normal operating mode, the regulation service and the real-time market are able to keep the system balanced. However, a sudden outage of a major generation unit creates a big imbalance that the real-time market and regulation service are not able to mitigate. These kinds of situations require manual actions in the form of contingency reserves deployment, decisions on the location of activated resources, etc. Manual actions are performed by power system operators and are performed as necessary. In the absence of operator models in the literature, the following

method is used in the current study. The trigger of operator manual intervention works when the imbalance exceeds 80% of the largest generation unit. The actions of the operators include balancing of the system by bringing new generation units online.

C. Regulation Service Model

The regulation service is provided by generation units controlled by the dynamic AGC model described in Section II-C. This study uses 1 minute increments as its finest time scale resolution. In the meantime, the cycle time of slow transient stability phenomena is approximately 10 seconds. Given the 6x difference, the transfer function shown in Fig. 1 can be replaced with the steady-state equivalent of a gain with saturation limits. In implementation, the regulation service responds to the imbalance by moving its output to the opposite direction until imbalance mitigation or regulation service saturation. Also, according to (16), the ACE estimation requires the measurement of the system frequency deviation. However, for steady-state simulations the concept of frequency is not applicable. Instead, a designated *virtual* slack generator consumes the mismatch of generation and consumption to make the steady-state power flow equations solvable. Therefore, for steady state simulations the power system imbalance is measured at the slack generator output [36].

D. Modeling Variable Energy Resources

For the simulation of different integration scenarios, VER models should systematically and explicitly vary five main parameters: penetration level, capacity factor, variability, day-ahead and short-term forecast errors.

First, the definitions of VER penetration level and capacity factor in (18) and (19) respectively can be used to define the actual VER output.

$$P_V(t) = \frac{P_V(t) \overline{P_V(t)}}{\overline{P_V(t)} P_V^{max}} \cdot \frac{P_V^{max}}{P_L^{peak}} \cdot P_L^{peak} = p_V(t) \cdot \gamma \cdot \pi \cdot P_L^{peak} \quad (58)$$

where $p_V(t)$ is VER power normalized to a unit capacity factor. Equation (58) shows that if a single $p_V(t)$ is taken as a default profile, the actual VER output can be systematically adjusted with the values of π and γ .

Next, the definition of VER forecast error in (25) can be used to define the actual VER forecast error. Two types of forecasts (and their errors) are used in the power system simulations, day-ahead and short-term. The day-ahead forecast is used in the SCUC model for day-ahead resource scheduling. It normally has a 1 hour resolution and up to 48 hour forecast horizon. The short-term forecast is used in the SCED model for real-time balancing operations. It has a 10 minute time resolution and up to 6 hour time horizon [51], [52]. The VER forecast can be expressed as:

$$\hat{P}_V(t) = P_V(t) - E(t) \quad (59)$$

where $\hat{P}_V(t)$ is the forecasted VER profile, and $E(t)$ is the error term. Using the definition of the forecast error in (25),

the error term can be written as:

$$\begin{aligned} E(t) &= \frac{E(t)}{\text{std}(E(t))} \cdot \frac{\text{std}(E(t))}{P_V^{\max}} \cdot \frac{P_V^{\max}}{P_L^{\text{peak}}} \cdot P_L^{\text{peak}} = \\ &= e(t) \cdot \varepsilon \cdot \pi \cdot P_L^{\text{peak}} \end{aligned} \quad (60)$$

where $e(t)$ is the error term normalized to the unit standard deviation. Equation (60) shows that if a single $e(t)$ is taken for each type of market as a default profile, the actual error profile can be systematically adjusted with the values of π and ε . It is important to emphasize that the $e(t)$ is different for the day-ahead and short-term applications. They may have different probability distributions and power spectra. Additionally, the forecast error ranges are generally different with the short-term forecast having higher accuracy as compared to the day-ahead forecast.

Finally, the actual variability can be similarly adjusted with the value of α . Using (58) and (60) and the properties of variability in (21) and (23), the VER model can be expressed as follows:

$$P_V(t) = p_V(\alpha t) \cdot \gamma \cdot \pi \cdot P_L^{\text{peak}} \quad (61)$$

$$\hat{P}_V(t) = (\gamma \cdot p_V(\alpha t) - \varepsilon \cdot e(\alpha t)) \cdot \pi \cdot P_L^{\text{peak}} \quad (62)$$

$$\alpha = A/A_0 \quad (63)$$

This set of equations defines the VER model used in this study. As an input, it requires the actual VER profile $p_V(t)$ normalized to unit capacity factor, and the error term profile $e(t)$, normalized to unit standard deviation. The model explicitly includes the five major parameters of VER.

IV. METHOD VALIDATION

The purpose of this section is to compare the performances of the enterprise control and classical methods for different power systems. All power systems used in this section are slight modifications of IEEE RTS-96 reliability test system [53]. They differ by the physical properties of the generators, i.e., maximum/minimum generation levels and ramping rates. The goal is to show that the enterprise control method provides case-independent results as it is defined in Section III. Also, this section tests the performance of the enterprise control method for the cases when the assumptions in Conjecture 1–3 are not true. Finally, the effect of multi-layer integration on the computational complexity is considered. To this end, six case studies are performed:

- 1) **Downward load following reserve scheduling.** The performances of different power systems with and without constraint (42) are compared.
- 2) **Ramping reserve scheduling.** The performances of different power systems with and without constraints (43) and (44) are compared.
- 3) **Reserve scaling.** The importance of reserve scaling (47), (48), (50) and (51) for case-independent assessment of the reserve requirements is demonstrated.
- 4) **Regulation and imbalance integration into SCED.** The performances of different power systems with and without I_t and G_t terms in constraint (54) are compared.

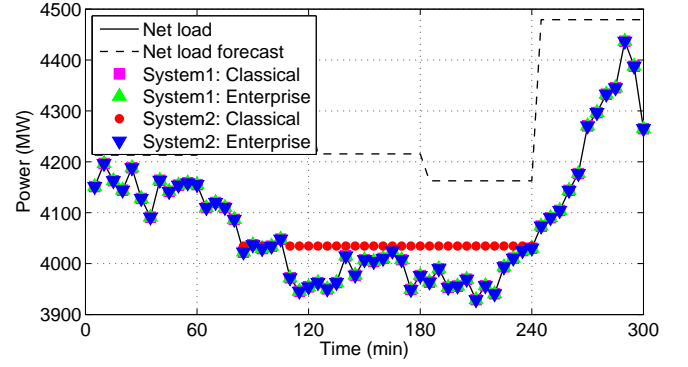

Fig. 3. The impact of down load following reserve scheduling on power system balancing performance.

- 5) **Balancing performance criterion.** Standard deviation of imbalance is compared to control performance standard as a balancing performance criterion.
- 6) **Computational complexity.** The computational complexity of the enterprise control method is tested.

The data for load and VER daily profiles are taken from Bonneville Power Administration (BPA) repositories [54].

A. Downward Load Following Reserve Scheduling

Two power systems are studied, where the minimum power limits of the first system's generators are close to zero, while for the second system these numbers are significantly higher. Both systems are simulated for SCUC formulations with (enterprise) and without (classical) constraint (42). The results in Fig. 3 show that for the first system both methods perform well and the generation follows the actual demand. Note that the equivalence of the two methods is demonstrated by the superimposed purple squares, green triangles and blue triangles. Constraint (42) is not binding and both methods yield the same generation commitment. However, for the second system, the generation scheduled by the classical method hits the minimum level and is unable to meet the actual demand. It should be noted, the the forecasted demand is higher than the minimum generation level and constraint (39) still holds. For the enterprise control method, constraint (42) becomes binding and the commitment changes to allow generation dispatchability in both directions. As a result, the enterprise control method is able to meet the demand for the second system as well.

B. Ramping Reserve Scheduling

Two power systems are studied, where the generation units of the first system have high ramping capabilities, while the second system is mainly composed of slow-moving generators. Both systems are simulated for SCUC formulations with (enterprise) and without (classical) constraints (43) and (44). The simulation in Fig. 4 show that for the first system both methods perform well and the generation follows the actual demand. Constraints (43) and (44) are not binding and both methods yield the same generation commitment. However, the generation scheduled by the classical method experiences

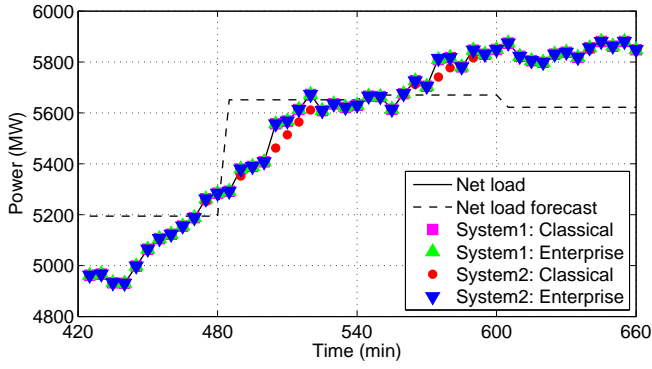

Fig. 4. The impact of ramping reserve scheduling on power system balancing performance

ramping limitations for the second system and is unable to meet the actual demand. For example, at $t = 510\text{min}$, the red circles fail to track the net load curve by about 50MW . It should be noted, that the forecasted generation change during those intervals is nearly negligible and constraint (38) still holds. For the enterprise control method, constraints (43) and (44) become binding and the commitment changes to allow higher generation flexibility. As a result, the enterprise control method is able to meet the demand for the second system as well.

C. Reserve Scaling

As already mentioned above, the actually scheduled reserve amount is often higher than the reserve requirement in (41), depending on the size of generation units. The purpose of reserve scaling in (47), (48), (50) and (51) is to match the required and actual reserves, providing worst-case scenario results. Three power systems with different sets of generators are studied. The first system mainly consists of small generation units. The generators of the second system are larger compared to the ones of the first system. Finally, the third system has the largest units of all three. These three systems are simulated without (classical) and with (enterprise) reserve scaling. The results in Fig. 5 show that the reserve requirement assessment results for the classical method are different for each system, i.e., they are case-dependent, while the results for the enterprise control method match for all three systems. The fact that the enterprise control assessment method yields higher reserve requirement results may be misleading. However, the *actual* reserves for the classical method exceed the reserve requirements by a large amount, which can be concluded from the corresponding low levels of imbalances. In contrast, the enterprise control method matches the required and actual reserves and returns the absolute necessary amount of reserves for keeping any system with the given net load profile balanced, which is the reserve requirement by definition. Thus, the enterprise control method provides a case-independent assessment of reserve requirement.

D. Regulation and Imbalance Integration into the SCED

The role of the regulation service is to mitigate the short-term imbalances. Since imbalance mitigation also reduces the

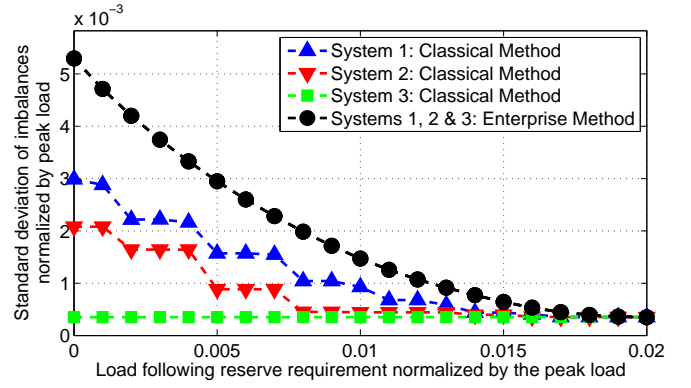

Fig. 5. The impact of reserve scaling on the adequacy of the load following reserve requirement assessment

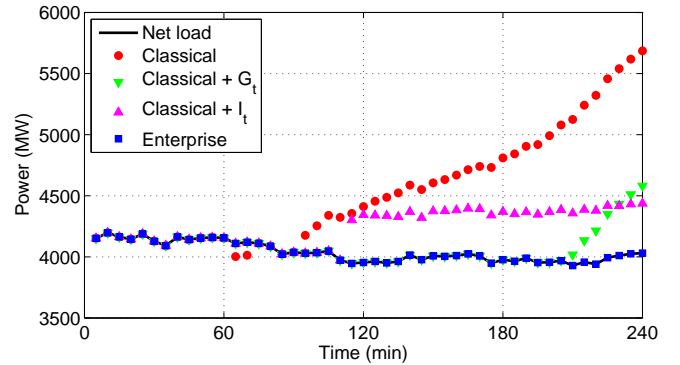

Fig. 6. The impact of the regulation and imbalance integration into the SCED on the power system balancing performance

available regulation capacity, the *effective imbalance* is split between the deployed regulation and the measured residual imbalance. To this end, I_t and G_t terms are incorporated into constraint (54) to reset the *effective imbalance* and avoid regulation saturation or accumulation of residual imbalance. The advantages of this method are demonstrated by a set of simulations for four variations of constraint (54): classical, classical + I_t , classical + G_t and enterprise control, as shown in Fig. 6. For the classical method the regulation goes to saturation quickly and leaves the system without protection. As a result, the unmitigated imbalance starts accumulating and the system loses stability. The presence of the G_t term alone periodically resets the utilized regulation and allows partial mitigation of the imbalance. However, the residual imbalance starts accumulating and the system loses stability soon. The presence of the I_t term alone mitigates the residual imbalance, while the regulation remains saturated and an imbalance equal to the forecast error emerges. Finally, the enterprise control method with both I_t and G_t terms is able to maintain the system balanced.

E. Balancing Performance Criterion

A proper choice of balancing performance criterion is important for this study since it should reasonably reflect the impact of changing reserve requirements on the imbalances. Although the control performance standard (CPS) described in

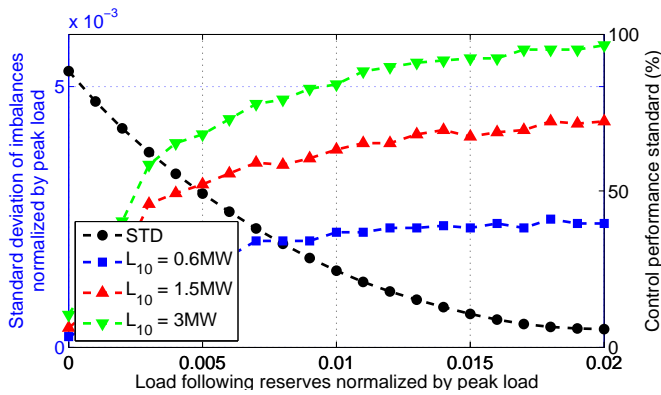

Fig. 7. The CPS value for various L_{10} thresholds compared to the STD value for different load following reserve amount

Section II-C is a well-established criterion for power system balance diagnosis, its use for this study is limited for the following reasons. Being a function of imbalances (ACE), the CPS only defines the percentage of intervals with residual imbalances, while the actual magnitude of imbalances is ignored. This may bring about misleading results about the impact of reserve requirements on the imbalances. As shown in Fig. 7, with increase of reserve requirements the magnitude of imbalances (the standard deviation) reduces monotonically. However, the curves for CPS are not monotonic and at some points the value of CPS even decreases with increase of reserve requirements. These results are hard to interpret. Also, the CPS value depends on system-specific L_{10} threshold whose value varies for different systems (Fig. 7). This further complicates the interpretation of the CPS value. To avoid these issues, the standard deviation of imbalances is used as a balancing performance criterion.

F. Computational Complexity

The computational complexities of the enterprise control and sole generation dispatching methods are compared. While the SCUC, reserve scaling and regulation contribute to the computational complexity of the enterprise control, the test simulations show that their impact is insignificant. One day simulation of power system operations with generation dispatch lasts 183.38 seconds on a Core i5 machine, while with enterprise control it takes 188.83 seconds, only 3% more. This is due to the fact, that SCUC optimization runs only once daily and regulation and reserve scaling are simple algebraic manipulations. The SCED takes the most computational burden, since it runs an optimization problem every 5 minutes.

V. CONCLUSION

This paper proposes an enterprise control assessment method for variable energy resource induced power system imbalances. Its distinguishing feature as compared to methodologies in the existing literature is a holistic approach. It consists within a single package a three layer enterprise control simulator which includes most of the balancing operation functionality found in traditional power systems. These include a resource scheduling layer, a balancing layer, and physical

power grid layer. Wherever possible, existing models such as SCUC, SCED and AGC have been used; although some modifications have been made to overcome some of their implicit methodological limitations. The paper is concluded with a set of validating simulations that demonstrate the importance of the implemented modifications. The sequel to this paper submitted to the same issue provides a set of extensive results that demonstrate how power grid balancing operations systematically address variable energy resource integration.

REFERENCES

- [1] E. A. DeMeo, W. Grant, M. R. Milligan, and M. J. Schuerger, "Wind plant integration: Costs, Status, and Issues," *IEEE Power Energy Mag.*, vol. 3, no. 6, pp. 38–46, 2005.
- [2] J. C. Smith, M. R. Milligan, E. A. DeMeo, and B. Parsons, "Utility Wind Integration and Operating Impact State of the Art," *IEEE Trans. Power Syst.*, vol. 22, no. 3, pp. 900–908, 2007.
- [3] O. Edenhofer, L. Hirth, B. Knopf, M. Pahle, S. Schlömer, E. Schmid, and F. Ueckerdt, "On the economics of renewable energy sources," *Energy Economics*, vol. 40, Supple, no. 0, pp. S12–S23, Dec. 2013.
- [4] E. Ela, B. Kirby, E. Lannoye, M. Milligan, D. Flynn, B. Zavadil, and M. O'Malley, "Evolution of operating reserve determination in wind power integration studies," in *IEEE Power and Energy Society General Meeting 2010*, 2010, pp. 1–8.
- [5] H. Holttinen, M. Milligan, E. Ela, N. Menemenlis, J. Dobschinski, B. Rawn, R. J. Bessa, D. Flynn, E. Gomez-Lazaro, and N. K. Detlefsen, "Methodologies to Determine Operating Reserves Due to Increased Wind Power," *IEEE Trans. Sustain. Energy*, vol. 3, no. 4, pp. 713–723, 2012.
- [6] C. Yuen, A. Oudalov, and A. Timbus, "The Provision of Frequency Control Reserves From Multiple Microgrids," *IEEE Trans. Ind. Electron.*, vol. 58, no. 1, pp. 173–183, 2011.
- [7] K. De Vos and J. Driesen, "Dynamic operating reserve strategies for wind power integration," *IET Renewable Power Generation*, vol. 8, no. 6, pp. 598–610, 2014.
- [8] Z. Zhou and A. Botterud, "Dynamic Scheduling of Operating Reserves in Co-Optimized Electricity Markets With Wind Power," *IEEE Trans. Power Syst.*, vol. 29, no. 1, pp. 160–171, 2014.
- [9] A. Ahmadi-Khatir, A. J. Conejo, and R. Cherkaoui, "Multi-Area Unit Scheduling and Reserve Allocation Under Wind Power Uncertainty," *IEEE Trans. Power Syst.*, vol. 29, no. 4, pp. 1701–1710, 2014.
- [10] A. M. Farid and A. Muzhikyan, "The Need for Holistic Assessment Methods for the Future Electricity Grid," in *GCC Power 2013 Conference & Exhibition*, Abu Dhabi, UAE, 2013, pp. 1–13.
- [11] A. M. Farid, B. Jiang, A. Muzhikyan, and K. Youcef-Toumi, "The Need for Holistic Enterprise Control Assessment Methods for the Future Electricity Grid," in *World Wind Integration Study Report*. Bonn: World Wind Energy Association, 2014.
- [12] A. Robitaille, I. Kamwa, A. Oussedik, M. de Montigny, N. Menemenlis, M. Huneault, A. Forcione, R. Mailhot, J. Bourret, and L. Bernier, "Preliminary Impacts of Wind Power Integration in the Hydro-Quebec System," *Wind Engineering*, vol. 36, no. 1, pp. 35–52, Feb. 2012.
- [13] T. Aigner, S. Jaehnert, G. L. Doorman, and T. Gjengedal, "The Effect of Large-Scale Wind Power on System Balancing in Northern Europe," *IEEE Trans. Sustain. Energy*, vol. 3, no. 4, pp. 751–759, 2012.
- [14] M. H. Albadi and E. F. El-Saadany, "Comparative study on impacts of wind profiles on thermal units scheduling costs," *IET Renewable Power Generation*, vol. 5, no. 1, pp. 26–35, 2011.
- [15] D. A. Halamay, T. K. A. Brekken, A. Simmons, and S. McArthur, "Reserve Requirement Impacts of Large-Scale Integration of Wind, Solar, and Ocean Wave Power Generation," *IEEE Trans. Sustain. Energy*, vol. 2, no. 3, pp. 321–328, 2011.
- [16] J. Apt, "The spectrum of power from wind turbines," *Journal of Power Sources*, vol. 169, no. 2, pp. 369–374, June 2007.
- [17] A. E. Curtright and J. Apt, "The character of power output from utility-scale photovoltaic systems," *Progress in Photovoltaics: Research and Applications*, vol. 16, no. 3, pp. 241–247, May 2008.
- [18] H. Holttinen, M. Milligan, B. Kirby, T. Acker, V. Neimane, and T. Molinski, "Using Standard Deviation as a Measure of Increased Operational Reserve Requirement for Wind Power," *Wind Engineering*, vol. 32, no. 4, pp. 355–377, 2008.

- [19] P. J. Luickx, E. D. Delarue, and W. D. D'haeseleer, "Effect of the generation mix on wind power introduction," *IET Renewable Power Generation*, vol. 3, no. 3, pp. 267–278, 2009.
- [20] C. W. Hansen and A. D. Papalexopoulos, "Operational Impact and Cost Analysis of Increasing Wind Generation in the Island of Crete," *IEEE Syst. J.*, vol. 6, no. 2, pp. 287–295, 2012.
- [21] K. Bruninx and E. Delarue, "A Statistical Description of the Error on Wind Power Forecasts for Probabilistic Reserve Sizing," *IEEE Trans. Sustain. Energy*, vol. 5, no. 3, pp. 995–1002, 2014.
- [22] B. C. Ummels, M. Gibescu, E. Pelgrum, W. L. Kling, and A. J. Brand, "Impacts of Wind Power on Thermal Generation Unit Commitment and Dispatch," *IEEE Trans. Energy Convers.*, vol. 22, no. 1, pp. 44–51, 2007.
- [23] Y. V. Makarov, P. V. Etingov, and J. Ma, "Incorporating Uncertainty of Wind Power Generation Forecast Into Power System Operation, Dispatch, and Unit Commitment Procedures," *IEEE Trans. Sustain. Energy*, vol. 2, no. 4, pp. 433–442, 2011.
- [24] Y. V. Makarov, C. Loutan, J. Ma, and P. de Mello, "Operational Impacts of Wind Generation on California Power Systems," *IEEE Trans. Power Syst.*, vol. 24, no. 2, pp. 1039–1050, 2009.
- [25] R. Billinton and G. Bai, "Generating capacity adequacy associated with wind energy," *IEEE Trans. Energy Convers.*, vol. 19, no. 3, pp. 641–646, 2004.
- [26] A. Muzhikyan, A. M. Farid, and K. Youcef-Toumi, "Variable energy resource induced power system imbalances: A generalized assessment approach," in *IEEE Conference on Technologies for Sustainability (SusTech) 2013*, Portland, OR, 2013, pp. 250–257.
- [27] A. Muzhikyan, A. M. Farid, and K. Youcef-Toumi, "Variable energy resource induced power system imbalances: Mitigation by increased system flexibility, spinning reserves and regulation," in *IEEE Conference on Technologies for Sustainability (SusTech) 2013*, Portland, OR, 2013, pp. 15–22.
- [28] P. Martin, "The Need for Enterprise Control," *InTech*, vol. Nov/Dec, pp. 1–5, 2012.
- [29] ANSI/ISA-95, "Enterprise-Control System Integration - Part 1: Models and Terminology," Tech. Rep.
- [30] A. M. Farid, "Holistic Assessment for Enterprise Control of the Future Electricity Grid," in *IEEE Smart Grid Newsletter*, 2013.
- [31] M. D. Ilic, "From Hierarchical to Open Access Electric Power Systems," *Proc. IEEE*, vol. 95, no. 5, pp. 1060–1084, 2007.
- [32] K. Heussen, "Control Architecture Modeling for Future Power Systems," PhD Thesis, Technical University of Denmark, 2011.
- [33] K. Heussen, S. Koch, A. Ulbig, and G. Andersson, "Unified System-Level Modeling of Intermittent Renewable Energy Sources and Energy Storage for Power System Operation," *IEEE Syst. J.*, vol. 6, no. 1, pp. 140–151, 2012.
- [34] A. A. Thatte and L. Xie, "Towards a Unified Operational Value Index of Energy Storage in Smart Grid Environment," *IEEE Trans. Smart Grid*, vol. 3, no. 3, pp. 1418–1426, 2012.
- [35] A. Muzhikyan, A. M. Farid, and K. Youcef-Toumi, "An Enterprise Control Assessment Method for Variable Energy Resource Induced Power System Imbalances. Part 2: Parametric Sensitivity Analysis," *IEEE Trans. Ind. Electron.*, to be published.
- [36] A. Gomez-Exposito, A. J. Conejo, and C. Cañizares, *Electric Energy Systems: Analysis and Operation*. Boca Raton, Fla: CRC, 2008.
- [37] P. Kundur, N. J. Balu, and M. G. Lauby, *Power system stability and control: The EPRI power system engineering series*. New York: McGraw-Hill, 1994.
- [38] S. Frank and S. Rebennack, "A Primer on Optimal Power Flow: Theory, Formulation, and Practical Examples," Colorado School of Mines, Tech. Rep. October, 2012.
- [39] J. Carpentier, "Contribution to the economic dispatch problem," *Bull. Soc. Franc. Electr.*, vol. 3, no. 8, pp. 431–447, 1962.
- [40] B. Stott, J. Jardim, and O. Alsac, "DC Power Flow Revisited," *IEEE Trans. Power Syst.*, vol. 24, no. 3, pp. 1290–1300, 2009.
- [41] A. J. Wood and B. F. Wollenberg, *Power generation, operation, and control*, 2nd ed. New York: J. Wiley & Sons, 1996.
- [42] K.-S. Kim, L.-H. Jung, S.-C. Lee, and U.-C. Moon, "Security Constrained Economic Dispatch Using Interior Point Method," in *International Conference on Power System Technology (PowerCon) 2006*, Chongqing, China, 2006, pp. 1–6.
- [43] L. S. Vargas, V. H. Quintana, and A. Vannelli, "A Tutorial Description of an Interior Point Method and Its Applications to Security-Constrained Economic Dispatch," *IEEE Trans. Power Syst.*, vol. 8, no. 3, pp. 1315–1324, 1993.
- [44] H. Saadat, *Power System Analysis*. McGraw-Hill, 1999.
- [45] North American Electric Reliability Corporation, "Reliability Standards for the Bulk Electric Systems of North America," *NERC Reliability Standards Complete Set*, pp. 1–10, 2012.
- [46] C. Wang, Z. Lu, and Y. Qiao, "A Consideration of the Wind Power Benefits in Day-Ahead Scheduling of Wind-Coal Intensive Power Systems," *IEEE Trans. Power Syst.*, vol. 28, no. 99, p. 1, 2012.
- [47] A. Muzhikyan, A. M. Farid, and K. Youcef-Toumi, "An Enhanced Method for the Determination of Load Following Reserves," in *American Control Conference 2014 (ACC2014)*, Portland, OR, 2014, pp. 926–933.
- [48] C. Monteiro, R. Bessa, V. Miranda, A. Botterud, J. Wang, and G. Conzelmann, "Wind Power Forecasting: State-of-the-Art 2009," Argonne National Laboratory, Illinois, Tech. Rep., 2009.
- [49] PJM, "Manual 13: Emergency Operations," in *Operator Manuals*. PJM, 2011.
- [50] PJM, "Operations 101 Training," in *Operator Training Materials*. PJM, 2011.
- [51] G. Giebel, R. Brownsword, G. Kariniotakis, M. Denhard, and C. Draxl, "The State-Of-The-Art in Short-Term Prediction of Wind Power: A Literature Overview," ANEMOS.plus, Tech. Rep., 2011.
- [52] A. Moreno-Munoz, J. de la Rosa, R. Posadillo, and V. Pallares, "Short term forecasting of solar radiation," in *IEEE International Symposium on Industrial Electronics (ISIE) 2008*, Cambridge, UK, 2008, pp. 1537–1541.
- [53] C. Grigg, P. Wong, P. Albrecht, R. Allan, M. Bhavaraju, R. Billinton, Q. Chen, C. Fong, S. Haddad, S. Kuruganty, W. Li, R. Mukerji, D. Patton, N. Rau, D. Reppen, A. Schneider, M. Shahidehpour, and C. Singh, "The IEEE Reliability Test System-1996. A report prepared by the Reliability Test System Task Force of the Application of Probability Methods Subcommittee," *IEEE Trans. Power Syst.*, vol. 14, no. 3, pp. 1010–1020, 1999.
- [54] Bonneville Power Administration, "Wind Generation & Total Load in The BPA Balancing Authority." [Online]. Available: <http://transmission.bpa.gov/business/operations/wind/>



Aramzd Muzhikyan received his Sc.B and Sc.M degrees from Yerevan State University, Yerevan, Armenia, in 2008. He completed his second Sc.M degree at Masdar Institute of Science and Technology, Abu Dhabi, U.A.E, in 2013. He is currently a research assistant in the department of Engineering Systems and Management at Masdar Institute of Science and Technology. His research interests include signal processing, power system optimization, power system operations and renewable energy integration.



Amro M. Farid received his Sc.B and Sc.M degrees from MIT and went on to complete his Ph.D. degree at the Institute for Manufacturing within the University of Cambridge Engineering Department in 2007. He is currently an assistant professor of Engineering Systems and Management and leads the Laboratory for Intelligent Integrated Networks of Engineering Systems (LI²NES) at Masdar Institute of Science and Technology, Abu Dhabi, U.A.E. He is also a research affiliate at the Massachusetts Institute of Technology – Technology and Development Program. He maintains active contributions in the MIT Future of the Electricity Grid study, the IEEE Control Systems Society, and the MIT-MI initiative on the large-scale penetration of renewable energy and electric vehicles. His research interests generally include the system architecture, dynamics and control of power, water, transportation and manufacturing systems.



Kamal Youcef-Toumi joined the MIT Mechanical Engineering Department faculty in 1986. He earned his advanced degrees (M.S. 1981 and Sc.D. 1985) in Mechanical Engineering from MIT. Professor Youcef-Toumi's research has focused primarily on design, modeling, simulation, instrumentation, and control theory. The applications have included manufacturing, robotics, automation, metrology and nano/biotechnology. He teaches courses in the fields of dynamic systems and controls; robotics; and precision machine design and automatic control systems. He is the Co-Director of the Center for Clean Water and Clean Energy at MIT and KFUPM.