

2005-12-01

## An evolving view of the eukaryotic oligosaccharyltransferase

Daniel J. Kelleher  
*University of Massachusetts Medical School*

*Et al.*

Let us know how access to this document benefits you.

Follow this and additional works at: <https://escholarship.umassmed.edu/oapubs>



Part of the [Biochemistry Commons](#), and the [Pharmacology, Toxicology and Environmental Health Commons](#)

---

### Repository Citation

Kelleher DJ, Gilmore R. (2005). An evolving view of the eukaryotic oligosaccharyltransferase. Open Access Publications by UMass Chan Authors. <https://doi.org/10.1093/glycob/cwj066>. Retrieved from <https://escholarship.umassmed.edu/oapubs/615>

This material is brought to you by eScholarship@UMassChan. It has been accepted for inclusion in Open Access Publications by UMass Chan Authors by an authorized administrator of eScholarship@UMassChan. For more information, please contact [Lisa.Palmer@umassmed.edu](mailto:Lisa.Palmer@umassmed.edu).

## REVIEW

# An evolving view of the eukaryotic oligosaccharyltransferase

Daniel J. Kelleher and Reid Gilmore<sup>1</sup>

Department of Biochemistry and Molecular Pharmacology, University of Massachusetts Medical School, Worcester, MA 01605-2324

Accepted on November 23, 2005

**Asparagine-linked glycosylation (ALG) is one of the most common protein modification reactions in eukaryotic cells, as many proteins that are translocated across or integrated into the rough endoplasmic reticulum (RER) carry N-linked oligosaccharides. Although the primary focus of this review will be the structure and function of the eukaryotic oligosaccharyltransferase (OST), key findings provided by the analysis of the archaeobacterial and eubacterial OST homologues will be reviewed, particularly those that provide insight into the recognition of donor and acceptor substrates. Selection of the fully assembled donor substrate will be considered in the context of the family of human diseases known as congenital disorders of glycosylation (CDG). The yeast and vertebrate OST are surprisingly complex heterooligomeric proteins consisting of seven or eight subunits (Ost1p, Ost2p, Ost3p/Ost6p, Ost4p, Ost5p, Stt3p, Wbp1p, and Swp1p in yeast; ribophorin I, DAD1, N33/IAP, OST4, STT3A/STT3B, Ost48, and ribophorin II in mammals). Recent findings from several laboratories have provided overwhelming evidence that the STT3 subunit is critical for catalytic activity. Here, we will consider the evolution and assembly of the eukaryotic OST in light of recent genomic evidence concerning the subunit composition of the enzyme in diverse eukaryotes.**

*Key words:* dolichol/endoplasmic reticulum/N-linked oligosaccharide/oligosaccharyltransferase

## Introduction

In eukaryotic cells, a critical step in asparagine-linked glycosylation (ALG) of proteins is catalyzed by the oligosaccharyltransferase (OST), an integral membrane protein that mediates the en bloc transfer of a preassembled high-mannose oligosaccharide onto asparagine residues of nascent polypeptides entering the lumen of the rough endoplasmic reticulum (RER). The dolichol pyrophosphate-linked oligosaccharide (OS-PP-Dol) donor (Glc<sub>3</sub>Man<sub>9</sub>GlcNAc<sub>2</sub>-PP-Dol in higher eukaryotes) for glycosylation is sequentially assembled by glycosyltransferases located on the cytoplas-

mic and luminal faces of the RER membrane. The assembly pathway for dolichol oligosaccharides has been reviewed in detail (Burda and Aeby, 1999), so here we will focus on recent discoveries that impact donor-substrate recognition, selection and catalysis by the OST. Although the OST has been the focus of a several reviews during the past decade (Silberstein and Gilmore, 1996; Knauer and Lehle, 1999; Dempski and Imperiali, 2002; Yan and Lennarz, 2005), recent developments in this field make this review timely.

N-Linked glycosylation of nascent glycoproteins is temporally coupled to the protein translocation reaction that occurs as, or immediately after, the polypeptide is synthesized. The coordination of N-linked glycosylation and protein translocation necessitates a spatial localization of the OST adjacent to the protein translocation channel. Even though the OST has unrestricted access to nascent polypeptides entering the ER lumen, a surprising percentage of consensus glycosylation sites are not modified in vivo. Here, we review the effect of acceptor peptide sequence as well as sequence context factors that influence N-linked glycosylation of N-X-T/S sites in vivo and in vitro.

The elucidation of the roles of the noncatalytic OST subunits remains an important issue. In this article, we review the biochemical and genetic characterization of the yeast and mammalian OST subunits, in the context of emerging information about the evolution of the OST that is being deduced from genomics data. Potential roles for several subunits can now be proposed based upon the available data and upon the differences in the enzymatic properties of the OST in diverse organisms.

## Ancient origin of N-linked glycosylation

N-Linked glycosylation of proteins was initially thought to be restricted to eukaryotic organisms. The first evidence that this was not the case came from the structural analysis of alkali-insensitive glycopeptides derived from *Halobacterium* cell surface glycoprotein (CSG) and flagellins (for a review, see Lechner and Wieland, 1989). These *Halobacterium salinarum* proteins are modified with tetrasaccharides composed of glucose and sulfated glucuronic and iduronic acids that are linked to asparagine residues through glucose (Wieland *et al.*, 1983, 1985). The glycosylated asparagines are in an N-X-T/S motif that matches the sequon for N-linked glycosylation in eukaryotic organisms (Wieland *et al.*, 1985). Furthermore, a dolichol-phosphate-linked tetrasaccharide serves as the oligosaccharide donor for N-linked glycosylation in *H. salinarum* (Lechner *et al.*,

<sup>1</sup>To whom correspondence should be addressed; e-mail: reid.gilmore@umassmed.edu

1985). A second glycosaminoglycan-like oligosaccharide is attached to the *H. salinarum* CSG through an asparaginyl-*N*-acetylgalactosamine linkage at an N-A-S site (Paul *et al.*, 1986) using a dolichol-pyrophosphate-linked oligosaccharide as a donor (Lechner and Wieland, 1989). In contrast to what we know about the acceptor-substrate specificity for the eukaryotic OST, addition of the glycosaminoglycan-like oligosaccharide to CSG still occurred when the serine in the N-A-S sequon was replaced with a valine or leucine residue (Zeitler *et al.*, 1998). Thus, in *H. salinarum*, two structurally different N-linked oligosaccharides are attached to N-X-S/T sites by what are likely distinct enzymes based upon differences in donor substrate structure and acceptor substrate specificity. The flagellins of *Methanococcus voltae* are N-glycosylated at multiple N-X-T/S sites with a trisaccharide through an asparaginyl- $\beta$ -GlcNAc linkage (Voisin *et al.*, 2005). The most abundant oligosaccharide donor in *Haloferax volcanii* is mannosyl-( $\beta$ 1-4)galactosyl phosphodolichol (Kuntz *et al.*, 1997). Taken together, it appears that donor substrates for N-glycosylation in archaeobacterial organisms are structurally diverse, yet are assembled upon dolichol phosphate or dolichol pyrophosphate carriers.

Recent evidence indicates that several eubacteria, including *Campylobacter jejuni*, have acquired a 14-gene *pgl* (protein glycosylation) operon that is involved in N-linked glycosylation of cell surface proteins. Protein sequence analysis of the *pgl* operon (Szymanski *et al.*, 1999) revealed that PglB is homologous to the STT3 subunit of the eukaryotic OST. Mutagenesis of the *pglB* locus and chemical deglycosylation of *C. jejuni* membrane proteins led to the conclusion that the *pgl* operon is involved in protein glycosylation (Szymanski *et al.*, 1999). We refer the reader to a recent review of eubacterial glycosylation for more information concerning the roles of the *pgl* gene products in the assembly pathway of the undecaprenyl-pyrophosphate-linked oligosaccharide donor for N-linked glycosylation in eubacteria (Szymanski and Wren, 2005).

### Oligosaccharide donors for the eukaryotic OST

In eukaryotic organisms, the oligosaccharide donor for N-linked glycosylation of proteins is assembled on the carrier lipid dolichol pyrophosphate by the sequential addition of the monosaccharides GlcNAc, Man, and Glc (Figure 1). Chemically synthesized donor substrate analogues that replace dolichol-PP with phytanyl-PP, dihydrofarnesyl-PP, or citronellyl-PP are not substrates for the OST (Fang *et al.*, 1995), but polyprenol-PP-linked oligosaccharides are utilized as donors in the Chinese hamster ovary cell line B211 (Kaiden *et al.*, 1998).

The assembly pathway for  $\text{Glc}_3\text{Man}_9\text{GlcNAc}_2\text{-PP-Dol}$  has been deduced from the analysis of intermediates that accumulate in vitro in membranes from wild-type cells (Chapman *et al.*, 1979; Liu *et al.*, 1979) and by the analysis of the yeast *alg* mutants that lack glycosyltransferase activities (Huffaker and Robbins, 1983; Burda and Aebi, 1999). Most of the glycosyltransferases (ALG proteins) that mediate  $\text{Glc}_3\text{Man}_9\text{GlcNAc}_2\text{-PP-Dol}$  assembly have now been identified (Figure 1). OS-PP-Dol assembly initiates on the cytoplasmic face of the RER, where sugar nucleotides (UDP-GlcNAc

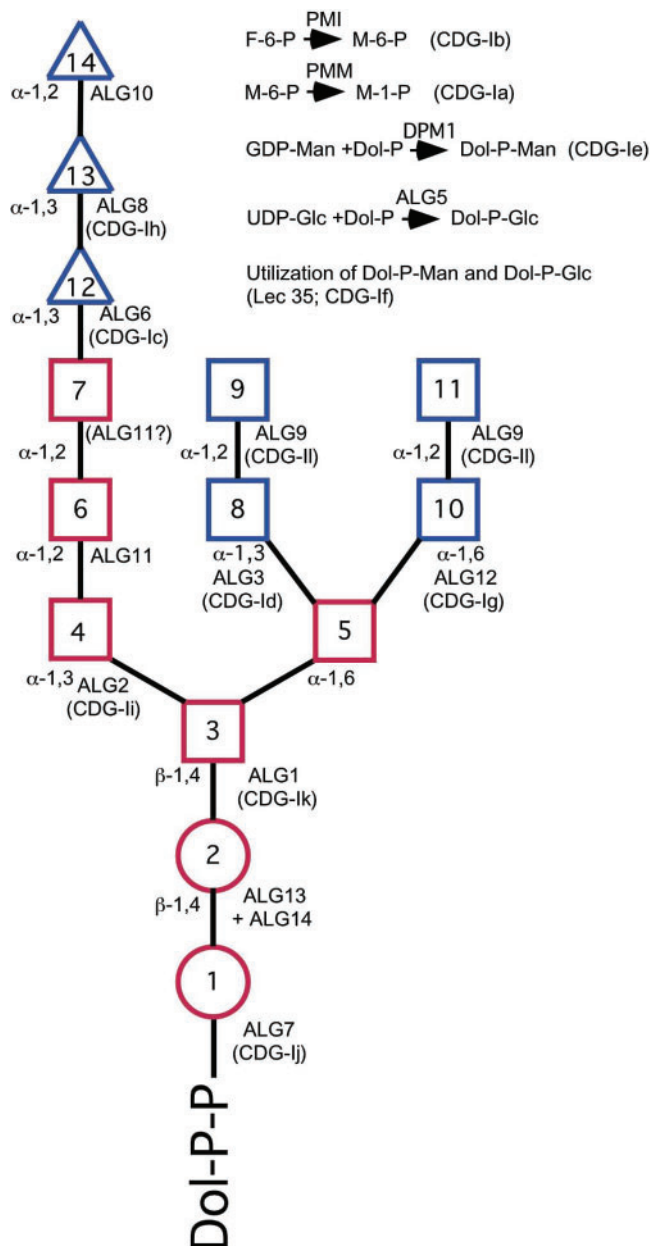

**Fig. 1.** The structure and assembly pathway for eukaryotic dolichol-linked oligosaccharides. GlcNAc residues are designated by circles, mannose residues by squares, and glucose residues by triangles. Numbers within saccharide units designate the order of saccharide addition. Red residues are transferred to the dolichol-pyrophosphate carrier on the cytoplasmic face of the RER, blue residues are added on the luminal side. The yeast gene(s) that encodes each glycosyltransferase is indicated if known. Currently described subtypes of CDG-1 are identified by the step in OS-PP-Dol assembly that is affected. The role of Alg11p in transfer of residue 7 is uncertain at this time.

and GDP-Man) serve as the saccharide donors for the addition of the first seven residues (Figure 1, red symbols) to yield  $\text{Man}_5\text{GlcNAc}_2\text{-PP-Dol}$ . The initial step in OS-PP-Dol assembly is catalyzed by *N*-acetylglucosaminyl phosphate transferase (ALG7) that forms the phosphodiester linkage between GlcNAc-1-phosphate (derived from UDP-GlcNAc) and dolichol-monophosphate.

The most recently identified glycosyltransferase in the OS-PP-Dol assembly pathway is the ALG13–14 heterodimer that mediates the addition of the second GlcNAc residue to form Dol-PP-GlcNAc<sub>2</sub> (Bickel *et al.*, 2005; Chantret *et al.*, 2005; Gao *et al.*, 2005). Dol-PP-GlcNAc<sub>2</sub> is the *in vivo* oligosaccharide donor for N-linked glycosylation in *Giardia lamblia* (Samuelson *et al.*, 2005). The yeast or vertebrate OST will utilize Dol-PP-GlcNAc<sub>2</sub> as a donor substrate in an *in vitro* assay (Sharma *et al.*, 1981; Imperiali and Shannon, 1991). The importance of the two *N*-acetyl moieties in Dol-PP-GlcNAc<sub>2</sub> has been investigated using several synthetic dolichol-linked oligosaccharides (Tai and Imperiali, 2001). Dol-PP-GlcNAc-Glc, like the minimal *in vivo* donor Dol-PP-GlcNAc<sub>2</sub>, is a functional donor for the OST, indicating that the 2'-*N*-acetyl modification of the second sugar is not critical for OST recognition and catalysis. Although glycopeptide products bearing a single GlcNAc were detected by mass spectroscopy when Dol-PP-GlcNAc was tested as the donor, Dol-PP-GlcNAc is clearly a very poor donor substrate for the OST (Bause *et al.*, 1995; Tai and Imperiali, 2001). Dol-PP-2-deoxyfluoroglucose-GlcNAc and Dol-PP-*N*-trifluoroacetylglucosamine-GlcNAc are not substrates but are instead OST inhibitors. These results demonstrate that the *N*-acetyl modification on the proximal sugar is critical for OST catalysis, whereas the presence and structure of a second sugar residue (GlcNAc > Glc > no sugar) increases enzyme activity (Tai and Imperiali, 2001).

Until recently, it was not clear whether Alg2 transfers residue 4 (an  $\alpha$ -1,3 linked mannose) or residue 5 (an  $\alpha$ -1,6 linked mannose). Analysis of human ALG2 mutant fibroblasts (congenital disorders of glycosylation-Ii [CDG-Ii]) demonstrated that Alg2 is an  $\alpha$ -1,3 mannosyltransferase (Thiel *et al.*, 2003), which provides the substrate for addition of residue 5 by a currently unidentified mannosyltransferase (Figure 1). Man<sub>3</sub>GlcNAc<sub>2</sub>-PP-Dol accumulates as a major lipid-linked oligosaccharide in yeast *alg11Δ* cells providing evidence that Alg11p is an  $\alpha$ -1,2 mannosyltransferase responsible for the addition of residue 6 (Helenius *et al.*, 2002). Although structural analysis of the protein-linked oligosaccharides synthesized by *alg11Δ* cells had suggested that Alg11p adds residue 7 (Cipollo *et al.*, 2001), the latter analysis is complicated by elongation of the *alg11Δ* assembly intermediate by luminal mannosyltransferases. Given that both residues 6 and 7 are  $\alpha$ -1,2 linked mannose, we speculate that a single enzyme (Alg11p) acts sequentially to mediate both additions. Support for this hypothesis is provided by the absence of a candidate GDP-Man-dependent mannosyltransferase of unknown function encoded by the yeast genome. Man<sub>5</sub>GlcNAc<sub>2</sub>-PP-Dol is then flipped from the cytoplasmic face of the ER into the lumen in a reaction that is dependent upon Rft1 *in vivo* (Helenius *et al.*, 2002).

The dolichol monosaccharides Dol-P-Man and Dol-P-Glc serve as the sugar donors for the three luminal mannosyltransferases (ALG3, ALG12, and ALG9) and three glucosyltransferases (ALG6, ALG8, and ALG10) that sequentially transfer residues 8–14 onto the OS-PP-Dol (Figure 1). The ordered addition of the sugar residues is maintained by the remarkable substrate specificity of the glycosyltransferases. For example, the predominant OS-PP-Dol compound synthesized by the *alg3Δ* yeast mutant is Man<sub>5</sub>GlcNAc<sub>2</sub>-PP-Dol not

Glc<sub>3</sub>Man<sub>5</sub>GlcNAc<sub>2</sub>-PP-Dol or Glc<sub>3</sub>Man<sub>7</sub>GlcNAc<sub>2</sub>-PP-Dol (Verostek *et al.*, 1993; Aebi *et al.*, 1996; Kelleher *et al.*, 2001) indicating that Man<sub>5</sub>GlcNAc<sub>2</sub>-PP-Dol is a poor substrate for the Alg6 and Alg12 enzymes. Additional insight into this step-wise assembly pathway has been provided by the discovery that Alg9 transfers two  $\alpha$ -1,2-linked mannose residues (Figure 1, residues 9 and 11). The first addition yields the Man<sub>7</sub>GlcNAc<sub>2</sub>-PP-Dol intermediate (Burda *et al.*, 1996; Cipollo and Trimble, 2000) that is the substrate for Alg12. Alg9 then adds the ninth and final mannose residue to oligosaccharide donor (Frank and Aebi, 2005).

### Defects in donor assembly are responsible for CDG-I

OS-PP-Dols lacking the terminal glucose residue are less effective donors for the vertebrate and yeast OST both *in vitro* and *in vivo* (Turco *et al.*, 1977; Trimble *et al.*, 1980; Burda and Aebi, 1998; Karaoglu *et al.*, 2001). Enzymatic defects that interfere with the biosynthesis of Glc<sub>3</sub>Man<sub>9</sub>GlcNAc<sub>2</sub>-PP-Dol are responsible for a family of diseases referred to as CDG-I (for a recent review of CDG, see Freeze and Aebi, 2005).

Reductions in phosphomannose isomerase activity (PMI; CDG-Ib), phosphomannomutase activity (PMM, CDG-Ia), and Dol-P-Man synthase activity (CDG-Ie) reduce the biosynthesis of the mannose donors (GDP-mannose and Dol-P-Man), thereby causing an accumulation of diverse assembly intermediates (as reviewed in Aebi and Hennet, 2001). The role of the vertebrate LEC35 gene product in OS-PP-Dol assembly was unclear as Lec35 mutants accumulate Man<sub>5</sub>GlcNAc<sub>2</sub>-PP-Dol (Lehrman and Zeng, 1989) but are not defective in Alg3 activity and have normal levels of Dol-P-Man. Lec35 cells were recently shown to be defective in all aspects of Dol-P-Man and Dol-P-Glc utilization (Anand *et al.*, 2001), hence the LEC35 gene product is now referred to as mannose-P-dolichol utilization (MPDU). Deficiencies in human MPDU are responsible for CDG-If (Kranz *et al.*, 2001; Schenk *et al.*, 2001).

Several recently identified CDG-I subtypes (Figure 1, subtypes Ig, Ih, and Ii) cause the accumulation of an OS-PP-Dol assembly intermediate that is a poor substrate for the OST (Chantret *et al.*, 2002; Frank *et al.*, 2004; Schollen *et al.*, 2004). CDG-Ij, Ik, and Ii are caused by mutations that reduce the activity of early acting glycosyltransferases (ALG7, ALG1, and ALG2), thereby reducing the steady-state pool of Glc<sub>3</sub>Man<sub>9</sub>GlcNAc<sub>2</sub>-PP-Dol that can serve as the oligosaccharide donor (Thiel *et al.*, 2003; Wu *et al.*, 2003; Grubenmann *et al.*, 2004).

### Acceptor substrates and peptide inhibitors of the OST

Sequencing of *N*-glycopeptides derived from eukaryotic glycoproteins established that N-glycosylated asparagine residues are within an N-X-T/S consensus sequon, where X can be any residue except proline (Marshall, 1972). Provided that the N- and C-termini are blocked by reagents that mimic peptide bonds, N-X-T tripeptides are glycosylated by the OST *in vitro* (Welply *et al.*, 1983). N-Glycosylated N-X-C sites are present in human von Willebrand factor and serum protein C (Titani *et al.*, 1986; Miletich and Broze,

1990). In vitro assays using synthetic peptide substrates with internal N-X-T/S/C sites showed that the kinetic parameters of the OST (peptide  $K_m$  and  $V_{max}$ ) are strongly influenced by the side chain in the +2 position relative to asparagine, with N-X-T serving as a better substrate than N-X-S, which is in turn much better than N-X-C (Bause, 1984; Breuer *et al.*, 2001). Peptides containing asparagine analogues have been tested as potential OST substrates and inhibitors. As expected from the sequence of natural glycopeptides, the sequon analogues Q-X-T and D-X-T are neither substrates nor high-affinity inhibitors (Welply *et al.*, 1983; Bause *et al.*, 1995). Of more than a dozen tested peptides wherein asparagine is replaced by an amino acid analogue (Welply *et al.*, 1983; Bause *et al.*, 1995; Xu T., Werner M., *et al.*, 1998),  $\beta$ -hydroxyasparagine was found to yield a low affinity substrate, whereas diaminobutanoic acid (Amb) yielded a promising lead compound for OST inhibitors (Bause *et al.*, 1995), as discussed below.

The yeast and vertebrate OST have a surprisingly low affinity ( $K_p \sim 10\text{--}30 \mu\text{M}$ ) for a synthetic tripeptide substrate (e.g., N-Ac-N-[<sup>125</sup>I]Y-T-NH<sub>2</sub>; Karaoglu *et al.*, 2001; Kelleher *et al.*, 2003). Hydrophobic N-terminal blocking groups (*N*-benzoyl and *N*-octanoyl) enhance peptide-binding affinity relative to an *N*-acetyl blocking group, whereas bulky N-terminal blocking groups (*N*-t-butoxycarbonyl or *N*-4-benzoyl-benzoyl) reduce peptide-binding affinity (Welply *et al.*, 1983; Xu T., Khanna H., *et al.*, 1998). Taken together with the effect of X-residue substitutions within an N-X-S sequon (Shakin-Eshleman *et al.*, 1996), these observations indicate that residues other than asparagine and the hydroxy amino acid (S or T) can facilitate acceptor-substrate binding to the OST active site.

Two strategies have been used to obtain high-affinity substrates and more potent OST inhibitors. Conformationally constrained peptides that adopt  $\beta$ -turn or asparagine-turn conformations have been tested as OST substrates, and it was found that peptides that adopt the latter, but not former, conformation are OST substrates (Imperiali *et al.*, 1992). Cyclization of synthetic OST substrates has been achieved by covalently linking an N-terminal blocking group on asparagine to the cysteine side chain in a N-C-T sequon to obtain the cyclo(hex-Asn-Cys)-Thr series of substrates or to an Amb-C-T tripeptide to obtain the cyclo(hex-Amb-Cys)-Thr series of OST inhibitors (Hendrickson *et al.*, 1996; Kellenberger *et al.*, 1997). Peptide cyclization appears to cause a relatively modest increase in the binding affinity relative to noncyclic-control peptides that have a hydrophobic, N-terminal blocking group (Kellenberger *et al.*, 1997; Peluso *et al.*, 2002). In contrast, a dramatic increase in the binding affinity ( $K_i < 50 \text{ nM}$ ) of OST inhibitors has been achieved by extending the C-terminus of the peptides by several residues to obtain cyclo(hex-Amb-Cys)-Thr-Val-Thr-Nph-NH<sub>2</sub>, where Nph corresponds to para-nitrophenylalanine (Hendrickson *et al.*, 1996). Peptide extensions that included one or more charged amino acids (e.g., K-K-Nph-NH<sub>2</sub>, E-K-Nph-NH<sub>2</sub>, or V-E-Nph-NH<sub>2</sub>) yielded markedly less-effective inhibitors or substrates (Kellenberger *et al.*, 1997). The design of the Val-Thr-Nph-NH<sub>2</sub> extension was based upon a careful reexamination (Imperiali and colleagues) of the statistical frequency of amino acids at the +3 and +4 residues adjacent to

utilized and nonutilized N-X-T sites (Gavel and Von Heijne, 1990).

### Context factors that influence N-linked glycosylation of sequons

It has been estimated that  $\sim 35\%$  of the potential glycosylation sites in proteins that enter the ER lumen are not modified (Petrescu *et al.*, 2004), and others are modified with low efficiency. Sequence analysis of a large collection of utilized and nonutilized N-X-T/S sites in proteins that enter the secretory pathway showed that a proline residue in the +3 site relative to asparagine reduces the statistical frequency of N-glycosylation (Gavel and Von Heijne, 1990). Hexapeptides with internal N-P-T sites or N-X-T-P sites are neither substrates nor low-affinity inhibitors (Bause, 1983). The statistical analysis of utilized N-glycosylation sites also supports the preference for N-X-T sites relative to N-X-S sites (Gavel and Von Heijne, 1990). The influence of amino acids in the X position of N-X-T and N-X-S sites has been tested in the context of the rabies virus glycoprotein. Although the identity of the X-residue had little effect upon the glycosylation efficiency of N-X-T sites, several residues (Glu, Asp, Trp, and Leu) significantly reduced the glycosylation efficiency of N-X-S sites (Shakin-Eshleman *et al.*, 1996). Analysis of several proteins with overlapping sequons (N-N-T/S-T/S) has shown that a single glycan is attached to such a site (Lockridge *et al.*, 1987; Reddy *et al.*, 1988, 1999). Recent results support the conclusion that an N-linked glycan at an asparagine residue reduces access of a closely spaced sequon to the OST active site (Karamyshev *et al.*, 2005).

Potential glycosylation sites that are located  $<12\text{--}14$  residues from a transmembrane (TM) span are not utilized by the vertebrate OST, indicating that the OST active site is  $\sim 30\text{--}40 \text{ \AA}$  above the luminal membrane surface of the RER (Nilsson and von Heijne, 1993). Not only does this distance restraint on glycosylation of membrane proximal N-X-T/S sites explain a lack of glycosylation of some integral membrane proteins, it is relevant to the glycosylation scanning mutagenesis procedure that has been used to elucidate the topology of membrane proteins (Hresko *et al.*, 1994). Sequons inserted into short luminal loops are not glycosylated (Popov *et al.*, 1997). Glycosylation sites near the C-terminus of proteins are also less likely to be utilized (Gavel and Von Heijne, 1990), presumably because chain termination allows the protein to move more rapidly past the OST active site. Glycosylation of N-X-T/S sites can also be reduced by a disulfide bond involving a nearby cysteine residue (Allen *et al.*, 1995) or delayed or inhibited if the N-X-T/S site is near the signal peptidase cleavage site (Chen *et al.*, 2001). Mutations that prevent folding of a glycoprotein may be accompanied by N-glycosylation at sequons that are not normally modified (McGinness and Morrison, 1994), indicating that rapid protein folding may be responsible for inefficient modification of some N-X-T/S sites. A detailed analysis of the extent of glycosylation at each of the 14 sites in yeast invertase suggests that additional sequence context factors may influence the efficiency of modification of individual glycosylation sites (Reddy *et al.*, 1988).

### Subunit composition of the OST in eukaryotic organisms

The OST has been most extensively investigated in the yeast (*Saccharomyces cerevisiae*) and vertebrate (canine pancreas) experimental systems. A combination of protein biochemistry and yeast molecular genetics experiments has led to the identification of eight polypeptides (Figure 2A) that are assembled into a heterooctameric yeast OST complex composed of one copy each of Ost1p, Ost2p, Ost3p or Ost6p, Ost4p, Ost5p, Wbp1p, Swp1p, and Stt3p (Karaoglu *et al.*, 1997; Spirig *et al.*, 1997). Although several papers describe yeast OST complexes that apparently lack 2–4 of the above subunits (Kelleher and Gilmore, 1994; Knauer and Lehle, 1994; Pathak and Imperiali, 1997), this discrepancy is explained by the difficulty in detecting the diffusely migrating Stt3 protein as well as the three low molecular weight subunits (Ost2p, Ost4p, and Ost5p) on sodium dodecyl sulfate (SDS)-polyacrylamide gels (Karaoglu *et al.*, 1997). Protein sequence database searches and protein purification results indicate that the yeast and vertebrate OST complexes have very similar subunit compositions (Kelleher and Gilmore, 1997; Kelleher *et al.*, 2003). Canine OST complexes composed of ribophorin I (Ost1p), ribophorin II (Swp1p), OST48 (Wbp1p), DAD1 (Ost2p), and an STT3 homologue have been purified from canine pancreas (Kelleher *et al.*, 2003). Below, the subunits of the OST are discussed in their approximate order of discovery.

#### Wbp1 (OST48)

The Wbp1 protein (OST48 in vertebrates) was the first identified subunit of the yeast OST (te Heesen *et al.*, 1992) and one of the first three identified subunits (ribophorin I, ribophorin II, and OST48) of the purified canine OST (Kelleher *et al.*, 1992; Silberstein *et al.*, 1992). Wbp1 (OST48) proteins have an N-terminal signal sequence that is cleaved in vivo (te Heesen *et al.*, 1991; Silberstein *et al.*, 1992), N-linked glycans (yeast Wbp1 but not canine OST48), a hydrophobic segment near the C-terminus that serves as a TM span, and a short cytoplasmic tail that has a C-terminal dilysine ER retention/retrieval motif (Gaynor *et al.*, 1994; Fu and Kreibich, 2000). These sequence features demonstrated that Wbp1 is a type I ( $N_{lum}C_{cyt}$ ) integral membrane protein with a large luminal domain (Figure 2A). Wbp1 proteins are encoded by genomes from diverse eukaryotes including vertebrates, fungi, nematodes, arthropods, plants, *Dictyostelium discoideum*, and many, but not all protists (Figure 2A–D), and show little variation in polypeptide length between organisms. Protein sequence comparisons suggest that Wbp1 proteins are members of the GldG/intraflagellar transport (GIFT) domain protein family that includes diverse prokaryotic and eukaryotic proteins (Beatson and Ponting, 2004). As the X-ray structure of a GIFT domain has not been solved, the biological function and structure of this domain in the Wbp1 proteins is not known.

Point mutations in Wbp1 reduce in vivo and in vitro OST activity (te Heesen *et al.*, 1992) and destabilize the OST complex (Karaoglu *et al.*, 1997). Deletion of the Wbp1 TM span or replacement of this segment with other hydrophobic sequences is not tolerated because of lack of incorporation of these mutant proteins into the OST complex (Li *et al.*, 2003). Two papers that predated the identification of STT3 as the active-site subunit suggested that Wbp1/OST48 provides the

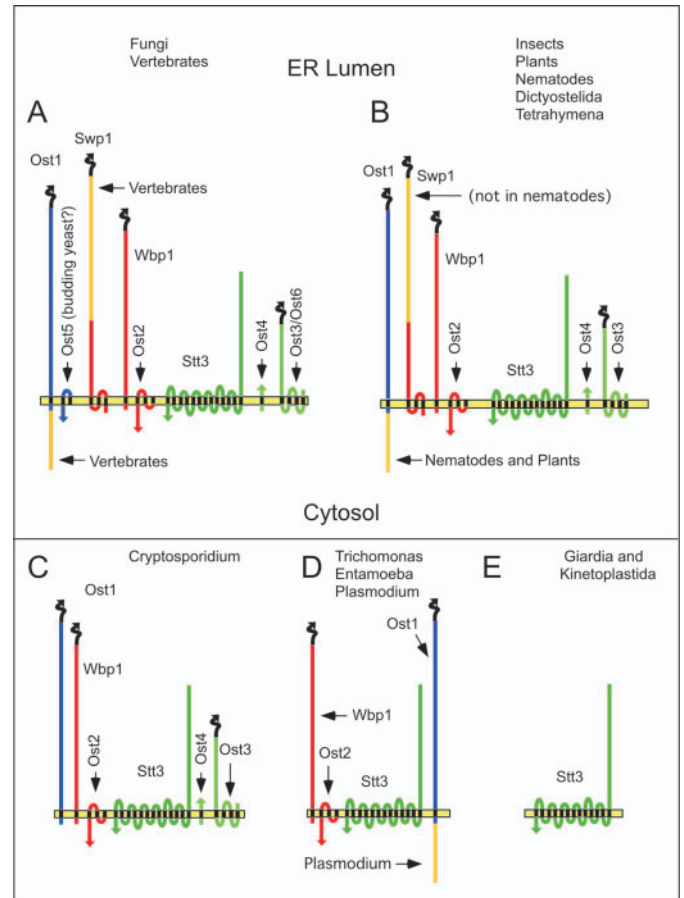

**Fig. 2.** The OST complex in diverse eukaryotes. The luminal side of the ER membrane is at the **top** of each panel. The experimentally verified or predicted topologies for each subunit are shown. A black curved arrow designates a cleaved N-terminal signal sequence; colored arrowheads designate the N-termini of proteins that lack cleaved signal sequences. The OST subunits are color coded to designate the three putative subcomplexes (blue for Ost1–Ost5, red for Swp1–Wbp1–Ost2, green for Stt3–Ost3–Ost4) and are drawn to scale. Yellow lines in panels A–D designate N-terminal (ribophorin II) or C-terminal (ribophorin I) extensions that are present/predicted as indicated by the labeled arrows. (A) The subunit composition of the fungal (*Saccharomyces cerevisiae*) and vertebrate (*Canis familiaris*) OST complexes are based upon biochemical and genetic evidence summarized in the text. Predicted subunit compositions for organisms other than *Saccharomyces cerevisiae* and *Canis familiaris* (A–E) are based upon protein and DNA sequence database searches using *Saccharomyces cerevisiae* and human OST sequences as the query sequence. (A) Predicted OST complexes for other fungi (*Schizosaccharomyces pombe*, *Cryptococcus neoformans*, and *Aspergillus nidulans*) and vertebrates (*Homo sapiens* and *Mus musculus*) have seven or eight subunits (see text). (B) Predicted OST complexes for insects (*Drosophila melanogaster* and *Anopheles gambiae*), plants (*Arabidopsis thaliana* and *Oryza sativa*), nematodes (*Caenorhabditis elegans*), *Dictyostelium discoideum*, and *Tetrahymena thermophila* have seven subunits. OST complexes from protists are predicted to have six subunits (C, *Cryptosporidium parvum*), four subunits (D, *Entamoeba histolytica*, *Trichomonas vaginalis*, and *Plasmodium falciparum*) or a single subunit (E, *Giardia lamblia*, *Trypanosoma cruzi*, and *Trypanosoma brucei*).

oligosaccharide donor and acceptor binding sites that are critical for enzyme activity. Covalent inactivation of the yeast OST with a sulfhydryl reagent can be blocked by the presence of Dol-PP-GlcNAc<sub>2</sub>, indicating that a cysteine residue, which was mapped to Wbp1, is located in the dolichol-oligosaccharide

binding site of the OST (Pathak *et al.*, 1995). The significance of this result cannot be discounted given that enzyme kinetic experiments now suggest that the OST has two independent OS-PP-Dol binding sites (Karaoglu *et al.*, 2001). OST48 and a 68-kDa protein (thought to be ribophorin I at the time, but probably STT3A instead) were labeled with a suicide substrate analogue, wherein the hydroxy amino acid (T or S) was replaced by epoxyethylglycine (Bause *et al.*, 1997).

#### *Ost1 (ribophorin I)*

The Ost1/ribophorin I subunit is present in the purified yeast and vertebrate OST complexes. The yeast *OST1* gene was isolated based upon peptide sequence data (Silberstein S., Collins P.G., Kelleher D.J., Rapiejko P.J., *et al.*, 1995) and identified in a genetic screen for mutations that reduce OST activity (Reiss *et al.*, 1997). The Ost1 proteins have an N-terminal signal sequence that is cleaved in vivo, N-X-T/S sites that carry N-linked glycans in yeast and vertebrates, a single TM span and a C-terminal cytosolic domain, hence Ost1 proteins have a type I (N<sub>lum</sub>-C<sub>cyt</sub>) topology (Crimaudo *et al.*, 1987; Silberstein S., Collins P.G., Kelleher D.J., Rapiejko P.J., *et al.*, 1995). Protein sequence database searches reveal that Ost1/ribophorin I orthologues are encoded by all fully sequenced eukaryotic genomes except *Encephalitozoon cuniculi*, *G. lamblia*, and the kinetoplastids (Figure 2A–D). The cytoplasmic domains of Ost1/ribophorin I proteins are either <10 residues in length (fungi, insects, and many protists) or 140–160 residues in length (vertebrates, plants, nematodes, and Plasmodium). Consensus protein secondary structure prediction algorithms (<http://npsa-pbil.ibcp.fr/>) indicate that the longer cytoplasmic tails have a high probability of being  $\alpha$ -helical.

Point mutations in Ost1 reduce N-linked glycosylation in vivo and reduce in vitro OST activity (Silberstein S., Collins P.G., Kelleher D.J., Rapiejko P.J., *et al.*, 1995). Labeling of Ost1 with photoreactive acceptor substrates was detected using an immunoprecipitation strategy (Yan *et al.*, 1999). However, subsequent studies did not support the initial conclusion that Ost1 was the active site subunit.

Ribophorins I and II are abundant proteins of the mammalian RER (Kreibich *et al.*, 1978) that are present in roughly equal amounts relative to membrane-bound ribosomes (Marcantonio *et al.*, 1984). Antibodies raised against the cytoplasmic domain of ribophorin I interfere with protein translocation across the RER by preventing ribosome targeting to the Sec61 complex (Yu *et al.*, 1990), thereby indicating that the OST is adjacent to the protein translocation channel. The location of OST adjacent to the translocon allows the cotranslational modification of the nascent polypeptide as it enters the lumen of the RER (Chen *et al.*, 1995).

#### *Swp1 (ribophorin II)*

The yeast *SWP1* gene was isolated as a high-copy suppressor of a *wbp1* mutant (te Heesen *et al.*, 1993), and Swp1 (ribophorin II) is present in the purified yeast and canine OST complexes. The Swp1 proteins have an N-terminal signal sequence that is cleaved in vivo, an N-glycosylation sequon that is modified in ribophorin II, and three hydrophobic segments located near the C-terminus (Rosenfeld *et al.*, 1984; Crimaudo *et al.*, 1987; te Heesen *et al.*, 1993; Kelleher and

Gilmore, 1994). Protease digestion experiments have shown that C-terminus of ribophorin II is insensitive to protease digestion in intact microsomes (Crimaudo *et al.*, 1987) consistent with a three TM (N<sub>lum</sub>-C<sub>cyt</sub>) topology depicted in Figure 2A. Swp1/ribophorin II proteins are only encoded by a subset of eukaryotic genomes (Figure 2A and B) suggesting that this subunit was a relatively late addition to the OST complex. Nematode and fungi genomes encode truncated forms of Swp1/ribophorin II that lack an N-terminal domain that is predicted to be  $\alpha$ -helical. RNAi of *Caenorhabditis elegans* ribophorin II causes an embryonic lethal phenotype (Fraser *et al.*, 2000) consistent with the previous demonstration that Swp1 is essential in yeast (te Heesen *et al.*, 1993).

#### *Ost2 (DAD1)*

Ost2 was initially detected as a 16-kD subunit in the purified yeast OST complex (Kelleher and Gilmore, 1994) and was subsequently shown to be present in the mammalian OST complex (Kelleher and Gilmore, 1997) using antibodies specific for the vertebrate homologue DAD1 (Nakashima *et al.*, 1993). Ost2 (DAD1) subunits are low molecular weight (112–130 residues) proteins that consist of a polar N-terminal segment of variable length, followed by three conserved hydrophobic segments. Protease accessibility experiments have shown that the N-terminus and the hydrophilic segment between TM2 and TM3 are exposed on the cytoplasmic face of the membrane (Silberstein S., Collins P.G., Kelleher D.J., and Gilmore R., 1995; Kelleher and Gilmore, 1997), consistent with the 3-TM (N<sub>cyt</sub>-C<sub>lum</sub>) topology model shown in Figure 2A. An alternative topology model for Ost2p that depicts a 3-TM span protein with an inverted topology (Yan *et al.*, 2003) is incompatible with the protease accessibility data cited above and is not in agreement with an Ost2p-reporter gene fusion experiment that suggests that the C-terminus is located within the RER lumen (Yan *et al.*, 2005). An alternative 2-TM (N<sub>cyt</sub>-C<sub>cyt</sub>) span model for DAD1 (Makishima *et al.*, 1997) is based upon the assumption that the third hydrophobic segment is too polar to be integrated into the membrane. We would argue that TM3 of Ost2/DAD1 contacts the TM spans of other OST subunits, rather than phospholipid when Ost2/DAD1 is assembled into the OST complex. Ost2/DAD1 proteins are encoded by all fully sequenced eukaryotic genomes except *E. cuniculi*, *G. lamblia*, and the kinetoplastids (Figure 2A–D).

Point mutations in the TM spans of Ost2 cause in vivo and in vitro reductions in OST activity at the restrictive temperature (Silberstein S., Collins P.G., Kelleher D.J., and Gilmore R., 1995). A temperature sensitive mutation in the hamster DAD1 (defender against death) protein causes an apoptotic phenotype in the tsBN7 cell line because of instability of DAD1 (Nakashima *et al.*, 1993). Degradation of DAD1 at the restrictive temperature results in a severe defect in OST activity (Makishima *et al.*, 1997; Sanjay *et al.*, 1998). The apoptotic phenotype of tsBN7 cells is most likely because of the irreversible induction of the unfolded protein response (UPR) pathway caused by the accumulation of unfolded glycoproteins, as tunicamycin can also induce apoptosis in plant and vertebrate cell lines (Pérez-Salva and Mollinedo, 1995; Walker *et al.*, 1998; Iwata and Koizumi, 2005).

## STT3

Mutations in the yeast *STT3* locus were isolated in a screen for yeast that showed enhanced sensitivity to staurosporine (Yoshida *et al.*, 1992), an inhibitor of protein kinase C. Additional *stt3* alleles were obtained in genetic screens for mutations that confer a synthetic lethality phenotype when combined with the *wbp1-2* allele (Zufferey *et al.*, 1995) or the *alg5Δ* allele (Reiss *et al.*, 1997). Because the yeast *STT3* gene encodes a 78-kDa protein that was not detected in the purified yeast OST complex (Kelleher and Gilmore, 1994; Knauer and Lehle, 1994; Pathak and Imperiali, 1997), it was initially unclear whether Stt3 was an OST subunit (Yoshida *et al.*, 1995; Zufferey *et al.*, 1995). Subsequent immunopurification experiments using yeast strains that express affinity-tagged OST subunits (STT3-HA, STT3-protein A, or OST3-HA) demonstrated that Stt3 is in an equimolar complex with the other OST subunits (Karaoglu *et al.*, 1997; Spirig *et al.*, 1997).

The topology of the Stt3 proteins is more difficult to predict and experimentally verify than any of the other OST subunits. Eukaryotic Stt3 proteins consist of an N-terminal hydrophobic domain composed of 12–13 predicted TM spans followed by a C-terminal hydrophilic domain that is located within the RER lumen (Zufferey *et al.*, 1995). The N-termini of canine STT3A and yeast Stt3 is exposed to the cytosol, hence eukaryotic STT3 proteins must have an uneven number of TM spans (e.g., 11 or 13) and a  $N_{\text{cyt}}C_{\text{lum}}$  topology (Kelleher *et al.*, 2003; Kim *et al.*, 2005). STT3 topology models with 13 TM spans (as depicted in Figure 2) are based on the assumption that each of the 13 hydrophobic segments are bona fide TM spans, whereas 11 TM span models necessitate that two of the hydrophobic segments are instead exposed on the cytosolic or luminal faces of the membrane. A comprehensive investigation of the topology of the yeast and mouse STT3 proteins provided support for two conflicting 11 TM span models (Kim *et al.*, 2005), suggesting that structural biology data will be needed to define the topology of the Stt3 proteins.

As initially suggested by the alignment of STT3 protein sequences from *S. cerevisiae*, *C. elegans*, and *Mus musculus* (Zufferey *et al.*, 1995), the Stt3 subunit is the most highly conserved polypeptide in the OST complex. With the exception of *E. cuniculi*, which lacks N-linked glycosylation, all fully sequenced eukaryotic genomes encode at least one member of the Stt3 protein family (Figures 2 and 3). Vertebrate, plant, and insect genomes encode two STT3 proteins that we have designated as STT3A and STT3B (Kelleher *et al.*, 2003). Vertebrate STT3A was initially named TM conserved (TMC) (Lissy *et al.*, 1996), whereas STT3B is also known as source of immunodominant major histocompatibility complex-associated peptides (SIMP) (McBride *et al.*, 2002). Phylogenetic tree analysis shows that STT3B proteins are more closely related to the fungal and nematode STT3 proteins, whereas the STT3A protein cluster includes STT3 from *D. discoideum* (Figure 3). Several protist genomes encode multiple STT3 proteins that reflect gene duplication events that are unrelated to the derivation of the STT3A and STT3B subfamilies. For example, four consecutive genes on one chromosome encode the predicted *Leishmania major* STT3 proteins. To our knowledge, it is not known whether multiple STT3 proteins are simultaneously expressed in protist organisms.

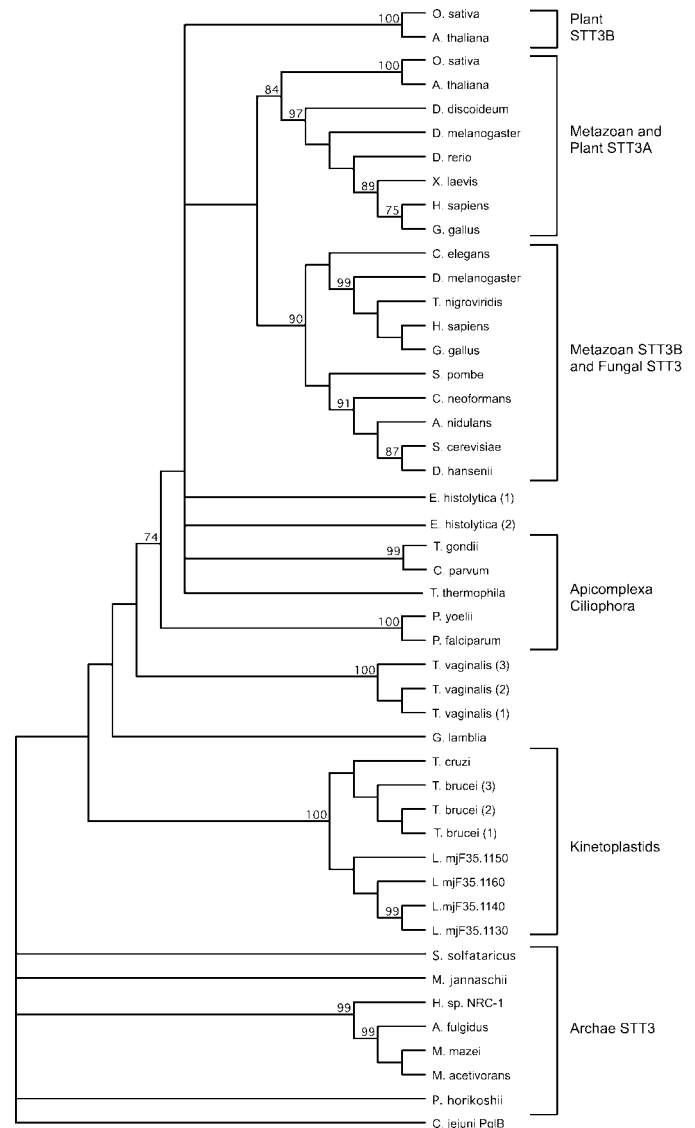

**Fig. 3.** Phylogenetic tree analysis of STT3 proteins. STT3 protein sequences were obtained by protein and DNA sequence database searches (Kelleher *et al.*, 2003; Samuelson *et al.*, 2005) using the *Saccharomyces cerevisiae* Stt3 and human STT3A as query sequences. Representative fungal and metazoan STT3 sequences as well as all currently available protist sequences were selected for alignment. Several archaeobacterial and eubacterial STT3 homologues were used to root the phylogenetic tree.

*Ost3/Ost6 (N33 and IAP)*

The Ost3 protein was initially detected as a 34-kD subunit in the yeast OST complex (Kelleher and Gilmore, 1994). Ost6p is a homologue of Ost3p that is assembled into a second, less abundant, form of the yeast OST complex that lacks Ost3p as a subunit (Karaoglu *et al.*, 1997; Knauer and Lehle, 1999; Spirig *et al.*, 2005). The Ost3 family of proteins have an N-terminal signal sequence that is cleaved in vivo in yeast, a 160–180 residue N-terminal luminal domain that includes one thioredoxin repeat (Fetrow *et al.*, 2001) followed by four predicted TM spans (Karaoglu *et al.*, 1995). Consequently, the Ost3 proteins are integrated into the RER



with a 4-TM ( $N_{lum}$ - $C_{lum}$ ) topology (Figure 2A). Recently, the 4-TM ( $N_{lum}$ - $C_{lum}$ ) topology for the Ost3 family has been disputed based upon results obtained with a reporter-gene fusion strategy (Yan *et al.*, 2003, 2005). An alternative topology model for Ost3 predicts that a very short, weakly hydrophobic segment within the thioredoxin motif of Ost3p functions as a fifth TM span, thereby inverting the topology of Ost3 to yield a 5-TM ( $N_{lum}$ - $C_{cyt}$ ) topology (Yan *et al.*, 2003, 2005). Both termini of Ost6 are proposed to face the cytosol in a 4-TM ( $N_{cyt}$ - $C_{cyt}$ ) topology (Yan *et al.*, 2005), which would expose the N-terminal signal sequence and the thioredoxin domain of Ost6 on to the cytoplasmic side of the membrane (Chavan *et al.*, 2005). How can we explain the discrepancy between these recent proposals and the previously accepted topology model shown in Figure 2A? Although reporter-domain fusions have been used extensively to define the topology of bacterial and vertebrate membrane proteins, this strategy can be less satisfactory in yeast (as discussed by Kim H., Melen K., *et al.*, 2003), because integration of membrane proteins can be perturbed by an N-terminal fusion joint that inactivates a signal sequence or by a C-terminal fusion joint that interferes with integration of the final TM span (Green and Walter, 1992).

Protein sequence database searches show that members of the Ost3 family of proteins are encoded by all fully sequenced vertebrate, nematode, fungi (except *E. cuciculi*), arthropod, and plant genomes. In addition, Ost3 homologues are encoded by *D. discoideum*, *Tetrahymena thermophila*, and *Cryptosporidium parvum*. The gene duplication event that is responsible for the *OST6* gene is restricted to the *Saccharomycetaceae* family of budding yeasts. Phylogenetic tree analysis using currently available fungal Ost3/Ost6 sequences indicates that other fungal genomes encode a protein that is more closely related to Ost3 than to Ost6p (not shown). Vertebrate genomes encode two closely related Ost3 homologues that are annotated as N33 and IAP (MacGrogan *et al.*, 1996; Kelleher *et al.*, 2003). Unlike Ost3 and Ost6 that are present in the purified yeast OST complex (Kelleher and Gilmore, 1994; Karaoglu *et al.*, 1997) and comigrate with the OST on Blue-Native gels (Knauer and Lehle, 1999), N33 and IAP appear to be loosely associated with the canine OST complex and dissociate at various stages during enzyme

purification (Kelleher *et al.*, 2003) or during Blue-Native polyacrylamide gel electrophoresis (Shibatani *et al.*, 2005).

Disruption of the yeast *OST3* or *OST6* genes does not cause a growth defect at any temperature in an otherwise wild-type strain (Karaoglu *et al.*, 1995; Knauer and Lehle, 1999). Loss of Ost3p expression in yeast causes a modest, and substrate dependent, reduction in the *in vivo* glycosylation of proteins (Karaoglu *et al.*, 1995). The mild phenotypes of the *ost3Δ* strain are explained in part by redundancy, as an *ost3Δost6Δ* strain has a more severe defect in glycosylation than either single mutant (Knauer and Lehle, 1999; Spirig *et al.*, 2005). The *C. elegans* *OST3* gene (ZK686.3) is essential; RNAi of ZK686.3 causes an embryonic lethal phenotype (Kamath *et al.*, 2003) because of a defect in cytokinesis (Gonczy *et al.*, 2000).

#### Ost4p

The yeast *OST4* gene was identified in a screen for yeast mutants that are resistant to sodium vanadate and sensitive to hygromycin B (Chi *et al.*, 1996), two properties that are shared by many yeast mutants that impact different steps in cell-wall biosynthesis (Dean, 1995). Point mutations, or the complete deletion, of the nonessential yeast *OST4* gene causes severe *in vivo* hypoglycosylation of glycoproteins and a temperature sensitive growth defect (Chi *et al.*, 1996). Remarkably, the *OST4* gene encodes a 36-residue polypeptide (Chi *et al.*, 1996), which is one of the smallest verified proteins encoded by the yeast genome. The single TM span in Ost4p is preceded by acidic residues and followed by basic residues thus favoring integration in the type I ( $N_{lum}$ - $C_{cyt}$ ) topology as initially proposed (Karaoglu *et al.*, 1997; Spirig *et al.*, 1997). Although a type I topology for Ost4p has been disputed (Kim *et al.*, 2000), a more recent study confirmed the original prediction (Kim H., Yan Q., *et al.*, 2003).

Homologues of yeast Ost4 are encoded by fungi, vertebrate, nematode, insect, plant, and several protist genomes (Figure 2A–C). Relatively few of these OST4 sequences are currently annotated in protein sequence databases. For example, the human and mouse expressed sequence tags (EST) databases contain highly expressed mRNAs that encode the 37-residue Ost4 homologue shown in Figure 4.

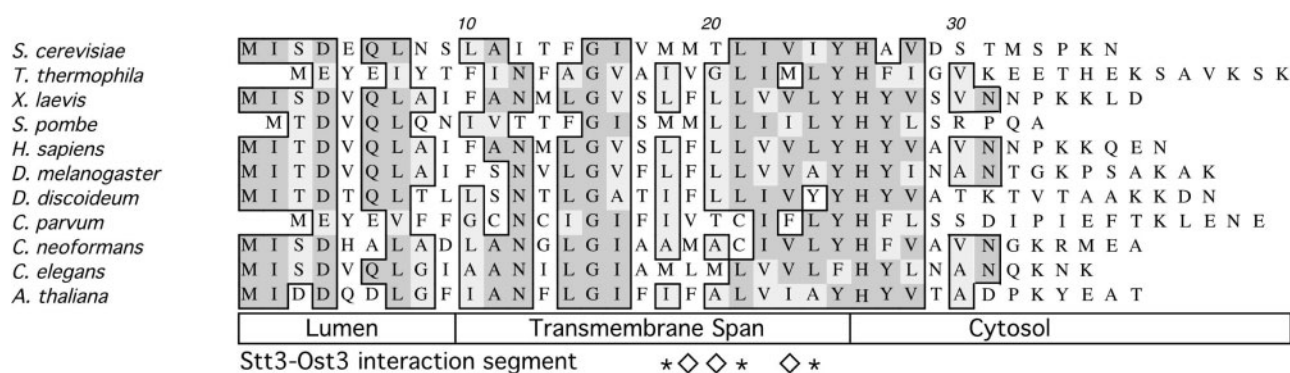

**Fig. 4.** Alignment of eukaryotic OST4 sequences. OST4 sequences were obtained by protein and DNA sequence database searches using *Saccharomyces cerevisiae* Ost4 as the query sequence. Representative fungal and metazoan OST4 sequences as well as all currently available protist sequences were selected for alignment using ClustalW. Regions of homology are boxed, with amino acid identities designated by dark shading. Replacement of hydrophobic residues (M18 to I24) in the TM span of *Saccharomyces cerevisiae* Ost4 with lysine or aspartic acid caused temperature sensitive growth defects and destabilized the interaction between Stt3 and Ost4 (asterisks) or destabilized the interaction between Ost4 and Ost3 (asterisks and diamonds) (Kim *et al.*, 2000).

Ost4 proteins consist of conserved luminal and TM segments followed by a poorly conserved cytoplasmic domain of variable length (Figure 4). Mass spectroscopy of the purified canine OST complex has shown that a protein with a mass (4193 Da) consistent with the vertebrate Ost4 sequence is present in the complex (Kelleher and Gilmore, unpublished data). Hence we are confident that Ost4 is an OST subunit in diverse eukaryotes (Figure 2A–C).

#### Ost5

Ost5 was initially detected as a 9-kDa subunit in the yeast OST complex (Kelleher and Gilmore, 1994). The *OST5* gene was identified in a screen for yeast genes that encode OST subunits (Reiss *et al.*, 1997). Deletion of the yeast *OST5* gene causes a minor defect in the *in vivo* glycosylation of yeast proteins and a reduction in OST activity that is not caused by an altered affinity for donor or acceptor substrates (Reiss *et al.*, 1997). Ost5p is an 86-residue protein with two-predicted TM spans. The 2-TM N<sub>cyt</sub>-C<sub>cyt</sub> topology that was predicted for Ost5p (Reiss *et al.*, 1997) has been confirmed (Yan *et al.*, 2005). Although putative Ost5 homologues can be identified in metazoan organisms using protein sequence database searches (Kelleher and Gilmore, unpublished results), biochemical evidence that these polypeptides are OST subunits has not been obtained (Kelleher *et al.*, 2003; Shibatani *et al.*, 2005).

#### The STT3 subunit contains the catalytic site of the OST

The five OST subunits (Stt3, Ost1, Ost2, Swp1, and Wbp1) that are encoded by essential yeast genes were the logical candidates for the active-site subunit of the OST. Of these five proteins, only the Stt3 protein has archaeobacterial homologues (Spirig *et al.*, 1997). Alignment of eukaryotic and archaeobacterial STT3 proteins resulted in the identification of a short invariant sequence (WWDYG motif) that is present in all members of the STT3 family (Spirig *et al.*, 1997; Burda and Aebi, 1999). During the past several years, overwhelming evidence has been obtained indicating that Stt3 family proteins catalyze N-linked glycosylation in eukaryotes, archaeobacteria and in selected eubacteria.

The most direct evidence that Stt3 proteins are the catalytic subunits of the eukaryotic OST was provided by an elegant *in vivo* analysis of the *C. jejuni* *pgl* operon. N-linked glycosylation of AcrA, a *C. jejuni* membrane protein was dependent upon a wild-type PglB locus (Wacker *et al.*, 2002). Moreover, the expression of AcrA and the complete *pgl* operon in *Escherichia coli* reconstituted N-linked glycosylation activity in the *E. coli* host unless point mutations were introduced into the WWDYG motif in PglB (Wacker *et al.*, 2002). Genetic analysis of PglB has been facilitated by the nonessential nature of N-linked glycosylation in *C. jejuni* and in the *E. coli* host system. Structural analysis of the resulting glycopeptide showed that the modified asparagine (N\*) was present within the peptide DFN\*VSK (Wacker *et al.*, 2002), where the underlined sequence matches the N-X-T/S sequon for eukaryotic N-linked glycopeptides. The N-X-T/S sequence is necessary, but not sufficient for N-linked glycosylation in *C. jejuni*, as several

N-X-T/S sites in the AcrA and HisJ glycoproteins are not modified (Nita-Lazar *et al.*, 2005). However, because 35% of N-X-T/S sequons are not modified by the eukaryotic OST, further work will be required to define a minimum consensus site for PglB. The heptasaccharide (GalNAc- $\alpha$ 1,4-GalNAc- $\alpha$ 1,4-(Glc $\beta$ 1,3)-GalNAc- $\alpha$ 1,4-GalNAc- $\alpha$ 1,4-GalNAc- $\alpha$ 1,3-Bac) transferred to proteins by the *C. jejuni* PglB protein bears little resemblance to the high-mannose oligosaccharide donor assembled by eukaryotic cells (Young *et al.*, 2002), except that the saccharide linked to the undecaprenyl-pyrophosphate carrier is an amino sugar (i.e., Bac = bacillosamine = 2,4,diacetamido-2,4,6-trideoxyglucose). The relaxed donor-substrate specificity for the eubacterial OST was further demonstrated by the discovery that structurally diverse oligosaccharides attached to undecaprenyl pyrophosphate are utilized when PglB is expressed in *E. coli* (Feldman *et al.*, 2005).

Evidence that Stt3 contains the catalytic center of the yeast OST has been provided by a combination of photolabeling experiments and site-directed mutagenesis (Yan and Lennarz, 2002b). Three of the OST subunits (Ost1, Ost3, and Stt3) can be photolabeled with acceptor peptides that incorporate a photoreactive benzophenone side chain near an N-X-T glycosylation site. Mutagenesis of the C-terminal luminal domain of yeast Stt3 yielded a collection of assembly defective and assembly competent *stt3* mutants that displayed severe growth defects and dramatically reduced OST activity. Point mutations in the WWDYG motif of yeast Stt3p eliminate or dramatically reduce OST activity (Yan and Lennarz, 2002b).

Highly selective photocross-linking of a nascent polypeptide to the active site of the canine STT3A has been achieved by incorporating a photoreactive derivative of lysine (K\*) adjacent to a cryptic glycosylation site (Q-K\*-T instead of N-K\*-T) in a nascent chain undergoing translocation into the RER lumen (Nilsson *et al.*, 2003). Unlike the photolabeling experiments summarized above (Yan and Lennarz, 2002b), cross-links between other OST subunits and the cryptic glycosylation site were not detected. Photocross-linking of the cryptic glycosylation site to STT3A occurred when the photoprobe was located at least 69 residues away from the peptidyl-transferase site on the ribosome (Nilsson *et al.*, 2003), which correlates well with the minimal length between the peptidyl-transferase site and an N-X-T/S that can be glycosylated in a ribosome-bound nascent polypeptide (Whitley *et al.*, 1996). These results reinforce the conclusion that the N-X-T/S sites pass by the OST active site as the nascent polypeptide emerges from the luminal face of the protein translocation channel.

Biochemical evidence that STT3 proteins are the active site subunits of the OST complex was provided by the kinetic analysis of canine OST complexes that incorporate different isoforms of the STT3 subunit (Kelleher *et al.*, 2003). OST complexes that have an STT3A subunit display a higher specificity for selecting the fully assembled dolichol-linked oligosaccharide donor (Glc<sub>3</sub>Man<sub>9</sub>GlcNAc<sub>2</sub>-PP-Dol) than OST complexes that contain an STT3B subunit. These differences in donor-substrate selection are explained by STT3 isoform-dependent differences in the kinetic parameters of the OST active site (Kelleher *et al.*, 2003).

### Organization of subunits into the OST complex

Biochemical and genetic evidence for specific protein–protein interactions between the OST subunits has steadily accumulated during the past decade. In the absence of a high-resolution OST structure, we consider how these results can be incorporated into a working model for the eukaryotic OST complex.

#### *Nearest-neighbor analysis suggest OST subcomplexes*

The first evidence for interactions between OST subunits was provided by the isolation of the *SWP1* gene as an allele-specific high-copy suppressor of the *wbp1-2* mutant (te Heesen *et al.*, 1993). The overexpression of Ost2, like Swp1, suppresses the temperature sensitive growth defect of a *wbp1-2* strain by stabilizing Wbp1 (Silberstein S., Collins P.G., Kelleher D.J., and Gilmore R., 1995). Reciprocal gene product depletion experiments (Knauer and Lehle, 1994), protein cross-linking studies (te Heesen *et al.*, 1993), and yeast two-hybrid experiments (Fu *et al.*, 1997) indicate that Swp1 (ribophorin II) interacts directly with and, by so doing, stabilizes Wbp1 (OST48). Chemical cross-linking experiments have defined direct interactions between DAD1, OST48, and ribophorin II (Kelleher and Gilmore, 1997). Ost48 and ribophorin II are unstable when tsBN7 cells (DAD1-ts cell line) are shifted to the restrictive temperature (Sanjay *et al.*, 1998). Reciprocal loss of stability would be a weak argument for protein interactions between Wbp1, Swp1, and Ost2, if a given mutation (e.g., *wbp1-2*) reduced the stability of all eight OST subunits. However this does not appear to be the case based upon western blot analysis of OST subunit content in *wbp1-2* and *ost2-3* mutants (Silberstein S., Collins P.G., Kelleher D.J., and Gilmore R., 1995; Karaoglu *et al.*, 1997). These results led to the proposal that Wbp1, Swp1, and Ost2 are adjacent in the OST and constitute one of three subcomplexes (Karaoglu *et al.*, 1997; Spirig *et al.*, 1997).

Several lines of evidence indicate that Ost3 and Ost4 interact directly with Stt3 in a second subcomplex (Figure 2A). The *OST3* and *OST4* genes are high-copy allele specific suppressors of several *stt3* mutants, and *OST3* is a high-copy suppressor of the temperature sensitive growth defect of the *ost4Δ* mutant (Spirig *et al.*, 1997). Biochemical support for these interactions was provided by the observation that an Stt3–Ost3–Ost4 heterotrimer is recovered when an immunopurified OST complex is incubated in a mixed-detergent micelle (Triton X-100-SDS) wash buffer (Karaoglu *et al.*, 1997). Coimmunoprecipitation experiments have shown that Ost3p dissociates from the OST complex in detergent extracts prepared from an *ost4Δ* mutant, indicating that Ost4 stabilizes the association between Ost3 and Stt3 (Karaoglu *et al.*, 1997). Point mutations that introduce charged amino acid residues into the C-terminal half of the Ost4 TM span (Kim *et al.*, 2000; Kim H., Yan Q., *et al.*, 2003) cause severe growth defects and destabilize interactions between Stt3, Ost3, and Ost4 (Figure 4). The dissociation of N33 and IAP from canine OST complexes (Kelleher *et al.*, 2003) and the dissociation of Ost3 in an *ost4Δ* mutant (Karaoglu *et al.*, 1997; Kim *et al.*, 2000) is best explained by a peripheral location for the OST3 proteins in vertebrate and fungal complexes. Notably, disruption of the yeast

*OST3* gene does not destabilize the remaining subunits in the OST complex (Karaoglu *et al.*, 1997).

Genetic evidence for a third subcomplex (Ost1–Ost5) was provided by the discovery that the *OST5* gene is a high-copy suppressor of the *ost1-5* allele (Reiss *et al.*, 1997). More recently, chemical cross-linking experiments provide additional support for the Ost1p–Ost5p interaction (Yan *et al.*, 2003). The protein–protein interactions summarized above must be a subset of those that exist within the OST, as the active enzyme does not readily dissociate into three stable subcomplexes when exposed to nonionic detergents. Although recent chemical cross-linking experiments suggest numerous additional subunit–subunit contacts (Yan *et al.*, 2003), it should be noted that the analytical methods used were unable to distinguish between a direct cross-link between two subunits and an indirect link that is mediated by an additional subunit.

#### *Assembly of subcomplexes into the OST; what do we learn from genomics?*

We can now consider the OST subcomplex hypothesis in light of the predicted diversity of eukaryotic OST complexes. With the exception of the 1-subunit enzymes predicted for organisms that are at the base of the eukaryotic phylogenetic tree (Figure 2E), the simplest eukaryotic OST is predicted to have four subunits (Figure 2D), including one or more subunits from each of the putative subcomplexes. We can infer from this information that Stt3 provides an interaction surface for the Wbp1–Ost2–Swp1 subcomplex that is not dependent upon Swp1 (Figure 2C and D). A direct interaction between Ost1 and Stt3, but not between Ost1 and the Wbp1–Ost2–Swp1 subcomplex, is suggested by the dissociation of Ost1 from the latter subcomplex in Stt3 depleted yeast cells (Zufferey *et al.*, 1995). These considerations suggest that STT3 provides independent binding sites for Ost1 and the Wbp1–Ost2 heterodimer (Figure 2D).

Three of the OST subunits (Ost2, Ost4, and Ost5) are hydrophobic miniproteins. It is noteworthy that an Ost4 protein is encoded by all fully sequenced genomes that encode an Ost3 protein (Figures 2A–C and 4). This observation supports the hypothesis that Ost4p is an assembly/stabilizing factor for the incorporation of an Ost3 family protein into the complex (Karaoglu *et al.*, 1997; Kim *et al.*, 2000). The topology and extensive conservation of the TM spans of Ost2 suggest the following: (i) the essential function of Ost2 can be mapped to the TM spans in accord with mutagenesis results (Silberstein S., Collins P.G., Kelleher D.J., and Gilmore R., 1995) and (ii) Ost2 may stabilize/mediate an interaction between Stt3 and Wbp1. Likewise, one can speculate that Ost5 stabilizes the interaction between Ost1 and Stt3.

Taken together, the genomic evidence indicates that the three OST subcomplexes are explained, at least in part, by the stepwise addition of subunits to an STT3 catalytic core during evolution of the eukaryotic OST. The first proteins to be added may have been an Ost1 monomer and the Wbp1–Ost2 heterodimer. Subsequent enlargement of the OST involved the addition of four peripheral subunits that were likely added as a heterodimer (Ost3–Ost4) and two

monomers (Swp1 and Ost5), with the Wbp1-Ost2 heterodimer contributing the binding site for Swp1. Although a recently published interaction map for the yeast enzyme places Ost1 in the center surrounded by other subunits (Yan *et al.*, 2005), such a location is incompatible with protein cross-linking results obtained using the mammalian experimental system (Kelleher and Gilmore, 1997) and yeast two hybrid experiments that did not detect interactions between ribophorin I and II (Fu *et al.*, 1997). Recently, it has been shown that ribophorin I can be cross-linked to a subset of nascent integral membrane proteins, in a sequon-independent manner, as the nascent chains exit the lateral gate of the Sec61 complex, suggesting an exposed location for Ost1/ribophorin I in the OST complex (Wilson *et al.*, 2005). Clearly, a better understanding of the protein-protein interactions within the OST complex will only be obtained when mid- or high-resolution structures of the OST complex are solved.

#### *OST isoforms in mammalian cells*

STT3A and STT3B are assembled into alternative forms of the canine OST complex that differ with respect to donor-substrate selection and specific activity (Kelleher *et al.*, 2003). Human multiple-tissue northern blots have shown that both the STT3A and the STT3B mRNAs are widely expressed in human tissues, and this conclusion is supported by the human UniGene database. Protein immunoblot experiments have shown that both STT3 isoforms are expressed in human fibroblasts and tissue culture cells (CH12.LX, HEK293, and HeLa cells; Kelleher *et al.*, 2003; Ruiz-Canada and Gilmore, unpublished data). Nonetheless, tissue-specific differences in the relative expression of the STT3 isoforms are readily apparent and may indicate that the enzymatic properties of the OST are regulated to respond to glycoprotein flux through the secretory pathway.

#### **Donor-substrate selection by the eukaryotic OST**

The terminal glucose residue on the dolichol-linked oligosaccharide strongly influences the rate of oligosaccharide transfer in vertebrate and fungal organisms (Turco *et al.*, 1977; Trimble *et al.*, 1980). The accumulation of nonoptimal OS-PP-Dol assembly intermediates is responsible for the reduced rate of oligosaccharide transfer to nascent glycoproteins in tissues from CDG-I patients. The utilization of a lumenally exposed assembly intermediate (Man<sub>5</sub>GlcNAc<sub>2</sub>-PP-Dol to Glc<sub>2</sub>Man<sub>9</sub>GlcNAc<sub>2</sub>-PP-Dol) should have a deleterious effect upon higher eukaryotic organisms, because the structure of a protein-bound oligosaccharide has a profound effect upon the ability of a nascent glycoprotein to fold correctly and be packaged into vesicles for intracellular transport or instead to be targeted for ER-associated degradation (ERAD) if folding is not successful (for a review, see Parodi, 2000; Schrag *et al.*, 2003; Helenius and Aebi, 2004).

The mechanism of oligosaccharide-donor selection has been investigated for more than two decades using enzyme kinetics methods (Trimble *et al.*, 1980; Breuer and Bause, 1995; Gibbs and Coward, 1999). The OST catalyzes a bisubstrate reaction, where both the donor and acceptor substrates must be present at the same time. The dolichol

pyrophosphate and glycopeptide products are not OST inhibitors (Gibbs and Coward, 1999; Peluso *et al.*, 2002). Competition experiments using donor substrate mixtures have shown that the fully assembled donor (Glc<sub>3</sub>Man<sub>9</sub>GlcNAc<sub>2</sub>-PP-Dol) is transferred 5–20 times faster than an assembly intermediate (e.g., Man<sub>9</sub>GlcNAc<sub>2</sub>-PP-Dol) when the OST is assayed using microsomal membranes (Karaoglu *et al.*, 2001) or a detergent-solubilized enzyme (Trimble *et al.*, 1980). Contrary to expectations, several early studies using detergent-solubilized OST showed that the apparent  $K_m$  for the donor oligosaccharide was not significantly influenced by the terminal glucose residues (Trimble *et al.*, 1980; Sharma *et al.*, 1981). Although the structure of the oligosaccharide donor does have an effect upon the apparent  $K_m$  for the acceptor substrate (Breuer and Bause, 1995; Gibbs and Coward, 1999), the relatively modest enhancement in peptide-binding affinity that is observed in the presence of Glc<sub>3</sub>Man<sub>9</sub>GlcNAc<sub>2</sub>-PP-Dol relative to that observed with an assembly intermediate cannot by itself explain the efficiency of donor-substrate selection.

Enzyme kinetic experiments using purified yeast (Karaoglu *et al.*, 2001) or canine (Kelleher *et al.*, 2003) OST and purified OS-PP-Dols of defined composition have now revealed unexpected properties of the OST complex. In agreement with previous studies (Welply *et al.*, 1983; Breuer and Bause, 1995; Hendrickson and Imperiali, 1995; Gibbs and Coward, 1999), acceptor-substrate saturation experiments yield linear Lineweaver-Burk plots consistent with a single binding site for the acceptor-peptide substrate (Karaoglu *et al.*, 2001; Kelleher *et al.*, 2003). In the case of the yeast OST, the apparent  $K_m$  for the acceptor substrate is enhanced by ~1.5-fold when Glc<sub>3</sub>Man<sub>9</sub>GlcNAc<sub>2</sub>-PP-Dol is the donor substrate relative to an assembly intermediate (Karaoglu *et al.*, 2001). Donor-substrate saturation curves for Glc<sub>3</sub>Man<sub>9</sub>GlcNAc<sub>2</sub>-PP-Dol were observed to be sigmoidal, not hyperbolic, and indicate that the yeast OST binds the donor substrate in a cooperative manner (Karaoglu *et al.*, 2001). Importantly, donor-substrate saturation curves obtained with an assembly intermediate (Man<sub>9</sub>GlcNAc<sub>2</sub>-PP-Dol) are also sigmoidal, indicating that a two-part binding site that recognizes both the terminal glucose residue and the dolichol-PP-GlcNAc<sub>2</sub> moiety cannot account for the cooperative-binding kinetics of the donor substrate. Two donor-substrate binding sites and one acceptor substrate binding site are compatible with a substrate activation model for the OST, wherein binding of the donor substrate to a regulatory OS-PP-Dol binding site is a prerequisite for binding of both the acceptor substrate and a second donor substrate to the catalytic site. The kinetic analysis of canine OST isoforms confirmed that higher eukaryotic OST complexes have two independent binding sites for the donor oligosaccharide and further showed that the identity of the catalytic subunit (STT3A versus STT3B) affected the active site kinetic parameters, but not the regulatory site kinetic parameter (Kelleher *et al.*, 2003).

How can a donor-substrate activation model for the OST explain the selective utilization of the fully assembled OS-PP-Dol? According to the substrate-activation model we have proposed (Figure 5), the ability of the OST to discriminate between the glucosylated and nonglucosylated donor substrates is determined by the ratio of two pairs of interaction

## Donor Substrate Selection

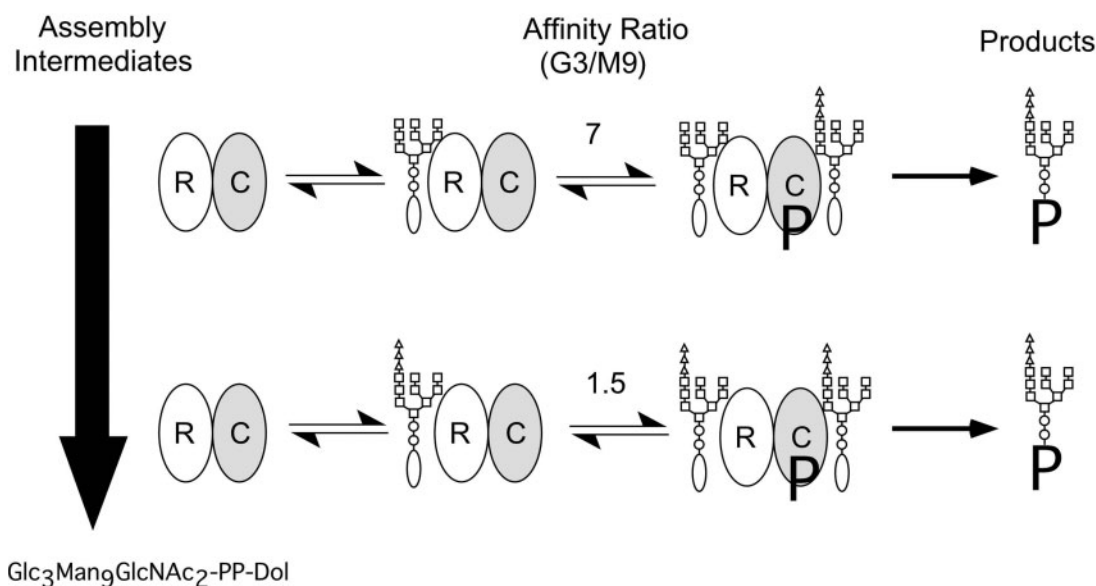

**Fig. 5.** A model for donor-substrate selection by the *Saccharomyces cerevisiae* OST. The OST is proposed to have two OS-PP-Dol binding sites: a regulatory (R) site and a catalytic (S) site. The location of the regulatory site is not known; Stt3 contains the catalytic site. Binding of OS-PP-Dol to the regulatory site activates the catalytic site for binding of OS-PP-Dol and the acceptor tripeptide (P). The affinity ratio (G3/M9) is the ratio of the interaction factors described in the text. The model depicts how Glc<sub>3</sub>Man<sub>9</sub>GlcNAc<sub>2</sub>-PP-Dol will be preferentially utilized even when an assembly intermediates (e.g., Man<sub>9</sub>GlcNAc<sub>2</sub>-PP-Dol) is more abundant.

factors ( $\gamma/\alpha$  and  $\delta/\beta$ ). The interaction factors describe how the structure of the OS-PP-Dol molecule bound to the regulatory site influences the binding affinity of the catalytic site for Glc<sub>3</sub>Man<sub>9</sub>GlcNAc<sub>2</sub>-PP-Dol or an assembly intermediate. Effectively, the substrate-activation mechanism allows the OS-PP-Dol-binding affinity of the catalytic site to be fine-tuned to favor the utilization of Glc<sub>3</sub>Man<sub>9</sub>GlcNAc<sub>2</sub>-PP-Dol when a mixed population of oligosaccharide donors is present. Because the affinity of the regulatory site for Glc<sub>3</sub>Man<sub>9</sub>GlcNAc<sub>2</sub>-PP-Dol and Man<sub>9</sub>GlcNAc<sub>2</sub>-PP-Dol is similar (94 and 67 nM, respectively), occupation of the regulatory site will reflect the composition of the donor oligosaccharide pool, which under normal physiological conditions will be enriched in Glc<sub>3</sub>Man<sub>9</sub>GlcNAc<sub>2</sub>-PP-Dol. When the regulatory site is occupied by Glc<sub>3</sub>Man<sub>9</sub>GlcNAc<sub>2</sub>-PP-Dol, the relative affinity of the catalytic site for the donor substrate will favor binding of the fully assembled donor by ~1.5-fold ( $\gamma/\alpha$ ) relative to an assembly intermediate. Consequently, the OST will primarily utilize Glc<sub>3</sub>Man<sub>9</sub>GlcNAc<sub>2</sub>-PP-Dol in vivo both because this compound is the most abundant donor and because of the homotropic interactions favoring Glc<sub>3</sub>Man<sub>9</sub>GlcNAc<sub>2</sub>-PP-Dol binding to the catalytic site. When the regulatory site is occupied by an assembly intermediate (e.g., Man<sub>9</sub>GlcNAc<sub>2</sub>-PP-Dol), the enzyme will display a 7- to 10-fold preference ( $\delta/\beta$ ) for Glc<sub>3</sub>Man<sub>9</sub>GlcNAc<sub>2</sub>-PP-Dol relative to an assembly intermediate, hence any available Glc<sub>3</sub>Man<sub>9</sub>GlcNAc<sub>2</sub>-PP-Dol will be preferentially utilized. What in vivo evidence supports this kinetic model for donor-substrate selection? The original yeast *alg3* mutant, which is slightly leaky,

preferentially utilizes the residual Glc<sub>3</sub>Man<sub>9</sub>GlcNAc<sub>2</sub>-PP-Dol to glycosylate proteins in vivo (Verostek *et al.*, 1993). The latter situation also occurs in wild-type yeast cells as the dextrose in growth media is depleted during late log phase (Trimble *et al.*, 1980) or in human CDG fibroblast cell lines that have leaky mutations in human *ALG* genes (Korner *et al.*, 1999). The complete absence of Glc<sub>3</sub>Man<sub>9</sub>GlcNAc<sub>2</sub>-PP-Dol from the donor oligosaccharide pool, as occurs in *alg* gene null mutants (e.g., *alg6Δ*; Reiss *et al.*, 1996), causes a reduction in the in vivo glycosylation of glycoproteins in accord with the reduced transfer rate predicted by the kinetic model. For a more detailed presentation of this model for donor-substrate selection by the eukaryotic OST, we refer the interested reader to Karaoglu *et al.* (2001).

Trypanosomes (de la Canal and Parodi, 1987) and many other protists (Samuelson *et al.*, 2005) assemble OS-PP-Dols that lack glucose residues, hence these organisms provide useful experimental systems to analyze donor-substrate selection by the OST. Unlike the yeast and mammalian OST which select Glc<sub>3</sub>Man<sub>9</sub>GlcNAc<sub>2</sub>-PP-Dol from a complex mixture of dolichol-linked oligosaccharides, the trypanosome OST does not show a preference for either the optimal vertebrate donor (Glc<sub>3</sub>Man<sub>9</sub>GlcNAc<sub>2</sub>-PP-Dol) or the native donor (e.g., Man<sub>9</sub>GlcNAc<sub>2</sub>-PP-Dol for *Trypanosoma cruzi*) relative to other compounds in a donor oligosaccharide mix (Bosch *et al.*, 1988). These results suggest that donor-substrate selection is a property of the multi-subunit OST complexes that are expressed in organisms that assemble the triglycosylated oligosaccharide donors. It will now be important to examine the kinetic properties of the OST from organisms that are

predicted to have simpler OST complexes (Figure 2C and D) to determine whether cooperative binding of OS-PP-Dol can be ascribed to the presence of a specific subunit.

## Conclusions

The conclusion that STT3 proteins are the active site subunits of the OST in eukaryotes, archaeobacteria and certain eubacteria ended a three-decade long search for the protein that catalyzes this critical step in glycoprotein biosynthesis. The discovery that the eubacterial enzyme is a single subunit (PglB), rather than the 300-kDa hetero-oligomer present in most eukaryotes, greatly improves the prospect that a high-resolution structure of the OST can be obtained in the foreseeable future. Although the crystallization of a membrane protein is not a trivial endeavor, the successful expression of *C. jejuni* PglB in *E. coli* has paved the way for progress in this area. The expression of PglB in *E. coli* will also allow investigators to examine the OST mechanism in a simpler system. At the same time, it remains clear that there are important differences between the eubacterial and eukaryotic OST in terms of donor- and acceptor-substrate specificity and donor-substrate selection. We can anticipate that analysis of the OST from diverse organisms will reveal new and unexpected findings about this important enzyme.

## Abbreviations

ALG, asparagine-linked glycosylation; Amb, diamino-butanoic acid; CDG, congenital disorders of glycosylation; CSG, cell surface glycoprotein; OS-PP-Dol, dolichol pyrophosphate-linked oligosaccharide; OST, oligosaccharyltransferase; RER, rough endoplasmic reticulum; TM, transmembrane.

## References

- Aebi, M., Gassenhuber, J., Domdey, H., and te Heesen, S. (1996) Cloning and characterization of the *ALG3* gene of *Saccharomyces cerevisiae*. *Glycobiology*, **6**, 439–444.
- Aebi, M. and Hennet, T. (2001) Congenital disorders of glycosylation: genetic model systems lead the way. *Trends Cell Biol.*, **11**, 136–141.
- Allen, S., Naim, H.Y., and Bulleid, N.J. (1995) Intracellular folding of tissue-type plasminogen activator. Effects of disulfide bond formation on N-linked glycosylation and secretion. *J. Biol. Chem.*, **276**, 4797–4804.
- Anand, M., Rush, J.S., Ray, S., Doucey, M.A., Weik, J., Ware, F.E., Hofsteenge, J., Waechter, C.J., and Lehrman, M.A. (2001) Requirement of the *Lec35* gene for all known classes of monosaccharide-P-dolichol-dependent glycosyltransferase reactions in mammals. *Mol. Biol. Cell*, **12**, 487–501.
- Bause, E. (1983) Structural requirements of N-glycosylation of proteins. Studies with proline peptides as conformational probes. *Biochem. J.*, **209**, 331–336.
- Bause, E. (1984) Model studies on N-glycosylation of proteins. *Biochem. Soc. Trans.*, **12**, 514–517.
- Bause, E., Breuer, W., and Peters, S. (1995) Investigation of the active site of oligosaccharyltransferase from pig liver using synthetic tripeptides as tools. *Biochem. J.*, **312**, 979–985.
- Bause, E., Wesemann, M., Bartoschek, A., and Breuer, W. (1997) Epoxyethylglycyl peptides as inhibitors of oligosaccharyltransferase: double-labeling of the active site. *Biochem. J.*, **322**, 95–102.
- Beatson, S. and Ponting, C.P. (2004) GIFT domains: linking eukaryotic intraflagellar transport and glycosylation to bacterial gliding. *Trends Biochem. Sci.*, **29**, 396–399.
- Bickel, T., Lehle, L., Schwarz, M., Aebi, M., and Jakob, C.A. (2005) Biosynthesis of lipid-linked oligosaccharides in *Saccharomyces cerevisiae*: ALG13p and ALG14p form a complex required for the formation of GLcNAc<sub>2</sub>-PP-DOL. *J. Biol. Chem.*, **280**, 34500–34506.
- Bosch, M., Trombetta, S., Engstrom, U., and Parodi, A.J. (1988) Characterization of dolichol diphosphate oligosaccharide: protein oligosaccharyltransferase and glycoprotein-processing glucosidases occurring in trypanosomatid protozoa. *J. Biol. Chem.*, **263**, 17360–17365.
- Breuer, W. and Bause, E. (1995) Oligosaccharyl transferase is a constitutive component of an oligomeric protein complex from pig liver endoplasmic reticulum. *Eur. J. Biochem.*, **228**, 689–696.
- Breuer, W., Klein, R.A., Hardt, B., Bartoschek, A., and Bause, E. (2001) Oligosaccharyltransferase is highly specific for the hydroxy amino acid in Asn-Xaa-Thr/Ser. *FEBS Lett.*, **501**, 106–110.
- Burda, P. and Aebi, M. (1998) The *ALG10* locus of *Saccharomyces cerevisiae* encodes the  $\alpha$ -1,2 glucosyltransferase of the endoplasmic reticulum: the terminal glucose of the lipid-linked oligosaccharide is required for efficient N-linked glycosylation. *Glycobiology*, **8**, 455–462.
- Burda, P. and Aebi, M. (1999) The dolichol pathway of N-linked glycosylation. *Biochim. Biophys. Acta*, **1426**, 239–257.
- Burda, P., te Heesen, S., Brachat, A., Wach, A., Düsterhöft, A., and Aebi, M. (1996) Stepwise assembly of the lipid-linked oligosaccharide in the endoplasmic reticulum of *Saccharomyces cerevisiae*: identification of the *ALG9* gene encoding a putative mannosyl transferase. *Proc. Natl. Acad. Sci. U. S. A.*, **93**, 7160–7165.
- Chantret, I., Dancourt, J., Barbat, A., and Moore, S.E. (2005) Two proteins homologous to the N- and C-terminal domains of the bacterial glycosyltransferase Murg are required for the second step of dolichyl-linked oligosaccharide synthesis in *Saccharomyces cerevisiae*. *J. Biol. Chem.*, **280**, 9236–9242.
- Chantret, I., Dupre, T., Delenda, C., Bucher, S., Dancourt, J., Barnier, A., Charollais, A., Heron, D., Bader-Meunier, B., Danos, O., and others. (2002) Congenital disorders of glycosylation type Ig is defined by a deficiency in dolichyl-P-mannose: Man7GlcNAc<sub>2</sub>-PP-dolichyl mannosyltransferase. *J. Biol. Chem.*, **277**, 25815–25822.
- Chapman, A., Li, E., and Kornfeld, S. (1979) The biosynthesis of the major lipid-linked oligosaccharide of Chinese hamster ovary cells occurs by the ordered addition of mannose residues. *J. Biol. Chem.*, **254**, 10243–10249.
- Chavan, M., Yan, A., and Lennarz, W.J. (2005) Subunits of the translocon interact with components of the oligosaccharyl transferase complex. *J. Biol. Chem.*, **280**, 22917–22924.
- Chen, W., Helenius, J., Braakman, I., and Helenius, A. (1995) Cotranslational folding and calnexin binding during glycoprotein synthesis. *Proc. Natl. Acad. Sci. U. S. A.*, **92**, 6229–6233.
- Chen, X., VanValkenburgh, C., Liang, H., Fang, H., and Green, N. (2001) Signal peptidase and oligosaccharyltransferase interact in a sequential and dependent manner within the endoplasmic reticulum. *J. Biol. Chem.*, **276**, 2411–2416.
- Chi, J.H., Roos, J., and Dean, N. (1996) The OST4 gene of *Saccharomyces cerevisiae* encodes an unusually small protein required for normal levels of oligosaccharyltransferase activity. *J. Biol. Chem.*, **271**, 3132–3140.
- Cipollo, J.F. and Trimble, R.B. (2000) The accumulation of Man<sub>6</sub>GlcNAc<sub>2</sub>-PP-dolichol in the *Saccharomyces cerevisiae*  $\Delta$ alg9 mutant reveals a regulatory role for the Alg3p  $\alpha$ 1,3-Man middle-arm addition in downstream oligosaccharide-lipid and glycoprotein glycan processing. *J. Biol. Chem.*, **275**, 4267–4277.
- Cipollo, J.F., Trimble, R.B., Chi, J.H., Yan, Q., and Dean, N. (2001) The yeast ALG11 gene specifies addition of the terminal alpha 1,2-Man to the Man<sub>3</sub>GlcNAc<sub>2</sub>-PP-dolichol N-glycosylation intermediate formed on the cytosolic side of the endoplasmic reticulum. *J. Biol. Chem.*, **276**, 21828–21840.
- Crimaudo, C., Hortsch, M., Gausepohl, H., and Meyer, D.I. (1987) Human ribophorins I and II: the primary structure and membrane topology of two highly conserved endoplasmic reticulum-specific glycoproteins. *EMBO J.*, **6**, 75–82.
- de la Canal, L. and Parodi, A.J. (1987) Synthesis of dolichol derivatives in trypanosomatids. Characterization of enzymatic patterns. *J. Biol. Chem.*, **262**, 11128–11133.
- Dean, N. (1995) Yeast glycosylation mutants are sensitive to aminoglycosides. *Proc. Natl. Acad. Sci. U. S. A.*, **92**, 1287–1291.
- Dempski, R.E. Jr. and Imperiali, B. (2002) Oligosaccharyl transferase: gatekeeper to the secretory pathway. *Curr. Opin. Chem. Biol.*, **6**, 844–850.

- Fang, X., Gibbs, B.S., and Coward, J.K. (1995) Synthesis and evaluation of synthetic analogues of dolichyl-P-P-chitobiose as oligosaccharyltransferase substrates. *Bioorg. Med. Chem. Lett.*, **5**, 2701–2706.
- Feldman, M.F., Wacker, M., Hernandez, M., Hitchen, P.G., Marolda, C.L., Kowarik, M., Morris, H.R., Dell, A., Valvano, M.A., and Aebi, M. (2005) Engineering N-linked protein glycosylation with diverse O antigen lipopolysaccharide structures in *Escherichia coli*. *Proc. Natl. Acad. Sci. U. S. A.*, **102**, 3016–3021.
- Fetrow, J.S., Siew, N., Di Gennaro, J.A., Martinez-Yamout, M., Dyson, H.J., and Skolnick, J. (2001) Genomic-scale comparison of sequence- and structure-based methods of function prediction: does structure provide additional insight? *Protein Sci.*, **10**, 1005–1014.
- Frank, C.G. and Aebi, M. (2005) ALG9 mannosyltransferase is involved in two different steps of lipid-linked oligosaccharide biosynthesis. *Glycobiology*, **15**, 1156–1163.
- Frank, C.G., Grubenmann, C.E., Eyaid, W., Berger, E.G., Aebi, M., and Hennet, T. (2004) Identification and functional analysis of a defect in the human *ALG9* gene: definition of congenital disorder of glycosylation type II. *Am. J. Hum. Genet.*, **75**, 146–150.
- Fraser, A.G., Kamath, R.S., Zipperlen, P., Martinez-Campos, M., Sohrmann, M., and Ahringer, J. (2000) Functional genomic analysis of *C. elegans* chromosome I by systematic RNA interference. *Nature*, **408**, 325–330.
- Freeze, H.H. and Aebi, M. (2005) Altered glycan structures: the molecular basis of congenital disorders of glycosylation. *Curr. Opin. Struct. Biol.*, **15**, 490–498.
- Fu, J. and Kreibich, G. (2000) Retention of subunits of the oligosaccharyltransferase complex in the endoplasmic reticulum. *J. Biol. Chem.*, **275**, 3984–3990.
- Fu, J., Ren, M., and Kreibich, G. (1997) Interactions among subunits of the oligosaccharyltransferase complex. *J. Biol. Chem.*, **272**, 29687–29692.
- Gao, X.D., Tachikawa, H., Sato, T., Jigami, Y., and Dean, N. (2005) Alg14 recruits Alg13 to the cytoplasmic face of the endoplasmic reticulum to form a novel bipartite UDP-N-acetylglucosamine transferase required for the second step of N-linked glycosylation. *J. Biol. Chem.*, **280**, 36254–36262.
- Gavel, Y. and Von Heijne, G. (1990) Sequence differences between glycosylated and non-glycosylated Asn-X-Thr/Ser acceptor sites: implications for protein engineering. *Protein Eng.*, **3**, 433–442.
- Gaynor, E.C., te Heesen, S., Graham, T.R., Aebi, M., and Emr, S.D. (1994) Signal-mediated retrieval of a membrane protein from the Golgi to the ER in yeast. *J. Cell Biol.*, **127**, 653–665.
- Gibbs, B.S. and Coward, J.K. (1999) Dolichylpyrophosphate oligosaccharides: large scale isolation and evaluation as oligosaccharyltransferase substrates. *Bioorg. Med. Chem.*, **7**, 441–447.
- Gonczy, P., Echeverri, C., Oegema, K., Coulson, A., Jones, S.J., Copley, R.R., Duperon, J., Oegema, J., Brehm, M., Cassin, E., and others. (2000) Functional genomic analysis of cell division in *C. elegans* using RNAi of genes on chromosome III. *Nature*, **408**, 331–336.
- Green, N. and Walter, P. (1992) C-terminal sequences can inhibit the insertion of membrane proteins into the endoplasmic reticulum of *Saccharomyces cerevisiae*. *Mol. Cell Biol.*, **12**, 283–291.
- Grubenmann, C.E., Frank, C.G., Hulsmeier, A.J., Schollen, E., Matthijs, G., Mayatepek, E., Berger, E.G., Aebi, M., and Hennet, T. (2004) Deficiency of the first mannosylation step in the N-glycosylation pathway causes congenital disorder of glycosylation type I. *Hum. Mol. Genet.*, **13**, 535–542.
- Helenius, A. and Aebi, M. (2004) Roles of N-linked glycans in the endoplasmic reticulum. *Annu. Rev. Biochem.*, **73**, 1019–1049.
- Helenius, J., Ng, D.T., Marolda, C.L., Walter, P., Valvano, M.A., and Aebi, M. (2002) Translocation of lipid-linked oligosaccharides across the ER membrane requires Rft1 protein. *Nature*, **415**, 447–450.
- Hendrickson, T. and Imperiali, B. (1995) Metal ion dependence of oligosaccharyl transferase: implications for catalysis. *Biochemistry*, **34**, 9444–9450.
- Hendrickson, T.L., Spencer, J.R., Kato, M., and Imperiali, B. (1996) Design and evaluation of potent inhibitors of asparagine-linked glycosylation. *J. Am. Chem. Soc.*, **118**, 7636–7637.
- Hresko, R.C., Kruse, M., Strube, M., and Mueckler, M. (1994) Topology of the Glut 1 glucose transporter deduced from glycosylation scanning mutagenesis. *J. Biol. Chem.*, **269**, 20482–20488.
- Huffaker, T.C. and Robbins, P.W. (1983) Yeast mutants deficient in protein glycosylation. *Proc. Natl. Acad. Sci. U. S. A.*, **80**, 7466–7470.
- Imperiali, B. and Shannon, K.L. (1991) Differences between Asn-Xaa-Thr containing peptides: a comparison of solution conformation and substrate behaviour with oligosaccharyltransferase. *Biochemistry*, **30**, 4374–4380.
- Imperiali, B., Shannon, K.L., and Rickert, K.W. (1992) Role of peptide conformation in asparagine linked glycosylation. *J. Am. Chem. Soc.*, **114**, 7942–7944.
- Iwata, Y. and Koizumi, N. (2005) Unfolded protein response followed by induction of cell death in cultured tobacco cells treated with tunicamycin. *Planta*, **220**, 804–807.
- Kaiden, A., Rosenwald, A.G., Cacan, R., Verbert, A., and Krag, S.S. (1998) Transfer of two oligosaccharides to protein in a Chinese hamster ovary cell B211 which utilizes polyphenol for its N-linked glycosylation intermediates. *Arch. Biochem. Biophys.*, **358**, 303–312.
- Kamath, R.S., Fraser, A.G., Dong, Y., Poulin, G., Durbin, R., Gotta, M., Kanapin, A., Le Bot, N., Moreno, S., Sohrmann, M., and others. (2003) Systematic functional analysis of the *Caenorhabditis elegans* genome using RNAi. *Nature*, **421**, 231–237.
- Karamyshev, A.L., Kelleher, D.J., Gilmore, R., Johnson, A.E., Von Heijne, G., and Nilsson, I. (2005) Mapping the interaction of the STT3 subunit of the oligosaccharyl transferase complex with nascent polypeptide chains. *J. Biol. Chem.*, **280**, 40489–40493.
- Karaoglu, D., Kelleher, D.J., and Gilmore, R. (1995) Functional characterization of the Ost3p subunit of the *Saccharomyces cerevisiae* oligosaccharyltransferase: disruption of the *OST3* gene causes biased underglycosylation of acceptor substrates. *J. Cell Biol.*, **130**, 567–577.
- Karaoglu, D., Kelleher, D.J., and Gilmore, R. (1997) The highly conserved Stt3 protein is a subunit of the yeast oligosaccharyltransferase and forms a subcomplex with Ost3p and Ost4p. *J. Biol. Chem.*, **272**, 32513–32520.
- Karaoglu, D., Kelleher, D.J., and Gilmore, R. (2001) Allosteric regulation provides a molecular mechanism for preferential utilization of the fully assembled dolichol-linked oligosaccharide by the yeast oligosaccharyltransferase. *Biochemistry*, **40**, 12193–12206.
- Kelleher, D.J. and Gilmore, R. (1994) The *Saccharomyces cerevisiae* oligosaccharyltransferase is a protein complex composed of Wbp1p, Swp1p and four additional polypeptides. *J. Biol. Chem.*, **269**, 12908–12917.
- Kelleher, D.J. and Gilmore, R. (1997) DAD1, the defender against apoptotic cell death, is a subunit of the mammalian oligosaccharyltransferase. *Proc. Natl. Acad. Sci. U. S. A.*, **94**, 4994–4999.
- Kelleher, D.J., Karaoglu, D., and Gilmore, R. (2001) Large-scale isolation of dolichol-linked oligosaccharides with homogeneous oligosaccharide structures: determination of steady-state dolichol-linked oligosaccharide compositions. *Glycobiology*, **11**, 321–333.
- Kelleher, D.J., Karaoglu, D., Mandon, E.C., and Gilmore, R. (2003) Oligosaccharyltransferase isoforms that contain different catalytic STT3 subunits have distinct enzymatic properties. *Mol. Cell*, **12**, 101–111.
- Kelleher, D.J., Kreibich, G., and Gilmore, R. (1992) Oligosaccharyltransferase activity is associated with a protein complex composed of ribophorins I and II and a 48 kD protein. *Cell*, **69**, 55–65.
- Kellenberger, C., Hendrickson, T.I., and Imperiali, B. (1997) Structural and functional analysis of peptidyl oligosaccharyl transferase inhibitors. *Biochemistry*, **36**, 12554–12559.
- Kim, H., Melen, K., and von Heijne, G. (2003) Topology models for 37 *Saccharomyces cerevisiae* membrane proteins based on C-terminal reporter fusions and predictions. *J. Biol. Chem.*, **278**, 10208–10213.
- Kim, H., Park, H., Montalvo, L., and Lennarz, W.J. (2000) Studies on the role of the hydrophobic domain of Ost4p in interactions with other subunits of yeast oligosaccharyl transferase. *Proc. Natl. Acad. Sci. U. S. A.*, **97**, 1516–1520.
- Kim, H., von Heijne, G., and Nilsson, I. (2005) Membrane topology of the STT3 subunit of the oligosaccharyl transferase complex. *J. Biol. Chem.*, **280**, 20261–20267.
- Kim, H., Yan, Q., Von Heijne, G., Caputo, G.A., and Lennarz, W.J. (2003) Determination of the membrane topology of Ost4p and its subunit interactions in the oligosaccharyltransferase complex in *Saccharomyces cerevisiae*. *Proc. Natl. Acad. Sci. U. S. A.*, **100**, 7460–7464.
- Knauer, R. and Lehle, L. (1994) The N-oligosaccharyltransferase complex from yeast. *FEBS Lett.*, **344**, 83–86.
- Knauer, R. and Lehle, L. (1999) The oligosaccharyltransferase complex from *Saccharomyces cerevisiae*. Isolation of the *OST6* gene, its synthetic interaction with *OST3*, and analysis of the native complex. *J. Biol. Chem.*, **274**, 17249–17256.

- Korner, C., Knauer, R., Stephani, U., Marquardt, T., Lehle, L., and von Figura, K. (1999) Carbohydrate deficient glycoprotein syndrome type IV: deficiency of dolichyl-P-Man: Man<sub>5</sub>GlcNAc<sub>2</sub>-PP-dolichyl mannosyltransferase. *EMBO J.*, **18**, 6816–6822.
- Kranz, C., Denecke, J., Lehrman, M.A., Ray, S., Kienz, P., Kreissel, G., Sagi, D., Peter-Katalinic, J., Freeze, H.H., Schmid, T., and others. (2001) A mutation in the human MPDU1 gene causes congenital disorder of glycosylation type If (CDG-If). *J. Clin. Invest.*, **108**, 1613–1619.
- Kreibich, G., Czako-Graham, M., Grebenau, R., Mok, W., Rodriguez-Boulan, E., and Sabatini, D.D. (1978) Characterization of the ribosomal binding site in rat liver rough microsomes: ribophorins I and II, two integral membrane proteins related to ribosome binding. *J. Supramol. Struct.*, **8**, 279–302.
- Kuntz, C., Sonnenbichler, J., Sonnenbichler, I., Sumper, M., and Zeitler, R. (1997) Isolation and characterization of dolichol-linked oligosaccharides from *Haloflex volcanii*. *Glycobiology*, **7**, 897–904.
- Lechner, J. and Wieland, F. (1989) Structure and biosynthesis of prokaryotic glycoproteins. *Annu. Rev. Biochem.*, **58**, 173–194.
- Lechner, J., Wieland, F., and Sumper, M. (1985) Biosynthesis of sulfated saccharides N-glycosidically linked to the protein via glucose. Purification and identification of sulfated dolichyl monophosphoryl tetrasaccharides from halobacteria. *J. Biol. Chem.*, **260**, 860–866.
- Lehrman, M.A. and Zeng, Y. (1989) Pleiotropic resistance of glycoprotein processing inhibitors in Chinese hamster ovary cells. The role of a novel mutation in the asparagine-linked glycosylation pathway. *J. Biol. Chem.*, **264**, 1584–1593.
- Li, G., Yan, Q., Oen, H.O., and Lennarz, W.J. (2003) A specific segment of the transmembrane domain of Wbp1p is essential for its incorporation into the oligosaccharyl transferase complex. *Biochemistry*, **42**, 11032–11039.
- Lissy, N.A., Bellacosa, A., Sonoda, G., Miller, P.D., Jhanwar, S.C., and Testa, J.R. (1996) Isolation, characterization, and mapping to human chromosome 11q24-25 of a cDNA encoding a highly conserved putative transmembrane protein, TMC. *Biochim. Biophys. Acta*, **1306**, 137–141.
- Liu, T., Stetson, B., Turco, S.J., Hubbard, S.C., and Robbins, P.W. (1979) Arrangement of glucose residues in the lipid-linked oligosaccharide precursor of asparaginyl oligosaccharides. *J. Biol. Chem.*, **254**, 4554–4559.
- Lockridge, O., Bartels, C.F., Vaughan, T.A., Wong, C.K., Norton, S.E., and Johnson, L.L. (1987) Complete amino acid sequence of human serum cholinesterase. *J. Biol. Chem.*, **262**, 549–557.
- MacGrogan, D., Levy, A., Bova, G.S., Isaacs, W.B., and Bookstein, R. (1996) Structure and methylation-associated silencing of a gene within a homozygously deleted region of human chromosome band 8p22. *Genomics*, **35**, 55–65.
- Makishima, T., Nakashima, T., Nagata-Kuno, K., Fukushima, K., Iida, H., Sakaguchi, M., Ikehara, Y., Komiyama, S., and Nishimoto, T. (1997) The highly conserved DAD1 protein involved in apoptosis is required for N-linked glycosylation. *Genes Cells*, **2**, 129–141.
- Marcantonio, E.E., Amar-Costesec, A., and Kreibich, G. (1984) Segregation of the polypeptide translocation apparatus to regions of the endoplasmic reticulum containing ribophorins and ribosomes. II. Rat liver microsomal subfractions contain equimolar amounts of ribophorins and ribosomes. *J. Cell. Biol.*, **99**, 2254–2259.
- Marshall, R.D. (1972) Glycoproteins. *Annu. Rev. Biochem.*, **41**, 673–702.
- McBride, K., Baron, C., Picard, S., Martin, S., Boismenu, D., Bell, A., Bergeron, J., and Perreault, C. (2002) The model B6 (dom1) minor histocompatibility antigen is encoded by a mouse homolog of the yeast *STT3* gene. *Immunogenetics*, **54**, 562–569.
- McGinnes, L.W. and Morrison, T.G. (1994) The role of individual cysteine residues in the formation of the mature, antigenic HN protein of Newcastle disease virus. *Virology*, **200**, 470–483.
- Miletich, J.P. and Broze, G.J.J. (1990)  $\beta$  protein C is not glycosylated at asparagine 329. *J. Biol. Chem.*, **265**, 11397–11404.
- Nakashima, T., Sekiguchi, T., Kuraoka, A., Fukushima, K., Shibata, Y., Komiyama, S., and Nishimoto, T. (1993) Molecular cloning of a human cDNA encoding a novel protein, DAD1, whose defect causes apoptotic cell death in hamster BHK21 cells. *Mol. Cell Biol.*, **13**, 6367–6374.
- Nilsson, I., Kelleher, D.J., Miao, Y., Shao, Y., Kreibich, G., Gilmore, R., Von Heijne, G., and Johnson, A.E. (2003) Photocross-linking of nascent chains to the STT3 subunit of the oligosaccharyltransferase complex. *J. Cell Biol.*, **161**, 715–725.
- Nilsson, I. and von Heijne, G. (1993) Determination of the distance between the oligosaccharyltransferase active site and the endoplasmic reticulum membrane. *J. Biol. Chem.*, **268**, 5798–5801.
- Nita-Lazar, M., Wacker, M., Schegg, B., Amber, S., and Aebi, M. (2005) The N-X/S/T consensus sequence is required but not sufficient for bacterial N-linked protein glycosylation. *Glycobiology*, **15**, 361–367.
- Parodi, A.J. (2000) Protein glucosylation and its role in protein folding. *Annu. Rev. Biochem.*, **69**, 69–93.
- Pathak, R., Hendrickson, T.L., and Imperiali, B. (1995) Sulfhydryl modification of the yeast Wbp1p inhibits oligosaccharyl transferase activity. *Biochemistry*, **34**, 4179–4185.
- Pathak, R. and Imperiali, B. (1997) A dual affinity tag on the 64-kDa Nlt1p subunit allows the rapid characterization of mutant yeast oligosaccharyl transferase complexes. *Arch. Biochem. Biophys.*, **338**, 1–6.
- Paul, G., Lottspeich, F., and Wieland, F. (1986) Asparaginyl-N-acetylglactosamine. Linkage unit of halobacterial glycosaminoglycan. *J. Biol. Chem.*, **261**, 1020–1024.
- Peluso, S., de L. Ufret, M., O'Reilly, M.K., and Imperiali, B. (2002) Neoglycopeptides as inhibitors of oligosaccharyl transferase: insight into negotiating product inhibition. *Chem. Biol.*, **9**, 1323–1328.
- Pérez-Salva, D. and Mollinedo, F. (1995) Inhibition of N-linked glycosylation induces early apoptosis in human promyelocytic HL-60 cells. *J. Cell. Physiol.*, **163**, 523–531.
- Petrescu, A.J., Milac, A.L., Petrescu, S.M., Dwek, R.A., and Wormald, M.R. (2004) Statistical analysis of the protein environment of N-glycosylation sites: implications for occupancy, structure, and folding. *Glycobiology*, **14**, 103–114.
- Popov, M., Tam, L.Y., Li, J., and Reithmeier, R.A. (1997) Mapping the ends of transmembrane segments in a polytopic membrane protein. Scanning N-glycosylation mutagenesis of extracytosolic loops in the anion exchanger, band 3. *J. Biol. Chem.*, **272**, 18325–18332.
- Reddy, A., Gibbs, B.S., Liu, Y.L., Coward, J.K., Changchien, L.M., and Maley, F. (1999) Glycosylation of the overlapping sequons in yeast external invertase: effect of amino acid variation on site selectivity in vivo and in vitro. *Glycobiology*, **9**, 547–555.
- Reddy, V.A., Johnson, R.S., Biemann, K., Williams, R.S., Ziegler, F.D., Trimble, R.B., and Maley, F. (1988) Characterization of the glycosylation sites in yeast external invertase. I. N-linked oligosaccharide content of the individual sequons. *J. Biol. Chem.*, **263**, 6978–6985.
- Reiss, G., te Heesen, S., Gilmore, R., Zufferey, R., and Aebi, M. (1997) A specific screen for oligosaccharyltransferase mutations identifies the 9 kDa OST5 protein required for optimal activity in vivo and in vitro. *EMBO J.*, **16**, 1164–1172.
- Reiss, G., te Heesen, S., Zimmerman, J., Robbins, P.W., and Aebi, M. (1996) Isolation of the *ALG6* locus of *Saccharomyces cerevisiae* required for glucosylation in the N-linked glycosylation pathway. *Glycobiology*, **6**, 493–498.
- Rosenfeld, M.G., Marcantonio, E.E., Hakimi, J., Ort, V.M., Atkinson, P.H., Sabatini, D.D., and Kreibich, G. (1984) Biosynthesis and processing of ribophorins in the endoplasmic reticulum. *J. Cell Biol.*, **99**, 1076–1082.
- Samuelson, J., Banerjee, S., Magnelli, P., Cui, J., Kelleher, D.J., Gilmore, R., and Robbins, P.W. (2005) The diversity of dolichol-linked precursors to Asn-linked glycans likely results from secondary loss of sets of glycosyltransferases. *Proc. Natl. Acad. Sci. U. S. A.*, **102**, 1548–1553.
- Sanjay, A., Fu, J., and Kreibich, G. (1998) DAD1 is required for the function and the structural integrity of the oligosaccharyltransferase complex. *J. Biol. Chem.*, **273**, 26094–26099.
- Schenk, B., Imbach, T., Frank, C.G., Grubenmann, C.E., Raymond, G.V., Hurvitz, H., Korn-Lubetzki, I., Revel-Vik, S., Raas-Rotschild, A., Luder, A.S., and others. (2001) MPDU1 mutations underlie a novel human congenital disorder of glycosylation, designated type If. *J. Clin. Invest.*, **108**, 1687–1695.
- Schollen, E., Frank, C.G., Keldermans, L., Reyntjens, R., Grubenmann, C.E., Clayton, P.T., Winchester, B.G., Smeitink, J., Wevers, R.A., Aebi, M., and others. (2004) Clinical and molecular features of three patients with congenital disorders of glycosylation type Ih (CDG-Ih) (ALG8 deficiency). *J. Med. Genet.*, **41**, 550–556.
- Schrag, J.D., Procopio, D.O., Cygler, M., Thomas, D.Y., and Bergeron, J.J. (2003) Lectin control of protein folding and sorting in the secretory pathway. *Trends Biochem. Sci.*, **28**, 49–57.



- Shakin-Eshleman, S.H., Spitalnik, S.L., and Kasturi, L. (1996) The amino acid at the X position of an Asn-X-Ser sequon is an important determinant of N-linked core-glycosylation efficiency. *J. Biol. Chem.*, **271**, 6363–6366.
- Sharma, C.B., Lehle, L., and Tanner, W. (1981) N-glycosylation of yeast proteins. Characterization of the solubilized oligosaccharyltransferase. *Eur. J. Biochem.*, **116**, 101–108.
- Shibatani, T., David, L.L., McCormack, A.L., Frueh, K., and Skach, W.R. (2005) Proteomic analysis of mammalian oligosaccharyltransferase reveals multiple subcomplexes that contain Sec61, TRAP, and two potential new subunits. *Biochemistry*, **44**, 5982–5992.
- Silberstein, S., Collins, P.G., Kelleher, D.J., and Gilmore, R. (1995) The essential *OST2* gene encodes the 16-kD subunit of the yeast oligosaccharyltransferase, a highly conserved protein expressed in diverse eukaryotic organisms. *J. Cell Biol.*, **131**, 371–383.
- Silberstein, S., Collins, P.G., Kelleher, D.J., Rapiejko, P.J., and Gilmore, R. (1995) The alpha subunit of the *Saccharomyces cerevisiae* oligosaccharyltransferase complex is essential for vegetative growth of yeast and is homologous to mammalian ribophorin I. *J. Cell Biol.*, **128**, 525–536.
- Silberstein, S. and Gilmore, R. (1996) Biochemistry, molecular biology, and genetics of the oligosaccharyltransferase. *FASEB J.*, **10**, 849–858.
- Silberstein, S., Kelleher, D.J., and Gilmore, R. (1992) The 48 kDa subunit of the mammalian oligosaccharyltransferase complex is homologous to the essential yeast protein WP1. *J. Biol. Chem.*, **267**, 23658–23663.
- Spirig, U., Bodmer, D., Wacker, M., Burda, P., and Aebi, M. (2005) The 3.4 kDa Ost4 protein is required for the assembly of two distinct oligosaccharyltransferase complexes in yeast. *Glycobiology*, **15**, 1396–1406.
- Spirig, U., Glavas, M., Bodmer, D., Reiss, G., Burda, P., Lippuner, V., te Heesen, S., and Aebi, M. (1997) The STT3 protein is a component of the yeast oligosaccharyltransferase complex. *Mol. Gen. Genet.*, **256**, 628–637.
- Szymanski, C.M. and Wren, B.W. (2005) Protein glycosylation in bacterial mucosal pathogens. *Nat. Rev. Microbiol.*, **3**, 225–237.
- Szymanski, C.M., Yao, R., Ewing, C.P., Trust, T.J., and Guerry, P. (1999) Evidence for a system of general protein glycosylation in *Campylobacter jejuni*. *Mol. Microbiol.*, **32**, 1022–1030.
- Tai, V.W. and Imperiali, B. (2001) Substrate specificity of the glycosyl donor for oligosaccharyl transferase. *J. Org. Chem.*, **66**, 6217–6228.
- te Heesen, S., Janetzky, B., Lehle, L., and Aebi, M. (1992) The yeast WP1 is essential for oligosaccharyltransferase activity in vivo and in vitro. *EMBO J.*, **11**, 2071–2075.
- te Heesen, S., Knauer, R., Lehle, L., and Aebi, M. (1993) Yeast Wbp1p and Swp1p form a protein complex essential for oligosaccharyl transferase activity. *EMBO J.*, **12**, 279–284.
- te Heesen, S., Rauhut, R., Aebersold, R., Abelson, J., Aebi, M., and Clark, M.W. (1991) An essential 45 kDa yeast transmembrane protein reacts with anti-nuclear pore antibodies: purification of the protein, immunolocalization and cloning of the gene. *Eur. J. Cell Biol.*, **56**, 8–18.
- Thiel, C., Schwarz, M., Peng, J., Grzmil, M., Hasilik, M., Bräulke, T., Kohlschütter, A., von Figura, K., Lehle, L., and Korner, C. (2003) A new type of congenital disorders of glycosylation (CDG-Ii) provides new insights into the early steps of dolichol-linked oligosaccharide biosynthesis. *J. Biol. Chem.*, **278**, 22498–22505.
- Titani, K., Kumar, S., Takio, K., Ericsson, L.H., Wade, R.D., Ashida, K., Walsh, K.A., Chopek, M.W., Sadler, J.E., and Fujikawa, K. (1986) Amino acid sequence of human von Willebrand factor. *Biochemistry*, **25**, 3171–3184.
- Trimble, R.B., Byrd, J.C., and Maley, F. (1980) Effect of glycosylation of lipid intermediates on oligosaccharide transfer in solubilized microsomes from *Saccharomyces cerevisiae*. *J. Biol. Chem.*, **255**, 11892–11895.
- Turco, S.J., Stetson, B., and Robbins, P.W. (1977) Comparative rates of transfer of lipid-linked oligosaccharides to endogenous glycoprotein acceptors in vitro. *Proc. Natl. Acad. Sci. U. S. A.*, **74**, 4410–4414.
- Verostek, M.F., Atkinson, P.H., and Trimble, R.B. (1993) Glycoprotein biosynthesis in the *alg3 Saccharomyces cerevisiae* mutant I. Role of glucose in the initial glycosylation of invertase in the endoplasmic reticulum. *J. Biol. Chem.*, **268**, 12095–12103.
- Voisin, S., Houliston, R.S., Kelly, J., Brisson, J.R., Watson, D., Bardy, S.L., Jarrell, K.F., and Logan, S.M. (2005) Identification and characterization of the unique N-linked glycan common to the flagellins and S-layer glycoprotein of *Methanococcus voltae*. *J. Biol. Chem.*, **280**, 16586–16593.
- Wacker, M., Linton, D., Hitchen, P.G., Nita-Lazar, M., Haslam, S.M., North, S.J., Panico, M., Morris, H.R., Dell, A., Wren, B.W., and Aebi, M. (2002) N-linked glycosylation in *C. jejuni* and its functional transfer to *E. coli*. *Science*, **298**, 1790–1793.
- Walker, B.K., Lei, H., and Krag, S.S. (1998) A functional link between N-linked glycosylation and apoptosis in Chinese hamster ovary cells. *Biochem. Biophys. Res. Commun.*, **250**, 264–270.
- Welpley, J.K., Shenbagamurthi, P., Lennarz, W.J., and Naider, F. (1983) Substrate recognition by oligosaccharyltransferase. Studies on glycosylation of modified asn-x-thr/ser tripeptides. *J. Biol. Chem.*, **258**, 11856–11863.
- Whitley, P., Nilsson, I.M., and von Heijne, G. (1996) A nascent secretory protein may traverse the ribosome/endoplasmic reticulum translocase complex as an extended chain. *J. Biol. Chem.*, **271**, 6241–6244.
- Wieland, F., Heitzer, R., and Schaefer, W. (1983) Asparaginylglucose: novel type of carbohydrate linkage. *Proc. Natl. Acad. Sci. U. S. A.*, **80**, 5470–5474.
- Wieland, F., Paul, G., and Sumper, M. (1985) Halobacterial flagellins are sulfated glycoproteins. *J. Biol. Chem.*, **260**, 15180–15185.
- Wilson, C.M., Kraft, C., Duggan, C., Ismail, N., Crawshaw, S.G., and High, S. (2005) Ribophorin I associates with a subset of membrane proteins after their integration at the Sec61 translocon. *J. Biol. Chem.*, **280**, 4195–4206.
- Wu, X., Rush, J.S., Karaoglu, D., Krasnewich, D., Lubinsky, M.S., Waechter, C.J., Gilmore, R., and Freeze, H.H. (2003) Deficiency of UDP-GlcNAc: dolichol phosphate N-acetylglucosamine-1 phosphate transferase (DPAGT1) causes a novel congenital disorder of glycosylation type Ij. *Hum. Mutat.*, **22**, 144–150.
- Xu, T., Khanna, H., and Coward, J.K. (1998) The design, synthesis, and initial evaluation of benzophenone-containing peptides as potential photoaffinity labels of oligosaccharyltransferase. *Bioorg. Med. Chem.*, **6**, 1821–1834.
- Xu, T., Werner, M., Lee, K.-C., Fettingner, J.C., Davis, J.T., and Coward, J.K. (1998) Synthesis and evaluation of tripeptides containing asparagine analogues as potential substrates or inhibitors of oligosaccharyltransferase. *J. Org. Chem.*, **63**, 4767–4778.
- Yan, A., Ahmed, E., Yan, Q., and Lennarz, W.J. (2003) New findings on interactions among the yeast oligosaccharyl transferase subunits using a chemical cross-linker. *J. Biol. Chem.*, **278**, 33078–33087.
- Yan, A. and Lennarz, W.J. (2005) Unraveling the mechanism of protein N-glycosylation. *J. Biol. Chem.*, **280**, 3121–3124.
- Yan, A., Wu, E., and Lennarz, W.J. (2005) Studies of yeast oligosaccharyl transferase subunits using the split-ubiquitin system: topological features and in vivo interactions. *Proc. Natl. Acad. Sci. U. S. A.*, **102**, 7121–7126.
- Yan, Q. and Lennarz, W.J. (2002a) Studies on the function of oligosaccharyl transferase subunits: a glycosylatable photoprobe binds to the luminal domain of Ost1p. *Proc. Natl. Acad. Sci. U. S. A.*, **99**, 15994–15999.
- Yan, Q. and Lennarz, W.J. (2002b) Studies on the function of the oligosaccharyltransferase subunits: Stt3p is directly involved in the glycosylation process. *J. Biol. Chem.*, **277**, 47692–47700.
- Yan, Q., Prestwich, G.D., and Lennarz, W.J. (1999) The Ost1p subunit of yeast oligosaccharyl transferase recognizes the peptide glycosylation site sequence-Asn-X-Ser/Thr. *J. Biol. Chem.*, **274**, 5021–5025.
- Yoshida, S., Ikeda, E., Uno, I., and Mitsuzawa, H. (1992) Characterization of a staurosporine- and temperature-sensitive mutant, *stt1*, of *Saccharomyces cerevisiae*: *STT1* is allelic to *PKC1*. *Mol. Gen. Genet.*, **231**, 337–344.
- Yoshida, S., Ohya, Y., Nakano, A., and Anraku, Y. (1995) *STT3*, a novel essential gene related to *PKC1/STT1* protein kinase pathway, is involved in protein glycosylation in yeast. *Gene*, **164**, 167–172.
- Young, N.M., Brisson, J.R., Kelly, J., Watson, D.C., Tessier, L., Lanthier, P.H., Jarrell, H.C., Cadotte, N., St. Michael, F., Aberg, E., and Szymanski, C.M. (2002) Structure of the N-linked glycan present on multiple glycoproteins in the gram-negative bacterium, *Campylobacter jejuni*. *J. Biol. Chem.*, **277**, 42530–42539.
- Yu, Y., Sabatini, D.D., and Kreibich, G. (1990) Antiribophorin antibodies inhibit the targeting to the ER membrane of ribosomes containing secretory polypeptides. *J. Cell Biol.*, **111**, 1335–1342.
- Zeitler, R., Hochmuth, E., Deutzmann, R., and Sumper, M. (1998) Exchange of Ser-4 for Val, Leu or Asn in the sequon Asn-Ala-Ser does not prevent N-glycosylation of the cell surface glycoprotein from *Halobacterium halobium*. *Glycobiology*, **8**, 1157–1164.
- Zufferey, R., Knauer, R., Burda, P., Stagljar, I., te Heesen, S., Lehle, L., and Aebi, M. (1995) *STT3*, a highly conserved protein required for yeast oligosaccharyl transferase activity in vivo. *EMBO J.*, **14**, 4949–4960.