

 Open access • Journal Article • DOI:10.2307/1885061

## **An Extension of the Second Welfare Theorem to Economies with Nonconvexities and Public Goods — [Source link](#)**

M. Ali Khan, Rajiv Vohra

**Institutions:** University of Illinois at Urbana–Champaign, Brown University

**Published on:** 01 May 1987 - Quarterly Journal of Economics (Oxford University Press)

**Topics:** Marginal cost

Related papers:

- [Pareto optimality in non-convex economies](#)
- [Optimization and nonsmooth analysis](#)
- [Theory of Value](#)
- [On Marginal Cost Pricing with Given Tax-Subsidy Rules\\*](#)
- [Lindahl's solution and the core of an economy with public goods](#)

Share this paper:    

View more about this paper here: <https://typeset.io/papers/an-extension-of-the-second-welfare-theorem-to-economies-with-2li2mnbmy1>







UNIVERSITY OF  
ILLINOIS LIBRARY  
AT URBANA-CHAMPAIGN  
BOOKSTACKS

B24 E 2-3



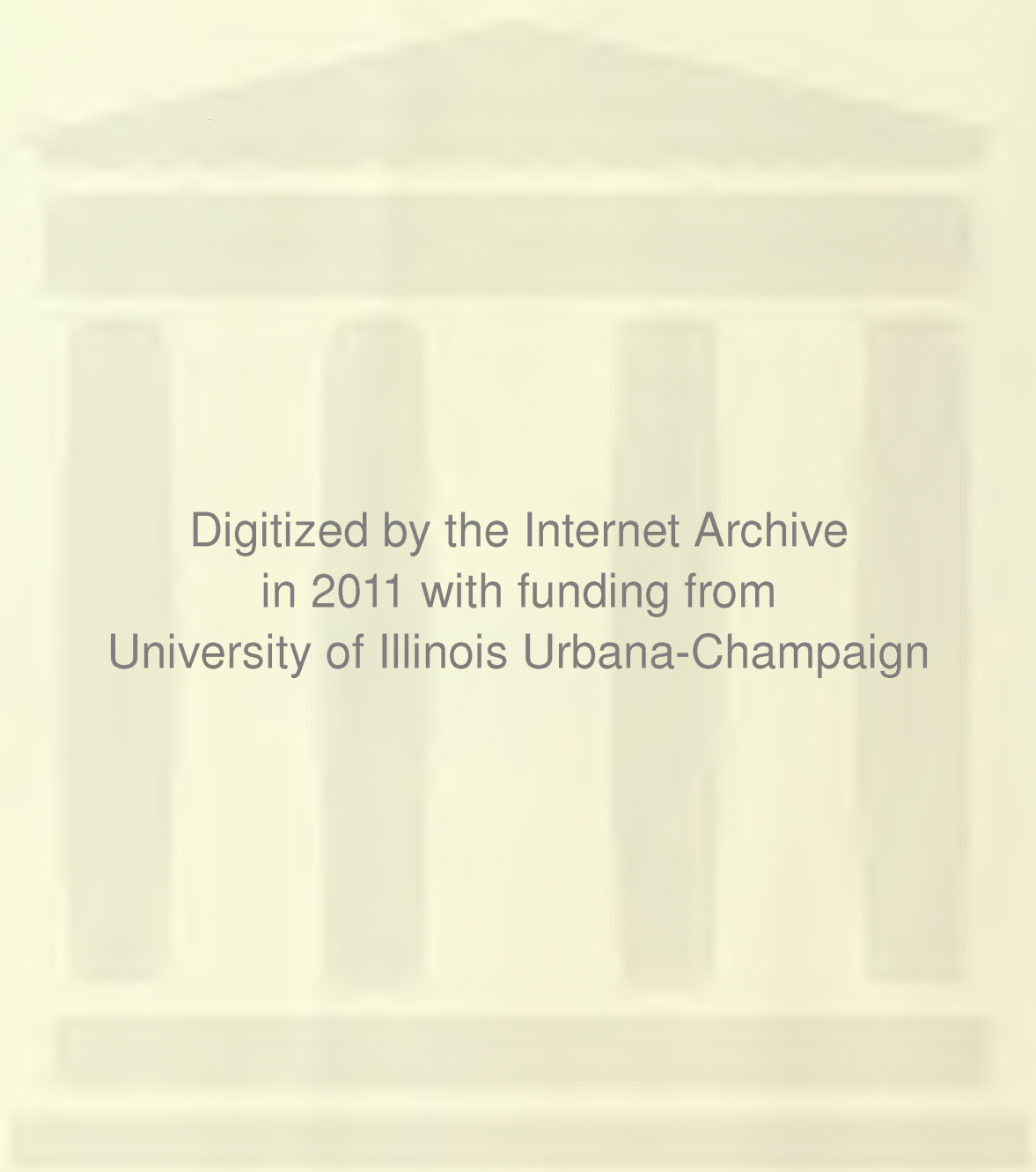

Digitized by the Internet Archive  
in 2011 with funding from  
University of Illinois Urbana-Champaign

<http://www.archive.org/details/extensionofsecon1290khan>

201-143



# BEBR

FACULTY WORKING  
PAPER NO. 1290

An Extension of the Second Welfare Theorem to  
Economies with Nonconvexities and Public Goods

*M. Ali Khan*  
*Rajiv Vohra*

College of Commerce and Business Administration  
Bureau of Economic and Business Research  
University of Illinois, Urbana-Champaign





# **BEBR**

FACULTY WORKING PAPER NO. 1290

College of Commerce and Business Administration

University of Illinois at Urbana-Champaign

October 1986

An Extension of the Second Welfare Theorem to  
Economies with Nonconvexities and Public Goods

M. Ali Khan, Professor  
Department of Economics

Rajiv Vohra  
Brown University

\*The first version of this paper was circulated in October 1984. Preliminary versions were presented at the Indian Statistical Institute, London School of Economics, University of Minnesota, Purdue University and the Fifth World Congress of the Econometric Society, Cambridge (1985). At the World Congress Martine Quinzii and later Kwan Koo Yun brought to our attention that they had independently proved versions of our Theorem 1 using different arguments. The authors are grateful to the participants of the seminars, to James Foster, Terrence Gorman and two anonymous referees whose comments led to the present version. This research has been supported by NSF Grant No. SES-8410229 to Brown University.



## Abstract

In this paper, we report a generalization of the results of Foley and Guesnerie on the second welfare theorem to economies with arbitrary nonconvex production sets. The nature of marginal cost prices in such economies is clarified through the use of the Clarke tangent cones.





## I. Introduction

It has often been argued, beginning with Hotelling [1939], that even if some firms exhibit increasing returns to scale, optimality demands the establishment of marginal cost prices. A rigorous and general proof of such an assertion was first offered by Guesnerie [1975] but only for economies with certain kinds of nonconvex production sets. Guesnerie's theorem specifically rules out production sets with<sup>1</sup> "inward kinks". It has remained an open question as to whether this restriction on production sets can be dispensed with. In this paper we show that the validity of the second welfare theorem does not depend in any way on the nature of production sets, other than the assumption of free disposal. We also extend our result to economies with public goods and in so doing, generalize a corresponding result of Foley [1970]. This extension is the only result known to us that provides a normative basis for Lindahl pricing in economies with increasing returns to scale in production. As such, it is overdue.

For a proof of his result, Guesnerie modified the, by now classical, argument of Arrow [1951] and Debreu [1954], whereby the aggregate endowment is separated from the sum of the "better than" sets and production sets. By using the fact that the production sets have no inward kinks, Guesnerie could show that the resulting hyperplane furnishes marginal cost prices for each individual set. Unfortunately, we cannot apply this argument in our generalized set-up<sup>2</sup> and need to consider each set

individually rather than their sum. We thus offer a proof different from that of Arrow-Debreu-Guesnerie. It is worth remarking that the structure of our proof is inspired by the work of Guesnerie on second-best-optimality, see Guesnerie [1979]. However, unlike Guesnerie we do not use a theorem of Laurent [1972]. Our work also suggests that the arguments presented here can be used to generalize Theorem 1 of Guesnerie [1979] to the case where the cones of interior displacement are not necessarily convex.

Section II is devoted to our formalization of marginal cost prices and relates the tangent cones used in this paper to those used by Beato [1982], Brown et al. [1983], Cornet [1982] and Guesnerie [1975,1979]. Section III is devoted to the results and their proofs.

## II. Discussion of Tangent Cones and Marginal Rates of Substitution

For concreteness, consider a single input, single output production set as shown in Figure I with the set of technologically efficient points summarized by a "production function"  $f(\cdot)$  which associates with every input level a corresponding level of output. The notion that the marginal rate of substitution at a point is given by the derivative of  $f(\cdot)$  at that point, provided such a derivative exists, needs no reference. However, the notion that these rates at points of non-differentiability such as (a) and (b) are given by the shaded cones in Figure I is almost as old and can be traced at least to Samuelson's Foundations (1947). Already, there Samuelson argued that necessary conditions for



profit maximization would lead a firm to choose production plans at which the prices would lie in the "cone" of the marginal rates of substitution; such a cone being determined by conventional left and right derivatives.

Subsequent emphasis on the convexity assumption of production sets allowed one to ignore production plans such as (b) and (d) and to formalize the marginal rates of substitution as the cone of "subdifferentials" of a concave function, the existence of which did not even require left and right derivatives. A full development of this point of view can be found in Rockafellar [1970].

In a pioneering paper, Guesnerie [1975] began an investigation of nonconvex production sets. He could not use the definition of marginal rates of substitution in the sense of convex analysis simply because the non-convexity of  $Y$  did not allow the use of the separating hyperplane theorems. Instead, Guesnerie followed Dubovickii and Miljurin<sup>3</sup> and considered cones of interior displacement. Heuristically, this simply magnifies and transfers to the origin the "local" shape of the production set at a particular production plan. Thus, the cone of interior displacement at (a) in Figure I is a convex cone generated by the vectors  $ab$  and  $ao$  but with (a) shifted to the origin. For Guesnerie, the marginal rates of substitution at (a) are the normals to the cone of interior displacement at (a), i.e., the shaded cone at (a). As another example, the cone of interior

displacement at (d) is the half-space under the tangent to  $f(\cdot)$  shifted to the origin.<sup>4</sup> In this case, there is a unique normal which coincides with our conventional notion of a marginal rate of substitution in the differentiable case.

The problem with the Dubovickii-Miljurin cone is apparent when we consider the production plan (b). Here the cone of interior displacement is no longer convex as opposed to those at (a), (c) and (d) and it is clear that the normal to such a cone is only the null vector. It is precisely because of this that Guesnerie [1975, 1979] and Beato [1982] rule out production sets with "inward kinks", i.e., points leading to nonconvex cones of interior displacement.

From an economic point of view, it is, of course, clear that the relevant cone of the marginal rates of substitution at (b) is the one shown in Figure 1. It is the set of normals not to the cone of interior displacement but to minus its complement. This simple idea leads us to precisely the Clarke tangent cone which has been recently introduced in the economics literature by Cornet [1982] and used subsequently by Brown et al. [1983]. This cone is always convex and its interior coincides with the cone of interior displacement whenever the set is convex.<sup>5</sup> To bring the circle of ideas back to Samuelson, for the production plan (b) to be a profit-maximizing plan, a necessary condition is that the price vector lies in the normals to the Clarke tangent cone at (b). Indeed, if there is any vector of prices  $p$  such that at a production plan  $y$ , the necessary conditions for profit maximization are satisfied

at  $y$  then  $p$  must belong to the set of normals to the Clarke tangent cone at  $y$  (see Clarke [1983] Corollary to Proposition 2.4.3). Thus, if we define the marginal rates of substitution to be the set of prices which satisfy the necessary conditions for profit maximization then this set is precisely the set of normals to the Clarke tangent cone.

We devote the remainder of this section to a formal presentation of these ideas.

Let  $R^n$  denote  $n$ -dimensional Euclidean space with  $R_+^n$  as its nonnegative orthant and with  $\gg, >, \succ$  as the ordering on vectors. For any set  $A \subseteq R^n$ ,  $Cl A$ ,  $Bdry A$  and  $Int (A)$  will be used to denote its closure, boundary and interior respectively.  $B_\epsilon(y)$  denotes the open ball with center  $y$  and radius  $\epsilon$ .

Definition 1. The cone of interior displacement for  $Y \subseteq R^n$

relative to  $y \in R^n$  is the set

$$K(Y,y) = \{x \in R^n \mid \exists \eta > 0, \epsilon > 0, \text{ such that} \\ \forall \lambda \in [0, \eta], \{y\} + \lambda B_\epsilon(x) \subseteq Y\}.$$

This definition is the one used in Guesnerie [1979] and, under the assumption of free disposal, identical to the one used in Guesnerie [1975]. In order to see that this definition formalizes the fact that the cone of interior displacement magnifies and transfers to the origin the "local" shape of the production set at a particular production plan, consider the sets given by the shaded areas in Figure II and their cones of interior displacement at the origin. In this case  $y = 0$  in Definition 1 and no transfer to the origin is necessary. In Figure IIa,



$K(Y,0)$  is the interior of the set itself. To see that  $x$  is in  $K(Y,0)$ , we have to find an  $\epsilon > 0$  and a control number  $\eta > 0$  such that the  $\epsilon$ -ball around  $x$ ,  $B_\epsilon(x)$ , when multiplied by any non-negative number less than or equal to  $\eta$ , remains in the set. This is clearly so for  $B_\epsilon(x)$  shown in Figure IIa for any choice of  $\eta < \epsilon$ . In Figure IIb,  $x$  is no longer in  $K(Y,0)$ . Here the control number  $\eta$  is crucial in ruling out  $x$  since  $\lambda B_\epsilon(x)$  is in  $Y$  for all  $\lambda > 1$  but no  $\eta > 0$  can be found such that  $\lambda B_\epsilon(x) \subseteq Y$  for all  $\lambda \in [0, \eta]$ . On the other hand, in Figure IIc,  $x$  is in  $K(Y,0)$  but  $B_\epsilon(x)$  is not contained in  $Y$ . However,  $\lambda B_\epsilon(x) \subseteq Y$  for small enough  $\lambda$  and here too  $\eta$  in controlling for the small enough value of  $\lambda$ , plays a determining role.

The Clarke tangent cone is given in the next definition.

Definition 2. The tangent cone for  $Y \subseteq \mathbb{R}^n$ , relative to  $y \in \text{Cl } Y$  is the set

$$T(Y,y) = \{x \in \mathbb{R}^n \mid \text{For any sequence } t^k \rightarrow 0, y^k \rightarrow y \text{ with } y^k \in \text{Cl } Y, \exists \text{ a sequence } x^k \rightarrow x \text{ such that for all large enough } k, y^k + t^k x^k \in \text{Cl } Y\}.$$

Note that Clarke defines his tangent cone only for closed sets while we are extending his definition to an arbitrary set by simply considering its closure. In fact, for  $y \in \text{Cl } Y$ , by (3.3) of Rockafellar [1980],  $T(\text{Cl } Y, y) = T(Y, y)$ . The comparison with  $K(Y, y)$  is facilitated if we consider the interior of  $T(Y, y)$ .

Proposition. For  $Y \subseteq \mathbb{R}^n$  and  $y \in \text{Cl } Y$ ,  $\text{Int } T(Y,y)$  is the set  $\{x \in \mathbb{R}^n \mid \exists \eta > 0, \epsilon > 0, \delta > 0, \text{ such that}$   
 $\forall \lambda \in [0, \eta], \quad \{y'\} + \lambda \text{Cl } B_\epsilon(x) \subseteq Y \text{ for all}$   
 $y' \in (\text{Cl } Y \cap \text{Cl } B_\delta(y))\}$ .

Proof. It is clear that, in the set defined in the Proposition, replacing  $Y$  by  $\text{Cl } Y$  leaves the set unchanged. Theorem 2 of Rockafellar [1979] can now be used to complete the proof.

The reader should now compare the characterization of  $\text{Int } T(Y,y)$  in the Proposition to that of  $K(Y,y)$  in Definition 1. The interior of the Clarke tangent cone simply replaces  $\{y\}$  in the definition of  $K(Y,y)$  by  $\{y'\}$  where  $y'$  is in the intersection of a closed  $\delta$ -ball around  $y$ ,  $\text{Cl } B_\delta(y)$ , with  $\text{Cl } Y$ . To see what difference this makes, consider Figure IIa. In this case  $\text{Int } T(Y,0)$  "shrinks"  $K(Y,0)$  to the area enclosed by the dotted lines. To see why  $x$  does not belong to  $\text{Int } T(Y,0)$ , note that one cannot find any  $\epsilon$ -ball around  $x$  and any  $\delta$ -ball around 0 and any control number  $\eta > 0$  such that  $\lambda \text{Cl } B_\epsilon(x)$  plus the intersection of  $Y$  and  $\text{Cl } B_\delta(0)$  is in  $Y$ . This can also be seen through Definition 2. Choose  $\{y^k\}$  to be a sequence on the lower boundary of  $Y$  and one which tends to  $y = 0$ . There is no way one can find a sequence  $\{x^k\}$  tending to  $x$  such that  $(y^k + t^k x^k)$  is in  $Y$  for large enough  $k$  and for any sequence  $\{t^k\}$  of positive numbers going to zero. This can only be done if  $x$  is in the area enclosed by the dotted lines.

As our verbal discussion makes clear, the primary objects of interest are not the tangent cones but their normals, i.e., their polar cones.

Definition 3. The polar cone of a set  $A \subseteq \mathbb{R}^n$ , is the set

$$A^+ = \{p \in \mathbb{R}^n \mid pa \leq 0 \quad \forall a \in A\}.$$

Let  $N(Y, y) = T(Y, y)^+$ . Since  $A^+ = (Cl A)^+$ ,  $N(Y, y) = (Int T(Y, y))^+$ .

In the remainder of this section we state and prove properties of  $Int T(Y, y)$  and its associated normal cone  $N(Y, y)$  that we shall need for the proofs of our results. Similar results for cones of interior displacement were used by Guesnerie [1979] in his study on second-best optimality.

Lemma 1. Let  $K^1, \dots, K^m$  be non-empty, open convex cones with vertex 0 such that  $\bigcap_i K^i \neq \{\phi\}$ . Then,  $(\bigcap_i K^i)^+ \subseteq \sum_i K^{i+}$ .

Lemma 2. Let  $Y^i \subseteq \mathbb{R}^n$ ,  $i = 1, \dots, m$  and  $y \in \bigcap_i Cl Y^i$ . Then,

$$Int T(\bigcap_i Y^i, y) \supseteq \bigcap_i Int T(Y^i, y).$$

Lemma 3. Let  $\bigcap_i Int T(Y^i, y) \neq \{\phi\}$  and  $\eta \in N(\bigcap_i Y^i, y)$ . Then,

$$\text{there exist } \eta^i \in N(Y^i, y) \text{ such that } \eta = \sum_i \eta^i.$$

Lemma 4. Let  $Y = \prod_i Y^i$  and  $y = (y^1 \times \dots \times y^m) \in Y$ , where  $y^i \in Y^i \subseteq \mathbb{R}^n$ ,  $i = 1, \dots, m$ . Then

$$Int T(Y, y) = \prod_i Int T(Y^i, y^i)$$

$$N(Y, y) = \prod_i N(Y^i, y^i).$$

Lemma 5. Let  $A = \{x \in \mathbb{R}^n \mid f(x) < 0\}$  where  $f$  is a continuous function. If  $f$  is differentiable at  $x^*$  and  $f(x^*) = 0$ , then  $N(A, x^*) = \bigcup_{\lambda > 0} \lambda \text{grad } f(x^*)$ .

Lemma 6. Let  $Y \subseteq \mathbb{R}^n$  and  $y \in \text{Cl } (Y)$ . Then  $\text{Int } T(Y, y) \neq \{\phi\}$  if either

(a)  $Y$  is convex and has an interior

or

(b)  $Y + \mathbb{R}_{++}^n \subseteq Y$

or

(c)  $Y - \mathbb{R}_{++}^n \subseteq Y$ .

Before considering the formal proofs of these lemmata, a heuristic discussion as to their meaning is warranted. This has the further advantage of familiarizing the reader with the tangent and normal cones used in this paper. As regards Lemma 1, let  $K^1$  be the shaded halfspace given by AOB and  $K^2$  the hatched halfspace given by COD in Figure III. If the frontiers are not included,  $K^1$  and  $K^2$  are non-empty, open convex cones with vertex 0 and whose intersection is given by the open cone enclosed by COA. Now the polar cone of COA is given by FOE and it is easy to see that any point in FOE can be obtained by the sum of points in OE and OF which are respectively the polars of  $K^1$  and  $K^2$ . This is what Lemma 1 asserts to be the case in general.

For Lemma 2, let  $Y^1$  and  $Y^2$  be as in Figure IV. Then  $\text{Int } T(Y^1, y)$  is the halfspace below AB and  $\text{Int } T(Y^2, y)$  is the area enclosed by OC and Oy. Thus  $\text{Int } T(Y^1, y) \cap \text{Int } T(Y^2, y)$  is the negative orthant. However,  $Y^1 \cap Y^2$  is given by the set COyE and

$\text{Int } T(Y^1 \cap Y^2, y)$  is the area enclosed by OH and OA. This contains the negative orthant which is being asserted in general in Lemma 2. It can also be checked that  $N(Y^1 \cap Y^2, y)$  is the area enclosed by DOG while  $N(Y^1, y)$  is OD and  $N(Y^2, y)$  is the area enclosed by GOB. It is now easy to see that any point in DOG can be written as the sum of a point in OD and one within GOB which is being asserted, in general, by Lemma 3.

Lemma 4 states that the interior of the tangent cone of a cartesian product of a finite number of sets at some point is the cartesian product of the interiors of the respective tangent cones at the respective projections of that point, i.e., heuristically, the cartesian product operator and the interior of the tangent cone operator commute. Lemma 5 is an assertion that a normal to a set "enclosed" by a differentiable function is the gradient of the function. Lemma 6 provides conditions typically used in economic theory which guarantee non-emptiness of the tangent cone.

We now present the formal proofs of these lemmata and the reader, if so inclined, may move on to the model and results without any loss of continuity.

Proof of Lemma 1. We first show that  $\text{Cl} \left( \bigcap_i K^i \right) \supseteq \left( \bigcap_i K^{i+} \right)^+$ . Pick

$q \in \left( \bigcap_i K^{i+} \right)^+$ . Then,  $q x < 0$  for all  $x \in \bigcap_i K^{i+}$ . Since

$0 \in K^{i+}$  for all  $i$ ,  $q x^i < 0$  for all  $x^i \in K^{i+}$ ,  $i = 1,$



..., m. Hence,  $q \in \bigcap_i K^{i++}$ . Since  $K^i$  is a non-empty

convex cone, by Rockafellar ([1970], p. 121),  $K^{i++} = Cl K^i$ .

Thus,  $q \in \bigcap_i Cl K^i$ . By Rockafellar ([1970], Theorem 6.5)

$$Cl \left( \bigcap_i K^i \right) = \bigcap_i Cl K^i \text{ and thus, } Cl \left( \bigcap_i K^i \right) \supseteq \left( \sum_i K^{i+} \right)^+.$$

By taking polars and again using the fact that  $A^{++} = Cl A$  if  $A$  is a non-empty convex cone, we obtain

$$\left( \bigcap_i K^i \right)^+ \subseteq Cl \left( \sum_i K^{i+} \right). \quad \text{It remains only to be shown that}$$

$\sum_i K^{i+}$  is closed. By Debreu ([1959], p. 23)  $K^{1+} + K^{2+}$  is closed if  $K^{1+}$  and  $K^{2+}$  are positively semi-independent.

Thus, to prove that  $\sum_i K^{i+}$  is closed it suffices to show

that  $K^{i+}$  and  $K^{j+}$  are positively semi-independent for

$i \neq j$ ,  $i, j = 1, \dots, m$ . Towards this end consider  $q^i \in K^{i+}$

and  $q^j \in K^{j+}$  such that  $q^i + q^j = 0$ . We need to show that

$q^i = q^j = 0$ . Since  $K^i$  and  $K^j$  are open and  $K^i \cap K^j \neq \{\emptyset\}$ ,

there exists  $\epsilon > 0$  and  $\bar{x} \neq 0$  such that  $B_\epsilon(\bar{x}) \in K^i \cap K^j$ .

Now  $q^i x < 0$  and  $q^j x < 0$  for all  $x \in B_\epsilon(\bar{x})$ . Since

$q^i = -q^j$ ,  $q^i = q^j = 0$ , and the proof is complete.

Proof of Lemma 2. Let  $x \in \bigcap_i \text{Int } T(Y^i, y)$ . By the Proposition we

can assert that  $\exists \epsilon^i > 0, \delta^i > 0, \lambda^i > 0$  such that  $y^{i'} + t^i x' \in$

$Cl Y^i$  for all  $y^{i'} \in Cl Y^i \cap Cl B_{\delta^i}(y)$ ,

$t^i \in [0, \lambda^i]$ ,  $x' \in \text{Cl } B_{\varepsilon^i}(x)$ . Let  $(\bar{\varepsilon}, \bar{\delta}, \bar{\lambda}) = \text{Min}_i (\varepsilon^i, \delta^i, \lambda^i)$ .

Then, for all  $i$ ,  $y^{i'} + tx' \in \text{Cl } Y^i$  for all

$y^{i'} \in \text{Cl } Y^i \cap \text{Cl } B_{\bar{\delta}}(y)$ ,  $t \in [0, \bar{\lambda}]$ ,  $x' \in \text{Cl } B_{\bar{\varepsilon}}(x)$ .

This implies that, for all  $i$ ,  $y' + tx' \in \text{Cl } Y^i$  for all

$y' \in \bigcap_i \text{Cl } Y^i \cap \text{Cl } B_{\bar{\delta}}(y)$ ,  $t \in [0, \bar{\lambda}]$ ,  $x' \in \text{Cl } B_{\bar{\varepsilon}}(x)$ , i.e.,

$y' + tx' \in \bigcap_i \text{Cl } Y^i$ . Thus,  $x \in \text{Int } T(\bigcap_i Y^i, y)$ .

Proof of Lemma 3. Follows from Lemmata 1 and 2.

Proof of Lemma 4. This is straightforward; the reader may see, for example, the Corollary to Theorem 2.4.5 of Clarke [1983].

Proof of Lemma 5. See Corollary 1 of Theorem 2.4.7 and Definition 2.3.4 of Clarke [1983].

Proof of Lemma 6. If (a) holds we can find  $x \in \mathbb{R}^n$  such that  $x + y \in \text{Int } (Y)$ , and, therefore,  $\exists \varepsilon > 0$  such that  $\text{Cl } B_{\varepsilon}(x) + \text{Cl } B_{\varepsilon}(y) \subseteq Y$ . This implies that  $y' + x' \in Y$  for  $y' \in \text{Cl } Y \cap \text{Cl } B_{\varepsilon}(y)$  and  $x' \in \text{Cl } B_{\varepsilon}(x)$ . Since  $Y$  is convex, we also have  $y' + tx' \in Y$  for all  $t \in [0, 1]$ . Thus, from the Proposition,  $x \in \text{Int } T(Y, y)$ .

If (b) holds, consider  $\epsilon > 0$  and  $x \in R_{++}^n$  such that  $Cl B_\epsilon(x) \in R_{++}^n$ . Then,

$$y' + tx' \in Y \quad \text{for } y' \in Cl Y, \quad t > 0$$

and  $x' \in Cl B_\epsilon(x)$ , i.e.,  $x \in Int T(Y, Y)$ .

If (c) holds, we can show that  $-R_{++}^n \subseteq Int T(Y, Y)$  by the above argument.

### III. The Model and Results

We shall index consumers by  $t$ ,  $t = 1, \dots, T$  each having a consumption set  $X^t \subseteq R_+^n$  and a preference relation  $\succsim_t$ . Let the better-than-set for  $t$  at  $x^t$  be given by  $P^t(x^t) = \{y \in X^t \mid y \succsim_t x^t\}$ . Firms are indexed by  $j$ ,  $j = 1, \dots, F$  each having a production set  $Y^j \subseteq R^n$ . The aggregate endowment is denoted by  $w \in R_{++}^n$ . An economy is thus denoted by  $\mathcal{E} = ((X^t, \succsim_t)_{t=1}^T, (Y^j)_{j=1}^F, w)$  and we shall make the following assumptions on it.

(A.1) For all  $t$  and all  $x^t \in X^t$ ,  
 $x^t \in Cl P^t(x^t)$  and either  $P^t(x^t)$  is convex and has an interior or  $\{x^t\} + R_{++}^n \subseteq P^t(x^t)$ .

(A.2) For all  $j$ ,  $Y^j - R_+^n \subseteq Y^j$ .

We shall need the following economic concepts.

Definition 4.  $((x^{*t}), (y^{*j}))$  is an allocation of  $\mathcal{E}$  if for all  $t = 1, \dots, T$ ,  $x^{*t} \in X^t$ , for all  $j = 1, \dots, F$ ,  
 $y^{*j} \in Y^j$  and  $\sum_t x^{*t} - \sum_j y^{*j} = w$ .

Definition 5. An allocation  $((x^{*t}), (y^{*j}))$  is Pareto optimal if there does not exist any other allocation  $((x^t), (y^j))$  such that  $x^t \in P^t(x^{*t})$  for all  $t$ .

We can now present

Theorem 1. If  $((x^{*t}), (y^{*j}))$  is a Pareto optimal allocation and (A1) and (A2) are satisfied, then there exists  $p^* \in R^n$ ,  $p^* \neq 0$ , such that

- (a)  $-p^* \in N(P^t(x^{*t}), x^{*t})$  for all  $t$ ,
- (b)  $p^* \in N(Y^j, y^{*j})$  for all  $j$ .

$N(Y^j, y^{*j})$  is the set of marginal cost prices for  $j$  at  $y^{*j}$ . For a convex set the normal cone coincides with the cone of normals in the sense of convex analysis (see Clarke [1982], Proposition 2.4.4). Thus, if  $P^t(x^{*t})$  is convex, (a) implies that  $\nexists \bar{x}^t \in P^t(x^{*t})$  with  $p^* \bar{x}^t < p^* x^{*t}$  for all  $t$ . We leave it to the reader to compare Theorem 1 to Theorem 6.4 of Debreu [1959] and Theorem 1 of Guesnerie [1975].

Our proof of Theorem 1 is based on a separating hyperplane argument involving the interior of the tangent cones of the production sets and the better-than-sets. In this respect the fact that the tangent cone is always convex makes it better suited for

our purposes than the cone of interior displacement. It does, however, involve some additional problems but fortunately these can be handled without additional assumptions. Firstly, in general, the interior of the tangent cone is contained in the corresponding cone of interior displacement<sup>7</sup> and may be empty even if the cone of interior displacement is not. By Lemma 6, given (A1) and (A2) this does not occur. Secondly, we cannot use the conventional argument (as in Arrow [1951] or Debreu [1954]) and separate the tangent space of the aggregate production set. This is simply because  $p \in N(Y, y)$  does not necessarily imply that there exist  $y^i \in Y^i$  such

that  $\sum_i y^i = y$  and  $p \in N(Y^i, y^i)$  for all  $i$ . We circumvent this problem by applying the separation argument to production sets and preference sets considered individually.

Before we consider the formalities of the proof of Theorem 1, we clarify some basic notation. Let  $k = n(T+F)$ . We shall use the convention that  $v \in R^k$  can be written as  $v = ((x^t), (y^j))$  where  $x^t$  and  $y^j$  belong to  $R^n$  for all  $t$  and  $j$ . For any  $v$  in  $R^k$ ,  $(v)_{x^t}$  is the projection of the vector  $v$  to the coordinates corresponding to  $x^t$  in  $R^k$ , i.e., the coordinates  $n(t-1)$  to  $nt$ . Similarly,  $(v)_{y^j}$  is the projection of  $v$  to the coordinates corresponding to  $y^j$  in  $R^k$ , i.e., the coordinates  $n(T+j-1)$  to  $n(T+j)$ . Furthermore,  $(v)_{x_\ell^t}$  and  $(v)_{y_\ell^j}$  are respectively the  $n(t-1) + \ell$  and  $n(T+j-1) + \ell$  coordinates where  $\ell$  runs between 1 and



n. For any set  $A$  in  $R^k$ , we shall denote an element of its normal cone at a given point by  $A_\alpha$ . It is important to be clear that  $A_\alpha$  is an element of  $R^k$  and that it would have projections as discussed above.

Proof of Theorem 1.

Let  $k = n(T+F)$  and any  $v \in R^k$  be denoted by  $(x^1, \dots, x^T, y^1, \dots, y^F)$  where  $x^t \in R^n$  and  $y^j \in R^n$  for all  $t = 1, \dots, T$  and all  $j = 1, \dots, F$ . Let  $v^* = ((x^{*t}), (y^{*j}))$  and define the following sets in  $R^k$

$$W_\ell = \{v \in R^k \mid \sum_t x_\ell^t < \sum_j y_\ell^j + w_\ell\} \quad \ell = 1, \dots, n$$

$$V(x^*) = \prod_t P^t(x^{*t}) \times \prod_j Y^j$$

$$M = \bigcap_\ell W_\ell.$$

The basic idea of the proof is to separate the sets  $\text{Int } T(V(x^*), v^*)$  and  $\text{Int } T(M, v^*)$ . Since these sets lie in  $R^k$ , so does the separating hyperplane  $\rho^*$ . We then use the construction of  $M$  to show that  $\rho^*$  is of the form  $(p^*, p^* \dots p^*, -p^*, \dots -p^*)$  where each  $p^*$  is in  $R^n$ . The construction of  $V(x^*)$  then implies that  $-p^*$  is in the normal cone of  $P^t(x^{*t})$  at  $x^{*t}$  and  $p^*$  is in the normal cone of  $Y^j$  at  $y^{*j}$  for all  $t$  and  $j$ . We now spell out these ideas in detail.

Clearly, if  $((x^{*t}), (y^{*j}))$  is Pareto optimal, (A2) implies that  $V(x^*) \cap M = \{\phi\}$ . We now show that  $\text{Int } T(V(x^*), v^*) \cap \text{Int } T(M, v^*) = \{\phi\}$ . Suppose not. Then, there exists

$v \in \text{Int } T(V(x^*), v^*) \cap \text{Int } T(M, v^*)$ . Notice that by (A1),  $v^* \in \text{Cl } V(x^*)$ . By definition of  $M$ ,  $v^* \in M$  so that the tangent cones are well defined. In accordance with our notational convention,  $v$  can be written as  $v = ((x^t), (y^j))$ . By Lemma 4,  $x^t \in \text{Int } T(P^t(x^{*t}), x^{*t})$  for all  $t$  and  $y^j \in \text{Int } T(Y^j, y^{*j})$  for all  $j$ . By the Proposition, there exist positive real numbers  $\eta^t$ ,  $\eta^j$  and  $\eta^m$  such that  $x^{*t} + \lambda^t x^t \in P^t(x^{*t}) \quad \forall \lambda^t \in [0, \eta^t]$ ,  $y^{*j} + \lambda^j y^j \in Y^j \quad \forall \lambda^j \in [0, \eta^j]$  for all  $t$  and  $j$  and  $v^* + \lambda^m v \in M \quad \forall \lambda^m \in [0, \eta^m]$ . Let  $\eta = \text{Min} [\text{Min} (\eta^t), \text{Min} (\eta^j), \eta^m]$ . This implies that for  $\lambda \in [0, \eta]$ ,  $x^{*t} + \lambda x^t \in P^t(x^{*t}) \quad \forall t$ ,  $y^{*j} + \lambda y^j \in Y^j$  for all  $j$  and  $\sum_t (x^{*t} + \lambda x^t) - \sum_j (y^{*j} + \lambda y^j) \leq w$ . Thus,  $v^* + \lambda v \in V(x^*) \cap M$ , contradicting  $V(x^*) \cap M = \{\phi\}$ .

We now verify that  $\text{Int } T(V(x^*), v^*)$  and  $\text{Int } T(M, v^*)$  are non-empty. By Lemma 4,  $\text{Int } T(V(x^*), v^*) = \Pi_t \text{Int } T(P^t(x^{*t}), x^{*t}) \times \Pi_j \text{Int } T(Y^j, y^{*j})$ . Given (A1) and (A2), Lemma 6 implies that  $\text{Int } T(P^t(x^{*t}), x^{*t})$  and  $\text{Int } T(Y^j, y^{*j})$  are non-empty for all  $t$  and  $j$ . Thus,  $\text{Int } T(V(x^*), v^*) \neq \{\phi\}$ . It is easy to check that  $M$  is convex and has a non-empty interior. We can, therefore, apply Lemma 6 to assert that  $\text{Int } T(M, v^*) \neq \{\phi\}$ .

We can now apply the separating hyperplane theorem to assert that there exists  $\rho^* \neq 0$  such that  $\rho^* \in N(M, v^*)$  and  $-\rho^* \in N(V(x^*), v^*)$ . Lemma 3 then implies that there exist vectors  $W_{\ell\alpha} \in N(W_\ell, v^*)$  such that

$$(1) \quad \sum_{\ell} W_{\ell\alpha} = \rho^*.$$

For any  $v \in R^k$  and  $\ell = 1, \dots, n$ , let  $v_\ell = ((x_\ell^t), (y_\ell^j)) \in R^{T+F}$ . Define  $g_\ell(v_\ell) = \sum_t x_\ell^t - \sum_j y_\ell^j - w_\ell$  and

$G_\ell = \{v_\ell \in R^{T+F} \mid g_\ell(v_\ell) < 0\}$ . Since  $\sum_t x^{*t} - \sum_j y^{*j} = w$ , we can appeal to Lemma 5 to assert that  $N(G_\ell, v_\ell^*) = \bigcup_{\lambda > 0} \lambda \text{grad } g_\ell(v_\ell^*)$ . Given the construction of  $g_\ell$ , this clearly implies that any element of  $N(G_\ell, v_\ell^*)$  must be a  $T+F$  dimensional vector of the form  $(p_\ell^*, \dots, p_\ell^* - p_\ell^*, \dots, -p_\ell^*)$  for some  $p_\ell^* \in R$ .

We shall now show that for all  $t$  and  $j$ ,

$$(i) \quad (W_{\ell\alpha})_{x_\ell^t} = p_\ell^* \quad \ell = 1, \dots, n$$

$$(ii) \quad (W_{\ell\alpha})_{y_\ell^j} = -p_\ell^* \quad \ell = 1, \dots, n$$

$$(iii) \quad (W_{\ell\alpha})_{x_q^t} = (W_{\ell\alpha})_{y_q^j} = 0 \quad \ell \neq q.$$

Notice that  $W_\ell$  has been constructed such that its projection on coordinates corresponding to  $v_\ell$  is  $G_\ell$  while its projection on the remaining  $(T+F)(n-1)$  coordinates is  $R$ . We can, therefore, apply Lemma 4 to assert that  $(W_{\ell\alpha})_{v_\ell} \in N(G_\ell, v_\ell^*)$  and, as argued above, it can be written as  $(p_\ell^*, \dots, p_\ell^*, -p_\ell^*, \dots, -p_\ell^*)$ . This establishes (i) and (ii). Since  $N(R, z) = 0$  for any  $z \in R$ , Lemma 4 also yields (iii).

Letting  $p^* = (p_1^*, \dots, p_n^*)$ , we can now assert that  $\sum_\ell W_{\ell\alpha} = (p^*, \dots, p^*, -p^*, \dots, -p^*)$ . By (1)  $\rho^* = (p^*, \dots, p^*, -p^*, \dots, -p^*)$ . Since  $\rho^* \neq 0$ ,  $p^* \neq 0$ . Now,  $-\rho^* \in N(V(x^*), v^*)$  implies, given Lemma 4 and the definition of  $V(x^*)$ , that  $-\rho^* \in N(P^t(x^{*t}), x^{*t})$  for all  $t$  and  $p^* \in N(Y^j, y^{*j})$  for all  $j$ .

Our next result extends Theorem 1 to economies with public goods. Let the first  $n$  commodities be private goods and the next  $m$  be public goods in the sense that their consumption is identical across individuals. An economy with public goods  $\mathcal{E}^G = ((X^t, Y^j)_1^T, (Y^j)_1^F, w)$  is such that for all  $t$ ,  $X^t = (X_\pi^t, X_g^t)$  where  $X_\pi^t \subseteq R_+^n$ ,  $X_g^t \subseteq R_+^m$  are its projections onto the space of private and public goods respectively. We assume that  $X_g^t = X_g$  for all  $t$ ; that  $Y^j \subseteq R^{n+m}$  for all  $j$  and that  $w = (w_\pi, 0)$ ,  $w_\pi \in R_{++}^n$ . Let  $x_{\pi\ell}^t$  and  $x_{g\ell}^t$  refer to the consumption of the  $\ell^{\text{th}}$  private and public good respectively.

Definition 6.  $((x^{*t}), (y^{*j}))$  is an allocation of  $\mathcal{E}^G$  if for all  $t = 1, \dots, T$ ,  $x^{*t} \in X^t$ , for all  $j = 1, \dots, F$ ,  $y^{*j} \in Y^j$ ,  $x_g^{*t} = x_g^*$  for all  $t$  and  $(\sum_t x_{\pi}^{*t}, x_g^*) - \sum_j y^{*j} = w$ . The definition of a Pareto optimal allocation for  $\mathcal{E}^G$  is then identical to the one given in Definition 5. We shall also need an assumption on the desirability of public goods.

$$(A.3) \quad \text{For all } t, \text{ if } \bar{x}_g^t < x_g^t, \text{ then } (x_\pi^t, \bar{x}_g^t) \notin P^t(x^t).$$

We can now present our second result.

Theorem 2. If  $((x_\pi^{*t}, x_g^{*t}), (y^{*j}))$  is a Pareto optimal allocation and (A1) - (A3) are satisfied, then there exist  $p^* = (p_\pi^*, p_g^*) \in R^{n+m}$ ,  $p^* \neq 0$  and, for all  $t$ ,  $p_g^{*t} \in R^m$ , such that

- (a)  $\sum_t p_g^{*t} = p_g^*$
- (b)  $-(p_\pi^*, p_g^{*t}) \in N(P^t(x^{*t}), x^{*t})$  for all  $t$
- (c)  $p^* \in N(Y^j, y^{*j})$  for all  $j$ .

We leave to the reader to compare Theorem 2 to Theorem 1 in Foley [1970].

The proof of Theorem 2 is along the lines of the proof of Theorem 1 with the only difference that additional sets corresponding to public goods have to be introduced in the construction of the set  $M$ . An additional notation that has to be kept in mind is that pertaining to the distinction between public and private goods. Thus, for any commodity bundle  $x^t$ , in  $x_{\pi\ell}^t$   $\ell$  runs from 1 to  $n$  while in  $x_{g\ell}^t$ ,  $\ell$  runs from  $n+1$  to  $n+m$ .

Proof of Theorem 2.

Let  $k = (n+m)(T+F)$  and define the following sets in  $R^k$ .

$$W_{\pi\ell} = \{v \in R^k \mid \sum_t x_{\pi\ell}^t < \sum_j y_{\pi\ell}^j + w_{\pi\ell}\} \quad \ell = 1, \dots, n$$

$$W_{g\ell}^t = \{v \in R^k \mid x_{g\ell}^t < \sum_j y_{g\ell}^j\} \quad \ell = n+1, \dots, n+m$$

$$t = 1, \dots, T$$

$$V(x^*) = \prod_t P^t(x^{*t}) \times \prod_j Y^j$$

$$M = \bigcap_{\ell} W_{\pi\ell} \cap_{\ell, t} W_{g\ell}^t.$$

Clearly, given (A3), if  $((x^{*t}), (y^{*j}))$  is Pareto optimal  $V(x^*) \cap M = \{\phi\}$ . This implies, as in the proof of Theorem 1, that  $\text{Int } T(V(x^*), v^*) \cap \text{Int } T(M, v^*) = \{\phi\}$ . We can also use the argument of the proof of Theorem 1 to show that  $\text{Int } T(V(x^*), v^*)$  and  $\text{Int } T(M, v^*)$  are non-empty.



We can now apply the separating hyperplane theorem to assert that there exists  $\rho^* \neq 0$  such that  $\rho^* \in N(M, v^*)$  and  $-\rho^* \in N(V(x^*), v^*)$ . By Lemma 3, there exist vectors  $W_{\pi l \alpha} \in N(W_{\pi l}, v^*)$ ,  $W_{g l \alpha}^t \in N(W_{g l}^t, v^*)$  such that

$$(2) \quad \sum_l W_{\pi l \alpha} + \sum_{t, l} W_{g l \alpha}^t = \rho^*.$$

As in the proof of Theorem 1, we can use Lemma 4 to show that

$$(W_{\pi l \alpha})_{x_{\pi l}^*} = p_{\pi l}^* \quad \text{for all } t \text{ where } p_{\pi l}^* \in R \text{ and}$$

$$(W_{\pi l \alpha})_{y_{\pi l}^j} = -p_{\pi l}^* \quad \text{for all } j. \text{ Also, } (W_{g l \alpha}^t)_{x_{g l}^t} = p_{g l}^{*t} \text{ for all}$$

$$t \text{ and } (W_{g l \alpha}^t)_{y_{g l}^j} = -p_{g l}^{*t} \text{ for all } j. \text{ Thus (2) yields}$$

$$(\rho^*)_{x^t} = (p_{\pi}^*, p_g^{*t}) \text{ for all } t \text{ and } (\rho^*)_{y^j} = - (p_{\pi}^*, \sum_t p_g^{*t}) \text{ for}$$

$$\text{all } j. \text{ Since } \rho^* \neq 0, \rho^* = (p_{\pi}^*, \sum_t p_g^{*t}) \neq 0. \text{ By Lemma 4,}$$

$$-(p_{\pi}^*, p_g^{*t}) \in N(P^t(x^{*t}), x^{*t}) \text{ for all } t \text{ and } p^* \in N(Y^j, y^{*j})$$

for all  $j$ .

Department of Economics, University of Illinois, 1206 South 6th Street, Champaign, IL 61820.

Department of Economics, Brown University, Providence, RI 02912.

FOOTNOTES

1. This is stated precisely below.
2. For a precise reason, see the discussion preceding the proof of Theorem 1 below.
3. See Guesnerie [1975] for references.
4. Similarly the cone of interior displacement at  $(c)$  is the half-space under the tangent to  $f(\cdot)$  at  $(c)$  shifted to the origin.
5. A precise reference is Laurent ([1972], Theorem 1.3.4) and Rockafeller ([1980], Theorem 1).
6. In the definition of  $T(Y,y)$ , Rockafeller [1979] states "for all  $k$ ". It is clear that he means "for all large enough  $k$ ".
7. This follows, for example, from Proposition 3.4 (b) of Cornet [1982] taking account of the fact that  $I_0(y)$  and  $I_1(y)$  in that paper correspond to  $\text{Int } T(Y,y)$  and  $K(Y,y)$  of this paper.

REFERENCES

- Arrow, K. J., "An Extension of the Basic Theorems of Classical Welfare Economics," Proceedings of the Second Berkeley Symposium (Berkeley, CA: University of California Press, 1951).
- Beato, P., "The Existence of Marginal Cost Pricing Equilibria with Increasing Returns," Quarterly Journal of Economics, XCVI (1982), 669-88.
- Brown, D. J., G. M. Heal, M. Ali Khan and R. Vohra, "On a General Existence Theorem for Marginal Cost Pricing Equilibria," Brown University Working Paper Number 83-15, 1983, Journal of Economic Theory (forthcoming).
- Clarke, F. H., Optimization and Nonsmooth Analysis, (New York: John Wiley, 1983).
- Cornet, B., "Existence of Equilibria in Economies with Increasing Returns," Berkeley Paper Number I8-311, 1982.
- \_\_\_\_\_, "Regular Properties of Open Tangent Cones," CORE Discussion Paper Number 8425, 1984.
- Debreu, G., "Valuation Equilibrium and Pareto Optimum," Proceedings of the National Academy of Sciences, XC (1954), 588-92.
- \_\_\_\_\_, Theory of Value, (New York: Wiley, 1959).
- Guesnerie, R., "Pareto Optimality in Non-Convex Economies," Econometrica, XLIII (1975), 1-29.

- \_\_\_\_\_, "General Statements on Second-Best Pareto Optimality," Journal of Mathematical Economics, VI (1979), 169-94.
- Foley, D. K., "Lindahl's Solution and the Core of an Economy with Public Goods," Econometrica, XXXVIII (1970), 66-72.
- Hotelling, H., "The Relation of Prices to Marginal Costs in an Optimum System," Econometrica, VII (1939), 151-55.
- Laurent, P., Approximation of Optimization, (Paris: Hermann 1972).
- Rockafellar, R. T., Convex Analysis, (Princeton, NJ: Princeton University Press, 1970).
- \_\_\_\_\_, "Clarke's Tangent Cones and the Boundary of Closed Sets in  $R^n$ ," Nonlinear Analysis, III (1979), 145-54.
- \_\_\_\_\_, "Generalized Directional Derivatives and Subgradients of Nonconvex Functions," Canadian Journal of Mathematics, XXXII (1980), 257-280.
- Samuelson, P. A., Foundations of Economic Analysis (Cambridge, MA: Harvard University Press, 1947).

FIGURE I

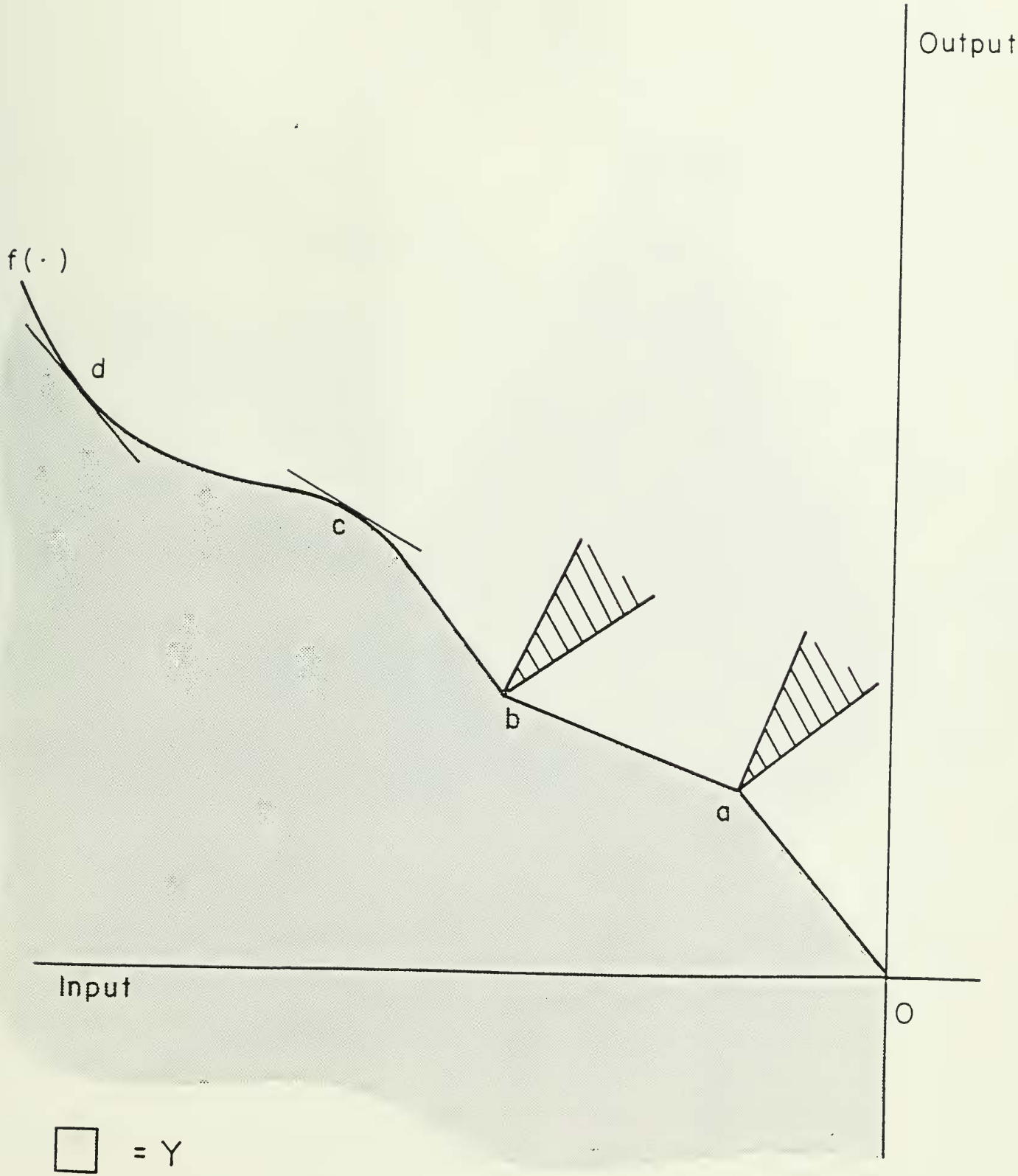
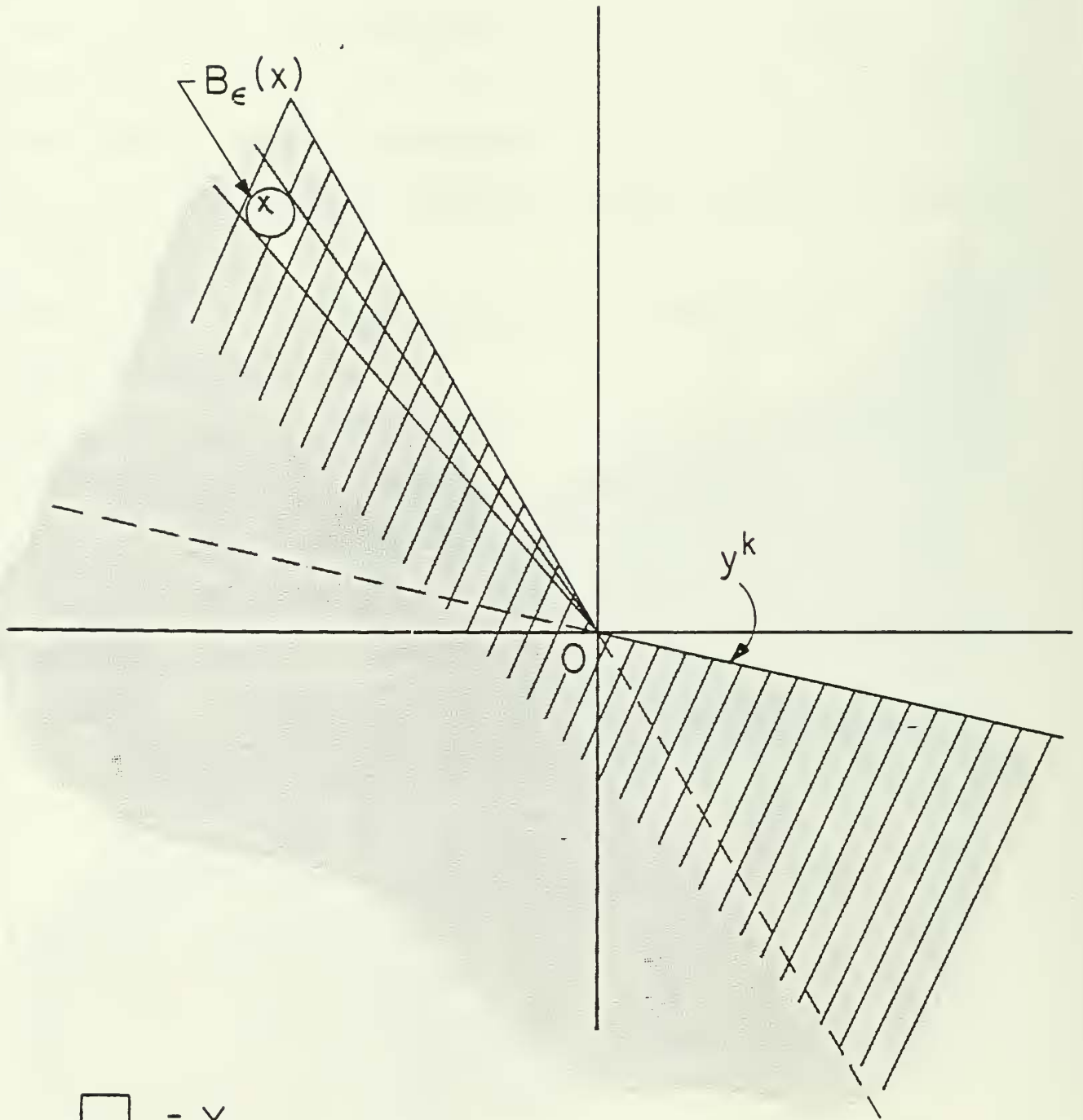



FIGURE II a



$\square = Y$

$\square = K(Y, O)$

FIGURE II b

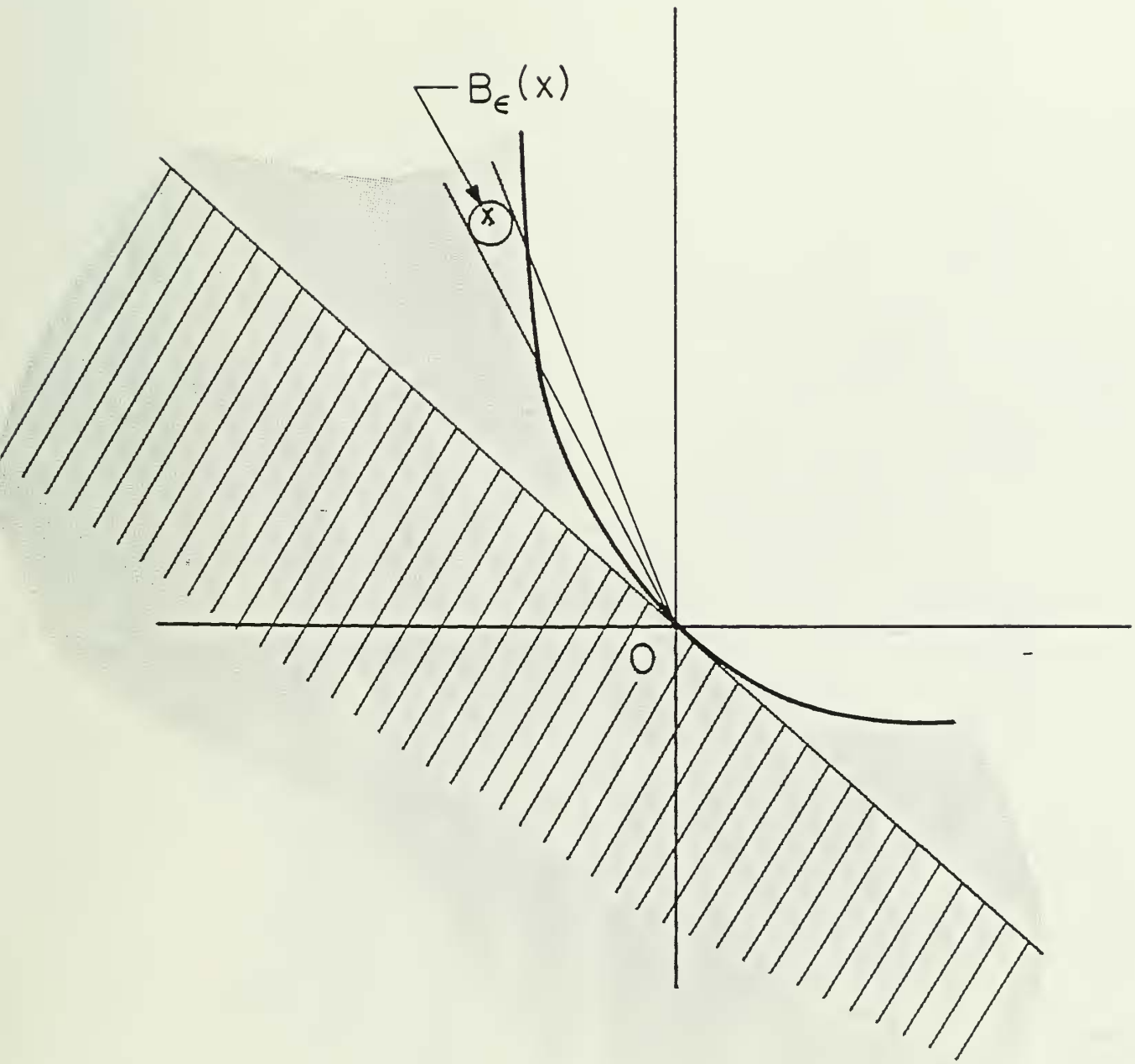

- $\square = Y$
- $\square = K(Y, O)$

FIGURE II c

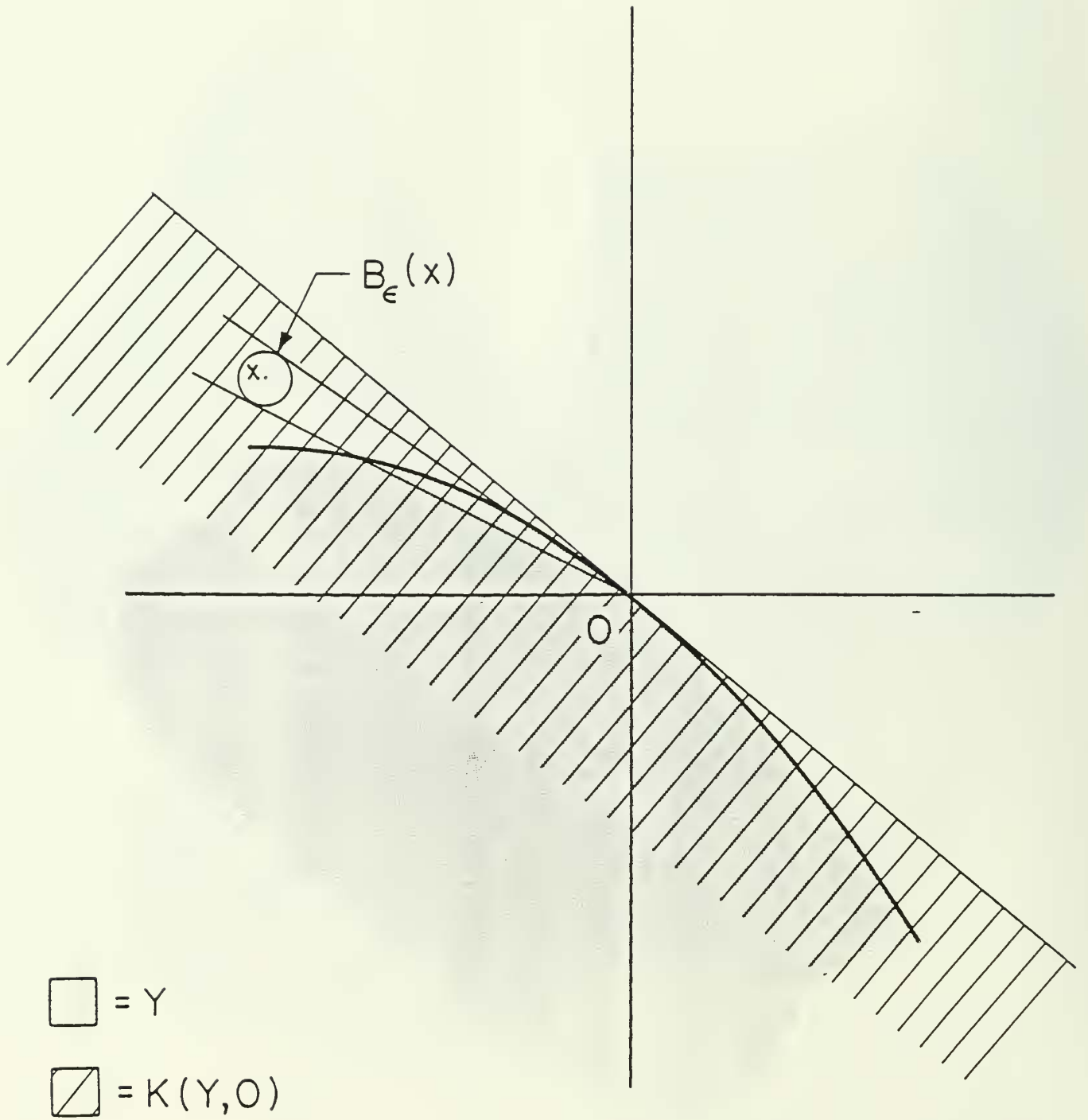
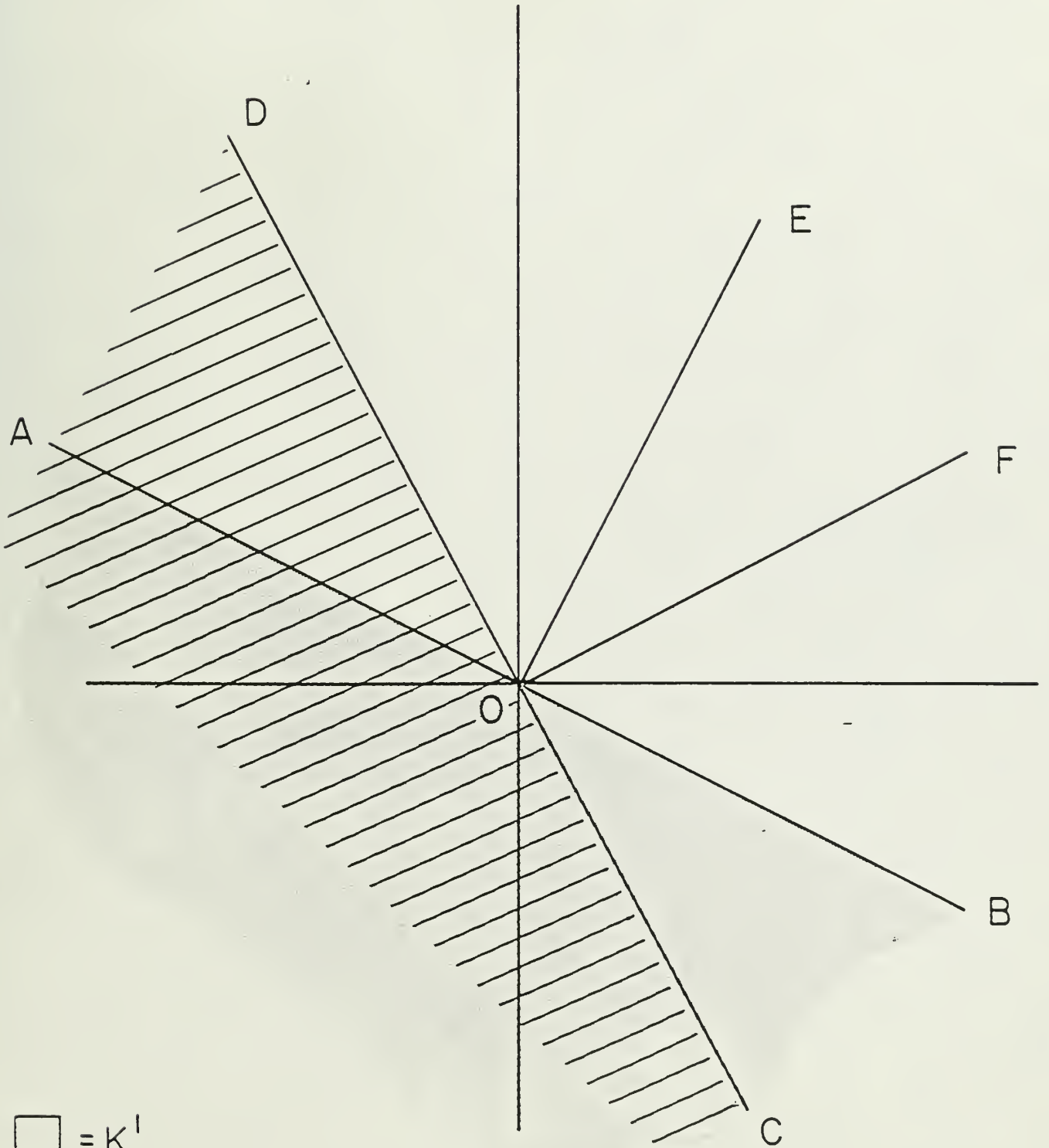
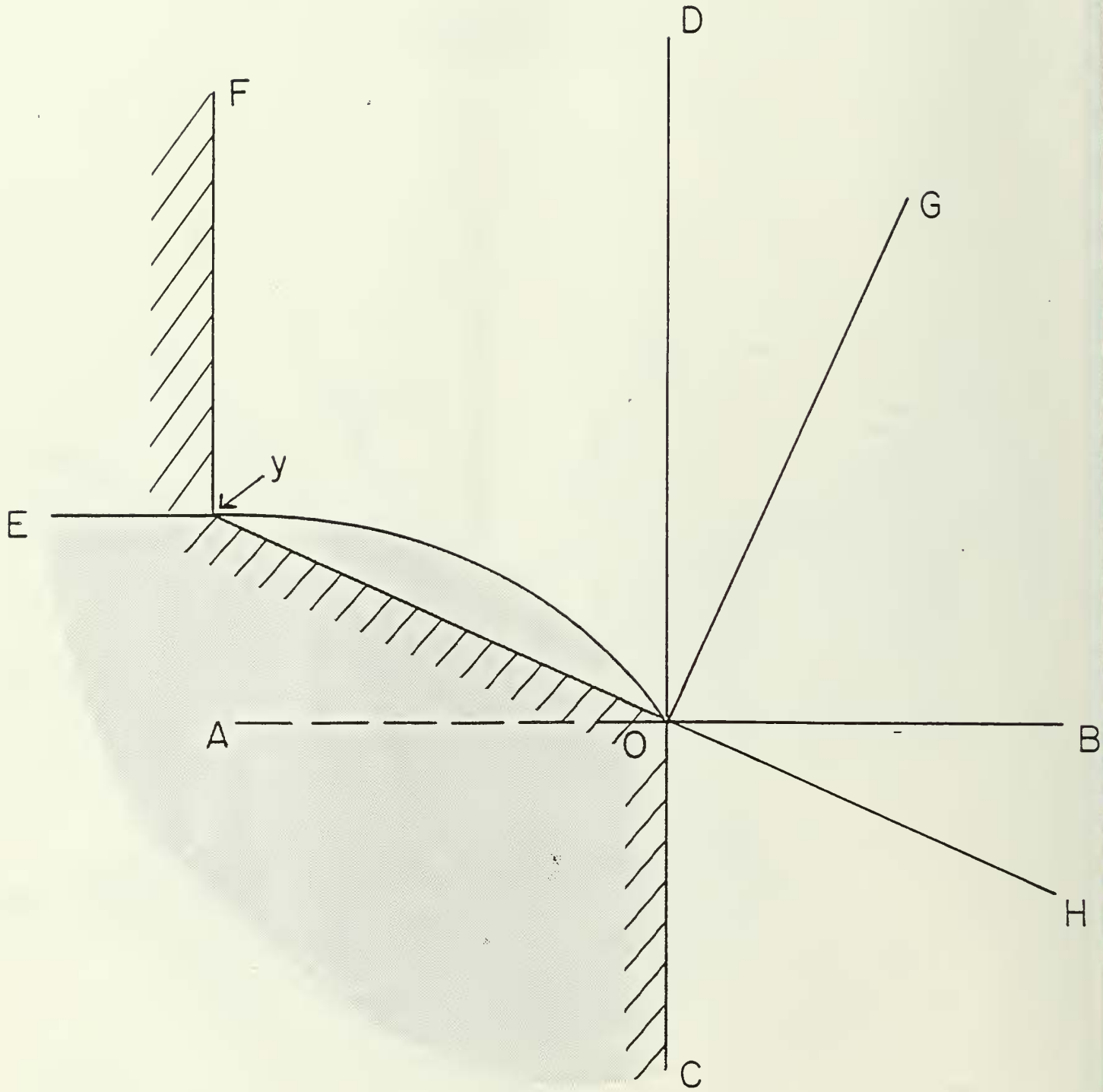



FIGURE III



$\square$  =  $K^1$   
 $\square$  =  $K^2$

FIGURE IV



 =  $Y^1$   
 =  $Y^2$







HECKMAN  
BINDERY INC.



**JUN 95**

Bound-To-Pleas<sup>®</sup> N. MANCHESTER,  
INDIANA 46962



UNIVERSITY OF ILLINOIS-URBANA



3 0112 005699951