

 Open access • Journal Article • DOI:10.1109/TPEL.2014.2332181

An Improved Droop Control Strategy for Reactive Power Sharing in Islanded Microgrid — [Source link](#)

Hua Han, Yao Liu, Yao Sun, Mei Su ...+1 more authors

Institutions: Central South University, Aalborg University

Published on: 01 Jun 2015 - IEEE Transactions on Power Electronics (IEEE)

Topics: Voltage droop, Voltage optimisation, Microgrid, Voltage regulation and AC power

Related papers:

- [Hierarchical control of droop-controlled DC and AC microgrids — a general approach towards standardization](#)
- [An Enhanced Microgrid Load Demand Sharing Strategy](#)
- [Design and Analysis of the Droop Control Method for Parallel Inverters Considering the Impact of the Complex Impedance on the Power Sharing](#)
- [Accurate Reactive Power Sharing in an Islanded Microgrid Using Adaptive Virtual Impedances](#)
- [Robust Droop Controller for Accurate Proportional Load Sharing Among Inverters Operated in Parallel](#)

Share this paper:    

View more about this paper here: <https://typeset.io/papers/an-improved-droop-control-strategy-for-reactive-power-3njc1h8j4>



AALBORG UNIVERSITY
DENMARK

Aalborg Universitet

An Improved Droop Control Strategy for Reactive Power Sharing in Islanded Microgrid

Han, Hua; Liu, Yao; Sun, Yao; Su, Mei; Guerrero, Josep M.

Published in:
I E E E Transactions on Power Electronics

DOI (link to publication from Publisher):
[10.1109/TPEL.2014.2332181](https://doi.org/10.1109/TPEL.2014.2332181)

Publication date:
2015

Document Version
Early version, also known as pre-print

[Link to publication from Aalborg University](#)

Citation for published version (APA):
Han, H., Liu, Y., Sun, Y., Su, M., & Guerrero, J. M. (2015). An Improved Droop Control Strategy for Reactive Power Sharing in Islanded Microgrid. *I E E E Transactions on Power Electronics*, 30(6), 3133 - 3141 .
<https://doi.org/10.1109/TPEL.2014.2332181>

General rights

Copyright and moral rights for the publications made accessible in the public portal are retained by the authors and/or other copyright owners and it is a condition of accessing publications that users recognise and abide by the legal requirements associated with these rights.

- Users may download and print one copy of any publication from the public portal for the purpose of private study or research.
- You may not further distribute the material or use it for any profit-making activity or commercial gain
- You may freely distribute the URL identifying the publication in the public portal -

Take down policy

If you believe that this document breaches copyright please contact us at vbn@aub.aau.dk providing details, and we will remove access to the work immediately and investigate your claim.

An Improved Droop Control Strategy for Reactive Power Sharing in Islanded Microgrid

Hua Han, Yao Liu, Yao Sun, Mei Su, and Josep M. Guerrero

School of Information Science and Engineering, Central South University, Changsha 410083,
Hunan Province, China

J. M. Guerrero is with the Department of Energy Technology, Aalborg University, 9220 Aalborg East, Denmark
(Tel: +45 2037 8262; Fax: +45 9815 1411; e-mail: joz@et.aau.dk).

Abstract – For microgrid in islanded operation, due to the effects of mismatched line impedance, the reactive power could not be shared accurately with the conventional droop method. To improve the reactive power sharing accuracy, this paper proposes an improved droop control method. The proposed method mainly includes two important operations: error reduction operation and voltage recovery operation. The sharing accuracy is improved by the sharing error reduction operation, which is activated by the low-bandwidth synchronization signals. However, the error reduction operation will result in a decrease in output voltage amplitude. Therefore, the voltage recovery operation is proposed to compensate the decrease. The needed communication in this method is very simple, and the plug-and-play is reserved. Simulations and experimental results show that the improved droop controller can share load active and reactive power, improve the power quality of the microgrid, and also have a good dynamic performance.

KEY WORDS: Microgrid; droop control; reactive power sharing; low-bandwidth synchronization signals; voltage recovery mechanism

I INTRODUCTION

The application of distributed generation (DG) has been increasing rapidly in the past decades. Compared to the conventional centralized power generation, DG units have advantages of less pollution, higher efficiency of energy utilization, flexible installation location, and less power transmission losses. Most of the DG units are connected to the grid via power electronic converters, which introduces system resonance, protection interference, etc. To overcome these problems a microgrid concept was first proposed in the US by the consortium for electrical reliability technology solutions [1]. Compared to using a single DG unit, microgrid could offer superior power management within the distribution networks. Moreover, the microgrid can operate both in

grid-connected mode and islanding mode and benefit both the utility and customers in economy [2-7].

In islanding mode, the load power in the microgrid should be properly shared by multiple DG units. Usually, the droop control method which mimics the behavior of a synchronous generator in traditional power system is adopted, which does not need the use of critical communications [8-14, 21-22]. The active power sharing is always achieved by the droop control method easily. However, due to effects of mismatched feeder impedance between the DGs and loads, the reactive power will not be shared accurately. In extreme situations, it can even result in severe circulating reactive power and stability problems [11].

To overcome the reactive power sharing issue, a few improved methods have been proposed. Specifically, there are mainly three approaches to address the effect of the interconnecting line impedance on droop-based control. The first approach is to introduce the virtual output impedance by modifying the output voltage reference based on output current feedback [11,13-14,23]. This method can reduce the reactive power sharing error by reducing the relative error of the output impedances. However, the introduction of the virtual impedance may lead to degradation of the system voltage quality. The second approach is based on signal injection technique. In [15], a certain harmonic signal containing reactive power information is injected into the output voltage reference of each DG unit, and the output reactive power is regulated according to the harmonic power to improve the accuracy of the reactive power sharing. However, this method results in output voltage distortion. In [16], in order to reduce the reactive power sharing errors, the method injects some small disturbance signal containing

reactive power information into the frequency reference of each DG unit. By using the active power error before and after the injecting signal, this method can eliminate the reactive power error. However, this method is a classic event-triggered control and its stability is not easy to be guaranteed. Additionally, the third approach is usually based on constructed and compensated method. In [17], the method constructs an integral control concerning the common bus voltage to ensure the reactive power sharing. However, in practical situation, the common bus voltage information is difficult to get.

In this paper, a new reactive power sharing method is proposed. The method improves the reactive power sharing by changing the voltage bias on the basis of the conventional droop control, which is activated by a sequence of synchronization event through the low bandwidth communication network. It is a cost-effective and practical an approach since only a low bandwidth communication network is required. Simulation and experimental results are provided to verify the effectiveness and feasibility of the proposed reactive power sharing method.

The paper is organized as follows. Section II gives the system configuration and the reactive power sharing errors analysis with conventional droop control. Section III proposes an improved reactive power sharing control strategy, and the convergence and robustness is analyzed. Simulation and experimental results are given in Section IV. Section V gives the conclusion.

II ANALYSIS OF THE CONVENTIONAL DROOP CONTROL METHOD

A. Configuration and operation of AC Microgrid

A classic configuration of a microgrid which consists of multiple distributed generation (DG) units and dispersed loads is shown in Fig.1. The microgrid is connected to the utility through a static transfer switch at the PCC. Each DG unit is connected to the microgrid through power electronic converter and its respective feeder.

This paper aims to solving the fundamental active and reactive power sharing in islanding mode, and the power sharing issues on harmonic currents is out of the scope of the paper.

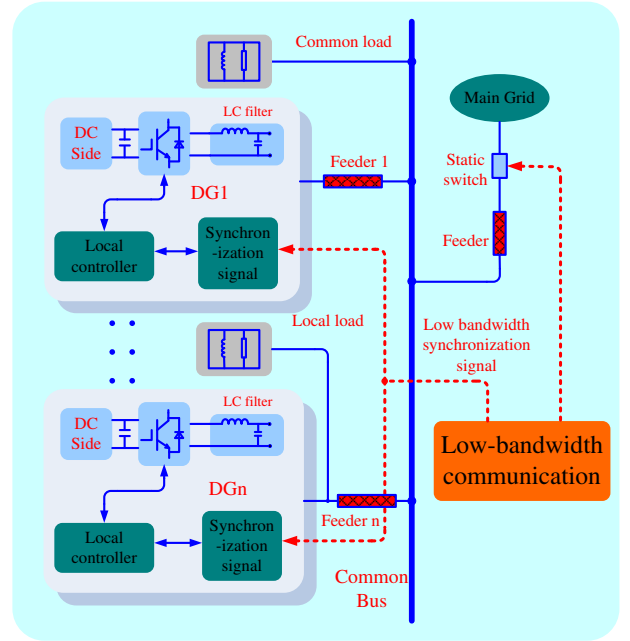

Fig.1. Illustration of the AC microgrid configuration.

B. The conventional Droop Control

Fig. 2 shows the equivalent model of a DG unit, which is interfaced to the common bus of the AC microgrid through a power inverter with a output LCL filter. As shown in Fig.2, $E_i \angle \delta_i$ is the voltage across the filter capacitor, $V_{pcc} \angle 0^\circ$ is the common AC bus voltage. Compared with the inductance of the LCL filter, the line resistance can be ignored. Then the impedance between inverter and the common bus can be described as X_i ($X_i = \omega L_i$).

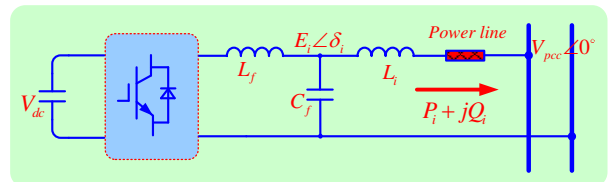

Fig.2 Model of a DG unit.

According to the equivalent circuit in Fig. 2, the inverter output apparent power is S_i , and it can be given by

$$S_i = P_i + jQ_i = \frac{E_i V_{pcc}}{X_i} \sin \delta_i + j \left[\frac{E_i V_{pcc} \cos \delta_i - V_{pcc}^2}{X_i} \right] \quad (1)$$

From equation (1), the output active and reactive power of the DG units are shown as

$$\begin{cases} P_i = \frac{E_i V_{pcc}}{X_i} \sin \delta_i \\ Q_i = \frac{E_i V_{pcc} \cos \delta_i - V_{pcc}^2}{X_i} \end{cases} \quad (2)$$

Usually, the phase shift angle δ_i is small. Therefore, the real power P_i and reactive power Q_i of each DG can be regulated by δ_i and the output voltage amplitude E_i , respectively [24]. Then the conventional droop control is given by

$$\begin{cases} \omega_i = \omega^* - m_i \cdot \overline{P}_i \\ E_i = E^* - n_i \cdot \overline{Q}_i \end{cases} \quad (3)$$

Where ω^* and E^* are the nominal values of DG angular frequency and DG output voltage amplitude, m_i and n_i are the active and reactive droop slopes, respectively. \overline{P}_i and \overline{Q}_i are the measured averaged real and reactive power values through a low pass filter, respectively.

C. Reactive Power Sharing Errors Analysis

For simplicity, a simplified microgrid with two DG units is considered in this section.

According to equations (2) and (3), the reactive power of the i -th DG unit is obtained

$$Q_i = \frac{V_{pcc}(E_i^* \cos \delta_i - V_{pcc})}{X_i + V_{pcc} n_i \cos \delta_i} \quad (4)$$

Assume the i -th and j -th DG unit are working in parallel with the same nominal capacity and droop slope. Note that shift angle δ_i is usually vary small ($\sin \delta_i \approx \delta_i$, $\cos \delta_i \approx 1$), then the reactive power sharing relative error with respect to Q_i can be expressed as follows

$$\Delta Q_{err} = \frac{Q_i - Q_j}{Q_i} \approx \frac{X_j - X_i}{X_j + V_{pcc} n_j} \quad (5)$$

It is shown that, the reactive power sharing relative error is related to some factors, which include the impedance X_j , the impedance difference ($X_j - X_i$), the voltage amplitude V_{pcc} of PCC and the droop slope n_j . According to (5), there are two main approaches to improve the reactive power sharing accuracy: Increasing impedance X_j and the droop gain n_j . Usually, increasing impedance is achieved by the virtual impedance [11,13-14], which requires a high-bandwidth control for inverters. Increasing the droop gain n_j is a simpler way to reduce the sharing error. However, it may degrade the quality of the microgrid bus voltage, and even affects the stability of

the microgrid system [18-20].

III PROPOSED REACTIVE POWER SHARING ERROR COMPENSATION METHOD

A. Proposed Droop Controller

The proposed droop control method is given as follows:

$$\omega_i = \omega^* - m_i P_i \quad (6)$$

$$E_i(t) = E^* - n_i Q_i(t) - \sum_{n=1}^{k-1} K_i Q_i^n + \sum_{n=1}^k G^n \Delta E \quad (7)$$

where k denotes the times of synchronization event until time t . According to (7), the control is a hybrid system with continuous and discrete traits. In the digital implementation of the proposed method, the continuous variables $E_i(t)$ and $Q_i(t)$ are discretized with sampling period T_s , and T_s is greatly less than the time interval between two consecutive synchronization events. Therefore, the droop equation (7) at the k -th synchronization interval could be expressed as

$$E_i^k = E^* - n_i Q_i^k - \sum_{n=1}^{k-1} K_i Q_i^n + \sum_{n=1}^k G^n \Delta E \quad (8)$$

where ω^* and E^* are the values of DG angular frequency and output voltage amplitude at no-load condition; m_i and n_i are the droop gain of frequency and voltage of DG- i unit; G^n is the voltage recovery operation signal at the n -th synchronization interval, G^n has two possible values: 1 or 0. If $G^n=1$, it means the voltage recovery operation is performed. Q_i^n represents the output reactive power of DG- i unit at the n -th synchronization interval. K_i is a compensation coefficient for the DG- i unit, ΔE is a constant value for voltage recovery. For simplicity of description, the third term of (8) is referred to the sharing error reduction operation, and the last term is called the voltage recovery operation. For simplicity, the output voltage for the DG- i unit in (8) is written as follows in iterative method.

$$E_i^k = E_i^{k-1} + n_i(Q_i^k - Q_i^{k-1}) - K_i Q_i^{k-1} + G^k \Delta E \quad (9)$$

Therefore, in its implementation, only E_i^{k-1} and Q_i^{k-1} should be stored in DSP. To better understand

the proposed method, a specific example is given. If there are two DG units with the same capacity working in parallel, and only the conventional droop is used. There will be exists some reactive power sharing error due to some factors. If the sharing error reduction operation for each DG unit is performed at the time, the resulting reactive power sharing error will decrease. The principle behind the sharing error reduction operation can be understood with the aid of Fig. 3. If the aforementioned operation is repeated with time, the reactive power sharing error will converge. However, the associated operations will result in a decrease in PCC voltage. To cope with the problem, the voltage recovery operation will be performed. That is to say if the output voltage of one DG unit is less than its allowed lower limit, then the DG unit will trigger the voltage recovery operation until its output voltage is restored to rating value. The output voltage of all the DG units will be added an identical value ΔE to increase the PCC voltage. The idea for the voltage recovery operation can be comprehended by the aid of Fig. 4.

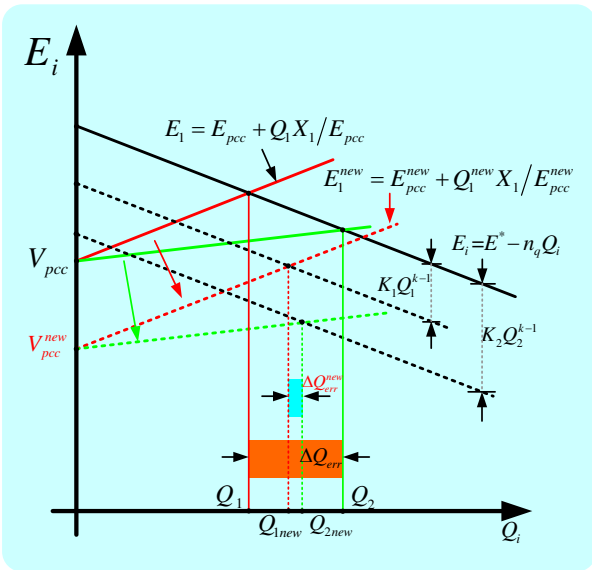

Fig. 3 Schematic diagram of the shaing error reduction operation

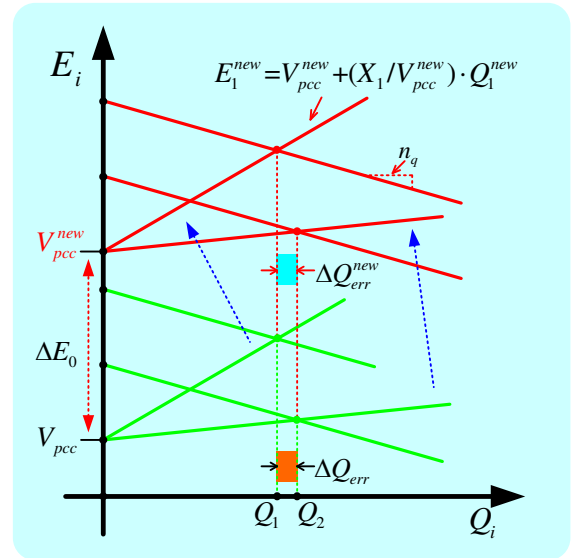

Fig. 4 Schematic diagram of voltage recovery mechanism

B. Communication setup

A DG unit can communicate with other DG units by RS232 serial communication. Each DG unit has the opportunity to trigger a synchronization event on the condition that the time interval between two consecutive synchronization events is greater than a permissible minimum value and the output voltage of each DG unit is in the reasonable range. If the output voltage of one DG unit is less than its allowed lower limit, it will ask for having the priority to trigger a synchronization event at once. Until the constraint which two consecutive synchronization events is greater than a permissible minimum value is satisfied, the DG unit with the priority will trigger a synchronization event, and in this event, the command for voltage recovery operation will be sent to other DG units. If the communication fails (the time interval between two consecutive synchronization events is greater than a permissible maximum value), all the error reduction operations and voltage recovery operations should be disabled and the proposed control method is revert back to the conventional one.

According to the analysis above, such a microgrid system only needs a low-bandwidth communication. And it is robust to the delay of communication. To illustrate this point, the control timing diagram shown in Fig.5 is used. The sharing error operation and the voltage recovery operation are performed in update interval. Sampling operation occurs in sampling

interval. There is a time interval τ , which is long enough to guarantee the system having been in steady state. It is obvious that proposed method is robust to the time delay because all the necessary operations only need to be completed in an interval, not a critical point.

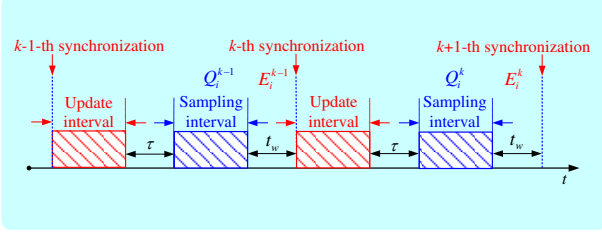

Fig. 5 Control timing diagram of one DG with the two consecutive synchronization events.

C. Convergence Analysis

In this subsection, the convergence of the proposed method will be proved. Without loss of generality, the sharing reactive power error between DG- i and DG- j with the same capacity will be analyzed. According to (8), the reactive droop equation for DG- j can be expressed as

$$E_j^k = E^* - n_j Q_j^k - \sum_{n=1}^{k-1} K_j Q_j^n + \sum_{n=1}^k G^n \Delta E \quad (10)$$

Subtracting (10) from (8), then

$$\Delta E_{ij}^k = -n \Delta Q_{ij}^k - \sum_{n=1}^{k-1} K \Delta Q_{ij}^n \quad (11)$$

where $n=n_j=n_i$, $K=K_j=K_i$, and ΔE_{ij}^k is the voltage magnitude derivation of DG i and j in the k -th control period; ΔQ_{ij}^k is the reactive power sharing errors.

Similarly, we can get equation (11) in the $k+1$ -th interval.

$$\Delta E_{ij}^{k+1} = -n \Delta Q_{ij}^{k+1} - \sum_{n=1}^k K \Delta Q_{ij}^n \quad (12)$$

Combining (11) and (12), it yields:

$$\Delta E_{ij}^{k+1} - \Delta E_{ij}^k = -n \Delta Q_{ij}^{k+1} + n \Delta Q_{ij}^k - K \Delta Q_{ij}^k \quad (13)$$

According to the feeder characteristic, as shown in (2), the following expressions can be obtained.

$$\Delta E_{ij}^{k+1} = \frac{1}{V_{pcc}^{k+1}} (Q_i^{k+1} X_i - Q_j^{k+1} X_j) \quad (14)$$

$$\Delta E_{ij}^k = \frac{1}{V_{pcc}^k} (Q_i^k X_i - Q_j^k X_j) \quad (15)$$

Assume the PCC voltage value satisfy the following

$$V_{pcc}^{k+1} \approx V_{pcc}^k \approx V \square 1 \quad (16)$$

Subtracting (13) from (14), it yields

$$\Delta E_{ij}^{k+1} - \Delta E_{ij}^k = \frac{X_j}{V} (\Delta Q_{ij}^{k+1} - \Delta Q_{ij}^k) + \frac{\Delta X}{V} (Q_i^{k+1} - Q_i^k) \quad (17)$$

where $\Delta X = X_i - X_j$.

Combining the expression (13) and (17), then

$$\Delta Q_{ij}^{k+1} = r \Delta Q_{ij}^k - \frac{\Delta X}{V(n+X_j/V)} [Q_i^{k+1} - Q_i^k] \quad (18)$$

where $r = \frac{n+X_j/V-K}{n+X_j/V} < 1$. According to the contraction

mapping theorem, if $|r| < 1$ and $\Delta X = 0$, then reactive power sharing error will converge to zero. However, $\Delta X \neq 0$, we should also consider the effect of the second term of (18).

According to the feeder characteristic, as shown in (1), we have

$$Q_i^{k+1} - Q_i^k = \frac{(E_i^{k+1} - E_i^k)V}{X_i} \quad (19)$$

Because of the voltage recovery mechanism, we can ensure $E_{\min} \leq E_i^k \leq E_{\max}$ for all k .

$$|Q_i^{k+1} - Q_i^k| \leq (E_{\max} - E_{\min}) \frac{V}{X_i} \quad (20)$$

Therefore, the second term of (18) is bounded. According to analysis above, it can be concluded that the reactive power sharing error is also bounded.

IV SIMULATION AND EXPERIMENTS RESULTS

A. Simulation Results

The proposed improved reactive power sharing strategy has been verified in MATLAB/Simulink and experimentally. In the simulations and experiments, a microgrid with two DG systems, as shown in Fig. 1, is employed. The associated parameters for Power stage and control of the DG unit are listed in Table I. Also in the simulations and experiments, in order to facilitate the observation of the reactive power sharing, the two DG units are designed with same power rating and different line impedances. The detailed configuration

of the single DG unit is depicted in Fig. 6, where an LCL filter is placed between the IGBT bridge output and the DG feeder. The DG line current and filter capacitor voltage are measured to calculate the real and reactive powers. In addition, the commonly used double closed-loop control is employed to track the reference voltage [5], [7], [12].

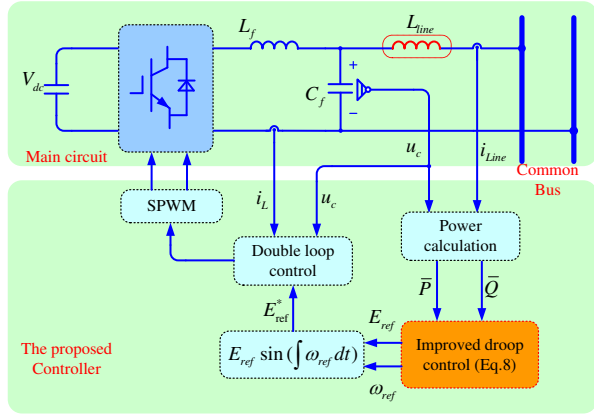

Fig. 6 Configuration of one single-phase DG unit.

Tab. I

Associated parameters for Power stage and control of the DG unit

Parameters	Values	Parameters	Values
u_{rate} (V)	220	k_{pu}	0.05
L_f (mH)	1.5e-3	k_{pi}	50
r_f (Ω)	0.25	K_{ip}	0.2
C_f (μ F)	20	w_c (rad/s)	31.4
L_{Line1} (mH)	0.6e-3	m (rad/sec \cdot w)	5e-5
L_{Line2} (mH)	0.3e-3	n (v/var)	5e-3
f_s (KHz)	12.8	Ke (v/var)	0.001
f_{rate} (Hz)	50	ΔE_0 (V)	5
T_s (s)	1/12.8e3	T_{syn} (min) (s)	0.1

1) Case 1: power sharing accuracy improvement

Two identical DG units operate in parallel with the proposed voltage droop control. Fig.7 illustrates the reactive power sharing performance of the two DGs. Before $t=0.5s$, the sharing error reduction operation and voltage recovery operation are disabled, which is equivalent to the conventional droop control being in effect. There exists an obvious reactive power sharing error due to the unequal voltage drops on the feeders. After $t=0.5s$, the reactive power sharing error reduction operation is performed, it is clear that the reactive power sharing error converges to zero

gradually. After $t=1s$, the voltage recovery operation is performed. It can be observed that the output reactive power increases but the reactive power sharing performance does not degrade. Fig.8 shows the corresponding output voltages. It can be observed that the output voltages decrease during the sharing error reduction operation, while the voltage recovery operation ensures that DG output voltage amplitude can restore back nearby to the rated value. The whole process of adjustment can be done steadily in a relatively short period of time. Fig.9 illustrates active power sharing performance of the two DG units. It is obvious that the proposed improved reactive power sharing strategy does not affect active power sharing performance.

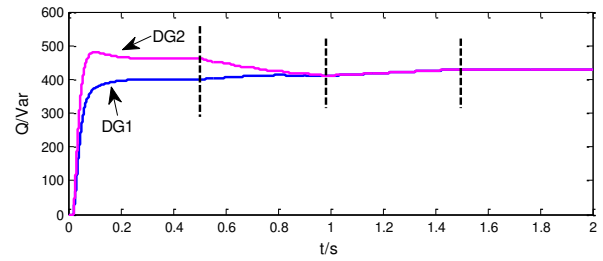

Fig. 7 Output reactive powers of two inverters with the improved droop control.

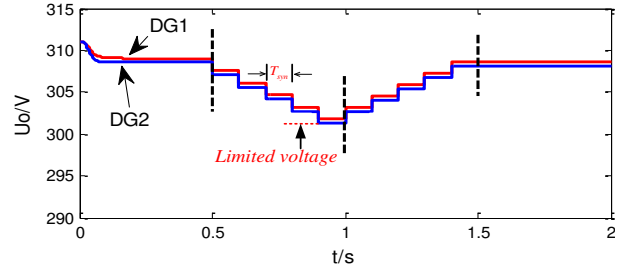

Fig. 8 Output voltage amplitude of two inverters with the improved droop control.

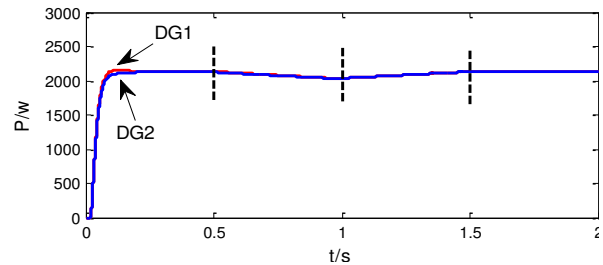

Fig. 9 Output active powers of two inverters with the improved droop control.

2) Case 2: Effect of the communication delay

To test the sensitivity of the proposed improved droop control to the synchronized signal accuracy, a 0.02s delay is intentionally added to the signal

received by DG1 unit at $t=0.5s$ as shown in Fig.11, and the simulation results are shown in Fig.10, 11 and 12. Compared to the case 1 in Fig.7 and 9, a small disturbance appears in both the reactive and active power, while the voltage recovery operations are still able to ensure that the DG unit can deliver the expected reactive power. After $t=2.0s$, the active and reactive power sharing errors are almost zero. Therefore, the proposed reactive power sharing strategy is not sensitive to the communication delay. Then it is illustrated that it is robust to some small communication delays.

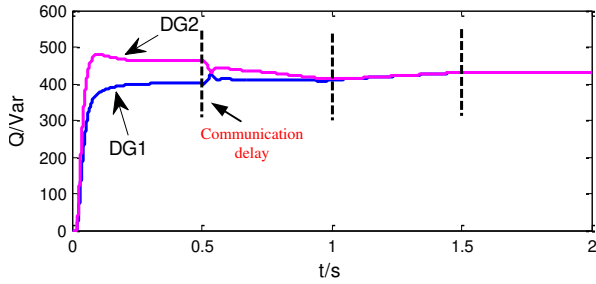

Fig. 10 Output reactive powers of the two inverters when 0.02s time delay occurs in synchronization signal of DG1 unit

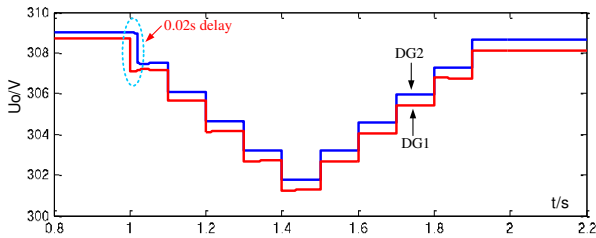

Fig. 11 DG output voltage of the inverters when 0.02s time delay occurs in synchronization signal of DG1 unit

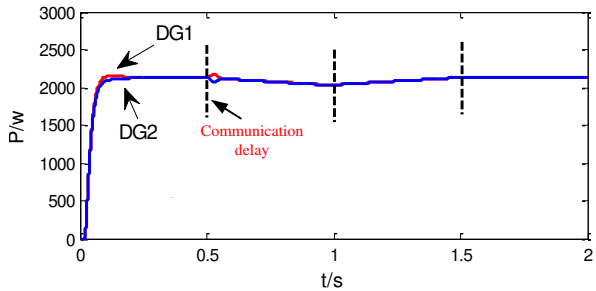

Fig. 12 Output active powers of the two inverters when 0.02s time delay occurs in synchronization signal of DG1 unit

3) Case 3: Effect of load change

In order to test the effect of load change with the proposed method, the active load increases about 1.6kW and the reactive load increases about 0.4kVar at $t=2.5s$, and at $t=4.5s$ the active load decreases about

3.0kW and the reactive load decreases about 0.8kVar. The corresponding simulation results are shown in Fig.13 and 14. As can be seen, a large reactive power sharing deviation appears at $t=2.5s$ and $t=4.5s$. However, the deviation becomes almost zero after a while. Fig.15 illustrates the corresponding output voltage waveforms. It can be found that there exists a obvious output voltage decrease and output voltage increase process during each reactive power sharing error reduction process.

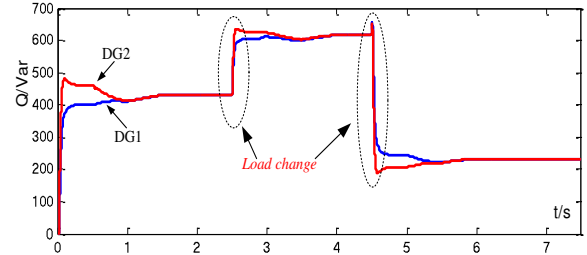

Fig. 13 Reactive power sharing performance of the improved droop control (with load varying)

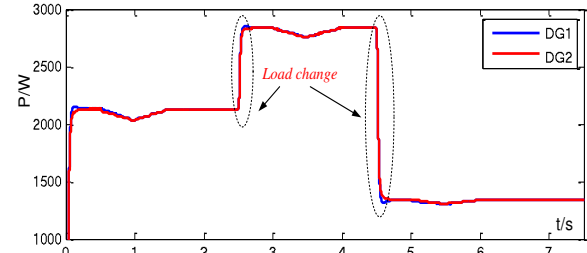

Fig. 14 Active power sharing performance of the improved droop control (with load changing)

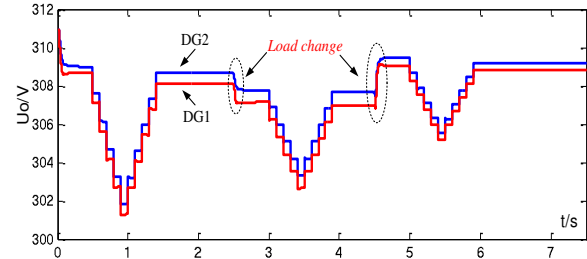

Fig. 15 DG output voltage of the improved droop control (with load changing)

B. Experimental Results

A microgrid prototype is built in lab as shown in Fig.16. The microgrid consists of two micro-sources based on the single-phase inverter. The parameters for output filter are the same as those in simulation. The load consists of a resistor of 16Ω and an inductor of 3mH. The sample frequency is 12.8 kHz. A permissible minimum time interval between two

consecutive synchronization events is 0.5s. The permissible minimum output voltage does not less than the rated voltage by 90%.



Fig.16 Prototype of parallel inverters system setup

Fig. 17 and Fig.18 shows the measured waveforms with the conventional and improved droop control methods, respectively. The waveforms from top to down are circular current ($i_{0H}=i_{01}-i_{02}$), the output current of inverter 1 (i_{01}), the output current (i_{02}) of inverter 2 and PCC voltage (U_L), respectively. As can be seen from Fig. 17, there is a quite large phase difference between two output currents when the conventional droop control is applied. As a result, the circular current is pretty high and the peak value of circular current is up to 1.80 A. The main reason for it is the impedance difference in DG feeders. Compared with the circular current in Fig.17, the circular current in Fig.18 is very small, which indicates that the improved method is efficient in reducing the circular current mainly caused by the output reactive power difference between the inverters.

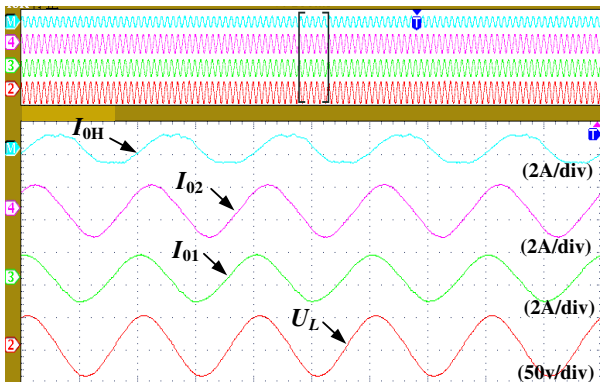

Fig.17 Steady state experimental waveforms with the conventional droop control.

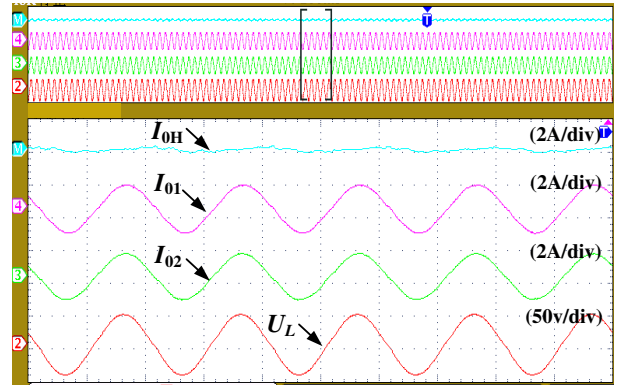

Fig.18 Steady state experimental waveforms with the improved droop control.

Fig.19 shows the steady-state output active and reactive power of each inverter with the conventional and the improved droop control. Fig.19 (a) shows the results with the conventional droop. The steady-state output active powers of the inverters are 31.4 W and 30 W, and the output reactive powers are 21.2 Var and -10.4 Var. When using conventional P - f droop control, no active power divergence appear since frequency is a global variable, i.e. same frequency can be measured along the microgrid; however, voltage may drop along the microgrid power lines, which produces the well know reactive power divergence. Fig. 19(b) shows the results with the improved droop. As can be seen, the output active powers of the inverters are 30.6 W and 31.1 W, and the reactive powers are 3.9 Var and 4.4 Var. These results indicates that the proposed improved droop control has no effect on the active power sharing performance, but makes reactive power be shared precisely .

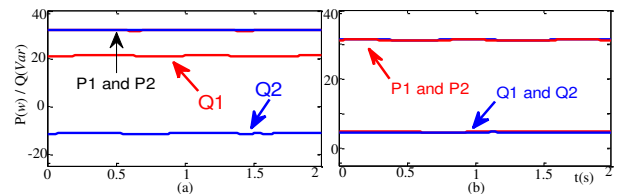

Fig. 19 Steady-state active power and reactive power a) with the conventional droop; b) with the improved droop control.

To verify the effectiveness of the sharing error reduction operation and voltage recovery operation of the proposed method, the experiments with only one operation being continuously used are performed. As can be seen from Fig.20, the circular current converges to a small value gradually when only the reactive power sharing error reduction operation is performed. In the meanwhile, a continuous decrease in

PCC voltage could be found. Fig.21 shows the results when only the voltage recovery operation is performed. It can be seen that the PCC voltage increases linearly during this time, and the circulating current is always small and be almost kept constant. Fig.22 shows the results when the two operations are combined. i.e. the proposed method is applied. The circulating current is controlled to be small value, and the quality of the PCC voltage is guaranteed successfully.

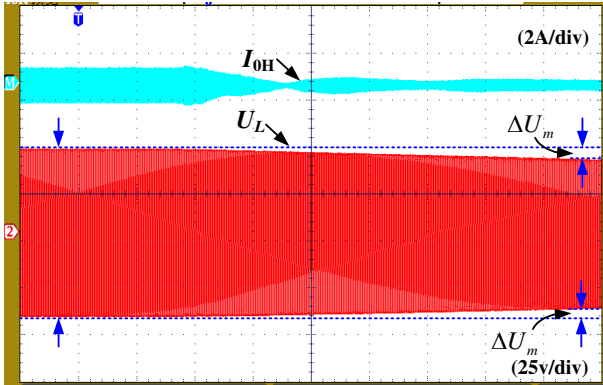

Fig. 20 Circulating current and PCC voltage waveforms of DGs with only sharing error reduction operation performed.

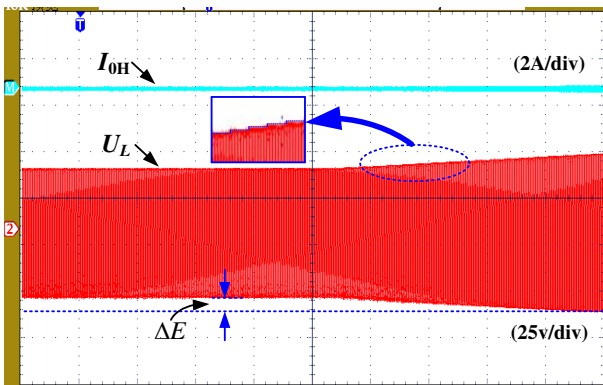

Fig. 21 Circulating current and PCC voltage waveforms of DGs with only voltage recovery operation performed.

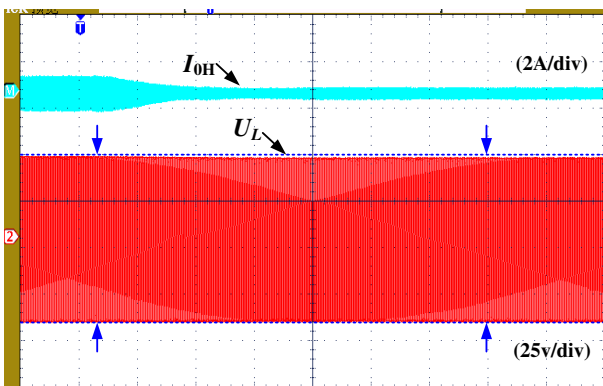

Fig.22 Circulating current and PCC voltage waveforms of DGs with the improved droop.

To test the sensitivity of the proposed method to

synchronization signal, a 0.2 s delay is intentionally added to the synchronization signal received by DG1 unit every time. The associated experimental results are shown in Fig. 23. Compared to the normal case, there is no obvious difference between the two cases, and the reactive power sharing error can still reduce to a small value. Therefore, the proposed method is robust to the communication delay because all the necessary operations only need to be completed in an interval, not a critical point.

Fig.24 shows the experimental results when the synchronization signal of DG1 unit fails, which is equivalent to the time delay is infinity. It is obvious that, before $t=t_1$, the circulating current is kept to be a small value because the improved droop control is in effect. After $t=t_1$, the sharing error reduction operation and voltage recovery operation are disabled due to the lost of the synchronization signal of DG1 unit. As a result, the peak value of the circulating current increases to about 2.8A from a small value. In conclusion, the results in Fig.23 and Fig.24 indicate that the proposed method only needs a low-bandwidth requirement, and it is robust to a small time delay of communication. However, once communication fails completely, the reactive power sharing accuracy performance may be worse.

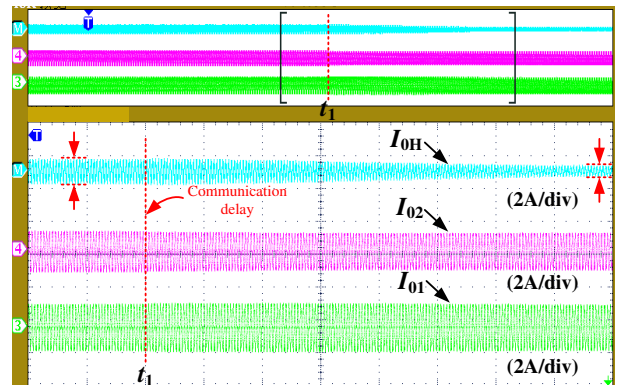

Fig.23 Output current and circulating current waveforms when 0.2 s time delay occurs in synchronization signal of DG1 unit.

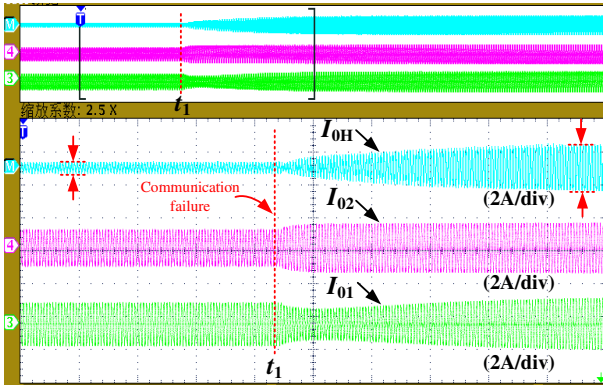

Fig.24 Output current and circulating current waveforms when the synchronization signal is lost in DG1 unit.

V CONCLUSIONS

In this paper, a new reactive power control for improving the reactive sharing was proposed for power electronics interfaced DG units in AC micro-grids. The proposed control strategy is realized through the following two operations: sharing error reduction operation and voltage recovery operation. The first operation changes the voltage bias of the conventional droop characteristic curve periodically, which is activated by the low-bandwidth synchronization signals. The second operation is performed to restore the output voltage to its rated value. The improved power sharing can be achieved with very simple communications among DG units. Furthermore, the plug-and-play feature of each DG unit will not be affected. Both simulation and experimental results are provided to verify the effectiveness of the proposed control strategy.

REFERENCES

- [1] W. Deng, W. Pei, and Z. Qi, "Impact and improvement of distributed generation on voltage quality in micro-grid," in Third International Conference on Electric Utility Deregulation and Restructuring and Power Technologies, Apr. 2008, pp. 1737–1741.
- [2] Lasseter R H. Microgrids [C]//Power Engineering Society Winter Meeting, 2002. IEEE. IEEE, 2002, 1: 305-308.
- [3] Lopes J A P, Moreira C L, Madureira A G Defining control strategies for microgrids islanded operation [J]. Power Systems, IEEE Transactions on, 2006, 21(2): 916-924.
- [4] Y. W. Li, D. M. Vilathgamuwa, and P. C. Loh, "Design, analysis, and real-time testing of a controller for multibus microgrid system," IEEE Trans. Power Electron., vol. 19, no. 5, pp. 1195–1204, Sep. 2004.
- [5] Y. A.-R. I.Mohamed and E. F. El-Saadany, "Adaptive decentralized droop controller to preserve power sharing stability of paralleled inverters indistributed generation microgrids," IEEE Trans. Power Electron., vol. 23,no. 6, pp. 2806–2816, Nov. 2008.
- [6] Guerrero, Josep M., et al. "Control strategy for flexible microgrid based on parallel line-interactive UPS systems." *Industrial Electronics, IEEE Transactions on* 56.3 (2009): 726-736.
- [7] Guerrero, Josep M., et al. "Hierarchical control of droop-controlled AC and DC microgrids—a general approach toward standardization." *Industrial Electronics, IEEE Transactions on* 58.1 (2011): 158-172.
- [8] Chandorkar M C, Divan D M, Adapa R. Control of parallel connected inverters in standalone ac supply systems [J]. Industry Applications, IEEE Transactions on, 1993, 29(1): 136-143.
- [9] Guerrero J M, Matas J, de Vicuña L G, et al. Wireless-control strategy for parallel operation of distributed-generation inverters [J]. Industrial Electronics, IEEE Transactions on, 2006, 53(5): 1461-1470.
- [10] De Brabandere K, Bolsens B, Van den Keybus J, et al. A voltage and frequency droop control method for parallel inverters [J]. Power Electronics, IEEE Transactions on, 2007, 22(4): 1107-1115.
- [11] Guerrero J M, GarcíadeVicuna L, Matas J, et al. Output impedance design of parallel-connected UPS inverters with wireless load-sharing control [J]. Industrial Electronics, IEEE Transactions on, 2005, 52(4): 1126-1135.
- [12] Li Y W, Kao C N. An accurate power control strategy for power-electronics-interfaced distributed generation units operating in a low-voltage multibus microgrid [J]. Power Electronics, IEEE Transactions on, 2009, 24(12): 2977-2988.
- [13] Guerrero J M, Matas J, de Vicuña L G, et al. Decentralized control for parallel operation of distributed generation inverters using resistive output impedance[J]. Industrial Electronics, IEEE Transactions on, 2007, 54(2): 994-1004.
- [14] Guerrero J M, de Vicuña L G, Matas J, et al. A wireless controller to enhance dynamic performance of parallel inverters in distributed generation systems[J]. Power Electronics, IEEE Transactions on, 2004, 19(5): 1205-1213.
- [15] Tuladhar A, Jin H, Unger T, et al. Control of parallel inverters in distributed AC power systems with consideration of line impedance effect [J]. IEEE Trans. Industry Electronics, 2000, 36(1): 131-138.
- [16] He J, Li Y W. An enhanced microgrid load demand sharing strategy [J]. Power Electronics, IEEE Transactions on, 2012, 27(9): 3984-3995.
- [17] Sao C K, Lehn P W. Autonomous load sharing of voltage source converters[J]. Power Delivery, IEEE Transactions on, 2005, 20(2): 1009-1016.
- [18] Moawwad A, Khadkikar V, Kirtley J L. A New P-Q-V Droop Control Method for an Interline Photovoltaic (I-PV) Power

- System[J]. IEEE transactions on power delivery, 2013, 28(2): 658-668.
- [19] Coelho E A A, Cortizo P C, Garcia P F D. Small-signal stability for parallel-connected inverters in stand-alone AC supply systems. IEEE Transactions on Industry Applications, 2002, 38(2): 533-542.
- [20] Pogaku N, Prodanovic M, Green T C. Modeling, Analysis and Testing of Autonomous Operation of an Inverter-Based Microgrid. IEEE Transactions on Power Electronics, 2007, 22(2): 613-625.
- [21] Mahmood, H.; Michaelson, D.; Jiang, J., "Accurate Reactive Power Sharing in an Islanded Microgrid using Adaptive Virtual Impedances," *Power Electronics, IEEE Transactions on*, vol.PP, no.99, pp.1,1.
- [22] Qing-Chang Zhong, "Robust Droop Controller for Accurate Proportional Load Sharing Among Inverters Operated in Parallel," *Industrial Electronics, IEEE Transactions on*, vol.60, no.4, pp.1281,1290, April 2013.
- [23] C. N. Rowe, T. J. Summers, R. E. Betz, D. J. Cornforth, and T. G. Moore, "Arctan power-frequency droop for improved microgrid stability," *IEEE Trans. Power Electron.*, vol. 28, no. 8, pp. 3747-3759, Aug. 2013.
- [24] A. Luna, F. Blaabjerg, and P. Rodríguez, "Control of power converters in AC microgrids," *IEEE Trans. Power Electron.*, vol. 27, no. 11, pp. 4734-4749, Nov. 2012.