

June 1984

An Improved Procedure for Laboratory Rearing of the Corn Earworm, *Heliothis Zea* (Lepidoptera: Noctuidae)

G. P. Waldbauer
University of Illinois

R. W. Cohen
University of Illinois

S. Friedman
University of Illinois

Follow this and additional works at: <https://scholar.valpo.edu/tgle>



Part of the [Entomology Commons](#)

Recommended Citation

Waldbauer, G. P.; Cohen, R. W.; and Friedman, S. 1984. "An Improved Procedure for Laboratory Rearing of the Corn Earworm, *Heliothis Zea* (Lepidoptera: Noctuidae)," *The Great Lakes Entomologist*, vol 17 (2)
Available at: <https://scholar.valpo.edu/tgle/vol17/iss2/10>

This Peer-Review Article is brought to you for free and open access by the Department of Biology at ValpoScholar. It has been accepted for inclusion in *The Great Lakes Entomologist* by an authorized administrator of ValpoScholar. For more information, please contact a ValpoScholar staff member at scholar@valpo.edu.

AN IMPROVED PROCEDURE FOR LABORATORY REARING OF THE CORN EARWORM, *HELIOTHIS ZEA* (LEPIDOPTERA: NOCTUIDAE)

G. P. Waldbauer, R. W. Cohen and S. Friedman¹

ABSTRACT

An improved method for the laboratory rearing of the corn earworm, *Heliothis zea*, is described. The rearing medium is a modification of the commonly used wheat germ diet. An oviposition chamber, a feeder for adults, and a simple and inexpensive controlled humidity chamber are described.

The corn earworm, *Heliothis zea* (Boddie), is often used as a laboratory animal and is one of the most important insect pests in North America. The rearing procedure outlined below is based in part on the techniques of Berger (1963), Ignoffo (1965), and Young et al. (1976). The artificial diet used here is a lineal descendant of the wheat germ medium first developed by Adkisson et al. (1960) for rearing the pink bollworm, *Pectinophora gossypiella* (Saunders). This medium was subsequently modified for use with *Heliothis zea* by Vanderzant et al. (1962), Berger (1963), and Ignoffo (1966). We have made a few additional modifications, largely following Kogan and Parra's (1981) soybean looper diet. Up to now we have reared 34 successive generations of *H. zea* using this procedure.

PHYSICAL CONDITIONS DURING REARING

The larvae are held in an environment chamber at 25°C and a 16:8 light:dark photoperiod to prevent the induction of diapause. There is no need to control humidity externally because the larvae, confined in closed cups on a moist diet, are already in a sufficiently humid microenvironment.

Eggs, pupae, and adults are held in controlled humidity chambers (Fig. 1) in a rearing room at 25°C and a 16:8 light:dark photoperiod. The relative humidity (r.h.) in the chamber is kept at about 70%. Maintenance of a high r.h. is important because the insects otherwise desiccate and die prematurely. Adults in dry conditions, for example, often die without laying eggs. This problem is especially acute in northern climates where the r.h. may be as low as 10–20% in heated buildings in the winter.

The humidity chamber (Fig. 1) is 1.35 m tall by 1.47 m long by 0.54 m wide. It consists of a welded 3 cm angle-iron frame covered top and sides with transparent sheet plastic held on with masking tape. The underside of the chamber fits flush against the floor. The entire expanse of the front opens through two hinged doors. Three shelves of expanded metal, held by adjustable shelf brackets, permit the passage of air. Moisture is provided by a 38 by 49-cm plastic pan of deionized water in the bottom of the chamber with a small blower directed at its surface. The blower is clamped to one of two 1.3-cm diameter steel rods that extend from top to bottom in the middle of the chamber. The percent r.h. is controlled by covering or uncovering two rows of 18 1.5-cm wide circular holes on each end of the plastic top. These holes are easily made with a heated cork borer.

During the scotophase an "artificial moon" must be provided because the moths will neither mate nor lay eggs in complete darkness. The "moon" is a 15 W light bulb in a

¹Department of Entomology, University of Illinois, Urbana, IL 61801.

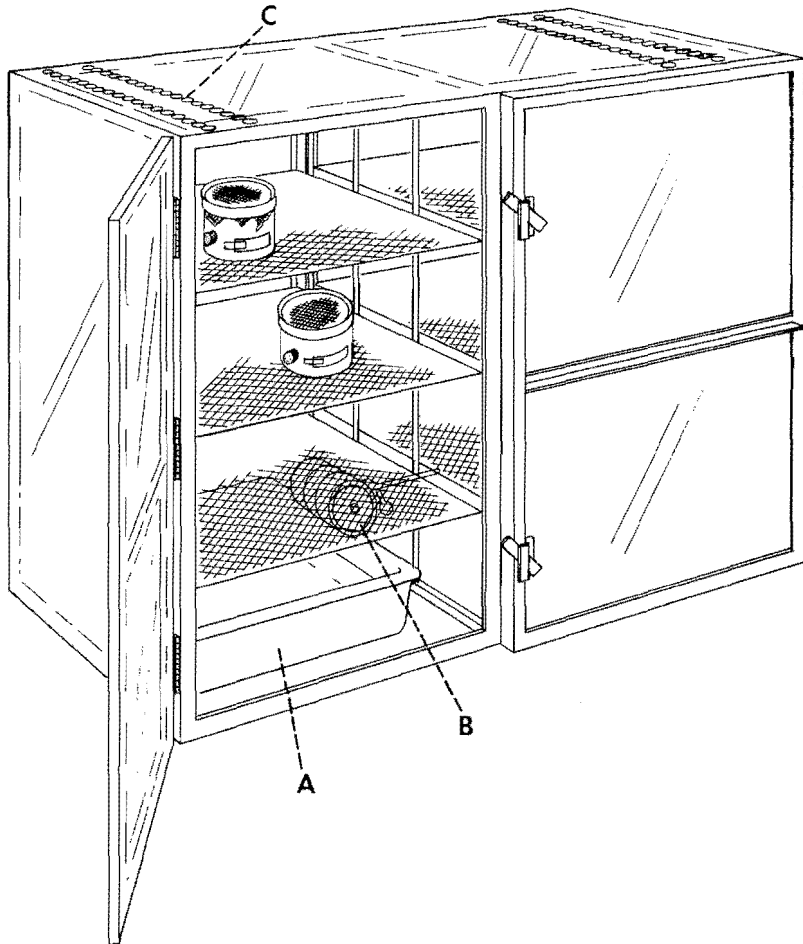

Fig. 1. Frontal view of the controlled humidity chamber with one door open. Note the pen of water (A), the blower (B), and the holes that can be covered and uncovered to control relative humidity (C).

gooseneck lamp placed about 2.5 m from the humidity control chamber. The hemispherical metal shade of the lamp is placed with its open side almost flush against the wall, so that only a small amount of light escapes.

THE EGGS

The oviposition chamber (Fig. 2) is made from a cylindrical, one-gallon, cardboard ice cream container (Standard Packaging Corp., Union, NJ) with the insert pushed out of the rim of the lid. The rim is then used to hold a cheesecloth cover in place on the container.

About 80% or more of the eggs are laid on the cheesecloth that covers the top of the oviposition chamber. The cheesecloth, with the adhering eggs, is removed daily and replaced with a fresh cloth. The cloth is easily changed, without moths escaping, by removing the rim from the chamber, placing a fresh cloth over the old one, and then gently pulling the old cloth out from beneath. The eggs are surface sterilized by placing the cloth in a 10% formalin (3.7% formaldehyde) solution for 3 min followed by a 6-min rinse in tepid running tap water. (Sterilization with formaldehyde, unlike sterilization with sodium hypochlorite, does not cause the eggs to detach from the cloth.) The cloths are dried on a blotter and then placed individually in 8-oz paper food cups with a transparent plastic lid (Dixie Cup, American Can Co., Easton, PA). During peak egg laying each oviposition chamber produces several thousand eggs per day. Developing eggs turn dark on the second day and hatch on the third day.

THE LARVAE

Larvae are reared on the artificial medium whose ingredients are listed in Table 1. The medium is prepared as follows: The group A ingredients, water and agar, are poured into a large flask and placed in an autoclave where the agar dissolves within 15 min. The flask is then allowed to cool for 10 min. Meanwhile, the wheat germ and about one-half of the water (group B) are placed in a small blender and blended to a fine pabulum. The rest of the group B ingredients are then poured into a large blender. The wheat germ pabulum is rinsed into the large blender with the remaining water, and the mixture is blended. The agar solution is then added and the mixture is again blended slowly until it cools to below 60° C. Finally, the group C ingredients are added, and the diet is blended for 3 or 4 min.

The diet is immediately poured into 1-oz transparent plastic condiment cups (Fill-Rite, Inc., Newark, NJ) using large beakers that have been preheated in a 60° C oven. The cups are approximately half filled. The diet cups may be capped after one-half hour. Six or seven pin holes are made in the center of each opaque plastic cap (Bio-Serv, Inc., Frenchtown, NJ) to allow for air circulation.

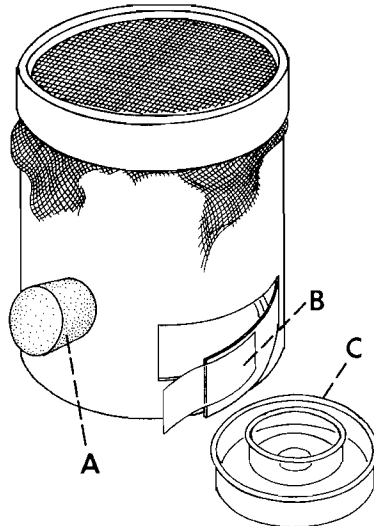

Fig. 2. The oviposition chamber. Note the stoppered hole for the insertion of moths (A), the hatchway for insertion of the feeder (B), and the feeder, shown without cotton wool (C).

Table 1. Ingredients for an amount of *Heliothis zea* rearing medium sufficient to rear about 250 larvae.

Group A:	Agar	75 g
	Water	2200 ml
Group B:	Vitamin-free casein	126 g
	Alfalfa meal	54 g
	Sucrose	96 g
	Wheat germ	108 g
	Wesson's salt mixture	36 g
	Alphacel	18 g
	4M KOH	18 ml
	Water	880 ml
	Wheat germ oil	7 g (ca. 10 ml)
Group C:	Vanderzant modification vitamin mixture (Nutritional Biochemicals)	36 g
	Sorbic acid	6.8 g
	Methyl-p-hydroxybenzoate	6.8 g
	Ascorbic acid	13 g
	Streptomycin	0.5 g
	10% formaldehyde (27.0% formalin)	15 ml

A small camel's hair brush that has been cut down so that it has only six to eight bristles is used gently to place one newly hatched larva in each cup. After capping, the diet cups are placed upside down in wooden racks (inside dimensions: 52.5 by 35.5 by 3.0 cm) with a hardware cloth bottom to allow for air circulation. The racks, designed to hold 96 cups in 12 rows of eight each, are held in an environmental chamber as described above. They are stacked with 2-cm wide sticks between them for spacing. On the third or fourth day the cups are examined and turned over. (Missing or dead larvae are replaced from eight cups per rack that were set up with an extra larva in each.) Keeping the cups upside down for the first few days reduces mortality at the second instar from about 15% to about 5% because fewer of the negatively geotactic, first instar larvae starve as a result of wandering about on the lids of the cups. Six to eight racks of diet cups are set up for each generation.

THE PUPAE

Pupation occurs about 17 days after hatching. Most of the larvae dig down to the bottom of the diet cup and form a pupation chamber that is lined with a sparse but strong mesh of silk. The pupae are dug out 1 or 2 days after about 90% of the larvae have pupated, thus avoiding injury either to teneral pupae or pharate adults. The pupae are surface sterilized by immersing them in 0.2% sodium hypochlorite (one part household bleach in 24 parts of water) for 3 min, then in 10% sodium thiosulfate (20 g:200 ml water) for 3 min, and finally in tepid running tap water for 5 min.

The pupae can be sexed by using the characteristics of the pupal abdomen shown in Fig. 3. The sex ratio of 1155 pupae was essentially 1:1, with 50.8% males and 49.2% females. The pupae, segregated by sex, are placed in groups of 50 each in cubical screen eclosion cages that are 30.5 cm on a side and have a cloth sleeve. If more than 50 pupae are placed in a cage, the newly eclosed adults injure each other and the pharate adults that are about to eclose.

THE ADULTS

The adults eclose about 13 days after pupation and are moved to oviposition chambers at that time. (Survival from the first instar to the adult is generally over 80%.) Adults are

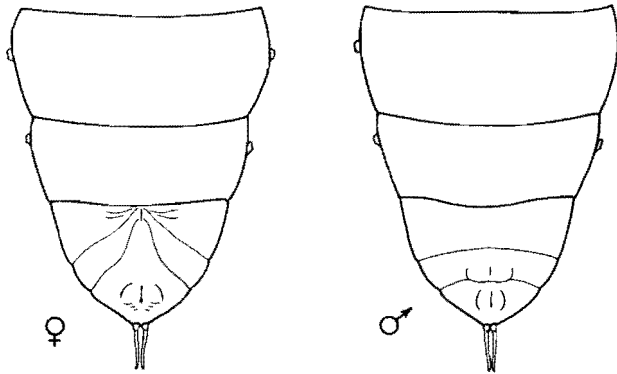

Fig. 3. Ventral views of the ends of the abdomens of male and female pupae of *Heliothis zea*.

moved from the emergence cages to the oviposition chambers by catching them in a condiment cup with a screen bottom; moths that will not fly can be forced into the oviposition chamber by blowing through the screen bottom of the condiment cup. Ten to 12 moths of each sex are placed in each oviposition chamber through a 3.5-cm diameter hole in the side that can be closed with a rubber stopper (Fig. 2). A feeder, composed of a 5-cm petri dish held in the center of a 9-cm petri dish with a bit of Plasticene®, is placed on the floor of the oviposition chamber (Fig. 2). The inner dish holds a wad of cotton soaked with a 10% solution (vol./vol.) of honey in water. The feeder is moved in and out of the chamber through a 3 by 11-cm opening cut near the bottom of the chamber. The cover of the opening can be pulled open or held shut with a length of tape. The feeders must be washed and the honey solution changed daily because the solution begins to ferment on the second day. Fermenting honey solution causes the moths to bloat and die prematurely, greatly decreasing the yield of eggs. The design of the feeder prevents spillage and subsequent fermentation of honey water in the oviposition cage. Six to 10 chambers are set up for each generation. The females begin laying eggs in large numbers 3 or 4 days later.

MINIMIZING INBREEDING

Inbreeding is minimized by promoting heterogeneous mating within the culture and by introducing new insects from the field at the end of each summer. Heterogeneous mating is promoted by identifying the progeny of the adults in each oviposition cage, and by mating females from one group of progeny with males from another. The lineages are followed in succeeding generations, and females are never mated with their first cousins. The culture is outcrossed each summer by mating laboratory-reared females with males reared from larvae collected in the field. Using only males from the wild population prevents accidental introduction of the naturally occurring microsporidian *Nosema heliothidis* Lutz and Splendore into the culture. This microsporidian is transovarially transmitted by females, but is not venereally transmitted by males (J. V. Maddox, pers. comm.).

STARTING AND MAINTAINING A DISEASE-FREE CULTURE

A culture free of infection by *N. heliothidis* can be started by using a variation of the Pasteur technique. Field-collected larvae are reared to the adult stage, and groups of these

adults are then placed in oviposition chambers as described above. After sufficient eggs have been produced, the females are killed and examined for *N. heliothidis* spores. If spores are found in one or more females of a group, the larval progeny of that group are checked for the presence of *N. heliothidis* by examining fecal smears for spores. Spores can be seen under a phase contrast microscope. Infected larvae are discarded.

It is particularly important to take precautions against the introduction of *N. heliothidis* into the culture. It is the pathogen most likely to be encountered when starting a colony from field-collected insects. Furthermore, it causes a chronic disease that may go unnoticed until it eventually causes an unacceptable level of mortality. In the meantime, it slows the developmental rate and may obscure the effects of an experimental variable (J. V. Maddox, pers. comm.).

The culture is maintained essentially disease free by strict adherence to routine sanitary procedures. Spatulas are flamed if they are used to dig in diet cups that contain a larva that may be diseased. Cages and oviposition chambers are autoclaved between generations. Diet cups are used only once, and all discarded cups are sealed in plastic trash bags that line wastebaskets. Perhaps the most important measure is the routine surface sterilization of eggs and pupae described above.

ACKNOWLEDGMENTS

We thank Joseph V. Maddox and May Berenbaum for reading the manuscript and Alice Prickett for the drawings. This material is based upon work supported by the USDA Competitive Research Grants Program, Office of Grants and Program Systems, Science and Education, under Grant No. 83-CRCR-1-1207.

LITERATURE CITED

- Adkisson, P. L., E. S. Vanderzant, D. L. Bull, and W. E. Allison. 1960. A wheat germ medium for rearing the pink bollworm. *J. Econ. Entomol.* 53:759-762.
- Berger, R. S. 1963. Laboratory techniques for rearing *Heliothis* species on artificial medium. USDA Agric. Res. Serv. Ars-33-84, 4 p.
- Ignoffo, C. M. 1965. The nuclear-polyhedrosis virus of *Heliothis zea* (Boddie) and *Heliothis virescens* (Fabricius) II. Biology and propagation of diet-reared *Heliothis*. *J. Invertbr. Pathol.* 7:217-226.
- . 1966. Insect viruses. p. 501-530 in C. N. Smith (ed.). *Insect colonization and mass production*. Academic Press, New York.
- Kogan, M. and J. R. P. Parra. 1981. Techniques and applications of measurements of consumption and utilization of food by phytophagous insects. p. 337-352 in G. Bhaskaran, S. Friedman, and J. G. Rodriguez (eds.). *Current topics in insect endocrinology and nutrition*. Plenum Press, New York.
- Vanderzant, E. S., C. D. Richardson, and S. W. Fort, Jr. 1962. Rearing of the bollworm on artificial diet. *J. Econ. Entomol.* 55:140.
- Young, J. R., J. J. Hamm, R. L. Jones, W. D. Perkins, and R. L. Burton. 1976. Development and maintenance of an improved laboratory colony of corn earworms. USDA Agric. Res. Serv. S-110, 4 p.