

NASA
TP
1903
c. 1

NASA Technical Paper 1903

An Improved Transverse Shear Deformation Theory for Laminated Anisotropic Plates

M. V. V. Murthy

NOVEMBER 1981

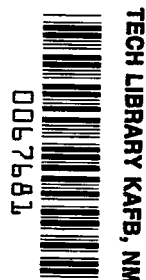

LOAN COPY: RETURN TO
AFWL TECHNICAL LIBRARY
KIRTLAND AFB, N.M.

NASA



NASA Technical Paper 1903

An Improved Transverse Shear Deformation Theory for Laminated Anisotropic Plates

M. V. V. Murthy
*Langley Research Center
Hampton, Virginia*



National Aeronautics
and Space Administration

**Scientific and Technical
Information Branch**

1981

SUMMARY

An improved transverse shear deformation theory for laminated anisotropic plates under bending is presented. The theory eliminates the need for an arbitrarily chosen shear correction factor. For a general laminate with coupled bending and stretching, the constitutive equations connecting stress resultants with average displacements and rotations are derived. Simplified forms of these relations are also obtained for the special case of a symmetric laminate with uncoupled bending. The governing equation for this special case is obtained as a sixth-order equation for the normal displacement requiring prescription of the three physically natural boundary conditions along each edge. For the limiting case of isotropy, the present theory reduces to an improved version of Mindlin's theory.

Numerical results are obtained from the present theory for an example of a laminated plate under cylindrical bending. Comparison with results from exact three-dimensional analysis shows that the present theory is more accurate than other theories of equivalent order.

INTRODUCTION

Classical bending theory produces errors when the ratio of the elastic modulus to shear modulus becomes large. Advanced composites like graphite-epoxy and boron-epoxy have ratios of about 25 and 45, respectively, in contrast to 2.6 which is typical of isotropic materials. These high ratios render classical plate theory inaccurate for analysis of composite plates. Structures from advanced composites are constructed in layered form with each layer being orthotropic. Consequently, for analysis of composite plates, a satisfactory transverse shear deformation theory for laminated anisotropic plates is needed.

Current shear deformation theories for laminated anisotropic plates have one drawback or another. The more rigorous theories (refs. 1 and 2) are cumbersome because of their high order and inconvenient boundary conditions. Most of the simpler, sixth-order theories (refs. 3 to 5) require an arbitrary correction to the transverse shear stiffness matrix. Cohen's sixth-order theory (ref. 6) does not require a correction factor but, like all other sixth-order theories (refs. 3 to 5), his theory is no better than classical plate theory in predicting stresses.

Herein, a sixth-order bending theory for laminated anisotropic plates is developed that requires just the three natural boundary conditions in uncoupled bending problems. These three conditions are the normal moment, the twisting moment, and the transverse shear force. Alternatively, any one of these conditions could be replaced by prescription of the corresponding displacement degree of freedom, such as rotation or normal displacement. The theory does

not require an arbitrary shear correction factor. Unlike other theories of equivalent order (refs. 3 to 6), the present theory gives an accurate prediction of stresses.

The present theory uses a displacement approach like that in Mindlin's theory (ref. 7) and its straightforward extensions to laminated anisotropic plates (refs. 3 to 5). However, in contrast to earlier theories, a special displacement field is used. The displacement field is chosen so that the transverse shear stress vanishes on the plate surfaces. This important modification eliminates the need for using an arbitrary shear correction factor, characteristic of other theories (refs. 3 to 5).

The theory is first developed for a general unsymmetric laminate. Simplified relations are then derived for a symmetric laminate in which bending and stretching are uncoupled. The results are further specialized for a symmetric cross-ply laminate, which is a case of classical orthotropy. For the limiting case of isotropy, the present theory reduces to an improved version of Mindlin's theory (ref. 7).

Cylindrical bending of a three-layered laminate is considered, as a numerical example, to compare results from the present theory with those from the exact solution and other theories.

SYMBOLS

A_{ij}	"differential" bending and twisting rigidities for laminated anisotropic plate ($i, j = 1, 2, 3$)
C_{ij}	elements of stiffness matrix for individual lamina connecting stresses and strains ($i = 1, 2, 3, \dots, 6$)
\bar{C}_{ij}	elements of reduced stiffness matrix for individual lamina defining constitutive relations of plane stress type ($i = 1, 2, 3$)
$\bar{C}_{ij}^{(n)}$	$= \int_{-h/2}^{h/2} \bar{C}_{ij} z^n dz$
D	bending rigidity of isotropic plate, $\frac{Eh^3}{12(1 - \nu^2)}$
D_{ij}	bending and twisting rigidities for laminated anisotropic plate ($i, j = 1, 2, 3$)
E	Young's modulus of isotropic plate
E_ℓ, E_t	elastic moduli of individual lamina in longitudinal and transverse directions, respectively
G	shear modulus of isotropic plate

- G_{lt}, G_{tt} shear moduli of individual lamina
- h laminate thickness
- k shear correction factor in Whitney and Pagano's theory
- K_1, K_2 transverse shear stiffness coefficients for laminated anisotropic plate
- M_x, M_y, M_{xy} bending and twisting moments per unit length of laminate element
- $$M = \begin{Bmatrix} M_x \\ M_y \\ M_{xy} \end{Bmatrix}$$
- N_x, N_y, N_{xy} membrane forces per unit length of laminate element
- $$N = \begin{Bmatrix} N_x \\ N_y \\ N_{xy} \end{Bmatrix}$$
- Q_x, Q_y transverse shear forces per unit length of laminate element
- $$Q = \begin{Bmatrix} Q_x \\ Q_y \end{Bmatrix}$$
- q distributed normal load per unit area of laminate surface, positive in direction of increasing z
- s span length in numerical example
- u, v, w displacements in x -, y -, and z -directions, respectively
- U, V, W average values of displacement components over thickness
- x, y, z Cartesian coordinates with z -axis oriented in thicknesswise direction and measured from middle plane of laminate (fig. 1)
- β_x, β_y average values of rotations of line normal to middle surface over thickness
- $\Delta_1, \Delta_2, \dots, \Delta_{11}$ linear differential operators
- $$\left. \begin{matrix} \epsilon_x, \epsilon_y, \epsilon_z \\ \gamma_{xy}, \gamma_{yz}, \gamma_{xz} \end{matrix} \right\} \text{ strain components in Cartesian coordinates}$$

- λ angle of fiber orientation
- ν Poisson's ratio of isotropic plate
- ν_{lt}, ν_{tt} Poisson's ratios of individual lamina
- $\left. \begin{array}{l} \sigma_x, \sigma_y, \sigma_z \\ \tau_{xy}, \tau_{yz}, \tau_{xz} \end{array} \right\}$ stress components in Cartesian coordinates
- χ transverse shear function in Reissner's theory for isotropic plates under bending

Subscripts:

- l, t longitudinal and transverse directions of unidirectional lamina, respectively
- max maximum value
- S, B stretching and bending components, respectively
- SS, BB applied to matrices, refer to stretching and bending parts, respectively
- SB, BS applied to matrices, refer to stretching-bending coupling

Superscript:

- T transpose of matrix

Matrix notation:

- [] matrix
- { } column matrix
- [] row matrix
- [O] null matrix

DEVELOPMENT OF THE THEORY

The present theory is developed by using a displacement approach. The inplane displacements u and v are approximated by cubic polynomials in z . The out-of-plane displacement w is assumed to be constant with respect to z . By requiring that shear stresses vanish on the surface, coefficients of

the polynomials are related. By using these relations, the displacement field is completely defined in terms of z , "average" displacements U , V , and W , and "average" rotations of a line normal to the middle surface β_x and β_y .

Then the stress distribution through the thickness is determined from the constitutive relations of individual layers. Next the laminate constitutive equations, which relate the forces and moments to displacements U , V , and W and rotations β_x and β_y , are obtained from stresses by integration through the thickness.

Finally, for the case of a symmetric laminate, the moments and transverse shear forces from the plate constitutive equations are substituted into the three plate equilibrium equations. By eliminating all quantities except W , a single governing equation in terms of W is obtained.

Unsymmetric Laminate

The general case of an unsymmetric laminate with stretching-bending coupling is considered first. The constitutive relations for any individual lamina are

$$\begin{Bmatrix} \sigma_x \\ \sigma_y \\ \tau_{xy} \\ \sigma_z \end{Bmatrix} = \begin{bmatrix} C_{11} & C_{12} & C_{13} & C_{14} \\ C_{12} & C_{22} & C_{23} & C_{24} \\ C_{13} & C_{23} & C_{33} & C_{34} \\ C_{14} & C_{24} & C_{34} & C_{44} \end{bmatrix} \begin{Bmatrix} \epsilon_x \\ \epsilon_y \\ \gamma_{xy} \\ \epsilon_z \end{Bmatrix} \quad (1)$$

$$\begin{Bmatrix} \tau_{xz} \\ \tau_{yz} \end{Bmatrix} = \begin{bmatrix} C_{55} & C_{56} \\ C_{56} & C_{66} \end{bmatrix} \begin{Bmatrix} \gamma_{xz} \\ \gamma_{yz} \end{Bmatrix} \quad (2)$$

where the coordinate system is shown in figure 1. The σ_z is assumed to be small in comparison with other normal stresses and is neglected. Whitney and Pagano (ref. 4) have shown that, with this assumption, equation (1) reduces to the following contracted form:

$$\begin{Bmatrix} \sigma_x \\ \sigma_y \\ \tau_{xy} \end{Bmatrix} = \begin{bmatrix} \bar{C}_{11} & \bar{C}_{12} & \bar{C}_{13} \\ \bar{C}_{12} & \bar{C}_{22} & \bar{C}_{23} \\ \bar{C}_{13} & \bar{C}_{23} & \bar{C}_{33} \end{bmatrix} \begin{Bmatrix} \epsilon_x \\ \epsilon_y \\ \gamma_{xy} \end{Bmatrix} \quad (3)$$

where

$$\bar{c}_{ij} = c_{ij} - \frac{c_{i4}c_{j4}}{c_{44}} \quad (4)$$

The strains in equation (3) are determined from an assumed distribution of displacements through the thickness. The displacements are approximated as

$$u = u_0(x,y) + zu_1(x,y) + z^2u_2(x,y) + z^3u_3(x,y) \quad (5)$$

$$v = v_0(x,y) + zv_1(x,y) + z^2v_2(x,y) + z^3v_3(x,y) \quad (6)$$

$$w = W(x,y) \quad (7)$$

The polynomial representation of u and v as shown in equations (5) and (6) is an important departure from Mindlin's theory (ref. 7) and its extensions to laminated plates (refs. 3 to 5), which assume u and v as linear functions of z . The assumption of a higher order polynomial in z for u and v in plate bending theories is not new. Lo and others (ref. 2) have previously used a cubic polynomial for u and v as in equations (5) and (6). However, in contrast to their theory, u_i, v_i ($i = 0, 1, 2, 3$) in equations (5) and (6) are not independent. Instead, they are chosen so that the condition $\tau_{xz} = \tau_{yz} = 0$ at $z = \pm h/2$ is satisfied. When these four conditions are satisfied, the final number of independent unknowns is five. Thus, the order of the theory is the same as that of earlier low-order theories (refs. 3 to 5). In addition, the physical conditions $\tau_{xz} = \tau_{yz} = 0$ at $z = \pm h/2$ are also satisfied. It was not possible to satisfy these conditions in the earlier theories (refs. 3 to 5).

Because the shear stresses τ_{xz} and τ_{yz} are zero on the two laminate surfaces, equation (2) indicates that the shear strains also must vanish. Consequently, the shear strains determined from equations (5) to (7) must equal zero as

$$\gamma_{zx} = \frac{\partial u}{\partial z} + \frac{\partial w}{\partial x} = u_1 \pm u_2 h + \frac{3}{4} u_3 h^2 + \frac{\partial W}{\partial x} = 0 \quad (8)$$

$$\gamma_{yz} = \frac{\partial v}{\partial z} + \frac{\partial w}{\partial y} = v_1 \pm v_2 h + \frac{3}{4} v_3 h^2 + \frac{\partial W}{\partial y} = 0 \quad (9)$$

Equations (8) and (9) lead to

$$u_2 = v_2 = 0 \quad (10)$$

Equations (8) to (10) indicate that there are in all only five independent unknowns u_0 , u_1 , v_0 , v_1 , and W ; however, the first four lack direct physical interpretation and are inconvenient from the point of view of prescribing boundary conditions. Therefore u_0 , u_1 , v_0 , and v_1 are replaced by four other quantities with physical meaning; namely, "average" inplane displacements U and V and "average" rotations of a line normal to the middle surface, which are defined as

$$\begin{Bmatrix} U \\ V \end{Bmatrix} = \frac{1}{h} \int_{-h/2}^{h/2} \begin{Bmatrix} u \\ v \end{Bmatrix} dz \quad (11)$$

$$\begin{Bmatrix} \beta_x \\ \beta_y \end{Bmatrix} = \frac{12}{h^3} \int_{-h/2}^{h/2} \begin{Bmatrix} u \\ v \end{Bmatrix} z dz \quad (12)$$

"Averaging" here means averaging through the thickness. Equations (11) and (12) are obtained from a least square approximation. Details of derivation of equations (11) and (12) are given in appendix A.

By using equation (10), definitions (11) and (12) yield

$$U = u_0 \quad (13)$$

$$V = v_0 \quad (14)$$

$$\beta_x = u_1 + \frac{3h^2}{20} u_3 \quad (15)$$

$$\beta_y = v_1 + \frac{3h^2}{20} v_3 \quad (16)$$

Solving equations (8), (9), (15), and (16) leads to

$$u_1 = \frac{5}{4} \beta_x + \frac{1}{4} \frac{\partial W}{\partial x} \quad (17)$$

$$u_3 = -\frac{5}{3h^2} \left(\beta_x + \frac{\partial W}{\partial x} \right) \quad (18)$$

$$v_1 = \frac{5}{4} \beta_y + \frac{1}{4} \frac{\partial W}{\partial y} \quad (19)$$

$$v_3 = -\frac{5}{3h^2} \left(\beta_y + \frac{\partial W}{\partial y} \right) \quad (20)$$

From equations (3), (5), (6), and (10), the strain-displacement relations, and the definitions of force and moment stress resultants, there follows

$$\mathbf{N} = \begin{bmatrix} N_x & N_y & N_{xy} \end{bmatrix}^T = \begin{matrix} \mathbf{I} & \phi \\ (3 \times 9) & (9 \times 1) \end{matrix} \quad (21)$$

$$\mathbf{M} = \begin{bmatrix} M_x & M_y & M_{xy} \end{bmatrix}^T = \begin{matrix} \mathbf{J} & \phi \\ (3 \times 9) & (9 \times 1) \end{matrix} \quad (22)$$

where

$$\mathbf{I} = \begin{bmatrix} \mathbf{L}_{SS} & \mathbf{L}_{SB} \\ (3 \times 3) & (3 \times 6) \end{bmatrix} \quad (23)$$

$$\mathbf{J} = \begin{bmatrix} \mathbf{L}_{BS} & \mathbf{L}_{BB} \\ (3 \times 3) & (3 \times 6) \end{bmatrix} \quad (24)$$

$$\mathbf{L}_{SS} = \mathbf{L}_0 \quad (25)$$

$$L_{SB} = \begin{bmatrix} L_1 & & \\ & \vdots & \\ & & L_3 \end{bmatrix} \quad (26)$$

(3x3) (3x3)

$$L_{BS} = L_1 \quad (27)$$

$$L_{BB} = \begin{bmatrix} L_2 & & \\ & \vdots & \\ & & L_4 \end{bmatrix} \quad (28)$$

(3x3) (3x3)

$$L_n = \begin{bmatrix} \bar{C}_{11}^{(n)} & \bar{C}_{12}^{(n)} & \bar{C}_{13}^{(n)} \\ \bar{C}_{12}^{(n)} & \bar{C}_{22}^{(n)} & \bar{C}_{23}^{(n)} \\ \bar{C}_{13}^{(n)} & \bar{C}_{23}^{(n)} & \bar{C}_{33}^{(n)} \end{bmatrix} \quad (29a)$$

(3x3)

$$\bar{C}_{ij}^{(n)} = \int_{-h/2}^{h/2} \bar{C}_{ij} z^n dz \quad \text{for } n = 0, 1, 3 \quad (29b)$$

$$\phi = \begin{Bmatrix} \phi_S \\ \phi_B \end{Bmatrix} \quad (30)$$

$$\phi_S = \langle \phi_0 \rangle \quad (31)$$

$$\phi_B = \begin{Bmatrix} \phi_1 \\ \phi_3 \end{Bmatrix} \quad (32)$$

$$\phi_n = \begin{Bmatrix} \partial u_n / \partial x \\ \partial v_n / \partial y \\ \partial u_n / \partial y + \partial v_n / \partial x \end{Bmatrix} \quad (33)$$

The matrix constitutive equations (21) and (22) are arranged so that matrices corresponding to stretching, bending, and stretching-bending coupling appear separately in the total matrix. These matrices are denoted by the subscripts SS, BB, and SB or BS, respectively. Also, elements of the column matrix ϕ are arranged so that the variables signifying stretching and bending are grouped separately. These groups are denoted by the subscripts S and B, respectively. Although the present formulation is for a general laminate with coupled stretching and bending, the arrangement of matrices allows easy extraction of matrices for symmetric laminate relations. The symmetric laminate case is discussed in a subsequent section.

By combining equations (13), (14), (17), (18), (19), and (20), the column matrix ϕ is expressed as a function of the derivatives of U, V, W, β_x , and β_y as

$$\begin{matrix} \phi & = & H & \phi \\ (9 \times 1) & & (9 \times 11) & (11 \times 1) \end{matrix} \quad (34)$$

where

$$\phi = \begin{Bmatrix} \phi_S \\ \phi_B \end{Bmatrix} \quad (35)$$

$$\phi_S^T = \left[\frac{\partial U}{\partial x} \quad \frac{\partial U}{\partial y} \quad \frac{\partial V}{\partial x} \quad \frac{\partial V}{\partial y} \right] \quad (36)$$

$$\phi_B^T = \left[\frac{\partial \beta_x}{\partial x} \quad \frac{\partial \beta_y}{\partial y} \quad \frac{\partial \beta_x}{\partial y} \quad \frac{\partial \beta_y}{\partial x} \quad \frac{\partial^2 W}{\partial x^2} \quad \frac{\partial^2 W}{\partial y^2} \quad \frac{\partial^2 W}{\partial x \partial y} \right] \quad (37)$$

$$H = \begin{bmatrix} H_{SS} & | & 0 \\ \hline (3 \times 4) & | & (3 \times 7) \\ 0 & | & H_{BB} \\ \hline (6 \times 4) & | & (6 \times 7) \end{bmatrix} \quad (38)$$

$$H_{SS} = \begin{bmatrix} 1 & 0 & 0 & 0 \\ 0 & 0 & 0 & 1 \\ 0 & 1 & 1 & 0 \end{bmatrix} \quad (39)$$

$$H_{BB} = \begin{bmatrix} 5/4 & 0 & 0 & 0 & 1/4 & 0 & 0 \\ 0 & 5/4 & 0 & 0 & 0 & 1/4 & 0 \\ 0 & 0 & 5/4 & 5/4 & 0 & 0 & 1/2 \\ -5/3h^2 & 0 & 0 & 0 & -5/3h^2 & 0 & 0 \\ 0 & -5/3h^2 & 0 & 0 & 0 & -5/3h^2 & 0 \\ 0 & 0 & -5/3h^2 & -5/3h^2 & 0 & 0 & -10/3h^2 \end{bmatrix} \quad (40)$$

where 0 is a null matrix.

Equations (21), (22), and (34) yield

$$\begin{matrix} N & = & I & H & \psi \\ (3 \times 1) & & (3 \times 9) & (9 \times 11) & (11 \times 1) \end{matrix} \quad (41)$$

$$\begin{matrix} M & = & J & H & \psi \\ (3 \times 1) & & (3 \times 9) & (9 \times 11) & (11 \times 1) \end{matrix} \quad (42)$$

By using the strain-displacement relations and equations (5), (6), (7), (10), (17), (18), (19), and (20), equation (2) yields on integration through the thickness

$$Q = \begin{Bmatrix} Q_x \\ Q_y \end{Bmatrix} = [R] \begin{Bmatrix} \beta_x \\ \beta_y \\ \partial W / \partial x \\ \partial W / \partial y \end{Bmatrix} \quad (43)$$

where

$$R = \begin{matrix} [\alpha] \\ (2 \times 4) \end{matrix} \begin{bmatrix} 5/4 & 0 & 1/4 & 0 \\ -5/3h^2 & 0 & -5/3h^2 & 0 \\ 0 & 5/4 & 0 & 1/4 \\ 0 & -5/3h^2 & 0 & -5/3h^2 \end{bmatrix} + \begin{bmatrix} 0 & 0 & | & T \\ 0 & 0 & | & (2 \times 2) \end{bmatrix} \quad (44)$$

$$\alpha = \int_{-h/2}^{h/2} \begin{bmatrix} C_{55} & 3C_{55}z^2 & C_{56} & 3C_{56}z^2 \\ C_{56} & 3C_{56}z^2 & C_{66} & 3C_{66}z^2 \end{bmatrix} dz \quad (45)$$

$$\tau = \int_{-h/2}^{h/2} \begin{bmatrix} C_{55} & C_{56} \\ C_{56} & C_{66} \end{bmatrix} dz \quad (46)$$

Equations (41) to (43) are the constitutive equations for a general, unsymmetric laminate with stretching-bending coupling. These equations define the force and moment stress resultants in terms of average inplane displacements U and V , normal deflection W , and average rotations of a line normal to the middle surface β_x and β_y . The governing equations can be derived by substituting from these constitutive equations into the equilibrium equations. Because they are lengthy and cumbersome, they are not shown herein. Derivation of the governing equation is carried out here only for the symmetric laminate case, in which there is no coupling between stretching and bending.

Symmetric Laminate Under Bending

For a symmetric laminate, the matrices L_{SB} and L_{BS} which couple stretching and bending become null matrices. Consequently, the constitutive equation (42) for moments simplifies to

$$\begin{matrix} M \\ (3 \times 1) \end{matrix} = \begin{matrix} L_{BB} \\ (3 \times 6) \end{matrix} \begin{matrix} H_{BB} \\ (6 \times 7) \end{matrix} \begin{matrix} \phi_B \\ (7 \times 1) \end{matrix} \quad (47)$$

where the various matrices appearing on the right-hand side of equation (47) are defined by equations (28), (29), (37), and (40). The constitutive equation (43) for transverse shear forces is not simplified. Further treatment of symmetric laminates herein is confined to derivation of relations pertaining to bending. The stretching relations become identical with those from classical lamination theory and need no separate treatment.

The moment and force equilibrium equations for the laminate under bending are

$$\partial M_x / \partial x + \partial M_{xy} / \partial y = Q_x \quad (48)$$

$$\partial M_{xy}/\partial x + \partial M_y/\partial y = Q_y \quad (49)$$

$$\partial Q_x/\partial x + \partial Q_y/\partial y = -q \quad (50)$$

On substitution from the constitutive equations (43) and (47), equations (48) to (50) yield three governing equations for three unknowns; namely, W , β_x , and β_y . These can be reduced to a single equation in terms of W by eliminating β_x and β_y , as follows:

Equation (43) can be rewritten as

$$\begin{Bmatrix} \beta_x \\ \beta_y \end{Bmatrix} = [P] \begin{Bmatrix} \partial W/\partial x \\ \partial W/\partial y \\ Q_x \\ Q_y \end{Bmatrix} \quad (51)$$

(2x4)

where

$$[P] = \left[\begin{array}{cc|cc} -\xi^{-1} & \eta & & \\ & & \xi^{-1} & \end{array} \right] \quad (52)$$

The $[\xi]$ and $[\eta]$ in equation (52) are 2×2 submatrices obtained by partitioning the 2×4 matrix $[R]$ of equation (44) as

$$R = \left[\begin{array}{cc|cc} \xi & & \eta & \\ \hline (2 \times 2) & & (2 \times 2) & \end{array} \right] \quad (53)$$

A column matrix Ω is now defined as

$$\Omega^T = \left[\begin{array}{ccccccc} \frac{\partial^2 W}{\partial x^2} & \frac{\partial^2 W}{\partial y^2} & \frac{\partial^2 W}{\partial x \partial y} & \frac{\partial Q_x}{\partial x} & \frac{\partial Q_x}{\partial y} & \frac{\partial Q_y}{\partial x} & \frac{\partial Q_y}{\partial y} \end{array} \right] \quad (54)$$

From equation (51), a relationship between the column matrices ψ_B and Ω is found as

$$\begin{matrix} \psi_B \\ (7 \times 1) \end{matrix} = \begin{matrix} \Gamma \\ (7 \times 7) \end{matrix} \begin{matrix} \Omega \\ (7 \times 1) \end{matrix} \quad (55)$$

where

$$\Gamma = \begin{bmatrix} P_{11} & 0 & P_{12} & P_{13} & 0 & P_{14} & 0 \\ 0 & P_{22} & P_{21} & 0 & P_{23} & 0 & P_{24} \\ 0 & P_{12} & P_{11} & 0 & P_{13} & 0 & P_{14} \\ P_{21} & 0 & P_{22} & P_{23} & 0 & P_{24} & 0 \\ 1 & 0 & 0 & 0 & 0 & 0 & 0 \\ 0 & 1 & 0 & 0 & 0 & 0 & 0 \\ 0 & 0 & 1 & 0 & 0 & 0 & 0 \end{bmatrix}$$

The elements P_{ij} in the foregoing equation are the elements of the [P] matrix obtained from equation (52). By using equation (55), equation (47) is reduced to

$$M = \theta \Omega \quad (56)$$

$(3 \times 1) \quad (3 \times 7) \quad (7 \times 1)$

where

$$\theta = \begin{matrix} L_{BB} & H_{BB} & \Gamma \\ (3 \times 6) & (6 \times 7) & (7 \times 7) \end{matrix} \quad (57)$$

By using equation (56), the moment equilibrium equations (48) and (49) become

$$\Delta_1 Q_x - \Delta_2 Q_y = \Delta_3 W \quad (58)$$

$$-\Delta_4 Q_x + \Delta_5 Q_y = \Delta_6 W \quad (59)$$

Here, Δ_1 to Δ_6 are linear differential operators, the coefficients of which are defined in terms of elements of the matrix θ . Equations (58) and (59) yield

$$\Delta_7 Q_x = (\Delta_3 \Delta_5 + \Delta_2 \Delta_6) W \quad (60)$$

$$\Delta_7 Q_y = (\Delta_1 \Delta_6 + \Delta_3 \Delta_4) W \quad (61)$$

where

$$\Delta_7 = (\Delta_1 \Delta_5 - \Delta_2 \Delta_4) \quad (62)$$

Elimination of Q_x and Q_y from equations (50), (60), and (61) results in

$$\begin{aligned} \sum_{i=0,1,2,\dots}^4 a_{(4-i)i} \frac{\partial^4 W}{\partial x^{(4-i)} \partial y^i} + \sum_{i=0,1,2,\dots}^6 a_{(6-i)i} \frac{\partial^6 W}{\partial x^{(6-i)} \partial y^i} \\ = -q + b_{20} \frac{\partial^2 q}{\partial x^2} + b_{11} \frac{\partial^2 q}{\partial x \partial y} + b_{02} \frac{\partial^2 q}{\partial y^2} \\ + \sum_{i=0,1,2,\dots}^4 b_{(4-i)i} \frac{\partial^4 q}{\partial x^{(4-i)} \partial y^i} \quad (63) \end{aligned}$$

where the coefficients a and b are derived in appendix B in terms of elements of the matrix θ . The convention followed for the subscripts on a and b in equation (63) is that the two subscripts (the first one being in parentheses) are not to be multiplied with each other but written adjacent to each other. For example, $a_{(6-i)i}$ for $i = 1$ is a_{51} .

Equation (63) is a sixth-order governing equation for the normal displacement. It permits the three natural physical boundary conditions to be prescribed over each boundary as in Reissner's (ref. 8) or Mindlin's (ref. 7) theory for isotropic plates. Once W is determined from equation (63) and the prescribed boundary conditions, all the other physical quantities can be determined in terms of W . To this end, the transverse shear forces are found through equations (58) and (59), moments through the matrix equation (56), and rotations through equation (51).

Symmetric Cross-Ply Laminate Under Bending

The constitutive equations for an unsymmetric laminate and a general symmetric laminate were derived in matrix form so that the coefficients appearing in them could be calculated routinely with matrix algebra. The special case of a symmetric cross ply is now considered. A symmetric cross-ply laminate is defined as one which is comprised of only 0° and 90° layers stacked symmetrically with respect to the middle surface. In this case, there is no coupling between bending and twisting, and the matrix relations derived previously for a general symmetric laminate reduce to simple formulas. These formulas are now derived.

For convenience, the x - and y -axes (fig. 1) are chosen to be oriented along the principal axes of the laminate. Thus

$$C_{13} = C_{23} = C_{34} = 0 \quad (64)$$

$$C_{56} = 0 \quad (65)$$

and consequently some elements of the reduced stiffness matrix also vanish; thus

$$\bar{C}_{13} = \bar{C}_{23} = 0 \quad (66)$$

By using equations (65) and (66), equations (47) and (43) reduce to

$$M_x = D_{11} \frac{\partial \beta_x}{\partial x} + D_{12} \frac{\partial \beta_y}{\partial y} + A_{11} \frac{\partial^2 W}{\partial x^2} + A_{12} \frac{\partial^2 W}{\partial y^2} \quad (67)$$

$$M_y = D_{12} \frac{\partial \beta_x}{\partial x} + D_{22} \frac{\partial \beta_y}{\partial y} + A_{12} \frac{\partial^2 W}{\partial x^2} + A_{22} \frac{\partial^2 W}{\partial y^2} \quad (68)$$

$$M_{xy} = D_{33} \left(\frac{\partial \beta_x}{\partial y} + \frac{\partial \beta_y}{\partial x} \right) + 2A_{33} \frac{\partial^2 W}{\partial x \partial y} \quad (69)$$

$$Q_x = K_1 \left(\beta_x + \frac{\partial W}{\partial x} \right) \quad (70)$$

$$Q_y = K_2 \left(\beta_y + \frac{\partial W}{\partial y} \right) \quad (71)$$

where

$$D_{ij} = \frac{5}{4} \bar{C}_{ij}^{(2)} - \frac{5}{3h^2} \bar{C}_{ij}^{(4)} \quad (72)$$

$$A_{ij} = \frac{1}{4} \bar{C}_{ij}^{(2)} - \frac{5}{3h^2} \bar{C}_{ij}^{(4)} \quad (73)$$

$$K_1 = \frac{5}{4} \int_{-h/2}^{h/2} C_{55} \left[1 - (2z/h)^2 \right] dz \quad (74)$$

$$K_2 = \frac{5}{4} \int_{-h/2}^{h/2} C_{66} \left[1 - (2z/h)^2 \right] dz \quad (75)$$

Here D_{ij} can be interpreted as anisotropic plate bending rigidities. As shown subsequently, they become equal to the isotropic values for the limiting case of isotropy. The coefficients A_{ij} vanish for the isotropic case and might therefore be referred to as anisotropic "differential" plate bending rigidities.

Substituting from equations (70) and (71) into equations (67) to (69) and using equation (50) yields

$$M_x = -\bar{C}_{11}^{(2)} \frac{\partial^2 W}{\partial x^2} - \bar{C}_{12}^{(2)} \frac{\partial^2 W}{\partial y^2} + \left(\frac{D_{11}}{K_1} - \frac{D_{12}}{K_2} \right) \frac{\partial Q_x}{\partial x} - \frac{D_{12}}{K_2} q \quad (76)$$

$$M_y = -\bar{C}_{12}^{(2)} \frac{\partial^2 W}{\partial x^2} - \bar{C}_{22}^{(2)} \frac{\partial^2 W}{\partial y^2} + \left(\frac{D_{22}}{K_2} - \frac{D_{12}}{K_1} \right) \frac{\partial Q_y}{\partial y} - \frac{D_{12}}{K_1} q \quad (77)$$

$$M_{xy} = -2\bar{C}_{33}^{(2)} \frac{\partial^2 W}{\partial x \partial y} + D_{33} \left(\frac{1}{K_1} \frac{\partial Q_x}{\partial y} + \frac{1}{K_2} \frac{\partial Q_y}{\partial x} \right) \quad (78)$$

Equations (67) to (69) and (76) to (78) are two alternate forms of constitutive equations for moments for a symmetric cross-ply laminate. Equations (70) and (71) are the constitutive equations for transverse shear forces.

By using equations (50), (76), (77), and (78), the moment equilibrium equations (48) and (49) can be written as

$$\Delta_8 Q_x = -\Delta_{10} W - c_1 \frac{\partial q}{\partial x} \quad (79)$$

$$\Delta_9 Q_y = -\Delta_{11} W - c_2 \frac{\partial q}{\partial y} \quad (80)$$

where Δ_8 to Δ_{11} are linear differential operators defined by

$$\Delta_8 = () + d_1 \partial^2 () / \partial x^2 + d_2 \partial^2 () / \partial y^2 \quad (81)$$

$$\Delta_9 = () + d_3 \partial^2 () / \partial x^2 + d_4 \partial^2 () / \partial y^2 \quad (82)$$

$$\Delta_{10} = e_1 \partial^3 () / \partial x^3 + e_2 \partial^3 () / \partial x \partial y^2 \quad (83)$$

$$\Delta_{11} = e_2 \partial^3 () / \partial x^2 \partial y + e_3 \partial^3 () / \partial y^3 \quad (84)$$

$$d_1 = \frac{1}{K_2} (D_{12} + D_{33}) - \frac{D_{11}}{K_1} \quad (85)$$

$$d_2 = -D_{33}/K_1 \quad (86)$$

$$d_3 = -D_{33}/K_2 \quad (87)$$

$$d_4 = \frac{1}{K_1}(D_{12} + D_{33}) - \frac{D_{22}}{K_2} \quad (88)$$

$$e_1 = \bar{C}_{11}^{(2)} \quad (89)$$

$$e_2 = \bar{C}_{12}^{(2)} + 2\bar{C}_{33}^{(2)} \quad (90)$$

$$e_3 = \bar{C}_{22}^{(2)} \quad (91)$$

$$c_1 = \frac{1}{K_2}(D_{12} + D_{33}) \quad (92)$$

$$c_2 = \frac{1}{K_1}(D_{12} + D_{33}) \quad (93)$$

Elimination of Q_x and Q_y from equations (50), (79), and (80) results in the governing equation for W as

$$\Delta_9 \Delta_{10} (\partial W / \partial x) + \Delta_8 \Delta_{11} (\partial W / \partial y) = \Delta_8 \Delta_9 q - c_1 \Delta_9 (\partial^2 q / \partial x^2) - c_2 \Delta_8 (\partial^2 q / \partial y^2) \quad (94)$$

By substituting for the differential operators, equation (94) becomes

$$\begin{aligned}
& e_1 \frac{\partial^4 w}{\partial x^4} + 2e_2 \frac{\partial^4 w}{\partial x^2 \partial y^2} + e_3 \frac{\partial^4 w}{\partial y^4} + d_3 e_1 \frac{\partial^6 w}{\partial x^6} + \left[e_2 (d_1 + d_3) + d_4 e_1 \right] \frac{\partial^6 w}{\partial x^4 \partial y^2} \\
& + \left[d_1 e_3 + e_2 (d_2 + d_4) \right] \frac{\partial^6 w}{\partial x^2 \partial y^4} + d_2 e_3 \frac{\partial^6 w}{\partial y^6} \\
& = q + (d_1 + d_3 - c_1) \frac{\partial^2 q}{\partial x^2} + (d_2 + d_4 - c_2) \frac{\partial^2 q}{\partial y^2} \\
& + d_3 (d_1 - c_1) \frac{\partial^4 q}{\partial x^4} + \left[d_1 (d_4 - c_2) + d_2 d_3 - d_4 c_1 \right] \frac{\partial^4 q}{\partial x^2 \partial y^2} \\
& + d_2 (d_4 - c_2) \frac{\partial^4 q}{\partial y^4} \tag{95}
\end{aligned}$$

Equation (95) has no derivative involving odd number of differentiations with respect to x or y . In contrast, these derivatives appear in the governing equation (63) for a general symmetric laminate.

Reduction to Isotropic Plate Relations

For the special case of isotropy

$$\bar{C}_{11} = \bar{C}_{22} = E/(1 - \nu^2) \tag{96}$$

$$\bar{C}_{12} = \nu E/(1 - \nu^2) \tag{97}$$

$$D_{11} = D_{22} = \bar{C}_{11}^{(2)} = \bar{C}_{22}^{(2)} = \text{Plate bending rigidity, } D = \frac{Eh^3}{12(1 - \nu^2)} \tag{98}$$

$$D_{12} = \bar{C}_{12}^{(2)} = \nu D \tag{99}$$

$$D_{33} = \bar{C}_{33}^{(2)} = (1 - \nu)D/2 \tag{100}$$

$$A_{11} = A_{22} = A_{12} = 0 \quad (101)$$

$$K_1 = K_2 = \frac{5}{6} Gh \quad (102)$$

By using equations (96) to (102), the constitutive equations (67) to (71) and (76) to (78) reduce to a form similar to Reissner's (ref. 8). The only discrepancy involves terms of q . For the homogeneous case $q = 0$, the two theories are identical. The discrepancy for $q \neq 0$ vanishes if the contribution from σ_z to strain energy is neglected in Reissner's energy formulation (ref. 8). As this contribution is relatively small, the discrepancy between the two theories can be considered to be a higher order effect and negligible.

The discrepancy in terms involving q is a consequence of the assumption of constant w through thickness in the present theory. Reissner's isotropic plate theory is based on exact satisfaction of the equilibrium equation in the z -direction for all z which implies variation of w with z .

DISCUSSION

A sixth-order governing equation for W is obtained here for a symmetric laminate. This is in contrast to the Reissner (ref. 8) and Mindlin (ref. 7) theories for an isotropic plate which give a fourth-order equation for W together with an auxiliary equation of second order for a transverse shear function χ . However, the total order is the same in both cases, thereby requiring prescription of the same number of boundary conditions.

A close inspection reveals that, for the limiting case of isotropy, the present theory also leads to lower order equations for W and χ like the Reissner (ref. 8) and Mindlin (ref. 7) theories. This happens because, for isotropy, the differential operators Δ_8 and Δ_9 in equations (79) and (80) become identical. Thus, fewer differentiations would be required to eliminate Q_x and Q_y from equations (50), (79), and (80). (See derivation of eq. (94).)

The Q_x and Q_y for a laminated plate are determined completely in terms of W as particular integrals of equations (79) and (80). Complementary solutions of these equations are not admissible as they violate the equilibrium equation (50). Recall that, in contrast, complementary solutions are used in isotropic plates (refs. 7 and 8) because complementary solutions in the isotropic case can be chosen to satisfy the equilibrium equation (50).

Shear Correction Factor

The term "shear correction factor" in transverse shear deformation theories is usually meant to refer to an arbitrary correction applied to the shear stiffness previously determined. In the present theory, there is no shear correction factor in this sense of the term because the transverse shear stiffness is explicitly determined and no correction is necessary. This

becomes clear by examining the limiting case of isotropy in detail. From equations (70), (71), and (102), transverse shear forces for an isotropic plate are given by

$$Q_x = \frac{5}{6} Gh \left(\beta_x + \frac{\partial W}{\partial x} \right) \quad (103)$$

$$Q_y = \frac{5}{6} Gh \left(\beta_y + \frac{\partial W}{\partial y} \right) \quad (104)$$

where G is the isotropic shear modulus. Equations (103) and (104) agree with the results from Reissner's theory for isotropic plates (ref. 8).

The quantities $\beta_x + \frac{\partial W}{\partial x}$ and $\beta_y + \frac{\partial W}{\partial y}$ represent average shear strains through the thickness. Thus, the factor $5/6$ (0.833) in equations (103) and (104) can be looked upon as a correction to be applied to the transverse shear stiffness to account for variation of shear stress through the thickness. In Mindlin's theory (ref. 7), the assumption of constant shear strain led to a factor of unity instead of $5/6$ (0.833) in equations (103) and (104). However, Mindlin replaced this factor of unity by an arbitrary factor, the value of which was adjusted so that results from the theory agreed with the exact solution for a chosen example. He arrived at a value of $\pi^2/12$ (0.822) for this factor by considering one example. By considering a second example, he obtained another value which depends on Poisson's ratio ν and varies from 0.76 to 0.91 as ν varies from 0 to 0.5. The first value $\pi^2/12$ (0.822) is close to $5/6$ (0.833) obtained from Reissner's theory. However, the manner in which the shear correction factor is derived in Mindlin's approach is arbitrary because the value arrived at depends on the example chosen. The present theory is also based on a displacement formulation similar to Mindlin's but the shear correction is derived in a logical way. Thus, the present theory can be looked upon as an improvement of Mindlin's theory for isotropic plates.

Straightforward extensions of Mindlin's theory to laminated composite plates (refs. 3 to 5) have the same degree of arbitrariness as Mindlin's theory itself. For instance, Whitney and Pagano (ref. 4) arrived at different shear correction factors for two-layered and three-layered plates. The suggested procedure in their method appears to be to derive the shear correction factor for each set of lamination parameters by considering the known exact solution for a certain problem. But with the present theory, no shear correction factor is necessary and the transverse shear stiffness is obtained as a function of elastic constants and the stacking sequence without considering the exact solution for a specific problem. The required expressions are given by equations (74) and (75).

Interlaminar Shear Stresses

Interlaminar shear is one of the sources of failure in laminated plates. Therefore, calculation of interlaminar shear stresses is important in any bending problem. With the use of the present theory, these stresses can be calculated as follows: A problem is considered solved if β_x , β_y , and W are determined as functions of x and y . The displacements can be determined as functions of x , y , and z by the use of equations (10), (17) to (20), and (5) to (7). Thus, σ_x , σ_y , and τ_{xy} are also determined as functions of x , y , and z from the constitutive relations of individual laminae. The interlaminar shear stresses are then determined from the following equilibrium equations:

$$\tau_{xz} = \int_{-h/2}^z \left(\frac{\partial \sigma_x}{\partial x} + \frac{\partial \tau_{xy}}{\partial y} \right) dz$$

$$\tau_{yz} = \int_{-h/2}^z \left(\frac{\partial \tau_{xy}}{\partial x} + \frac{\partial \sigma_y}{\partial y} \right) dz$$

This method gives single-valued interlaminar shear stresses at the interfaces. An alternate method would be to calculate τ_{xz} and τ_{yz} directly from the displacements given by equations (5) to (7). However, this method gives two values for the interlaminar shear stress at each interface depending upon the lamina chosen.

NUMERICAL EXAMPLE

A numerical example is used to compare the present theory with the existing theories. The example chosen is that of cylindrical bending of a three-layered, symmetric cross-ply laminate ($0^\circ/90^\circ/0^\circ$) of high modulus graphite-epoxy. The layers are all taken to be of equal thickness with fibers in the outer layers oriented in the direction of bending (fig. 2). The layer properties used are

$$E_{\lambda t} / E_t = 25$$

$$G_{\lambda t} / E_t = 0.5$$

$$G_{tt} / E_t = 0.2$$

$$\nu_{\lambda t} = \nu_{tt} = 0.25$$

The plate is considered to be semi-infinite with a finite span s in the x -direction (fig. 2) and subjected to a sinusoidal, distributed normal load of intensity $q = q_{\max} \sin \frac{\pi x}{s}$. The boundary conditions considered are

At $x = 0$ and s ,

$$W = \beta_y = M_x = 0 \quad (105)$$

For the case of cylindrical bending, all derivatives with respect to y are zero. Thus equation (95) yields

$$W = W_{\max} \sin \frac{\pi x}{s} \quad (106)$$

where

$$W_{\max} = q_{\max} \frac{1 + (c_1 - d_1 - d_3)(\pi/s)^2 + d_3(d_1 - c_1)(\pi/s)^4}{e_1(\pi/s)^4 \left[1 - d_3(\pi/s)^2 \right]} \quad (107)$$

The transverse shear force Q_x is obtained from equation (79) as

$$Q_x = Q_{x,\max} \cos \frac{\pi x}{s} \quad (108)$$

where

$$Q_{x,\max} = \frac{(\pi/s)^3 e_1 W_{\max} - (\pi/s) c_1 q_{\max}}{1 - (\pi/s)^2 d_1} \quad (109)$$

Equation (70) yields the rotation β_x as

$$\beta_x = \beta_{x,\max} \cos \frac{\pi x}{s} \quad (110)$$

where

$$\beta_{x, \max} = \frac{1}{K_1} Q_{x, \max} - (\pi/s) W_{\max} \quad (111)$$

From equations (80) and (71) and the boundary condition on β_y

$$Q_y \equiv 0 \quad \beta_y \equiv 0 \quad (112)$$

Stresses in the different laminae are now determined as follows. In pure bending, the terms u_0 and v_0 in equations (5) and (6) vanish. Consequently, the inplane displacements u and v are defined, in view of equation (10), by

$$u = u_1 z + u_3 z^3 \quad (113)$$

$$v = v_1 z + v_3 z^3 \quad (114)$$

The u_1 and u_3 are determined from equations (17) and (18). It follows from equations (19), (20), (106), (107), and (112) that v_1 and v_3 are zero. The inplane displacements are thus determined. Bending stress distribution through the thickness is now determined from the constitutive relations of different laminae.

Exact solution for this problem based on three-dimensional elasticity analysis was given by Pagano (ref. 9). Figures 3 and 4 compare results from the present theory with those from the exact solution and the theory of Whitney and Pagano (ref. 4). The theories presented in references 3 to 5 are all a simplified set requiring an arbitrary shear correction factor. In the results presented in these references, the value of the shear correction factor is adjusted so that the results come close to the exact solution. Therefore a comparison of results from all these theories could be misleading. For this purpose, only Whitney and Pagano's theory (ref. 4) is chosen for comparison and is treated as being representative of the simplified theories (refs. 3 to 5).

Figure 3 shows a plot of the maximum deflection W_{\max} at the center of the span as a function of the span-to-thickness ratio. The present theory is closer to the exact solution than Whitney and Pagano's theory (ref. 4) with a shear correction factor k of unity. On the other hand, Whitney and Pagano's theory shows better correlation if k is shown as 2/3. However, the factor 2/3 was arrived at by Whitney and Pagano by a trial-and-error procedure. There are two disadvantages in Whitney and Pagano's method. First, the trial-and-error procedure is to be repeated if the lamination parameters are different.

There is no single value of k which holds good for all lamination parameters. (For example, Whitney and Pagano arrived at another value for k , namely, $5/6$, for a two-layered plate.) Secondly, the shear correction factor arrived at by this procedure is problem-dependent and it is not sure whether the value for k so derived is valid for a problem other than cylindrical bending. Recall that Mindlin (ref. 7) arrived at different values for k by considering different problems.

Figure 4 presents the bending stress σ_x distribution through the thickness for a laminate with a span-to-thickness ratio s/h of 4. The exact solution of Pagano (ref. 9) and results from Whitney and Pagano's theory and the present theory are presented in this figure. Results from the classical laminated plate theory are also included for comparison. The exact solution and the present theory show considerable deviation from the classical theory. Furthermore, the exact solution and the present theory are in good agreement for most of the thickness. Note that in the middle layer, the 90° lamina, the stresses σ_x are extremely small and all theories predict near zero values.

Figure 4 shows that Whitney and Pagano's theory (ref. 4) yields the same stress distribution as the classical laminated plate theory irrespective of the value of the shear correction factor used. This is true of all current sixth-order theories for laminated anisotropic plates (refs. 3 to 6). The fact that these theories predict stresses no different from the classical theory is a severe limitation. Even Cohen's theory (ref. 6), which predicts W with good accuracy without a shear correction factor, has this drawback. A careful inspection reveals that this drawback in current sixth-order bending theories is a consequence of the assumption of linearity of ϵ_x , ϵ_y , and γ_{xy} with respect to z . The present theory allows for a more general variation of these strains with respect to z and does not have this drawback.

CONCLUDING REMARKS

A shear deformation theory for laminated anisotropic plates is developed. In the case of uncoupled bending, the present theory is one of sixth order and requires just three natural boundary conditions. Most of the current sixth-order theories require an arbitrary shear correction factor and all of them have the drawback that their stress prediction is highly inaccurate. The present theory does not have either of these drawbacks.

The present theory is not presented as an improvement over the current higher order theories. Surely, they should be more accurate but they require prescription of inconvenient boundary conditions. From the engineering point of view, it is difficult to prescribe anything other than the three natural boundary conditions involving moments and forces or the corresponding rotations and displacements. Consequently, a sixth-order bending theory which requires the three boundary conditions is desirable. This paper was aimed at developing the best possible theory restricting the order of the theory to six.

The theory is developed for three cases. First, the formulation is carried out for an unsymmetric laminate. Here, the constitutive equations connecting moments and forces to average displacements and rotations are derived.

Second, simplified forms of these constitutive equations are derived for a symmetric laminate. In both these cases, the various relations are derived in matrix form to avoid tedious algebra and also to facilitate routine computation on a computer. Last, further simplified relations are derived for a symmetric cross ply which is a case of classical orthotropy. In this case, it was found that matrix formulation could be dispensed with and the various relations are obtained in the form of simple formulas.

For the limiting case of isotropy, the present theory reduces to an improved version of Mindlin's theory. The shear correction factor of $5/6$ in this case is obtained from the theory rather than with a specific example as in Mindlin's approach.

Of particular interest should be the method of computing the interlaminar shear stress suggested in this paper. The use of equilibrium equations leads to single-valued shear stresses unlike straightforward computation from displacements.

The accuracy of the present theory is demonstrated by considering a numerical example of cylindrical bending of a three-layered plate.

Langley Research Center
National Aeronautics and Space Administration
Hampton, VA 23665
June 30, 1981

APPENDIX A

DEFINITION OF "AVERAGE" VALUES OF DISPLACEMENTS AND ROTATIONS

Let the displacements u and v be arbitrary functions of z . Let U and V represent average values of displacements and β_x and β_y represent average values of rotations. "Averaging" here means averaging through the thickness. Essentially, the deformed shape of a line normal to the middle surface is sought to be approximated by a straight line so that its deviation from the true deformed shape is minimum. To this end, the displacements u and v are expressed as $U + \beta_x z$ and $V + \beta_y z$, respectively. Then, the deviation from the true deformed shape is represented by the following integrals of squares of errors in determining u and v :

$$E_u = \int_{-h/2}^{h/2} (u - U - \beta_x z)^2 dz$$

$$E_v = \int_{-h/2}^{h/2} (v - V - \beta_y z)^2 dz$$

The best least square approximation is that which satisfies the conditions

$$\frac{\partial E_u}{\partial U} = \frac{\partial E_u}{\partial \beta_x} = \frac{\partial E_v}{\partial V} = \frac{\partial E_v}{\partial \beta_y} = 0 \quad (A1)$$

Equations (A1) yield the definitions given by equations (11) and (12). The definitions given by equations (11) and (12) are identical with those obtained by Timoshenko and Woinowsky-Krieger (ref. 10) from considerations of work done by the forces and moments. However, the derivation in reference 10 is valid only if the stress varies linearly through the thickness. The stress variation for a laminated plate can, at the best, be only piecewise linear. In such a case, it would be necessary to resort to a mathematical definition as given herein.

APPENDIX B

DERIVATION OF COEFFICIENTS IN THE GOVERNING EQUATION

FOR A SYMMETRIC LAMINATE

Elimination of Q_x and Q_y from equations (50), (60), and (61) results in

$$\left[\frac{\partial}{\partial x} (\Delta_3 \Delta_5 + \Delta_2 \Delta_6) + \frac{\partial}{\partial y} (\Delta_1 \Delta_6 + \Delta_3 \Delta_4) \right] w + \Delta_7 q = 0$$

By substituting for the differential operators Δ_1 to Δ_7 in terms of elements of the matrix $[\theta]$, the following expressions for coefficients in the governing equation (63) are obtained:

$$a_{60} = \theta_{16} \theta_{31} - \theta_{11} \theta_{36}$$

$$a_{51} = \theta_{11} \theta_{34} + \theta_{17} \theta_{31} + \theta_{16} (\theta_{21} + \theta_{33}) - \theta_{13} \theta_{36} - \theta_{14} \theta_{31} - \theta_{11} (\theta_{26} + \theta_{37})$$

$$\begin{aligned} a_{42} = & \theta_{31} \theta_{37} + \theta_{11} (\theta_{24} + \theta_{35}) + \theta_{16} (\theta_{23} + \theta_{32}) + \theta_{34} (\theta_{13} + \theta_{31}) \\ & + (\theta_{17} + \theta_{36}) (\theta_{21} + \theta_{33}) - \theta_{11} \theta_{27} - \theta_{14} (\theta_{21} + \theta_{33}) - \theta_{31} (\theta_{15} + \theta_{34}) \\ & - \theta_{36} (\theta_{12} + \theta_{33}) - (\theta_{13} + \theta_{31}) (\theta_{26} + \theta_{37}) \end{aligned}$$

$$\begin{aligned} a_{33} = & \theta_{11} \theta_{25} + \theta_{16} \theta_{22} + \theta_{34} (\theta_{12} + \theta_{33}) + \theta_{37} (\theta_{21} + \theta_{33}) \\ & + (\theta_{13} + \theta_{31}) (\theta_{24} + \theta_{35}) + (\theta_{17} + \theta_{36}) (\theta_{23} + \theta_{32}) - \theta_{31} \theta_{35} - \theta_{32} \theta_{36} \\ & - \theta_{14} (\theta_{23} + \theta_{32}) - \theta_{27} (\theta_{13} + \theta_{31}) - (\theta_{12} + \theta_{33}) (\theta_{26} + \theta_{37}) \\ & - (\theta_{15} + \theta_{34}) (\theta_{21} + \theta_{33}) \end{aligned}$$

APPENDIX B

$$\begin{aligned}
 a_{24} = & \theta_{32}\theta_{34} + \theta_{22}(\theta_{17} + \theta_{36}) + \theta_{25}(\theta_{13} + \theta_{31}) + \theta_{37}(\theta_{23} + \theta_{32}) \\
 & + (\theta_{12} + \theta_{33})(\theta_{24} + \theta_{35}) - \theta_{14}\theta_{22} - \theta_{27}(\theta_{12} + \theta_{33}) \\
 & - \theta_{32}(\theta_{26} + \theta_{37}) - \theta_{35}(\theta_{21} + \theta_{33}) - (\theta_{15} + \theta_{34})(\theta_{23} + \theta_{32})
 \end{aligned}$$

$$a_{15} = \theta_{24}\theta_{32} + \theta_{25}(\theta_{12} + \theta_{33}) + \theta_{22}(\theta_{37} - \theta_{15} - \theta_{34}) - \theta_{23}\theta_{35} - \theta_{27}\theta_{32}$$

$$a_{06} = \theta_{25}\theta_{32} - \theta_{22}\theta_{35}$$

$$a_{40} = \theta_{11}$$

$$a_{31} = \theta_{13} + 2\theta_{31}$$

$$a_{22} = \theta_{12} + \theta_{21} + 2\theta_{33}$$

$$a_{13} = \theta_{23} + 2\theta_{32}$$

$$a_{04} = \theta_{22}$$

$$b_{20} = \theta_{14} + \theta_{36}$$

$$b_{11} = \theta_{15} + \theta_{26} + \theta_{34} + \theta_{37}$$

$$b_{02} = \theta_{27} + \theta_{35}$$

$$b_{40} = \theta_{16}\theta_{34} - \theta_{14}\theta_{36}$$

APPENDIX B

$$b_{31} = \theta_{17}\theta_{34} + \theta_{16}(\theta_{24} + \theta_{35}) - \theta_{15}\theta_{36} - \theta_{14}(\theta_{26} + \theta_{37})$$

$$b_{22} = \theta_{16}\theta_{25} + \theta_{34}\theta_{37} + (\theta_{17} + \theta_{36})(\theta_{24} + \theta_{35}) \\ - \theta_{14}\theta_{27} - \theta_{35}\theta_{36} - (\theta_{15} + \theta_{34})(\theta_{26} + \theta_{37})$$

$$b_{13} = \theta_{24}\theta_{37} + \theta_{25}(\theta_{17} + \theta_{36}) - \theta_{26}\theta_{35} - \theta_{27}(\theta_{15} + \theta_{34})$$

$$b_{04} = \theta_{25}\theta_{37} - \theta_{27}\theta_{35}$$

REFERENCES

1. Reissner, E.: Note on the Effect of Transverse Shear Deformation in Laminated Anisotropic Plates. *Comput. Methods Appl. Mech. & Eng.*, vol. 20, no. 2, Nov. 1979, pp. 203-209.
2. Lo, K. H.; Christensen, R. M.; and Wu, E. M.: A High-Order Theory of Plate Deformation. Part 2: Laminated Plates. *Trans. ASME, Ser. E: J. Appl. Mech.*, vol. 44, no. 4, Dec. 1977, pp. 669-676.
3. Yang, P. Constance; Norris, Charles H.; and Stavsky, Yehuda: Elastic Wave Propagation in Heterogeneous Plates. *Int. J. Solids & Struct.*, vol. 2, no. 4, Oct. 1966, pp. 665-684.
4. Whitney, J. M.; and Pagano, N. J.: Shear Deformation in Heterogeneous Anisotropic Plates. *J. Appl. Mech.*, vol. 37, no. 4, Dec. 1970, pp. 1031-1036.
5. Chou, Pei Chi; and Carleone, Joseph: Transverse Shear in Laminated Plate Theories. *AIAA J.*, vol. 11, no. 9, Sept. 1973, pp. 1333-1336.
6. Cohen, Gerald A.: Transverse Shear Stiffness of Laminated Anisotropic Shells. *Comput. Methods Appl. Mech. & Eng.*, vol. 13, no. 2, Feb. 1978, pp. 205-220.
7. Mindlin, R. D.: Influence of Rotatory Inertia and Shear on Flexural Motions of Isotropic, Elastic Plates. *J. Appl. Mech.*, vol. 18, no. 1, Mar. 1951, pp. 31-38.
8. Reissner, Eric: The Effect of Transverse Shear Deformation on the Bending of Elastic Plates. *J. Appl. Mech.*, vol. 12, no. 2, June 1945, pp. A69-A77.
9. Pagano, N. J.: Exact Solutions for Composite Laminates in Cylindrical Bending. *J. Compos. Mater.*, vol. 3, July 1969, pp. 398-411.
10. Timoshenko, S.; and Woinowsky-Krieger, S.: *Theory of Plates and Shells*, Second ed. McGraw-Hill book Co., Inc., 1959, pp. 165-171.

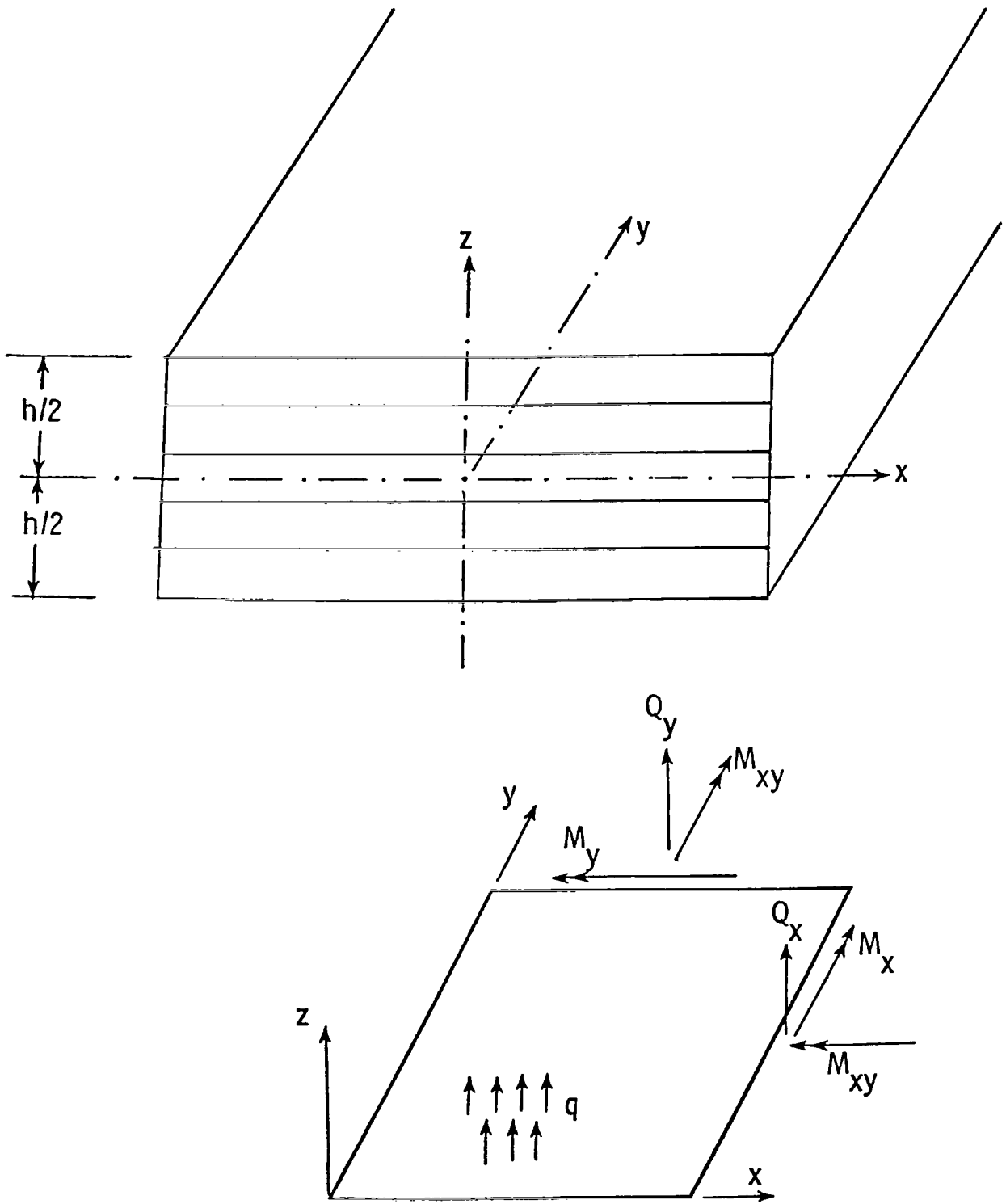

Figure 1.- System of coordinates and stress resultants.

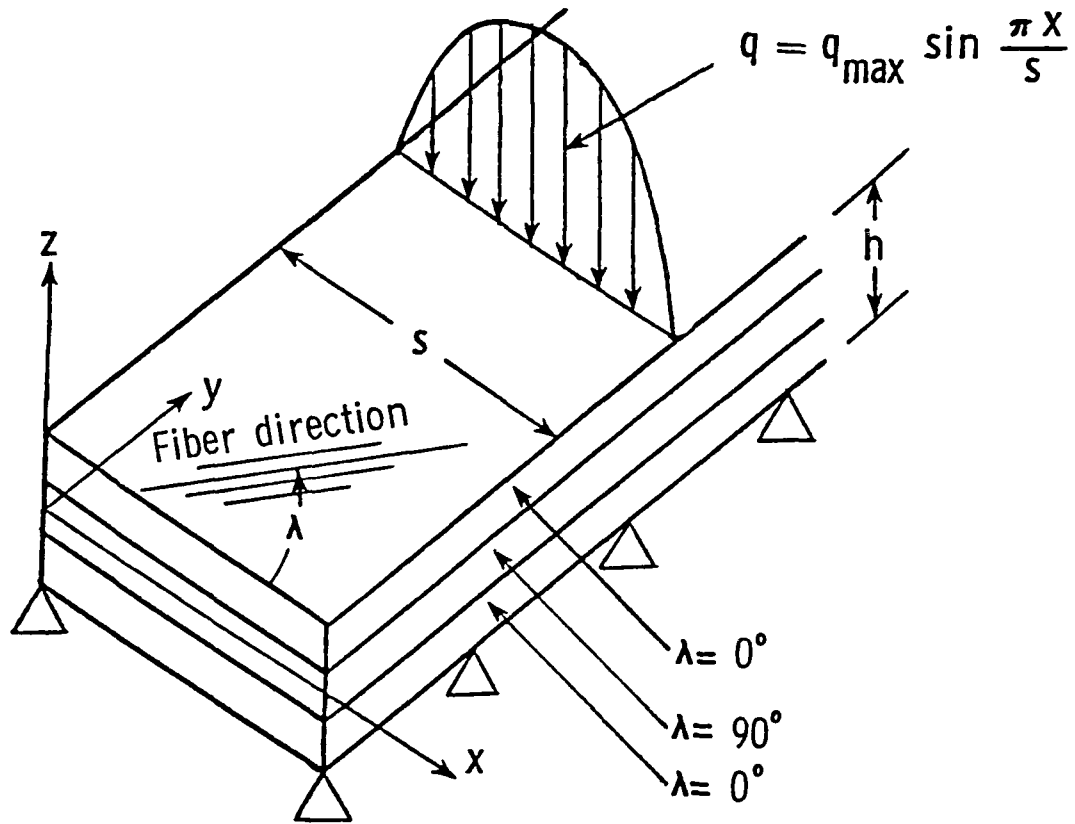

Figure 2.- Cylindrical bending of three-layered symmetric cross ply.

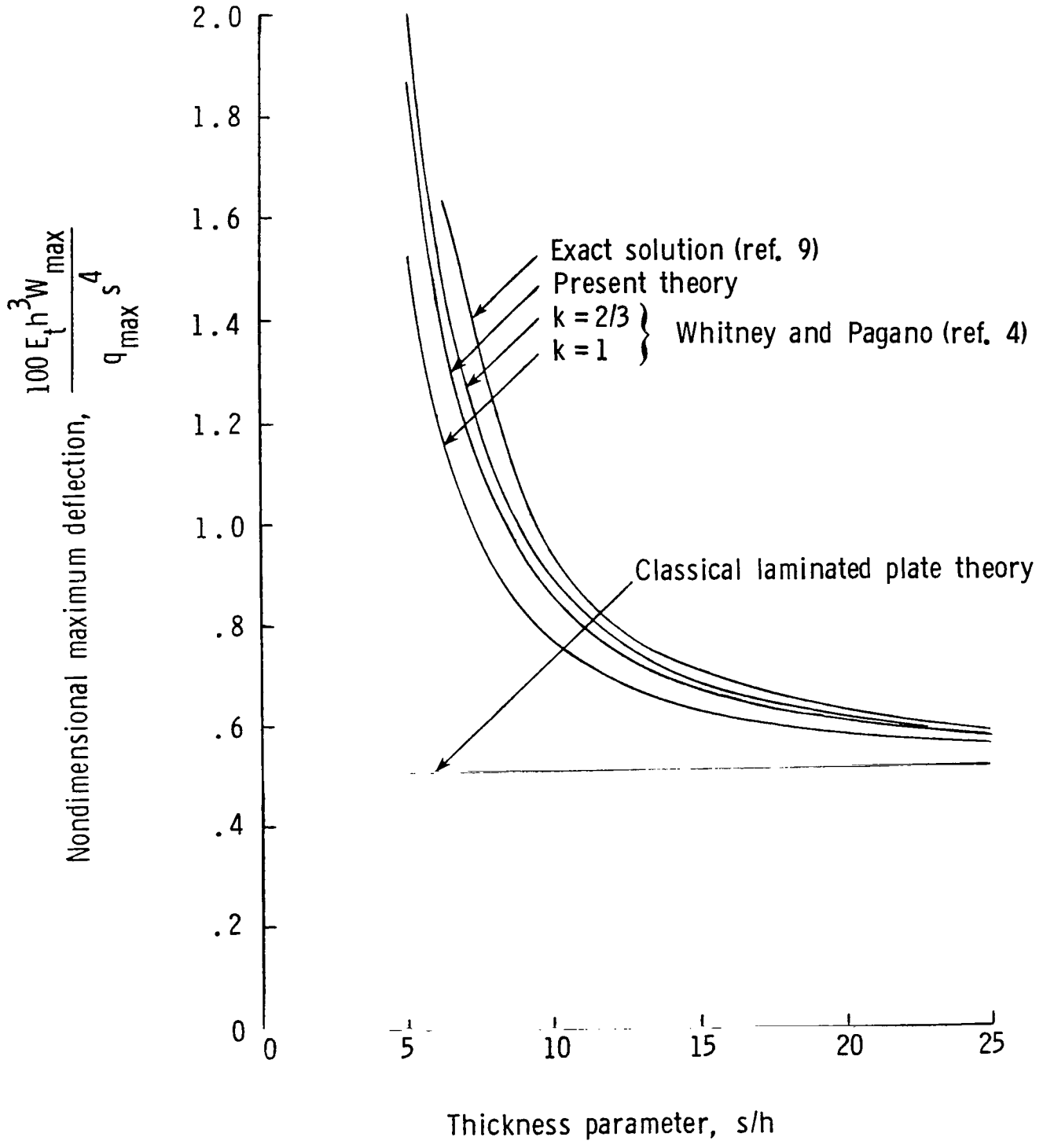

Figure 3.- Maximum deflection as function of thickness parameter.

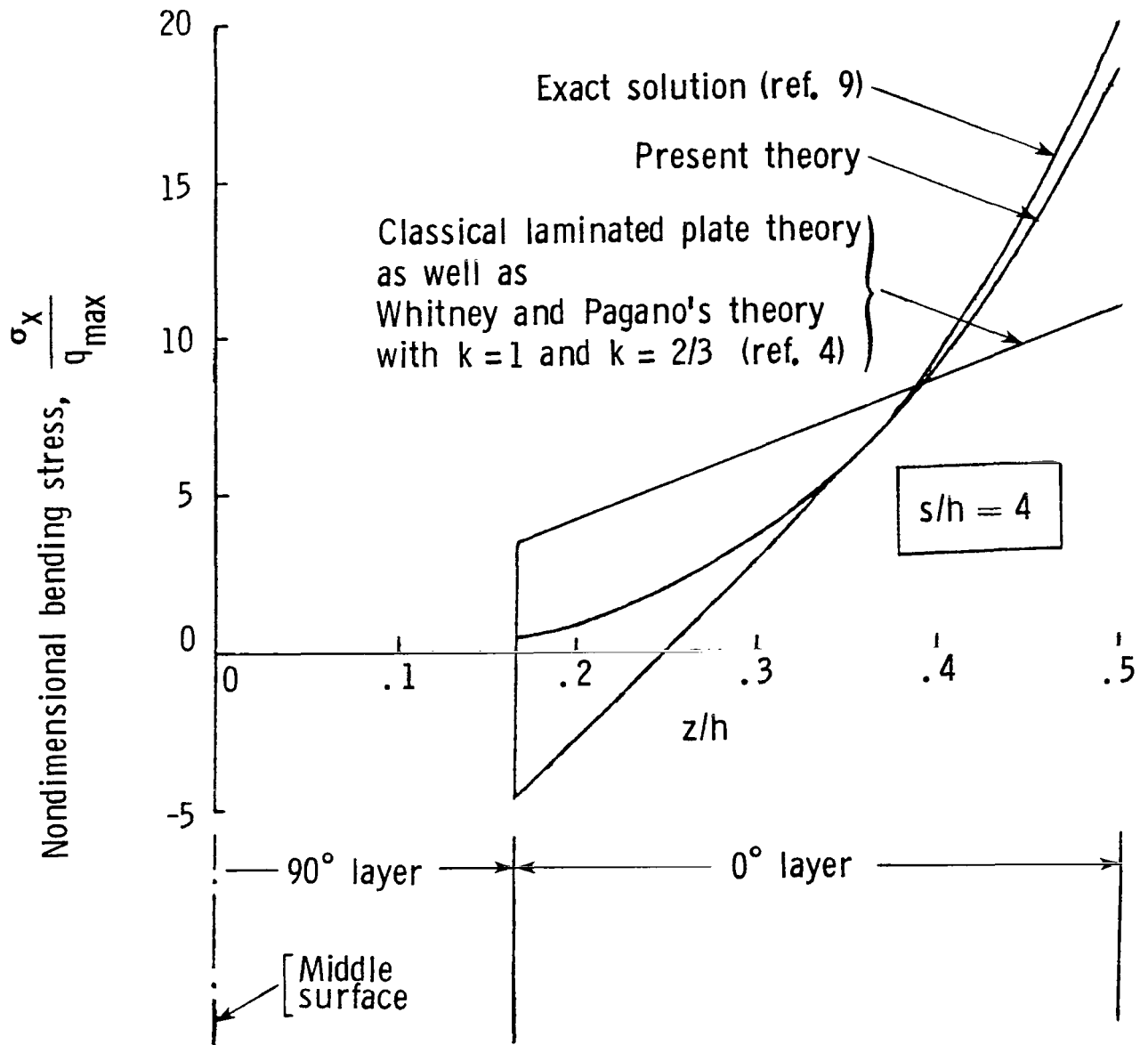

Figure 4.- Distribution of bending stress through thickness.

1. Report No. NASA TP-1903		2. Government Accession No.		3. Recipient's Catalog No.	
4. Title and Subtitle AN IMPROVED TRANSVERSE SHEAR DEFORMATION THEORY FOR LAMINATED ANISOTROPIC PLATES				5. Report Date November 1981	
7. Author(s) M. V. V. Murthy				6. Performing Organization Code 505-33-33-05	
9. Performing Organization Name and Address NASA Langley Research Center Hampton, VA 23665				8. Performing Organization Report No. L-14533	
12. Sponsoring Agency Name and Address National Aeronautics and Space Administration Washington, DC 20546				10. Work Unit No.	
15. Supplementary Notes M. V. V. Murthy: NRC-NASA Resident Research Associate. Scientist (on leave from) National Aeronautical Laboratory, Bangalore-560017, India.				11. Contract or Grant No.	
16. Abstract <p>An improved transverse shear deformation theory for laminated anisotropic plates under bending is presented. The theory eliminates the need for an arbitrarily chosen shear correction factor. For a general laminate with coupled bending and stretching, the constitutive equations connecting stress resultants with average displacements and rotations are derived. Simplified forms of these relations are also obtained for the special case of a symmetric laminate with uncoupled bending. The governing equation for this special case is obtained as a sixth-order equation for the normal displacement requiring prescription of the three physically natural boundary conditions along each edge. For the limiting case of isotropy, the present theory reduces to an improved version of Mindlin's theory. Numerical results are obtained from the present theory for an example of a laminated plate under cylindrical bending. Comparison with results from exact three-dimensional analysis shows that the present theory is more accurate than other theories of equivalent order.</p>				13. Type of Report and Period Covered Technical Paper	
17. Key Words (Suggested by Author(s)) Shear deformation Laminated plates Anisotropic plates Plate bending theory Higher order plate theory				14. Sponsoring Agency Code	
18. Distribution Statement Unclassified - Unlimited Subject Category 39					
19. Security Classif. (of this report) Unclassified	20. Security Classif. (of this page) Unclassified	21. No. of Pages 37	22. Price A03		