

Received May 31, 2019, accepted June 18, 2019, date of publication June 24, 2019, date of current version July 11, 2019.

Digital Object Identifier 10.1109/ACCESS.2019.2924805

An Inclusive Survey on Array Antenna Design for Millimeter-Wave Communications

SASWATI GHOSH¹, (Senior Member, IEEE), AND DEBARATI SEN, (Senior Member, IEEE)

G. S. Sanyal School of Telecommunications, IIT Kharagpur, Kharagpur 721302, India

Corresponding author: Saswati Ghosh (saswatikgp@gmail.com)

This work was supported by the Science and Engineering Research Board (SERB), Government of India, through the IMPRINT Project, Design and development of wide-band millimeter-wave phased array antenna with beam-forming module (File no. IMP/2018/001282/dated. 28.09.2018).

ABSTRACT The enormous growth of wireless data traffic in recent years has made the millimeter-wave (mm-wave) technology as a good fit for high-speed communication systems. Extensive works are continuing from the device to system, to the radio architecture, to the network to support the communication in mm-wave frequency ranges. To support this extensive high data rate, beam forming is found to be the key-enabling technology. Hence, an array antenna design is an extremely important issue. The beam-forming arrays are chosen to achieve the desired link capacity considering the high path loss and atmospheric loss at mm-wave frequencies and also to increase the coverage of the mm-wave communication system. There are diverse design challenges of the array due to the small size, use of large numbers of antennas in close vicinity, integration with radio-frequency (RF) front ends, hardware constraints, and so on. This paper focuses on the evolution and development of mm-wave array antenna and its implementation for wireless communication and numerous other related areas. The scope of the discussion is extended on the reported works in every sphere of mm-wave antenna array design, including the selection of antenna elements, array configurations, feed mechanism, integration with front-end circuitry to understand the effects on system performance, and the underlying reason of it. The new design aspects and research directions are unfolded as a result of this discussion.

INDEX TERMS Mm-wave communication, antenna array design, array configuration, feed mechanism, RF circuit.

I. INTRODUCTION

With the ever increasing demand of wireless data traffic, the spectrum shortage in the microwave frequency band has become more prominent. This necessitates exploring the millimeter wave (mm-wave) frequency range (30 – 300 GHz) for future 5G communications with high speed wireless connectivity for mobile, imaging, and multimedia applications [1]. Mm-wave has found emerging applications in broadband cellular communication, intra-vehicular and inter-vehicular communication, aerospace communication, medical imaging etc. The fundamental differences between the mm-wave communications and existing other communication systems operating in microwave frequency range (e.g. 2.4 GHz and 5 GHz band) should be kept in mind while designing mm-wave devices [2]. The mm-wave communications suffer from

sensitivity to blockage due to weak diffraction capability, huge propagation loss due to the high carrier frequency, high losses due to atmospheric oxygen and water vapor [1]. These characteristics of mm-wave may be positively utilized for efficient spectrum reuse and enhanced security in communication. However, the severe path loss at mm-wave frequency limits the communication distance, which is the key issue in mm-wave communications. This sets new challenges in all the layers - physical (PHY), medium access control (MAC), and routing layers which require to choose new signal processing, circuit, antenna and communication technologies [1]. The large scale antenna array with high gain is used to combat the severe propagation loss. The increased directivity of the array reduces the main lobe beam-width. This requires the use of beam-forming array antenna, which improves the coverage and provides continuous signal or user tracing. Rapid progress in the area of complementary metal-oxide-semiconductor (CMOS) radio frequency (RF)

The associate editor coordinating the review of this manuscript and approving it for publication was Xiu Yin Zhang.

integrated circuits motivates the use of mm-wave and sub-mm-wave bands for commercial use [3], [4]. As a result, several standards have recently been defined for indoor wireless personal area networks (WPAN) or wireless local area networks (WLAN) at 60 GHz band [5], [6]. The excessively high path loss at mm-wave ranges due to oxygen absorption prevents long distant communications. However, for short range WPANs the path loss provides extra spatial isolation and higher implicit security [3]. Also the higher level of equivalent isotropically radiated power (EIRP) allowed by the regulatory committees for mm-wave compared to other WLAN/WPAN standards facilitates the multi-gigabit-per-second wireless transmission over typical indoor distances (approx. 10 m) for mm-wave frequencies. Mm-wave technology is being considered as a promising alternative for 5G cellular networks [7]. Though the International Telecommunication Union announces the 3.4 – 3.6 GHz, 5 – 6 GHz, 24.25 – 27.5 GHz, 37 – 40.5 GHz, 60 GHz bands (57 – 64 GHz and 64 – 71 GHz), and 70/80 GHz bands (71 – 76 GHz, 81 – 86 GHz) for 5G communications, the limited spectrum resource available sub – 6 GHz encourages the use of mm-wave frequencies for the desired bandwidth requirement [8], [9]. Active research is continuing on the use of the 28 GHz, 38 GHz, 60 GHz and the E-band (71 – 76 GHz and 81 – 86 GHz) for mm-wave communications [2]. To compensate the high propagation loss, the use of highly directional antenna and steerable antenna beams become necessary. The antenna array technology helps in producing highly directive and steerable beams. Also, the small wavelength of the mm-wave region facilitates the array architecture to be embedded into portable devices. The use of multiple antenna helps to achieve multiplexing gain by transmission of parallel data streams simultaneously over multiple antennas, diversity gain which reduces bit error rate and antenna gain (improved signal-to-noise-plus-interference ratio of wireless systems) [10]. The antenna array configuration with appropriate beam-former increases the Rician K-factor gain and reduces the root-mean-squared (RMS) delay spread due to multipath dispersion at the receiver. Thus the design of suitable beam forming array antenna in the mm-wave frequencies has become essential for 5G communications. The phased array is used to focus and steer the transmitted or received electromagnetic energy along a certain direction [11]. To achieve the steering, a specific time delay is introduced between the elements of the array so that the contributions from all the elements are coherently summed at a particular angle to the array face. The concept of phased array is conceived in the early 1900s [12], [13]. Initially the array antenna is designed for a fixed beam-pointing and mechanical rotation is used for beam steering [14]. Gradually the technology of steering the beam by mechanically controlling the phase shift at each element evolved. The development of electronic steering in 1960s phased array becomes advantageous as it helps to avoid the repositioning of huge reflectors and feed assemblies for tracking purpose [13]. A survey on different beam steering techniques for mm-wave applications

is presented in [15]. The design of antenna array at mm-wave frequencies is a very complex job and includes several design challenges:

- The size of the antenna array should be reduced to integrate the whole array in portable high frequency devices. The small size of the array structure increases the fabrication error and complexity. Also to achieve the desired scanning performance and avoid the grating lobes, the inter-element spacing is kept small. The close proximity of these elements causes high mutual coupling which degrades the array performance. The mutual coupling is an important issue which needs special attention. Different mechanisms are chosen to reduce the mutual coupling.
- The losses in the feed lines of the array, phase shifter, become appreciable in mm-wave frequencies and need special care in the design. This high loss reduces the system sensitivity and efficiency.
- The antenna array is desired to be integrated with other circuitry e.g. front end detector and amplifier circuits for the implementation of low cost mm-wave systems. Different antenna integration technologies e.g. system-on-chip, system-in-package or standard laminate substrates are chosen according to the nature of application and gain requirement [16]. This requires the judicious selection of the antenna materials with known characteristics and low loss at mm-wave frequencies. Also the electromagnetic interference (EMI) between the antennas and other front end modules hamper the operation of both the antennas and circuits.

The huge applications of mm-wave in various scientific areas require a detailed understanding and knowledge on the design of mm-wave antennas, beam-forming array, and a complete study including all these concerns as a whole. The application areas of mm-wave communications are not only limited to cellular communication, but also include different areas e.g. radar communication, automotive radars, device to device communication, medical imaging, security and healthcare, internet of things (IoT) etc which involve wide range of frequency starting from 10 GHz to 300 GHz. The mm-wave frequency range with specific application areas are summarized in Table 1.

Few survey and tutorial papers are published on different aspects of mm-wave communications and its application areas [2], [4], [8], [15], [16], [17], [18]. The survey on the solutions and standards used in designing the architectures and protocols for mm-wave communications till 2015 with several application areas are presented in [2]. It also suggests open research challenges in the physical layer technology, network architecture, control mechanisms etc for 5G communications [2]. The advancements in the design of mm-wave circuit components e.g. power amplifiers, low noise amplifiers, analog-to-digital converters, on-chip and in-package antennas for 60 GHz transceiver design are discussed in [4]. Though the research activities on on-chip and in-package antennas till 2011 is presented in [4], the latest developments

TABLE 1. Mm-wave frequency range specific applications.

Frequency	Potential application
45 GHz	Wireless Local Area Network (WLAN) (802.11aj)
57 - 64 GHz	WiGig unlicensed band, 2.5 Gbps, 802.15, 802.11ad, Wireless HD
60 GHz	WPAN / WLAN (IEEE802.15.3c, 802.11ad/ay), Wireless backhaul [19]
71 - 76 GHz	Point-to-point licensed communications links, 1.25 Gbps to 10 Gbps (planned), Wireless backhaul application
77 GHz	Automotive radar
81 - 86 GHz	Point-to-point licensed communications links, 1.25 Gbps to 10 Gbps (planned), Wireless backhaul application
92 - 95 GHz	Point-to-point licensed communications links, 1.25 Gbps to 10 Gbps (planned), Wireless backhaul application
94 GHz	100 MHz band reserved for space-borne radios, Imaging radar, Airport ground control
110 - 500 GHz	Materials imaging
120 - 124 GHz 138 - 144 GHz	Local networking
122 GHz	Automotive radar
180 - 210 GHz	Atmospheric radar
180 - 300 GHz	Security and healthcare

including antenna arrays, feed mechanism, material properties etc. are not discussed. An interesting review of multi-beam antenna technologies, system architecture and beam-forming methods is presented in [8]. The passive and phased array multi-beam antenna system based on reflectors, lens etc., beam-forming circuits, design and implementation, applications and challenges in view of the development till 2017 are covered in [8]. The paper points out the problem of implementation of the multi-beam array with the transceiver chips in planar multi-layer printed circuit board (PCB) configuration with optimized cost, performance and complexity. However, a detailed discussion on the planar integrated phased array antenna is avoided in [8]. The various techniques used to achieve beam steering in mm-wave frequency range are analyzed in [15]. A very useful survey presenting the development and suitability of different beam forming methods for mm-wave communications including the challenges and characteristics of mm-wave frequencies is found in [16]. Different applications of mm-wave for massive MIMO and vehicular technology are surveyed in [17] and [18]. However, it is noticed that a detailed discussion on the antenna array design, methodology, feed mechanism, array design strategy to enable efficient beam-forming, steering and tracking is not well addressed yet. The selection of materials for antenna design specially for planar structure is also expected to play a crucial role in association with the array structure and dimension to optimize the array performance in mm-wave frequencies. Hence, there is a need for an inclusive survey on the array antenna design for various application areas that come under the ambit of mm-wave communication over the range of 10 - 100 GHz till today. In this survey paper, we present a comprehensive work covering all these areas simultaneously.

The scope of this paper includes brief description of different types of array antennas with special emphasis on application to mm-wave communications. The usage and suitability of micro-strip antenna for mm-wave beam-former design and the emerging technologies are described. Also a comparative study of the performance of the systems presented in recent works is included to identify the gaps and challenges of the work and the areas to improve the performance.

The rest of this paper is organized as follows. Section II presents different antenna array architectures and approaches. The working principle of phased array is briefly described in Section III. Section IV briefly describes the important array parameters. Section V addresses the key issues in mm-wave array antenna design including the element characteristics, substrate loss, effect of feeding techniques, mutual coupling between array elements etc. Even the effect of electromagnetic interference (EMI) with RF front ends and antennas is discussed in this section. The system design and implementation aspects, with emphasis on advancements in mm-wave antenna array design are discussed in Section VI. The development and application of mm-wave phased array design in different areas are briefly discussed in Section VII. In Section VIII, the discussion is summarized and the survey is concluded with a suggestion to future research directions.

II. ANTENNA ARRAY ARCHITECTURES AND APPROACHES

The huge development during 1950 – 60s made the antenna array specially phased array an inevitable technology for different applications e.g. radar, communications, remote sensing, navigation, automotive, biomedical imaging and in many other fields [20]–[22]. The continuous growth in the area of wireless services and applications has become helpful for the design of today's array antennas. The array antennas are broadly classified in several categories according to the various design parameters, e.g. geometrical configuration, electrical architecture, feeding mechanism etc. Each category is subdivided into several classes according to the design approach which is briefly presented in this section. Categorization of the different approaches is provided in Figure 1 for quick reference. The pros and cons of the different types of array configurations are summarized in Table II.

A. GEOMETRICAL CONFIGURATION

According to the geometrical configuration the antenna array is classified into linear and planar structures considering

**FIGURE 1. Broad categorization of antenna array approaches.**

TABLE 2. Different types of array architectures.

Antenna Architecture	Advantages	Disadvantages
Geometrical: <ul style="list-style-type: none"> • Linear [24] - [46] • Planar [25] - [27] 	Linear: <ul style="list-style-type: none"> • Simple array arrangement [23], [24], [46] Planar: <ul style="list-style-type: none"> • Beam steering in two planes • Azimuthal scan with minimum change in beam-width and side-lobe level using uniform circular array [27] • Appreciably reduced number of elements using triangular pattern [25] 	Linear <ul style="list-style-type: none"> • Ray deflection is performed only in a single plane Planar <ul style="list-style-type: none"> • Increased cost and complexity due to complicated array arrangement
Feed Mechanism: <ul style="list-style-type: none"> • Space Feed [36], [64] • Constrained Feed [37] - [47] 	Space Feed: <ul style="list-style-type: none"> • Simplest way to produce multiple simultaneous beams • Elimination of loss and parasitic radiation due to feed network • Wide instantaneous bandwidth time-delay type phase shifter • Phase shifter and feed characteristics need to be included to estimate polarization of array Constrained Feed: <ul style="list-style-type: none"> • Reduced insertion loss and radiation loss due to compact feed network [65] • Cumulative phase shift relaxes design constraints on tuning range of phase shifter • Array polarization can be determined primarily by element pattern 	Space Feed: <ul style="list-style-type: none"> • Requirement of large physical volume • Multiple reflection effect due to mismatches between two lens apertures Constrained Feed: <ul style="list-style-type: none"> • Beam squint with frequency due to progressive phase change between radiation elements in series type • Mismatches from antennas, phase shifters etc. add up in phase for path length=$n\lambda/2$ • Decreased antenna gain with increased side lobe level due to the additive insertion loss of serial phase shifters
Layout: <ul style="list-style-type: none"> • Irregular 	<ul style="list-style-type: none"> • Simple array design using reduced number of control devices • Beam pattern close to fully populated architecture using lesser number of elements [28] 	<ul style="list-style-type: none"> • Reduced configuration flexibility and operation bandwidth [32], [66] • Requirement of sub-array synthesis strategy to achieve good resultant power pattern [30], [31] • Expected array performance can not be estimated properly using optimization techniques [13], [33]
Beam-forming architecture: <ul style="list-style-type: none"> • Analog RF [51], [15] • Analog LO [55] • Analog BB [49] • Digital [57], [63] • Hybrid [16] 	Analog RF: <ul style="list-style-type: none"> • Reduced cost and power requirement due to the use of least number of circuit components [51] Analog LO: <ul style="list-style-type: none"> • Bandwidth and linearity requirement of phase shifter is not very stringent [55] Analog BB: <ul style="list-style-type: none"> • Realization of phase shifter at low frequencies with high resolution, low power and small foot-print Digital: <ul style="list-style-type: none"> • Suppressed grating lobes [57], [63] • Improved array performance without unwanted beam squint effects • Flexible power and time management Hybrid: <ul style="list-style-type: none"> • Improved performance compared to analog beam-forming while reducing the complexity of digital beam-forming [16] 	Analog RF: <ul style="list-style-type: none"> • Difficulty in implementation of phase shifter • Phase shifting network suffers from poor isolation • Larger insertion loss in power combining / distributing circuit [8] • Narrow bandwidth due to the frequency dependent characteristics of phase shifter [15] Analog IF and BB: <ul style="list-style-type: none"> • Increased noise sensitivity due to the use of distributed LO signal to local elements [49] Analog LO: <ul style="list-style-type: none"> • Increased cost, size and power consumption due to the use of more circuit blocks, specially additional mixers Digital: <ul style="list-style-type: none"> • Increased power requirement in phase shifting and adding operations • Increased circuit complexity, cost and processing time Hybrid: <ul style="list-style-type: none"> • Increased array complexity and system cost compared to passive array

the placement of array elements. In general, the identical radiators are arranged in linear, rectangular, triangular and circular lattice with periodic spacing between them to achieve the desired radiation pattern. The array beam-forming performance depends on the choice of array configuration, physical structure of each element, excitation of the elements.

1) LINEAR ARRAY

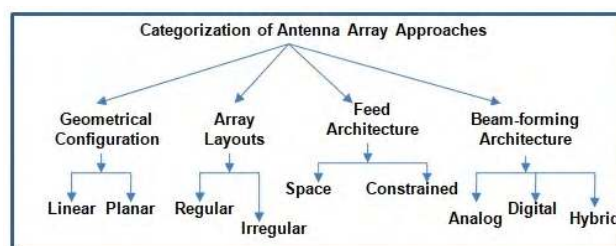
The beam forming and beam steering of the main antenna lobes on a single plane are obtained via a linear phase taper of the signal fed to the array elements (Figure 2(a)) [23]. The discrete array is considered as the limiting case of a continuous aperture illumination for the convenience of applying the array synthesis procedure to formulate radiation pattern [24]. The broadside linear array of isotropic elements produces

a very wide pattern in a plane perpendicular to the array axis and a narrow pattern in the plane of the array. For omni-directional and few simple elements, the directivity is integrated in closed form. However, for realistic elements, the radiation from the array and directivity is evaluated using potential functions considering magnetic and electric potentials which include the mutual coupling between array elements [24]. The detailed analysis in this area is out of the scope of this survey. The linear array antenna with constant magnitude and phase excitation produces optimum directivity for most arrays.

2) PLANAR ARRAY

The planar arrays are used to achieve beam steering in both the azimuth and elevation planes. The most common planar

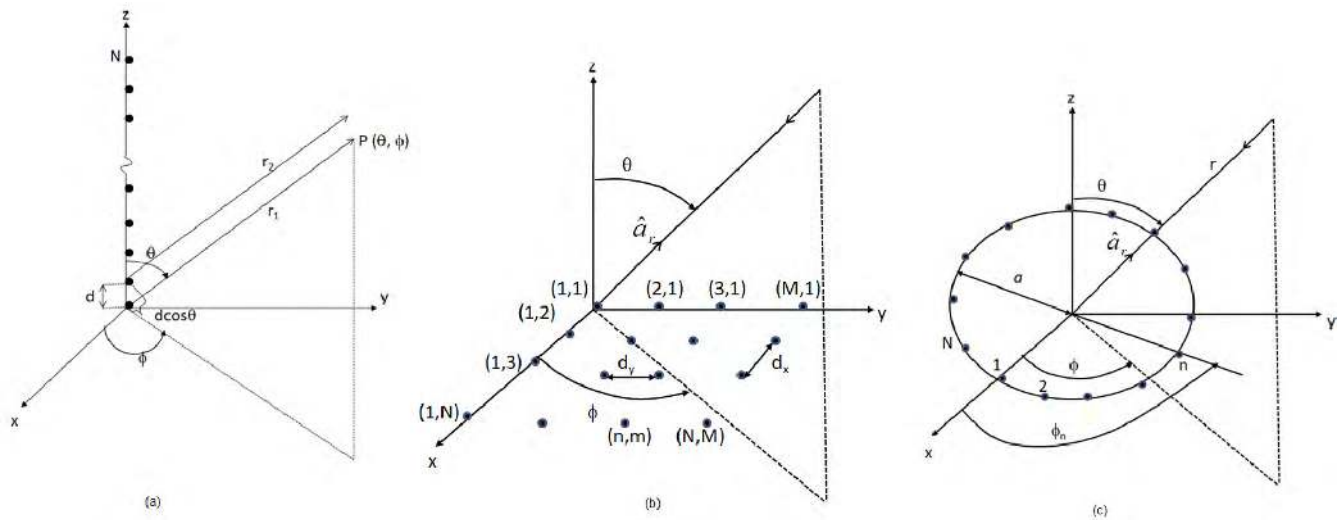

FIGURE 2. Different types of array antenna geometries: (a) linear; (b) rectangular; (c) circular.

array structures are the rectangular/square array with equal spacing between adjacent elements in each column and row as shown in Figure 2(b). For a large array, the application of huge number of antenna elements, associated phase shifters, and other components increase the overall cost and complexity of the system. It is found that by arranging the elements in triangular pattern, the number of required elements can be reduced appreciably (approx. 13.4 % for uniformly spaced elements) [25]. The rectangular array is used for rectangular scan coverage whereas the triangular lattice produces conical scan coverage. The circular arrays (Figure 2(c)) with the elements arranged in concentric circles are preferred for some applications due to lower first side lobe level [26]. The uniform circular array also enables the array to scan azimuthally with minimum change in beam-width and side-lobe level [27].

B. ARRAY LAYOUTS

According to the layouts the phased array is divided into regular and irregular array structures. In conventional array structures, the antennas are arranged on a regular lattice or grid with constant inter-element distance. This type of array structure is referred as regular array structures. The discussion till this subsection includes only the regular array structures.

For certain modern applications, multiple functionalities of phased array are required with larger bandwidth, higher re-configurability, smaller size etc. [28]. Also the advancement in the design of high power amplifiers and analog-to-digital converters encourages for the design of high power and digital beam-forming array, which further increases the cost, complexity and weight of the array. The irregular arrays offer a viable solution with desired cost/performance trade off in this situation. The whole array is divided into a number of uniformly excited sub-arrays with shapes and weighting

coefficients calculated fulfilling the design constraints [29]. The irregular array structures are broadly classified in clustered, thinned (Figure 3(a)) and sparse (Figure 3(b)) according to their electrical performance [28]. These types of irregular arrays are used for different applications e.g. wireless power transmission [28], [30], [31], satellite communication radar, remote sensing, biomedical imaging [32], [33], multiple-input-multiple-output (MIMO) applications, radar imaging [34], [35] etc.

C. FEED ARCHITECTURE

The selection of feed network of antenna array for a particular application depends on several criteria e.g. number of simultaneous beams, peak and average side lobe level, power, tunable and instantaneous bandwidth etc [36]. The feed network is broadly classified in space, constrained and hybrid feeds.

• Space feed

In space feed, the array elements are illuminated by the radiation of a feed antenna placed at the focal distance away from the aperture of the pick-up array [36] (Figure 4(a)).

• Constrained feed

The constrained feed is categorized into series (Figure 4(b)) and parallel/corporate (Figure 4(c)) feed network.

In a series feed, the radiating elements are fed serially while in parallel feed, they are fed in parallel. In a typical series fed array, the input signal is fed from one end while the other end is terminated in matched load [36]. This type of antenna has found interesting applications in mm-wave beam switching arrays [37]–[40]. Interesting micro-strip comb line array configuration is designed in [37], [38] with rectangular radiating elements connected directly to the straight feed-line. The transmission line connecting the elements incorporates the progressive phase difference between the elements. This results in travelling wave operation of

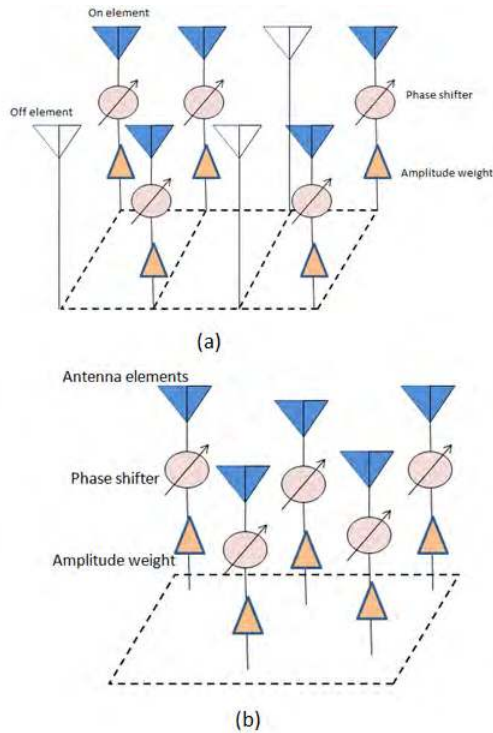

FIGURE 3. Irregular phased array architecture: (a) thinned; (b) sparse.

the array. Also, the reflection cancelling slit structure is inserted on the feed-line around each radiating element to reduce the reflection [40]. Later to improve the return loss characteristics of the array, the matching-circuit integrated to the radiating elements is used [41]. Several micro-strip comb-line arrays with different beam directions are used for the design of mm-wave beam switching applications [42]. However, the series fed phased array is limited for narrow band applications. With the increase in the transmission line length from the input to the following radiating elements, a progressive phase change occurs between the elements with frequency variations. This results beam squinting effect. The amount of beam squint is expressed as $beam\ squint = \frac{\Delta f}{f} \frac{1}{\cos\theta_0}$. Here Δf is the change in frequency and θ_0 is the nominal scan angle [36].

In parallel feed, the transmit power is divided in a corporate tree fashion to all the radiating elements. The length of every feeding line is equal which makes in-phase power division. In this case, the frequency bandwidth for broadside is ideally infinite, only limitations are due to the components e.g. coupler, phase shifters, radiators etc. The beam scanning away from broadside direction shows variation with frequency. The amount of beam squint in this case is given as $beam\ squint = \frac{\Delta f}{f} \tan\theta_0$ [37]. At each level of the corporate feed network, the mismatches from the radiating elements are well isolated from each other. Also multiple simultaneous beams can be formed using Butler matrix or Blass matrix feed [43], [44]. The micro-strip arrays with parallel feed network are used for mm-wave applications [45], [46].

In some applications, the combination of linear and corporate feeding technique is simultaneously applied for designing high gain antennas [47]. The linear micro-strip patch array fed by corporate feeding mechanism is studied for mm-wave ultra wideband applications e.g. short range radar for vehicles in 79 - 80 GHz Frequency band [47].

A combination of space feed and constrained feed is preferred for some applications due to their high power handling capacity, low cost, low loss characteristics [48].

D. BEAM-FORMING ARCHITECTURE

The beam-forming is performed by aligning the phases of the incoming signal from different parts of an array to form a beam in a specific direction. According to the architecture the beam-forming array is broadly classified in the categories: analog, digital and hybrid beam-forming array [14], [15], [26]. Different beam-forming architectures are shown in Figures 5–7. The digital beam-forming is performed in base-band (BB) domain while the hybrid architecture divides the beam-forming process in analog and digital domain.

1) ANALOG BEAM-FORMING ARRAY

The major RF front-end components of a beam-forming array are analog base-band, frequency generation, modulation and frequency conversion, power amplification and phase shifter. The analog baseband converts the coded base-band in-phase and quadrature (I/Q) digital bits to continuous time analog signals using digital to analog converters (DACs). The analog signals are filtered to reject the unwanted high frequency spectral contents. The filtered I/Q signals are used to modulate a high frequency carrier signal known as the local oscillator (LO) signal. The LO signal is usually generated by phase locked loop (PLL) with highly accurate reference frequency. In some array configurations the modulation is applied at the intermediate frequency (IF) and modulated signal is up-converted by a mixer. This architecture is advantageous due to its low power consumption, better phase noise performance and linear and power efficient modulation [49]. However, the mixer produces undesired spectral contents, which reduces the desired signal power and also potentially interferes with other communication links at that frequency band. Another approach is to use the modulation at the final RF carrier frequency. The signal is then amplified using power amplifier (PA) to achieve required power level. The power amplifier must be isolated from the voltage controlled oscillator (VCO) by using a good lay-out to minimize the pulling effect. The phase shifter is used to achieve the beam-forming characteristics.

The hardware architecture of the beam-forming array specially at mm-wave frequencies is quite complicated due to different hardware imperfections e.g. phase noise, power amplifier non-linearities, I/Q imbalance etc., which requires thorough analysis and design along-with potential solutions [50]. A detailed discussion on this area is out of the scope of this paper and avoided here concentrating only on the beam-forming array. According to the position of the phase

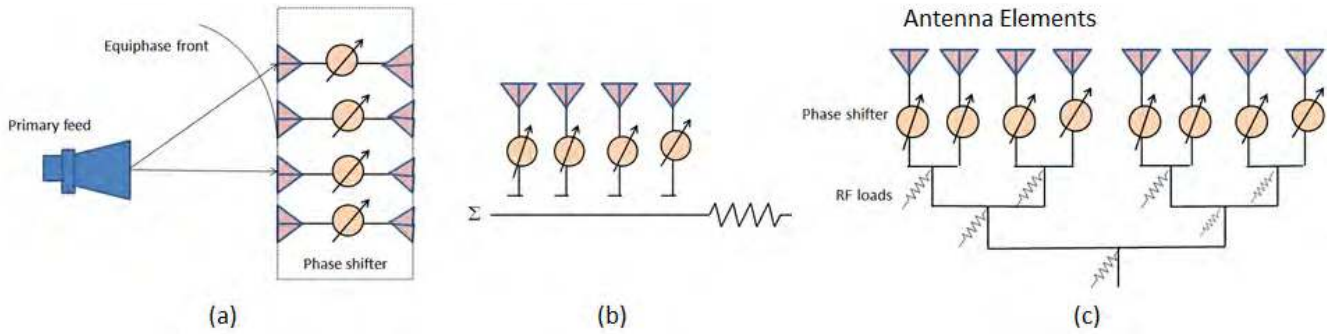

FIGURE 4. Different types of array feeding techniques: (a) space feed; (b) constrained series feed; (c) constrained parallel feed.

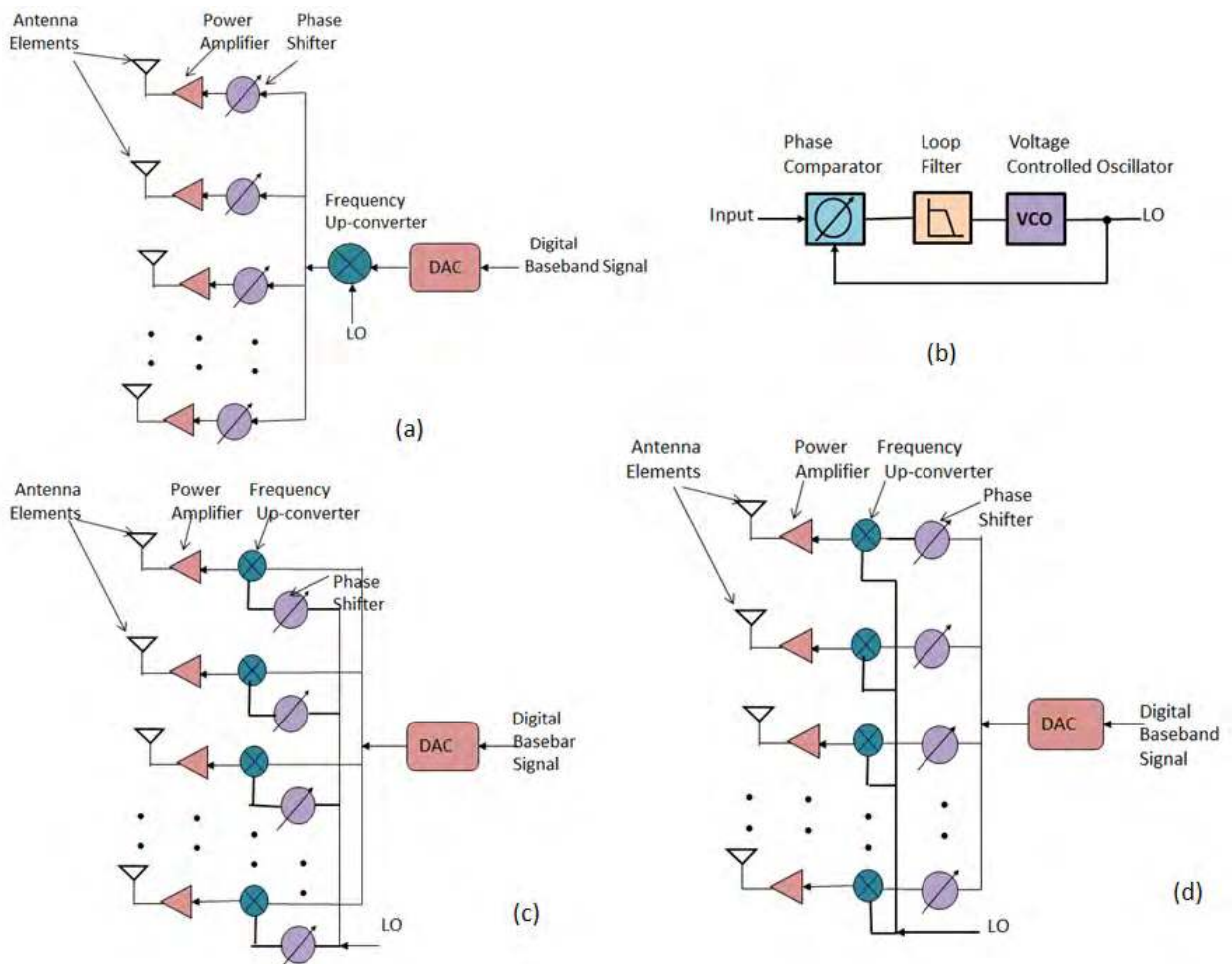

FIGURE 5. Analog beam-forming antenna array: (a) RF beam-forming; (b) generation of LO signal; (c) LO beam-forming; (d) base-band beam-forming.

shifter, the analog beam-forming array is broadly classified in analog RF, analog IF, analog base-band (BB) and analog LO beam-forming [16].

- Analog RF beam-forming

In RF beam-forming the relative phases of different antenna elements are adjusted in the RF signal domain. This architecture requires least number of circuit components which appreciably reduces the cost and power requirement [51]. However, phase shifter at high frequencies

specially mm-wave range is quite difficult to implement. The phase shifter becomes lossy at high frequencies due to the use of variable passive components, which requires another amplifier to compensate the gain variation. Also, for the applications requiring large bandwidth, the use of phase shifter poses a challenge due to its frequency dependent characteristics [15]. For wide-band applications, the true-time delay circuits can be used [8].

- Analog IF, BB beam-forming

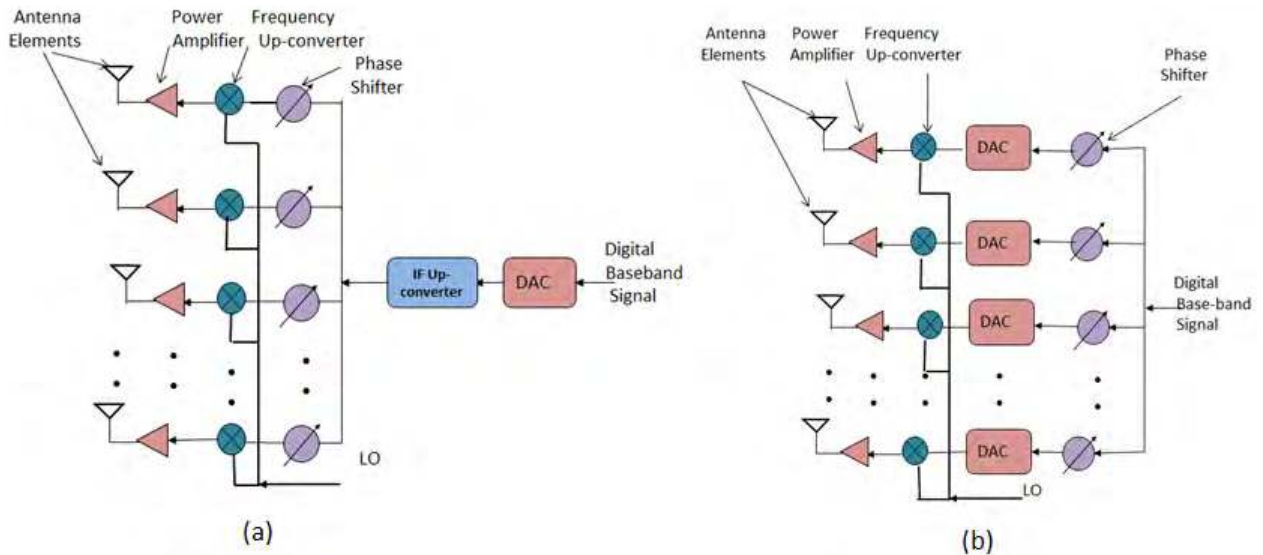

FIGURE 6. (a) Analog IF beam-forming; (b) digital beam-forming antenna array.

The relative phases of different antenna elements are adjusted in the analog IF [52] or base-band domain [53]. The phase shifter at low frequencies can be realized with high resolution, low insertion loss, low power and small foot-print. However, due to the use distributed LO signal to local elements, this architecture is more sensitive to noise. This requires special care to isolate the LO distribution path from noisy circuitry [49]. Also these two methodologies are applicable for narrow-band operation since it requires longer delay line even in IF for implementing certain time delay using analog approach [8].

• Analog LO beam-forming

In this architecture the relative phases of different antenna elements are adjusted in the LO signal domain [54]. Since the phase shifter is not implemented in the main signal path, the bandwidth and linearity requirement of the phase shifter is not so stringent as RF phase shifting architecture [55]. However, the requirement of more circuit blocks, specially additional mixers increases the cost, size and power consumption.

2) DIGITAL BEAM-FORMING ARRAY

In a digital array the radio frequency (RF) signal is converted to digital signal at the sub-array or element level and the digital signal processor is used for beamforming [14]. It has become popular with the rapid commercial evolution of digital processor technology. The sub-array digital beam-former provides multiple simultaneous beams over a limited scan sector [56]. The low side-lobes of the overlapped sub-array pattern suppress the grating lobes [57]–[62]. The recent developments of silicon-based RF integrated circuit (IC) design and fabrication allows the use of low cost element level digital transceiver with reduced cost, size and power consumption [63]. Thus the element level

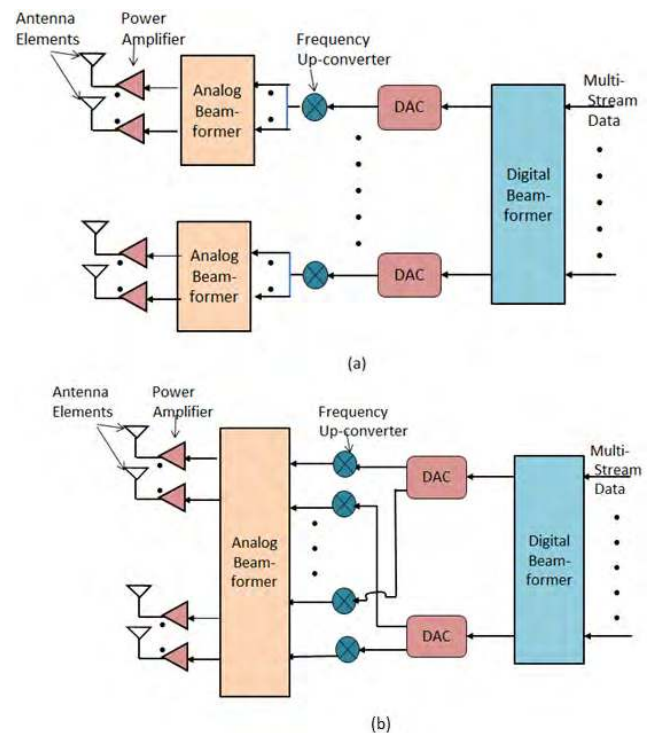

FIGURE 7. Hybrid beam-forming array antenna: (a) sub-array; (b) full-array.

digital beamforming has become more popular in recent years. Each element of the array uses a separate receiver/exciter (Figure 6(b)).

The digital phase shifting allows arbitrary time delays at each element which is useful to avoid unwanted beam squint effects in large arrays operating over wide bandwidth. Also, it significantly improves the array performance by producing improved adaptive pattern nulling, multiple

simultaneous beams over full scan volume. It has several additional advantages compared to analog beam-former e.g. antenna self-calibration, ultra-low side-lobes, array element pattern correction, and flexible power and time management. However, for mm-wave applications, this architecture also has several disadvantages. The phase shifting and adding operations become potentially power hungry due to the higher IF bandwidth of mm-wave transceiver. Also the implementation of RF/LO/IF paths multiple times increase the overall cost of the system.

3) HYBRID BEAM-FORMING ARRAY

The hybrid of analog and digital beam-forming array is recently finding growing interest. In this type of array, the complexity of digital beam-forming is reduced while improving the performance of analogue beam-forming. The hybrid beam-forming attaches the digital beam-forming architecture to the end of the analog beamformer. The analog beamforming section controls the phase of the signal at each element while the digital beamforming section applies baseband signal processing to enhance the performance of the multiple data channels [16].

Different types of architectures have several advantages and disadvantages which require proper selection for particular application considering the frequency, area, power, interference, robustness etc [49].

III. WORKING PRINCIPLE OF PHASED ARRAY

In a phased array, the major radiation from the array is oriented in the desired direction by controlling the phase excitation between the elements. This requires the proper choice of number, geometrical arrangement, relative amplitudes and phases of the array elements [67]. The working principle is described for the simplest form of antenna array i.e. linear array (Figure 2(a)). The array of identical elements are excited by equal magnitude and each with a progressive phase difference. The total field is obtained by using the pattern multiplication rule i.e. multiplying the field of an individual element by the array factor considering point source elements. For an array of equally spaced identical elements excited with equal amplitudes and uniform progressive phase α , the array factor $F_a(\theta, \phi)$ is proportional to the radiated field at a point in space as

$$F_a(\theta, \phi) = \sum_{n=0}^{N-1} \frac{I_n}{I_c} e^{jn(kd\cos\theta + \alpha)} \quad (1)$$

Here $k = \frac{2\pi}{\lambda}$, λ is the wavelength, d is the inter element spacing, I_c and I_n are the magnitude of the current on the center and n -th element respectively [26]. The major radiation from the array is oriented from broadside to the desired direction θ_0 by controlling the phase excitation between the elements such that $kd\cos\theta_0 = -\alpha$ i.e. $\theta_0 = \arccos[\frac{-\alpha}{2\pi} \frac{\lambda}{d}]$. The design is optimized by selecting both the maxima of single element and array factor towards the desired angular direction. The requirements for the array factor are achieved

by appropriately choosing the inter-element spacing (d) and phase excitation between the elements. For a requirement of maximum radiation of the array to be oriented at an angle θ_0 ($0^\circ \leq \theta_0 \leq 180^\circ$), the phase excitation α between the elements is achieved from equation (1) as $kd\cos\theta_0 = \alpha$. The total beam-width of the array is achieved as [67]

$$\Theta_h = \cos^{-1}[\cos\theta_0 - 0.44 \frac{\lambda}{L+d}] - \cos^{-1}[\cos\theta_0 + 0.44 \frac{\lambda}{L+d}] \quad (2)$$

Here L is the length of the array. This equation is valid for the half-power beam-width of a broadside and uniform scanning array. When the beam reaches towards the end-fire direction, a position is reached from where the half power point is achieved only on one side of the beam. This gives the scan limit of the antenna.

The inter-element spacing is another important factor for phased array design. If the inter-element spacing is sufficiently large compared to the wavelength, the in-phase addition of radiated field may occur in more than one directions [26], [67]. This causes multiple maxima of almost equal magnitude in the visible region. The principal maxima is referred to as the main lobe and the remaining lobes are called grating lobes [67]. The presence of grating lobe is to be avoided in phased array antenna. The grating lobe will appear at an angle θ' if equation (1) shows any maxima at that angle. This will occur when $kd\cos\theta' + \alpha = 2\pi$ i.e. $\cos\theta' = \cos\theta_0 \frac{\lambda}{d}$. Thus, to avoid the grating lobe, the inter element spacing is to be chosen such that it satisfies the condition $\frac{d}{\lambda} < \frac{1}{1+|\cos\theta_0|}$ [26]. The angular radiation patterns of a y-directed uniform broadside array of microstrip patch antenna with $N = 10$ and inter-element spacing $d = \frac{\lambda}{2}$ and $d = \lambda$ respectively achieved using electromagnetic simulation software CST Microwave Studio are shown in Figures 8–9 as example. It is noticed that to avoid the grating lobe at $\theta_0 = 90^\circ$ the $\frac{d}{\lambda} < 1$.

IV. ANTENNA ARRAY PARAMETER

The important array parameters are presented in brief in this section to maintain the flow of the work and for better understanding.

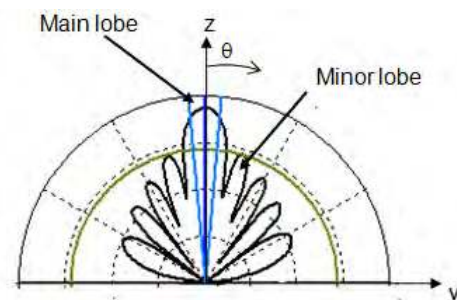

FIGURE 8. Array factor pattern of y-directed ten element uniform array with inter-element spacing = $\frac{\lambda}{2}$ and $\alpha = 0^\circ$.

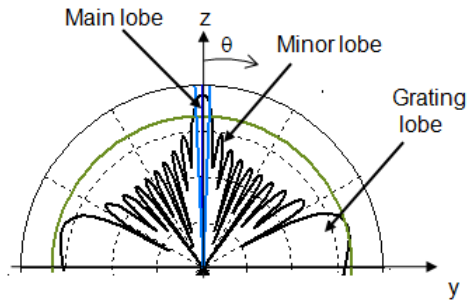

FIGURE 9. Array factor pattern of y -directed ten element uniform array with inter-element spacing = λ and $\alpha = 0^\circ$.

- Efficiency:** The radiation efficiency e_{rad} of an antenna/array is defined as the ratio of the power delivered to the antenna to the power radiated by the antenna [24]. Thus the efficiency mainly depends on the amount of power loss due to conductor and dielectric material. For array antenna, the feed-line loss also needs to be added. The total efficiency e_{tot} includes the impedance mismatch loss of the antenna. The efficiency can be improved by reducing the surface wave loss by partial removal of substrate material [68], reducing mutual coupling between array elements [69].
- Gain:** According to the IEEE standard definition the gain $G(\theta, \phi)$ of an antenna/array is defined by the directivity for each polarization reduced by the efficiency factor e_{rad} [24]. The array antenna is used to direct the radiated power at the desired angular sector by properly choosing the number, geometrical arrangement, relative amplitudes and phases of the array elements [67]. The directivity of the antenna/array in a certain direction θ_0 is given by the ratio of maximum power radiated per unit solid angle divided by the average power radiated (total power radiated divided by 4π) or $D = \frac{|E(\theta_0)|^2}{|E(\theta)|^2_{average}}$ [70], [71]. Here $|E(\theta)|^2_{average}$ is equal to the average of $|E(\theta)|^2$ over 4π steradian. $E(\theta)$ is the total radiated electric field which includes the element pattern and the array pattern. For non-uniformly weighted linear arrays, the directivity is given by $D = \frac{2d}{\lambda} D_0$. Here D_0 is given by the relation $D_0 = \frac{|\sum_{n=0}^{N-1} I_n|^2}{\sum_{n=0}^{N-1} I_n^2}$ [26]. In real applications, the elements of the array are non-isotropic elements and it is required to know the current distribution in each of the radiating element. Also the input impedance of an array changes with the scan angle due to the mutual coupling between the elements [24]. For array antennas, the realized gain is often used which is evaluated in terms of the total efficiency including the reflection and dissipation loss along with the array directivity. The array gain can be enhanced by introducing superstrate layer [72], controlling the front to back ratio by optimizing the reflector ground plane edge width [73] etc.
- Array Polarization:** The polarization of an antenna/array is described as the locus traced by the

extremity of the time-varying electric field vector at a given observation point. According to the shape of the trace, it is classified in linear, elliptical and circular polarization. The polarization of an array depends on the polarization of individual element of the array, mutual coupling which depends on array size, architecture, feeding technique, phase shifter components used etc [74].

The mutual coupling causes degradation of cross polarization isolation with increased scan angle. The polarization purity can be maintained by reducing the mutual coupling using meta-materials [75], [76], The polarization compensation techniques are sometimes used to maintain polarization purity, which add up to the cost and complexity of the system [74].

V. MILLIMETER WAVE ANTENNA ARRAY

The design of phased array in the mm-wave frequency range puts some additional design challenges compared to the more general low frequency phased arrays. The design challenges and their solutions are presented in this section.

A. ELEMENT CHARACTERISTICS

The antenna element is a major component in the design of phased array antenna. The antenna element is chosen according to the array requirements e.g. operating bandwidth, gain, polarization, side lobe level, maintainability, reliability etc. However, the performance of the overall system depends on the other components e.g. phase shifters, feed networks and a trade off in selecting the components can be made to achieve the optimum performance with cost minimization [36]. For mm-wave communication system, extra importance is given on the antenna gain (to compensate the high attenuation and path loss), size, and compatibility with other radio frequency modules [70]. The commonly used high gain antennas e.g. reflector, lens, horn antennas are suitable for mm-wave communications [77]. A circularly polarized reflectarray with two substrate layers using interlaced ground plane with cross-slots is designed for Ka-band satellite and radar applications [78]. The broad-band meta-material enabled horn antenna with improved cross-polarization isolation and aperture efficiency is used for dual-polarized satellite antenna in Ku-band [79]. However, in the present scenario, these antennas are not preferred for commercial mm-wave applications due to their large weight, high cost and bulky structure and inability to be integrated with solid state devices [80]. Different mm-wave antennas are broadly classified in several groups e.g. leaky-wave antennas based on open mm-waveguides, integrated antennas with the active and passive circuits combined with the radiating elements in monolithic form and micro-strip and printed circuit antennas etc [81].

In mm-waveguides e.g. dielectric guide, energy leakage occurs if the uniformity of the guide is perturbed. This leakage effect is used to introduce perturbations in the guides to achieve a controlled radiation in mm-wave frequency scanning array [82].

The integrated antennas are referred to the radiating structures which are integrated with other devices e.g. solid-state oscillators, detectors, phase shifters, filters etc. on the same substrate in monolithic form [81]. These antennas are preferred for mm-wave power combining, beam steering and retro-directive arrays due to the desirable features e.g. compactness, light weight, minimum power consumption, low profile, multiple functionality etc [83]. Efforts are going on the design and development of efficient integrated antennas and the interesting recent works are reviewed in Section VI. The integrated antennas are broadly classified in several groups e.g. receive antenna with integrated detectors, transmit antenna with integrated oscillators and others according to their design principles [84].

The radiation efficiency of the on-chip antennas is poor due to the low resistivity and high permittivity of silicon substrate used in IC. Also the inclusion of external antenna may cause serious mismatch at high frequencies due to the fabrication errors. In this situation, the bond wire antennas are used to achieve better efficiency and also is fed directly by the IC port to avoid coupling loss [85]–[87].

The micro-strip antennas are extensively used in UHF and microwave frequency bands [84], [88], however for mm-wave applications not only the size of the antenna changes, the substrate properties and thickness become additional parameters of concern. The substrate thickness is quite high in mm-wave operations compared to microwave frequencies. This affects the bandwidth and input impedance of the antenna. The feasibility study of the application of micro-strip antenna for mm-wave frequencies is performed in [89] which presents a 4×4 micro-strip array with high efficiency at 60 GHz frequency. The micro-strip patch and printed dipole antenna are the most widely used micro-strip antenna structures [90]. The advancement in the design of mm-wave micro-strip antennas is presented in [91].

B. MATERIAL PROPERTIES

The performance of micro-strip and integrated antennas depend on the selection of appropriate substrate materials. The commonly used substrate materials are characterized at lower frequency ranges upto 10 GHz. The substrate material properties of teflon and fused silica are studied for mm-wave applications [94]. Teflon is used for wave-guide slot arrays and the fused silica is chosen for integrated antennas [95]. The micro-strip antennas have several disadvantages e.g. low element gain, narrow bandwidth and limited power [96]. The gain can be improved by using arrays of elements. The power is limited by the thermal capacity of the substrate material. The other characteristics e.g. radiation pattern, bandwidth, input impedance, mutual impedance, efficiency etc. highly depend on the conductor properties, substrate thickness and relative permittivity values.

• Resonance Lengths:

The lengths of the printed antennas e.g. micro-strip patch depends on the thickness and permittivity of the substrate.

Also only a part of the medium surrounding the antenna element is filled with dielectric material. So the simple formulation for resonance length in homogeneous medium is not applicable for this case. A very good comparative study is performed by Pozar on simple micro-strip structures and commonly used substrate materials e.g. poly-tetra-flouro-ethylene (PTFE), quartz, gallium arsenide [88]. The plot of resonance length of micro-strip patch versus substrate thickness for PTFE material presented in [88] shows that the patch antenna stops resonating for substrate thickness $> 0.11\lambda_0$ (λ_0 is the resonance wavelength) for both probe-fed and micro-strip line fed structures. Thus thick substrates are not suitable specially for mm-wave frequencies unless the inductive trend of the input impedance is compensated using capacitive-gap coupling feed line [88]. Also the bandwidth of the antenna depends on the substrate width and for micro-strip patch, the bandwidth increases rapidly with increasing substrate thickness in the range $< 0.11\lambda_0$ [88].

• Loss due to Surface Waves

The dielectric substrate behaves as a very efficient surface waveguide with lowest order surface wave (TM_0) mode having zero cut off frequency $f_c = \frac{nc}{4h\sqrt{\epsilon_r-1}}$ [94]. Here c is the speed of light and $n = 0, 1, 2, 3, \dots$ determines the surface modes TM_0, TE_1, TM_2, TE_3 etc. Thus the lowest order surface mode is excited to some extent on very thin substrates [90]. For thicker substrates, more surface wave modes are excited and coupling to the lower order modes become stronger. The surface wave does not contribute to the main beam radiation and can be considered as loss mechanism. The radiation efficiency is expressed by $e_{rad} = \frac{P_{rad}}{P_{rad}+P_{sw}}$. Here P_{rad} defines the power radiated by space wave while P_{sw} determines the power coupled into surface waves. The diffraction of surface wave from the edge of finite sized substrate causes undesirable effects on side lobe level, polarization, main beam shape etc [90]. The surface wave may be coupled to or diffracted by the feed lines and other components on the substrate.

• Dielectric Loss

The power loss due to dielectric heating depends on the loss tangent and complex permittivity of the particular dielectric material. The plot of efficiency versus thickness of dielectric materials with different loss tangent for micro-strip patch and dipole shows that efficiency increases rapidly with substrate thickness [88]. This is expected as the fields are more concentrated for thin substrates and narrow antenna elements for a given power level. This causes more power loss as dielectric heating for thinner substrate and narrower elements [97].

• Conductor Loss

The electromagnetic loss in the conducting layer of the transmission line becomes prominent at high frequencies and needs to be estimated properly [98]. The conductor loss depends on the frequency of operation, conductivity and surface roughness of the metal used, thickness, width, boundary layer between the conductor and substrate material etc [99]. For ideal conductors, the conductor loss at high

TABLE 3. Different types of Mm-wave antennas.

Antenna Type	Advantages	Disadvantages
Conventional type: • Reflector, horn, lens antennas [78], [79] • Spiral [82] • Biconical, wire antennas [92]	• Suitable for rapid mechanical scanning due to the small size and high gain [81] • Constant directive gain, beam-width and circular polarization over wide impedance band-width • Broad-band, omnidirectional radiation pattern	• Heavy weight, high cost and bulky structure and not to be integrated with modern solid state devices [80]
Surface-wave and leaky-wave antennas [82] • Tapered dielectric rod • Dielectric resonator antenna • Corrugated dielectric slab antenna [93]	• Frequency scanning can be achieved by introducing suitable perturbations in the uniformity of the guide structure [82] • Low fabrication cost • No requirement of phase shifter appreciably reduces cost and energy consumption	• Scanning angle varies with frequency which is disadvantageous for point-to-point communication applications
Integrated antennas [83], [84]	• Compact, light weight, minimum power consumption, low profile, multiple functionality [83], [84]	• High radiation loss due to substrate absorption and conductive currents [4]
Bond wire antenna [85], [86], [87]	• Highly efficient, wideband, less coupling loss, reduced space	• Limited bandwidth is achieved for very thin bond-wire compared to its length
Microstrip and printed antennas [89], [90], [91]	• Compact, low cost, light weight, easily integrable with other front end components [89], [90], [91]	• High substrate loss • Large substrate thickness affects the bandwidth and input impedance of the antenna [4]

frequencies can be accurately calculated using electromagnetic simulators. Also for non-ideal conductors with greater thickness compared to the penetration depth, accurate results can be obtained from the surface impedance values [98]. The conductors with high melting temperature, low conductor loss, low resistivity, good line resolution and solderability are preferred for high frequency circuit design [99]. The mostly used conductors with these properties are aluminum, copper, gold, silver, and palladium-silver alloys [99].

C. FEED STRUCTURES

The common methods of exciting micro-strip antennas are direct feeding using co-axial probe or micro-strip line and indirect feeding without metallic contact between the feed line and antenna structure using electromagnetic coupling, aperture coupling or coplanar waveguide feed [100]. For coaxial feed arrangement, the increased probe length produces inductive impedance while choosing thicker substrate. Also, the probe feed is difficult to fabricate on monolithic substrates. For micro-strip line feeding, the width of the micro-strip feed line increases for increased substrate thickness, which further increases the undesired feed radiation. For micro-strip line feeding, the width of the feed line is independent of frequency and depends on the substrate thickness and permeability. However, the size of the resonant patch antenna decreases with increase in frequency. Thus at high frequencies, the feed line width may be comparable to the patch width which obstructs the radiation from the patch [90].

The feed line for electromagnetic coupling is placed between the micro-strip antenna and the ground plane separated by two dielectric media [94], [101]. Thus the spurious radiation from feed line can be eliminated here. Also the increase in overall substrate thickness increases the bandwidth. The performance of the antenna and also the feed line can be optimized by choosing two different dielectric media. The aperture-coupled feed configuration is also preferred for similar advantages.

The method of coplanar waveguide feeding has a disadvantage of higher radiation from longer slot, which leads to poor front-to-back ratio. The front-to-back ratio is improved by reducing the slot dimension and modifying its shape in the form of a loop.

D. ARRAY PERFORMANCE

The mutual coupling between array elements, radiation from feed network degrades the performance of an array. The increased substrate thickness excites more number of surface wave modes. The mutual coupling between array elements involves transfer of power from one element to another via space waves (direct radiation) and also by surface waves. The more number of surface wave modes for thicker substrate causes increased mutual coupling at mm-wave frequencies which degrades the array side-lobe levels, main beam shape and may cause scan blindness [102], [103]. Different techniques are employed to reduce the mutual coupling between array elements e.g. changing the feed position and feed structure [104], replacing the ordinary rectangular antenna by modified structure [75] etc, cutting slot inside ground plane known as defected ground plane of different shapes e.g. circles [105], rectangles [106], use of meta-material [76] etc. At higher frequencies, the ohmic and dielectric losses and parasitic radiation in the feed network degrades the efficiency of the antenna. The feed lines laid on the same plane as the antennas will also radiate and interfere with the main antenna radiation [107]. Hence the feed lines and antennas are preferably etched on different layers. The corporate feed configuration is preferred for mm-wave frequencies as it allows flexible choice of element spacing, broader bandwidth and integration with other devices such as amplifiers and phase shifters. However, this type of array requires more space for feed network. Also the feed line lengths become quite long for large array. This causes insertion loss specially at mm-wave frequencies and lowers the array gain.

E. ELECTROMAGNETIC INTERFERENCE

The partly or fully on-chip antennas are preferred for implementation of fully integrated radio systems in highly compact modules. The electromagnetic interference (EMI) is a major concern for the on-chip antennas and antenna-in-package (AiP) modules since it causes mutual coupling and affects the proper operation of both the antennas and circuits [108]. So, it is important to understand the coupling mechanism, effects of grounding etc. and use of shielding, filtering, decoupling etc. to reduce EMI related problems. The substrate and power line coupling are the main coupling mechanisms present in these modules. The layout of the antenna is kept away from the power lines, inductors and capacitors since the coupling may detune the antenna and its radiation pattern. Also the antenna coupling to sensitive circuit components e.g. low noise amplifier may degrade their performance. The widespread power lines on the chip behaves as an efficient antenna and couple with actual antenna. The filtering and decoupling techniques need to be applied to avoid the interference. The use of differential antennas, air cavity, guard rings, fences of vias are some of the techniques to reduce EMI for AiP solutions [108]. Thus while designing the actual transmit/receive module using phased array antenna at mm-wave frequency, the effects of EMI need to be considered.

VI. STATE OF THE ART TECHNOLOGIES

The evolution in the area of array antennas in the mm-wave frequency developed till date for different applications are presented in this section. Instead of looking into the 5G related applications only, we rather broadly discuss state of the art technologies in the array antenna design in the frequency range of 10 – 100 GHz. Though there may be sufficient number of mm-wave antennas with good performance, this paper mainly concentrates on the antennas/arrays with small size, easy to be integrated structures that can be used not only for cellular communications, but for advanced application areas e.g. radar communication, automotive radars, device to device communication, medical imaging, security and healthcare, internet of things (IoT) etc involving wide range of frequency starting from 10 GHz to 100 GHz. The consolidated list of reported works in the area of mm-wave antennas/arrays according to the frequency ranges is presented in Table 4. An exhaustive analysis of the reported works is performed highlighting the strengths and drawbacks of various antenna array structures, which helps in figuring out the appropriate array configuration for different applications.

A. X-BAND (10 – 12 GHz) AND KU-BAND (12 – 18 GHz)

The discussion starts with the antennas designed for different applications in the frequency range of 10 – 18 GHz. Different types of antennas have already been designed in this frequency range. Since the discussion in this paper mainly

concentrates on mm-wave (i.e. 30 GHz and above), very few antennas working in X-band frequency range are discussed here mainly considering the suitability of the antenna for mm-wave communications.

The dual-polarized meta-material enabled horn antenna is used satellite communication in Ku-band [79]. The high gain array of micro-strip antennas are used instead of dish antenna for television reception at 12 GHz [109], [110]. In [110], the full size array uses four sub-arrays each consisting of sixteen comb-lines of forty radiating elements. The printed fractal monopole fed by grounded coplanar waveguide is used for wide-band application over 4.65 – 10.5 GHz [111]. The dielectric resonator antenna fed by T-shaped monopole is used for ultra wide-band communication over 3.1 – 10.6 GHz [112]. The performance of these antennas are summarized in Table 4. The Ku band antennas find important applications in aircraft, spacecraft and satellite-based communication systems [113]. A Ku-band patch antenna loaded with notch and slit is presented in [113]. An interesting microstrip antenna structure consisting of planar monopole with structured ground plane is designed in [114] for microwave imaging over a very wide-band 3 - 18 GHz. T-shaped patch with L-shaped slots on the ground layer and its array is designed in [115] for television broadcasting service in Turkey over Ku-band.

B. K-BAND (18 – 26 GHz)

The k-band (18 – 26 GHz) frequencies are mostly used for radar and satellite communications. This range is also getting considered largely for next generation 5G communication. Pozar presents the results of an aperture-coupled stacked micro-strip antenna for k-band operation in [116]. The numerical results based on the integral equations solved in spectral domain by moment method are compared with experimental results. The bandwidth in excess of 20% is achieved due to the use of thick substrate. However, when integrated in phased array antenna, this structure generates scan blindness problem, which can be adjusted to the location beyond the desired scanning range [116]. A micro-strip-fed endfire angled-dipole antenna is developed in [73] for mm-wave phased array applications in automotive radars and high data-rate communication systems. The antenna shows high radiation efficiency (93%) and low mutual coupling in the frequency range 20 – 26 GHz. In a recent work, sub-arrays of patch antennas are chosen for mobile communication over 21 – 22 GHz [117]. The sub-arrays are arranged along the edge of the mobile phone printed circuit board (PCB) for broad three dimensional scanning coverage with high gain (> 10 dB) beams. The impact of the user's hand on the antenna performance is also investigated. However, the feed network which is an essential block in the design of array antenna is not incorporated in this work.

C. KA-BAND (26.5 – 40 GHz) AND Q-BAND (33 – 50 GHz)

The multi-layer circularly polarized reflectarray antenna is used for Ka-band satellite and radar applications [78].

TABLE 4. Performance summary of reported Mm-wave antennas for different frequency ranges.

Antenna structure	Frequency (GHz)	Material used	Gain (dBi)	Strength	Weakness
Meta-material enabled horn antenna	11 - 18	Dielectric material with relative permittivity=1.96	20	Wide bandwidth, low cross polarization, low side-lobe	Bulky structure, not integrable with solid state devices
Crank-type micro-strip line antenna [109]	12	Rexolite 1422 copper-clad board	29.2	Light-weight and low-profile antenna	Narrow bandwidth
Micro-strip array of travelling wave comb line antenna [110]	11.7 - 12.1	Copper-backed plastic and foam material	35.5	Cheap flat-plate array structure	Feed structure increases overall size
Printed fractal monopole fed by coplanar waveguide [111]	4.65 - 10.5	Rogers RO4003	2 - 4	Wide-band, miniaturized structure	Low gain
Dielectric resonator antenna fed by T-shaped monopole [112]	3.1 - 10.6	Eccostock HI-K	5	Wide-band characteristics	Heavy non-planar structure and complex fabrication process
Patch antenna with notches and slit [113]	12 - 18	Poly-tetra-fluoro-ethylene (PTFE)	6.3	Compact, increased gain and bandwidth	Probe-type feeding not suitable for high frequency
Planar monopole antenna with structured ground plane [114]	3 - 18	Roger RO4003c	6	Compact size, wide bandwidth, wide-band isolation effect	Substrate dispersion, fabrication complexity
T-shaped microstrip patch with H-shaped slot on ground plane [115]	10.7 - 12.7	RO4003 substrate	9.8	High gain, wide bandwidth	High feed-line loss
Aperture-coupled stacked micro-strip antenna [116]	18 - 26	Material with relative permittivity = 2.2	-	Wide-band performance	Thicker substrate causes scan-blindness in phased array
Micro-strip line fed angled dipole antenna [73]	20 - 26	Teflon	2.5	Wide-band, low cross polarization, high efficiency	Appreciable feed-line radiation in array application
Sub-array of micro-strip patch antenna [117]	21 - 22	Nelco N9000 substrate	>10	Good directivity and efficiency	Use of lossy co-axial probe feed
Mesh-grid patch antenna array [118]	28	Cellular phone PCB	24	High gain, miniaturized array structure	Narrow impedance bandwidth
Vivaldi antenna [119]	27.4- 28.6	N9000 PTFE	6	High gain and efficiency, three dimensional beam steering	Appreciable mutual coupling between array elements
U-shaped thin lens [120]	28	FR4 substrate	3.8 dB increase	Low profile, high efficiency, gain enhancement	Narrow bandwidth
Capacitive coupled patch antenna array [121]	24 - 28	Rogers RT5880	27	Wide bandwidth, stable gain, 360 ⁰ coverage	Appreciable mutual coupling
Printed dipole antenna [69]	26 - 38	RT Duroid 5880	4.5 - 5.8	Wide bandwidth, high gain, wide scan angle, low coupling	High cross-polarization level due to undesired feed radiation
Printed twin dipole antenna [122]	30 - 31.5	RT/Duroid 5870	14.4	No use of bonding wire, air bridges or via holes	Limited bandwidth and beam scanning
Multi-layer patch array [123]	37.5 - 38.5	Rogers 5880	19.8 - 21	Reduced size, high gain, wide angular coverage	Narrow bandwidth, loss between feed line and connector
End-fire linearly tapered slot antenna [124]	27.5 - 40	kapton	7	High gain, wide bandwidth, well separated radiating portion and integrated circuit	Lack of information regarding cross-polarized radiation and mutual coupling effects
Planar quasi-yagi antenna [125]	30.5 - 42	Low temperature cofired ceramics (LTCC)	6.3	Wide-band, high gain, good isolation between elements	Limited substrate thickness
Bond-wire antenna [85]	37 - 66	FR408	2	Wide impedance bandwidth, low loss, high efficiency	Frequency range is limited by the dimension of the bond-wire e.g. height and bending angle
Leaky wave antenna using corrugated slab waveguide [93]	40 - 50	Teflon	-	Suitable for integrated circuits, beam steering upto 41 ⁰	Limited scanning rate
Series-fed micro-strip patch antenna array [130]	60	Alumina	12 - 13	Integrable and simple antenna structure	Reduced gain due to chip passivation
Aperture-coupled micro-strip line fed patch antenna [131]	57 - 64	LTCC	15.7 - 18.2	Improved bandwidth and gain	Appreciable mutual coupling between array elements
Slot antenna in ceramic ball grid array (CBGA) package [132] - [133]	59 - 65	LTCC	11	<ul style="list-style-type: none"> • Antenna performance less sensitive to package properties [132] - [133] • Use of low cost, robust wire bonding [133] 	<ul style="list-style-type: none"> • Multi-layer complicated and costly structure [132] • Performance degradation due to bond wire discontinuity [133]
Aperture-coupled patch antenna array [134]	57 - 66	Teflon	17	High gain, wide bandwidth, low mutual coupling, no via	Complicated feed line, greater side-lobe level
Integrated horn antenna [136]	57 - 63	Silicon	14.6	Wide bandwidth, high gain, low dielectric loss	Requirement of proper alignment between multiple layers
Circular stacked patch antenna [137]	57 - 66	FR4	11.6	Wide-band, low cost, no need of grid assembly	Considerable antenna feed line insertion loss
Square patch array [138]	58 - 60, 65 - 68, 72 - 77	Roger RO4003, silicon	9	Multi-band, compact size, low cost, reduced spurious feed radiation	Considerable mutual coupling between array elements

TABLE 4. (Continued.) Performance summary of reported Mm-wave antennas for different frequency ranges.

Antenna structure	Frequency (GHz)	Material used	Gain	Strength	Weakness
Mesh grid patch array [139]	57 - 66	FR-4 PCB substrate	10.9	Highly compact, low profile, low cost	Limited beam scanning range
Rectangular patch with U-slot [140]	54 - 66	RT Duroid 5880	9.5	Wide-band, low profile	High loss due to co-axial probe feed
Electromagnetically coupled micro-strip patch with U-slot array [128]	57 - 64	RT Duroid 5880	15.3	Increased bandwidth, low feed loss and feed radiation	limited scan angle for mutual coupling
Double-slot antenna [141]	62	LTCC	2	Simple, low profile, low-cost structure	Narrow band-width
Linear array of micro-strip patch [142]	59 - 64	LTCC	12.6	Fully integrated filter and antenna	Unwanted surface wave coupling between antenna and other components
End-fire tapered slot antenna [143]	35, 94	Duroid, Kapton	10 - 17	Low side-lobe, high gain	Increase in side-lobe level for thicker substrate
On-chip dipole antenna [54]	77	Silicon	12	Low cost, fully integrated phased array transceiver	Limited impedance bandwidth
Two-dimensional horn antenna with dipole suspended in cavity [144]	93	Silicon wafer	-	Efficient for diffraction-limited imaging	Appreciable mismatch loss between antenna and detector, loss from horn side walls.
Substrate integrated waveguide (SIW) slot array antenna [145]	93 - 96	Rogers 5880	25.8	Narrow beam, high gain Compact, low cost, easy to fabricate structure	Lower efficiency, greater side lobe

The Ka-band is chosen for 5G cellular devices. The design approach and feasibility of a high gain mesh-grid antenna array integrated inside a cellular phone prototype operating at 28 GHz is presented in [118]. The biological implication on the user is also studied. Another interesting antenna structure implemented on PTFE substrate is reported in [119]. The U-shaped thin lens and 1×4 antenna array as feed source is proposed for 28 GHz wireless applications in [120]. The lens antenna maintains angular coverage along the xy-plane which is desired to achieve efficient end-fire radiation. A capacitive coupled patch antenna array designed for mobile phone chassis over 24–28 GHz is presented in [121]. The coaxial probe-type feeding is intelligently used for capacitive coupling and reduction of the effective patch size. A broadband printed dipole antenna angled at 45° and its array are proposed by Ta et al. for 5G cellular networks over 26–38 GHz [69].

The mutual coupling between the array elements is reduced by introducing a stub between the elements. A printed twin dipole phased array antenna is designed avoiding any bonding wire, air bridges or via holes in [122]. The butler matrix is used for multi-beam or switched beam applications in Ka-band [123]. The size of the array is reduced appreciably by assembling the butler matrix underneath the radiators using multilayer structures [123]. An end-fire linearly tapered slot antenna is reported by Yngvesson et al. for 35 GHz [124]. The linear phased array of quasi-yagi antennas is suggested for mobile phone PCB [125]. In some structures, the bond wire is used as antenna to avoid the coupling loss due to external antenna [85], [86]. A compact, wide-band (37–66 GHz), highly efficient bond-wire antenna is presented in [85].

The leaky wave corrugated slab waveguides have found important applications in mm-wave antennas for high resolution radars (40–50 GHz) [93]. This design is found suitable for mm-wave integrated circuits.

A one-dimensional phased array of leaky-wave line-source antennas is used for two-dimensional scanning by Oliner [126]. Negligible cross polarization without any blind spot or grating lobe is achieved using this antenna [126], [127] presents an aperture-coupled micro-strip antenna which includes the study on the effect of feed network consisting of monolithic microwave integrated circuit (MMIC) on the antenna characteristics.

D. 60 GHz BAND (57 – 64 GHz)

As noticed from Table 1, 57 – 64 GHz is used mainly for WiGig and wireless HD applications. The 60 GHz frequency is used for WPAN/WLAN (IEEE 802.15.3c, 802.11ad/ay), wireless backhaul [19] and ISM applications.

Sufficient reported works are found on the antenna development in the 60 GHz frequency [128 – 140]. Kinzel discusses the use of GaAs monolithic microwave integrated circuit (MMIC) technology for phased array design, array architecture and other MMIC issues in this frequency range [129]. A micro-strip array integrated with high electron mobility transistor amplifier on alumina substrate is reported in [130]. The transitions are avoided to reduce the loss. The measured results of an aperture-coupled micro-strip line-fed patch antenna array fabricated on LTCC substrate proves the suitability of standard LTCC process for mm-wave region [131]. The air cavities are introduced inside the substrate to achieve bandwidth and gain improvement (2.5 dB better). The slot antenna array is used in highly integrated 60 GHz radios in [132].

The feasibility of on-chip and antenna-in-package technology for 60 GHz wireless personal area network (WPAN) application is demonstrated in [133]. Several reported works are found on using compact planar patch antenna arrays for unlicensed 60 GHz frequency band [134]. The bandwidth and radiation efficiency are improved by using air-cavity and

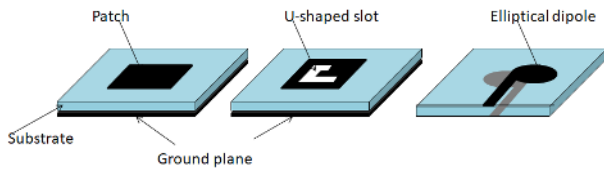

FIGURE 10. Different types of microstrip antennas; (a) rectangular patch antenna; (b) broadband patch antenna with u-shaped slot; (c) elliptical dipole antenna [128].

resonating aperture [134]. Very useful methodologies and measurement results are also presented for understanding the electromagnetic behavior of integrated circuits and on-chip antennas upto 67 GHz in [135].

An integrated horn antenna excited by using an integrated vertical current probe connected with a coplanar waveguide (CPW) is presented in [136].

Hong et al. reports a novel antenna array module designed on standard FR4 HDI PCB material and integrated into 60 GHz transceiver carrier board [137]. The use of low cost material and avoidance of complicated grid array assemblies appreciably reduces the cost of the module. An interesting square patch 1×6 array is reported for multiple bands within 58 – 77 GHz in [138]. The patch antenna is designed on low dielectric Roger substrate to reduce the dielectric loss, whereas silicon is used under the feed network to reduce the size and achieve enhanced bandwidth. The spurious radiation from feed network is restricted by using superstrate material of high dielectric constant.

The design of mm-wave 5G antenna module and its implementation within fully operating cellular handset at the 60 GHz spectrum is presented in [139]. Two types of mesh-grid phased array antennas with reconfigurable horizontal and vertical polarizations are designed, tested and then integrated with rest of the RF and digital architecture. This work demands a very important role in the progress of 5G antenna design technologies. However, further investigation is required to increase the beam scanning range and incorporate spatial diversity.

The performance of several interesting planar antenna structures e.g. micro-strip patch, elliptical dipole and broadband probe-fed micro-strip patch antenna with U-shaped slot [140] is compared for 60 GHz applications in [128] (Figure 10). The antenna structures are simulated and optimized using commercial electromagnetic simulator e.g. CST Microwave Studio. The antennas are designed on RT Duroid 5880 substrate with relative permittivity of 2.2 and thickness of 20 mil. The simulated results show that the impedance bandwidth over 57 – 64 GHz is achieved for micro-strip patch antenna with U-slot. Also the 1×10 array using this antenna shows sufficient gain (15.3 dBi) and good scanning performance over $\pm 60^\circ$ [128]. The performance of micro-strip linearly-fed tapered patch antenna array and probe-fed microstrip comb line array structure are studied in [128] (Figure 11(a) - 11(b)). The arrays show gain of 12 dBi and 9.9 dBi respectively over the 60 GHz band. To avoid the loss due

to co-axial probe feed, the modified antenna structure using electromagnetic coupling type feeding technique is suggested in the present work. Also the bandwidth of the antenna is increased by sandwiching another dielectric layer with properties similar to air between the feed line and the antenna as shown in Figure 11(c). For different excitation phases applied to the antenna elements, the array as shown in Figure 11(d) shows good scan performance upto $\pm 45^\circ$ in the broad-side direction (Figure 12). The corporate-type feed network placed on a different layer i.e. upper layer of the lower dielectric material is suggested to avoid interference with the actual array radiation pattern. The array should be designed including the feed network to estimate the feed line loss.

E. V-BAND (40 – 75 GHZ) AND W-BAND (75 – 110 GHZ)

Interesting antenna structures are presented in [141], [142] for V-band (40 – 75 GHz) applications. An innovative topology implementing three dimensional (3-D) fully integrated filter and antenna as system-on-package is presented in [142]. The investigations on different end-fire tapered slot antennas with linear, exponential, constant-width slots at 35 GHz and 94 GHz are presented in [143]. A fully integrated 77 GHz phased array transceiver using local oscillator (LO) phase shifting scheme is described in [54]. A monolithic two-dimensional horn imaging array for mm-wave frequencies (93 GHz and 242 GHz) is presented in [144]. In [145], a substrate integrated wave-guide (SIW) mono-pulse array is presented for W-band applications. The measured results show high gain around 25.8 dBi with narrow beam-width over 93 – 96 GHz.

The reported works on antenna design for mm-wave applications are summarized in Table 4 according to the frequency ranges.

F. CONCLUDING REMARKS

Overall, the aforementioned developments in the area of mm-wave array antenna over decades offer solutions which approach to the design of efficient array on a substrate chip to achieve greater gain, power and range. This will serve as a solid base for future investigations and offer wide spectrum of applications in the future e.g. vehicular technology, medical applications, IoT, secured communications etc. The survey on the existing literature shows that the radiating structures are judiciously selected to achieve compactness, light weight, minimum power consumption, ease of integrability with other devices, gain and bandwidth requirements according to the specific applications. The planar antenna structures are preferred for the above mentioned properties. Also the substrate materials are chosen keeping in mind the high surface-wave loss and dielectric loss at mm-wave frequencies. In most of the reported works, relatively high cost advanced antenna materials of desired thickness are used to assure the low surface-wave and dielectric loss at the high frequencies (e.g. [120]). Some literature presents antennas using low cost materials to achieve lower Bills of Material (BoM) (e.g. [146]). The performance of the antennas

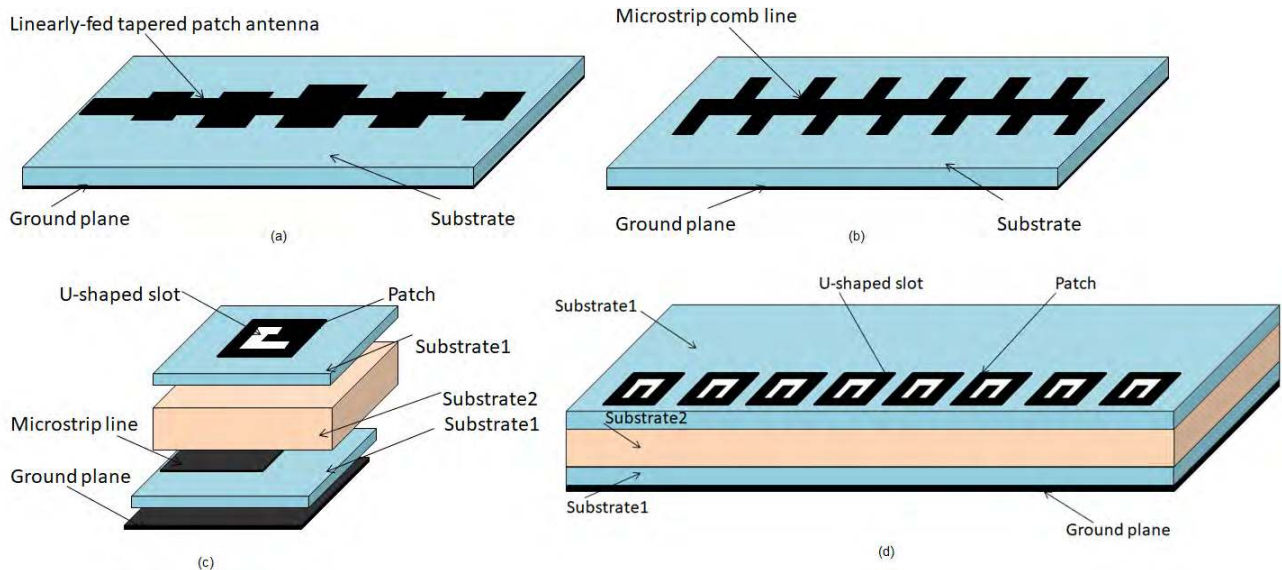

FIGURE 11. (a) Linearly-fed tapered patch antenna; (b) micro-strip comb array antenna; (c) micro-strip patch antenna with U-shaped slot using electromagnetic coupled feed structure; (d) 1×8 linear array of micro-strip patch antenna with U-shaped slot.

are tested and verified for the desired frequency ranges. Sufficient importance is given on the feed arrangement in most of the reported works. The aperture coupled or electromagnetic coupled feed lines are chosen to avoid the spurious radiation from feed lines [123], [131]. The coaxial feed mechanism is avoided in most of the cases to avoid the impedance matching problems. In some antennas, the co-axial probe feeding is used to reduce the size of the antenna [121]. The feed lines are placed in different layer than the antenna structures to avoid the effect of interference of feed radiation with actual antenna radiations [120], [138].

VII. EMERGING RESEARCH TRENDS

The advancement in the design of mm-wave circuits using semiconductor materials and new processes has made the mm-wave solutions as practical and affordable and it is finding all sorts of new uses. In this section, the development of mm-wave antennas and phased arrays for different applications which have received considerable attention in recent years and are expected to be the subject of future investigations are discussed.

A. VEHICULAR APPLICATIONS

The requirement of supporting advanced driving and vehicle safety applications needs the use of increased number of sensors generating higher data rates in the automated vehicles [10]. However, the limited sensing range of most of the sensor technologies limits the automation capability of vehicles. The connected vehicle i.e. employing wireless communications to exchange sensor data between the cars are considered as an alternative to increase the sensing range and improve automated driving functions [147]. The mm-wave communication is suggested as a viable solution to this problem to achieve the desired high data rate.

The design of the suitable directional antenna array for this purpose is an important research area [148]. The antenna that can be integrated within the vehicle is preferred. The presence of other antennas, electronic components and vehicle structure need to be taken into account while designing the antenna [148]. The small size, highly directional antenna, high resolution with low mutual coupling is preferred.

Some important works focusing on the antenna design for connected vehicles are discussed in [148], [149]. Rappaport et al. presents the developments in vehicular radar at 60 GHz and above using low cost integrated antennas [149]. A wideband (25 % bandwidth) air-spaced micro-strip antenna array with 15.5 dBi gain is designed for vehicular communication over 63 – 64 GHz [150]. The suspended antenna technology over substrate with high dielectric constant is used to improve antenna gain and efficiency for 77 GHz automotive applications [151]. The background and overview of state of the art mm-wave technology for automotive radar application including silicon-based fully integrated radar chips are presented in [152]. A 77 GHz antenna array designed on LTCC material is presented in [153] for short-range automotive radar application. The use of ceramic material helps to combine the antenna easily with the IC packages. The laminated wave-guide with high isolation and low loss is used to unify the antenna with the packages. The antenna array also shows high gain, low side-lobe level and wide bandwidth.

Overall, a growing variety of high performance mm-wave sensors are under development for driver assistance systems in semi-autonomous and autonomous mode vehicles. In the coming years, mm-wave will find its way into vehicular applications with high volume production and low cost potential. However, several challenges in mm-wave vehicular technologies e.g. channel modeling, placement of antenna, beam alignments etc. need to be considered.

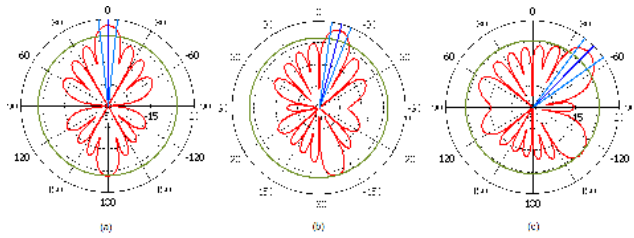

FIGURE 12. Plot of gain pattern of y-directed 1 × 8 array in the broadside direction with $\phi = 90^\circ$ for various main beam directions (a) $\theta_0 = 0^\circ$; (b) $\theta_0 = -15^\circ$; (c) $\theta_0 = -45^\circ$.

B. MEDICAL APPLICATIONS

The mm-wave imaging technique is used in different areas e.g. non-destructive testing and evaluation, tissue diagnosis for medical application, security scanning etc. [154]. The mm-wave provides better resolution and reduced penetration depth compared to microwave imaging due to its shorter wavelength. However, it can penetrate hundreds of micrometers to millimeters into the tissue, which helps to identify the pathological changes in different skin layers or outer tissue layers of organs. The recent developments in the area of integrated circuit technology at affordable cost for mm-wave frequencies, has enabled the use of mm-wave front ends for expensive clinical equipment as well as consumer grade medical applications [154]. Also the downscaling of the near field sensors and antenna interfaces due to shorter wavelengths helps in designing handheld or point-of-care devices. The technical principles of mm-wave tissue sensing are mainly classified in transmission type, reflection type, modulation of transmission line properties and quasi-optical setup [154]. The transmitted and reflected electromagnetic waves depend on the dielectric properties of the tissue materials. The high absorption level at mm-wave frequencies make the measurement of reflection co-efficient more suitable for in vivo applications. The commonly used method for mm-wave tissue diagnosis is the use of near-field probes in direct contact with the sample.

The high-resolution millimeter-wave medical imaging requires the use of very wideband, high-resolution, integrable antenna structure with symmetrical gain pattern for balanced and symmetrical scanning [155].

The most commonly used mm-wave probes are co-axial transmission lines and waveguide probes [156]. To achieve higher resolution, alternate probe designs e.g. tapered waveguide, tapered transmission lines, micro-machined open-ended strip line probes, co-axial lines with an extended inner conductor are used instead of conventional probes [157], [158]. In recent years, the mm-wave has been used for non-invasive blood glucose monitoring using commercial coaxial probe kit [159]. The mm-wave technology is utilized to complement X-ray diagnosis for finding hidden tooth caries [160]. The reflection coefficient of dental caries is measured using pyramidal horn antenna or wave-guide antennas [161]. The permittivity of human skin is measured from RF to terahertz frequencies to diagnose skin cancer using metalized dielectric, micro-machined silicon-core dielectric-rod

TABLE 5. Mm-wave antennas for medical applications.

Antenna structure	Frequency range (GHz)	Application
MEMS probe array consisting of open-ended strip line shielded with walls [165] - [166]	1 - 30	Tumor detection
Modified open-ended rectangular waveguide probe [164]	26.5 - 40	Non-invasive diagnosis of skin burn injuries
Open-end wave-guide, horn antenna [160] - [161]	0.04 - 40, 50 - 75	Tooth decay detection
Co-planar wave-guide [159]	40	Blood glucose measurement
Reconfigurable MEMS-based antenna sensor [158]	45	Non-invasive melanoma skin cancer detection
Open-ended rectangular waveguide [163]	42, 70	Skin cancer detection
Meta-material-based micro-strip patch [167]	60	Medical implant
Metal-dielectric antenna [157]	80	Dermatological and oral imaging
Co-planar waveguide antenna [168]	85	Medical endoscopy
Tapered metallized dielectric [162] - [169]	90 - 104	Test sample of skin tissue

waveguide, open-ended waveguide etc [162], [163] and imaging are used for accurate assessment of burn injury of human skin [164]. Different mm-wave antennas for medical applications [157]–[169] are summarized in Table 5. Future work will concentrate on a single chip transceiver with an even more reduced area by a compact CPW design.

C. IoT APPLICATIONS

The Internet of Things (IoT) is the recent trend in today’s technology. The IoT has found application in different industries e.g. energy, health-care, automotive etc. The requirements for increased speed and bandwidth lead to the use of mm-wave frequencies for IoT applications [170]. The wireless communication is usually the defacto choice for communication between the IoT node devices. The selection of appropriate antenna system is a critical component of the node end smart devices.

High performing IoT requires efficient low-profile antennas providing reliable interference free communications. The requirements for increased power, larger bandwidth, higher gain, ever-shrinking foot-print, reasonable performance in extreme interference condition pose additional design challenges of the antennas. These require the use of multiple antenna technologies e.g. phased arrays, sector antennas, and MIMO signal processing [171].

The phased array antenna is used to communicate with multiple sensors, point-to multi-point connection etc [172]. The energy consumption of the devices is a major challenge in the IoT applications. The backscatter modulation enables ultra-low power communication. A fully functional mm-wave identification (ID) system at frequencies above 70 GHz is presented in [173]. A mm-wave patch antenna with gain of 7 dBi and beam-width of 75° is used for this purpose. An interesting work on Gbps backscatter transmission in the

24 GHz band using low energy, low complexity communication platform is presented in [174]. A 5×1 circularly polarized patch antenna array with gain about 10 dBi is integrated with the front-end circuitry on flexible liquid crystal polymer (LCP) substrate. The flexible substrate allows the integration of the front-end with wearables for 5G mobile and IoT applications.

D. MASSIVE MIMO APPLICATIONS

The massive MIMO system has become a promising technology for communication in recent years. The system uses large antenna arrays at base stations to simultaneously serve many autonomous terminals. The increasing number of antennas in the transmitter/receiver produces more possible signal paths which improves the performance in terms of data rate and link reliability. The placement of huge number of antennas in close vicinity becomes a challenging issue as it causes mutual interference resulting in degradation in MIMO capacity. The higher carrier frequencies are chosen to place more number of antennas in a given antenna aperture [175].

Thus the design of huge array antenna with high gain, reduced size, low loss, low mutual coupling, beam forming capability - all these issues become major challenges in the design of antennas for massive MIMO [176].

The conventional multi-antenna transceiver design in massive MIMO requires to replicate multiple transmit-receive chain for each antenna, which proportionately increase the power consumption, chip area, complexity, interference etc. The use of code modulated path sharing multi-antenna architecture provides a solution to this problem by combining the signals for multiple antenna subsets into a single RF/intermediate frequency (IF)/baseband/analog-to digital converter (ADC) path [177], [178]. For mm-wave MIMO systems, the antennas need to be integrated with the RF front ends. The planar discrete lens array has found applications in generating narrow beams for MIMO [179]. The parasitic antenna arrays are also used to achieve high beam forming gain by controlling the mutual coupling between the elements [180]. An interesting work on the design of dual band, high gain, series fed array of printed slot antenna is presented in [181] for 28/38 GHz MIMO applications. The performance comparison of different planar array antennas e.g. uniform rectangular, hexagonal and circular planar array show same maximum array gain, beamwidth and spectral efficiency while used in three dimensional massive MIMO system [182]. The diversity gain analysis of mm-wave MIMO systems for distributed antenna sub-array architecture is presented in [183]. The fully digital massive MIMO active antenna system for 28 GHz base station application is suggested and experimentally verified in indoor environment in [184]. In near future, the massive MIMO with fully digital transceiver will be available for sub-6 GHz as well as mm-wave frequencies [185]. The massive antenna array can also be used for low-power machine-type or ultra-reliable communications and for non-communication applications such as radar, sensing and positioning [185].

E. OPEN PROBLEMS AND CHALLENGES

There are several challenges in the implementation of mm-wave communications [186]. We focus on the challenges related to the antenna design, which is the major crucial part of physical layer. In this section, we have already discussed the problems and limitations on antenna design for various applications. Here, we emphasize on the overall antenna design complexities in advanced applications at mm-wave frequencies and possible way out of these.

In this context, we have seen that the advancements in CMOS or SiGe technology with transit frequencies of hundreds of gigahertz in recent years motivates the researchers to design low cost and small sized on-chip or in-package antennas [10]. However the important parameters e.g. relative permittivity and loss tangent of these materials at mm-wave frequencies are not provided by the foundries, which induces the designers to measure these important parameters and complicates the antenna design [10]. At mm-wave frequencies, the beam-forming array antenna with closely packed antenna elements are mostly used to direct the signal power spatially and achieve high gain. The mutual coupling between the elements in close proximity indulges additional challenge in antenna design and demands special attention. It is desired to reduce the mutual coupling by some intelligent method e.g. inclusion of stub [69], meta-material [76], [187] between array elements. Also the feed network for the array antenna needs to be selected and included at the very beginning of the design phase of actual array to estimate the effect of feed radiation on the actual pattern. The in-package antennas suffer from adequate loss due to the package interconnects. Again, the electromagnetic interference between the antennas and other circuit components in on-chip antennas plays a very important role in the proper functioning of both the antennas and the circuit components [108]. However, detailed study on this area is lacking in most of the reported works on antenna-in-package (AiP) modules. For accurate estimation of performance of the on-chip antenna, electromagnetic modeling of the antenna including the active and passive components is required.

As already discussed, the electronic beam steering mechanism is preferred over mechanical approach [188]. The electronic beam steering is achieved by incorporating certain phase shifting between the array elements. The conventional methods of phase shifting is 1. introduction of phase shifters connected with the elements and 2. frequency scanning using travelling wave structures with inter-element spacing. At mm-wave frequencies, the phase shifters are quite lossy which decrease the effective antenna gain and hard to implement and presently are not available in the market [188], [189]. Also high losses are associated with the power distribution to each element. In this situation the alternative approach of using travelling wave frequency scanning antenna with limited bandwidth may be devised. Also research should be carried out on the design of high frequency phase shifter or to come up with the advanced antenna design with proper isolation that nullify the loss of phase shifter at high frequency.

The implementation of MIMO techniques is necessary for future mm-wave communication systems. Each antenna of the fully digital MIMO array requires a dedicated RF chain including PA, LNA, ADC/DAC, mixer and other components, which is really challenging in the present scenario [190]. The components e.g. PA and data converters are highly power consuming and costly [191]. The alternative low RF-complex hybrid analog/digital architecture with corresponding signal processing technique needs to evolve [192]. Also, the massive multi antenna technique is to be used to achieve the desired network densification in 5G network [193]. The 3-D beam-forming with the capability of scanning in both horizontal and vertical plane is the key working technology of the massive multi antenna systems. It has envisaged as an important research area in recent years [194]–[196]. This new technology increases the complexity in the antenna design also. This requires to choose more general 3-D array topologies with the array elements placed in both azimuth and vertical plane in different configurations e.g. planar, circular, spherical etc [195]. There are several challenges e.g. placement of large number of antenna elements in close proximity, increased cost and complexity with the increment in the number of RF chains attached with the antennas. However, the major challenge is to determine the pattern shape of the array, since the commonly used pattern synthesis techniques e.g. Fourier-Bessel series [197] to determine the pattern in 3-D space is mostly used for planar, symmetric arrays. Also, the array design methods are applicable for narrow-band systems, which is not desired for the advanced 3-D beam-forming applications. This demands the use of advanced array configurations with wide-band beam shaping design. Recently research has started on antenna array configuration which needs to be explored further in future.

VIII. CONCLUSION

This paper presents an exhaustive survey on the design of array antenna for mm-wave communications. Different array architectures and techniques, important parameters of the array antennas are presented briefly. The evolution of array antennas for mm-wave communications emphasizing the design, promising application areas, benefits and short-comings of the designs are described here. The design of mm-wave antenna has become a crucial issue and found appreciable attention by the researchers. The phased array antenna is chosen for mm-wave communication due to its ability to produce directive beam with high gain in desired direction by changing the excitation phase of the array elements to combat the high path loss at mm-wave frequencies. However, there are various design challenges - e.g. choice of antenna/array structure, method of beam scanning, feed structures, integration of RF front-end with the antennas, mutual coupling between array elements, electromagnetic interference between the electronic circuits in the front-end and antenna etc. For mm-wave applications, extra care should

be given on the selection of antenna elements, material properties, mutual coupling, feed radiation loss etc. The antenna performance needs to be evaluated in terms of gain, radiation pattern, impedance bandwidth etc. From the survey of the reported works of the last five decades, it is noticed that though different types of regular and irregular array architectures are used for various applications, the good old regular rectangular array suits well for most of the cases. Also the planar antenna elements are preferred for most of the applications due to their properties e.g. low profile, light weight, ease of integration with other components on the same substrate etc. The corporate feeding is a reliable and proven technique for the array feeding. However, there is a quest for antenna element and array structure with smaller size, high directivity, reduced loss, low mutual coupling, low price etc. Also the antenna element with feed network needs to be designed as a whole to understand the loss mechanism and estimate the actual system performance before fabrication. The mm-wave technology has become an affordable and practical solution to various application areas due to the recent developments in the field of low-cost materials and integrated-circuit designs. Mm-wave is successfully implemented for vehicle to everything (V2X) communications. For efficient mm-wave phased array design for this purpose, the channel modeling, antenna placement, beam alignments etc. need to be taken care of. Overall, it is evident from the survey that the mm-wave array antenna has an enormous potential to be implemented in various application areas e.g. medical imaging, IoT, massive MIMO, 3-D beam-forming etc. In view of the upcoming applications, antenna design needs to be revisited for the actual system design.

REFERENCES

- [1] M. El-kashlan, T. Q. Duong, and H.-H. Chen, "Millimeter-wave communications for 5G: Fundamentals: Part I [Guest Editorial]," *IEEE Commun. Mag.*, vol. 52, no. 9, pp. 52–54, Sep. 2014.
- [2] Y. Niu, Y. Li, D. Jin, L. Su, and A. V. Vasilakos, "A survey of millimeter wave communications (mmWave) for 5G: Opportunities and challenges," *Wireless Netw.*, vol. 21, no. 8, pp. 2657–2676, Nov. 2015.
- [3] C. H. Doan, S. Emami, D. A. Sobel, A. M. Niknejad, and R. W. Brodersen, "Design considerations for 60 GHz CMOS radios," *IEEE Commun. Mag.*, vol. 42, no. 12, pp. 132–140, Dec. 2004.
- [4] T. S. Rappaport, J. N. Murdock, and F. Gutierrez, Jr., "State of the art in 60-GHz integrated circuits and systems for wireless communications," *Proc. IEEE*, vol. 99, no. 8, pp. 1390–1436, Aug. 2011.
- [5] G. R. Hiertz, D. Denteneer, L. Stibor RWTH Aachen University, L. Stibor, Y. Zang, X. P. Costa, and B. Walke, "The IEEE 802.11 universe," *IEEE Commun. Mag.*, vol. 48, no. 1, pp. 62–70, Jan. 2010.
- [6] J. P. Gilb, "IEEE standards 802.15. 3c - part 15.3: Wireless medium access control (MAC) and physical layer (PHY) specifications for high rate wireless personal area networks (wpans) amendment 2: Millimeter-wave-based alternative physical layer extension," *IEEE Comput. Soc.*, to be published.
- [7] T. S. Rappaport, S. Sun, R. Mayzus, H. Zhao, Y. Azar, K. Wang, G. N. Wong, J. K. Schulz, M. Samimi, and F. Gutierrez, "Millimeter wave mobile communications for 5G cellular: It will work!" *IEEE Access*, vol. 1, pp. 335–349, May 2013.
- [8] W. Hong, Z. H. Jiang, C. Yu, J. Zhou, P. Chen, Z. Yu, H. Zhang, B. Yang, X. Pang, M. Jiang, and Y. Cheng, "Multibeam antenna technologies for 5G wireless communications," *IEEE Trans. Antennas Propag.*, vol. 65, no. 12, pp. 6231–6249, Dec. 2017.

- [9] M. J. Marcus, "5G and 'IMT for 2020 and beyond' [spectrum policy and regulatory issues]," *IEEE Wireless Commun.*, vol. 22, no. 4, pp. 2–3, Aug. 2015.
- [10] T. S. Rappaport, R. W. Heath Jr, R. C. Daniels, and J. N. Murdock, *Millimeter Wave Wireless Communications*. London, U.K.: Pearson Education, 2014.
- [11] H. Yang, M. H. A. J. Herben, I. J. A. G. Akkermans, and P. F. M. Smulders, "Impact analysis of directional antennas and multi-antenna beamformers on radio transmission," *IEEE Trans. Veh. Technol.*, vol. 57, no. 3, pp. 1695–1707, May 2008.
- [12] O. Blumtritt, *Technical and Military Imperatives: A Radar History of World War 2*. Baltimore, MD, USA: The Johns Hopkins Univ. Press, 2001.
- [13] R. L. Haupt and Y. Rahmat-Samii, "Antenna array developments: A perspective on the past, present and future," *IEEE Antennas Propag. Mag.*, vol. 57, no. 1, pp. 86–96, Feb. 2015.
- [14] J. S. Herd and M. D. Conway, "The evolution to modern phased array architectures," *Proc. IEEE*, vol. 104, no. 3, pp. 519–529, Mar. 2016.
- [15] I. Uchendu and J. R. Kelly, "Survey of beam steering techniques available for millimeter wave applications," *Prog. Electromagn. Res. B*, vol. 68, pp. 35–54, May 2016.
- [16] S. Kuttty and D. Sen, "Beamforming for millimeter wave communications: An inclusive survey," *IEEE Commun. Surveys Tuts.*, vol. 18, no. 2, pp. 949–973, 2nd Quart., 2016.
- [17] S. A. Busari, K. M. S. Huq, S. Mumtaz, L. Dai, and J. Rodriguez, "Millimeter-wave massive MIMO communication for future wireless systems: A survey," *IEEE Commun. Surveys Tuts.*, vol. 20, no. 2, pp. 836–869, 2nd Quart., 2018.
- [18] V. Va, T. Shimizu, G. Bansal, and R. W. Heath, Jr., "Millimeter wave vehicular communications: A survey," *Found. Trends Netw.*, vol. 10, no. 1, pp. 1–113, Jun. 2016.
- [19] *White Paper on 60 GHz Communications, V1.1.0*, TSDSI, India, 2018. [Online]. Available: <http://www.tdsi.in>
- [20] C. A. Fowler, "Old radar types never die; They just phased array or... 55 years of trying to avoid mechanical scan," *IEEE Aerosp. Electron. Syst. Mag.*, vol. 13, no. 9, pp. 24A–24L, Sep. 1998.
- [21] L. Stark, "Microwave theory of phased-array antennas—A review," *Proc. IEEE*, vol. 62, no. 12, pp. 1661–1701, Dec. 1974.
- [22] D. K. Cheng, "Optimization techniques for antenna arrays," *Proc. IEEE*, vol. 59, no. 12, pp. 1664–1674, Dec. 1971.
- [23] R. Elliott, "Beamwidth and directivity of large scanning arrays," *Microw. J.*, vol. 6, pp. 53–60, Dec. 1963.
- [24] R. J. Mailloux, *Phased Array Antenna Handbook*, vol. 2. Norwood, MA, USA: Artech House, 2005.
- [25] E. Sharp, "A triangular arrangement of planar-array elements that reduces the number needed," *IRE Trans. Antennas Propag.*, vol. 9, no. 2, pp. 126–129, Mar. 1961.
- [26] D. Parker and D. C. Zimmermann, "Phased arrays—Part 1: Theory and architectures," *IEEE Trans. Microw. Theory Techn.*, vol. 50, no. 3, pp. 678–687, Mar. 2002.
- [27] N. H. Noordin, V. Zuniga, A. O. El-Rayis, N. Haridas, A. T. Erdogan, and T. Arslan, "Uniform circular arrays for phased array antenna," in *Proc. Loughborough Antennas Propag. Conf.*, Nov. 2011, pp. 1–4.
- [28] P. Rocca, G. Oliveri, R. J. Mailloux, and A. Massa, "Unconventional phased array architectures and design methodologies—A review," *Proc. IEEE*, vol. 104, no. 3, pp. 544–560, Mar. 2016.
- [29] I. E. Lager, C. Trampuz, M. Simeoni, and L. P. Ligthart, "Interleaved array antennas for FMCW radar applications," *IEEE Trans. Antennas Propag.*, vol. 57, no. 8, pp. 2486–2490, Aug. 2009.
- [30] A. F. Morabito, T. Isernia, M. G. Labate, M. D'Urso, and O. M. Bucci, "Direct radiating arrays for satellite communications via aperiodic tilings," *Prog. Electromagn. Res.*, vol. 93, pp. 107–124, 2009.
- [31] P. Rocca, M. D'Urso, and L. Poli, "Advanced strategy for large antenna array design with subarray-only amplitude and phase contro," *IEEE Antennas Wireless Propag. Lett.*, vol. 13, pp. 91–94, 2014.
- [32] Y. Lo, "A mathematical theory of antenna arrays with randomly spaced elements," *IEEE Trans. Antennas Propag.*, vol. AP-12, no. 3, pp. 257–268, May 1964.
- [33] M. Donelli, A. Martini, and A. Massa, "A hybrid approach based on PSO and Hadamard difference sets for the synthesis of square thinned arrays," *IEEE Trans. Antennas Propag.*, vol. 57, no. 8, pp. 2491–2495, Aug. 2009.
- [34] J. Lu and Y. Guo, "Compact planar sparse array antenna with optimum element dimensions for satcom ground terminals," *Int. J. Antennas Propag.*, vol. 2015, Dec. 2015, Art. no. 806981.
- [35] X. Zhuge and A. G. Yarovoy, "Sparse multiple-input multiple-output arrays for high-resolution near-field ultra-wideband imaging," *IET Microw., Antennas Propag.*, vol. 5, no. 13, pp. 1552–1562, Oct. 2011.
- [36] R. Tang, "Practical aspects of phased array design," in *Antenna Handbook*. New York, NY, USA: Springer, 1988, pp. 1283–1312.
- [37] H. Iizuka, T. Watanabe, K. Sato, and K. Nishikawa, "Millimeter-wave microstrip array antenna for automotive radars," *IEICE Trans. Commun.*, vol. 86, no. 9, pp. 2728–2738, Sep. 2003.
- [38] S. E. Alavi, M. R. K. Soltanian, I. S. Amiri, M. Khalily, A. S. M. Supa'at, and H. Ahmad, "Towards 5G: A photonic based millimeter wave signal generation for applying in 5G access fronthaul," *Sci. Rep.*, vol. 6, Jan. 2016, Art. no. 19891.
- [39] Y. Hayashi, K. Sakakibara, M. Nanjo, S. Sugawa, N. Kikuma, and H. Hirayama, "Millimeter-wave microstrip comb-line antenna using reflection-canceling slit structure," *IEEE Trans. Antennas Propag.*, vol. 59, no. 2, pp. 398–406, Feb. 2011.
- [40] K. Sakakibara, S. Sugawa, N. Kikuma, and H. Hirayama, "Millimeter-wave microstrip array antenna with matching-circuit-integrated radiating elements for travelling-wave excitation," in *Proc. 4th Eur. Conf. Antennas Propag.*, Apr. 2010, pp. 1–5.
- [41] K. Sakakibara, Y. Hayashi, N. Kikuma, and H. Hirayama, "Two-dimensional array design techniques of millimeter-wave microstrip comb-line antenna array," *Radio Sci.*, vol. 43, no. 4, pp. 1–4, Aug. 2008.
- [42] A. Abbaspour-Tamijani and K. Sarabandi, "An affordable millimeter-wave beam-steerable antenna using interleaved planar subarrays," *IEEE Trans. Antennas Propag.*, vol. 51, no. 9, pp. 2193–2202, Sep. 2003.
- [43] M. Li and K.-M. Luk, "Low-cost wideband microstrip antenna array for 60-GHz applications," *IEEE Trans. Antennas Propag.*, vol. 62, no. 6, pp. 3012–3018, Jun. 2014.
- [44] A. Rida, M. Tentzeris, and S. Nikolaou, "Design of low cost microstrip antenna arrays for mm-Wave applications," in *Proc. IEEE Int. Symp. Antennas Propag. (APSURSI)*, Jul. 2011, pp. 2071–2073.
- [45] S. Anderson, M. Millnert, M. Viberg, and B. Wahlberg, "An adaptive array for mobile communication systems," *IEEE Trans. Veh. Technol.*, vol. 40, no. 1, pp. 230–236, Feb. 1991.
- [46] C. Tai, "The optimum directivity of uniformly spaced broadside arrays of dipoles," *IEEE Trans. Antennas Propag.*, vol. AP-12, no. 4, pp. 447–454, Jul. 1964.
- [47] X. Wang and A. Stelzer, "79-GHz LTCC RF-frontend deploying 45 degree linear-polarized vertical parallel-feed antennas," in *Proc. IEEE MTT-S Int. Conf. Microw. Intell. Mobility (ICMIM)*, Apr. 2015, pp. 1–4.
- [48] Y. T. Lo and S. Lee, *Antenna Handbook—Volume III Applications*. New York, NY, USA: Springer, 2012.
- [49] J. Chen, *Advanced Architectures for Efficient mm-Wave CMOS Wireless Transmitters*. Berkeley, CA, USA: University California, 2013.
- [50] X. Yang, M. Matthaiou, J. Yang, C.-K. Wen, F. Gao, and S. Jin, "Hardware-constrained millimeter-wave systems for 5G: Challenges, opportunities, and solutions," *IEEE Commun. Mag.*, vol. 57, no. 1, pp. 44–50, Jan. 2019.
- [51] A. Natarajan, S. K. Reynolds, M. D. Tsai, S. T. Nicolson, J.-H. C. Zhan, D. G. Kam, D. Liu, Y.-L. O. Huang, A. Valdes-Garcia, and B. A. Floyd, "A fully-integrated 16-element phased-array receiver in SiGe BiCMOS for 60-GHz communications," *IEEE J. Solid-State Circuits*, vol. 46, no. 5, pp. 1059–1075, May 2011.
- [52] S.-S. Jeon, Y. Wang, Y. Qian, and T. Itoh, "A novel smart antenna system implementation for broad-band wireless communications," *IEEE Trans. Antennas Propag.*, vol. 50, no. 5, pp. 600–606, May 2002.
- [53] M. Tabesh, J. Chen, C. Marcu, L. Kong, S. Kang, E. Alon, A. Niknejad, "A 65 nm CMOS 4-element Sub-34 mW/element 60GHz phased-array transmitter," *IEEE J. Solid-State Circuits*, vol. 46, no. 12, pp. 3018–3032, Dec. 2011.
- [54] A. Natarajan, A. Komijani, X. Guan, A. Babakhani, and A. Hajimiri, "A 77-GHz phased-array transmitter with on-chip antennas in silicon: Transmitter and local lo-path phase shifting," *IEEE J. Solid-State Circuits*, vol. 41, no. 12, pp. 2807–2819, Dec. 2006.
- [55] X. Guan, H. Hashemi, and A. Hajimiri, "A fully integrated 24-GHz eight-element phased-array receiver in silicon," *IEEE J. Solid-State Circuits*, vol. 39, no. 12, pp. 2311–2320, Dec. 2004.
- [56] R. J. Mailloux, "Array grating lobes due to periodic phase, amplitude, and time delay quantization," *IEEE Trans. Antennas Propag.*, vol. 32, no. 12, pp. 1364–1368, Dec. 1984.

- [57] L. Manica, P. Rocca, and A. Massa, "Design of subarrayed linear and planar array antennas with SLL control based on an excitation matching approach," *IEEE Trans. Antennas Propag.*, vol. 57, no. 6, pp. 1684–1691, Jun. 2009.
- [58] E. Brookner, "Recent developments and future trends in phased arrays," in *Proc. IEEE Int. Symp. Phased Array Syst. Technol.*, Oct. 2013, pp. 43–53.
- [59] P. Rocca, R. L. Haupt, and A. Massa, "Sidelobe reduction through element phase control in uniform subarrayed array antennas," *IEEE Antennas Wireless Propag. Lett.*, vol. 8, pp. 437–440, 2009.
- [60] S. M. Duffy, D. D. Santiago, and J. S. Herd, "Design of overlapped subarrays using an RFIC beamformer," in *Proc. IEEE Antennas Propag. Soc. Int. Symp.*, Jun. 2007, pp. 1949–1952.
- [61] A. P. Goffier, M. Kam, and P. R. Herzfeld, "Design of phased arrays in terms of random subarrays," *IEEE Trans. Antennas Propag.*, vol. 42, no. 6, pp. 820–826, Jun. 1994.
- [62] I. Groger, W. Sander, and W. Wirth, "Experimental phased array radar ELRA with extended flexibility," in *Proc. IEEE Int. Conf. Radar*, May 1990, pp. 286–290.
- [63] W. Chappell and C. Fulton, "Digital Array Radar panel development," in *Proc. IEEE Int. Symp. Phased Array Syst. Technol.*, Oct. 2010, pp. 50–60.
- [64] W. Rotman and R. F. Turner, "Wide-angle microwave lens for line source applications," *IEEE Trans. Antennas Propag.*, vol. 11, no. 6, pp. 623–632, Nov. 1963.
- [65] D. Ehyai, *Novel Approaches to the Design of Phased Array Antennas*. Ann Arbor, MI, USA: Univ. of Michigan Press, 2011.
- [66] M. I. Skolnik, J. Sherman, III, and F. Ogg, Jr., "Statistically designed density-tapered arrays," *IEEE Trans. Antennas Propag.*, vol. 12, no. 4, pp. 408–417, Jul. 1964.
- [67] C. A. Balanis, *Antenna Theory: Analysis and Design*. Hoboken, NJ, USA: Wiley, 1997.
- [68] H. Oraizi and B. Rezaei, "Improvement of antenna radiation efficiency by the suppression of surface waves," *J. Electromagn. Anal. Appl.*, vol. 3, no. 3, p. 79, Mar. 2011.
- [69] S. X. Ta, H. Choo, and I. Park, "Broadband printed-dipole antenna and its arrays for 5G applications," *IEEE Antennas Wireless Propag. Lett.*, vol. 16, pp. 2183–2186, 2017.
- [70] J. Zhang, X. Ge, Q. Li, M. Guizani, and Y. Zhang, "5G millimeter-wave antenna array: Design and challenges," *IEEE Wireless Commun.*, vol. 24, no. 2, pp. 106–112, Apr. 2017.
- [71] T. A. Milligan, *Modern Antenna Design*. Hoboken, NJ, USA: Wiley, 2005.
- [72] F. Khoutar, M. Aznabet, and O. E. Mrabet, "Gain and directivity enhancement of a rectangular microstrip patch antenna using a single layer metamaterial superstrate," in *Proc. 6th Int. Conf. Multimedia Comput. Syst. (ICMCS)*, May 2018, pp. 1–4.
- [73] R. A. Alhalabi and G. M. Rebeiz, "High-efficiency angled-dipole antennas for millimeter-wave phased array applications," *IEEE Trans. Antennas Propag.*, vol. 56, no. 10, pp. 3136–3142, Oct. 2008.
- [74] S. P. Williams and L. E. Corey, "Mechanisms that contribute to the far-field polarization properties of phased-array antennas," in *Dig. Antennas Propag. Soc. Int. Symp.*, Jun. 1989, pp. 412–415.
- [75] A. Farahbakhsh, S. Mohanna, S. Tavakoli, and M. O. Sadegh, "New patch configurations to reduce the mutual coupling in microstrip array antenna," in *Proc. Loughborough Antennas Propag. Conf.*, Nov. 2009, pp. 469–472.
- [76] R. Hafezifard, M. Naser-Moghadasi, J. R. Mohassel, and R. A. Sadeghzadeh, "Mutual coupling reduction for two closely spaced meander line antennas using metamaterial substrate," *IEEE Antennas Wireless Propag. Lett.*, vol. 15, pp. 40–43, 2016.
- [77] E. L. Holzman, "Transreflector antenna design for millimeter-wave wireless links," *IEEE Antennas Propag. Mag.*, vol. 47, no. 5, pp. 9–22, Oct. 2005.
- [78] A. Mahmoud, A. A. Kishk, Z. Hao, and W. Hong, "Ka-band circularly polarized reflectarray: Using a double-layers cross slot," *IEEE Antennas Propag. Mag.*, vol. 58, no. 4, pp. 60–68, Aug. 2016.
- [79] Q. Wu, C. P. Scarborough, B. G. Martin, R. K. Shaw, D. H. Werner, E. Lier, and X. Wang, "A K_u -band dual polarization hybrid-mode horn antenna enabled by printed-circuit-board metasurfaces," *IEEE Trans. Antennas Propag.*, vol. 61, no. 3, pp. 1089–1098, Mar. 2012.
- [80] Y. P. Zhang and D. Liu, "Antenna-on-chip and antenna-in-package solutions to highly integrated millimeter-wave devices for wireless communications," *IEEE Trans. Antennas Propag.*, vol. 57, no. 10, pp. 2830–2841, Oct. 2009.
- [81] F. K. Scherwing, "Millimeter wave antennas," *Proc. IEEE*, vol. 80, no. 1, pp. 92–102, Jan. 1992.
- [82] F. Scherwing and A. Oliner, "Millimeter-wave antennas," in *Antenna Handbook*. New York, NY, USA: Springer, 1993, pp. 1–148.
- [83] N. Camilleri and B. Bayraktaroglu, "Monolithic millimeter-wave IMPATT oscillator and active antenna," *IEEE Trans. Microw. Theory Techn.*, vol. 36, no. 12, pp. 1670–1676, Dec. 1988.
- [84] M. Weiss, "Microstrip antennas for millimeter waves," *IEEE Trans. Antennas Propag.*, vol. 29, no. 1, pp. 171–174, Jan. 1981.
- [85] Y. Ma, K. Kawasaki, and H. Masuda, "A wideband bond-wire antenna for millimeter wave intra-communication systems," *IEEE Trans. Antennas Propag.*, vol. 61, no. 9, pp. 4839–4843, Sep. 2013.
- [86] H. T. Wu, M. Tekle, C. S. Nallani, and N. Zhang, "Bond wire antenna/feed for operation near 60 GHz," *IEEE Trans. Microw. Theory Techn.*, vol. 57, no. 12, pp. 2966–2972, Dec. 2009.
- [87] W. H. Chen, S. Joo, S. Sayilir, R. Willmot, T. Y. Choi, D. Kim, J. Lu, D. Peroulis, and B. Jung, "A 6-Gb/s wireless inter-chip data link using 43-GHz transceivers and bond-wire antennas," *IEEE J. Solid-State Circuits*, vol. 44, no. 10, pp. 2711–2721, Oct. 2009.
- [88] D. M. Pozar, "Considerations for millimeter wave printed antennas," *IEEE Trans. Antennas Propag.*, vol. 31, no. 5, pp. 740–747, Sep. 1983.
- [89] A. Sabban, "Applications of MM wave microstrip Antenna arrays," in *Proc. Int. Symp. Signals, Syst. Electron.*, Aug. 2007, pp. 119–122.
- [90] K. Pitra and Z. Raida, "Planar millimeter-wave antennas: A comparative study," *Radioengineering*, vol. 20, no. 1, pp. 263–269, Apr. 2011.
- [91] T. Itoh and B. Adelseck, "Trapped image guide leaky-wave antennas for millimeter wave applications," *IEEE Trans. Antennas Propag.*, vol. 30, no. 3, pp. 505–509, May 1982.
- [92] A. A. Vertiy, S. P. Gavrilov, V. N. Stepanyuk, and A. O. Salman, "mm-wave radiation by the undulator type wire antennas," in *Proc. 29th Int. Conf.*, Oct. 2004, pp. 695–696.
- [93] H. Maheri, M. Tsutsumi, and N. Kumagai, "Experimental studies of magnetically scannable leaky-wave antennas having a corrugated ferrite slab/dielectric layer structure," *IEEE Trans. Antennas Propag.*, vol. 36, no. 7, pp. 911–917, Jul. 1988.
- [94] T. Zwick, A. Chandrasekhar, C. W. Baks, U. R. Pfeiffer, S. Brebels, and B. P. Gaucher, "Determination of the complex permittivity of packaging materials at millimeter-wave frequencies," *IEEE Trans. Microw. Theory Techn.*, vol. 54, no. 3, pp. 1001–1010, Mar. 2006.
- [95] U. R. Pfeiffer, J. Grzyb, D. Liu, B. Gaucher, T. Beukema, B. A. Floyd, and S. K. Reynolds, "A chip-scale packaging technology for 60-GHz wireless chipsets," *IEEE Trans. Microw. Theory Techn.*, vol. 54, no. 8, pp. 3387–3397, Aug. 2006.
- [96] I. Rana and N. Alexopoulos, "Current distribution and input impedance of printed dipoles," *IEEE Trans. Antennas Propag.*, vol. 29, no. 1, pp. 99–105, Jan. 1981.
- [97] J. C. Rautio and V. Demir, "Microstrip conductor loss models for electromagnetic analysis," *IEEE Trans. Microw. Theory Techn.*, vol. 51, no. 3, pp. 915–921, Mar. 2003.
- [98] H. Rajagopalan and Y. Rahmat-Samii, "Dielectric and conductor loss quantification for microstrip reflectarray: Simulations and measurements," *IEEE Trans. Antennas Propag.*, vol. 56, no. 4, pp. 1192–1196, Apr. 2008.
- [99] J. R. Baker-Jarvis, M. D. Janezic, B. F. Riddle, C. L. Holloway, N. G. Paulter, Jr., and J. Blendell, "Dielectric and conductor-loss characterization and measurements on electronic packaging materials," NIST Nat. Inst. Standards Technol., Gaithersburg, MD, USA, NIST Tech. Note, 2001, vol. 1520.
- [100] D. Liu and B. Gaucher, "Design considerations for millimeter wave antennas within a chip package," in *Proc. Int. Workshop Anti-Counterfeiting, Secur. Identificat. (ASID)*, Apr. 2007, pp. 13–17.
- [101] R. F. Harrington, *Time-Harmonic Electromagnetic Fields*. New York, NY, USA: McGraw-Hill, 1961.
- [102] D. Pozar and D. Schaubert, "Scan blindness in infinite phased arrays of printed dipoles," *IEEE Trans. Antennas Propag.*, vol. AP-32, no. 6, pp. 602–610, Jun. 1984.
- [103] N. Alexopoulos and I. E. Rana, "Mutual impedance computation between printed dipoles," *IEEE Trans. Antennas Propag.*, vol. AP-29, no. 1, pp. 106–111, Jan. 1981.
- [104] M. M. Nikolic, A. R. Djordjevic, and A. Nehorai, "Microstrip antennas with suppressed radiation in horizontal directions and reduced coupling," *IEEE Trans. Antennas Propag.*, vol. 53, no. 11, pp. 3469–3476, Nov. 2005.

- [105] Y. Horii and M. Tsutsumi, "Harmonic control by photonic bandgap on microstrip patch antenna," *IEEE Microw. Guided Wave Lett.*, vol. 9, no. 1, pp. 13–15, Jan. 1999.
- [106] H. Liu, Z. Li, X. Sun, and J. Mao, "Harmonic suppression with photonic bandgap and defected ground structure for a microstrip patch antenna," *IEEE Microw. Wireless Compon. Lett.*, vol. 15, no. 2, pp. 55–56, Feb. 2005.
- [107] E. Levine, G. Malamud, S. Shtrikman, and D. Treves, "A study of microstrip array antennas with the feed network," *IEEE Trans. Antennas Propag.*, vol. 37, no. 4, pp. 426–434, Apr. 1989.
- [108] E. Brookner, "Antenna array fundamentals, part 1," in *Practical Phased-array Antenna Systems*. Norwood, MA, USA: Artech House, 1991, pp. 1–2.
- [109] S. Nishimura, Y. Sugio, and T. Makimoto, "Crank-type circularly polarized microstrip line antenna," in *Proc. Antennas Propag. Soc. Int. Symp.*, vol. 21, May 1983, pp. 162–165.
- [110] A. Henderson and J. R. James, "Improved microstrip flat-plate array for domestic DBS reception," in *Proc. Antennas Propag. Soc. Int. Symp.*, vol. 24, Jun. 1986, pp. 565–568.
- [111] M. N. Jahromi, A. Falahati, and R. M. Edwards, "Bandwidth and impedance-matching enhancement of fractal monopole antennas using compact grounded coplanar waveguide," *IEEE Trans. Antennas Propag.*, vol. 59, no. 7, pp. 2480–2487, Jul. 2011.
- [112] S. Ghosh and A. Chakrabarty, "Ultrawideband performance of dielectric loaded T-shaped monopole transmit and receive antenna/EMI sensor," *IEEE Antennas Wireless Propag. Lett.*, vol. 7, pp. 358–361, 2008.
- [113] P. C. Prasad and N. Chatteraj, "Design of compact Ku band microstrip antenna for satellite communication," in *Proc. Int. Conf. Commun. Signal Process.*, Apr. 2013, pp. 196–200.
- [114] A. D. Capobianco, M. S. Khan, M. Caruso, and A. Bevilacqua, "3-18 GHz compact planar antenna for short-range radar imaging," *Electron. Lett.*, vol. 50, no. 14, pp. 1016–1018, Jul. 2014.
- [115] M. Gokten, L. Kuzu, A. F. Yagli, S. Gulgonul, and E. Demircioglu, "A planar ku band antenna for satellite communications," in *Proc. IEEE/ACES Int. Conf. Wireless Inf. Technol.*, Mar. 2016, pp. 1–2.
- [116] D. M. Pozar and F. Croq, "Millimeter-wave design of wide-band aperture-coupled stacked microstrip antennas," *IEEE Trans. Antennas Propag.*, vol. 39, no. 12, pp. 1770–1776, Dec. 1991.
- [117] N. Ojaroudiparchin, M. Shen, S. Zhang, and G. F. Pedersen, "A switchable 3-D-coverage-phased array antenna package for 5G mobile terminals," *IEEE Antennas Wireless Propag. Lett.*, vol. 15, pp. 1747–1750, Feb. 2016.
- [118] W. Hong, K.-H. Baek, Y. Lee, Y. Kim, and S.-T. Ko, "Study and prototyping of practically large-scale mmWave antenna systems for 5G cellular devices," *IEEE Commun. Mag.*, vol. 52, no. 9, pp. 63–69, Sep. 2014.
- [119] N. Ojaroudiparchin, M. Shen, and G. F. Pedersen, "Design of Vivaldi antenna array with end-fire beam steering function for 5G mobile terminals," in *Proc. 23rd Telecommun. Forum Telfor (TELFOR)*, Nov. 2015, pp. 587–590.
- [120] E. Kim, S. T. Ko, Y. J. Lee, and J. Oh, "Millimeter-wave tiny lens antenna employing U-shaped filter arrays for 5G," *IEEE Antennas Wireless Propag. Lett.*, vol. 17, no. 5, pp. 845–848, May 2018.
- [121] M. Stanley, Y. Huang, H. Wang, H. Zhou, A. Alieldin, and S. Joseph, "A novel mm-Wave phased array antenna with 360° coverage for 5G smartphone applications," in *Proc. 10th UK-Eur.-China Workshop Millimetre Waves THz. Technol. (UCMMT)*, Sep. 2017, pp. 1–3.
- [122] Y.-H. Suh and K. Chang, "A new millimeter-wave printed dipole phased array antenna using microstrip-fed coplanar stripline tee junctions," *IEEE Trans. Antennas Propag.*, vol. 52, no. 8, pp. 2019–2026, Aug. 2004.
- [123] Y. Cao, K.-S. Chin, W. Che, W. Yang, and E. S. Li, "A compact 38 GHz multibeam antenna array with multifolded butler matrix for 5G applications," *IEEE Antennas Wireless Propag. Lett.*, vol. 16, pp. 2996–2999, 2017.
- [124] K. S. Yngvesson, T. L. Korzeniowski, Y. S. Kim, E. L. Kollberg, and J. F. Johansson, "The tapered slot antenna—a new integrated element for millimeter-wave applications," *IEEE Trans. Mobile Comput.*, vol. 37, no. 2, pp. 365–374, Feb. 1989.
- [125] T.-C. Huang, Y.-W. Hsu, and Y.-C. Lin, "End-fire Quasi-Yagi antennas with pattern diversity on LTCC technology for 5G mobile communications," in *Proc. IEEE Int. Symp. Radio-Freq. Integr. Technol. (RFIT)*, Aug. 2016, pp. 1–3.
- [126] A. A. Oliner, "A new class of scannable millimeter-wave antennas," in *Proc. 20th Eur. Microw. Conf.*, vol. 1, Sep. 1990, pp. 95–104.
- [127] H. Ohmine and M. Matsunaga, "A design and fabrication of millimeter-wave microstrip antenna with monolithic microwave integrated circuits," *Electron. Commun. Jpn.*, vol. 78, no. 3, pp. 39–48, 1995.
- [128] S. Ghosh and D. Sen, "Design of millimeter-wave microstrip antenna array for 5G communications—A comparative study," in *Proc. Int. Conf. Intell. Syst. Design Appl.*, 2017, pp. 952–960.
- [129] J. Kinzel, "GaAs technology for millimeter-wave phased arrays," *IEEE Antennas Propag. Soc. Newslett.*, vol. APSN-29, no. 1, pp. 11–14, Feb. 1987.
- [130] C. Karnfelt, P. Hallbjorner, H. Zirath, and A. Alping, "High gain active microstrip antenna for 60-GHz WLAN/WPAN applications," *IEEE Trans. Microw. Theory Techn.*, vol. 54, no. 6, pp. 2593–2603, Jun. 2006.
- [131] A. E. I. Lamminen, J. Saily, and A. R. Vimpri, "60-GHz patch antennas and arrays on LTCC with embedded-cavity substrates," *IEEE Trans. Antennas Propag.*, vol. 56, no. 9, pp. 2865–2874, Sep. 2008.
- [132] Y. P. Zhang, M. Sun, K. M. Chua, L. L. Wai, and D. Liu, "Integration of slot antenna in LTCC package for 60 GHz radios," *Electron. Lett.*, vol. 44, no. 5, pp. 330–331, Feb. 2008.
- [133] Y. P. Zhang, M. Sun, K. M. Chua, L. L. Wai, and D. Liu, "Antenna-in-package design for wirebond interconnection to highly integrated 60-GHz radios," *IEEE Trans. Antennas Propag.*, vol. 57, no. 10, pp. 2842–2852, Oct. 2009.
- [134] D. Liu, J. A. Akkermans, H.-C. Chen, and B. Floyd, "Packages with integrated 60-GHz aperture-coupled patch antennas," *IEEE Trans. Antennas Propag.*, vol. 59, no. 10, pp. 3607–3616, Oct. 2011.
- [135] T. S. Rappaport, F. Gutierrez, Jr, and T. Al-Attar, "Millimeter-wave and terahertz wireless RFIC and on-chip antenna design: Tools and layout techniques," in *Proc. IEEE Globecom Workshops*, Dec. 2009, pp. 1–7.
- [136] B. Pan, Y. Li, G. E. Ponchak, J. Papapolymerou, and M. M. Tentzeris, "A 60-GHz CPW-fed high-gain and broadband integrated horn antenna," *IEEE Trans. Antennas Propag.*, vol. 57, no. 4, pp. 1050–1056, Apr. 2009.
- [137] W. Hong, K. H. Baek, and A. Goudelev, "Grid assembly-free 60-GHz antenna module embedded in fr-4 transceiver carrier board," *IEEE Trans. Antennas Propag.*, vol. 61, no. 4, pp. 1573–1580, Apr. 2013.
- [138] P. Roy, R. K. Vishwakarma, A. Jain, and R. Singh, "Multiband millimeter wave antenna array for 5G communication," in *Proc. Int. Conf. Emerg. Trends Elect. Electron. Sustain. Energy Syst. (ICETESES)*, Mar. 2016, pp. 102–105.
- [139] W. Hong, K.-H. Baek, and S. Ko, "Millimeter-wave 5G antennas for smartphones: Overview and experimental demonstration," *IEEE Trans. Antennas Propag.*, vol. 65, no. 12, pp. 6250–6261, Dec. 2017.
- [140] M. S. Alam, M. T. Islam, N. Misran, and J. S. Mandeep, "A wideband microstrip patch antenna for 60 GHz wireless applications," *Elektronika ir Elektrotechnika*, vol. 19, no. 9, pp. 65–70, Jan. 2013.
- [141] L. Desclos, "V-Band double-slot antenna integration on LTCC substrate using thick-film technology," *Microw. Opt. Technol. Lett.*, vol. 28, no. 5, pp. 354–357, Mar. 2001.
- [142] J.-H. Lee, N. Kidera, S. Pinel, J. Laskar, and M. M. Tentzeris, "Fully integrated passive front-end solutions for a V-band LTCC wireless system," *IEEE Antennas Wireless Propag. Lett.*, vol. 6, pp. 285–288, 2007.
- [143] D. Schaubert, E. Kollberg, T. Korzeniowski, T. Thungren, J. Johansson, and K. S. Yngvesson, "Endfire tapered slot antennas on dielectric substrates," *IEEE Trans. Antennas Propag.*, vol. AP-33, no. 12, pp. 1392–1400, Dec. 1985.
- [144] G. M. Rebeiz, D. P. Kasilingam, Y. Guo, P. A. Stimson, and D. B. Rutledge, "Monolithic millimeter-wave two-dimensional horn imaging arrays," *IEEE Trans. Antennas Propag.*, vol. 38, no. 9, pp. 1473–1482, Sep. 1990.
- [145] Y. J. Cheng, W. Hong, and K. Wu, "94 GHz substrate integrated monopulse antenna array," *IEEE Trans. Antennas Propag.*, vol. 60, no. 1, pp. 121–129, Jan. 2012.
- [146] Y. Li and K.-M. Luk, "A multibeam end-fire magnetoelectric dipole antenna array for millimeter-wave applications," *IEEE Trans. Antennas Propag.*, vol. 64, no. 7, pp. 2894–2904, Jul. 2016.
- [147] J. Choi, V. Va, N. G.-Prelicic, R. Daniels, C. R. Bhat, and R. W. Heath, "Millimeter-wave vehicular communication to support massive automotive sensing," *IEEE Commun. Mag.*, vol. 54, no. 12, pp. 160–167, Dec. 2016.
- [148] M. Li, P. Schmalenberg, and J. S. Lee, "Millimeter-wave tapered slot array for automotive radar applications," in *Proc. Int. Symp. Antennas Propag. (ISAP)*, Oct. 2016, pp. 702–703.

- [149] F. Gutierrez, Jr, T. S. Rappaport, and J. Murdock, "Millimeter-wave CMOS antennas and RFIC parameter extraction for vehicular applications," in *Proc. IEEE 72nd Veh. Technol. Conf. Fall*, Sep. 2010, pp. 1–6.
- [150] P. Gardner, P. S. Hall, E. Lee, T. Y. Lee, and R. Foster, "Millimetre wave antennas using microstrip and air spaced suspended line techniques for vehicular communications and radar," in *Proc. 1st Eur. Conf. Antennas Propag.*, Nov. 2006, pp. 1–5.
- [151] H. S. Lee, J.-G. Kim, S. Hong, and J.-B. Yoon, "Micromachined CPW-fed suspended patch antenna for 77 GHz automotive radar applications," in *Proc. Eur. Conf. Wireless Technol.*, Oct. 2005, pp. 249–252.
- [152] J. Hatch, A. Topak, R. Schnabel, T. Zwick, R. Weigel, and C. Waldschmidt, "Millimeter-wave technology for automotive radar sensors in the 77 GHz frequency band," *IEEE Trans. Microw. Theory Techn.*, vol. 60, no. 3, pp. 845–860, Mar. 2012.
- [153] N. Shino, H. Uchimura, and K. Miyazato, "77GHz band antenna array substrate for short range car radar," in *IEEE MTT-S Int. Microw. Symp. Dig.*, Jun. 2005, p. 4.
- [154] F. Topfer and J. Oberhammer, "Millimeter-wave tissue diagnosis: The most promising fields for medical applications," *IEEE Microw. Mag.*, vol. 16, no. 4, pp. 97–113, May 2015.
- [155] A. Mirbeik, V. Tavassoli, F. Ayazi, and N. Tavassolian, "Three-dimensional super-wideband micro-antenna for high-resolution millimeter-wave medical imaging," in *Proc. 36th Annu. Int. Conf. IEEE Eng. Med. Biol. Soc.*, Aug. 2014, pp. 4999–5002.
- [156] S. Kharkovsky, M. T. Ghasr, M. A. Abou-Khousa, and R. Zoughi, "Near-field microwave and mm-wave noninvasive diagnosis of human skin," in *Proc. IEEE Int. Workshop Med. Meas. Appl.*, May 2009, pp. 5–7.
- [157] N. Klein, P. Lahl, U. Poppe, F. Kadlec, and P. Kužel, "A metal-dielectric antenna for terahertz near-field imaging," *J. Appl. Phys.*, vol. 98, no. 1, pp. 014910-1–014910-5, 2005.
- [158] D. Caratelli, A. Massaro, R. Cingolani, and A. G. Yarovoy, "Accurate time-domain modeling of reconfigurable antenna sensors for non-invasive melanoma skin cancer detection," *IEEE Sensors J.*, vol. 12, no. 3, pp. 635–643, Mar. 2012.
- [159] M. Hofmann, G. Fischer, R. Weigel, and D. Kissinger, "Microwave-based noninvasive concentration measurements for biomedical applications," *IEEE Trans. Microw. Theory Techn.*, vol. 61, no. 5, pp. 2195–2204, May 2013.
- [160] T. Takeyama and Y. Nikawa, "Change of electromagnetic field distribution in millimeter waves by dental caries appearance," in *Proc. Asia-Pacific Microw. Conf.*, Dec. 2010, pp. 1372–1375.
- [161] Y. Nikawa, N. Hoshi, K. Kawai, and S. Ebisu, "Study on dental diagnosis and treatment using millimeter waves," *IEEE Trans. Microw. Theory Techn.*, vol. 48, no. 11, pp. 1783–1788, Nov. 2000.
- [162] C. M. Alabaster, "Permittivity of human skin in millimetre wave band," *Electron. Lett.*, vol. 39, no. 21, pp. 1521–1522, Oct. 2003.
- [163] A. Taeb, S. Gigoyan, and S. Safavi-Naeini, "Millimetre-wave waveguide reflectometers for early detection of skin cancer," *IET Microw., Antennas Propag.*, vol. 7, no. 14, pp. 1182–1186, Nov. 2013.
- [164] Y. Gao and R. Zoughi, "Millimeter wave reflectometry and imaging for noninvasive diagnosis of skin burn injuries," *IEEE Trans. Instrum. Meas.*, vol. 66, no. 1, pp. 77–84, Jan. 2017.
- [165] J.-M. Kim, D. H. Oh, C. W. Baek, J. W. Cho, Y. Kwon, C. Cheon, and Y. K. Kim, "In vitro measurement using a MEMS probe array with five-strip lines for permittivity measurement," *J. Micromech. Microeng.*, vol. 16, no. 1, p. 173, Dec. 2005.
- [166] J.-M. Kim, C. Cheon, Y. Kwon, and Y.-K. Kim, "A hybrid RF MEMS probe array system with a SP3T RF MEMS silicon switch for permittivity measurement," *J. Micromech. Microeng.*, vol. 18, no. 8, 2008, Art. no. 085006.
- [167] S. Ullah, S. Ullah, and S. Khan, "Design and analysis of a 60 GHz millimeter wave antenna," *Jurnal Teknologi*, vol. 78, nos. 3–4, pp. 63–68, Apr. 2016.
- [168] E. Kasper and W. Zhang, "SIMMWIC integration of millimeter-wave antenna with two terminal devices for medical applications," in *Proc. IEEE 15th Top. Meeting Silicon Monolithic Integr. Circuits RF Syst.*, Jan. 2015, pp. 1–3.
- [169] F. Töpfer, L. Emtestam, and J. Oberhammer, "Dermatological verification of micro-machined millimeter-wave skin-cancer probe," in *Proc. IEEE MTT-S Int. Microw. Symp.*, Jun. 2014, pp. 1–4.
- [170] T. Yilmaz, G. Gokkoca, and O. B. Akan, "Millimetre wave communication for 5G IoT applications," in *Internet Things (IoT) 5G Mobile Technologies*. New York, NY, USA: Springer, 2016, pp. 37–53.
- [171] K. Takahashi, H. Yomo, T. Matsuoka, J. Sato, Y. Nakagawa, M. Yasugi, M. Irie, N. Shirakata, and K. Takinami, "Evolution of millimeter-wave multi-antenna systems in the IoT era," *IEICE Trans. Electron.*, vol. 100, no. 10, pp. 809–817, Oct. 2017.
- [172] J. Sato, K. Takinami, and K. Takahashi, "Millimeter wave CMOS integrated circuit for multi-gigabit communication and radar applications," in *Proc. IEEE Int. Symp. Radio-Freq. Integr. Technol. (RFIT)*, Aug. 2015, pp. 49–51.
- [173] P. F. Freidl, M. E. Gadringer, D. Amschl, and W. Bösch, "mm-Wave RFID for IoT applications," in *Proc. Integr. Nonlinear Microw. Millimetre-Wave Circuits Workshop (INMMiC)*, Apr. 2017, pp. 1–3.
- [174] J. Kimionis, A. Georgiadis, and M. M. Tentzeris, "Millimeter-wave backscatter: A quantum leap for gigabit communication, RF sensing, and wearables," in *Proc. IEEE MTT-S Int. Microw. Symp. (IMS)*, Jun. 2017, pp. 812–815.
- [175] A. Chockalingam and B. S. Rajan, *Large MIMO systems*. Cambridge, U.K.: Cambridge Univ. Press, 2014.
- [176] A. L. Swindlehurst, E. Ayanoglu, P. Heydari, and F. Capolino, "Millimeter-wave massive MIMO: The next wireless revolution?" *IEEE Commun. Mag.*, vol. 52, no. 9, pp. 56–62, Sep. 2014.
- [177] J. Brady, N. Behdad, and A. M. Sayeed, "Beamspace MIMO for millimeter-wave communications: System architecture, modeling, analysis, and measurements," *IEEE Trans. Antennas Propag.*, vol. 61, no. 7, pp. 3814–3827, Jul. 2013.
- [178] F. Tzeng, A. Jahanian, D. Pi, and P. Heydari, "A CMOS code-modulated path-sharing multi-antenna receiver front-end," *IEEE J. Solid-State Circuits*, vol. 44, no. 5, pp. 1321–1335, May 2009.
- [179] A. Jahanian, F. Tzeng, and P. Heydari, "Code-modulated path-sharing multi-antenna receivers: Theory and analysis," *IEEE Trans. Wireless Commun.*, vol. 8, no. 5, pp. 2193–2201, May 2009.
- [180] A. Kalis, A. G. Kanatas, and C. B. Papadias, *Parasitic Antenna Arrays for Wireless MIMO Systems*. New York, NY, USA: Springer, 2014.
- [181] M. M. M. Ali and A.-R. Sebak, "Design of compact millimeter wave massive MIMO dual-band (28/38 GHz) antenna array for future 5G communication systems," in *Proc. 17th Int. Symp. Antenna Technol. Appl. Electromagn. (ANTEM)*, Jul. 2016, pp. 1–2.
- [182] W. Tan, S. D. Assimonis, M. Matthaiou, Y. Han, X. Li, and S. Jin, "Analysis of different planar antenna arrays for mmWave massive MIMO systems," in *Proc. IEEE 85th Veh. Technol. Conf. (VTC Spring)*, Jun. 2017, pp. 1–5.
- [183] D.-W. Yue, S. Xu, and H. H. Nguyen, "Diversity gain of millimeter-wave massive MIMO systems with distributed antenna arrays," *J. Wireless Commun. Netw.*, vol. 2019, no. 1, p. 54, 2019.
- [184] N. Tawa, T. Kuwabara, Y. Maruta, M. Tanio, and T. Kaneko, "28 GHz downlink multi-user MIMO experimental verification using 360 element digital AAs for 5G massive MIMO," in *Proc. 48th Eur. Microw. Conf. (EuMC)*, Aug. 2018, pp. 934–937.
- [185] E. Björnson, L. Sanguinetti, H. Wymeersch, J. Hoydis, and T. L. Marzetta, "Massive MIMO is a reality—what is next? five promising research directions for antenna arrays," 2019, *arXiv:1902.07678*. [Online]. Available: <https://arxiv.org/abs/1902.07678>
- [186] S. Rangan, T. S. Rappaport, and E. Erkip, "Millimeter-wave cellular wireless networks: Potentials and challenges," *Proc. IEEE*, vol. 102, no. 3, pp. 366–385, Mar. 2014.
- [187] B. C. Pan, W. X. Tang, M. Q. Qi, H. F. Ma, Z. Tao, and T. J. Cui, "Reduction of the spatially mutual coupling between dual-polarized patch antennas using coupled metamaterial slabs," *Sci. Rep.*, vol. 6, Jul. 2016, Art. no. 30288.
- [188] K. Sarabandi, A. Jam, M. Vahidpour, and J. East, "A novel frequency beam-steering antenna array for submillimeter-wave applications," *IEEE Trans. Terahertz Sci. Technol.*, vol. 8, no. 6, pp. 654–665, Nov. 2018.
- [189] B. Schoenlinner, X. Wu, J. P. Ebling, G. V. Eleftheriades, and G. M. Rebeiz, "Wide-scan spherical-lens antennas for automotive radars," *IEEE Trans. Microw. Theory Techn.*, vol. 50, no. 9, pp. 2166–2175, Sep. 2002.
- [190] M. Xiao, S. Mumtaz, Y. Huang, L. Dai, Y. Li, M. Matthaiou, G. K. Karagiannidis, E. Björnson, K. Yang, C.-L. I, and A. Ghosh, "Millimeter wave communications for future mobile networks," *IEEE J. Sel. Areas Commun.*, vol. 35, no. 9, pp. 1909–1935, Sep. 2017.
- [191] R. W. Heath, N. González-Prelcic, S. Rangan, W. Roh, and A. M. Sayeed, "An overview of signal processing techniques for millimeter wave MIMO systems," *IEEE J. Sel. Topics Signal Process.*, vol. 10, no. 3, pp. 436–453, Apr. 2016.

- [192] X. Gao, L. Dai, and A. M. Sayeed, "Low RF-complexity technologies to enable millimeter-wave MIMO with large antenna array for 5G wireless communications," *IEEE Commun. Mag.*, vol. 56, no. 4, pp. 211–217, Apr. 2018.
- [193] Z. Zhang, K. C. Teh, and K. H. Li, "Study of three-dimensional Beamforming strategies in cellular networks with clustered user distribution," *IEEE Trans. Veh. Technol.*, vol. 65, no. 12, pp. 10208–10213, Dec. 2016.
- [194] J. Jang, M. Chung, S. C. Hwang, Y.-G. Lim, H.-J. Yoon, T. Oh, B.-W. Min, Y. Lee, K. S. Kim, C.-B. Chae, and D. K. Kim, "Smart small cell with hybrid beamforming for 5G: Theoretical feasibility and prototype results," *IEEE Wireless Commun.*, vol. 23, no. 6, pp. 124–131, Dec. 2016.
- [195] S. M. Razavizadeh, M. Ahn, and I. Lee, "Three-dimensional beamforming: A new enabling technology for 5G wireless networks," *IEEE Signal Process. Mag.*, vol. 31, no. 6, pp. 94–101, Nov. 2014.
- [196] Y.-H. Nam, B. L. Ng, K. Sayana, Y. Li, J. Zhang, Y. Kim, and J. Lee, "Full-dimension MIMO (FD-MIMO) for next generation cellular technology," *IEEE Commun. Mag.*, vol. 51, no. 6, pp. 172–179, Jun. 2013.
- [197] Y. Li, K. C. Ho, and C. Kwan, "3-D array pattern synthesis with frequency invariant property for concentric ring array," *IEEE Trans. Signal Process.*, vol. 54, no. 2, pp. 780–784, Feb. 2006.



SASWATI GHOSH received the Ph.D. degree from IIT Kharagpur, India, where she is currently a Postdoctoral Research Fellow with G. S. Sanyal School of Telecommunications. She is involved in active research in the area of antenna design for 60-GHz communication, RF energy harvesting, EMI/EMC measurements and EMI sensors, estimation of EMC of high-frequency electronic systems, and EMI/EMC/ESD on spacecraft bodies. She has 15 international journal publications, three book chapters, and more than 60 publications, including national journals and national/international conference proceedings. She serves as a Reviewer for several international journals. She had received the Young Scientist Fellowship twice and the Women Scientist Fellowship from the Department of Science and Technology, Government of India.



DEBARATI SEN received the Ph.D. degree in telecommunication engineering from IIT Kharagpur, Kharagpur, India, where she is currently an Assistant Professor. Her research interests include wireless and optical communication systems, mostly on MB-OFDM, synchronization, equalization, UWB, BAN, green communications, 60-GHz communications, and baseband algorithm design for coherent optical communications. She was a Postdoctoral Research Fellow with the Chalmers University of Technology, Sweden, and a Senior Chief Engineer with Samsung Research and Development Institute India, Bengaluru (SRI-B), India. She is an Editorial Board Member of two international journals. She was a recipient of the Best Paper Award at Samsung Tech. Conference 2010 and the IET Young Engineers Award, in 2010.

...