



Aalborg Universitet

AALBORG UNIVERSITY
DENMARK

An MPC Based ESS Control Method for PV Power Smoothing Applications

Lei, Mingyu; Yang, Zilong; Wang, Yibo; Xu, Honghua; Meng, Lexuan; Quintero, Juan Carlos Vasquez; Guerrero, Josep M.

Published in:
I E E E Transactions on Power Electronics

DOI (link to publication from Publisher):
[10.1109/TPEL.2017.2694448](https://doi.org/10.1109/TPEL.2017.2694448)

Publication date:
2018

Document Version
Early version, also known as pre-print

[Link to publication from Aalborg University](#)

Citation for published version (APA):
Lei, M., Yang, Z., Wang, Y., Xu, H., Meng, L., Quintero, J. C. V., & Guerrero, J. M. (2018). An MPC Based ESS Control Method for PV Power Smoothing Applications. *I E E E Transactions on Power Electronics*, *33*(3), 2136 - 2144 . [7900331]. <https://doi.org/10.1109/TPEL.2017.2694448>

General rights

Copyright and moral rights for the publications made accessible in the public portal are retained by the authors and/or other copyright owners and it is a condition of accessing publications that users recognise and abide by the legal requirements associated with these rights.

- Users may download and print one copy of any publication from the public portal for the purpose of private study or research.
- You may not further distribute the material or use it for any profit-making activity or commercial gain
- You may freely distribute the URL identifying the publication in the public portal -

Take down policy

If you believe that this document breaches copyright please contact us at vbn@aub.aau.dk providing details, and we will remove access to the work immediately and investigate your claim.

A MPC Based ESS Control Method for PV Power Smoothing Applications

Mingyu Lei, *Student Member, IEEE*, Zilong Yang, Yibo Wang, Honghua Xu, Lexuan Meng, *Member, IEEE*, Juan C. Vasquez, *Senior Member, IEEE*, Josep M. Guerrero, *Fellow, IEEE*

Abstract-Random fluctuation in photovoltaic (PV) power plants is becoming a serious problem affecting the power quality and stability of the grid along with the increasing penetration of PVs. In order to solve this problem, by the adding of energy storage systems (ESS), a grid-connected microgrid system can be performed. To make this system feasible, this paper proposes a model predictive control (MPC) based on power/voltage smoothing strategy. With the receding horizon optimization performed by MPC, the system parameters can be estimated with high accuracy, and at the same time the optimal ESS power reference is obtained. The critical parameters, such as state of charge (SoC), are also taken into account in order to ensure the health and stability of the ESSs. In this proposed control strategy, communication between PVs and ESS is not needed, since control command can be calculated with local measured data. At the same time, MPC can make a great contribution to the accuracy and timeliness of the control. Finally, experimental results from a grid-connected lab-scale microgrid system are presented to prove effectiveness and robustness of the proposed approach.

Index Terms-Energy storage, photovoltaic, power quality, model predictive control (MPC), power smoothing

I. INTRODUCTION

During recent years, the number of grid-connected PV systems is considerably increased around the world aiming at establishing a sustainable energy system [1]-[3]. While in the other hand, the stochastic fluctuating of PV power is becoming a significant issue affecting the power quality and stability of the grid [4]. As the maximum power point tracking (MPPT) control is used in most of the PV systems, the output power necessarily varies with the change of illumination intensity and

some other environmental factors [5]. In addition, the control of the PV system and the electrical parameters may also result in the output power variations [6]. One of the major concerns about PV power fluctuation is that it may lead to voltage deviation exceeding related limits, for example, $\pm 5\%$ of nominal voltage as given by service voltage limits of IEEE Std 1547a-2014 [7]. This problem would be more serious when PVs are connected in remote area where the grid is weak, or in small scale low voltage distribution network, the capacity of which is relatively small.

In this sense, energy storage systems (ESSs), being proved in many research works and applications, can be an effective solution to smooth fluctuation and to improve the stability of the power grid [8]-[14]. Obviously, the control strategy of ESS is one of the most important aspects to be considered. In [12] a power management method for a combined PV-ESS system was proposed, which keeps power balance within a microgrid and maintains the state of health (SoH) of the ESS. The authors of [13] propose a novel control strategy for smoothing the output power fluctuation of renewable energy generation system, consisting of SoC feedback control and the real-time power allocation method. This strategy can keep SoC within a specified range and make sure that the ESS units share the load consistently. A ramp limiting based battery ESS control strategy is proposed in [14] to smooth the PV power fluctuation. By using this strategy, the size of the ESS can be effectively reduced and the performance is also improved.

However, by using the aforementioned conventional control methods, communication between ESS and PV is necessary, which leads to system complexity and possibility of failures due to packet losses and latencies. At the same time, conventional methods usually use the data of past sampling periods, resulting in delays in the ESS actions. These delays may lead to decrease of efficiency and waste of ESS energy.

To enhance the performance of power smoothing control and to avoid the communication dependency, this paper proposes a model predictive control (MPC) strategy for PV-ESS integrated system. MPC algorithms have been widely used in process control from last century, recently they are also applied to control of power converters and some switching power supplies [15]-[18]. This paper finds its novel application in energy management of renewable energy systems with ESS units. Satisfying results are obtained because of the notable advantage of MPC: MPC can make a great contribution to the

Mingyu Lei is with 1) University of Chinese Academy of Sciences 2) Solar Thermal Technology and Photovoltaic System Laboratory, China Academy of Sciences. 3) Institute of Electrical Engineering, Chinese Academy of Sciences, Beijing 100190, China (email: leimingyu@mail.iee.ac.cn).

Zilong Yang, Yibo Wang, Honghua Xu are with 1) Solar Thermal Technology and Photovoltaic System Laboratory, China Academy of Sciences. 2) Institute of Electrical Engineering, Chinese Academy of Sciences, Beijing 100190, China (email: yangzl@mail.iee.ac.cn, wyb@mail.iee.ac.cn, hxu@mail.iee.ac.cn).

L. Meng, J. C. Vasquez, J. M. Guerrero are with Department of Energy Technology, Aalborg University, 9220 Aalborg, Denmark (e-mail: lme@et.aau.dk; juq@et.aau.dk; joz@et.aau.dk).

This paper was supported by The National High Technology Research and Development of China 863 Program (2015AA050101)

accuracy and timeliness of the control system since it has the ability to predict the future change of the control objective [19]. At the same time, inputs and outputs constraints can be handled in the MPC to ensure the security of the hybrid system.

The objective of the proposal is to maintain the power grid voltage stability and reduce voltage fluctuation when the PV system is working at MPPT. In this paper, the value predicted in MPC is the equivalent input impedance of ESS. It can be obtained the relatively accurate predictive value by a receding horizon optimization, and the real value of this parameter will not change over time. Using the predicted input impedance, control command of ESS can be calculated. Another advantage of this proposed control is that communication between PV and ESS is not needed as the control command can be obtained with local measured data. As a result, the stability of the control is improved and the cost is reduced.

II. ENERGY STORAGE CONTROL OBJECTIVES

Stochastic change of weather and environment is the main cause of fluctuation of PV output power [20], [21]. The fluctuation may seriously affect the power quality of grid when natural factors are changing sharply [22], [23]. Fig.1 shows a 30-days output power curve of a 100kWp PV system, which is built in Jiaxing, a city of Zhejiang Province, China [24]. To analyze its characteristics, the maximum power change with 10-minute resolution is extracted as shown in Fig.2. It can be seen that the maximum value of 10-minute largest power change is 59.5kW, accounting for nearly 60% of the maximum power of the PV system. In this situation, the voltage change would be great, especially when the rated power of a PV system is larger or it is connected into the low voltage networks. This paper addresses the power quality problem caused by PV power fluctuation. To analyze the effect on voltage by PV power fluctuation, a simulation is conducted by using this power curve to emulate a PV system which is connected to a 380V AC grid with a 0.2Ωline resistance and 0.3mH inductance. Fig.3 shows the RMS voltage value of one phase at the point of common coupling (PCC) during this period of time. It can be observed that the maximum deviation is larger than 10% rated voltage, which would affect the stability and safety of the grid.

To solve this problem, large-capacity ESS can be implemented to smooth the power and improve the power quality. In this hybrid system, battery is chosen as the ESS technology, as it presents following features: 1) the stability and safety must be guaranteed and they can work well without frequent maintenance [25]; 2) the cost of the energy storage system has to be considered, since the storage capacity is rather large to ensure long-term charging or discharging; 3) easy implementation is required because many distributed generation systems are located in remote areas [26].

The combined PV-ESS system is shown in Fig.4. This system consists of PV generator, battery ESS, local load and grid. The PV and ESSs are two separated systems and there is no communication between them. The hybrid system is regarded as a generating unit connected to the grid, and its total output power is expected to be smooth. By controlling the ESS

charging and discharging power, the effect of PV power fluctuation can be reduced and the power quality at the PCC will be improved.

In this system, ESSs are connected to the AC bus together with the PV. A remarkable advantage of this structure is that it is not necessary to redesign and replace the PV inverters and transformers when implementing ESSs. The online plug-and-play ESS units can be realized without affecting the PV generation. Accordingly the maintenance of PV-ESS system becomes more convenient, the flexibility and safety of the system is improved as well.

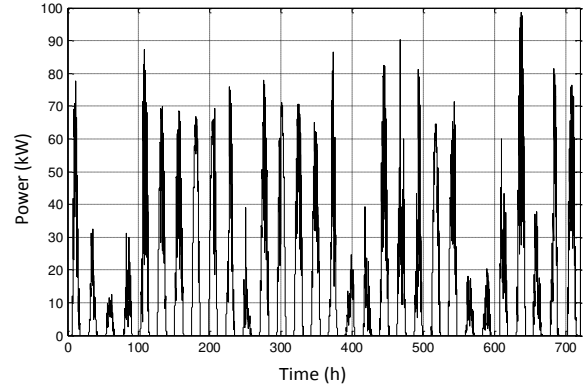

Fig.1 30-days output power curve of a 100kWp PV system

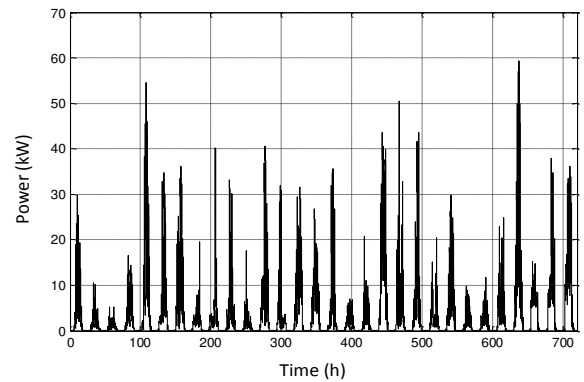

Fig.2 10-minute largest change curve of 30-days PV power

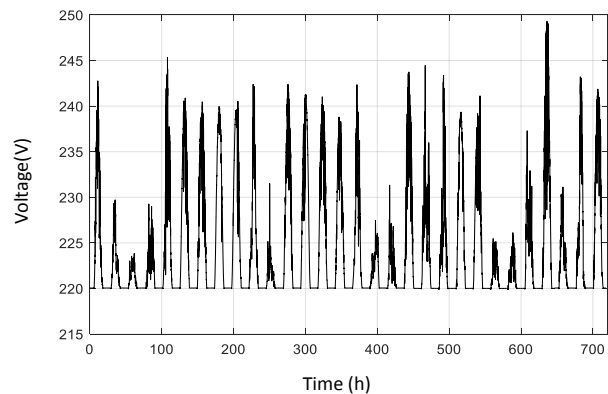

Fig.3 30-days PCC voltage curve of a PV system

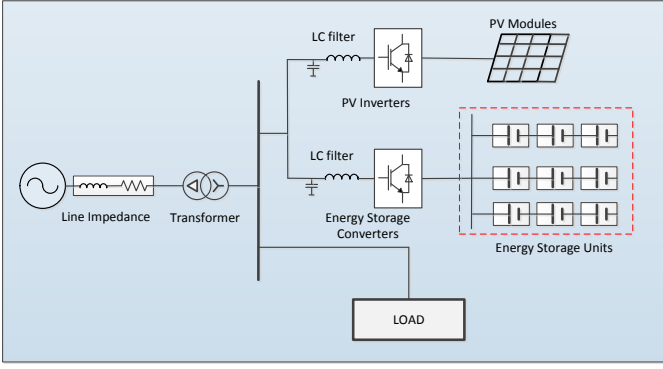

Fig.4 Combined PV-ESS system

III. VOLTAGE DEVIATION CAUSED BY PV POWER

When a grid-connected PV system is working at the MPPT mode without ESS, the output power will cause oscillation of PCC voltage. Supposing that the equivalent impedance between the PV and the grid is $R+jX$, the voltage deviation can be expressed as:

$$\begin{aligned} \square \dot{v} &= \frac{p_{pv}R + q_{pv}X}{v} \\ \delta \dot{v} &= \frac{p_{pv}X - q_{pv}R}{v} \end{aligned} \quad (1)$$

where p_{pv} is the active power, q_{pv} is the reactive power and v is the PCC voltage of the PV system. $\square \dot{v}$ is the horizontal voltage deviation which is parallel to the grid voltage, and $\delta \dot{v}$ is the vertical voltage deviation which is perpendicular to the grid voltage. The expression between voltage deviation and $\square \dot{v}$ and $\delta \dot{v}$ is

$$|v_{grid} - v_{PCC}| = \sqrt{(\Delta v)^2 + (\delta v)^2} \quad (2)$$

The relation between grid voltage, PCC voltage and voltage deviation vectors is shown in Fig.5.

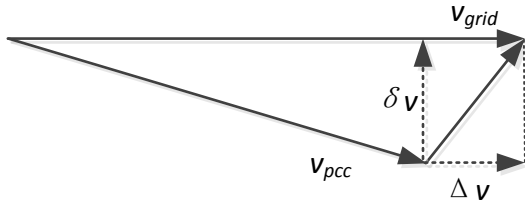

Fig.5 The relation between grid voltage, PCC voltage and voltage deviation

In a PV system, the reactive power can be ignored as it is much smaller than active power. So the above expression can be simplified as

$$\square \dot{v} = \frac{p_{pv}R}{v} \quad (3)$$

$$\delta \dot{v} = \frac{p_{pv}X}{v} \quad (4)$$

The magnitude of PCC voltage can be described as

$$v = v_g + \sqrt{|\delta v|^2 + |\Delta v|^2} = v_g + \frac{p_{pv} \cdot \sqrt{R^2 + X^2}}{v} = v_g + \frac{p_{pv} \cdot Z}{v} \quad (5)$$

where v_g is the grid voltage, which is considered to be stable and will not change over time. At PCC where PV connects the grid, the voltage presents a weak feature because of the line impedance. By this formula, it can be seen that the magnitude of impedance Z is the only model parameter that needs to be predicted at every step. When an ESS operates in this PV system, the PCC voltage can be expressed as

$$v = v_g + \frac{p_{ESS} \cdot Z_{ESS}}{v} \quad (6)$$

where p_{ESS} is the active power of ESS. Z_{ESS} is the equivalent input impedance of ESS, including line impedance between grid and hybrid system, and impedance of PV and load. The simplified structure of the hybrid system is shown in Fig.6, in which the components are represented by the equivalent circuits. It can be observed that the equivalent input impedance of ESS is a combination of Z_G , Z_{PV} and Z_L , as well as its own line impedance Z_o . Thus the input impedance of the ESS can be expressed as:

$$Z_{ESS} = Z_o + Z_G \parallel Z_L \parallel Z_{PV} \quad (7)$$

In this system, the impedance value Z_o , Z_L , Z_G , Z_{PV} are determined by control mode of the converters [27], [28] and not measurable. In the proposed control method, Z_{ESS} can be estimated and corrected by receding horizon optimization. Since the controller operates in discrete time, the PCC voltage can be predicted as

$$v(k+1) = v_g + \frac{p_{ESS}(k+1) \cdot Z_{ESS}(k)}{v(k+1)} \approx v_g + \frac{p_{ESS}(k+1) \cdot Z_{ESS}(k)}{v(k)} \quad (8)$$

where $v(k)$ is the measured value of the voltage, and $Z_{ESS}(k)$ is the predicted value of magnitude of equivalent input impedance of ESS. Therefore the voltage difference between $v(k)$ and $v(k+1)$ can be calculated.

$$v(k+1) - v(k) = \frac{\Delta p_{ESS}(k+1) \cdot Z_{ESS}(k)}{v(k)} \quad (9)$$

The purpose of this proposed control is to reduce or eliminate the difference between the PV voltage and the reference voltage (v^*) by controlling the charging and discharging power of the ESS. So with this expression, the optimal ESS power command can be calculated to stabilize PCC voltage.

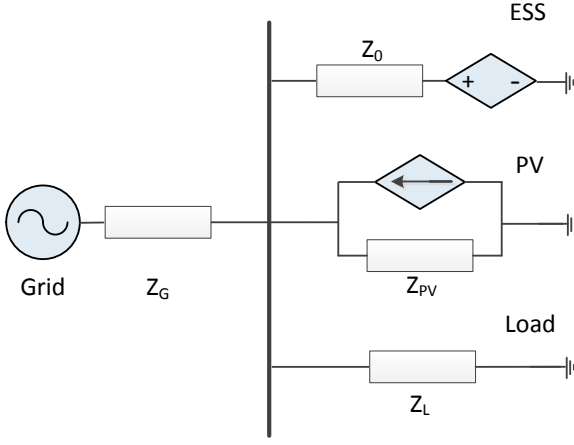

Fig.6 Simplified structure of ESS/PV hybrid system

IV. CONTROL STRATEGY FOR ENERGY STORAGE SYSTEM

In this paper, the specific process of MPC consists of three steps: predicting dynamic models of the controlled system, calculating control commands, and correcting dynamic models according to the measured data.

A. Predicting model parameter

In this control, the model parameter to be predicted is Z_{ESS} , which is the magnitude of equivalent input impedance of ESS. The optimal ESS output power at the next operation step, $p_{ESS}(k+1)$, can be calculated accordingly. At the beginning, an initial value of the impedance $Z_{ESS}(0)$ is randomly chosen. At the following steps, it is corrected according to the PCC voltage predicting error.

The control variable u and output variable Y are defined as follows:

$$u(k) = \Delta p_{ESS}(k) = p_{ESS}(k) - p_{ESS}(k-1) \quad (10)$$

$$Y(k) = v(k) \quad (11)$$

According to equations (9)-(11), the relationship between these two variables can be expressed as:

$$Y(k+1) = Y(k) + \frac{u(k+1)}{Y(k)} \cdot Z_{ESS}(k) \quad (12)$$

B. Calculating control command

In order to calculate $p_{ESS}(k+1)$, the cost function for the MPC needs to be formulated, which is actually to reduce the voltage deviation caused by PV power variation. In this case, the optimization cost function is

$$J = \min[w_1 (SoC - SoC^*)^2 + w_2 (v - v^*)^2] \quad (13)$$

where SoC is the state of charge of the ESS, the reference value of which is SoC^* , and v is the measured voltage value of PCC. The purpose of this control is to maintain a constant voltage value v^* . In industrial applications, the SoC of a group of batteries is defined by the lowest SoC value among all the batteries when discharging and by the highest SoC when charging. Although this method may cause a deviation of SoC calculating, it can prevent the over-discharging or over-charging situation and guarantee system security. The value of

v^* is decided by the grid nominal voltage, PV power and ESS capacity. w_1 and w_2 are the weight coefficients of these two parts of cost functions respectively, which are determined by the fluctuation characteristics of the PV power and the capacity of the ESS. If the capacity of the ESS is rather large or the fluctuation of the PV power is not dramatic, the value of w_2 can be increased to improve the smoothing effect. Otherwise, the value of w_1 should be increased to ensure the security and health of energy storage units. The SoC of ESS can be calculated as

$$SoC(k+1) = SoC(k) - \frac{p_{ESS}(k+1) \cdot T_s}{C_{ESS}} \quad (14)$$

Bringing (12) and (14) into (13), it can be obtained the equation about cost function $J(k+1)$ and control variable $u(k+1)$:

$$\begin{aligned} J(k+1) = & w_2 E_v^2(k) + \left(\frac{w_1 T_s^2}{C_{ESS}^2} + \frac{w_2 Z_{ESS}^2(k)}{v^2(k)} \right) u^2(k+1) \\ & + \left(\frac{2w_1 T_s^2 P_{ESS}(k)}{C_{ESS}^2} - \frac{2w_1 T_s E_{SOC}(k)}{C_{ESS}} + \frac{2w_2 Z_{ESS}(k) E_v(k)}{v(k)} \right) u(k+1) \\ & + w_1 (E_{SOC}^2(k) + \frac{T_s^2 P_{ESS}^2(k)}{C_{ESS}^2} - \frac{2T_s E_{SOC}(k) P_{ESS}(k)}{C_{ESS}}) \end{aligned} \quad (15)$$

where $Z_{ESS}(k)$ is the predicted magnitude of equivalent input impedance of ESS at last step, $v(k)$ is the measured voltage of PCC, and $P_{ESS}(k)$ is the power of ESS. E_{SOC} is the deviation of SoC and E_v is the deviation of voltage, and they are defined as (16) and (17) respectively:

$$E_{SOC}(k) = SoC(k) - SoC^* \quad (16)$$

$$E_v(k) = v(k) - v^* \quad (17)$$

From equation (15), it can be obtained the power change of ESS to minimize the value of cost function:

$$\begin{aligned} u(k+1) = & - \frac{w_1 T_s^2 P_{ESS}(k) v^2(k) - w_1 T_s E_{SOC}(k) C_{ESS} v^2(k) + w_2 E_v(k) Z(k) C_{ESS}^2 v(k)}{w_1 T_s^2 v^2(k) + w_2 Z^2(k) C_{ESS}^2} \end{aligned} \quad (18)$$

Since the control variable $u(k+1)$ is the change of ESS power, the power of next step can be obtained as:

$$p_{ESS}(k+1) = u(k+1) + p_{ESS}(k) \quad (19)$$

When $p_{ESS} > 0$, batteries are discharging, and when $p_{ESS} < 0$, they are charging. If the capacity of batteries is large enough or there is no need to consider the SoC of batteries, the coefficient $w_1 = 0$. In this condition, control variable $u(k+1)$ is expressed as:

$$u(k+1) = - \frac{(v(k) - v^*) v(k)}{Z_{ESS}(k)} \quad (20)$$

C. Correcting model parameters

In order to calculate the optimal power of the ESS, the control system must get the accurate model parameters. In this control method, an initial value of Z_{ESS} is provided at the

starting of the control. At every control step, the value of the model parameter will be corrected by the error of the predicted voltage. According to (9), the error of the predicted PV voltage can be described as

$$v(k+1) - v_r(k+1) = \frac{u(k+1)}{v(k)} [Z_{ESS}(k) - Z_{ESS_r}(k)] \quad (21)$$

where $v_r(k+1)$ is the real value of the PV voltage measured at step $(k+1)$. $Z_{ESS_r}(k)$ is the real value of the impedance. Therefore the relationship between the voltage predicting error and impedance correction can be described as

$$\begin{cases} Z_{ESS}(k) - Z_{ESS_r}(k) > 0 & \text{if } [v(k+1) - v_r(k+1)] / u(k+1) > 0 \\ Z_{ESS}(k) - Z_{ESS_r}(k) < 0 & \text{if } [v(k+1) - v_r(k+1)] / u(k+1) < 0 \end{cases} \quad (22)$$

At step k , the control command $u(k+1)$ and expected voltage $v(k+1)$ are calculated according to (12) and (18), using predicted magnitude of impedance $Z_{ESS}(k)$. During the next step, the PCC voltage is measured as $v_r(k+1)$, which is used to compare with $v(k+1)$ to correct $Z_{ESS}(k)$, according to (22). The correction expression of the predicted model parameter is as following:

$$\begin{cases} Z_{ESS}(k+1) = Z_{ESS}(k) - Z_0 & \text{if } [Z_{ESS}(k) - Z_{ESS_r}(k)] > 0 \\ Z_{ESS}(k+1) = Z_{ESS}(k) + Z_0 & \text{if } [Z_{ESS}(k) - Z_{ESS_r}(k)] < 0 \end{cases} \quad (23)$$

The correction of model parameters will stop when the error between the predicted voltage and the real voltage is small enough:

$$|v(k+1) - v_r(k+1)| \leq \xi \quad (24)$$

where ξ is the allowed maximum error of the predicted voltage (e.g. 0.5Vrms). In this expression, $v(k+1)$ is the expected voltage to minimize the optimization cost function J , which is obtained by (13). When the error between measured voltage $v_r(k+1)$ and expected voltage $v(k+1)$ is small enough, it means the control is accurate and satisfying model parameters of the hybrid system are obtained. The flow chart of this control strategy is shown in Fig.7.

D. Constraint of the control

In this proposed control method, the SoC of battery system is not only used to calculate the cost function, but also applied as a constraint of the control. When a group of batteries are implemented and operating together, the SoC of each battery cell has to be limited within a certain range, i.e. [0.2, 1]. In addition, the limitation of ESS power should also be taken into account. Take lead acid battery for example. To summarize, the constraint function of this control is given by:

$$P_{IN-MAX}^* < [P_{ESS}(k+1)] < P_{OUT-MAX}^* \quad (25)$$

$$0.2 \leq SoC(k) - \frac{p_{ESS}(k+1) \cdot T}{C_{ESS}} \leq 1 \quad (26)$$

where P_{IN-MAX} is the maximum charging power of ESS (<0), and $P_{OUT-MAX}$ is the maximum discharging power (>0).

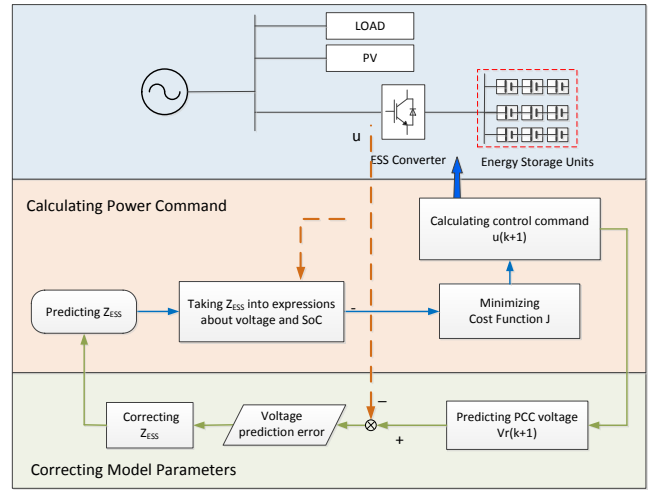

Fig.7 Flow chart of the proposed ESS control strategy

V. EXPERIMENTAL RESULT

In order to validate the effectiveness of the proposed control algorithm, experimental result is provided here. A MG setup, which consists of three Danfoss inverters, LC filters, line impedances and a real-time dSPACE1006 platform is established, as shown in Fig.8. Parameters of this lab-scale PV/ESS system are listed in Table.1 [29]. The power rating of each converter is 2.5kW. Two converters in this system works as PV inverters and the other one as an ESS converter, which is controlled by the proposed control strategy. During the experimental process, the PV inverters follow a power reference curve obtained from an industrial PV system, shown in Fig.1.

Fig.9 shows the power of the two PV converters, which is the same with each other, and the A-phase RMS voltage waveform when this system operates without ESS power. It can be seen the PCC voltage fluctuating with the PV power, and the maximum voltage change is 4.8V. In this experiment, PV power is limited by the converters, so the current injected into grid is not large enough to lead to violation of voltage limit [7]. But in PV system with high power ratings, the voltage fluctuation would be much more severe, and the impact on power quality and grid stability would be more serious.

TABLE I. THE PARAMETERS OF THE SIMULATION

Parameters	Symbol	Value	Unit
AC bus voltage (phase-to-phase)	V_{grid}	380	V
DC bus voltage	V_{DC}	650	V
Rated frequency	F	50	Hz
PV rated power	P_{pv}	4.4	kW
Capacity of ESS	C	10	kWh
ESS rated power	P_{bat}	2.5	kW
Line Resistance	R_{line}	2.1	Ω
Line Inductance	L_{line}	1.6	mH

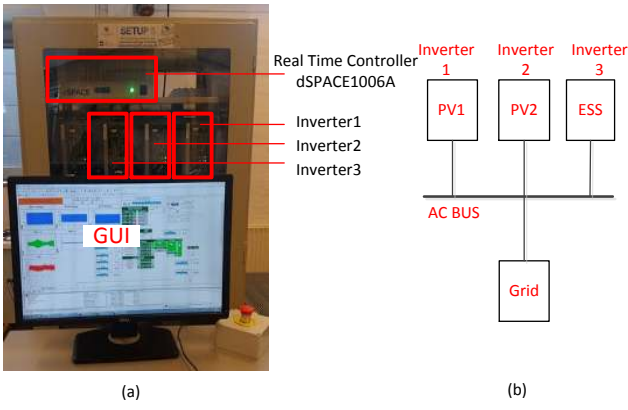

Fig.8 Experimental PV/ESS hybrid microgrid setup

The system performance with proposed control method is shown in Fig.10. The weight coefficients of cost functions w_1 and w_2 are set to 0.01 and 0.99 respectively. The SoC reference SoC^* is 0.75 and the initial value of SoC in the experiment is 0.85, which is enough to make sure the batteries healthy and guarantee full compensation of power oscillation when the PV power had a dramatic rise. The constant voltage reference is set as $v^*(i)=221V$, and there is no need to correct the predicted value of line impedance in the next step if the measured PCC voltage $220.7V < v(i) < 221.3V$.

It can be seen that ESS power is changing according to the PV power fluctuation. The PCC voltage fluctuation is smoothed effectively, and the maximum voltage change during this period is around 1.2V. Fig.10 (c) shows the curve of predicted magnitude of equivalent input impedance of ESS. It can be observed that the predicted impedance is varying during 0~100s, while it becomes constant after 100s indicating an accurate estimation. It means that the filtering result is better during 100~200s and the receding horizon control of MPC helps improving the accuracy of the control. Once the accurate model parameters are obtained, the control result will be stable and accurate. Moreover, the SoC curve of ESS is shown in Fig.10 (d). It can be observed that the change of SOC is very slow as the capacity is enough, and it will decrease when the PV power is very low at night or in bad weather.

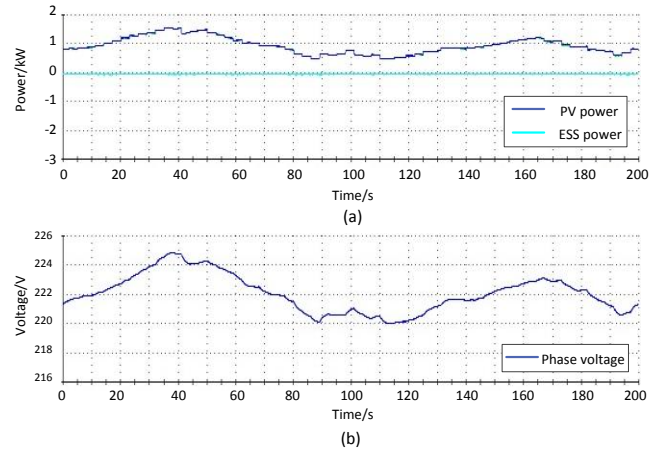

Fig.9 Waveforms of converters power and PCC voltage when ESS is not in operating (a) power of PV and ESS (b) phase RMS voltage of PCC

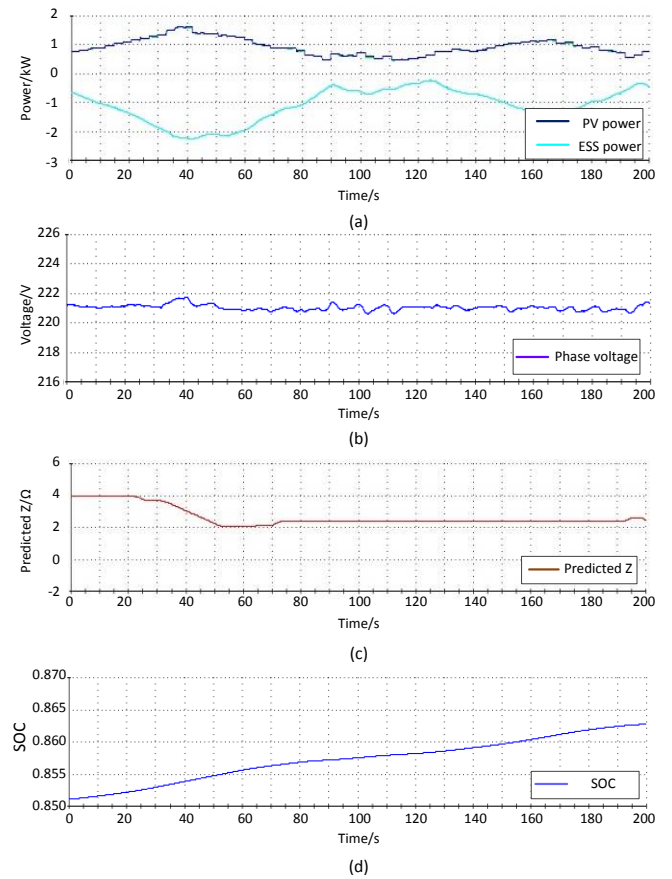

Fig.10 waveforms of converters power, PCC voltage, predicted impedance and SoC when ESS is controlled by proposed strategy. (a) power of PV and ESS (b) phase RMS voltage (c) predicted equivalent input impedance of ESS (d) SoC

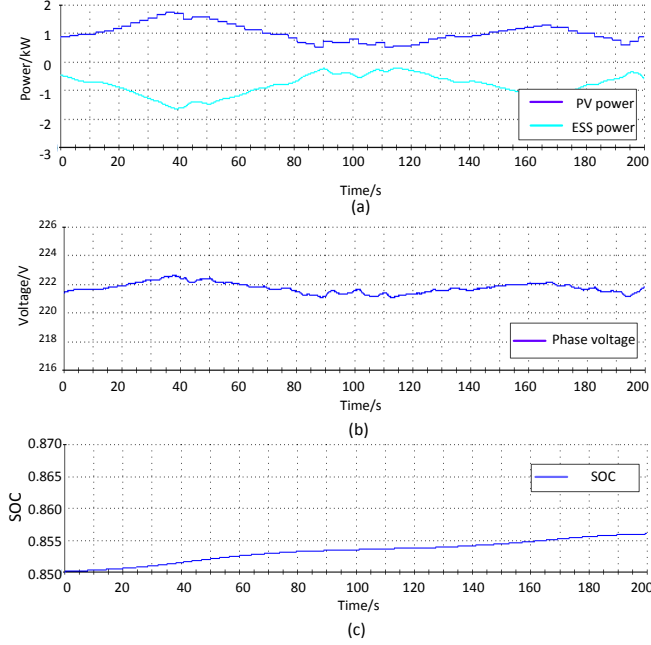

Fig.11 Waveforms of converters power, PCC voltage, and SoC when weight coefficients of SoC is increased. (a) power of PV and ESS (b) phase RMS voltage (c) SoC

In order to analyze the effect of weight coefficients w_1 and w_2 , another experiment is conducted, as shown in Fig.11, with $w_1=0.1$ and $w_2=0.9$, in order to compare with the results in Fig.10. It can be seen that the SoC is changing more slowly compared with Fig.10, resulting in a smaller deviation between ideal SoC and the real value. While on the other hand, the effect of smoothing control is weakened and the PCC voltage fluctuation is larger. In summary, the trade-off between smoothing result and the health of ESS can be well balanced by controlling the weight coefficients w_1 and w_2 . During the experiment, ESS continues charging energy since the PCC voltage keeps higher than the voltage reference. But in an actual PV system, when PV power is lower than local load power, or PV stops generating power at night, ESS would start discharging energy, leading to SoC reduction.

A number of experiments are carried out to validate the robustness of the proposed control strategy. The sudden disconnection of PV system is emulated in the experiment. In this case, the equivalent input impedance of ESS is changed, as it consists of PV inverters impedance (impedance of filters, transformers) and grid line impedance. The curves of ESS and PV power, PCC voltage and predicted input impedance of ESS are shown in Fig.12. It can be seen that there is a sudden change of the predicted value of equivalent input impedance when the loss of PV system occurs. But a new predicted value is obtained within 10s after the disconnection ensuring the stable operation of the system. During 150~200s, the maximum change of the voltage is within 0.7V. Fig.12 (b) shows the detailed actual phase current of ESS after the change of the hybrid system. It can be seen that ESS operating mode changes

from charging to discharging. This experiment proves that the proposed control strategy is considered highly robust even under fault conditions. The ESS starts to release power to the grid after PV has shut down, because at this time, SoC of ESS is higher than the SoC reference and the PCC voltage is not completely the same with the voltage reference. As a result, there is a decrease of the ESS SoC, as shown in Fig.12 (e).

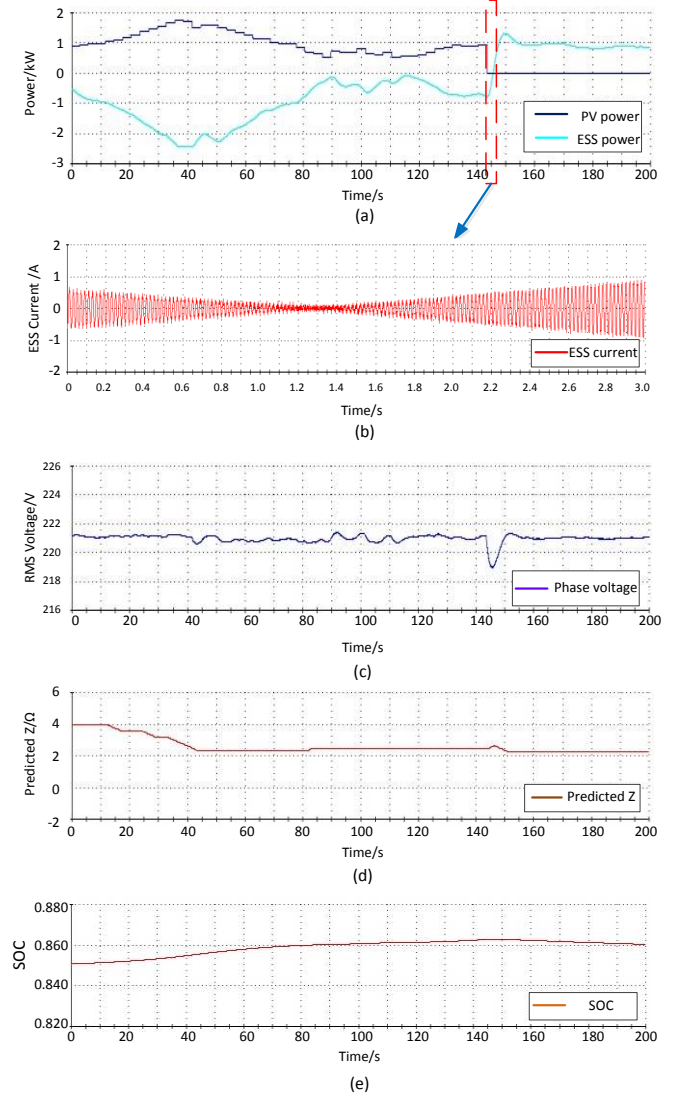

Fig.12 Waveforms of converters power, PCC voltage, and predicted impedance when ESS is controlled by proposed strategy and PV inverters are suddenly tripped. (a) power of PV and ESS (b) current of ESS in 2.5s when PV is tripped (c) phase RMS voltage (d) predicted equivalent input impedance of ESS (e) SoC

VI. CONCLUSION

In this paper, a novel ESS control strategy based on MPC is proposed, aiming to smooth the power fluctuation and to improve the power quality of a PV generation system. In this approach, no communication between PV and ESS is needed,

since control can be performed by using local measurements only. Furthermore, by receding horizon optimization, this control method can predict the model parameter more and more accurately, which is used to determine the ESS control command. When the accurate equivalent input impedance is obtained during the control process, the optimal control command can be given to ESS. Experimental results shows the effectiveness proposed control to improve the power quality of PV power plants, showing also good robustness when input impedance of ESS is changed

REFERENCE

[1] Josep M. Guerrero, Lijun Hang, Javier Uceda, "Control of Distributed Uninterruptible Power Supply Systems," IEEE Transactions on Industrial Electronics, vol. 55, no. 8, pp.2845-2859, 2008

[2] Jong-Yul Kim, Jin-Hong Jeon, Seul-Ki Kim, Changhee Cho and June Ho Park, "Cooperative Control Strategy of Energy Storage System and Microsources for Stabilizing the Microgrid during Islanded Operation". IEEE Transactions on Power Electronics, vol. 25, no. 12, Dec. 2010, pp.3037 - 3048

[3] W. Wang, L. Yan, X. Zeng, B. Fan, J. M. Guerrero, "Principle and Design of a Single-phase Inverter Based Grounding System for Neutral-to-ground Voltage Compensation in Distribution Networks", IEEE Transactions on Industrial Electronics, vol.64, no.2, pp.1204-1213, 2017

[4] M. H. Nehrir, C. Wang, K. Strunz, H. Aki, R. Ramakumar, J. Bing et al., "A review of hybrid renewable/alternative energy systems for electric power generation: Configurations, control, and applications," IEEE Trans on Sustain Energy, vol. 2, no. 4, pp. 392-403, Oct. 2011.

[5] M. Bragard, N. Soltan, S. Thomas, and R. W. De Doncker, "The balance of renewable sources and user demands in grids: Power electronics for modular battery energy storage systems," IEEE Trans. Power Electron., vol. 25, no. 12, pp. 3049-3056, Dec. 2010.

[6] Shuaixun Chen, Tian Zhang, H. B. Gooi, Ralph D. Masiello, and Warren Katzenstein, "Penetration Rate and Effectiveness Studies of Aggregated BESS for Frequency Regulation", vol.7, no.1, pp.167-177, 2016.

[7] IEEE Standard for Interconnecting Distributed Resources with Electric Power Systems—Amendment 1, IEEE Std 1547a-2014 (Amendment to IEEE Std 1547-2003), May 2014, pp. 1-16.

[8] Andrea Salimbeni; Mauro Boi; Ignazio Marongiu; Mario Porru;Alfonso Damiano, "Integration of active filter and energy storage system for power quality improvement in microgrids", International Symposium on Power Electronics, Electrical Drives, Automation and Motion, vol., no., pp.709 - 714, 2016.

[9] K.Li; H.Xu; Q.Ma and J.Zhao, "Hierarchy Control of Power Quality for Wind-Battery Energy Storage System", in IET Power Electronics, vol.7, no.8, pp.2123-2132, August 2014.

[10] Jianing Li; Zhi Wu; Suyang Zhou; Hao Fu; Xiao-Ping Zhang, CSEE Journal of Power and Energy Systems. "Integrated PV Capacity Firming and Energy Time Shift Battery Energy Storage Management Using Energy-Oriented Optimization", IEEE Transactions on Industry Applications, vol.52, no.3, pp.2607 - 2617 May-June 2016.

[11] Dimitrios Stimoniaris; Dimitrios Tsiamitros; Evangelos Dialynas, "Improved Energy Storage Management and PV-Active Power Control Infrastructure and Strategies for Microgrids", IEEE Transactions on Power Systems., vol.31, no.1, pp.813 - 820, 2016

[12] Yixin Zhu; Fang Zhuo; Hongtao Shi. "Power Management Strategy Research for a Photovoltaic-Hybrid Energy Storage System". ECCE Asia Downunder (ECCE Asia), 2013 IEEE. vol., no., pp.842-848, 3-6 June 2013

[13] Xiangjun Li; Dong Hui; Xiaokang Lai. "Battery Energy Storage Station (BESS)-Based Smoothing Control of Photovoltaic (PV) and Wind Power Generation Fluctuations". IEEE Transactions on Sustainable Energy, vol.4, no.2, pp. 464-473, 2013.

[14] Richard K. Lam; Hen-Geul Yeh, "PV ramp limiting controls with adaptive smoothing filterthrough a battery energy storage system", Green Energy and Systems Conference (IGESC), 2014 IEEE, vol., no., pp.55-60, 2014

[15] James Scoltock, Tobias Geyer; Udaya K. Madawala. "A Model Predictive

Direct Current Control Strategy With Predictive References for MV Grid-Connected Converters With Filters," IEEE Transactions on Power Electronics, vol. 30, no.10, pp. 5926 - 5937, 2015

[16] Ihab S. Mohamed; Sherif A. Zaid; M. F. Abu-Elyazeed; Hany M. Elsayed, "Classical methods and model predictive control of three-phase inverter with output LC filter for UPS applications", Control, Decision and Information Technologies (CoDIT),vol, no, pp.483 - 488, 2013.

[17] Jos Rodriguez; Jorge Pontt; Cesar A. Silva; Pablo Correa; Pablo Lezana; Patricio Cortes; Ulrich Ammann, "Predictive Current Control of a Voltage Source Inverter", IEEE Transactions on Industrial Electronics, vol.54, no.1, pp. 495 - 503, 2007.

[18] J. Dionisio Barros, J. Fernando A. Silva, Elvio G. A. Jesus, "Fast-Predictive Optimal Control of NPC Multilevel Converters", vol.60, no.2, pp. 619 - 627, 2013.

[19] Katebi M R, Johnson M A, "Predictive control design for large-scale systems", Automatica, vol.33, no.3, pp. 421-425, 1997.

[20] Manoj Datta; Tomonobu Senjyu; Atsushi Yona; Toshihisa Funabashi; Chul-Hwan Kim, "A Coordinated Control Method for Leveling PV Output PowerFluctuations of PV-Diesel Hybrid Systems Connected to Isolated Power Utility ", IEEE Transactions on Energy Conversion, vol. 24, no. 1, pp.153-162, 2009.

[21] Sadegh Shajari; Reza Key Pour, "Reduction of energy storage system for smoothing hybrid wind-PV power fluctuation", Environment and Electrical Engineering (EEEIC), vol., no., pp. 115-117, 2012

[22] Y. Riffonneau, S. Bacha, F. Barruel, and S. Ploix, "Optimal power flow management for grid connected PV systems with batteries," IEEE Trans. Sustain. Energy, vol. 2, no. 3, pp. 309-320, Jul. 2011.

[23] Ding Ming, Xu Ningzhou, Bi Rui. "Modeling of BESS for smoothing renewable energy output fluctuation". Automation of Electric Power Systems, vol.35, no.2, pp. 66-72, 2011.

[24] Jiaxing Photovoltaic Industry Association http://www.jxgfhx.org/News_View.asp?AID=2836

[25] H. Chen, T. N. Cong, W. Yang, C. Tan, Y. Li, and Y. Ding, "Progress in electrical energy storage system: A critical review," Progress Nat. Sci., vol. 19, pp. 291-312, Oct. 2009.

[26] A. Etxeberria, I. Vechiu, H. Camblong, and J. M. Vinassa, "Hybrid Energy Storage Systems for renewable Energy Sources Integration in microgrids: A review," IPEC, 2010 Conference Proceedings, vol., no., pp. 532-537, 2010.

[27] Lennart Harnefors, "Analysis of Subsynchronous Torsional Interaction With Power Electronic Converters", IEEE Transactions on Power Systems, vol.22, no.1, pp.305-313, 2007.

[28] Xiongfei Wang, Member, IEEE, Frede Blaabjerg, Fellow, IEEE, and Weimin Wu, "Modeling and Analysis of Harmonic Stability in an AC Power-Electronics-Based Power System", IEEE Transactions on Power Electronics, vol.29, no.12, pp.6421-6432, 2014.

[29] Microgrid Research Programme at AAU: www.microgrids.et.aau.dk

BIOGRAPHIES



Mingyu Lei (S'14) received the B.S. degree in electrical engineering from Beijing Jiaotong University, Beijing, China in 2012. He is currently working toward the PhD degree in power electronics and power drives at Institute of Electrical Engineering, Chinese Academy of Sciences, Beijing, China. His research interests include energy management and anti-islanding protection of photovoltaic generation system, control of energy storage system, and control of converters for renewable energy generation system.



Zilong Yang received the M.S. degree from Yanshan University in Hebei Province, and the Ph.D. degree from the Institute of electrical engineering, Chinese Academy of Science, Beijing, China, in 2006 and 2010, respectively. He is presently an Associate Professor in the Renewable Energy Generation Research and Development Center, Institute of electrical engineering, Chinese Academy of Science. His research interests are in the areas of renewable energy generating techniques, energy

management system of PV microgrid.



Yibo Wang was born in 1977. He received the Ph.D. degree from the Institute of Electrical Engineering (IEE), Chinese Academy of Sciences (CAS), Beijing, China, in 2009.

He is currently a Professor with IEE, CAS. His research fields focus on renewable-energy systems and microgrids, and his main research interests include system analysis and design, grid integration, power conversion, control and protection



Honghua Xu received the B.S. and M.S. degrees from Tianjin University, Tianjin, China, in 1985 and 1988, respectively. He is currently Director and Chief Professor of Renewable Energy Department, Institute of Electrical Engineering, Chinese Academy of Science (IEE, CAS). President of Beijing Corona Sciences & Technology CO., Ltd. (Corona). Director of Photovoltaic and Wind Power Systems Quality Test Center of Chinese Academy of Sciences. Vice Director of China Renewable Energy Industry Association and China Renewable Energy Society Industry Committee.

His main research interests include Grid-connected and independent operation of wind power, solar power and hybrid power design and control technology, economic and policy research of renewable energy including wind power generating units electrical control, wind power concentration and remote monitoring, wind-solar complementary power plant etc.

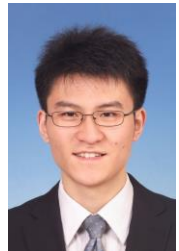

Lexuan Meng received the B.S. degree in Electrical Engineering and M.S. degree in Electrical Machine and Apparatus from Nanjing University of Aeronautics and Astronautics (NUAA), Nanjing, China, in 2009 and 2012, respectively. In 2015, he received the Ph.D. degree in Power Electronic Systems from Department of Energy Technology, Aalborg University, Denmark. He is currently a post-doctoral researcher in the same department working on flywheel energy storage and onboard electric power systems.



Juan C. Vasquez (M'12-SM'14) received the B.S. degree in electronics engineering from the Autonomous University of Manizales, Manizales, Colombia, and the Ph.D. degree in automatic control, robotics, and computer vision from the Technical University of Catalonia, Barcelona, Spain, in 2004 and 2009, respectively. He was with the Autonomous University of Manizales working as a teaching assistant and the Technical University of Catalonia as a Post-Doctoral Assistant in 2005 and 2008 respectively. In 2011, he was Assistant Professor and from 2014 he is working

as an Associate Professor at the Department of Energy Technology, Aalborg University, Denmark where he is the Vice Programme Leader of the Microgrids Research Program (see microgrids.et.aau.dk). From Feb. 2015 to April. 2015 he was a Visiting Scholar at the Center of Power Electronics Systems (CPES) at Virginia Tech and a visiting professor at Ritsumeikan University, Japan. His current research interests include operation, advanced hierarchical and cooperative control, optimization and energy management applied to distributed generation in AC/DC Microgrids, maritime microgrids, advanced metering infrastructures and the integration of Internet of Things and Cyber-Physical Systems into the SmartGrid. He has authored and co-authored more than 100 technical papers only in Microgrids in international IEEE conferences and journals.



Josep M. Guerrero (S'01-M'04-SM'08-FM'15) received the B.S. degree in telecommunications engineering, the M.S. degree in electronics engineering, and the Ph.D. degree in power electronics from the Technical University of Catalonia, Barcelona, in 1997, 2000 and 2003, respectively.

Since 2011, he has been a Full Professor with the Department of Energy Technology, Aalborg University, Denmark, where he is responsible for the Microgrid Research Program (www.microgrids.et.aau.dk). From 2012 he is a guest Professor at the Chinese Academy of Science and the Nanjing University of Aeronautics and Astronautics; from 2014 he is chair Professor in Shandong University; from 2015 he is a distinguished guest Professor in Hunan University; and from 2016 he is a visiting professor fellow at Aston University, UK, and a guest Professor at the Nanjing University of Posts and Telecommunications.

His research interests is oriented to different microgrid aspects, including power electronics, distributed energy-storage systems, hierarchical and cooperative control, energy management systems, smart metering and the internet of things for AC/DC microgrid clusters and islanded minigrids; recently specially focused on maritime microgrids for electrical ships, vessels, ferries and seaports.