



The following paper was originally published in the
Proceedings of the 4th USENIX Conference on Object-Oriented Technologies and Systems (COOTS)
Santa Fe, New Mexico, April 27-30, 1998

An Object-Oriented Framework for Distributed Computational Simulation of Aerospace Propulsion Systems

John A. Reed and Abdollah A. Afjeh
University of Toledo

For more information about USENIX Association contact:

1. Phone: 510 528-8649
2. FAX: 510 548-5738
3. Email: office@usenix.org
4. WWW URL: <http://www.usenix.org/>

An Object-Oriented Framework for Distributed Computational Simulation of Aerospace Propulsion Systems

John A. Reed and Abdollah A. Afjeh

*The University of Toledo
Toledo, Ohio*

{jreed, aafjeh}@eng.utoledo.edu

Abstract

Designing and developing new aerospace propulsion systems is time-consuming and expensive. Computational simulation is a promising means for alleviating this cost, but requires a flexible software simulation system capable of integrating advanced multidisciplinary and multifidelity analysis methods, dynamically constructing arbitrary simulation models, and distributing computationally complex tasks. To address these issues, we have developed Onyx, a Java-based object-oriented application framework for aerospace propulsion system simulation. The Onyx framework defines a common component object model which provides a consistent component interface for the construction of hierarchal object models. Because Onyx is a framework, component analysis models may be changed dynamically to adapt simulation behavior as required. A customizable visual interface provides high-level symbolic control of propulsion system construction and execution. For computationally-intensive analysis, components may be distributed across heterogeneous computing architectures and operating systems. This paper describes the design concepts and object-oriented architecture of Onyx. As a representative simulation, a set of lumped-parameter gas turbine engine components are developed and used to simulate a turbojet engine.

1 Introduction

As the aerospace propulsion industry moves into the 21st century, there is increasing pressure to reduce the time, cost and risk of jet engine development. To meet the harsh realities of today's marketplace, innovative approaches to reducing propulsion system design cycle times are needed. An opportunity exists to reduce design and development costs by replacing some of the large-scale testing currently required for product development with computational simulations. Increased use of

computational simulations promise not only to reduce the need for testing, but also to enable the rapid and relatively inexpensive evaluation of alternative designs earlier in the design process.

As a result of these forces, several government-industry cooperative research efforts have been established to develop technologies that enable the cost-effective simulation of a complete air-breathing gas turbine engine. In the United States, the Numerical Propulsion System Simulation (NPSS) project has been established between the aerospace industry, Department of Defense, and NASA. When completed, NPSS will be capable of analyzing the operation of an engine in sufficient detail to resolve the effects of multidisciplinary processes and component interactions currently only observable in large-scale tests [1, 2]. For example, more accurate predictions of engine thrust and efficiency would be possible if the "operational" geometry of a compressor rotor, stator, and casing could be determined based on an analysis of the combined aerodynamic, structural and thermal loadings [3].

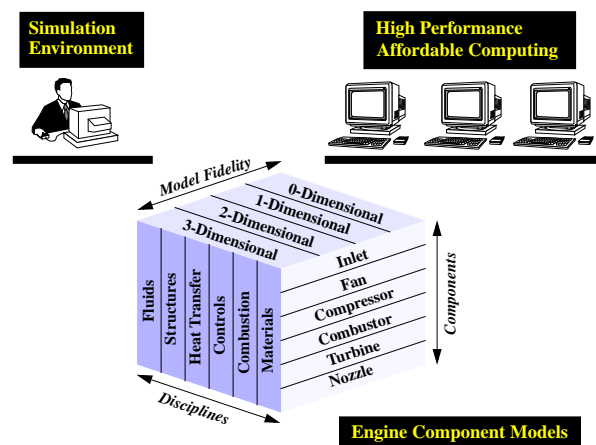

Figure 1: Topology of Computational Simulation System

The topology of such a system is shown in Figure 1. In this system, the engine component models are integrated to couple relevant disciplines, such as aerodynamics, structures, heat transfer, combustion, controls and materials. These models are then integrated at a desired level of fidelity (0-, 1-, 2-, or 3-dimensional) to form coupled subsystems for systems analysis. For required computing speed at a reasonable cost, simulation models can be distributed across a networked computing platform consisting of a variety of architectures and operating systems, including distributed heterogeneous parallel processors. A simulation environment provides a user-friendly interface between the analyst and the multitude of complex software packages and computing systems that form the simulation system.

The implementation of such a system is a major challenge. In this paper, we focus only on the design and development of a prototype *simulation environment* being developed in NPSS-related research.

1.1 Design Requirements

This section describes some of the high-level requirements which the gas turbine simulation environment must meet:

- **Component Level Modeling.** The primary requirement is for a platform which provides a general and flexible component view of the engine. Conceptually, this approach allows an engineer to develop new and different engine simulation models independent of the number of components in the engine, their type, fidelity level, or even location in the network.
- **Customization.** The environment must allow the user to customize simulation functionality by allowing components to be replaced by other components having different functionality. Such “plug-gability” is essential for keeping the architecture current. Similarly, it must be capable of supporting the integration of new simulation techniques and computing methodologies with as little effort as possible. Specifically, this intended to address the areas of *multidisciplinary coupling* and *multimodeling*.
- **Component Interoperability.** In order for the preceding design requirements to be possible, it is essential that the user be guaranteed compatibility between all components used to develop simulation models. Component interoperability is enforced through specifications of a general component model.
- **Distributed Connection and Data Transformation.** The introduction of interdisciplinary models and multimodels requires support for distributed computing as it cannot be assumed that the higher-fidelity software will run efficiently (or at all) on the same computer platform as the rest of the system. Additionally, data transferred between components having different fidelity levels and/or data formats must be transformed accordingly.
- **Portability.** The environment must be capable of operating without regard to hardware or operating system combinations. This includes the ability to leverage extensive amounts of Fortran, C and C++ legacy software.
- **User Interface.** Finally, the system must provide a user interface to reduce the efforts of developing new models and executing simulations.

1.2 Alternatives

A great number of engine simulation software packages are currently in use. Most of these are proprietary software, developed and maintained by aerospace companies. Also a number of public domain software packages, developed by NASA and Universities are also in use [4, 5]. One approach is to determine the “best” software and modify it to address the design requirements listed above. However, it has been ours and others experience that this approach often requires more effort and produces less desirable results than a completely new design [6, 7]. Generally, this is due to the following [8]:

- *Procedural design structures.* Existing (public domain) simulation software tend to utilize global data structures, such as FORTRAN common blocks, to improve simulation execution times. However, the result is a lack of data encapsulation and safety, making changes in design difficult and dangerous.
- *Discipline isolation.* Most present-day simulation models offer only simplified coupling of interactions between, for instance, aerodynamics, structures and controls. Consequently, the design of the system reflect the bias towards these disciplines. This makes it difficult to introduce new models to couple additional disciplines.
- *Assumed single processor/machine environment.* Most simulation systems were designed not to exceed perceived implementation limitations (hardware, operating systems, memory, etc.). As a result,

the software's design impedes transport to modern parallel and distributed computing platforms.

- *No Graphical Interface.* Another drawback of most presently used simulation software is the lack of graphical user interfaces (GUIs). Engine models are developed by hand through input lists. This is often a tedious process which can also result in erroneous model definition.

An alternative approach which directly addresses the first limitation, and indirectly addresses the remaining limitations is to apply *object-oriented technology* to the development of the simulation environment. Object-oriented technology is a collection of powerful design, analysis and programming methodologies for creating general-purpose adaptive models and robust, flexible software systems [9, 10].

An object-oriented (OO) approach is attractive for modeling gas turbine systems due to the natural one-to-one correspondence between objects in the application and computational domains. Consequently, multifidelity and multidisciplinary representations of engine components can be conveniently encapsulated through the use of objects. Object class morphology provides the necessary structure to accommodate a common engineering model, and to define the essential interfaces for component and disciplinary coupling. Inheritance of methods and variables in the hierarchy of classes allows extension and customization of simulation models with an economy of effort. Moreover, the same structure can be used in the design, analysis, simulation and maintenance phases of the engineering cycle.

Several prototyping efforts to develop object-oriented gas turbine simulation systems have already been completed. The first was developed by Holt and Phillips [11]. In this work an object-oriented simulator was developed in Common Lisp Object System (CLOS) with component models based on the dynamic engine software package called DIGTEM [4]. Similar prototyping efforts were carried out by Curlett and Felder [6] and Reed and Afjeh [12] in C++ and Java™ programming languages, respectively. Results from these efforts were very encouraging. In particular, the use of a graphical user interface in both the CLOS and Java simulation software greatly increased flexibility in developing engine simulation models.

1.3 Solution to Design Challenge

These prototyping efforts have illustrated the flexibility and reusability of the object-oriented approach. However, this has been achieved mainly at the application level. In order to develop a next-generation

simulation environment, we need to apply OO design concepts to the entire architecture. In recent years, two complementary concepts, *design patterns* and OO *application frameworks*, have been shown to be beneficial to developing reusable and flexible domain-specific software systems.

A framework is a reusable, “semi-complete” application that can be specialized to produce custom applications [13]. In general, the gas turbine simulation software now used are estimated to be ~80% identical, with the remaining percentage due to proprietary modifications of individual components. The great amount of commonality suggests that it might be possible to develop a generalized simulation software package based on the 80% of common features, and allowing the end user to customize the remaining 20% as desired. Frameworks can provide the necessary infrastructure to develop and manage such a generalized propulsion simulation system.

The benefits of object-oriented frameworks are due to their modularity, reusability, and extensibility. Frameworks enhance modularity by encapsulating volatile implementation details behind stable interfaces, thus localizing the impact of design and implementation changes [14]. These interfaces facilitate the structuring of complex systems into manageable software pieces — object-based *components* — which can be developed and combined dynamically to build simulation applications or composite components. Coupled with graphical environments, they permit visual manipulation for rapid assembly or modification of simulation models with minimal effort. Software component modularity also permits placement across computer platforms, making them well-suited for developing distributed simulations. Reuse of framework components can yield substantial improvements in model development and interoperability, as well as quality and performance of the computational simulation system. Frameworks enhance extensibility by providing “hooks” into the

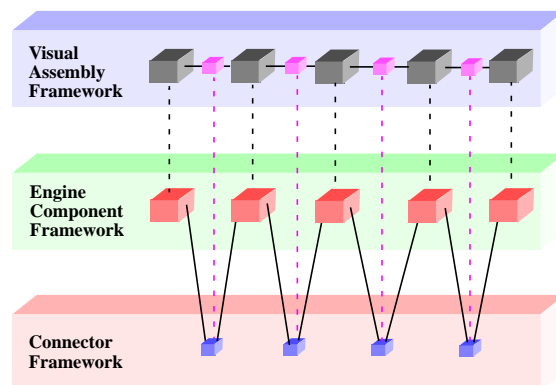

Figure 2: Onyx Framework Layers

framework. Coupled with the stable interfaces, these hooks allow the engineer to “plug” new functionality into the framework as desired. This is essential for keeping the simulation architecture current and facilitating new analytical approaches.

In the next section, we describe the design and implementation of *Onyx*, an object-oriented framework for aerospace propulsion simulation.

2 Overview of Onyx Framework

Onyx is structured as a *framework of frameworks*. Figure 2 illustrates the major structural frameworks and components which are described in this paper.

- *Engine Component Framework* - A database containing collections of domain-specific component models, such as a compressor and turbines, for use within the Visual Assembly Framework.
- *Visual Assembly Framework* - The *Onyx* graphical user interface (GUI) provides interactive control over the execution of the framework. The Visual Assembly Framework forms one part of the *Onyx* GUI and provides tools to visually assemble and manipulate a simulation model.
- *Connector Framework* - Provides a layered abstraction mechanism for distributed interconnection services between component models. Connectors also are utilized in interdisciplinary and multilevel component connections.

Onyx was developed using the Java object-oriented programming language and run-time platform [15]. Java was chosen for the *Onyx* framework because of its excellent object-oriented programming capabilities; platform-independent code execution (made possible through the use of byte-codes and a Java Virtual Machine); free availability on all major computing platforms; and, highly-integrated run-time class libraries, which serve as the foundation for *Onyx*’s graphical user interface, distributed computing architecture, as well as providing future implementation of database and native code interfacing.

To illustrate how *Onyx* can be used to develop gas turbine simulations, we will present a running example throughout this section. A transient, lumped-parameter, aero-thermodynamic turbojet engine component model, developed in our previous research, is integrated within the framework. The resulting simulation system is capable of performing steady-state and transient analyses of arbitrarily configured jet engine models.

3 Engine Component Framework

3.1 Design Challenges

A gas turbine engine is essentially an assembly of *engine components* — inlet, fan, compressors, combustor, turbine, shafts and nozzle, etc. (see Figure 3a). These components operate together to produce power (or thrust). Engine components are themselves made up of other substructures. For example, a fan component may be expressed as a collection of hub, stage, casing, splitter and flowfield substructures (see Figure 3b). These in turn may be further decomposed into more basic elements such as rotor and stator blades.

Onyx’s Engine Component Framework should allow users to simulate these structures at the various levels of abstraction as desired. For example, a user should be able to construct an engine component model from more basic models, and then use that component model to

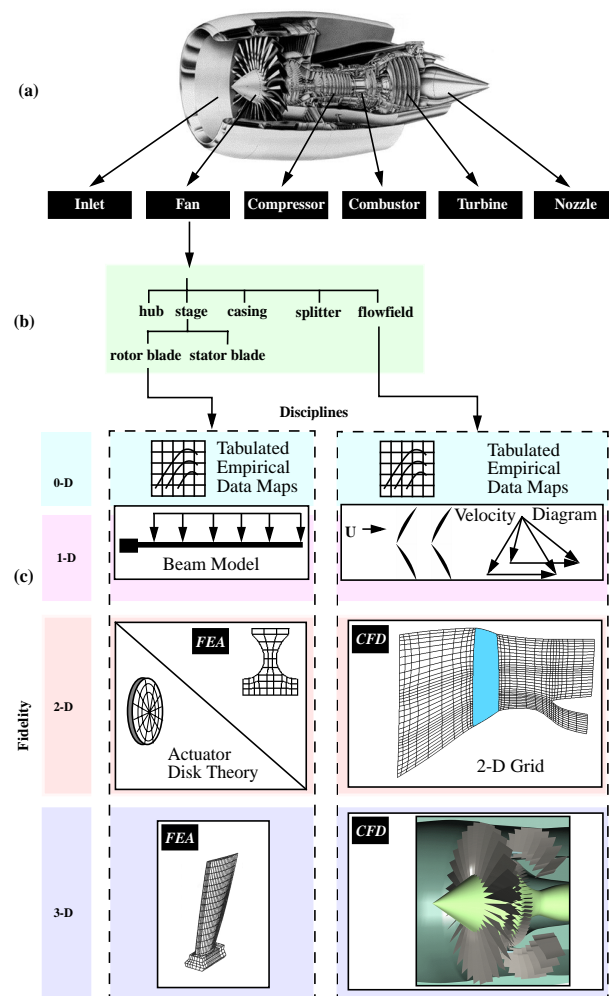

Figure 3: Engine Component Abstraction Diagram

build an engine model. Such an approach makes the process of developing gas turbine simulation models both simple and intuitive. To achieve this, we have selected an internal class structure which closely resembles the physical structure of the domain.

The component models internal structure should:

- maintain a component models physical relationship. This includes arrangement of any substructures as well as references to connected component models.
- provide control over the execution of the components simulation algorithm, which we call, its *analysis model*.

In developing the component model structure, we should not have to distinguish between single elements and assemblies of elements in our internal representation. For example, we should be able to treat a single rotor blade in the same manner as a fan component comprised of several elements, thus allowing the construction of arbitrarily complex models.

We can represent the hierarchal structure of the engine, its components, and substructures using *recursive composition*. This techniques allows us to

build increasing complex elements out of simpler ones. Returning to Figure 3b, we can combine multiple sets of rotor and stator blades to form a fan component. The fan component can then be combined with other component-level elements (compressor, combustor, etc.) to form an engine model.

3.2 Engine Component Implementation

Figure 4 illustrates the structure of the Engine Components Framework in Onyx. For simplicity, only the more important variables and methods in the classes are shown. The structure of these classes is based mainly on the *Composite* design pattern [16]. This pattern effectively captures the part-whole hierarchal structure of our component models.

EngElement is a Java interface which establishes the common behavior for all engine component classes incorporated into Onyx. It defines the basic methods needed to initialize, run and stop engine element execution, as well as methods for managing Port objects. The abstract class DefaultEngElement implements EngElement and provides default functionality for the interface methods. In most cases, users will subclass DefaultEngElement to create concrete engine component classes, such as class XyzEngElement, to implement the

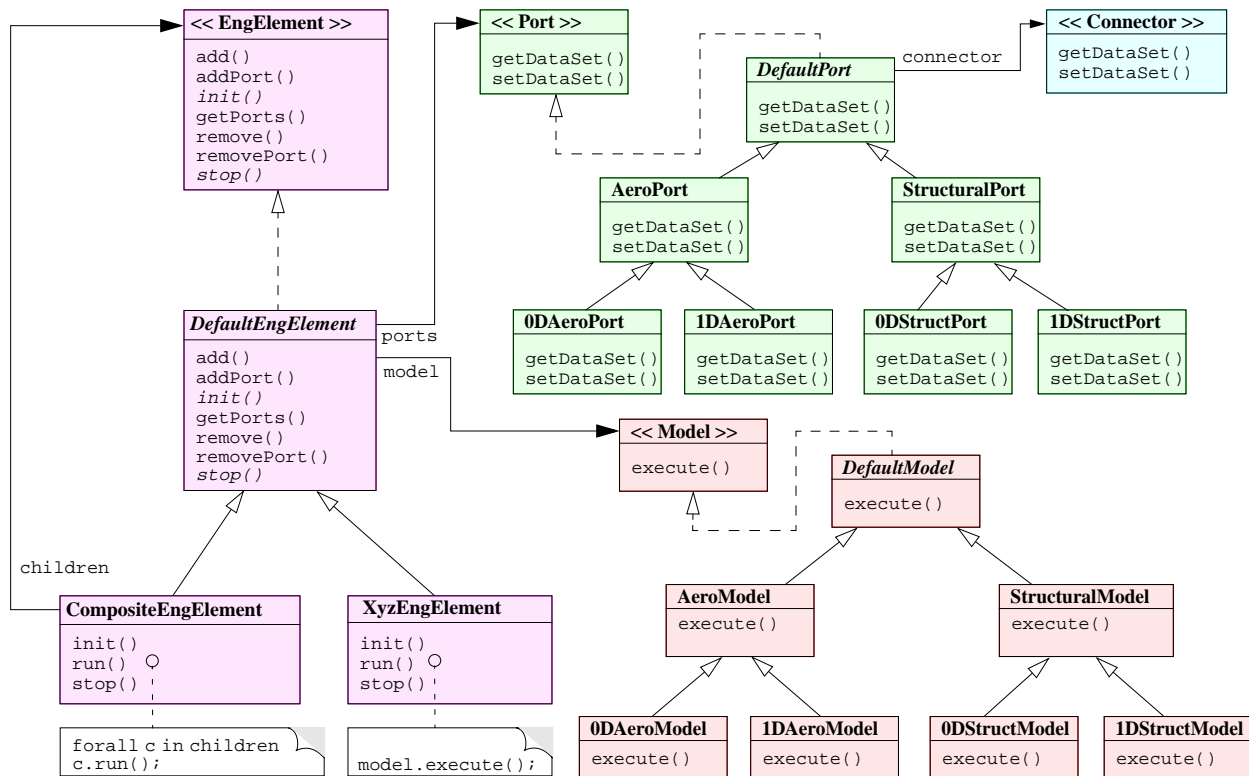

Figure 4: Structure of Engine Component Framework

required functional methods. The approach of providing a default abstract class for a Java interface is used throughout the Onyx system to give the user more flexibility when plugging in new classes. In this case, the user may select to inherit the functionality provided by `DefaultEngElement`, or to inherit from another class and implement the methods defined by the `EngElement` interface.

`CompositeEngElement` represents a composition of `EngElement` objects. Management operations for children are declared in `DefaultEngElement` to maximize component transparency. To ensure type-safety, these methods throw an exception for illegal operations, such as attempting to add or remove an `EngElement` from another `EngElement`, rather than a `CompositeEngElement`.

3.3 Analysis Model Implementation

Computational simulation involves designing a model of an actual or theoretical physical system, executing the model on digital computer, and analyzing the execution output [17]. Models are generally developed by defining a given problem domain, reducing the physical entities and phenomena in that domain to idealized form based on a desired level of abstraction, and formulating a mathematical model through the application of conservative laws.

Simulating complex systems requires the development of a hierarchy of models, or *multimodel*, which represent the system at differing levels of abstraction [18]. Selection of a particular model is based on a number of (possibly conflicting) criteria, including the level of detail needed, the objective of the simulation, the available knowledge, and given resources. For preliminary gas turbine engine design, simulation models are often used to determine the thrust, fuel consumption rates, and range of an engine. These simulations generally use relatively simple one-dimensional component models to predict performance. However, in other situations, such as *multidisciplinary analysis*, higher-order models are needed. For example, to prevent the possibility of a fan blade rubbing the cowling, an engineer might perform a coupled aerodynamic, thermal and structural analysis of the blade to determine the amount of blade bending due to the thermal and aerodynamic loading. Such an analysis would require several high-fidelity analysis models using fully three-dimensional, Navier-Stokes computational fluid dynamics (CFD) and structural Finite Element analysis (FEA) algorithms.

Ideally, one would prefer using three-dimensional analysis for an entire engine as it provides greater detail of the physical processes occurring in the system. The computational requirements for such an analysis,

however, far exceed present computer capabilities. Consequently, it is desirable for an `EngElement` to be capable of accommodating views having multiple levels of fidelity and differing disciplines. Figure 3c illustrates the concept of multiple views for a rotor blade and flowfield objects in a fan component. The rotor blade is analyzed using various mechanical-structural methods, while the flowfield is represented by various aero-fluid-dynamic methods. Based on the simulation criteria, an appropriate analysis model may be selected.

The complexity of the various analysis models suggest that it is desirable to encapsulate the analysis model, or remove it from the structure of `EngElement`. This would protect the modularity of `EngElement`, allowing new `EngElement` classes to be added without regard to the analysis model, and conversely to add new analysis models without affecting the `EngElement` class.

We apply the *Strategy* design pattern [16] to encapsulate the analysis model in an object. The `DefaultModel` class is an abstract class which implements the `Model` interface. The interface defines the methods which all `Models` must support to be integrated within Onyx. As an example, two analysis models, `ODAeroModel` and `IDAeroModel`, are shown as subclasses of `AeroModel`.

3.4 Ports

Completing the Engine Component Framework structure is the `Port` class. In physical terms, a `Port` represents a control surface through which energy and mass flow between engine components. In Onyx, `Ports` define an interface between `EngElements` through which data is passed. `Port` is an abstract class which defines the default functionality, and maintains a reference to a `Connector`. `Connectors` will be discussed in section 5. `Port` is subclassed according to the discipline (e.g. aerodynamic, structural, thermal, etc.), and these classes are then each subclassed by fidelity (0-D, 1-D, 2-D, 3-D). Which subclass of `Port` an `EngElement` instantiates is determined by the discipline-fidelity combination of the `EngElements` analysis model(s). For example, if `EngElement` has a single analysis model which is a 0-D, aerodynamic model, then an instance of `EngElement` creates two `ODAeroPort` objects to handle input and output. Because the analysis model is dynamic and may be changed at run-time, the `Port` objects also must change accordingly. Consequently, we apply the *State* design pattern [16] to dynamically create and manage the `Ports` in an `EngElement`.

3.5 Example

To illustrate the application of the Onyx framework and the feasibility of this approach, a small collection of

component object classes representing the inlet, compressor, combustor, turbine, nozzle, bleed-duct connecting-duct, and shaft, of a jet engine have been developed. An inter-component mixing volume class was also defined which is used to connect two successive components as well as define temperature and pressure at component boundaries. These concrete classes are all subclasses of the abstract `DefaultEngElement` class shown in Figure 4.

Each class implements a specific mathematical (analysis) model which describes its physical operation. In this example, the analysis models are all relatively simple differential-algebraic equations (DAE) developed from an space-averaged treatment of the conservative laws of thermo- and fluid dynamics. These are patterned after the work of Daniele et al., [4]. A complete description of the models can be found in the work of Reed [7]. The analysis model for each component is encapsulated in an appropriate subclass of `DefaultModel`, and present specific implementations of the `init()`, `run()` and `stop()` methods which initialize the component and execute its analysis model, respectively.

Appropriate Port objects are created in each component object depending on the number and type of connections required. For example, a compressor class defines two `AeroPort` objects to pass aero-thermodynamic data to adjoining components, and a `StructuralPort` to pass data to a connecting shaft object.

4 Visual Assembly Framework

4.1 Design Challenges

Aerospace engineers often use schematic drawings to represent propulsion systems and subsystems. It is then natural to represent computational simulations of such systems using this visual metaphor.

In the previous section, we developed an object-oriented component model which allows us to dynamically assemble arbitrarily complex engine system models. We now consider the development of a framework which supports visual assembly of those component models.

The main requirement of the Visual Assembly Framework is to provide visual analogs for the component model objects, and support for assembling them. This has several implications. The first is obvious: we need visual elements to represent the objects which form Onyx's engine component model. The second, less obvious requirement, is that the concept of component composition developed previously must also be supported visually. Finally, the framework must take care of managing basic graphical functions — window

management, displaying objects, moving and dragging visual elements, tracking mouse movements, etc. This reduces the programming burden for engineers using the framework.

In addition to these goals are some constraints. First, the framework should decouple the visual user interface (UI) objects from their counterparts in the component framework. Although the visual elements represent the component, we would like to allow a component's UI to be changed easily, possibly at run-time.

Second, our implementation should allow the user to override the default visual representations as much as is practically possible.

We have selected the Java platform in part because of its integrated graphical support. Java's Abstract Window Toolkit (AWT) is part of the core classes which are available in every Java Virtual Machine (JVM). The AWT provides a collection of platform-independent graphical components for building graphical applications in Java. One drawback of the AWT is that it provides only basic low-level graphical components. Another drawback is the heavyweight nature of the AWT, due to implementing graphical objects with the native windowing system.

We have opted instead to use the Swing component set to implement our graphic interface [19]. Swing is a subset of the new Java Foundation Classes (JFC), which is itself a subclass of the AWT. Therefore, our graphical interface will retain the same portability made possible with AWT. Swing however, adds more high-level graphic components, as well as the ability to select from multiple Look-and-Feel standards. However, this selection raises some immediate implementation issues.

One attractive feature of Java is its capability to develop *applets* — compiled Java programs which can be dynamically downloaded from a Web server and run locally on the client's machine using a Java-enabled browser. The ubiquity of Web browsers make implementing Onyx's visual assembly framework as an applet very attractive.

One drawback of using an applet is the relatively long time needed to implement new versions of the JVM into web browsers. Currently, the JFC is not implemented in any browser, meaning that the Swing classes used in Onyx would have to be downloaded along with the visual assembly framework each time the applet was accessed.

Another drawback associated with using an applet is its security restrictions which affect the partitioning of Onyx's structure. Generally, this limits communications between the applet to only the web server from which it was downloaded.

Because of these issues, we have designed the visual assembly framework as a Java *application*. Applications

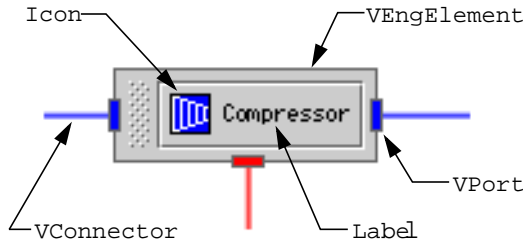

Figure 5: SchematicIcon

are similar to stand-alone programs. As the issues of browser-JVM integration and applet security issues are addressed, we will modify Onyx to permit the visual assembly framework to be distributed as an applet.

4.2 Visual Assembly Framework Design

A simulation model is constructed by creating SchematicIcon objects and connecting them to form an engine schematic. A SchematicIcon is composed of a VEngElement and one or more VPorts. VConnectors are used to “wire” the SchematicIcons together. Figure 5 illustrates these relationships.

- VEngElement is the visual analog of the EngElement class in the component framework. VEngElement is a subclass of `java.swing.JButton`, and thus contains an Icon which presents an image of the engine component; a Label which displays the name of the EngElement object instance.
- One or more VPorts are attached to the VEngElement, and represent connection points between components. VPorts are color-coded to represent the type of Port it represents.
- A VConnector is the visual analog of the Connector object. It is represented as a line drawn between two VPorts.

Each VEngElement, VPort and VConnector has a popup menu associated with it. The menu allows the user to access various functions such as moving, deleting, copying, etc. In the VEngElement, the popup menu has a special item for “customizing” the component. When selected, the customizer object is displayed.

Customizers are graphical interfaces which allow the user to change an EngElement’s attributes. Typically, these are used to modify data in the EngElement analysis model. They may also be used to control the distribution of the EngElement in a distributed simulation.

In designing the structure for our visual assembly we immediately recognize from Figure 5 that each instance

of SchematicIcon represented in the framework will likely have different Icons, display names and VPorts. One solution is to define SchematicIcon as an abstract class, and use inheritance to define subclasses which represents visually the various concrete SchematicIcon classes. Each class would then redefine the Icon image, display name, and VPort location and type. This approach however, typically leads to a very broad and shallow inheritance tree, indicating little use of inheritance.

A more useful approach would be to create an appropriate SchematicIcon using object composition. This is accomplished through the use of the parameterized *Factory* design pattern [16], in conjunction with Java’s reflection mechanism. This also allows us to address one of the design constraints listed previously: decoupling a component’s UI from its component model representation. Our solution is to apply a variation of the JavaBeans™ “Info” class concept [20].

We will illustrate this approach by creating a SchematicIcon object for an XyzEngElement object (see Figure 6). When a user creates an instance of XyzEngElement (this process will be discussed later), the Visual Assembly Framework invokes the SchematicIconFactory’s `create()` method. This method invokes the `getEngElemInfo()` method in the XyzEngElement object which returns the info class name, `XyzEngElementInfo.class`. The Factory instantiates this class using the `java.lang.reflect.Constructor.newInstance()` method. XyzEngElementInfo implements the EngElementInfo interface which defines two methods to create and return instances of PortDescriptor and EngElementDescriptor. We create and return instances

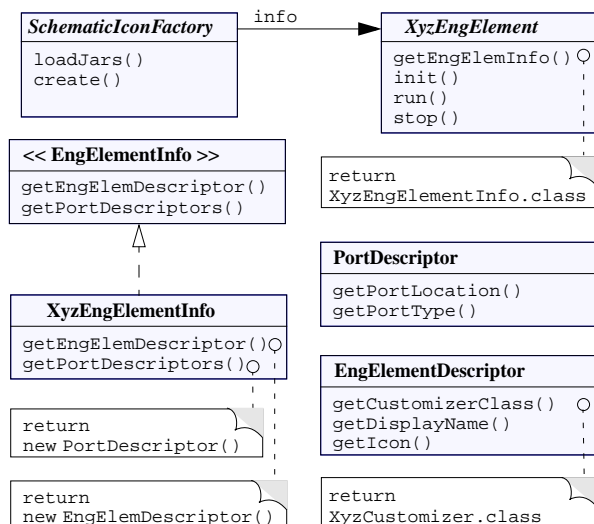

Figure 6: SchematicIcon creation process

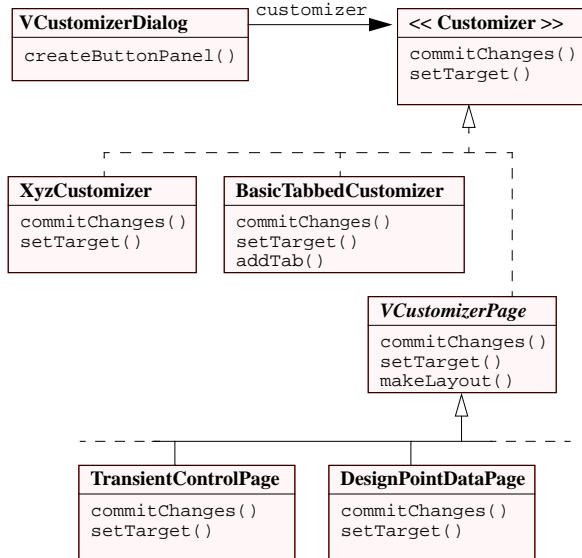

Figure 7: Customizer structure

of these classes instead of simply returning the class name, since `XyzEngElementInfo` initializes these instances by passing parameters in the constructor of each class.

`PortDescriptor` encapsulates information concerning the type, initial placement, and constraints of the `VPorts` for `XyzEngElement`. `EngElementDescriptor` defines methods which return the `Icon` image and display name `String` used in the `VEngElement` button. The method `getCustomizerClass()` returns the class name for the `XyzEngElement`'s Customizer. This class name is stored in the `VEngElement` object, and is lazily initial-

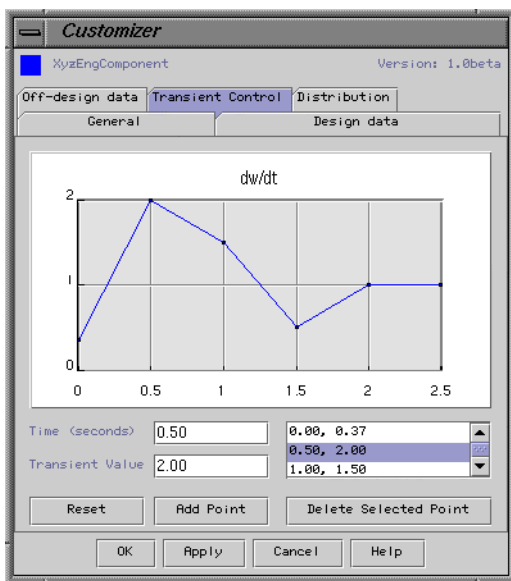

Figure 8: Onyx Customizer

ized using the `newInstance()` method.

The combination of the *Factory* pattern and Java reflection gives considerable freedom and flexibility in creating `SchematicIcons`. The composition of a `SchematicIcon` can easily be redefined by subclassing `SchematicIconFactory`. We can also use Java reflection to alter the specific classes that get instantiated in order to build the `SchematicIcon` without subclassing. Furthermore, we have effectively separated the UI implementation from component implementation. One drawback to this approach is the level of indirection introduced. However, the user sees little of this complexity as he or she is only required to define the `XyzEngElement`, `XyzEngElementInfo` and a `Customizer` class.

4.2.1 Customizers

We face another dilemma in creating customizers for each `EngElement`. `Customizer` represents a UI for defining and editing the attributes of an `EngElement`'s analysis model. Because it is strongly coupled to the data structure for each specific type of `EngElement`, we will likely end up with many different `Customizer` classes. These may or may not have any commonality, so we may not be able to take advantage of inheritance. In order to be flexible, `Onyx` must be capable of integrating each of these specific `Customizers`. Furthermore, we would like to allow users as much flexibility as is possible to customize the data UI, so we do not want to limit their options through inheritance.

Our solution is to provide an interface which defines a *plug-point* for user-defined customizers. Figure 7 shows the Customizer structure. To maximize flexibility, the Visual Assembly Framework allows the user to 1) program a new customizer, or 2) to use the `BasicTabbedCustomizer`. A user-defined customizer would inherit from `java.awt.Component` and implement the `Customizer` interface methods directly. The `commitChanges()` and `setTarget()` methods are called from the Visual Assembly framework. The constraint of inheriting from `Component` is necessary as all customizers are automatically added to an instance of `VCustomizerDialog` which expects its child to be a subclass of `Component`. `VCustomizerDialog` wraps the `Customizer` and provides a set of buttons to accept user input. The `setTarget()` method identifies the object to be updated, while the `commitChanges()` method is used to update the object when the user accepts changes to the customizer data. `XyzCustomizer` is an example of a user-defined customizer.

In the second approach, the user can subclass `VCustomizerPage`, compose it with the desired UI objects, and add it to `BasicTabbedCustomizer`. `VCustomizerPage` can provide methods to handle common issues

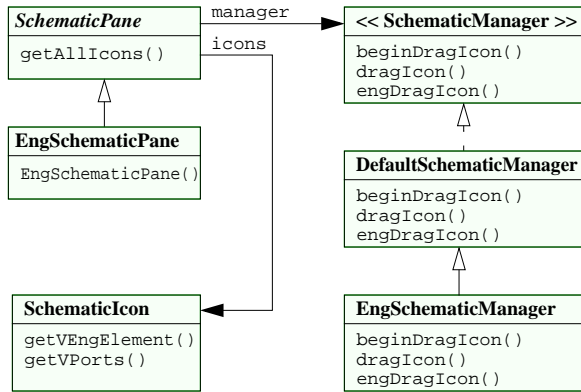

Figure 9: SchematicFrame structure

such as laying out components. Since BasicTabbedCustomizer adds instances of Customizer, it is also possible to add classes which inherit from `java.awt.Component` and implement Customizer. Figure 8 shows a picture of an instance of DefaultTabbedCustomizer, including several VCustomizerPage page objects.

The Customizer structure provides considerable flexibility. It allows the user select to compose the UI or inherit functionality and structure when developing a customizer. By adhering to an interface, users can develop different customizers and plug them in as

desired. This process is made relatively easy with a simple change to the class name returned by the `getCustomizerClass()` method in `EngElementDescriptor`. Furthermore, since the `VCustomizerDialog` accepts subclasses of `java.awt.Component`, users can use Java Integrated Development Environments (IDEs) to quickly construct customizers from AWT or Swing Java Bean GUI components.

4.2.2 Frames, Panes, Managers and SchematicIcons

Engine schematics are built by adding `SchematicIcons` to a `EngSchematicPane` which is contained in a `SchematicFrame`. `EngSchematicPane` is a subclass of `java.swing.JLayeredPane`, and maintains a listing of the `SchematicIcons` it contains, as well as their z-order (i.e., their layer). `EngSchematicPane` also keeps a reference to an `EngSchematicManager`, which provides support for selecting and moving `SchematicIcons` within the `EngSchematicPane` (see Figure 9).

The `SchematicFrame` and related classes provide required support for user interactions: dragging, moving, etc. We also support in the visual framework, the hierarchal composition concept introduced in the component framework.

In our requirements for a visual assembly framework, we indicated our desire to support visually the

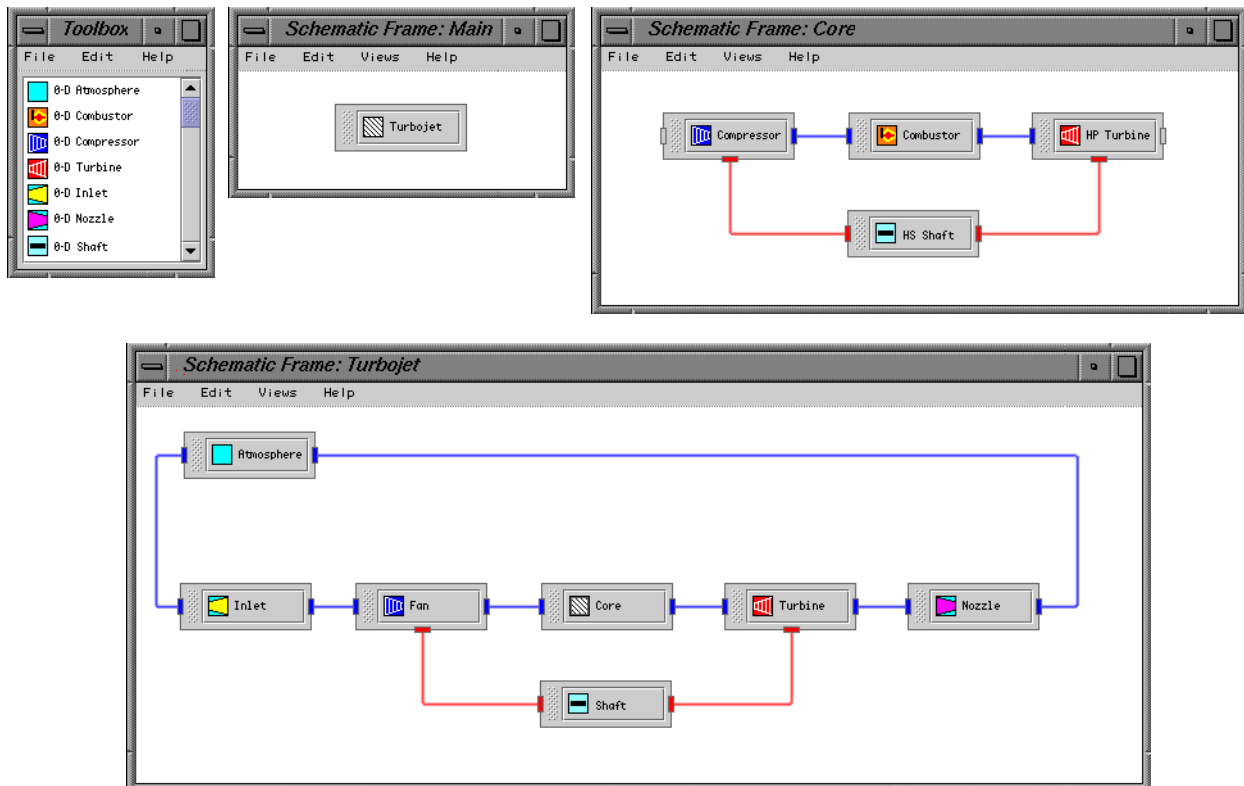

Figure 10: SchematicFrames showing visual composition

composition of EngElements in the Engine Component Framework. This is implemented using the SchematicFrame, EngSchematicPane and SchematicIcons classes. We illustrate it with an example (see Figure 10).

4.3 Example

In section 3.5, the EngElement classes representing engine components found in a turbojet engine were developed. We now demonstrate using the classes in the Visual Assembly Framework to create a simple turbojet engine. For each EngElement class, the user also defines an EngElementInfo class with appropriate descriptor information; including the icon, display name, customizer, and VPort locations. The customizer, EngElementInfo, and EngElement model and port classes for each EngElement are then collected into a Java archive (jar) file.

When the Visual Assembly Framework is started, Onyx searches the default loading directory, and loads the classes for each of the jar files. The EngElement classes are extracted and stored for instantiation by a factory object. The EngElementInfo classes are also extracted and used to obtain the display names and icons for each of the loaded EngElements. The icons and display names are listed in the Visual Assembly Toolbox which is displayed alongside the initial SchematicFrame, called Main (see Figure 10). From the Main window, the user selects the Create Composite menu command, which creates a new SchematicFrame and places a Composite SchematicIcon in the Main window. This SchematicIcon represents the top-level view of the turbojet engine, and the user names it Turbojet. This also sets the title name of the new SchematicFrame to Turbojet.

Next, the user begins to construct the turbojet engine model. From the Toolbox, the user selects an Inlet, Fan, Shaft, Turbine and Nozzle engine component to add to the Main SchematicFrame. This action creates an proper SchematicIcon for the each component and displays them in the EngSchematicPane. At the same time, Onyx instantiates their respective EngElements and adds them to an instance of CompositeEngElement in the Engine Component Framework. Our user next selects the Main SchematicFrame, and using the Create Composite command, instantiates a second SchematicFrame, which the user names Core.

From the Toolbox, the user now selects Compressor, Combustor, Shaft and Turbine components to add to the Core. SchematicIcons for these components are created and displayed in the Core EngSchematicPane. Onyx instantiates their respective EngElements and adds them to a second instance of CompositeEngElement in the Engine Component

Framework. At this time, a SchematicIcon representing the Core SchematicFrame is added to the Main EngSchematicPane.

We now have two loosely coupled composite hierarchical structures: one composed of EngElements within CompositeEngElements in the Engine Component Framework; and its corresponding visual representation composed of SchematicIcons within EngSchematicPanels. Also notice, from Figure 10, that the relationships between SchematicIcons, VPorts and VConnectors are maintained in both the Main and Core frames.

5 Connector Framework

5.1 Design Challenges

We have developed a component model for gas turbine components, as well as a compatible interface so that they can be assembled — both programmatically and visually — to form more complex systems of objects. In order for these components to interact and simulate the given system, they need to communicate. In the Onyx architecture, EngElements communicate by sending messages via a Port.

Consider a physical connection between a Inlet and Fan EngElements as shown in Figure 10. Inlet and Fan are physically and logically connected and exchange messages, such as `getDataSet()`, to retrieve data in order to update their analysis models. Normally, this process would be relatively straightforward, with the `getDataSet()` request being forwarded from the Fan via the Fan's Port to the Inlet's Port, and finally to the Inlet, where the request is carried out. In the Onyx architecture, however, this process is made more complicated by at least two situations.

5.1.1 Multifidelity Connections

The first situation occurs when two EngElements are connected which have analysis models with different discipline and/or fidelity combinations. If, for example, the Inlet component has a 1-D Fluid model and the Fan has a 2-D Fluid model, then we have a mismatch in fidelity. When the Fan processes the `getDataSet()` message, it would have some intelligence capable of transforming its 2-D data into a 1-D data set before returning it to the Inlet. Other methods are also needed to perform additional transformations (2-D to 0-D, 2-D to 3-D, etc.). Such transformation methods are clearly necessary in order for the Onyx architecture to support interdisciplinary and multifidelity modeling

Holt and Phillips [11] introduced the concept of *connector* objects to provide appropriate methods for “expanding” or “contracting” the data, and mapping

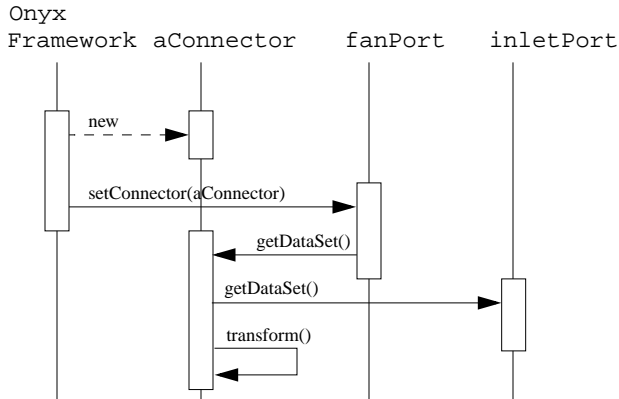

Fig. 11 - Interaction diagram

from different discipline domains. Connector objects are essentially intelligent Command objects, as described by the *Command* design pattern [16]. As with the command objects, connectors provide flexibility by decoupling the collaborating objects, making them easier to reuse. An EngElement no longer need know the discipline-fidelity of the EngElement to which it is connected. Figure 11 shows an interaction diagram using connectors.

5.1.2 Distributed Connections

The second problematic situation results from the fact that an EngElement is to be distributable to other machines. The complex and intensive computational nature of jet engine simulations require that the framework be capable of distributing computations on a network of computers. This permits access to high-performance mainframe or workstation clusters for computationally intensive tasks and, at the same time, permits user control from the local computer. Also, this feature allows on-line monitoring of computations and dynamic allocation of computational resources for optimum performance while a simulation is in progress.

Although the distribution of objects across a network is a relatively complex task, our goal is to design Onyx to perform this distribution in a manner totally consistent with non-distributed simulations. Consequently, the distribution of components across the network should be as transparent as possible to the user. No actions, other than selecting a remote machine on which to run a component, should be required to distribute the component at run-time. To illustrate the process, we return to our Inlet-Fan example.

In this scenario, the user would like to run the Fan component on a remote machine. In the Visual Assembly Framework, the user creates an Inlet and Fan. Accessing the Fan’s customizer (see Figure 8), the user

selects the “Distribution” page and selects from the list, the name of the remote machine on which to run the Fan. Now, the user (implicitly) creates a Connector by drawing a connecting line between the Inlet and Fan Ports. Notice, that with the exception of selecting the name of the remote machine, the process is exactly the same as connecting components which run on the same machine.

Placing a component object on the remote machine, however, means that the two components reside in different Java Virtual Machines. This raises a difficulty since a Connector has two variables, `port1` and `port2`, which keep references to the Port objects connected to the Connector. One of these variables would normally be referencing the Fan, but since it is in a different virtual machine, it cannot be referenced.

We can address this problem by having the Connector reference a *remote proxy*, as defined in the *Proxy* design pattern [16]. The remote proxy provides a local representation for an object in another design space.

5.2 Connector Framework Implementation

The Connector Framework structure is shown in Figure 12. The Java interface, Connector, defines our interface functionality. As with previous interfaces, we provide an abstract class, DefaultConnector, which implements the interface, provides default

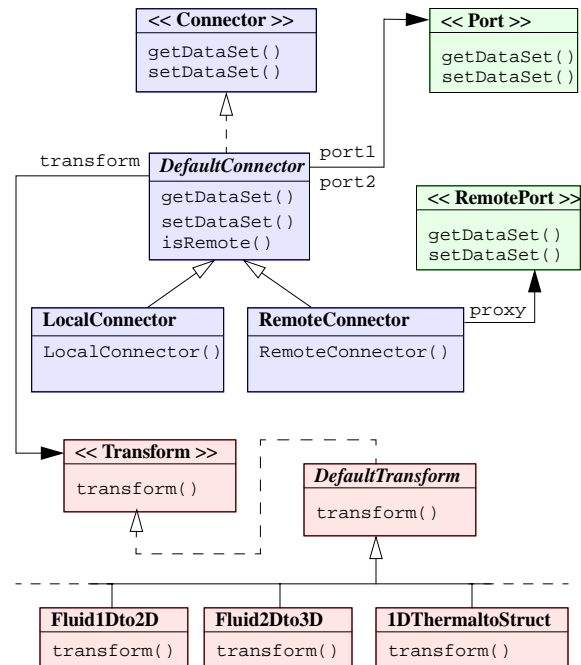

Figure 12: Structure of Connector Framework

implementation of each method, and defines the variables `port1`, `port2`, and `isRemote`. `LocalConnector` inherits all of its functionality and variables from its superclass. It represents a normal (non-remote) `Connector`. References to the `port1` and `port2` objects are passed into the constructor. `RemoteConnector`'s constructor takes an additional argument to identify the remote machine. `RemoteConnector` defines a `proxy` variable to hold the reference to the proxy object. The constructor also initializes Onyx's interconnection service to bind `proxy` to the remote object.

Onyx's distribution mechanism is currently based on the Java Remote Method Invocation (RMI), a core component of the Java platform. RMI uses client stubs and server skeletons to interface with the local and remote objects. The stub represents the remote proxy object which is referenced by the `RemoteConnector proxy` variable

Because RMI is designed to operate fully within the Java environment, it is limited to connections between machines which are running the Java Virtual Machine. By assuming the homogeneous environment of the JVM, Onyx can take advantage of the Java object model whenever possible. This provides a simple and consistent programming model. Given that most computing platforms now provide a JVM, this should not limit the use of the framework. However, we are also in the progress of integrating CORBA for providing non-Java distributed object support. This is especially important for incorporation of the multitude of legacy applications not written in Java which currently exist in the aerospace industry.

Our `Connector` now provide two sets of functionality: 1) it can transform data sets between two components of different fidelity, and 2) it establishes and maintains communications between distributed components. Although both functions are based on decoupling the connected components, we would prefer that `Connector` has a more singular functionality. This would make it more reusable in the future. To achieve this, we delegate the transformation responsibility to a separate `Transform` object. `Connector` selects an appropriate `Transform` object using a *State* pattern [16], based on the fidelity-discipline combination of the connection. The `Transform` object utilizes the *Strategy* pattern [16], to allow different transformation algorithms, such as `Fluid1Dto2D`, to be interchangeable.

The `Connector` makes connections between `EngElements` transparent. Both distributed and multifidelity connections can be made without regard to location of the component, or its fidelity. Modifying the distribution mechanism can be performed either by subclassing `DefaultConnector`, or implementing

`Connector` directly. Also, connection implementation details are fully encapsulated by the `Connector`, allowing `EngElement` and `Port` to remain unaffected by any changes to the distribution mechanism.

5.3 Example

For test purposes we have established a simple peer-to-peer distribution mechanism for the `EngElement` objects in our example model. `EngElement` objects are instantiated on the remote machine and export their interface so that their `init()`, `run()` and `stop()` methods may be called by Onyx from a local machine. In addition, a `RemotePort` interface was defined and is exported to allow connections from local (non-remote) `Port` objects. This interface allows the connectors and ports to invoke the `getDataSet()` methods to return a serialized object containing necessary engine component operating states.

Future efforts in this area will investigate the use of mobile object technology, such as `ObjectSpace's Voyager` [21], to allow the user to dynamically relocate `EngElement` objects to other platforms on the network.

6 Concluding Remarks

Designing and developing new aerospace propulsion technologies is a time-consuming and expensive process. Computational simulation is a promising means for alleviating this cost, due to the flexibility it provides for rapid and relatively inexpensive evaluation of alternative designs, and because it can be used to integrate multidisciplinary analysis earlier in the design process [22]. However, integrating advanced computational simulation analysis methods such as CFD and FEA into a computational simulation software system is a challenge. A prerequisite for the successful implementation of such a program is the development of an effective simulation framework for the representation of engine components, subcomponents and subassemblies. To promote concurrent engineering, the framework must be capable of housing multiple views of each component, including those views which may be of different fidelity or discipline [23]. In addition, the framework must address the challenges of managing this complex, computationally intensive simulation in a distributed, heterogeneous computing environment.

Object-oriented application frameworks and design patterns help to enable the design and development of aerospace simulation systems by leveraging proven software design to produce a reusable component-based architecture which can be extended and customized to meet future application requirements. The Onyx application framework described in this paper provides

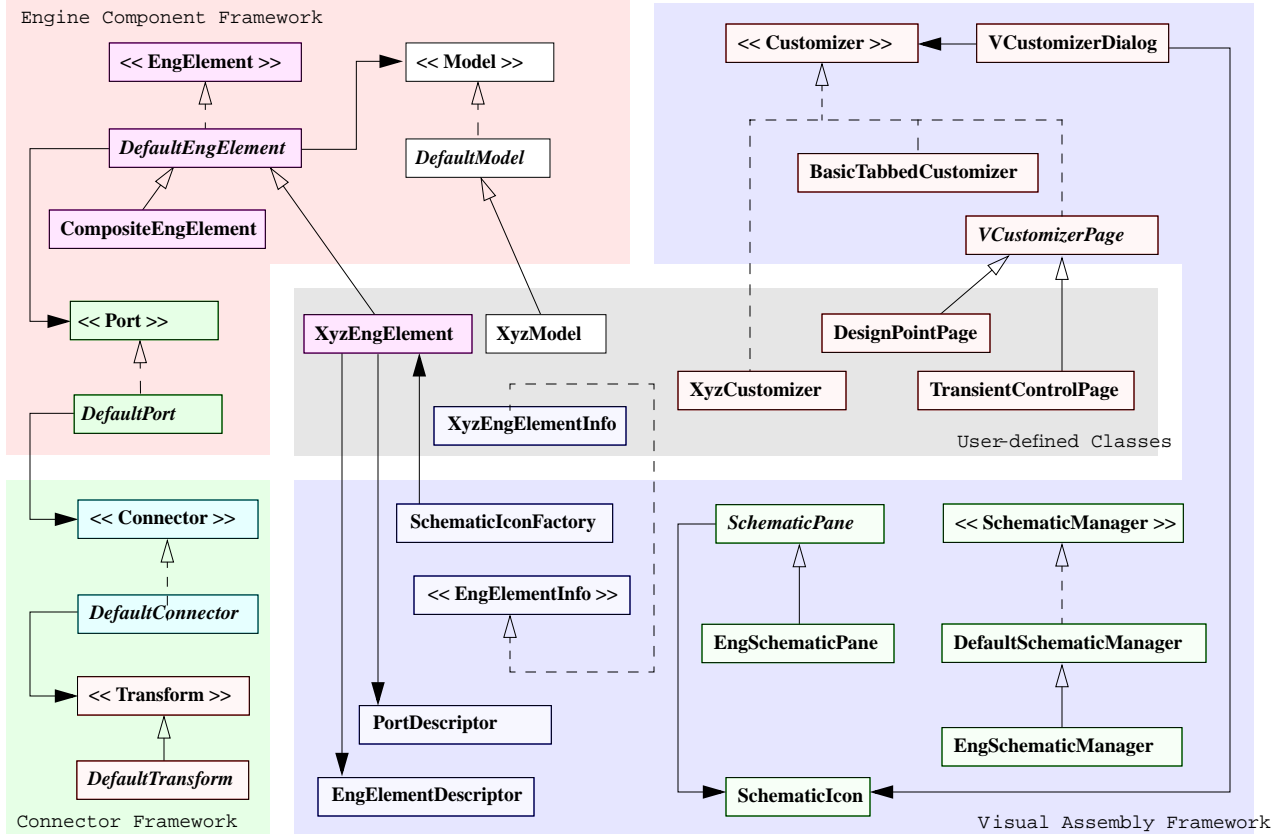

Figure 13: Onyx Aerospace Propulsion System Simulation Framework

an ensemble of framework components which, together, form an integrated framework for propulsion system simulation. Figure 13 shows how the individual framework component structures combine to form the Onyx framework.

Onyx promotes the construction of aerospace propulsion systems, such as jet gas turbine engines, in the following ways. First, it provides a common engine component object model which: encapsulates the hierarchal nature of the physical engine model, is capable of housing multimodel and multifidelity analysis models, and enforces component interoperability through a consistent interface between components. Second, it enables the construction and of engine models and customization of the simulation at a high level of abstraction through the use of visual representation in the visual assembly framework. Third, it supports both connection and transformation of data between multifidelity components running in a distributed network environment. Finally, the object-oriented design, built-in support for graphical interfaces and heterogeneous distributed processing, and automatic memory management, in Java greatly simplify and unify the design and development of Onyx.

In addition, Java's byte code and widely available Java Virtual Machine allows Onyx to be highly portable.

The use of object-oriented application framework and design pattern methods in Onyx help to decouple domain-specific simulation strategies from their implementations. This decoupling enables new simulation strategies (e.g., components, analysis models, solvers, etc.) to be integrated easily into Onyx. By applying these design strategies, Onyx allows users to dynamically alter simulation models during any phase of the simulation. The example presented in the paper serves to illustrate the flexibility, extensibility, and ease of using Onyx to develop aerospace propulsion system simulations.

Acknowledgments

The work described in this paper was made possible by funding from the NASA Lewis Research Center Computing and Interdisciplinary System Office (Grant No. NCC-3-207), and the University of Toledo. Mr. Reed is partially supported by a University of Toledo Doctoral Fellowship. We would like to thank Greg Follen at NASA Lewis for his continued support.

Special thanks also to Murthy Devarakonda for his guidance in preparing this paper. More information on Onyx is available at www-mime.eng.utoledo.edu/~jreed/.

References

- [1] Claus, R. W., Evans, A. L., Lytle, J. K., and Nichols, L. D., 1991, "Numerical Propulsion System Simulation," *Computing Systems in Engineering*, Vol. 2, pp. 357-364.
- [2] Claus, R. W., Evans, A. L., and Follen, G. J., 1992, "Multidisciplinary Propulsion Simulation using NPSS," AIAA Paper No. 92-4709
- [3] Evans, A. L., Lytle, J., Follen, G., and Lopez, I., "An Integrated Computing and Interdisciplinary Systems Approach to Aeropropulsion Simulation," ASME Paper No. 97-GT-303.
- [4] Daniele, C. J., Krosel, S. M., Szuch, J. R., and Westerkamp, E. J., 1983, "Digital Computer Program for Generating Dynamic Engine Models (DIGTEM)," NASA TM-83446.
- [5] Plencer, R., and Snyder, C., 1991, "The Navy/NASA Engine Program (NNEP89) - A User's Manual," NASA TM-105186.
- [6] Curlett, B. P. and Felder, J. L., 1995, "Object-oriented Approach for Gas Turbine Engine Simulation," NASA TM-106970.
- [7] Reed, J. A., 1993, "Development of an Interactive Graphical Aircraft Propulsion System Simulator," MS Thesis, The University of Toledo, Toledo, OH.
- [8] Drummond, C., Follen, G., and Cannon, M., 1994, "Object-Oriented Technology for Compressor Simulation," AIAA Paper No. 94-3095.
- [9] Taylor, D. A., 1990, "Object-Oriented Technology: A Manager's Guide," Addison Wesley Publishing Company, Inc., Reading, MA.
- [10] Booch, G., 1991, "Object Oriented Design with Applications," The Benjamin/Cummings Publishing Company, Inc., New York, NY.
- [11] Holt, G., and Phillips, R., 1991, "Object-Oriented Programming in NPSS Phase II Report," NASA CR-NAS3-25951.
- [12] Reed, J. A., and Afjeh, A. A., 1997, "A Java-based Interactive Graphical Gas Turbine Propulsion System Simulator," AIAA Paper No. 97-0233.
- [13] Johnson, R. and Foote, B., 1988, "Designing Reusable Classes," *Journal of Object-Oriented Programming*, Vol. 1, pp. 22-35.
- [14] Schmidt, D. C., 1997, "Applying Design Patterns and Frameworks to Develop Object-Oriented Communications Software," *Handbook of Programming Languages, Volume I*, P. Salus, ed., MacMillian Computer Publishing.
- [15] Arnold, K. and Gosling, J., 1996, "The Java Programming Language," Addison Wesley Publishing Company, Inc., Reading, MA.
- [16] Gamma, E., Helm, R., Johnson, R., and Vlissides, J., 1995, "Design Patterns: Elements of Reusable Object-Oriented Software," Addison Wesley Publishing Company, Inc., Reading, MA.
- [17] Fishwick, P. A., 1997, "Computer Simulation: Growth Through Extension," *TRANSACTIONS of The SCS*, Vol. 14, pp. 13-23.
- [18] Fishwick P. A. and Zeigler, B. P., 1992, "A Multimodel Methodology for Qualitative Model Engineering," *ACM Transactions on Modeling and Computer Simulation*, Vol. 12, pp. 52-81.
- [19] Swing, 1997, "The Swing Connection," Available from <http://java.sun.com/products/jfc/swingdoc-current/index.html>.
- [20] Englander, R., 1997, "Developing Java Beans," O'Reilly & Associates, Inc., Sebastopol, CA.
- [21] Voyager, 1998, "ObjectSpace Voyager Core Package Technical Overview," Available from <http://www.objectspace.com/>.
- [22] Jameson, A., 1997, "Re-Engineering the Design Process through Computation," AIAA Paper No. 97-0641.
- [23] Irani, R. K., Graichen, C. M., Finnigan, P. M., and Sagendorph, F., 1994, "Object-based Representation for Multidisciplinary Analysis," AIAA Paper No. 94-3093.